

A COURSE IN
**ELECTRICAL AND ELECTRONIC MEASUREMENTS
AND
INSTRUMENTATION**

By

A. K. SAWHNEY

M.Sc. (Engg.)

Professor of Electrical Engineering

Thapar Engineering College,

PATIALA

DHANPAT RAI & SONS

EDUCATIONAL AND TECHNICAL PUBLISHERS

1682, Nai Sarak, Delhi-110006

Phone : 265367

©All rights reserved by the author. No parts of this publication may be reproduced, stored in retrieval system, or transmitted, in any form or by any means, electronic, mechanical, photocopying, recording, or otherwise, without the prior written permission of the author and the publisher.

By the Same Author

1. A Course in Electrical Machine Design.
2. A Course in Mechanical Measurements and Instrumentation.

First Edition : 1973
Second Edition : 1976
Reprint : 1978
Reprint : 1979
Reprint : 1980
Third Edition : 1981 (*Modified and Enlarged*)
Reprint : 1982
Fourth Edition : 1983
Reprinted : 1984
Reprint : 1985

Compiled by : Smt. Chander Sawhney

Price. Rs. 60/-

Published by : J.C. Kapur, for Dhanpat Rai & Sons, Delhi-110006 (H.O. Jullundur).

Composed by : Karan Printing Service, Subhash Park, Shahdara, Delhi-110032.

Printed at : D.R. Printing Service, Panchsheel Garden, Shahdara, Delhi-110032/

Preface to the Fourth Edition

The author is pleased to bring out the Fourth Edition of the book and is thankful to both teachers and students for their affectionate and warm reception to the third edition of the book which has been sold out in a period of less than one year. The present edition retains essentially the same subjectmatter as the third edition. However, the typographical and other errors, which had crept in earlier edition, have been corrected.

The book is intended as a standard text for students studying for their first degree in Electrical, Electronics and Instrumentation Engineering at Indian Universities and abroad, and also for those appearing for A.M.I.E. section B and other professional examinations. The book is equally useful for postgraduate students as well as practising engineers involved in the field of Measurements and Instrumentation.

There have been significant changes in curriculum of almost all the universities in recent years. Electrical and Electronic Instrumentation is now offered as separate paper in many universities. This has been necessitated on account of latest technological advances which put greater emphasis and reliance on Electronic Instrumentation.

The contents of the book have been drastically modified, re-arranged and updated to acquaint the reader of modern trends in the field of Measurements and Instrumentation.

The book has been divided into two parts. Part I deals with Measurements and Measuring Instruments and Part II takes care of the Instrumentation. There is an extensive coverage of Electrical and Electronic Instrumentation in this edition of the book as compared with the earlier ones. The coverage of Instrumentation portion is about 500 pages out of a total of nearly 1200 pages. The subject of Instrumentation has been developed in logical steps. Separate chapters are devoted to topics like Generalized Measurement Systems, Transducers, Signal Conditioning, Data Transmission and Telemetry, Display Devices and Recorders, Measurement of Non-electrical Quantities and Data Acquisition Systems. Also there are additional chapters on static and dynamic characteristics of Measurement Systems. There is an increased emphasis on digital instruments and instrumentation which is constant with the present trends.

There are three Appendices in the book. Appendix A deals with Number Systems, Appendix B with Logic gates and Appendix C with conversions from various systems of units to S.I. The significant additions to the measurements portion are Transformer ratio bridges (which are fast replacing the conventional four arm a.c. bridges), spectrum analyzer, vector impedance meter, vector meter, digital maximum demand indicator and Hall effect multiplier to name a few.

The book in fact covers a very wide spectrum of the field of Electrical and Electronic Measurements and Instrumentation and is a complete reference in itself.

Another outstanding feature of the book is the inclusion of over 400 solved problems which in addition to linking the theory with actual applications gives an insight of the industrial practice. Also about 300 unsolved problems (with answers) have been included to give the students practice in solving problems.

The author considers the inclusion of problems on Instrumentation (both solved and unsolved) as a speciality of this book. This is a pioneering effort which is the outcome of author's experience of teaching the subject for almost two decades.

The book though voluminous, covers two papers, i.e., first on Electrical and Electronic Measurements and Instruments and second on Electrical and Electronic Instrumentation and thus fully justifies its volume. SI units have been uniformly used in the book throughout.

The author will feel highly obliged to all the readers for their constructive suggestions and healthy criticism of the book which will go a long way in the improvement of the text.

The author is thankful to his wife, Chander, for rendering assistance in the compilation and editing of the work.

The author is grateful to his brothers, Ravish and Ajay, for their constant help during the preparation of the text.

To author's parents who have been a source of encouragement and guidance.

PATIALA 26-9-1982

A.K. SAWHNEY

*DEDICATED
TO
Anuradha and Puneet*

Cha

Chap

Chap

Chapt

Contents

PART I

ELECTRICAL AND ELECTRONIC MEASUREMENTS AND MEASURING INSTRUMENTS

Chapter 1—Measurements and Measuring Systems

1-8

Measurements. Significance of Measurements. Methods of Measurement. Direct Methods. Indirect Methods. Instruments. Mechanical, Electrical and Electronic Instruments. Mechanical Instruments. Electrical Instruments. Electronic Instruments. Classification of Instruments. Analog and Digital. Modes of Operation. Functions of Instruments and Measurement Systems. Applications of Measurement Systems. Elements of a Generalized Measurement System.

Chapter 2—Characteristics of Instruments and Measurement Systems

9-34

Measurement System Performance. Static Calibration. Static Characteristics. Errors in Measurements. True Value. Static Error. Static Correction. Scale Range and Scale Span. Error Calibration Curve. Reproducibility and Drift. Repeatability. Noise. Accuracy and Precision. Indications of Precision. Significant Figures. Range of Doubt or Possible Errors and Doubtful Figures. Static Sensitivity. Instrument Efficiency, Index Scale and Index Number. Linearity. Hysteresis. Threshold, Dead Time. Dead Zone. Resolution or Discrimination. Loading Effects. Loading Effects due to Shunt connected Instruments. Loading Effects due to Series connected Instruments. Impedance Matching and Maximum Power Transfer. Dynamic Response. Measuring Lag. Standard Signals. Overshoot. Unsolved Problems.

Chapter 3—Errors in Measurements and their Statistical Analysis

35-64

Limiting Errors (Guarantee Errors). Relative (Fractional) Limiting Errors. Combination of Quantities with Limiting Errors. Known Errors. Types of Errors. Gross Errors. Systematic Errors. Instrumental Errors. Environmental Errors. Observational Errors. Random (Residual) Errors. Central Value. Statistical Treatment of Data. Histogram. Arithmetic Mean. Measure of Dispersion from the Mean. Range. Deviation. Average Deviation. Standard Deviation (S.D.), Variance. Normal or Gaussian Curve of Errors. Precision Index. Probable Error. Average Deviation for the Normal Curve. Standard Deviation for the Normal Curve. Probable Error of a Finite Number of Readings. Standard Deviation of Mean. Standard Deviation of Standard Deviation. Specifying ODDS. Specifying Measurement Data. Variance and Standard Deviations of Combination of Components. Probable Error of Combination of Components. Uncertainty Analysis and Treatment of Single Sample Data: Propagation of Uncertainties. Unsolved Problems.

Chapter 4—Units, Systems, Dimensions and Standards

65-101

Introduction. Unit. Absolute Units. Fundamental and Derived Units. Dimensions. Dimensions of Mechanical Quantities. Historical Background of System of Units. CGS System of Units: Electromagnetic Units (e.m.

(ii)

units). Electrostatic Units (e.s. units). Practical Units. Dimensional Equations. Dimensions in Electrostatic System. Dimensions in Electromagnetic System. Relationship between Electrostatic and Electromagnetic Systems of Units. M.K.S. System (Giorgi System). Rationalised M.K.S.A. System. SI Units. Base Units of SI. Supplementary Units. Multiplying Prefixes of Units. Determination of Absolute Units. Absolute Measurement of Current: Rayleigh's Current Balance. Absolute Measurement of Resistance: Lorenz Method. Standards and their Classification: International Standards. Primary Standards. Secondary Standards. Working Standards. Standards for Mass and Length. Atomic Frequency and Time Standards. Temperature Standards. Luminous Intensity Standards. Electrical Standards. Emf Standards: Primary Standard of Emf. Secondary Standard of Emf. Laboratory Standards of Emf. Higher Voltage Zener Sources and Temperature Effects. Primary Standards of Resistance. Current Standards. Inductance Standards. Capacitance Standards. Unsolved Problems.

Chapter 5—Circuit Components (Resistors, Inductors and Capacitors) and their Residues 102—122

Residues. Resistors. Resistance Materials. Spools (Formers) for Coils. Resistance Wires. Ageing. Annealing. Resistance Standards. Resistance Standards for D.C. Low Resistance Standards. Standard Resistances for A.C. Circuits. Frequency Errors of Resistors. Methods of Reducing Residual Inductance. Resistance Boxes. Thin Film Resistors. Composition Resistors. Shielded Resistors.

INDUCTORS

Standards of Inductance. Formers for Inductance Coils. Coils of Inductance Coils. Standards of Mutual Inductance. Standards of Self-Inductance. Variable Inductances. Inductors for High Frequency Work. Inductors for Low Frequency Work. Frequency Errors in Inductors.

CAPACITORS

Loss Angle and Power Factor. Distributed Capacitance. Capacitance Standards. Vacuum and Gas-filled Capacitors. Solid Dielectric Capacitors. Variable Capacitors. Decade Capacitance Boxes. Frequency Errors in Capacitors. Unsolved Problems.

Chapter 6—Analog (pointer) Instruments 123—139

Analog Instruments. Classification of Analog Instruments. Principles of Operation.

ELECTROMECHANICAL INDICATING INSTRUMENTS

Operating Forces. Constructional Details. Types of Supports. Balancing. Torque/Weight Ratio. Control Systems. Damping Systems. Eddy Current Damping. Torque of Metal Former. Damping Torque of a Metal Disc. Permanent Magnets. Pointers and Scales. Recording Instruments. Integrating Instruments. Unsolved Problems.

Chapter 7—Galvanometers 140—191

Introduction. D'Arsonval Galvanometer. Construction of d'Arsonval Galvanometer. Torque Equation. Dynamic Behaviour of Galvanometers. Equation of Motion. Underdamped Motion of a Galvanometer. Undamped Motion of a Galvanometer. Critically Damped Motion of a Galvanometer. Operational Constants. Relative Damping. Logarithmic Decrement. Over-

shoot. Overdamped Motion of Galvanometer. Non-dimensional Curves of a Galvanometer Motion. Damping. Sensitivity. Galvanometer Types. Galvanometer Shunts. Ayrton Universal Shunt. Ballistic Galvanometer. Calibration of a Ballistic Galvanometer. Flux Meter. Use of Shunt with Fluxmeter. Vibration Galvanometers. Duddell's Oscillograph. Unsolved Problems.

Chapter 8—Analog Ammeters, Voltmeters and Ohmmeters

192—268

Introduction. Power Loss. Types of Instruments. Errors in Ammeters and Voltmeters. Permanent Magnet Moving Coil Instruments (PMMC) Construction. Torque Equation. Range. Ammeter Shunts. Arrangement for Temperature Effect Correction. Multi-range Ammeters Voltmeter Multipliers. Effect of Temperature Changes. Multirange d.c. Voltmeters. Sensitivity. Voltmeter Sensitivity and Loading Effects. Errors. Advantages and Disadvantages.

Ohmmeters. Introduction. Series-type Ohmmeter. Shunt type Ohmmeters. Multimeter or Volt-Ohm-Milli-ammeter (V.O.M.). Ratiometer. Ratiometer Ohmmeters. Megger. Ducter Ohmmeter.

Moving Iron Instruments General Torque Equation Classification of Moving Iron Instruments. Attraction Type Repulsion Type. Reason for Use on both A.C. and D.C. Shape of Scale Long Scale Instruments. Shunt for Moving Iron Instruments. Multipliers for Moving Iron Instruments. Comparison between Attraction and Repulsion Types of Instruments. Errors. Advantages and Disadvantages. Electro-dynamometer (Electrodynamometer) Type Instruments. Operating Principle Construction. Torque Equation. Electro-dynamometer Ammeters. Electro-dynamometer Voltmeters Errors. Use on D.C. and A.C. Shape of Scale. Advantages and Disadvantages. Ranges Use of Electro-dynamometer Type Instruments at High Frequencies. Ferrodynamometer Instruments. Construction Operation. Advantages and Disadvantages Electrothermic Instruments. Classification Hot Wire Instruments. Thermoelectric Instruments. Thermal Emf. Principle of Operation. Heater Element. Thermo-element. Shape of Scale Connections. Advantages and Disadvantages. Ranges Electrostatic Instruments. Force and Torque Equations. Quadrant Electrometer Kelvin Multicellular Voltmeter. Attraction Type Portable Instruments. Attracted Disc Type-Kelvin Absolute Electrometer. Everett Edgcombe Voltmeter. Use on both A.C. and D.C. Shape of Scale. General Considerations Extension of Range of Electrostatic Voltmeters. Errors Advantages and Disadvantages. Induction Type Instruments. Principle of Operation. Types of Instruments. Ferraris Type. Shaded Pole Type. Shape of Scale. Advantages and Disadvantages. Rectifier Instruments. Rectifier Elements. Rectifier Characteristics. Rectifier Voltmeters. Full Wave Rectifier Circuit. Factors Influencing the Performance. Half Wave Rectifier Circuits. Multi-meters. Simpson's Multimeter. Rectifier Ammeters. Advantages of Rectifier Instruments. Unsolved Problems.

Chapter 9—Instrument Transformers

289—332

Introduction. Use of Instrument Transformers. Ratios. Burden.

CURRENT TRANSFORMERS

Theory. Errors. Characteristics of Current Transformers Causes of Errors. Reduction of Errors. Construction of Current Transformers. Clamp on Ammeters. Effect of Secondary Open Circuit. Permanent Magnetization and

its Demagnetization. Current Transformers for High Frequencies. Potential Transformers. Difference between C.T. and P.T. Theory. Errors. Reduction of Errors. Construction of Potential Transformers. High Voltage Potential Transformers. Capacitive Potential Transformers Characteristics of Potential Transformers. Testing of Instrument Transformers. Current Transformer Testing. Potential Transformer Testing. Unsolved Problems.

Chapter 10—Measurement of Power and Wattmeters

333—370

Power in D.C. Circuits. Power in A.C. circuits. Electrodynamometer Wattmeters. Construction. Theory. Shape of Scale. Wattmeter Errors. Torsion-head Electrodynamometer Wattmeters. Ferrodynamometer Wattmeters. Cambridge Reflecting Wattmeter. Low Power Factor Wattmeters (Electrodynamometer type). Thermocouple Wattmeter (Thermal Watt Converter) Electrostatic Wattmeters. Induction Type Wattmeters. Lipman Type Induction Wattmeter. Hall Effect Multiplier. Measurement of Power Using Instrument Transformers. Power in Poly-Phase Systems. Measurement of Power in Three Phase Circuits. Three Phase Wattmeters. Measurement of Reactive Power. Summation Metering. Unsolved Problems.

Chapter 11—Measurement of Energy and Industrial Metering

371—403

General. Motor Meters. Braking. Friction. Energy Meters for A.C. Circuits. Single Phase Induction Type Watt-hour Meters. Construction. Theory and Operation. Lag Adjustment Devices. Light Load or Friction Compensation. Creep. Over-Load Compensation. Voltage Compensation. Temperature Compensation. Errors. Adjustments. Polyphase Energy Meters. Two Element Energy Meter. Industrial Metering and Tariffs. Maximum Demand Indicators. Measurement of VAh and VARh. VARh Metering. Measurement of VAh.

ENERGY METER TESTING

Types of Tests. Phantom Loading. Testing Methods. Meter Testing Circuits. Unsolved Problems.

Chapter 12—Measurement of Phase and Frequency

404—423

POWER FACTOR METERS

Introduction. Single Phase Electrodynamometer Power Factor Meter. Three Phase Electrodynamometer Power Factor Meter—Construction. Moving Iron Power Factor Meters. Rotating Field Power Factor Meter. Alternating Field Power Factor Meter (Nalder Lipman Type). Advantages and Disadvantages of Moving Iron P.F. Meters.

FREQUENCY METERS

Types of Frequency Meters. Mechanical Resonance Type Frequency Meter (Vibrating Reed Type). Electrical Resonance Type Frequency Meters. Weston Frequency Meter. Ratiometer Type Frequency Meter. Saturable Core Frequency Meter.

SYNCHROSCOPES

Synchronizing. Electro-dynamometer (Weston) Type Synchroscope. Moving Iron Synchrosopes. Phase Sequence Indicators.

Classification of Resistances.

MEASUREMENT OF MEDIUM RESISTANCES

Methods of Measurement of Medium Resistances. Ammeter Voltmeter Method. Substitution Method. Wheatstone Bridge. Sensitivity of Wheatstone Bridge. Galvanometer Current. Precision Measurement of Medium Resistances with Wheatstone Bridge. Carey-Foster Slide-wire Bridge. Kelvin Varley Slide. Limitations of Wheatstone Bridge.

MEASUREMENT OF LOW RESISTANCES

Introduction. Construction of Low Resistances. Methods for Measurement of Low Resistance. Ammeter Voltmeter Method. Kelvin Double Bridge. Kelvin Bridge Ohmmeter. Unbalanced Kelvin Bridge.

MEASUREMENT OF HIGH RESISTANCES

Introduction. Difficulties in Measurement of High Resistances. Use of Guard Circuit. Methods for Measurement of High Resistance. Direct Deflection Method. Loss of Charge Method. Megohm Bridge Method. Measurement of Insulation Resistance with Power On. Unsolved Problems.

Chapter 14—Potentiometers

455—480

D.C. POTENTIOMETERS

Introduction. Basic Potentiometer Circuit. Laboratory Type (Crompton's) Potentiometer. Multiple-Range Potentiometer. Constructional Details of Potentiometers. Precision Type Potentiometers. Vernier Potentiometer. Standard Cell Dial. True Zero. Brooks Deflectional Potentiometer. Volt-Ratio Box. Application of D.C. Potentiometers. Protection of Standard Cell and Galvanometer. Self-Balancing Potentiometers.

A.C. POTENTIOMETERS

Introduction. Standardizing of A.C. Potentiometers and Use of Transfer Instruments. Types of A.C. Potentiometers. Drysdale Polar Potentiometer. Gall-Tinsley (co-ordinate type) A.C. Potentiometer. Quadrature Adjustments of Currents. Campbell-Larsen Potentiometer. Applications of A.C. Potentiometers. Unsolved Problems.

Chapter 15—Power System Measurements

481—495

MEASUREMENT OF EARTH RESISTANCE

Necessity of Earth Electrode. Necessity of Measurement of Resistance of Earth Electrode. Factors Affecting Earth Resistance. Methods of Measuring Earth Resistance.

LOCALIZATION OF CABLE FAULTS

Types of Faults. Methods Used for Localizing Faults. Methods Used for Localizing Ground and short Circuit Faults. Murray Loop Test. Varley Loop Test. Location of Open Circuit Faults in Cables.

SYMMETRICAL COMPONENTS AND THEIR MEASUREMENT

Introduction to Symmetrical Components. Calculation of Symmetrical Components. Measurement of symmetrical Components. Measurement of

Positive Sequence Component of Current. Measurement of Negative Sequence Component of Current. Measurement of Zero Sequence Component of Current. Measurement of Positive-Sequence Component of Voltage. Measurement of Negative Sequence Components of Voltage. Measurement of Zero Sequence Component of Voltage. Vector Meter. Unsolved Problems.

Chapter 16—A.C. Bridges

496—539

Introduction. Sources and Detectors. General Equation for Bridge Balance. General form of an A.C. Bridge.

MEASUREMENT OF SELF INDUCTANCE

Maxwell's Inductance Bridge. Maxwell's Inductance--Capacitance Bridge. Hay's Bridge. Anderson's Bridge. Owen's Bridge. Measurements of Incremental Inductance.

MEASUREMENT OF CAPACITANCE

De Santy's Bridge. Schering Bridge. High Voltage Schering Bridge. Measurement of Relative Permittivity with Schering Bridge.

MEASUREMENT OF MUTUAL INDUCTANCE

Uses of Mutual Inductance in Bridge Circuits. Mutual Inductance Measured as Self-Inductance. Heaviside Mutual Inductance Bridge. Campbell's Modification of Heaviside Bridge. Heaviside Campbell Equal Ratio Bridge. Carey Foster Bridge; Heydweiller Bridge. Campbell's Bridge.

MEASUREMENT OF FREQUENCY

Wien's Bridge. Universal Impedance Bridge. Sources of Errors in Bridge Circuits. Precautions and Techniques used for Reducing Errors. Stray Electromagnetic and Electrostatic Couplings. Shielding of Bridge Elements. Wagner Earthing Device. Screened-and-balanced Transformers. Difference and Substitution Methods. Transformer Ratio Bridges Applications and Features of Ratio Transformers. Measurement of Resistance. Measurement of Capacitance. Measurement of Phase Angle. Transformer Double Ratio Bridges. Measurement of Inductance. Measurements of Components in 'SITU'. Unsolved Problems

Chapter 17—High Voltage Measurements and Testing

540—569

Types of Tests. Testing Apparatus. High Voltage Transformers. Voltage Control. Voltage Control by Variation of Alternator Field Current. Voltage Control by Resistance Potential Divider. Reactance Voltage Control. Voltage Control by Tapped Transformer. Voltage Control by Variac. Voltage Control by Induction Regulators. Control Gear and Protective Devices. Equipment for Voltage Measurement. Measurement of R.M.S. Values of Voltage. Measurement of Peak Values of Voltages. Measurement of D.C. Voltages. Measurement of Instantaneous Voltage. Low Frequency H.V. Tests. High Voltage D.C. Testing. Cockcroft Walton Circuit. High Voltage D.C. Testing of Cables. Equivalence of D.C. and A.C. Test Voltages. Localization of Faults in High Voltage Cables. High Frequency Tests. Surge (Impulse) Testing. Basic Impulse Generator Circuit. Single Stage Impulse Generators. Multi-stage Impulse Generator. Impulse Testing of Transformers. Testing of Insulating Materials. High Voltage Testing of Cables. High Voltage Tests on Porcelain Insulators. Testing of Electric Strength of Insulating Oils.

Introduction. Types of Tests.

BALLISTIC TESTS

Measurement of Flux Density. Measurement of Value of Magnetising Force (H). Magnetic Potentiometer. Testing of Ring Specimens. Determination of B-H Curve. Determination of Hysteresis Loop. Testing of Bar Specimens. Permeameters. Hopkinson Permeameter (Bar and Yoke method). Ewing Double Bar Permeameter. Illiovi Permeameter. Burrows Permeameter. Fahy's Simplex Permeameter. The National Physical Laboratory (England) form of Permeameter. Measurement of Leakage Factor with Flux Meter

ALTERNATING CURRENT MAGNETIC TESTING

Iron Loss Curves. Separation of Iron Losses. Methods of Iron Loss Measurement. Wattmeter Method. Bridge Methods. A.C. Potentiometer Method. Oscillographic Method. Methods of Measurements of Air Gap Flux. Testing of Permanent Magnets. Magnetostriction. Methods used in Modern Instrumentation Systems. Unsolved Problems.

Chapter 19—Illumination

610—638

Physics of Light. Light. Electromagnetic Spectrum. International Luminosity Curve. Photon. Energy and Power. Intensity. Effect of Temperature on Radiation. Full Radiator or Black Body. Primary Standard. Calibration of Standard Lamps with Primary Standard. Secondary Standards and Substandards. Laboratory Standards. Terms, Definitions and Symbols. Laws of Illuminance (Illumination). Visual Photometry. Measurements of Luminous Intensity. Photometer Head. Distribution of Luminous Intensity. Determination of Mean Horizontal Luminous Intensity and Polar Curve. Determination of Mean Spherical Luminous Intensity. Calculation with a Distributed Source. Physical Photometry. Photo-emissive Cells. Photomultipliers. Photoconductive Transducers. Photoconductive Cells. Photodiodes. Phototransistors. Noise in Photoconductor Transducers. Photovoltaic Cell. Photocells in Physical Photometry. Measurement of Luminance. Unsolved Problems.

Chapter 20—Electronic Instruments

639—65

Electronic Voltmeters. Advantages of Electronic Voltmeters. Vacuum Tube Voltmeters (VTVMs). Average reading Diode Vacuum Tube Voltmeters. Peak reading Diode Vacuum Tube Voltmeters. Triode Vacuum Tube Voltmeters. Balanced Bridge Triode Vacuum Tube Voltmeter. Electrometer Type VTVM. Transistor Voltmeters (TVMs). TVM with Cascaded Transistors. TVMs Using FET as Input Stage. Chopper Amplifier Type Voltmeter. Balanced Bridge TVM. Differential Voltmeter. A.C. Voltage Measurements. R.M.S. Reading Voltmeter. Current Measurements Using Electronic Instruments. Instruments for Measurement of Power at Higher Frequencies.

Chapter 21—Cathode Ray Oscilloscope (CRO)

655—67

Introduction. Cathode Ray Tube (CRT). Electron Gun. Electrostatic Focusing. Electrostatic Deflection. Effect of Beam Transit Time and Frequency Limitations. Deflection Plates. Screens for CRTs. CRT Graticule. Time Base Generators. Basic CRO Circuits. Observation of Waveform on CRO. Measurement of Voltages and Currents. Measurements of Phase

and Frequency (Lissajous Patterns). Special Purpose Oscilloscopes. Multiple Beam Oscilloscopes. Multiple Trace Oscilloscopes. Sampling Oscilloscopes. Impulse Waveform Oscilloscopes. Scanning Oscilloscopes. Storage Type Oscilloscope. Accessories of Cathode Ray Oscilloscopes. Calibrators. Probes. Cameras. Electronic Switch. Unsolved Problems.

Chapter 22—Instruments for Generation and Analysis of Waveform

677—697

OSCILLATORS

Introduction. Classification of Oscillators. Feedback Oscillators. Types of Feedback Oscillators. RC Oscillators. Wien Bridge Oscillator. Practical Circuit of Wien Bridge Oscillator. Phase Shift Oscillator. L.C. Oscillators. Armstrong Oscillator. Hartley Oscillator. Colpitts Oscillator. Crystal Oscillators. Beat Frequency Oscillator (B.F.O). Negative Resistance Oscillators.

SIGNAL GENERATORS

Standard Signal Generator.

SQUARE WAVE GENERATORS

Types of Circuits. Passive Square Wave Generators, Diode Clipping Circuit. Overdriven Amplifier Circuit. Schmitt Trigger Circuit. Active Square Wave Generators.

FUNCTION GENERATORS

Introduction. Function Generator.

WAVE ANALYZERS

Introduction. Resonant Wave Analyzers. Hetrodyne Wave Analyzer or Wavemeter.

HARMONIC DISTORTION ANALYZERS

Introduction. Distortion Meters.

SPECTRUM ANALYZERS

Introduction. Basic Spectrum Analyzer. Spectral Displays. Spectra of Different Signals.

Chapter 23—High Frequency Measurements

698—714

Introduction. Resonance Methods. Measurement of Inductance Measurement of Capacitance. Measurement of Effective Resistance. Resistance Variation Method. Reactance Variation Method. T Networks. Parallel T Network. Bridge T Network. Q Meter. Vector-Impedance Meter. Measurement of Frequency. Unsolved Problems.

PART II

ELECTRICAL & ELECTRONIC INSTRUMENTATION

Chapter 24—Dynamic Characteristics of Instruments and Instrumentation Systems

716—547

Dynamic Response. Dynamic Behaviour. Time Domain Analysis. Frequency Domain Analysis. Mathematical Models of Instrumentation Systems. Linear and Non-Linear Systems :- Linear Time Invariant System. Linear Time Variant System. Analysis of Linear Systems. Electric Networks.

Mechanical Systems : Mechanical Translational Systems. Mechanical Rotational Systems. Analogous Systems. Thermal Systems. Transfer Function. Sinusoidal Transfer Function. Order of a System.

TIME DOMAIN RESPONSE]

Introduction. Zero Order System. First Order Systems. Thermal Systems. General First Order Differential Equation. Response of a First Order System to Unit Step Input. Ramp Response of a First Order System. Impulse Response of a First Order System. Time Response of a Second Order System. Time Domain Specifications. Ramp Response of a Second Order System. Impulse Response of a Second Order System.

FREQUENCY DOMAIN ANALYSIS

Introduction. Frequency response of a First Order System. Frequency Response of a Second Order System. Frequency Response Curves. Unsolved Problems.

Chapter 25—Transducers

746—825

Introduction. Primary and Secondary Transducers. Classification of Detector-Transducer Stage Devices. Mechanical Devices as Primary Detectors Mechanical Springs : Flat Spiral Spring. Torion Bars of Shafts. Proving Rings. Spring Flexure. Pivots. Pressure Sensitive Primary Devices. Bourdon Tubes. Diaphragms. Bellows. Temperature Detectors. Hydro-pneumatic Devices Electric Transducers. Advantages of Electrical Transducers. Classification of Electrical Transducers. Primary and Secondary Transducers. Primary Transducers. Secondary Transducers. Active and Passive Transducers. Active Transducers. Passive Transducers. Analog and Digital Transducers : Analog Transducers. Digital Transducers. Electrical Phenomena Used in Transducers. Resistive Transducers. Potentiometers : Loading Effect. Power Rating of Potentiometers. Linearity and Sensitivity. Construction of Potentiometers. Helipot. Types of Potentiometers and their Characteristics. Strain Gauges : Theory of Strain Gauges. Types of Strain Gauges. Resistance Wire Strain Gauges. Unbonded Strain Gauges. Bonded Resistance Wire Strain Gauges. Foil Strain Gauges. Semi-conductor Strain Gauges. Resistance Thermometers : Linear Approximation. Quadratic Approximation. Thermistors : Construction. Resistance Temperature Characteristics of Thermistors. Applications of Thermistors. Variable Inductance Type Transducers. Inductive Transducers Working on Principle of Variation of Self-Inductance. Transducers Working on Principle of Change in Self-Inductance with Number of turns. Transducers Working on the Principle of Change in Self-Inductance with Change in Geometric Configuration. Transducers Working on the Principle of Change in Self-Inductance with Change in Permeability Variable Reluctance Type Transducers. Differential Output. Inductive Transducers Working on Principle of Variation of Mutual Inductance. Inductive Transducers Working on the Principle of Production of Eddy Currents Linear Variable Differential Transformer (LVDT). Advantages of LVDTs. Disadvantages of LVDTs. Use of LVDTs. Rotary Variable Differential Transformer (RVDT). Synchros. Capacitive Transducers. Transducers Using Change in Area of Plates. Transducers Using Change in Distance Between Plates. Differential Arrangement. Variation of Dielectric Constant for Measurement of Displacement. Variation of Dielectric Constant for Measure-

ment of Liquid Level. Frequency Response of Capacitive Transducers. Advantages of Capacitive Transducers. Disadvantages of Capacitive Transducers. Uses of Capacitive Transducers. Piezo-electric Transducers. Modes of Operation of Piezo-electric Crystals. Properties of Piezo-electric Crystal. Equivalent Circuit of Piezo-electric Transducer. Loading Effect and Frequency Response. Impulse Response of Piezo-electric Crystals. Uses of Piezo-electric Materials and Transducers. Optical transducers. Hall effect Transducers. Ionization Transducers. Digital Transducer. Shaft Encoder. Unsolved Problems.

Chapter 26—Signal Conditioning

826—890

Signal Conditioning. Instrumentation Amplifiers. A.C. Amplifiers. Direct Coupled Amplifiers. Chopped and Modulated D.C. Amplifiers. Operational Amplifiers. Operational Amplifier Specifications. Operational Amplifier Circuits in Instrumentation. Inverter. Adder. Subtractor. Multiplier and Divider. Integrator. Differentiator. Attenuated Feedback. Ideal Rectifier. Logarithmic Converter. Buffer Amplifier. Differential Amplifier. Use of Operational Amplifier with Capacitive Displacement Transducers. Charge Amplifiers. Amplitude Modulation. Amplitude Demodulation. Amplitude Modulation and Demodulation Circuits For Measurement. Systems. Input Modulator. Demodulator. Filters. Types of Filters: Low Pass Filters. Bandpass Filters. Band Rejection (band stop) Filters. Filters With Cascaded Sections. LC Filters. Input Circuits. Current Sensitive Circuits. Ballast Circuit. Bridge Circuits. Wheatstone Bridge. Null Type Bridge. Deflection Type Bridge. Voltage Sensitive Bridge. Current sensitive Bridge. A.C. Bridges: A.C. Bridges using Push-Pull Transducers. A.C. Bridges with Push-Pull Inductive Transducers. Inductive Transducers Blumlein Bridge. Capacitive Transducers Blumlein Bridge. Integration and Differentiation. Low pass RC Filter as an Integrator. High Pass RC Filter as Differentiator. Analog/Digital/Analog Conversion Techniques. Resolution and quantization. Aperture Time. Sampling. General Considerations of A/D and D/A Conversion. Digital-to-analog (D/A) Conversion. D/A Converter. Analog to Digital (A/D) Conversion Techniques: Potentiometric A/D Converter. Voltage to time A/D Converter (Ramp type). Voltage-to-Frequency Converter (integrating type). Dual Slope Integration A/D Converter. Unsolved Problems.

Chapter 27—Data Transmission and Telemetry

891—908

Introduction. Methods of Data Transmission. Telemetry. General Telemetry System. Electrical Telemetry Systems. D.C. Telemetry Systems: Voltage Telemetry Systems. Current Telemetry Systems. Position Telemetry System. A.C. Telemetry Systems. Modulation: Amplitude Modulation (A.M.). Frequency Modulation (FM). Phase Modulation. Pulse Telemetry Systems. Analog Pulse Telemetry: Pulse Amplitude Modulation System (PAM). Pulse Frequency System. Pulse Duration Modulation (PDM). Pulse Position Modulation (PPM). Digital Telemetry (Pulse Code Modulation: PCM). Transmission Channels and Media: Wire Line Channels. Radio Channels. Microwave Channels. Power Line Carrier Channels. Multiplexing in Telemetry Systems: Time Division Multiplexing.

Chapter 28—Display Devices and Recorders

909—961

Introduction. Electrical Indicating Instruments. Digital Instruments: Advantages of Digital Instruments. Digital Versus Analog Instruments.

Electronic Counters: RS Flip-Flop. T and RST Flip-Flops. Decade Counter. Digital Display Methods. Digital Display Units. Segmental Displays: Seven Segmental Display. Fourteen Segmental Display. Dot Matrices: A 3×5 Dot Matrix. Dot Matrix Utilizing 27 Dots. A 5×7 Dot Matrix. Rear Projection Display. Nixie Tube. Light Emitting Diode (LED). Liquid Crystal Diodes (LCD). Nixie Tube. Segmental Gas Discharge Displays. Decade Counting Assembler (DCAs). Display Systems. Decimal Decoders: Diode. TTL Logic. BCD to 7-Segment Converter. BCD-to-Dot Matrix Converter. Resolution in Digital Meters. Sensitivity of Digital Meters. Accuracy Specification for Digital Meters.

DIGITAL FREQUENCY METER

Measurement of Frequency: Principle of Operation. Basic Circuit. Time base. Start and Stop Gate. Circuit for Measurement of Frequency. Simplified Composite Circuit of a Digital Frequency Meter. High Frequency Measurements. Period Measurement. Ratio and Multiple Ratio Measurements. Time Interval Measurement. Universal Counter Timer.

DIGITAL VOLTMETERS (DVMs)

Introduction. Types of DVMs. Ramp type Digital Voltmeter. Integrating type Digital Voltmeter. Potentiometric type Digital Voltmeter. Other Types of Measurements with a DVM.

RECORDERS

Necessity of Recorders. Recording Requirements. Analog Recorders. Graphic Recorders. Strip Chart Recorders. Types of Strip Chart Recorders. Galvanometer Type Recorders. Null type Recorders. Potentiometric Recorders. Single Point Recorders. Multipoint Recorders. X-Y Recorders. Ultraviolet Recorders: Principle of Operation. Recorder Galvanometers. Applications. Magnetic Tape Recorders. Advantages of Magnetic Tape Recorders. Basic Components of a Tape Recorder. Principle of Tape Recorders. Methods of Recording. Direct Recording: Advantages of Direct Recording. Disadvantages of Direct Recording. Frequency Modulated (FM) Recording: Advantages of FM Recording. Disadvantages of FM Recording. Pulse Duration Modulation (PDM) Recording: Advantages of PDM Recording. Disadvantages of PDM Recording. Digital Tape Recorders.

Chapter 29—Measurement of Non-Electrical Quantities

962-1047

MEASUREMENT OF LINEAR DISPLACEMENT

Linear Displacement Transducers.

MEASUREMENT OF ROTARY DISPLACEMENT

Rotary Displacement Transducers.

STRAIN GAUGES AND MEASUREMENT OF STRAIN

Strain Gauge Circuits. Ballast Circuit. Wheatstone Bridges: Null Type Wheatstone Bridge. Deflection type Wheatstone Bridges. Gauges Sensitivity. Temperature Compensation. Temperature Compensation and Cancellation Techniques: Adjacent Arm Compensating Gauge. Strain Gauge Calibration Load Cells. Tensile-Compressive Cells. Rosettes. Strain Gauge Circuitry. Uses of Strain Gauges.

MEASUREMENT OF PRESSURE

Introduction. Types of Pressure Measurement Devices. Measurement of Pressure Using Electrical Transducers as Secondary Transducers. Force Summing Devices. Secondary Transducers.

MEASUREMENT OF LOW PRESSURE

(Vacuum Measurements)

Vacuum Gauges. Thermocouple Vacuum Gauges. Pirani Gauges. Ionization Type Vacuum Gauge.

MEASUREMENT OF TORQUE

Torque Transducers. Strain Gauge Torque Meters. Inductive Torque Transducers. Digital Methods. Magneto-strictive Transducers.

MEASUREMENT OF LINEAR VELOCITY

Electromagnetic Transducers. Moving Magnet Type. Moving Coil Type Velocity Transducer.

MEASUREMENT OF ANGULAR VELOCITY

Introduction. Electrical Tachometers. Electromagnetic Tachometer Generators. Drag Cup Rotor A.C. Tachogenerator. Digital Methods. Photoelectric Tachometer. Toothed Rotor Variable Reluctance Tachometer. Stroboscope and Stroboscopic Methods. Strobotron. Shaft Speed Measurements. Advantages and Disadvantages of Stroboscopic Methods.

MEASUREMENT OF VIBRATIONS

Necessity for Measurement of Vibrations. Nature of Vibrations. Quantities involved in Vibration Measurements. Seismic Transducer. Types of Accelerometers. Potentiometric Type Accelerometer. LVDT Accelerometers. Piezo-electric Accelerometers.

MEASUREMENT OF TEMPERATURE

Temperature Measuring Devices. Electrical Resistance Thermometer. Platinum Resistance Thermometer. Measurement of Resistance of Thermometers. Salient Features of Resistance Wire Thermometers. Semi-conductor Thermometers.

Thermistors. Characteristics of Thermistors. Measurement of Temperature with Thermistors. Salient Features of Thermistors. Thermocouples. Thermocouple Construction. Measurement of Thermocouple Output. Compensating Circuits. Reference junction Compensation. Lead Compensation. Advantages and Disadvantages of Thermocouples. Quartz Crystal Thermometer. Radiation Pyrometers. Principles Used for Radiation Temperature Measuring Devices. Radiation Receiving Elements. Total Radiation Pyrometers. Infrared Pyrometer. Optical Pyrometers.

MEASUREMENT OF FLOW

Rate of Flow. Turbine Meters. Electromagnetic Flow Meters. Hot Wire Anemometers. Flow Meter Using Thermistors. Electrical Methods: Resistive Method. Inductive Methods. Capacitive Methods. Measurement of Liquid Level with Gamma Rays. Ultrasonic Methods. Measurement of

Liquid Level Using Float.

MEASUREMENT OF THICKNESS

Electrical Methods. Inductive Methods. Capacitive Method. Measurement of Thickness Using Ultrasonic Vibrations. Nuclear Radiation Method.

MEASUREMENT OF HUMIDITY

Humidity. Hygrometers.

MEASUREMENT OF SOUND USING HYGROMETERS

Microphones. Types of Microphones.

CHEMICAL SENSORS

Measurement of pH Values. Measurement of Thermal Conductivity.

NUCLEAR INSTRUMENTATION

Measurement of Radiations. Introduction. Types of Radiations. Geiger Müller Tube. Ionization Chamber Scintillation Counters. Solid State Ionization Sensing Elements. Detection of Neutrons. Unsolved Problems.

Chapter 30—Data—Acquisition Systems

1048—1056

Instrumentation Systems. Types of Instrumentation Systems. Components of an Analog Data-Acquisition System. Components of a Digital Data-Acquisition System. Uses of Data Acquisition Systems. Use of Recorders in Digital Systems. Digital Recording Systems: Input Conditioning Equipment. Digitiser. Multiplexer. Programme Pinboard. Lineariser. Digital Clock. Limit Detectors. Output Devices. Mini computers and Microprocessors.

Appendix A

1057—1069

NUMBER SYSTEMS

Number Systems. Decimal Number System. A General Number System. Binary Number System. Binary to Decimal Conversion. Decimal to Binary Conversion. Arithmetic Processes in a Binary System: Binary Addition. Binary Subtraction. Multiplication of Binary Numbers. Division of Binary Numbers. Binary Coded Decimal Systems (BCD). The 8—4—2—1 Code. Other BCD Codes Gray Code. Conversion from Binary to Gray Code. Gray Code to Binary Conversion.

Appendix B

1070—1073

LOGIC GATES

Introduction. Gate. OR Gate. Truth Table. Logic Conversion. AND Gate. NOT Gate. NOR Gate. NAND Gate.

Appendix C

1074—1075

PART I
ELECTRICAL AND ELECTRONIC MEASUREMENTS
AND
MEASURING INSTRUMENTS

Measurements and Measurement Systems

1.1. Measurements

The measurement of a given quantity is essentially an act or the result of comparison between the quantity (whose magnitude is unknown) and a predefined standard. Since two quantities are compared the result is expressed in numerical values.

In order that the results of the measurement are meaningful, there are two basic requirements :

(i) The standard used for comparison purposes must be accurately defined and should be commonly accepted,

and (ii) The apparatus used and the method adopted must be provable.

1.2. Significance of Measurements

The advancement of Science and Technology is dependent upon a parallel progress in measurement techniques. It can be safely said that the quickest way to assess a nation's progress in Science and Technology is to examine the type of measurements that are being made and the way in which the data is acquired by measurements and is processed.

The reasons for this are obvious. As Science and Technology move ahead, new phenomena and relationships are discovered and these advances make new types of measurements imperative. New discoveries are not of any practical utility unless they are backed by actual measurements. The measurements, no doubt, confirm the validity of a hypothesis but also add to its understanding. This results in an unending chain which leads to new discoveries that require more, new and sophisticated measurement techniques. Hence modern Science and Technology are associated with sophisticated methods of measurement while elementary Science and Technology require only ordinary methods of measurement.

There are two major functions of all branches of engineering :

(i) Design of equipment and processes,

and (ii) Proper operation and maintenance of equipment and processes.

Both these functions require measurements. This is because proper and economical design, operation and maintenance require a feedback of information. This information is supplied by making suitable measurements.

1.3. Methods of Measurement

The methods of measurement may be broadly classified into two categories.

1.3.1. Direct Methods. In these methods, the unknown quantity (also called the measurand) is directly compared against a standard. The result is expressed as a numerical number and a unit. The standard, in fact, is a physical embodiment of a unit. Direct methods are quite common for the measurement of physical quantities like length, mass and time.

Suppose we want to measure the length of a bar. The unit of length is metre. A bar is so many times long because that many units on our standard have the same length as the bar. A human being can make direct length comparisons with a preciseness of about 0.25 mm. Therefore, on account of human factors it is not possible to make very accurate measurements. The direct method for measurement of length can be utilized with a good degree of accuracy but when it comes to measurement of mass, the problem becomes much more intricate. It is just not possible for human beings to distinguish between wide margins of mass.

1.3.2. Indirect Methods. Measurement by direct methods are not always possible, feasible and practicable. These methods in most of the cases, are inaccurate because they involve human factors. They are also less sensitive. Hence direct methods are not preferred and are rarely used.

In engineering applications Measurement Systems are used. These measurement systems use indirect methods for measurement purposes.

A measurement system consists of a transducing element which converts the quantity to be measured in an analogous form. The analogous signal is then processed by some intermediate means and is then fed to the end devices which present the results of the measurement.

1.4. Instrument

Measurement generally involves using an instrument as a physical means of determining a quantity or variable. The instrument serves as an extension of human faculties and enables the man to determine the value of an unknown quantity which his unaided human faculties cannot measure.

An instrument may be defined as a device for determining the value or magnitude of a quantity or variable.

1.5. Mechanical, Electrical and Electronic Instruments

The first instruments were mechanical in nature and the principles on which these instruments worked are even in vogue today. The earliest scientific instruments used the same three essential elements as our modern instruments do. These elements are :

(i) a detector, (ii) an intermediate transfer device, and (iii) an indicator, recorder or a storage device.

The history of development of instruments encompasses three phases of instruments, viz. : (i) mechanical instruments, (ii) electrical instruments and (iii) electronic instruments.

1.5.1. Mechanical Instruments. These instruments are very reliable for static and stable conditions. But they suffer from a very major disadvantage. They are unable to respond rapidly to measurements of dynamic and transient conditions. This is due to the fact that these instruments have moving parts that are rigid, heavy and bulky and consequently have a large mass. Mass presents inertia problems and hence these instruments cannot faithfully follow the rapid changes which are involved in dynamic measurements. Thus it would be virtually impossible to measure a 50 Hz voltage by a mechanical method, but it is relatively easy to measure a slowly varying pressure. Another disadvantage of mechanical instruments is that most of them are a potential source of noise and cause pollution of silence.

1.5.2. Electrical Instruments. Electrical methods of indicating the output of detectors are more rapid than mechanical methods. It is unfortunate that an electrical system normally depends upon a mechanical meter movement as indicating device. This mechanical movement has some inertia and therefore these instruments have a limited time (and hence, frequency) response. For example, some electrical recorders can give full scale response in 0.2 s, the majority of industrial recorders have responses of 0.5 to 24 s. Some galvanometers can follow 50 Hz variations, but even these are too slow for present day requirements of fast measurement.

1.5.3. Electronic Instruments. These days most of the scientific and industrial measurements require very fast responses. The mechanical and electrical instruments and systems cannot cope up with these requirements. The necessity to step up response time and also the detection of dynamic changes in certain parameters, which require the monitoring time of the order of ms and many a times, μ s, have led to the design of today's electronic instruments and their associated circuitry. These instruments require vacuum tubes or semi-conductor devices. Recent practice is to use semi-conductor devices as they have many advantages over their vacuum tube counterparts. Since in electronic devices, the only movement involved is that of electrons, the response time is extremely small on

account of very small inertia of electrons. For example, a C.R.O. is capable of following dynamic and transient changes of the order of a few ns (10^{-9} s).

Electronically controlled power supplies are used to provide stable voltages for studies in the field of chemical reactions and nuclear instrumentation. Electronic instruments are steadily becoming more reliable on account of improvements in design and manufacturing processes of semi-conductor devices. Another advantage of using electronic devices is that very weak signals can be detected by using pre-amplifiers and amplifiers. The foremost importance of the electronic instruments is the power amplification provided by the electronic amplifiers. Additional power may be fed into the system to provide an increased power output beyond that of the input. This has been only possible through the use of electronic amplifiers, which have no important mechanical counterpart. This is particularly important where the data presentation devices use stylus type recorders, galvanometers, cathode ray oscilloscopes and magnetic tape recorders.

It is a fact that hydraulic and pneumatic systems may be used for power amplification of signals. However, their use is limited to slow acting control applications like servo-systems, chemical processes and power systems. Electronic instruments find extensive use in detection of electromagnetically produced signals such as radio, video, and microwave. Electrical and electronic instruments are particularly useful in the intermediate signal modifying stage. Electronic instruments are light compact and have a high degree of reliability. Their power consumption is very low.

Communications is a field which is entirely dependent upon the electronic instruments and associated apparatus. Space communications, especially, makes use of air borne transmitters and receivers and job of interpreting the signals is left entirely to the electronic instruments.

Electronic instruments make it possible to build analog and digital computers without which the modern developments in science and technology are virtually impossible. Computers require a very fast time response and it is only possible with use of electronic instruments.

1.6. Classification of Instruments

There are many ways in which instruments can be classified. Broadly, instruments are classified into two categories :

- (1) Absolute Instruments, and (2) Secondary Instruments.

1. Absolute Instruments. These instruments give the magnitude of the quantity under measurements in terms of physical constants of the instrument. The examples of this class of instruments are Tangent Galvanometer and Rayleigh's current balance.

2. Secondary Instruments. These instruments are so constructed that the quantity being measured can only be measured by observing the output indicated by the instrument. These instruments are calibrated by comparison with an absolute instrument or another secondary instrument which has already been calibrated against an absolute instrument.

Working with absolute instruments for routine work is time consuming since every time a measurement is made, it takes a lot of time to compute the magnitude of the quantity under measurement. Therefore secondary instruments are most commonly used. Absolute instruments are seldom used except in standards institutions while secondary instruments find usage almost in every sphere of measurement. A voltmeter, a glass thermometer and a pressure gauge are typical examples of secondary instruments.

1.7. Analog and Digital Modes of Operation. Secondary instruments work in two modes :

- (i) Analog mode, and (ii) Digital mode.

Signals that vary in a continuous fashion and take on an infinity of values in any given range are called analog signals. The devices which produce these signals are called analog devices.

In contrast, the signals which vary in discrete steps and thus take up only finite different values in a given range are called digital signals. The devices that produce such signals are called digital devices.

Let us elaborate further on Digital and Analog instruments and systems. In an analogue system the function varies continuously. A typical example of variation is shown in Fig. 1'1. On the other hand the digital values are discrete and vary in equal steps. Each digital number is a fixed sum of equal steps which is defined by the number.

In order to convert an analog quantity into a digital number, the vertical displacements must be divided into equal parts. For example in Fig. 1'1, the vertical quantities are divided into 10 equal parts and each part has a length of 1 unit. When dealing with digital numbers, a quantity between 0 to 0.5 is 0 while a quantity between 0.5 to 1.5 is 1 and a quantity between 1.5 to 2.5 is 2. For example a point A on the analogue curve is 5.5 from the origin but in digital system it would be read as 5. From A to B is 6 and from B to C is 7. It apparently seems that if we adopt digital system, the errors involved will be considerable. But if we divide each of the 10 steps into 10 equal parts, we get 100 steps instead of 10. And if these 100 steps are further divided into 10 parts each, we will have 1000 steps. This gives much better accuracy in converting analogue quantities into digital numbers. We can go on subdividing further and further till the desired accuracy is achieved. But it should be kept in mind that a digital number is still a sum of equal units.

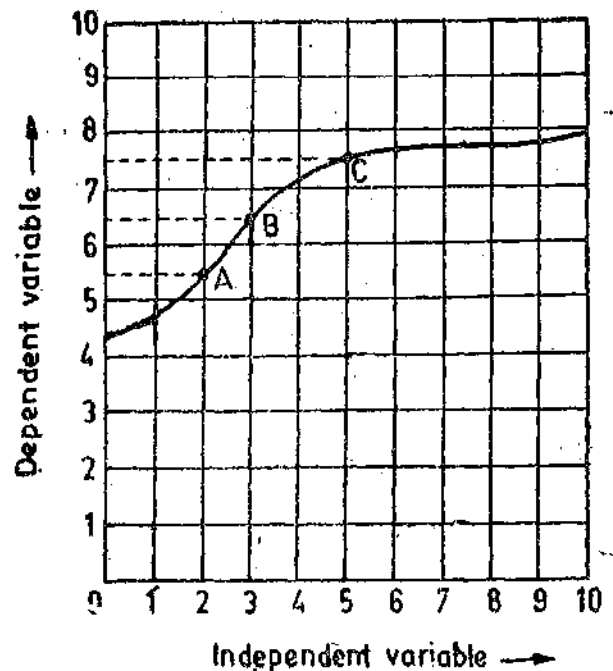

Fig. 1'1. Representation of an analogue quantity.

In a digital system, magnitudes lying within one of these steps lose their identity and are all defined by the same number. For example, if we have ten steps, numbers lying between 2.5 to 3.5 i.e., 2.6, 2.7, 2.8, 2.9, 3.0, 3.1, 3.2, 3.3, 3.4, would all be read as 3.

From the above discussion we conclude that the difference between analog and digital information is that the analog output is a continuous function while the digital output is a discrete number of units. The last digit of any digital number is rounded to ± 0.5 of the last digit. It should also be marked that the magnitude of the digital quantity is measured only at the instant the reading is taken. One reading persists till another reading is taken (unlike the analogue quantity which is a continuous function).

The majority of present day instruments are analogue type. The importance of digital instruments is increasing, mainly because of the increasing use of digital computers in both data reduction and automatic control systems. Since digital computer works only with digital signals, any information supplied to it must be in digital form. The computer's output is also in digital form. Thus working with a digital computer at either the input or the output, we must use digital signals.

However, most of our present day measurement and control apparatus produces signals of analog nature, it is thus necessary to have both Analog to Digital (A/D) Converters at the input to the computer and Digital to Analog (D/A) Converters at the output of the computer.

1'8. Functions of Instruments and Measurement Systems

There is another way in which instruments or measurement systems may be classified. This classification is based upon the functions they perform. The three main functions are explained below:

1. **Indicating Function.** Instruments and systems use different kinds of methods for supplying information concerning the variable quantity under measurement. Most of the time this information is obtained as a deflection of a pointer of a measuring instrument. In this way the instrument performs a function which is commonly known as **indicating function**. For example, the deflection of pointer of a speedometer indicates the speed of the automobile at that moment. A pressure gauge is used for indicating pressure.

2. **Recording Function.** In many cases the instrument makes a written record, usually on paper, of the value of the quantity under measurement against time or against some other variable. Thus the

instrument performs a recording function. For example, a potentiometric type of recorder used for monitoring temperature records the instantaneous temperatures on a strip chart recorder.

3. Controlling Function. This is one of the most important functions especially in the field of industrial control processes. In this case, the information is used by the instrument or the system to control the original measured quantity.

Thus there are three main groups of instruments. The largest group has the indicating function. Next in line is the group of instruments which have both indicating and or recording functions. The last group falls into a special category and performs all the three functions, i.e., indicating, recording and controlling.

In this text, main emphasis is laid upon instruments whose functions are mainly indicating and recording, especially those instruments which are used for engineering analysis purposes. The control function will be analyzed in those cases where controlling enters as an integral part of the indicating and recording functions of instrumentation.

The examples of controlling instruments are thermostats for temperature control and floats for liquid level control.

1.9. Applications of Measurement Systems

In order to build up background for our later detailed study of measuring instruments and systems and their characteristics, it is useful to discuss, in general, the various ways these instruments are put in use. The way the instruments and measurement systems are used for different applications are as under :

1. Monitoring of processes and operations.
2. Control of processes and operations.
3. Experimental Engineering analysis.

1. Monitoring of Processes and Operations. There are certain applications of measuring instruments that have essentially a monitoring function. They simply indicate the value or condition of parameter under study and their readings do not serve any control functions. For example, an ammeter or a voltmeter indicates the value of current or voltage being monitored (measured) at a particular instant. Similarly, water and electric energy meters installed in homes keep track of commodity used so that later on its cost may be computed to be realized from the user.

2. Control of Processes and Operations. A very useful application of instruments is in automatic control systems. There has been a very strong association between measurement and control.

In order that process variables like temperature, pressure, humidity, etc. may be controlled, the prerequisite is that they can be measured at the desired location in the individual plants. Same is true of servo-systems, i.e., systems connected with measurement of position, velocity and acceleration.

A block diagram of a simple control system is shown in Fig. 1'2. Let us assume that the output variable to be controlled is non-electrical and the control action is through electrical means.

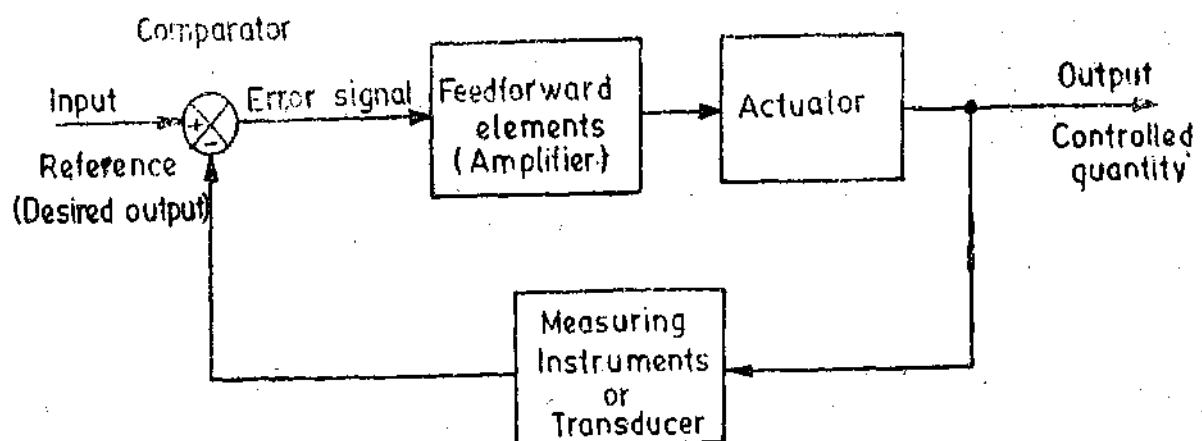

Fig. 1'2. Block diagram of a simple control system.

The input is reference which corresponds to the desired value of the output. The input is compared with the output with the help of a comparator. The output is a non-electrical quantity and is converted into a corresponding electrical form by a transducer connected in the feedback loop. In case the input and output differ, there is a resultant error signal. This error signal is amplified and then fed to an actuator, which produces power to drive the controlled circuitry.

The corrective action goes on till the output is at the same level as the input which corresponds to the desired output. At this stage, there is no error signal and hence there is no input to the actuator and the control action stops.

Examples of this type of application are numerous. A common one is the typical refrigeration system which employs a thermostatic control. A temperature measuring device (often a bimetallic element) senses the room temperature, thus providing the information necessary for proper functioning of the control system.

3. Experimental Engineering Analysis. For solution of engineering problems, theoretical and experimental methods are available. Many applications require application of both the methods. The relative applicability of the method depends upon the nature of the problem. Experimental engineering analysis has many uses and some are listed below :

1. Testing the validity of theoretical predictions.
2. Formulations of generalized empirical relationships in cases where no proper theoretical backing exists.
3. Determination of system parameters, variables and performance indices.
4. For development in important spheres of study where there is ample scope of study.
5. Solutions of mathematical relationships with the help of analogies.

1.10. Elements of a Generalized Measurement System

It is important to have a systematic organization and analysis of measurement systems. An instrument may be defined as a device or a system which is designed to maintain a functional relationship between prescribed properties of physical variables and must include ways and means of communication to a human observer. The functional relationships remain valid only as long as the static calibration of system remains constant. On the other hand, the performance of a measurement system can be described in terms of static and dynamic characteristics.

It is possible and desirable to describe the operation of a measuring instrument or a system in a generalized manner without resorting to intricate details of the physical aspects of a specific instrument or a system. The whole operation can be described in terms of functional elements.

Most of the measurement systems contain three main functional elements. They are :

1. Primary Sensing Element,
2. Variable Conversion Element, and
3. Data Presentation Element.

Each functional element is made up of a distinct component or groups of components which perform required and definite steps in the measurement. These may be taken as basic elements, whose scope is determined by their functioning rather than their construction.

1. Primary Sensing Element. The quantity under measurement makes its first contact with the primary sensing element of a measurement system. In other words the measurand is first detected by primary sensor. This act is then immediately followed by the conversion of measurand into an analogous electrical signal. This is done by a transducer. A transducer in general, is defined as a device which converts energy from one form to another. But in measurement systems, this definition is limited in scope. A transducer is defined as a device which converts a physical quantity into an electrical quantity. The physical quantity to be measured, in the first place is sensed and detected by an element which gives the output in a different analogous form. This output is then converted into an electrical signal by a transducer. This is true of most of the cases but is not true for all. In many cases the physical quantity is directly converted into an electrical quantity by a transducer. However, the first stage of a measurement system is known as a detector transducer stage.

2. **Variable Conversion Element.** The output of the primary sensing element may be any kind of electrical signal. It may be a voltage, a frequency or some other electrical parameter. Sometimes this output is not suited to the system. For the instrument to perform the desired function, it may be necessary to convert this output to some other suitable form while preserving the information content of the original signal. We may cite an example. Suppose output is in analogue form and the next stage of the system accepts input signal only in digital form. Therefore we will have to use an A/D converter.

Many instruments do not need any variable conversion element, while others need more than one element.

Variable Manipulation Element. The function of this element is to manipulate the signal presented to it preserving the original nature of the signal. Manipulation here means a change in numerical value of the signal. For example, an electronic amplifier accepts a small voltage signal

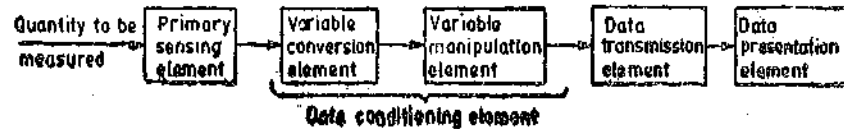

Fig. 1'3. Functional elements of an instrumentation system.

as input and produces an output signal which is also voltage but of greater magnitude. Thus voltage amplifier acts as a variable manipulation element. It is not necessary that a variable manipulation element should follow the variable conversion element as shown in Fig. 1'3. It may precede the variable conversion element in many cases.

As discussed earlier, the output of transducers contains information needed for further processing by the system and the output signal is usually a voltage or some other kind of electrical signal. The two most important properties of voltage are its magnitude and frequency though polarity may be a consideration in some cases. Many transducers develop low voltages of the order of mV and some even μ V. A fundamental problem is to prevent this signal being contaminated by unwanted signals like noise due to an extraneous source which may interfere with the original output signal. Another problem is that the signal may not be distorted by processing equipment. The signal after being sensed cannot be directly transmitted to the next stage without removing the interfering sources, as otherwise we may get highly distorted results which are far from true. Many a times we have to perform certain operations on the signal before it is transmitted further. These processes may be linear like amplification, attenuation, integration, differentiation, addition and subtraction. Some non-linear processes like modulation, detection, sampling, filtering, chopping and clipping etc. are performed on the signal to bring it to the desired form. This is called **Signal Conditioning**. The term signal conditioning includes many other functions in addition to variable conversion and variable manipulation. In fact the element that follows the primary sensing element in any instrument or instrumentation system should be called **Signal Conditioning Element**.

When the elements of an instrument are actually physically separated, it becomes necessary to transmit data from one to another. The element that performs this function is called a **Data Transmission Element**. For example space-crafts are physically separated from the earth where the control stations guiding their movements are located. Therefore control signals are sent from these stations to space-crafts by a complicated telemetry systems using radio signals.

The signal conditioning and transmission stage is commonly known as **Intermediate Stage**.

3. **Data Presentation Element.** The information about the quantity under measurement has to be conveyed to the personnel handling the instrument or the system for monitoring, control, or analysis purposes. The information conveyed must be in a form intelligible to the personnel. This function is done by data presentation element. In case data is to be monitored, visual display devices are needed. These devices may be analogue or digital indicating instruments like ammeters, voltmeters etc. In case the data is to be recorded, recorders like magnetic tapes, high speed camera and T.V. equipment, storage type C.R.T., printers, analogue and digital computers may be used. For control and analysis purpose computers may be used.

The final stage in a measurement system is known as

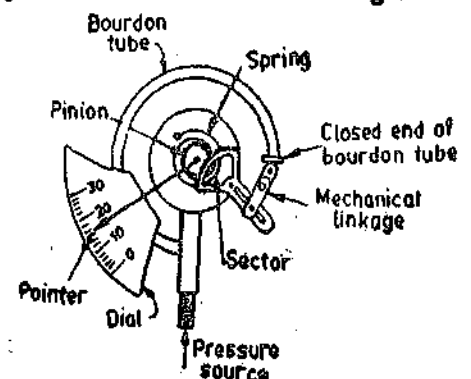

Fig. 1'4. Bourdon tube pressure gauge.

terminating stage. As an example of a measurement system, consider the simple bourdon tube pressure gauge as shown in Fig. 1'4. This gauge offers a good example of a measurement system. In this case the bourdon tube acts as the primary sensing element and a variable conversion element. It senses the input quantity (pressure in this case). On account of the pressure the closed end of the bourdon tube is displaced. Thus the pressure is converted into a small displacement. The closed end of the bourdon tube is connected through mechanical linkage to a gearing arrangement. The gearing arrangement amplifies the small displacement and makes the pointer to rotate through a large angle. The mechanical linkage thus acts as a data transmission element while the gearing arrangement acts as a data manipulation element.

The final data presentation stage consists of the pointer and dial arrangement, which when calibrated with known pressure inputs, gives an indication of the pressure signal applied to the bourdon tube. The schematic diagram of this measurement system is given in Fig. 1'5.

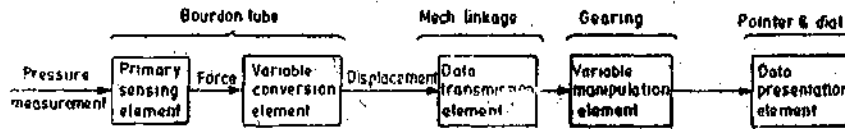

Fig. 1'5. Schematic diagram of a bourdon tube pressure gauge.

When a control device is used for the final measurement stage, it is necessary to apply some feedback to the input signal to accomplish the control objectives. The control stage compares the signal representing the measured variable with a reference signal of the same form. This reference signal has a value the measured signal should have and is presented by a controller. If the measured signal agrees with the reference value, the controller does nothing. However, if there is a difference between the measured value and the reference value, an error signal is generated. Thus the controller sends a signal to a device which acts to alter the value of the measured signal. Suppose the measured variable is flow of a liquid, then the control device is a motorized valve placed in the flow system. In case the measured flow rate is too low than the preset flow rate, then the controller would cause the valve to open, thereby increasing the flow rate. If on the other hand, the flow rate were too high, the valves are closed. The operation of closing or opening of valve will cease when the output flow rate is equal to preset value of flow rate.

Characteristics of Instruments and Measurement Systems

2.1. Measurement System Performance

The treatment of instrument and measurement system characteristics can be divided into two distinct categories viz. :

(i) Static characteristics, and (ii) Dynamic characteristics.

Some applications involve the measurement of quantities that are either constant or vary very slowly with time. Under these circumstances it is possible to define a set of criteria that gives a meaningful description of quality of measurement without interfering with dynamic descriptions that involve the use of differential equations. These criteria are called **Static Characteristics**.

Normally static characteristics of a measurement system are, in general, those that must be considered when the system or instrument is used to a condition not varying with time.

However many measurements are concerned with rapidly varying quantities and, therefore, for such cases we must examine the dynamic relations which exist between the output and the input. This is normally done with the help of differential equations. Performance criteria based upon dynamic relations constitute the **Dynamic Characteristics**.

2.2. Static Calibration

All the static performance characteristics are obtained in one form or another by a process called **static calibration**.

The calibration of all instruments is important since it affords the opportunity to check the instrument against a known standard and subsequently to errors in accuracy. Calibration procedure involve a comparison of the particular instrument with either (1) a primary standard, (2) a secondary standard with a higher accuracy than the instrument to be calibrated, or (3) an instrument of known accuracy.

Actually all working instruments, *i.e.*, those instruments which are actually used for measurement work must be calibrated against some reference instruments which have a higher accuracy. The reference instruments in turn must be calibrated against instrument of still higher grade of accuracy or against primary standard, or against other standards of known accuracy. It is essential that a measurement made must ultimately be traceable to the relevant primary standards.

2.3. Static Characteristics

The main static characteristics discussed here are :

- | | | |
|--------------|-----------------------|-----------------------|
| (i) Accuracy | (ii) Sensitivity, | (iii) Reproducibility |
| (iv) Drift | (v) Static error, and | (vi) Dead Zone |

The qualities (i), (ii) and (iii) are desirable, while qualities (iv), (v) and (vi) are undesirable. In addition to above characteristics, definitions of many other quantities have been given.

It must be stated, however, that there are many definitions of the above characteristics, and

some cases the definitions are unrelated. Care has been taken to select the most generally accepted definitions so as to avoid confusion.

2.4. Errors in Measurements

Measurements done in a laboratory or at some other place always involve errors. No measurement is free from errors. If the precision of the equipment is adequate, no matter what its accuracy is, a discrepancy will always be observed between two measured results.

In ordinary usage, the word error may have certain unpleasant connotations. It may imply a mistake, a moral offence, or possibly a belief in something untrue. In its extreme, it may be a blunder. But errors are to be there in measurements and therefore there is nothing shameful about them as it should be understood that no measurement is free from errors.

Since errors are a must in any measurement, it is imperative to interpret the results of a quantitative measurement in an intelligent manner. An understanding and thorough evaluation of the errors is essential.

2.5. True Value

The true value of quantity to be measured may be defined as the average of an infinite number of measured values when the average deviation due to the various contributing factors tends to zero. Such an ideal situation is impossible to realise in practice and hence it is not possible to determine the "True Value" of a quantity by experimental means. The reason for this is that the positive deviations from the true value do not equal the negative deviations and hence do not cancel each other.

Thus, normally an experimenter would never know that the value or quantity being measured by experimental means is the "True Value" of the quantity or not.

In fact in practice, the term, "True Value", then, refers to a value that would be obtained if the quantity under consideration were measured by an "Exemplar Method", that is a method agreed upon by experts as being sufficiently accurate for the purposes to which the data will ultimately be put to use.

2.6. Static Error

The most important characteristic of an instrument or measurement system is its accuracy, which is the agreement of the instrument reading with the true value of quantity being measured. The accuracy of an instrument is measured in terms of its error.

We have mentioned earlier that it is impossible to measure the true value of a quantity. An approximation of the "true value" obtained by sufficiently extended series of measurements and also taking into account parameters and conditions to which corrections may be applied, we obtain, what is called the best measured value of the quantity. While it is never possible to measure the true or exact value of a quantity, it is nearly always possible to give a best measured value. Static error is defined as the difference between the measured value and the true value of the quantity. Then :

$$\delta A = A_m - A_t \quad \dots(2.1)$$

where

$$\delta A = \text{error,}$$

$$A_m = \text{measured value of quantity,}$$

and

$$A_t = \text{true value of quantity.}$$

δA is also called the absolute static error of quantity A .

$$\text{We have} \quad \epsilon_0 = \delta A \quad \dots(2.2)$$

where ϵ_0 = absolute static error of quantity A (under measurement).

The absolute value of δA does not indicate precisely the accuracy of measurements. As an example, an error of ± 2 A is negligible when the current being measured is of the order of 1000 A while the same error of ± 2 A may be regarded as intolerable when the current under measurement is 10 A or so. Thus the quality of measurement is provided by the relative static error, i.e., the ratio

of absolute static error δA to the true value A_t of the quantity under measurement. Therefore, the relative static error ϵ_r is given by :

$$\epsilon_r = \frac{\text{absolute error}}{\text{true value}} = \frac{\delta A}{A_t} = \frac{\epsilon_0}{A_t} \quad \dots(2'3)$$

$$\text{Percentage static error } \% \epsilon_r = \epsilon_r \times 100 \quad \dots(2'4)$$

$$\text{We have } A_t = A_m - \delta A \quad (\text{see Eqn. 2'1})$$

$$= A_m - \epsilon_0 = A_m - \epsilon_r A_t \quad (\text{see Eqns. 2'2, 2'3})$$

$$= \frac{A_m}{1 + \epsilon_r} \quad \dots(2'5)$$

However, when the absolute static error $\epsilon_0 = \delta A$ is small, which means that the difference between measured and true values is small.

$$\epsilon_r \ll 1$$

$$\therefore \text{Eqn. 2'5 may be written as } A_t = A_m(1 - \epsilon_r) \quad \dots(2'6)$$

2'7. Static Correction

It is the difference between the true value and the measured value of the quantity, or

$$\delta C = A_t - A_m \quad \dots(2'7)$$

$$\text{where } \delta C = \text{static correction} = -\delta A \quad \dots(2'8)$$

Example 2'1. A meter reads 127.50 V and the true value of the voltage is 127.43 V. Determine :

(a) the static error, and (b) the static correction for this instrument.

Solution. From Eqn. 2'1, the error is

$$\delta A = A_m - A_t = 127.50 - 127.43 = +0.07 \text{ V}$$

$$\text{Static correction } \delta C = -\delta A = -0.07 \text{ V.}$$

Example 2'2. A thermometer reads 95.45°C and the static correction given in the correction curve is -0.08°C. Determine the true value of the temperature.

$$\text{Solution. True value of the temperature } A_t = A_m + \delta C = 95.45 - 0.08 = 95.37^\circ\text{C.}$$

Example 2'3. A voltage has a true value of 1.50 V. An analog indicating instrument with a scale range of 0-2.50 V shows a voltage of 1.46 V. What are the values of absolute error and correction. Express the error as a fraction of the true value and the full scale deflection (f.s.d.).

$$\text{Solution : Absolute error } \delta A = A_m - A_t = 1.46 - 1.50 = -0.04 \text{ V}$$

$$\text{Absolute correction } \delta C = -\delta A = +0.04 \text{ V}$$

$$\text{Relative error } \epsilon_r = \frac{\delta A}{A_t} = \frac{-0.04}{1.50} \times 100 = -2.66\%$$

Relative error (expressed as a percentage of f.s.d.)

$$= \frac{-0.04}{2.5} \times 100 = -1.60\%$$

2'8. Scale Range and Scale Span

In an analog indicating instrument the value of measurand is indicated on a scale by a pointer while in a recording instrument it is indicated on a chart by a pen mechanism. The choice of proper range instruments is important in instrumentation. The Scale Range of an instrument is defined as the difference between the largest and the smallest reading of the instrument. Supposing the highest point of calibration is X_{max} units while the lowest is X_{min} units and that the calibration is continuous between the two points. Then we can say that the instrument range is between X_{min} and X_{max} (or many a times we say that the instrument range is X_{max}).

The instrument span is given by : $\text{Span} = X_{max} - X_{min}$... (2.9)

For a pyrometer calibrated between 0 to 1000°C, the range is 1000°C and span is 1000°C. For a thermometer calibrated between 200°C to 500°C, the range is 200°C to 500°C (or 500°C) but the span is $500 - 200 = 300^\circ\text{C}$.

The same is true of digital instruments.

The accuracy of an instrument may be expressed in many ways. A common way is to specify "accurate to within x per cent." This means that the instrument is "accurate to within ±x percent of instrument span at all points on the scale unless and otherwise specified." However, often accuracy is based upon instrument range and these two specifications, one based on span and the other on range differ greatly.

There is another factor that must be considered while determining the range of the instrument. This is the Frequency Range, which is defined as frequencies over which measurements can be performed with a specified degree of accuracy. For example a moving iron instrument may have a 0-250 V range and 0-135 Hz frequency range with an accuracy of 0.5 or 1% of full scale reading.

Example 2.4. A thermometer is calibrated 150°C to 200°C. The accuracy is specified within ±0.25 percent. What is the maximum static error.

Solution : Span of thermometer = $200 - 150 = 50^\circ\text{C}$.

$$\therefore \text{Maximum static error} = \frac{\pm 0.25 \times 50}{100} = \pm 0.125^\circ\text{C}.$$

2.9. Error Calibration Curve

Error calibration means that an instrument has been calibrated against a suitable standard as discussed in Art. 2.2 and its static error determined at a number of points on its scale. These data form an error curve, which can be used for correcting instrument readings. A typical error curve is shown in Fig. 2.1.

2.10. Reproducibility and Drift

Reproducibility. It is the degree of closeness with which a given value may be repeatedly measured. It may be specified in terms of units for a given period of time. Perfect reproducibility means that the instrument has no drift. No drift means that with a given input the measured values do not vary with time.

Drift is an undesirable quality in industrial instruments because it is rarely apparent and cannot be easily compensated for. Thus it must be carefully guarded against by continuous prevention, inspection and maintenance. For example, stray electrostatic and electromagnetic fields can be prevented from affecting the measurements by proper shielding. Effect of mechanical vibrations can be minimized by having proper mountings. Temperature changes during the measurement process should be preferably avoided or otherwise be properly compensated for.

2.11. Repeatability

Reproducibility and Repeatability are a measure of closeness with which a given input may be measured over and over again. The two terms cause confusion. Therefore, a distinction is made between the two terms. **Reproducibility** is specified in terms of scale readings over a given period of time. On the other hand, **Repeatability** is defined as the variation of scale reading and is random in nature. Fig. 2.2 shows this repeatability.

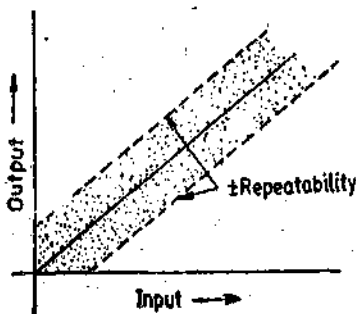

Fig. 2.2. Input-output relationship with ± repeatability.

2.12. Noise. Noise may be defined as any signal that does not convey any useful information. Extraneous disturbances generated in the measuring system itself or coming from outside, frequently constitute a background against which a signal may be read.

There are many sources of noise. Noise may originate at the primary sensing device, in a communication channel or other intermediate links. The noise may also be produced by indicating elements of the system.

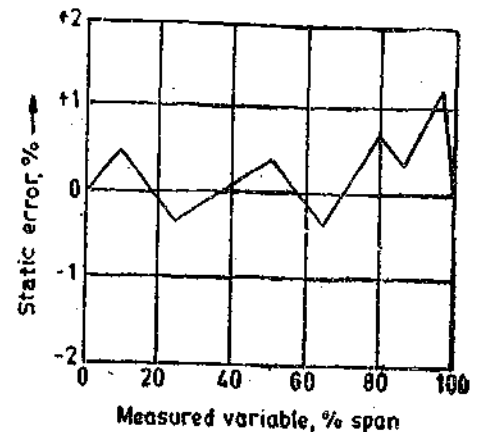

Fig. 2.1 Error calibration curve.

The common sources of noise are given below :

(i) Stray electrical and magnetic fields present in the neighbourhood of the instruments produce extraneous signals which tend to distort the original signal. The effects of these stray fields can be minimized by adequate shielding or relocation of the components of the instruments.

(ii) Mechanical shocks and vibrations are another source of trouble. Their effect can be eliminated by proper mounting devices.

(iii) Resistors generate thermal agitation noise due to thermal motion of the electrons in their interior. The effect increases with increased temperature of the resistor. This is called Johnson or Thermal noise. The magnitude of this noise voltage is :

$$V = 2\sqrt{kTR\Delta f} \text{ volt} \quad \dots(2'10)$$

where $k = \text{Boltzmann constant} = 1.38 \times 10^{-23} \text{ J/K}$,
 $T = \text{absolute temperature of resistor ; K}$,
 $R = \text{resistance, } \Omega$

and $\Delta f = \text{frequency range over which measurements are being made ; Hz}$.

This noise can assume alarming proportions as explained in Example 2'5.

(iv) The noise may also originate from use of vacuum tubes.

It is desirable to keep the signal to noise ratio (S/N ratio) as high as possible so as to accurately measure the wanted signal. In amplifying system, the signal to noise ratio sets an upper limit to amplification. Thus the wanted signal cannot be amplified to the extent as we want it to be on account of the fact that noise is also amplified by the same ratio as the original signal. Another handicap is that the signal has to read against the background of amplified noise.

Example 2'5. Pressure is measured by strain gauges. One strain gauge is active and the other is dummy. These strain gauges form the opposite arms of a Wheatstone bridge. The other two arms are formed by equal resistances of 120Ω each at 300K . The frequency bandwidth is $100,000\text{ Hz}$. The output of the bridge is a voltage signal.

(i) When a pressure of 7000 kN/m^2 is applied the output voltage is 0.12 mV . Find the ratio of the output (signal) voltage to the noise voltage generated by the resistors.

(ii) Find the ratio of output (signal) voltage to the noise voltage if the applied pressure is 7 kN/m^2 .

The Boltzmann constant is $1.38 \times 10^{-23} \text{ J/K}$.

Comment upon the results.

Solution: (i) From Eqn. 2'10, the noise voltage is :

$$V = 2\sqrt{kTR\Delta f} = 2\sqrt{1.38 \times 10^{-23} \times 300 \times 120 \times 100000} \text{ volt} = 0.466 \mu\text{V}.$$

$$\text{Signal to noise (S/N) ratio} = \frac{0.12 \times 10^{-3}}{0.446 \times 10^{-6}} = 269.$$

In this case the noise voltage is negligible as compared with the signal voltage and therefore S/N ratio is high. Thus the interference due to noise is insignificant and hence does not distort the signal and the result is unaffected.

(ii) Assume a linear relationship between the output voltage of the bridge and the applied pressure.

\therefore Output (signal) voltage, when the applied pressure is 7 k N/m^2 , is :

$$= \frac{7 \times 10^3}{7000 \times 10^3} \times 0.12 \times 10^{-3} \text{ volt} = 0.12 \times 10^{-6} = 0.12 \mu\text{V}$$

$$\therefore \text{Signal to noise (S/N) ratio} = \frac{0.12 \times 10^{-6}}{0.446 \times 10^{-6}} = 0.27.$$

This indicates that the noise has a magnitude which is about 3.75 times that of signal and hence the signal will be completely lost in the noise.

2.13. Accuracy and Precision

In ordinary usage, the distinction between words "Accuracy" and "Precision" is usually very vague. In fact even the dictionaries invariably link the definition of one with the other. But as far as field of measurements is concerned, there is a big difference between the two terms as they have sharp differences in meanings. In the field of measurements, the two terms may be defined as:

Accuracy. It is the closeness with which an instrument reading approaches the true value of the quantity being measured: Thus accuracy of a measurement means conformity to truth.

Precision. It is a measure of the reproducibility of the measurements, *i.e.* given a fixed value of a quantity, precision is a measure of the degree of agreement within a group of measurements. The term 'Precise' means clearly or sharply defined. As an example of the difference in meaning of the two terms, suppose that we have an ammeter which possesses high degree of precision by virtue of its clearly legible, finely divided, distinct scale and a knife edge pointer with mirror arrangements to remove parallax. Let us say that its readings can be taken to 1/100 of an ampere. At the same time, its zero adjustment is wrong. Now every time we take a reading, the ammeter is as precise as ever, we can take readings down to 1/100 of an ampere, and the readings are consistent and "clearly defined". However, the readings taken with this ammeter are not accurate, since they do not confirm to truth on account of its faulty zero adjustment.

Let us cite another example. Consider the measurement of a known voltage of 100 V with a meter. Five readings are taken, and the indicated values are 104, 103, 105, 103 and 105 V. From these values it is seen that the instrument cannot be depended on for an accuracy better than 5% (5 V in this case), while a precision of $\pm 1\%$ is indicated since the maximum deviation from the mean reading of 104 V is only 1.0 V. Thus we find that the instrument can be calibrated so that it could be used to read ± 1 V dependably. This example illustrates that accuracy can be improved upon but not the precision of the instrument by calibration. Another point which is evident from above is that although the readings are close together they have a small scatter (or dispersion) and thus have a high degree of precision but the results are far from accurate. The precision of an instrument is usually dependent upon many factors and requires many sophisticated techniques of analysis.

Thus we say that a set of readings shows precision if the results agree among themselves. Agreement, however, is no guarantee, as there may be some systematic disturbing effect that causes all the values to be in error.

2.14 Indications of Precision

Precision is composed of two characteristics:

- (i) Conformity and (ii) Number of significant figures.

Precision is used in measurements to describe the *consistency or the reproducibility* of results. A quantity called **precision index** defined in chapter 3 describes the spread, or dispersion of repeated result about some central value. High precision means a tight cluster of repeated results while low precision indicates a broad scattering of results. But this may not lead us to the misconception that high precision indicates high degree of accuracy since all the repetitions in result may be biased in the same way by some systematic effect that produces same deviation of results from the true value. For example, a spring scale used with a spring designed for a different spring scale may repeatedly show the same value of weight. Thus the readings may display exceptional agreement between themselves, but they all would be inaccurate values of weight since use of a wrong spring introduces a systematic shift of all readings.

We may well cite another example to illustrate another aspect of precision.

Consider, for example, that a resistor whose true resistance is 1,385,692 Ω , is being measured by an ohmmeter. The ohmmeter consistently and repeatedly indicates the true value. But the observer cannot read this value from the scale. The observer's estimates from the scale reading consistently

yield a value of 1.4 megohm (1.4 M Ω). This is as close to the true value as he can read the scale by estimation. Although there are no deviations from the observed value, the error created by the limitation of the scale reading is a precision error.

The above example illustrates that *conformity* is necessary, but not sufficient condition for precision because of lack of *significant figures* obtained. Similarly, *precision* is a necessary, but not sufficient condition for *accuracy*.

In critical work, good practice requires an independent set of measurements, using different instruments or different measurement techniques which are not subject to the same systematic errors. Where this is not possible, the experimenter must take steps that insure proper functioning of instruments and to discover and eliminate any systematic disturbing factor. Calibration against a known standard may be resorted to in order to achieve the above purpose.

2.15. Significant Figures

An indication of the precision of the measurement is obtained from the number of significant figures in which it is expressed. Significant figures convey actual information regarding the magnitude and the measurement precision of a quantity. The more the significant figures, the greater the precision of measurement.

Let us take an example. If a voltage is specified as 256 V its value should be taken as closer to 256 V than to either 257 V or 255 V. If the value of voltage is described as 256.0 V it means that the voltage is closer to 256.0 V than it is to 256.1 V or 255.9 V. In 256 there are three significant figures while in 256.0 there are four. The latter, with more significant figures, expresses a measurement of greater precision than the former.

Frequently large numbers with zeros before a decimal point are used for approximate populations or amounts of money. For example the population of a city is reported as 490,000. This may due to misconception, imply that the true value lies between 489,999 and 490,001, which is six significant figures. But in fact, what is meant, however, is that the population is closer to 4.0,000 than to 480,000 or 500,000. Since the population can be reported only to two significant figures. How else large numbers be expressed? A more technically correct notation uses powers of ten like 4.9×10^5 or 4.9×10^5 . This indicates that the population figure is only accurate to two significant figures. Thus reference to population of a city as 3,000,000 would be interpreted automatically as an approximate number while reference to velocity of light as 300,000,000 metre per second creates no confusion to a person with a technical background. Uncertainty caused by zeros to the left of decimal point is therefore usually resolved by scientific notation using powers of ten.

Example 2.6. State the number of significant figures in each of the following numbers :

(a) 302 A (b) 302.10 V (c) 0.00030 Ω (d) 0.0000300 k Ω (e) 5.01×10^4 (f) 50100.

Solution : (a) The number is 302. This means that it is more close to 302 than to either 301 or 303. Thus this number has 3 significant figures.

(b) The number involved is 302.10. Therefore it is more close to 302.10 than either to 301.09 or to 302.11. Thus it has 5 significant figures.

(c) The number is 0.00030. This means that it is more close to 0.00030 than either to 0.00029 or 0.00031. Thus it has 5 significant figures.

(d) The resistance is 0.00003 M Ω . This can be written as 30 Ω . Thus it is more close to 30 than to either 29 or 31. Therefore it has 2 significant figures. The zeros to the left of 3 are due to large size of unit.

(e) The number under consideration is 5.01×10^4 . Hence it is more close to 5.01×10^4 than to either 5.00×10^4 or 5.02×10^4 . Thus it has 3 significant figures.

(f) The number is 50100. This is a large number and a situation may arise that causes uncertainty. Strictly 50,100 means that the number is more close to 50,100 than either to 50,099 or 50,101. This means that the number has 5 significant figures. However, if this number is population of a town it could be written as 5.01×10^4 . Under this situation we can say that the population is close to 5.01×10^4 than to either 5.00×10^4 or 5.02×10^4 . This means that number has 3 significant figures.

2.16. Range of Doubt or Possible Errors and Doubtful Figures

It is customary in measurement work to record the result with all the digits of which we are sure, and final digit which is believed to be nearest to the true value. This usually implies that the reported result is good to ± 1 in the digit in the last place *i.e.*, the digit in doubt. For example, in reading a wattmeter the power may be read as 22.6 W. This simply indicates that the power read by the observer to the best estimation is closer to 22.6 W, than to either 22.5 W or 22.7 W. Another way of expressing this result indicates the 'range of doubt or possible error'. The way to express doubt regarding the last place, the digit in doubt is put in italics form. For example 22.6 W indicates that we know the power to better than unit and that we are not sure about the tenths but all the same believe the value of digit in the tenths place is close to 6. A similar but definite method is to express the above power as 22.6 ± 0.05 W indicating that the power lies between 22.55 W and 22.65 W giving the range of doubt or possible error as 0.1 W.

When a number of independent measurements are taken in order to obtain the best measured value, the result is usually expressed as arithmetic mean of all readings. The range of doubt or possible error is the largest deviation from the mean.

Example 2.7. A set of independent current measurements were recorded as 10.03, 10.10, 10.11 and 10.08 A. Calculate (a) the average current, and (b) the range of error.

Solution :

$$(a) \text{ Average current } I_{av} = \frac{I_1 + I_2 + I_3 + I_4}{4} = \frac{10.03 + 10.10 + 10.11 + 10.08}{4} = 10.08 \text{ A.}$$

$$(b) \text{ Maximum value of current } I_{max} = 10.11 \text{ A}$$

$$\text{Range} = I_{max} - I_{av} = 10.11 - 10.08 = 0.03 \text{ A.}$$

$$\text{Minimum value of length } I_{min} = 10.03 \text{ A.}$$

$$I_{av} - I_{min} = 10.08 - 10.03 = 0.05 \text{ A.}$$

$$\text{Therefore average range of error is} = \frac{0.03 + 0.05}{2} = \pm 0.04 \text{ A.}$$

The number of significant figures in a quantity is one measure of precision, though not as definite as a percentage statement. Suppose the range of doubt in a 101 Ω resistor (the value has 3 significant figures) is 1 Ω . This means that the value lies between 100.5 Ω and 101.5 Ω . This range of doubt in percentage terms is 1 percent. The same range of doubt of 1 Ω in a 999 Ω resistor (again the value has 3 significant figures) creates a percentage range of doubt as only 0.1 per cent.

Therefore three significant figures may cover a percentage range of doubt of 0.1 to 1 per cent and hence is indefinite as a measure of precision.

Superfluous figures are sometimes allowed to accumulate in ordinary arithmetic processes of addition, subtraction, multiplication and division. In these computational processes, the doubtful figures are written in italics, and also figures that result from their use in the processes and are thereby placed in doubt. There is another thing that is obvious it is useless to give more than one doubtful figure. To illustrate the point we should not put the result 117.6 since the figure in the units place (*i.e.* 7) is in doubt, and therefore, it is useless to put a figure in tenths place. The correct way to express the above result is 117.

To illustrate further, two examples are given below :

Example 2.8. Three resistors have values of 72.3, 2.73 and 0.612 Ω respectively with an uncertainty of one unit in the last figure in each case. Find the sum of three connected in series.

Solution :

Since the three resistances are in series, their sum is : $R = R_1 + R_2 + R_3$

$$\begin{array}{r}
 \text{Now} \quad R_1 = 72.3 \, \Omega. \\
 \quad \quad R_2 = 2.73 \, \Omega. \\
 \quad \quad R_3 = 0.612 \, \Omega. \\
 \hline
 \quad \quad R = 75.642 \, \Omega.
 \end{array}$$

The result cannot be expressed as $65.642 \, \Omega$ as even the figure in the tenth place *i.e.*, 6 is in doubt. Therefore the resultant resistance is $65.6 \, \Omega$ with 6 as first doubtful figure.

Example 2.9. The voltage and current recorded in a d.c. circuit are respectively $12.16 \, \text{V}$ and $1.34 \, \text{A}$. Calculate the power:

$$\text{Solution : Power} = 12.16 \times 1.34 \, \text{W.}$$

Multiply by long hand, we have :

$$\begin{array}{r}
 12.16 \\
 1.34 \\
 \hline
 4864 \\
 3648 \\
 1216 \\
 \hline
 16.2944
 \end{array}$$

The power is expressed as $16.2 \, \text{W}$ as 2 is the first doubtful figure. It would obviously be absurd to write the answer with the entire product obtained.

When two or more measurements with different degrees of accuracy are added, the result is only as accurate as the least accurate measurement. This is illustrated by the following example :

Example 2.10. Two resistors R_1 and R_2 are connected in series with $R_1 = 28.7 \, \Omega$ and $R_2 = 3.624 \, \Omega$. Calculate the total resistance to the appropriate number of significant figures.

Solution :

$$R_1 = 28.7 \, \Omega \quad (\text{three significant figures})$$

$$R_2 = 3.624 \, \Omega \quad (\text{four significant figures})$$

$$\text{Total resistance } R = R_1 + R_2$$

$$= 32.324 \, \Omega \quad (\text{five significant figures})$$

$$= 32.3 \, \Omega \quad (\text{three significant figures})$$

This is done because one of the resistances is accurate only to three significant figures (or tenth of an ohm in this case) and therefore the result should also be reduced to three significant figures (or the nearest tenth of an ohm in this case) and hence the value $32.3 \, \Omega$.

The number of significant figures in multiplication may increase rapidly, but only the appropriate figures are retained in the answer as is illustrated by the following example.

Example 2.11. In calculating voltage drop, a current of $4.37 \, \text{A}$ is recorded in a resistance of $31.27 \, \Omega$. Calculate the voltage drop across the resistor to the appropriate number of significant figures.

Solution :

$$\text{Current } I = 4.37 \, \text{A} \quad (\text{three significant figures})$$

$$\text{Resistance } R = 31.27 \, \Omega \quad (\text{four significant figures})$$

$$\text{Voltage drop } E = IR = 4.37 \times 31.27 = 136.6499 \, \text{V} \\ (\text{seven significant figures})$$

Since there are three significant figures involved in the multiplication, the answer can be written only to a maximum of three significant figures.

$$\therefore E = 137 \text{ V.}$$

2.17. Static Sensitivity

The static sensitivity of an instrument or an instrumentation system is the ratio of the magnitude of the output signal or response to the magnitude of input signal or the quantity being measured. Its units are millimetre per micro-ampere, counts per volt etc. depending upon the type of input and output.

Sometimes the static sensitivity is expressed as the ratio of the magnitude of the measured quantity to the magnitude of the response. Thus the sensitivity expressed this way has the units of micro-ampere per millimetre or volt per count etc. as the case may be depending upon nature of input and output. Thus it is reciprocal of the sensitivity as defined above. This ratio is defined as **deflection factor** or **inverse sensitivity**. Many manufacturers define the sensitivity of their instruments in terms of inverse sensitivity and still call it sensitivity.

When a calibration curve is linear as in Fig. 2.3 (a) the sensitivity of the instrument can be defined as in slope of the calibration curve. For this case the sensitivity is constant over the entire range of the instrument. However, if the curve is not nominally a straight line the sensitivity varies with the input as in Fig. 2.3 (b). The sensitivity in this case varies

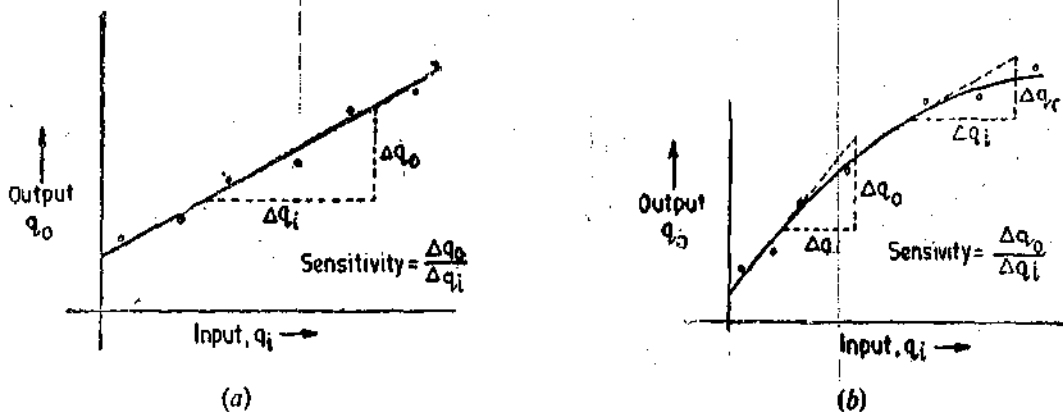

Fig. 2.3. Definition of sensitivity.

In general, the static sensitivity at the operating point is defined as :

$$\text{Static sensitivity} = \frac{\text{infinitesimal change in output}}{\text{infinitesimal change in input}} = \frac{\Delta q_o}{\Delta q_i} \quad \dots(2.11)$$

Similarly,

$$\text{Inverse sensitivity or deflection factor} = \frac{\Delta q_i}{\Delta q_o} \quad \dots(2.12)$$

The sensitivity of an instrument should be high and therefore the instrument should not have a range greatly exceeding the value to be measured. However, some margin should be kept for any accidental overloads.

Example 2.12. A Wheatstone bridge requires a change of 7Ω in the unknown arm of the bridge to produce a change in deflection of 3 mm of the galvanometer. Determine the sensitivity. Also determine the deflection factor

Solution :

$$\text{Sensitivity} = \frac{\text{magnitude of output response}}{\text{magnitude of input}} = \frac{3.000 \text{ mm}}{7.000 \Omega} = 0.429 \text{ mm}/\Omega$$

$$\text{Inverse sensitivity or scale factor} = \frac{\text{magnitude of input}}{\text{magnitude of output response}} = \frac{700 \Omega}{3000 \text{ mm}} \\ = 2.33 \Omega/\text{mm}.$$

Example 2'13. A mercury thermometer has a capillary tube of 0.25 mm diameter. If the bulb is made of a zero expansion material what volume must it have if a sensitivity of 2.5 mm/°C is desired? Assume that the operating temperature is 20°C and the co-efficient of volumetric expansion of mercury is $0.181 \times 10^{-3}/^\circ\text{C}$.

Solution : Let :

L_c = length of capillary tube which would be occupied by mercury contained in the bulb when it is not heated ; mm,

$L_c + \Delta L_c$ = length of capillary tube which would be occupied by mercury contained in the bulb when heated ; mm,

A_c = area of capillary tube ; mm²,

α_v = co-efficient of volumetric expansion ; mm³/mm³·°C,

and ΔT = change in temperature ; °C.

It should be noted that there will be only a change in length of mercury column since it is given that the bulb has a zero expansion material and hence there will be no changes in its area and length. This is true of capillary tube as well.

$$\text{Sensitivity } S = \frac{\Delta q_n}{\Delta q_i} = \frac{(L_c + \Delta L_c) - L_c}{\Delta T} = \frac{\Delta L_c}{\Delta T} = 2.5 \text{ mm}/^\circ\text{C}.$$

$$\text{Now } A_c (L_c + \Delta L_c) = A_c (L_c + \alpha_v L_c \Delta T)$$

∴ Length of capillary tube

$$L_c = \frac{1}{\alpha_v} \cdot \frac{\Delta L_c}{\Delta T} = \frac{1}{0.181 \times 10^{-3}} \times 2.5 = 13.8 \times 10^3 \text{ mm} = 13.8 \text{ m}.$$

$$\text{Hence area of bulb } A_b = A_c L_c = \frac{\pi}{4} (0.25)^2 \times 13.8 \times 10^3 = 680 \text{ mm}^3.$$

2'18. Instrument Efficiency

The efficiency of any instrument is defined as the ratio of the measured quantity at full scale to the power taken by the instrument at full scale. The introduction of an instrument used for measurements in a circuit should not affect the existing conditions in the circuit. The efficiency of an instrument should be as high as possible, as the higher the efficiency the lesser the effect the instrument has upon the circuit under measurement.

Let us consider the case of voltmeter for which we have :

R_m = resistance of meter,

and E_{fs} = full scale voltage reading.

∴ Current at full scale reading

$$I_{fs} = \frac{E_{fs}}{R_m} \quad \dots(2'13)$$

Power consumed at full scale reading

$$P_{fs} = E_{fs} I_{fs} = \frac{E_{fs}^2}{R_m}$$

∴ Efficiency of instrument

$$\eta = \frac{E_{fs}}{P_{fs}} = \frac{E_{fs}}{E_{fs}^2/R_m} = \frac{R_m}{E_{fs}} \quad (2'14)$$

Hence the efficiency of a voltmeter is the ratio of resistance of the meter to its voltage at full scale and is expressed in ohm per volt.

From Eqns. 2.13 and 2.14 it is clear that in order that a voltmeter has a high efficiency and it draws smaller values of current, the resistance of the voltmeter should be high. High efficiency voltmeters are a prerequisite for measurements especially in electronic circuits where the current and the power are small.

Example 2.14. A 5.0 ampere ammeter has a resistance of 0.01 Ω . Determine the efficiency of the instrument.

Solution : Full scale reading of ammeter $I_{fs} = 5$ A.

Power consumed at full scale $P_{fs} = I_{fs}^2 R_m = (5)^2 \times (0.01) = 0.25$ W

Efficiency of ammeter $= \frac{I_{fs}}{P_{fs}} = \frac{5}{0.25} = 20$ A/W.

2.19. Index Scale and Index Number

An analogue instrument may be thought as a mechanism which has an input of the quantity being measured and an output which is usually displacement of a pointer over a scale. Divisions are marked on a scale, the set of marks or divisions form an **index scale** and the divisions moved is the **index reading**.

As far as digital instruments are concerned same theory may be applied. In a spatial encoder the quantity being measured produces a displacement of the mechanism. This displacement is converted into a digital number.

Example 2.15. An ammeter has 100 divisions on its index scale. The instrument is provided with range multiplier switches of 1, 10 and 100. Find the range of the instrument and the scale range.

Solution : Highest multiplier switch = 100 times.

\therefore Range of instrument = 100×100 mA = 10×10^3 mA = 10 A

Index range = 0 - 100.

2.20. Linearity. One of the best characteristics of an instrument or a measurement system is considered to be linearity, that is, the output is linearly proportional to the input. Most of the systems require a linear behaviour as it is desirable. This is because the conversion from a scale reading to the corresponding measured value of input quantity is most convenient if one merely has to multiply by a fixed constant rather than consult a non-linear calibration curve or compute from non-linear calibration equations. Also when the instrument is part of a large data or control system, linear behaviour of the part often simplifies the design and analysis of the whole system. Therefore relationships to the degree of straight line relationship (*i.e.*, linearity) are common.

If for an instrument calibration curve (relating output to input) is not a straight line, it should not be concluded that the instrument is inaccurate. This is a misconception, a non-linear behaviour does not essentially lead to inaccuracy. Such an instrument may be highly accurate as ever.

However, most of the time it is necessary that measurement system components should have linear characteristics. For example, the resistance used in a potentiometer should vary very linearly with displacement of the sliding contact in order that the displacement is directly proportional to the sliding contact voltage. Any departure from linearity would result in error in the read out system.

Fig 2.4 shows the variation of resistance with displacement of sliding contact. In case the resistance to the sliding contact is proportional to the displacement, all the values of resistance would lie on a straight line (firm line as shown in Fig. 2.4). However, in practice it may not always be possible to have linearity, *i.e.*, linear variation. Suppose

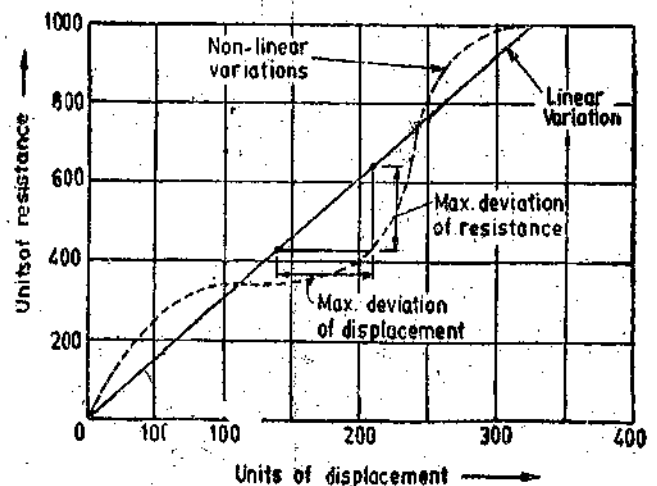

Fig. 2.4. Linearity and non-linearity.

that the resistance varies as shown by a curved dotted line, in that case there is deviation from linearity. This deviation from linearity may be expressed by a term "Percent Linearity".

Percent linearity may be defined as

$$\text{Percent linearity} = \left(\frac{\text{maximum resistance deviation}}{\text{full scale deviation}} \right) \times 100 \quad \dots (2.15)$$

for this particular case. In general percent linearity is :

$$= \left(\frac{\text{maximum displacement deviation}}{\text{full scale deviation}} \right) \times 100 \quad \dots (2.16)$$

It is desirable to keep the percent linearity as small as possible as it would, in that case, result in small errors in the read out system. For example if a self-balancing potentiometer has a percent linearity of 0.1 per cent, its accuracy would be 1 part in 1000. With a 1000 count digital encoder connected to the shaft of the potentiometer, it would produce an error of 1 count in 1000 counts.

Example 2.16. A 10,000 Ω variable resistance has a linearity of 0.1% and the movement of contact arm is 320°. (a) Determine the maximum position deviation in degrees and the resistance deviation in ohm. (b) If this instrument is to be used as a potentiometer with a linear scale of 0 to 1.6 V, determine the maximum voltage error.

Solution : (a) From Eqn. 2.16,

$$\begin{aligned} \text{Maximum displacement deviation} &= \frac{\text{percent linearity} \times \text{full scale deviation}}{100} \\ &= \frac{0.1 \times 320}{100} = 0.32^\circ \end{aligned}$$

$$\text{Similarly, maximum resistance displacement} = \frac{0.1 \times 10,000}{100} = 10 \Omega$$

(b) A displacement 320° corresponds to 1.6 V and therefore 0.32° corresponds to a voltage of :

$$\frac{0.32}{320} \times 1.6 = 1.6 \times 10^{-3} \text{ V}$$

$$\therefore \text{Maximum voltage error} = 1.6 \times 10^{-3} \text{ V} = 1.6 \text{ mV.}$$

2.21. Hysteresis. Hysteresis effects show up in any physical, chemical or electrical phenomenon. Hysteresis is a phenomenon which depicts different output effects when loading and unloading whether it is a mechanical system or an electrical system and for that matter any system. Hysteresis is non-incidence of loading and unloading curves. Hysteresis, in a system, arises due to the fact that all the energy put into the stressed parts when loading is not recoverable upon unloading. This is because the second law of thermodynamics rules out any perfectly reversible process in the world.

Hysteresis effects are there in electrical phenomena. One of the examples is the relationship between output voltage and field current in a d.c. generator. This is due to magnetic hysteresis. This curve is of the shape shown in Fig. 2.5 (a).

In mechanical parts of a system, there may be internal friction, external sliding friction and coulomb friction. There may be a free play or looseness in the mechanism. In a given instrument a number of causes, such as listed above, combine to give an overall effect which may result in output-input relationship such as shown in Fig. 2.5 (b).

2.22. Threshold. It is clear from above that if the instrument input is increased very gradually from zero there will be some minimum value below which no output change can be detected. This

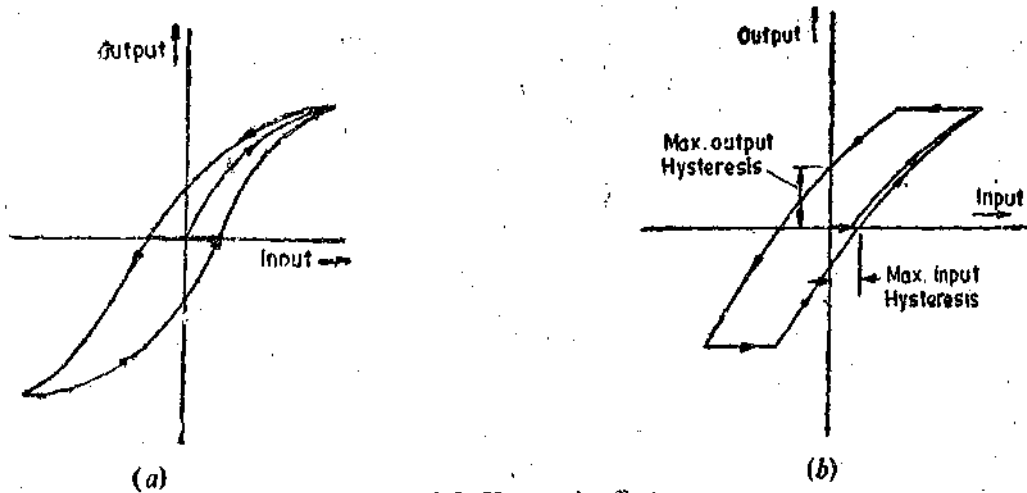

Fig. 2.5. Hysteresis effects.

minimum value defines the **threshold** of the instrument. In specifying threshold, the first detectible output change is often described as being any "noticeable measurable change".

2.23. Dead Time. Dead time is defined as the time required by a measurement system to begin to respond to a change in the measurand. Fig. 2.6 shows the measured quantity and its value as indicated by an instrument. Dead time, in fact, is the time before the instrument begins to respond after the measured quantity has been changed.

2.24. Dead Zone. It is defined as the largest change of input quantity for which there is no output of the instrument (Fig. 2.6). For example the input applied to the instrument may not be sufficient to overcome the friction and will, in that case, not move at all. It will only move when the input is such that it produces a driving force which can overcome friction forces. As stated in Art. 2.20 other factors which produce dead zone are backlash or hysteresis in the instrument.

The term "dead zone" is sometimes used interchangeably with term hysteresis. However, it may be defined as the total range of input values possible for a given output and may thus be numerically twice the hysteresis defined in Fig. 2.5 (b).

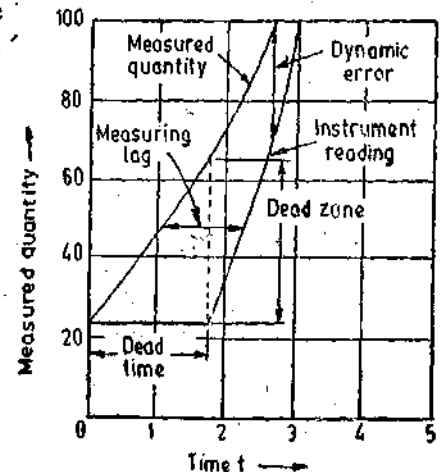

Fig. 2.6. Dead time and dead zone.

Example 2.17. The dead zone in a certain pyrometer is 0.125 percent of span. The calibration is 400°C to 1000°C. What temperature change might occur before it is detected.

Solution : Span = 1000 - 400 = 600°C.

$$\therefore \text{Dead zone} = \frac{0.125}{100} \times 600 = 0.75^\circ\text{C}.$$

\therefore A change of 0.75°C must occur before it is detected.

2.25. Resolution or Discrimination

If the input is slowly increased from some arbitrary (non-zero) input value, it will again be found that output does not change at all until a certain increment is exceeded. This increment is called **resolution** or **discrimination** of the instrument. Thus the smallest increment in input (the quantity being measured) which can be detected with certainty by an instrument is its **resolution** or **discrimination**. So **resolution** defines the smallest measurable input change while the **threshold** defines the smallest measurable input.

Example 2.18. A moving coil voltmeter has a uniform scale with 100 divisions, the full scale reading is 200 V and 1/10 of a scale division can be estimated with a fair degree of certainty. Determine the resolution of the instrument in volt.

Solution : $1 \text{ scale division} = \frac{200}{100} = 2 \text{ V}$

Resolution = $\frac{1}{10} \text{ scale division} = \frac{1}{10} \times 2 = 0.2 \text{ V}$.

Example 2.19. A digital voltmeter has a read-out range from 0 to 9,999 counts. Determine the resolution of the instrument in volt when the full scale reading is 9.999 V.

Solution : The resolution of this instrument is 1 or 1 count in 9,999.

$\therefore \text{Resolution} = \frac{1}{9999} \text{ count} = \frac{1}{9999} \times 9.999 \text{ volt} = 10^{-3} \text{ V} = 1 \text{ mV}$.

2.26. Loading Effects. The ideal situation in a measurement system is that when an element used for any purpose may be for signal sensing, conditioning, transmission or detection is introduced into the system, the original signal should remain unmolested. This means that the original signal should not be distorted in any form by introduction of any element in the measurement system. However, under practical conditions it has been found that introduction of any element in a system results, invariably, in extraction of energy from the system thereby distorting the original signal. This distortion may take the form of attenuation (reduction in magnitude), waveform distortion, phase shift and many a time all these undesirable features put together. This makes ideal measurements impossible. The incapability of the system to faithfully measure, record, or control the input signal (measurand) in undistorted form is called the loading effect.

It may be recalled that a measurement system consists of three distinct stages :

- (i) Detector-Transducer stage,
- (ii) Signal conditioning stage (including signal transmission stage),
- and (iii) Signal presentation stage.

The loading effects do not occur only in the first stage but may occur in any of the two subsequent stages while the first stage detector transducer loads the input signal, the second stage loads the first stage, and finally the third stage loads the second stage. In fact, the loading problem may be carried right down to the basic elements themselves.

2.27. Loading Effects due to Shunt Connected Instruments

In measurement systems, voltage measuring, displaying and recording instruments like voltmeters, oscilloscopes and strip chart recorders are connected across the circuit in shunt (parallel) with the circuit.

Consider a network consisting of linear bilateral impedances and generators with output terminals. *A* and *B* as shown in Fig. 2.7. This is a blackbox with a Thevenin generator of voltage E_0 and an output impedance Z_0 in series. Supposing we are primarily concerned with the voltage of the output signal. Let E_0 be the open circuit voltage *i.e.* the voltage that appears across the terminals *A* and *B* when the load (or any other measuring or recording device) which is a voltmeter in this case is not connected to the terminals.

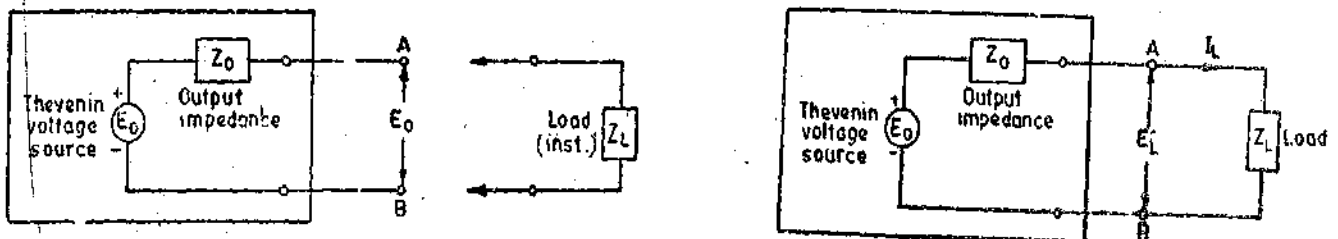

Fig. 2.7. Voltage source and shunt connected instrument.

Ideally, when the load is connected across terminals *A* and *B* the output voltage should remain

the same. However, the load impedance is not infinite and therefore when a voltmeter with an input impedance Z_L is connected across A and B , a current I_L flows. This causes a voltage drop $I_L Z_0$.

∴ Output voltage under loaded conditions is :

$$E_L = E_0 - I_L Z_0 = I_L Z_L \quad \text{or} \quad E_0 = I_L (Z_L + Z_0)$$

∴ Ratio of actual voltage appearing across the load (when the instrument is connected) to the voltage under no load conditions (ideal in this case) is :

$$\frac{E_L}{E_0} = \frac{I_L Z_L}{I_L (Z_L + Z_0)} = \frac{1}{1 + Z_0/Z_L} \quad \dots(2'17)$$

∴ Actual voltage measured, $E_L = \frac{E_0}{1 + Z_0/Z_L}$...(2'18)

Thus the voltage which is measured is modified both in phase and magnitude. This means that the original voltage signal is distorted on account of connection of measuring instrument across it.

It is clear from Eqn. 2'18 that in order that the original signal E_0 should remain undistorted the value of input impedance of the instrument, Z_L , should be infinite (or the value of output impedance of the source, Z_0 should be equal to zero which is not attained in practice).

In order to obtain as less distortion as possible the value of Z_L , the input impedance of instrument, should be very high as compared with Z_0 , the output impedance of the source.

To illustrate the loading effects of shunt devices a few examples are given below. First we will give examples connected with d.c. and then go over to a.c. applications.

Example 2'20. A multimeter having a sensitivity of $2,000 \Omega/V$ is used to measure the voltage across a circuit having an output resistance of $10 \text{ k}\Omega$. The open circuit voltage of the circuit is 6 V . Find the reading of the multimeter when it is set to its 10 V scale. Find the percentage error.

Solution : Input impedance of voltmeter $Z_L = 20,000 \times 10 \Omega = 20 \text{ k}\Omega$

Output impedance of circuit $Z_0 = 10 \text{ k}\Omega$.

Open circuit voltage of circuit under measurement $E_0 = 6 \text{ V}$.

From Eqn. 6'18, reading of voltmeter is

$$E_L = \frac{E_0}{1 + Z_0/Z_L} = \frac{6}{1 + 10/20} = 4 \text{ V}$$

∴ Percentage error in voltage reading $\frac{4-6}{6} \times 100 = -33\%$ or 33% low.

The loading problem given in Example 2'20 is typical of cases where a common type of voltmeter such as a multimeter whose input impedance is comparable with that of the impedance of the circuit under test is used for measuring voltage. Thus voltmeters having output impedance comparable to that of circuit under test should not be used as they seriously modify the value of test voltages. Such types of voltmeters are unsuitable for communication and electronic circuits where the impedance levels are high but they can be used for low impedance circuits giving a good accuracy.

If we wish to achieve 99% accuracy in voltage measurement, the input resistance of the voltmeter should be greater 100 times the output resistance. For an accuracy of 95% the input resistance should be atleast 20 times the output resistance.

Example 2'21. Suppose the voltmeter of Example 2'20 is used for measurement of voltage of circuit having an output impedance of 1000Ω and an open circuit voltage of 6 V at its 10 V scale. Find the error in measurement.

Solution : Output resistance of circuit $Z_0 = 1000 \Omega = 1 \text{ k}\Omega$.

$$\text{Reading of voltmeter } E_L = \frac{E_0}{1 + Z_0/Z_L} = \frac{6}{1 + 1/200} = 5.97 \text{ V}$$

$$\text{Percentage Error} = \frac{5.97 - 6}{6} \times 100 = -0.5\% \text{ or } 0.5\% \text{ low.}$$

Thus when the output impedance of source is quite low as compared with input impedance of voltmeter, the error involved in measurements is quite small.

Example 2.22. A 50 V range voltmeter is connected across the terminals A and B of the circuit shown in Fig. 2.8. Find the reading of the voltmeter under open circuit and loaded conditions. Find the accuracy and the loading error. The voltmeter has a resistance of 1000 kΩ.

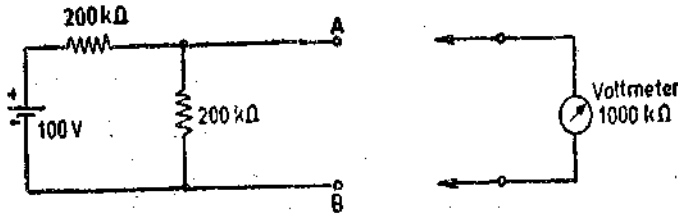

Fig. 2.8

Solution : Let us reduce the circuit to its Thevenin's equivalent circuit. The open circuit voltage, E_0 , appearing across terminals A and B is :

$$E_0 = 100 \times \frac{200}{400} = 50 \text{ V.}$$

The output impedance (resistance in this case) of the source as looking into terminals A and B is :

$$Z_0 = \frac{200 \times 200}{200 + 200} = 100 \text{ k}\Omega.$$

The Thevenin equivalent circuit under loaded conditions is shown in Fig. 2.9.

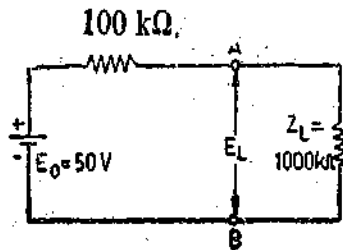

Fig. 2.9

Voltage appearing across terminals A and B under loading conditions is :

$$E_L = \frac{E_0}{1 + Z_0/Z_L} = \frac{50}{1 + 100/1000} = 45.5 \text{ V.}$$

$$\text{Loading error} = \frac{45.5 - 50}{50} = -9\% = 9\% \text{ low.}$$

$$\text{Accuracy} = 100 - \% \text{ loading error} = 100 - 9 = 91\%.$$

Operation with A.C. The analysis of loading effects with a.c. is not so easy. It should be borne in mind that both Z_0 and Z_L are dependent upon frequency. Therefore the indicated voltage will depend upon the frequency of operation. On account of the input capacitance effects of the instrument, the value of input impedance Z_L becomes low at high frequencies with the result the input signal is substantially attenuated at high frequencies.

It is not only the magnitude of the signal that is effected but also its phase. Worst still, as is consequence of the shunt capacitance, the non-sinusoidal signals are distorted in waveform also.

The magnitude of the measured signal becomes substantially smaller with increase in frequency as shown in Fig. 2.10.

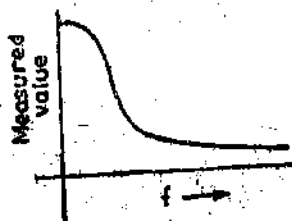

Fig. 2.10. Effect of frequency on output.

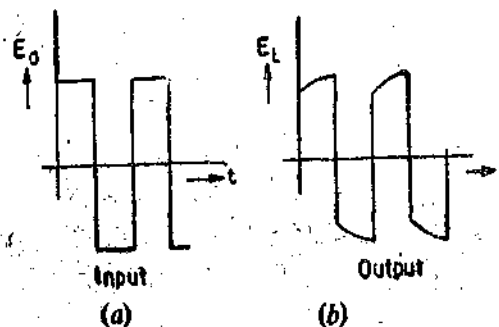

Fig. 2.11. Waveform distortion.

The sharply changing non-sinusoidal waveforms are rounded off because of the finite time it takes to charge a capacitor. This is shown in Fig. 2'11.

The effect of frequency on magnitude and phase shift of a signal is shown in the following example.

Example 2'23. An oscilloscope having an input resistance of $1\text{ M}\Omega$ shunted by 50 pF capacitance is connected across a circuit having an effective output resistance of $10\text{ k}\Omega$. If the open circuit voltage has 1.0 V peak for a 100 kHz sine wave, what will be the voltage indicated on the oscilloscope when the frequency is (i) 100 kHz and (ii) 1 MHz ?

The equivalent circuit for the measurement system is shown in Fig. 2'12.

When frequency = 100 kHz :

The value of capacitive reactance at 100 kHz is

$$X_C = \frac{1}{2\pi fC} = \frac{1}{2\pi \times 100 \times 1000 \times 50 \times 10^{-12}} = 32000\ \Omega$$

The input impedance of the oscilloscope is :

$$Z_L = \frac{R(-jX_C)}{R-jX_C} = \frac{10^6 \times (-j32 \times 10^3)}{10^6 - j32 \times 10^3} \approx -j32 \times 10^3\ \Omega$$

$$= 32 \times 10^3 \angle -90^\circ\ \Omega.$$

The voltage across the load is $E_L = \frac{E_0}{1 + Z_0/Z_L}$

$$= 1.0 \angle 0^\circ \times \frac{1}{1 + \frac{10 \times 10^3 \angle 0^\circ}{32 \times 10^3 \angle -90^\circ}} = \frac{1}{1 + 0.313 \angle 90^\circ} = \frac{1}{1 + j0.313}$$

$$= 0.954 \angle -17.4^\circ\ \text{V (peak)}.$$

This means that the magnitude of voltage indicated by the oscilloscope is 0.954 of its original value.

\therefore The error is $(1 - 0.954) \times 100 = 4.6$ per cent. Also the voltage under loaded conditions lags the voltage under open circuit conditions by an angle of 17.4° .

When frequency = 1 MHz

The value of capacitive reactance of oscilloscope

$$X_C = \frac{1}{2\pi \times 10^6 \times 50 \times 10^{-12}} = 3200\ \Omega$$

The input impedance of oscilloscope is :

$$Z_L = \frac{R(-jX_C)}{R-jX_C} = \frac{10^6(-j3.2 \times 10^3)}{10^6 - j3.2 \times 10^3} \approx -j3200\ \Omega = 32 \times 10^3 \angle -90^\circ\ \Omega$$

\therefore The voltage across the load is $E_L = \frac{E_0}{1 + Z_0/Z_L}$

$$= 1.0 \angle 0^\circ \times \frac{1}{1 + \frac{10 \times 10^3 \angle -0^\circ}{3.2 \times 10^3 \angle -90^\circ}} = \frac{1}{1 + 3.13 \angle 90^\circ}$$

$$= 0.304 \angle -72.3^\circ\ \text{V (peak)}.$$

In this case the measured value is only 0.304 of its original value and the phase shift is 72.3° . Thus the output is considerably attenuated and is less than one third of its original value.

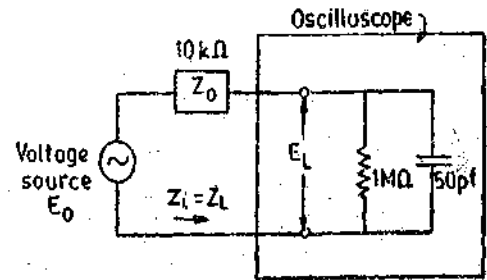
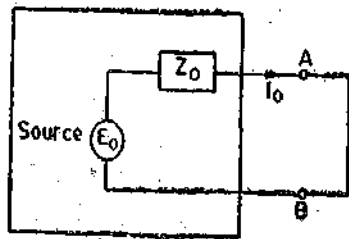

Fig. 2'12

This indicates the effect of distortion of signal on account of increased shunting effect due to increase in frequency.

2.28. Loading Effects due to Series Connected Instruments

Consider a network represented by a voltage source having a voltage E_0 and an output impedance Z_0 . The output terminals are A and B as shown in Fig. 2.13 (a).



(a)

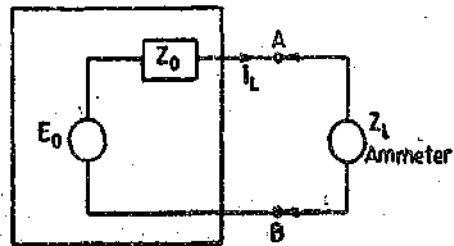

(b)

Fig. 2.13. Loading effect of ammeters.

The value of current flowing between terminals A and B under ideal conditions is I_0 . It is the current that flows when terminals A and B are shorted.

$$I_0 = \frac{E_0}{Z_0} \quad \text{or} \quad E_0 = I_0 Z_0.$$

However, when we actually measure the current, a current measuring device has to be introduced between terminals A and B . It is usually an ammeter. When an ammeter is placed between output terminals, it adds to the impedance of circuit. This added impedance modifies the value of the current.

Suppose Z_L = input impedance of ammeter.

From Fig. 2.13 (b)

$$\text{Measured value of current } I_L = \frac{E_0}{Z_0 + Z_L} = \frac{I_0 Z_0}{Z_0 + Z_L} = \frac{I_0}{1 + Z_L/Z_0} \quad \dots(2.19)$$

In order that the measured value of current, be equal to the actual value of the current, I_0 , the value of $Z_0 \gg Z_L$. This means that the input impedance of the ammeter should be very small as compared with the output impedance of the source.

We can express the relationships of currents under loaded and unloaded conditions in terms of admittances.

From Eqn. 2.19,

$$\begin{aligned} I_L &= \frac{I_0}{1 + Z_L/Z_0} = \frac{I_0 Z_0}{Z_0 + Z_L} \\ &= \frac{I_0/Y_0}{1/Y_0 + 1/Y_L} = \frac{I_0 Y_L}{Y_L + Y_0} \quad \dots(2.20) \end{aligned}$$

$$= \frac{I_0}{1 + Y_0/Y_L} \quad \dots(2.21)$$

In other words the input admittance of the series elements should be very large as compared with the output admittance of the source in order to reduce loading effect.

For achieving 99% accuracy in measurements the output resistance should be at least 100 times the resistance of the meter. In order to have 95% accuracy the output resistance should be at least 20 times the resistance of meter.

Example 2'24. It is desired to measure the value of current in the $500\ \Omega$ resistor as shown in Fig. 2'14 by connecting a $100\ \Omega$ ammeter. Find :

- the actual value of current,
- measured value of current, and
- the percentage error in measurement and the accuracy.

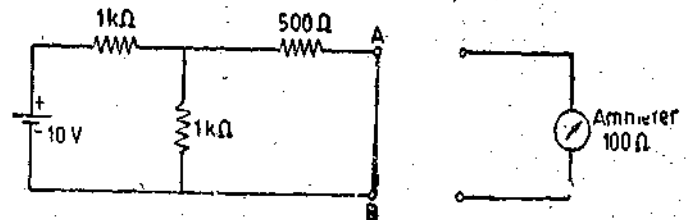

Fig. 2'14

Solution. (a) Let us reduce the actual circuit to an equivalent Thevenin's source.

Open circuit voltage as applying at terminals *A* and *B* is :

$$E_0 = 10 - \frac{10}{2000} \times 1000 = 5\text{ V.}$$

Output impedance of source as looking into terminals *A* and *B* is :

$$Z_0 = \frac{1000 \times 1000}{1000 + 1000} + 500 = 1000\ \Omega.$$

∴ The Thevenin equivalent circuit is as shown in Fig. 2'15.

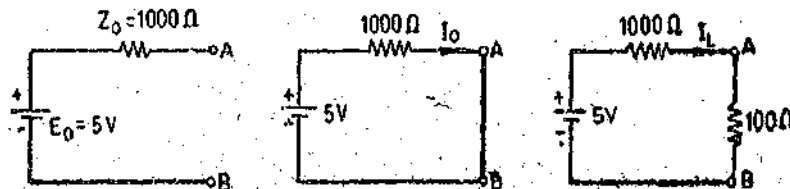

Fig. 2'15

∴ Actual value of current $I_0 = \frac{E_0}{Z_0} = \frac{5}{1000}\text{ A} = 5\text{ mA.}$

(b) When the ammeter is introduced into the circuit the value of current is modified.

∴ Measured value of current $I_L = \frac{E_0}{Z_0 + Z_L} = \frac{5}{1000 + 100}\text{ A} = 4.55\text{ mA.}$

(c) Error = $\frac{4.55 - 5}{5} \times 100 = -9\% = 9\%$ low.

Accuracy of measurement = $100 - 9 = 91\%$.

2'29. Impedance Matching and Maximum Power Transfer

In many applications it is desirable to match the impedance of the input device to the output impedance of the signal source instead of making the impedance of the input device either too high or too low.

Typical cases of impedance matching are those involving applications of waveform generators like pulse generators and radio frequency (RF) generators, which utilize a transmission line to transfer energy from the source to the input device. However, many low frequency cases such as audio amplifiers feeding loudspeakers and other electromechanical transducers require impedance matching for high power transfer.

In measurement systems, many a times we are concerned with the problem of maximum power transfer from the source to the input device. The problem of maximum power transfer is analyzed by first considering the source and also the input device (load) to have only pure resistances. (See Fig. 2'16).

Let E_0 = voltage of the source under no load conditions,

E_L = voltage of the source under loaded conditions,

R_0 = output resistance of the source,

and R_L = input resistance of the load.

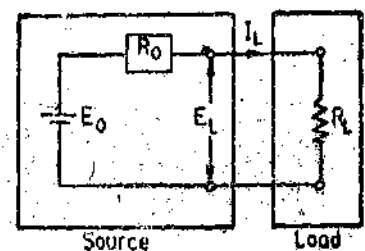

Fig. 2'16

Power transferred to load is $P = \frac{E_L^2}{R_L} = \frac{E_0^2 R_L}{(R_0 + R_L)^2}$... (2'22)

Maximum power transfer takes place when $\frac{dP}{dR_L} = 0$.

Differentiating Eqn. 2'22, and equating it to zero, we get $R_L = R_0$.

Thus in order that maximum power may be drawn from a source (when output impedance of the source is a resistance and also that of the load is a pure resistance) is when the external load resistance matches the internal resistance of the source.

Under conditions of maximum power transfer :

Power delivered to the load is $P_{max} = \frac{E_0^2}{4R_0}$... (2'23)

For A.C. Circuits. The internal impedance (output impedance) of the source and the input impedance (load impedance) may not be pure resistances, but are usually complex impedances.

Let $Z_0 =$ output (internal) impedance of the source $= R_0 + jX_0$,

$Z_L =$ output impedance of the device $= R_L + jX_L$.

For maximum power transfer the impedance of the load should be made equal to the complex conjugate of the Thevenin equivalent impedance of the source.

$Z_L = R_L + jX_L = R_0 - jX_0 = Z_0$... (2'24)

It is clear from Eqn. 2'22, if the no load voltage E_0 , of the source and its output resistance R_0 are given, the power depends upon the magnitude of load resistance R_L . The power approaches zero for either very small or very large values of load resistance R_L . We have derived that for maximum power transference $R_L = R_0$. In other words maximum power can be transferred from a source to a load if the internal resistance of the source or the output resistance of the preceding stage of an instrumentation system is equal to the load resistance or the input resistance of the succeeding source.

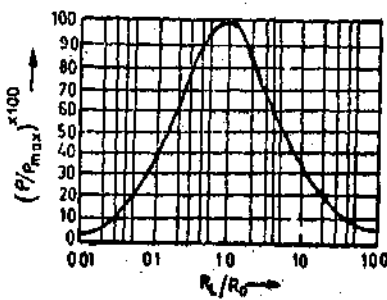

Fig. 2'17. Impedance Matching Characteristics.

It is interesting to note that for maximum power transfer, the efficiency is 50%.

The condition for Impedance matching is not critical. Fig. 2'17 shows the relative amount of power transferred from one system to another for different ratios of R_L/R_0 .

For a $\pm 10\%$ deviation from the correct value of impedance matching, ($R_L/R_0 = 1.1$ or 0.9), the power transfer is still practically 100%. For a 20% change, the power transfer reduces to 99%. Even for a 100% change (ratio $R_L/R_0 = 2$ or 0.5), the power transferred is 89% of the maximum allowable power.

It is very often desirable to change or control the amount of power transferred from one system to another. This can be done by changing the voltage level applied to the load or the current level in the circuit. A variation of the voltage level is difficult with d.c. and generally requires the use of electronic equipment. A control (which is a reduction) of current is relatively simple and is accomplished by inserting a series resistance R_s in the circuit. A disadvantage of this method is considerable loss of power and a very low efficiency. With value of $R_0 = 1 \Omega$, $R_s = 98 \Omega$ and $R_L = 1 \Omega$, the useful power absorbed by the load is 1 W, while the amount of power lost as $I^2 R$ loss in both R_s and R_0 put together is 99 W. Thus the total power furnished by the source is 100 W and that received by the load is 1 W giving an efficiency of 1%.

A very efficient way to control power transferred to one system from another is by pulse modulation of power. In its simplest form this can be done by periodic opening and closing of a switch located between both systems.

Using the notation given in Fig. 2'18; the average power transfer is :

$$P_{av} = \frac{P_{max} t}{T} \quad \dots (2'25)$$

where t = pulse width,
and T = interval between successive pulses.

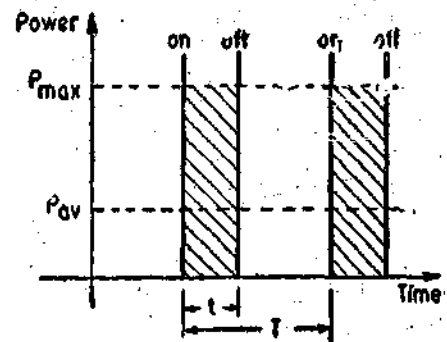

Fig. 2'18. Pulse modulation of Power.

By variation of t between 0 and T , the power can be controlled between 0 and the maximum value of power. The power efficiency is maximum for any value of t . However, it may be noted that this method is restricted to loads which are not affected by the periodic interruption of current.

Power efficiency may not be the foremost consideration in Instrumentation systems. Many other considerations and physical advantages like linearity, efficiency, or avoidance of loading of previous stage may be more important than the maximum power transfer.

Example 2'25. Measurements on a human nerve cell indicate an open circuit voltage of 80 mV, and a current of 5 nA through a 6 MΩ load. What is maximum power available from the cell ?

Solution : Let R_0 be the internal (output) resistance of the cell, I_L the load current and R_L the load resistance.

$$\begin{aligned} \therefore \text{Open circuit voltage of the cell } E_0 &= I_L(R_0 + R_L) \\ \text{or } 80 \times 10^{-3} &= 5 \times 10^{-9}(R_0 + 6 \times 10^6) \end{aligned}$$

Hence, output resistance of cell $R_0 = 10 \times 10^6 \Omega = 10 \text{ M}\Omega$.

$$\begin{aligned} \text{Maximum power available from the cell } P_{max} &= \frac{E_0^2}{4R_0} \\ &= \frac{(80 \times 10^{-3})^2}{4 \times 10 \times 10^6} = 160 \times 10^{-12} \text{ W} = 0.16 \text{ nW}. \end{aligned}$$

Example 2'26. A voltage source has an open circuit voltage of 20 V and has an output impedance of $0.5 + j1 \Omega$. The voltage source is connected to the load through a transmission network having an impedance of $1.5 + j4 \Omega$. At what load will maximum power transfer be realized ? Calculate the maximum power. Also calculate the losses in the voltage source and the transmission network. What is the efficiency under maximum power transfer conditions ?

Solution. The transmission network is connected in series with the voltage source.

\therefore Output impedance of source and the transmission network is :

$$= (0.5 + j1) + (1.5 + j4) = 2 + j5 \Omega.$$

For maximum power transfer the load impedance should be complex conjugate of the above impedance.

\therefore Impedance of load for maximum power transfer i.e. $Z_L = 2 - j5 \Omega$

$$\text{Maximum power } P_{max} = \frac{E_0^2}{4R_0} = \frac{(20)^2}{4 \times 2} = 50 \text{ W}.$$

$$\text{Load current } I_L = \frac{20}{(2 + j5) + (2 - j5)} = 5 \text{ A}$$

$$\text{Power loss in source} = (5)^2 \times 0.5 = 12.5 \text{ W}.$$

$$\text{Power loss in transmission network} = (5)^2 \times 1.5 = 37.5 \text{ W}$$

$$\text{Total losses} = 12.5 + 37.5 = 50 \text{ W}$$

$$\text{Efficiency } \eta = \frac{\text{output}}{\text{output} + \text{losses}} \times 100 = \frac{50}{50 + 50} \times 100 = 50\%.$$

Example 2'27. The output voltage of an audio amplifier is 10 V and 4 V when delivering powers 25 W and 16 W respectively. Find the open circuit voltage and output resistance of the amplifier. What is the maximum power that the amplifier can give ?

Solution : Let R_0 and R_L be the output resistance and load resistance respectively.

$$\text{Load resistance in the first case } R_{L1} = \frac{E_{L1}^2}{P_1} = \frac{(10)^2}{25} = 4 \Omega$$

$$\text{Load resistance in the second case } R_{L2} = \frac{E_{L2}^2}{P_2} = \frac{(4)^2}{16} = 1 \Omega$$

$$\text{Voltage across load } E_L = \frac{E_0 R_L}{R_0 + R_L}$$

$$\therefore \text{ In the first case } 10 = \frac{E_0 \times 4}{R_0 + 4} \quad \text{or} \quad 10 R_0 + 40 = 4 E_0 \quad \dots(i)$$

$$\text{In the second case } 4 = \frac{E_0 \times 1}{R_0 + 1} \quad \text{or} \quad 4 R_0 + 4 = E_0 \quad \dots(ii)$$

From (i) and (ii), we have,

$$\text{Output resistance of amplifier } R_0 = 4 \Omega$$

$$\text{Open circuit voltage of amplifier } E_0 = 20 \text{ V.}$$

The maximum power that a source can give is when its output resistance is equal to load resistance.

\therefore The maximum power output of the amplifier is 25.

2'30. Dynamic Response

When an input is applied to an instrument or a measurement system, the instrument or the system cannot take up its final steady state position immediately. On the other hand, the system goes through a transient state before it finally settles to its final 'steady state' position.

Some measurements are made under conditions that sufficient time is available for the instrument or the measurement system to settle to its final steady state conditions. Under such conditions the study of behaviour of the system under transient state, called 'transient response' is not of much of importance ; only steady state response of the system need be considered.

However, in many areas of measurement system applications it becomes necessary to study the response of the system under both transient as well as steady state conditions. In many applications, the transient response of the system *i.e.*, the way system settles down to its final steady state conditions is more important than the steady state response.

It has been pointed out earlier that the instruments and measuring systems do not respond to the input immediately. This is on account of the presence of energy storage elements in the system. These energy storage elements are electrical inductance and capacitance, mass, fluid and thermal capacitances etc. The systems exhibit a characteristic sluggishness on account of presence of these elements. Furthermore pure delay in time is encountered when a system "waits" for some specific changes and reactions to take place,

Invariably measurement systems, especially in industrial, aerospace, and biological applications are subjected to inputs which are not static but dynamic in nature, *i.e.* the inputs vary with time. Since the input varies from instant to instant, so does the output. The behaviour of the system under such conditions is described by the dynamic response of the system.

The dynamic characteristics of any measurement system are :

- | | |
|-----------------------|--------------------|
| (i) Speed of response | (ii) Lag |
| (iii) Fidelity | (iv) Dynamic error |

The qualities listed on the left side are desirable in a dynamic system while those on the right are undesirable.

Speed of Response. It is the rapidity with which an instrument responds to changes in the measured quantity.

Response Time. It is defined as the time required by instrument or system to settle to its final steady position after the application of the input. For a step function, the response time may be defined as the time taken by the instrument to settle to a specified percentage of the quantity being measured after the application of the input. This percentage may be 90 to 99 percent depending upon the instrument. For portable instruments it is the time taken by the pointer to come to rest within ± 0.3 percent of final scale length while for switch board (panel) type of instruments it is the time taken by the pointer to come to rest within ± 1 percent of its final scale length.

Measuring lag. An instrument does not immediately react to a change. Measuring lag is defined as the delay in the response of an instrument to a change in the measured quantity. This lag is usually quite small but it becomes highly important where high speed measurements are required. In these systems it becomes essential that the time lag be reduced to minimum.

Fidelity. Fidelity of a system is defined as the ability of the system to reproduce the output in the same form as the input. Supposing if a linearly varying quantity is applied to a system and if the output is also a linearly varying quantity the system is said to have 100 percent fidelity. Ideally a system should have 100 percent fidelity and the output appears in the same form as the input and there is no distortion produced by the system. In the definition of fidelity any time lag or phase difference between output and input is not included.

Dynamic Error. It is the difference between the true value of the quantity changing with time and the value indicated by the instrument if no static error is assumed.

However, the total dynamic error of the instrument is the combination of its fidelity and the time lag or phase difference between input and output of the system.

2.31. Measuring Lag. Measuring Lag is of two types :

(i) *Retardation Type.* In this case the response of the instrument begins immediately after a change in the measurand has occurred.

(ii) *Time Delay Type.* In this case the response of the system begins after a 'dead time' after the application of the input. This is shown in Fig. 2'19.

The measurement lags of this type are very small and are of the order of a fraction of a second and can be ignored. But when these systems are subjected to periodically varying inputs, the performance of the instruments with dead time is usually not satisfactory. If the measurand varies at a fast rate, the dead time has a severe adverse effect on the performance of the instrument.

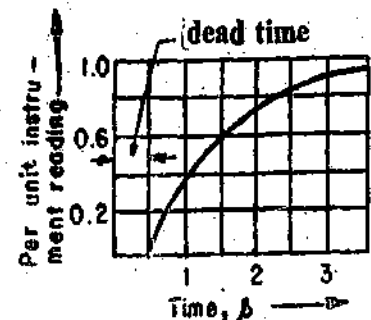

Fig. 2'19. dead time in instruments.

2.32. Standard Signals. The measurement systems may be subjected to any type of input. The type of input signals cannot be known fully ahead of time. In almost all applications the

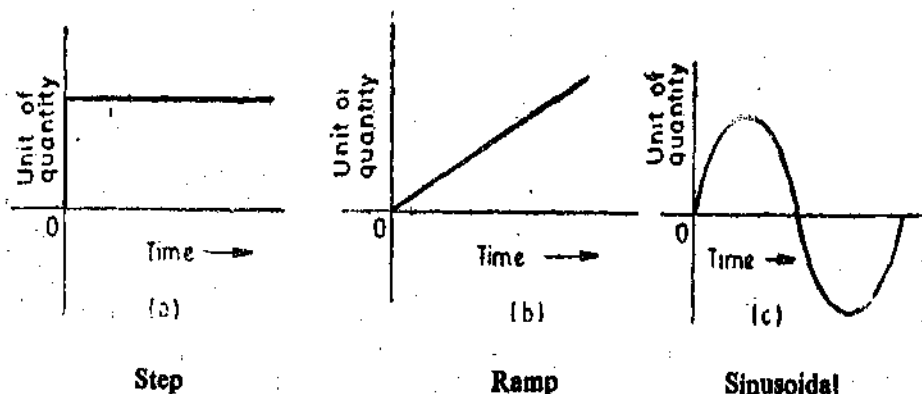

Fig. 2'20. Various types of input functions.

signals are random in nature. Therefore, it becomes difficult to express the actual input signals mathematically by simple equations. Dynamic behaviour of measurement systems can be studied with the help of certain standard signals. These standard signals are :

- (i) Step input, (ii) Ramp input, (iii) Parabolic input, and (iv) Impulse input.

The above signals are used for studying dynamic behaviour in the time domain. For studies in frequency domain, steady state response to a sinusoidal input signal yields a great deal of information. This is because all actual inputs can be thought of consisting of a band of frequencies ranging from zero onwards (All types of signals can be broken into sum of a series of sinusoidal signals according to Fourier series).

When system studies are carried out in time domain, the dynamic behaviour of the system depends upon the system poles and not on type of input. Therefore the system behaviour to any kind of inputs can be predicted by studying its response to one of the standard signals. The standard input chosen for this purpose is a step input.

The step, ramp and sinusoidal signals are shown in Fig. 2'20

2'33. Overshoot. Moving parts of instruments have mass and thus possess inertia. When an input is applied to instruments, the pointer does not immediately come to rest at its steady state (or final deflected) position but goes beyond it or in other words "overshoots" its steady position. The overshoot is defined as the maximum amount by which moving system moves beyond the steady state position. (See Fig. 2'21). In many instruments, especially galvanometers it is desirable to have a little overshoot but an excessive overshoot is undesirable.

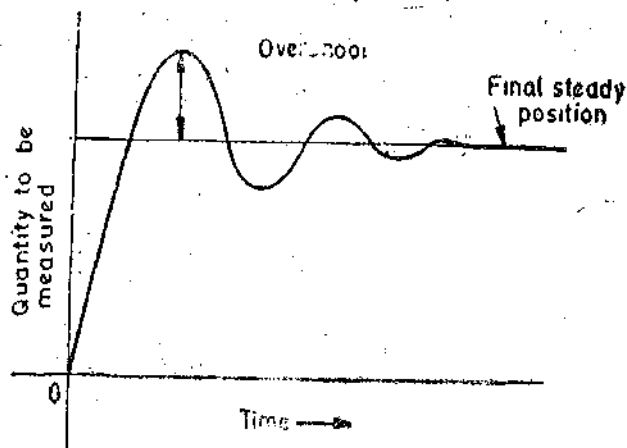

Fig. 2'21. Overshoot.

Example 2'28. A step input of 5 A is applied to an ammeter. The pointer swings to a voltage of 5'18 A and finally comes to rest at 5.02 A. (a) Determine the overshoot of the reading in ampere and in percentage of final reading. (b) Determine the percentage error in the instrument.

Solution. (a) $\text{Overshoot} = 5'18 - 5'02 = 0'16 \text{ A}$

$$\text{Percentage overshoot} = \frac{0'16}{5'02} \times 100 = 3'2\%$$

$$(b) \text{ Percentage error} = \frac{5'02 - 5'0}{5'0} \times 100 = 0'4\%$$

UNSOLVED PROBLEMS

- An ammeter reads 6'7 A and the true value of current is 6'54 A. Determine the error and the correction for this instrument. [Ans. 0'16 A, -0'16 A]
- A voltmeter reads 109.5 V. The error taken from an error curve is -0'37 V. Determine the true voltage. [Ans. 109'87 V]
- The measured value of a voltage is 111 V while its true is 110 V. Calculate the relative error. [Ans. 0'91%]
- A 0-100 V voltmeter has 200 scale divisions which can be read to 1/2 division. Determine the resolution of the meter in volt. [Ans. 0'25 V]
- A diaphragm type pressure measuring instrument is calibrated for absolute pressures of 6 to 760 mm of mercury. It has an accuracy of $\pm 1\%$. Calculate the scale range, scale span and maximum static error. [Ans. 760 mm, 754 mm, $\pm 7'54 \text{ mm}$]
- State the number of significant figures in each of the following :

(a) 542 A, (b) 1'65 V, (c) 21'25 W, (d) 0'00005 Ω , (e) 4×10^4 , (f) 20,002, (g) 0'345 k Ω

[Ans. (a) 3, (b) 3, (c) 4, (d) 5, (e) 1, (f) 5, (g) 3]

7. Four resistors are connected in series. The values of resistors are 28.4Ω , 4.25Ω , 56.605Ω , and 0.75Ω with an uncertainty of one unit in the last digit in each. Calculate the total series resistance, giving only significant figures in the answer. [Ans. 90Ω]

8. A current of 2.56 A is flowing in a resistance of 45.73Ω . Each quantity has an uncertainty of one unit in the last digit. Find the value of voltage drop to the appropriate number of significant figures. [Ans. 117 V]

9. Determine the linearity of a potentiometer to obtain an error not to exceed 1 part in 10,000. [Ans. 0.01%]

10. A recording instrument requires a current of 0.05 A to overcome initial friction and produce motion of the movement. Define this effect and list factors which produce it. [Ans. Dead zone = 0.05 A]

11. The dead zone of a certain pyrometer is 0.125 per cent of the span. The calibration is 800°C to 1800°C . What temperature change must occur before it is detected? [Ans. 12.5°C]

12. What is the true value of voltage across the $500 \text{ k}\Omega$ resistor connected between terminals A and B as shown in Fig. 2'22? What would a voltmeter with a sensitivity of $20 \text{ k}\Omega/\text{V}$ read on the following ranges: 50, 15, 5 volt?

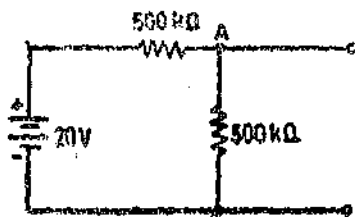

Fig. 2'22

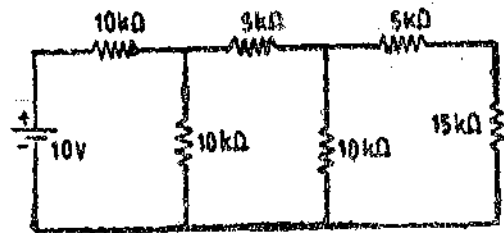

Fig. 2'23

13. What is the true value of current in the $15 \text{ k}\Omega$ resistor of Fig 2'23. If an ammeter of $2 \text{ k}\Omega$ resistance is used to measure the current in the $15 \text{ k}\Omega$ resistor, what will it read? If a loading accuracy of 99 percent is desired in measuring the current, what should the ammeter resistance be? [Ans. $100 \mu\text{A}$, $92.6 \mu\text{A}$, 250Ω]

14. A voltage source has an open circuit voltage of 100 V and an output impedance of $10 + j20 \Omega$. It is connected to a load through a transmission network. The impedance of the load is $20 + jX_L \Omega$ and that of transmission network $R_T - j15 \Omega$. Specify the value of R_T and X_L for maximum power transfer to the load. If the variation in load resistance were permitted, what will be its value for maximum power transfer? [Ans. 10Ω , 5Ω capacitive, 10Ω]

15. A step voltage of 20 V is applied to a voltmeter and it swings to a maximum value of 28.8 V and finally settles to 20 V . Find the percentage overshoot. [Ans. 40%]

16. A self-balancing potentiometer is connected to spatial encoder required to read 2000. The linearity is 0.05% , find the accuracy of the read out system. [Ans. 1 part in 2000]

Errors in Measurements and their Statistical Analysis

3.1 Limiting Errors (Guarantee Errors)

The accuracy and precision of an instrument depends upon its design, the material used and the workmanship that goes into making the instrument. The choice of an instrument for a particular application depends upon the accuracy desired. If only a fair degree of accuracy is desired, it is not economical to use expensive materials and skill into the manufacture of the instrument. But an instrument used for an application requiring a high degree of accuracy has to use expensive material and a highly skilled workmanship. The economical production of any instrument requires the proper choice of material, design and skill. In order to assure the purchaser of the quality of the instrument, the manufacturer guarantees a certain accuracy. In most instruments the accuracy is guaranteed to be within a certain percentage of full scale reading. Components are guaranteed to be within a certain percentage of the rated value. Thus the manufacturer has to specify the deviations from the nominal value of a particular quantity. The limits of these deviations from the specified value are defined as **Limiting Errors** or **Guarantee Errors**.

We can say that the manufacturer guarantees or promises that the error in the item he is selling is no greater than the limit set.

The magnitude of a quantity having a nominal value A_s and a maximum error or limiting error of $\pm\delta A$ must have a magnitude A_o between the limits $A_s - \delta A$ and $A_s + \delta A$ or

$$\text{Actual value } A_o = A_s \pm \delta A \quad \dots(3.1)$$

For example, the nominal magnitude of a resistor is 100Ω with a limiting error of $\pm 10 \Omega$. The magnitude of the resistor will be between the limits :

$$A = 100 \pm 10 \Omega \quad \text{or} \quad A > 90 \Omega \text{ and } A < 110 \Omega$$

In other words the manufacturer guarantees that the value of resistance of the resistor lies between 90Ω and 110Ω .

3.2. Relative (Fractional) Limiting Error

The relative (fractional) error is defined as the ratio of the error to the specified (nominal) magnitude of a quantity. Therefore,

$$\text{relative limiting error } \epsilon_r = \frac{\delta A}{A_s} = \frac{\epsilon_o}{A_s} \quad \dots(3.2)$$

$$\text{or} \quad \epsilon_o = \delta A = \epsilon_r A_s \quad \dots(3.3)$$

Then from Eqn. 3.1, limiting values are :

$$A_o = A_s \pm \delta A = A_s \pm \epsilon_r A_s = A_s (1 \pm \epsilon_r) \quad \dots(3.4)$$

$$\text{Percentage limiting error } \% \epsilon_r = \epsilon_r \times 100 \quad \dots(3.5)$$

In the example considered in Art 3.1, we have $A_s = 100 \Omega$ and $\delta A = \pm 10 \Omega$.

$$\therefore \text{Relative limiting error } \epsilon_r = \frac{\delta A}{A_s} = \pm \frac{10}{100} = \pm 0.1.$$

$$\text{Percentage limiting error } \% \epsilon_r = 0.1 \times 100 = \pm 10\%$$

and limiting values of resistance are :

$$A_a = A_s(1 \pm \epsilon_r) = 100(1 \pm 0.1) = 100 \pm 10 \Omega.$$

In limiting errors the specified quantity A_s is taken as the true quantity, and the quantity which has the maximum deviation from A_s is taken as the erroneous quantity. Thus, we have

$$\delta A = A_a - A_s \quad \dots(3.6)$$

$$\therefore \text{Relative limiting error, } \epsilon_r = \frac{A_a - A_s}{A_s} \quad \dots(3.7)$$

$$= \frac{\text{actual value} - \text{nominal value}}{\text{nominal value}} \quad \dots(3.8)$$

Example 3.1. The value of capacitance of a capacitor is specified as $1 \mu\text{F} \pm 5\%$ by the manufacturer. Find the limits between which the value of the capacitance is guaranteed.

Solution : The guaranteed value of the capacitance lie within the limits :

$$A_a = A_s(1 \pm \epsilon_r) = 1 \times (1 \pm 0.05) = 0.95 \text{ to } 1.05 \mu\text{F}.$$

Note. The same idea of a guarantee limiting the worst possible case applies to electrical measurements. The measurements may involve several components, each of which may be delimited by a guarantee error. Thus, the same treatment is to be followed for quantities under measurement as is followed for specified quantities.

Example 3.2. A 0–150 V voltmeter has a guaranteed accuracy of 1 percent of full scale reading. The voltage measured by this instrument is 75 V. Calculate the limiting error in percent. Comment upon the result.

Solution : The magnitude of limiting error of instrument,

$$\delta A = \epsilon_r A_s$$

$$\therefore \delta A = 0.01 \times 150 = 1.5 \text{ V}.$$

The magnitude of the voltage being measured is 75 V.

$$\text{The relative error at this voltage is } \epsilon_r = \frac{\delta A}{A_s} = \frac{1.5}{75} = 0.02$$

Therefore, the voltage being measured is between the limits of

$$\begin{aligned} A_a &= A_s(1 \pm \epsilon_r) \\ &= 75(1 \pm 0.02) \text{ V} = 75 \pm 1.5 \text{ V}. \end{aligned}$$

$$\text{The percentage limiting error is : } \% \epsilon_r = \frac{1.5}{75} \times 100 = 2 \text{ percent.}$$

Comments. It is important to note that this meter is guaranteed to have an error of less than 1 percent of full scale or the limiting error is 1 percent at the full scale deflection of 150 V. But when the meter reads 75 V, the limiting error is 2 percent. The percent limiting error will be greater if a smaller voltage is measured. If the meter reads 37.5 V, the percentage limiting error is $= \frac{1.5}{37.5} \times 100 = 4.0$ percent.

This increase in the percentage limiting error as small voltages are measured occurs because the magnitude of the limiting error δA is based upon the full scale reading of the meter and is a fixed quantity, while the actual voltage readings can be of any magnitude from 0 to 150 V. We infer from here that the percentage error increases as the voltage being measured decreases.

Thus while selecting instruments, particular care should be taken as regards the range. The values to be measured should not lie in the lower third of the range. This is particularly important if the meter accuracy is specified in terms of the full scale deflection *f.s.d.* (another name for *f.s.d.* is

fiducial value) as considerable error, (as a percentage of actual value), may occur as is Step in Example 3.2. Thus meters which read well up their scale should be selected as far as possible.

Another example is given below which is illustrative of the comments given above :

Example 3.3. A wattmeter having a range 1000 W has an error of $\pm 1\%$ of full scale deflection. If the true power is 100 W, what would be the range of readings ?

Suppose the error is specified as percentage of true value, what would be the range of the readings.

Solution : When the error is specified as a percentage of full scale deflection, the magnitude of limiting error at full scale

$$= \pm \frac{1}{100} \times 1000 = \pm 10 \text{ W.}$$

Thus the wattmeter reading when the true reading is 100 W may be 100 ± 10 W, i.e., between 90 to 110 W.

The relative error $= \frac{\pm 10}{100} \times 100 = \pm 10\%$.

Now suppose the error is specified as percentage of true value.

The magnitude of error $= \pm \frac{1}{100} \times 100 = \pm 1 \text{ W.}$

Therefore the meter may read 100 ± 1 W or between 99 to 101 W.

3.3. Combination of Quantities with Limiting Errors. When two or more quantities, each having a limiting error, are combined, it is advantageous to be able to compute the limiting error of the combination. The limiting error can be easily found by considering the relative increment of the function if the final result is in the form of an algebraic equation.

(i) **Sum of two Quantities.** Let y be the final result which is the sum of measured quantities u and v .

$$\therefore y = u + v.$$

The relative increment of the function is given by

$$\frac{dy}{y} = \frac{d(u+v)}{y} = \frac{du}{y} + \frac{dv}{y}.$$

Expressing the result in terms of relative increment of the component quantities

$$\frac{dy}{y} = \frac{u}{y} \cdot \frac{du}{u} + \frac{v}{y} \cdot \frac{dv}{v}.$$

If the errors in the component quantities are represented by $\pm \delta u$ and $\pm \delta v$ then corresponding limiting error δy in y is given by :

$$\frac{\delta y}{y} = \pm \left(\frac{u}{y} \cdot \frac{\delta u}{u} + \frac{v}{y} \cdot \frac{\delta v}{v} \right) \quad \dots(3.9)$$

The above equation shows that the resultant relative error is equal to the sum of the products formed by multiplying the individual relative errors by the ratio of each term to the function.

(ii) **Difference of two Quantities.**

Let $y = u - v$

$$\therefore \frac{dy}{y} = \frac{du}{y} - \frac{dv}{y}.$$

Expressing the result in terms of relative increments of component quantities

$$\frac{dy}{y} = \frac{u}{y} \cdot \frac{du}{u} - \frac{v}{y} \cdot \frac{dv}{v}$$

If the errors in u, v are $\pm \delta u$ and $\pm \delta v$ respectively, the signs may be interpreted to give the worst possible discrepancy *i.e.* when the error in u is $+\delta u$, the error in v is $-\delta v$ and vice versa, then the corresponding relative limiting error δy in y is given by

$$\frac{\delta y}{y} = \pm \left(\frac{u}{y} \cdot \frac{\delta u}{u} + \frac{v}{y} \cdot \frac{\delta v}{v} \right) \quad \dots(3'10)$$

Eqn. 3'10 is the same as Eqn. 3'9. It may, however, be mentioned that in this case when u and v are almost equal in magnitude *i.e.* when $y = u - v \ll u$ and also $v \ll u$ then the relative error in y would be very large.

(iii) **Sum or Difference of more than two Quantities.** The sum or difference of more than two quantities may be treated in a similar way.

If we have $y = \pm u \pm v \pm w$

Then the limiting error is given by :

$$\frac{\delta y}{y} = \pm \left(\frac{u}{y} \cdot \frac{\delta u}{u} + \frac{v}{y} \cdot \frac{\delta v}{v} + \frac{w}{y} \cdot \frac{\delta w}{w} \right) \quad \dots(3'11)$$

(iv) **Product of two Components.**

Let $y = uv$

$\therefore \log_e y = \log_e u + \log_e v$

Differentiating with respect to y

$$\frac{1}{y} = \frac{1}{u} \cdot \frac{du}{dy} + \frac{1}{v} \cdot \frac{dv}{dy} \quad \text{or} \quad \frac{dy}{y} = \frac{du}{u} + \frac{dv}{v}$$

Representing the errors in u and v as $\pm \delta u$ and $\pm \delta v$ respectively, the error δy in y is given by :

$$\frac{\delta y}{y} = \pm \left(\frac{\delta u}{u} + \frac{\delta v}{v} \right) \quad \dots(3'12)$$

Thus from above we conclude that the relative limiting error of product of terms is equal to the sum of the relative errors of terms.

(v) **Quotient.** Let $y = \frac{u}{v}$

$\therefore \log_e y = \log_e u - \log_e v$

Differentiating with respect to y , we have

$$\frac{1}{y} = \frac{1}{u} \cdot \frac{du}{dy} - \frac{1}{v} \cdot \frac{dv}{dy} \quad \text{or} \quad \frac{dy}{y} = \frac{du}{u} - \frac{dv}{v}$$

Representing the errors in u and v as $\pm \delta u$ and $\pm \delta v$ respectively, the relative error in y is

$$\frac{\delta y}{y} = \pm \left(\frac{\delta u}{u} \mp \frac{\delta v}{v} \right) \quad \dots(3'13)$$

Thus maximum possible error occurs when $\frac{\delta u}{u}$ is +ve and $\frac{\delta v}{v}$ is -ve or vice versa.

\therefore Relative limiting error in y is $\frac{\delta y}{y} = \pm \left(\frac{\delta u}{u} + \frac{\delta v}{v} \right) \quad \dots(3'14)$

The above result is the same as the corresponding result for the product of two quantities.

(vi) Product or Quotient of more than two Quantities.

Let $y = uvw$ or $y = \frac{u}{vw}$ or $y = \frac{1}{uvw}$

Considering Eqns. 3'12 and 3'14, we have relative limiting error for y

$$\frac{\delta y}{y} = \pm \left(\frac{\delta u}{u} + \frac{\delta v}{v} + \frac{\delta w}{w} \right) \quad \dots(3'15)$$

(vii) Power of a Factor

Let $y = u^n \quad \therefore \log_e y = n \log_e u.$

Differentiating with respect to y ,

$$\frac{1}{y} = n \cdot \frac{1}{u} \frac{du}{dy} \quad \text{or} \quad \frac{dy}{y} = n \frac{du}{u}$$

Hence, the relative limiting error of y is $\frac{\delta y}{y} = \pm n \frac{\delta u}{u} \quad \dots(3'16)$

(viii) Composite Factors

Let $y = u^n \cdot v^m$
 $\therefore \log_e y = n \log_e u + m \log_e v$

or $\frac{1}{y} = \frac{n}{u} \cdot \frac{du}{dy} + \frac{m}{v} \frac{dv}{dy}$

or $\frac{dy}{y} = n \frac{du}{u} + m \frac{dv}{v}$

\therefore Relative limiting error of y is $\frac{\delta y}{y} = \pm \left(n \frac{\delta u}{u} + m \frac{\delta v}{v} \right) \quad \dots(3'17)$

Example 3'4. Three resistors have the following ratings :

$$R_1 = 37 \Omega \pm 5\%, \quad R_2 = 75 \Omega \pm 5\%, \quad R_3 = 50 \pm 5\%.$$

Determine the magnitude and limiting error in ohm and in percent of the resistance of these resistances connected in series.

Solution : The values of resistances are :

$$R_1 = 37 \pm \frac{5}{100} \times 37 = 37 \pm 1.85 \Omega$$

$$R_2 = 75 \pm \frac{5}{100} \times 75 = 75 \pm 3.75 \Omega$$

$$R_3 = 50 \pm \frac{5}{100} \times 50 = 50 \pm 2.5 \Omega$$

The limiting value of resultant resistance.

$$R = (37 + 75 + 50) \pm (1.85 + 3.75 + 2.5) = 162 \pm 8.1 \Omega.$$

\therefore Magnitude of resistance = 162 Ω

Error in ohm = $\pm 8.1 \Omega$

Percent limiting error = $\pm \frac{8.1}{162} \times 100 = \pm 5\%.$

Example 3'5. The resistance of a circuit is found by measuring current flowing and the power fed into the circuit. Find the limiting error in the measurement of resistance when the limiting errors in the measurement of power and current are respectively $\pm 1.5\%$ and $\pm 1.0\%$.

Solution : Resistance $R = \frac{(\text{power})}{(\text{current})^2} = \frac{P}{I^2} = PI^{-2}$.

From Eqn. 3.16, relative limiting error in measurement of resistance is

$$\begin{aligned} \frac{\delta R}{R} &= \pm \left(\frac{\delta P}{P} + 2 \frac{\delta I}{I} \right) \\ &= \pm (1.5 + 2 \times 1.0) = \pm 3.5\%. \end{aligned}$$

Example 3.6. The solution for the unknown resistance for a Wheatstone bridge is

$$R_x = \frac{R_2 R_3}{R_1}$$

where

$$R_1 = 100 \pm 0.5\% \Omega, \quad R_2 = 1000 \pm 0.5\% \Omega, \quad R_3 = 842 \pm 0.5\% \Omega$$

Determine the magnitude of the unknown resistance and the limiting error in percent and in ohm for the unknown resistance R_x .

Solution : Unknown resistance

$$R_x = \frac{R_2 R_3}{R_1} = \frac{1000 \times 842}{100} = 8420 \Omega$$

Relative limiting error of unknown resistance is :

$$\frac{\delta R_x}{R_x} = \pm \left(\frac{\delta R_2}{R_2} + \frac{\delta R_3}{R_3} + \frac{\delta R_1}{R_1} \right) = \pm (0.5 + 0.5 + 0.5) = \pm 1.5\%$$

Limiting error in ohm is :

$$= \pm \frac{1.5}{100} \times 8420 = \pm 126.3 \Omega$$

Guaranteed values of resistance are between.

$$8420 - 126.3 = 8293.7 \Omega, \quad 8420 + 126.3 = 8546.3 \Omega$$

Example 3.7. A 4-dial decade box has

decade *a* of $10 \times 1000 \Omega \pm 0.1\%$

decade *b* of $10 \times 100 \Omega \pm 0.1\%$

decade *c* of $10 \times 10 \Omega \pm 0.5\%$

decade *d* of $10 \times 1 \Omega \pm 1.0\%$

It is set at 4639 Ω . Find the percentage limiting error and the range of resistance value.

Solution : Decade *a* is set at 4000 Ω

$$\text{Therefore, error} = \pm 4000 \times \frac{0.1}{100} = \pm 4 \Omega$$

Decade *b* is set at 600 Ω .

$$\text{Therefore, error} = \pm 600 \times \frac{0.1}{100} = \pm 0.6 \Omega$$

Similarly

$$\text{error in decade } c = \pm 30 \times \frac{0.5}{100} = \pm 0.15 \Omega$$

$$\text{error in decade } d = \pm 9 \times \frac{1}{100} = \pm 0.09 \Omega$$

$$\text{Total error} = \pm (4 + 0.6 + 0.15 + 0.09) = \pm 4.84 \Omega$$

$$\text{Relative limiting error } \epsilon_r = \pm \frac{4.84}{4639} = \pm 0.00104$$

$$\text{Percentage limiting error } \% \epsilon_r = \pm (0.00104 \times 100) = \pm 0.104\%$$

$$\begin{aligned} \text{Limiting values of resistance } A_a &= 4639(1 \pm 0.00104) \\ &= 4639 \pm 5 \Omega = 4634 \Omega \text{ to } 4644 \Omega. \end{aligned}$$

Thus we conclude from the above examples that the guarantee values are obtained by taking a direct sum of the possible errors, adopting the algebraic signs that give the worst possible case. In fact setting of guarantee limits is necessarily a pessimistic process. This is true from manufacturer's viewpoint as regards his promise to the buyer, and it is also true of the user in setting accuracy limits in results of measurement.

3.4 Known Errors. When the error of a quantity or an instrument is known the effect of this error, when combined with other errors, can be computed in a manner similar to the combinations of limiting errors. But the difference is that in case of known errors the signs of relative errors are given and must be preserved in the calculations.

Example 3.8. A resistance is rated at 3200 Ω and the current flowing through this is 64 mA. (a) Compute the power loss in the resistor. (b) It was later found that the resistance of the resistor was 0.2 percent greater than the specified resistance and the ammeter read 0.75 percent more than the true current. Determine the known error in the computed power in part (a).

Solution : (a) Power consumed $P = I^2 R = (64 \times 10^{-3})^2 \times 3200 = 13.1 \text{ W}.$

(b) Relative error in power

$$\frac{\delta P}{P} = \left(\frac{2\delta I}{I} + \frac{\delta R}{R} \right) = (2 \times 0.75 + 0.2) = 1.7\% \text{ more.}$$

Example 3.9. Current was measured during a test as 30.4 A, flowing in a resistor of 0.105 Ω . It was discovered later that the ammeter reading was low by 1.2 percent and the marked resistance was high by 0.3 percent. Find the true power as a percentage of the power that was originally calculated.

Solution : True value of	$I = 30.4(1 - 0.012) = 30.035 \text{ A}$
True value of	$R = 0.105(1 + 0.003) = 0.1053 \Omega$
True power	$= I^2 R = (30.035)^2 \times 0.1053 = 95 \text{ W}$
Originally measured power	$= (30.4)^2 \times 0.105 = 97.04 \text{ W}$

$$\frac{\text{True power}}{\text{Originally measured power}} \times 100 = \frac{95}{97.04} \times 100 = 97.9 \text{ percent.}$$

We arrive at the same results by using the following method :

$$\text{Power } P = I^2 R$$

$$\text{Total relative error} = \frac{\delta P}{P} = \frac{2\delta I}{I} + \frac{\delta R}{R} = 2 \times (-0.012) + 0.003 = -0.021$$

$$\therefore \frac{\text{True power}}{\text{Originally measured power}} = 1 - 0.021 = 0.979 = 97.9\%.$$

Example 3.10. Three 250 Ω , a 500 Ω and a 375 Ω resistors are connected in parallel. The 250 Ω resistor has a +0.025 fractional error, the 500 Ω resistor has a -0.036 fractional error, and the 375 Ω resistor has a +0.014 fractional error. Determine (a) the total resistance neglecting errors, (b) total resistance considering the error of each resistor and (c) the fractional error of the total resistance based upon rated values.

Solution :

(a) Total resistance of resistors connected in parallel and neglecting their errors is :

$$R = \frac{1}{1/R_1 + 1/R_2 + 1/R_3} = \frac{1}{1/250 + 1/500 + 1/375} = 115.4 \Omega.$$

(b) The fractional error in $R_1 = 250 \Omega$ is $+0.025$

$$\therefore \delta R_1 = (0.025 \times 250) = +6.25 \Omega$$

$$\text{Hence } R_1 = 250 - 6.25 = 256.25 \Omega$$

Similarly

$$\delta R_2 = (-0.036 \times 500) = -18 \Omega$$

$$\therefore R_2 = 500 - 18 = 482 \Omega$$

$$\delta R_3 = (+0.014 \times 375) = 5.25 \Omega$$

$$\therefore R_3 = 375 + 5.25 = 380.25 \Omega.$$

Therefore the resultant resistance of three resistances in parallel

$$R = \frac{1}{1/R_1 + 1/R_2 + 1/R_3} = \frac{1}{1/256.25 + 1/482 + 1/380.25} = 116.3 \Omega.$$

(c) The fractional error of the parallel resistance based on the rated values is :

$$\frac{\delta R}{R} = \frac{116.3 - 115.4}{115.4} = +0.00776 = +0.776\%.$$

3.5 Types of Errors

No measurement can be made with perfect accuracy but it is important to find out what accuracy actually is and how different errors have entered into the measurement. A study of errors is a first step in finding ways to reduce them. Errors may arise from different sources and are usually classified as under :

1. Gross Errors.
2. Systematic Errors.
3. Random Errors.

3.6 Gross Errors. This class of errors mainly covers human mistakes in reading instruments and recording and calculating measurement results. The responsibility of the mistake normally lies with the experimenter. The experimenter may grossly misread the scale. For example he may, due to an oversight, read the temperature as 31.5°C while the actual reading may be 21.5°C . He may transpose the reading while recording. For example he may read 25.8°C and record 28.5°C . But as long as human beings are involved, some gross errors will definitely be committed. Although complete elimination of gross errors is probably impossible, one should try to anticipate and correct them. Some gross errors are easily detected while others may be very difficult to detect.

Gross errors may be of any amount and therefore their mathematical analysis is impossible. However, they can be avoided by adopting two means. They are :

1. Great care should be taken in reading and recording the data.
2. Two, three or even more readings should be taken for the quantity under measurement. These readings should be taken preferably by different experimenters and the readings should be taken at a different reading point to avoid re-reading with the same error. It should be understood that no reliance be placed on a single reading. It is always advisable to take a large number of readings as a close agreement between readings assures that no gross error has been committed.

3.7 Systematic Errors

These types of errors are divided into three categories :

1. Instrumental Errors.
2. Environmental Errors.
3. Observational Errors.

3.7.1. Instrumental Errors

These errors arise due to three main reasons :

- (i) Due to inherent shortcomings in the instrument,
 - (ii) Due to misuse of the instruments,
- and (iii) Due to loading effects of instruments.

1. Inherent Shortcomings of Instruments. These errors are inherent in instruments because of their mechanical structure. They may be due to construction, calibration or operation of the instruments or measuring devices. These errors may cause the instrument to read too low or too high. For example, if the spring (used for producing controlling torque) of a permanent magnet instrument has become weak, the instrument will always read high.

While making precision measurements, we must recognize the possibility of such errors as it is often possible to eliminate them, or at least reduce them to a great extent by using the following methods :

- (i) The procedure of measurement must be carefully planned. Substitution methods or calibration against standards may be used for the purpose.
- (ii) Correction factors should be applied after determining the instrumental errors.
- (iii) The instrument may be re-calibrated carefully.

2. Misuse of Instruments. There is an old saying that instruments are better than the people who use them. Too often, the errors caused in measurements are due to the fault of the operator than that of the instrument. A good instrument used in an unintelligent way, may give erroneous results. Examples which may be cited for this misuse of instrument may be failure to adjust the zero of instruments, poor initial adjustments, using leads of too high a resistance and so on.

No doubt the above malpractices may not cause a permanent damage to the instrument but all the same they cause errors. However, there are certain ill practices, which in addition to producing errors cause permanent damage to the instruments as a result of overloading and overheating which may ultimately result in failure of the instrument and sometimes the system itself.

3. Loading effects. One of the most common errors committed by beginners, is the improper use of an instrument for measurement work. For example, a well calibrated voltmeter may give a misleading voltage reading when connected across a high resistance circuit (See Example 3.11). The same voltmeter, when connected in a low resistance circuit, may give a more dependable reading (See Example 3.12). These examples illustrate that the voltmeter has a loading effect on the circuit, altering the actual circuit conditions by the measurement process.

Example 3.11. A voltmeter having a sensitivity of 1000 Ω/V reads 100 V on its 150 V scale when connected across an unknown resistor in series with a milliammeter.

When the milli-ammeter reads 5 mA, calculate

- (a) apparent resistance of the unknown resistor,
- (b) actual resistance of the unknown resistor,
- (c) error due to the loading effect of voltmeter.

Solution : Total circuit resistance

$$R_x = \frac{E_x}{I_x} = \frac{100}{5 \times 10^{-3}} = 20 \times 10^3 \Omega = 20 \text{ k}\Omega.$$

Neglecting the resistance of milli-ammeter, the value of unknown resistor is :

$$R_x = 20 \text{ k}\Omega.$$

- (b) Resistance of voltmeter $R_v = 1000 \times 150 = 150 \times 10^3 \Omega = 150 \text{ k}\Omega.$

As the voltmeter is in parallel with the unknown resistance, we have :

$$R_T = \frac{R_x R_V}{R_V + R_x}$$

or unknown resistance $R_x = \frac{R_T R_V}{R_V - R_T} = \frac{20 \times 150}{150 - 20} = 23.077 \text{ k}\Omega$.

(c) Percentage error = $\frac{\text{erroneous quantity} - \text{true quantity}}{\text{true quantity}} \times 100$

$$= \frac{20 - 23.077}{23.077} \times 100 = 13.33\%$$

Example 3.12. Repeat example 3.11 if the milli-ammeter reads 800 mA and the voltmeter reads 40 V on its 150 V scale.

Solution : (a) $R_T = \frac{E_T}{I_T} = \frac{40}{800 \times 10^{-3}} = 50 \Omega$.

(b) $R_V = 1000 \times 150 \Omega = 150 \text{ k}\Omega$.

$\therefore R_x = \frac{R_T R_V}{R_V - R_T} = \frac{50 \times 150 \times 10^3}{150 \times 10^3 - 50} = 50.017 \Omega$.

(c) Percentage error = $\frac{50.0 - 50.017}{50.017} \times 100 = -0.034\%$.

Errors caused by loading effects of the meters can be avoided by using them intelligently. For example when measuring a low resistance by ammeter-voltmeter method a high resistance voltmeter should be used.

In planning any measurement, the loading effect of instruments should be considered and corrections for these effects should be made, if needed, or more suitable instruments should be used. Preferably those methods should be used which result in negligible or no loading effects.

3.7.2. Environmental Errors

These errors are due to conditions external to the measuring device including conditions in the area surrounding the instrument. These may be effects of temperature pressure, humidity, dust, vibrations or of external magnetic or electrostatic fields. The corrective measures employed to eliminate or to reduce these undesirable effects are :

1. Arrangements are made to keep the conditions as nearly as constant as possible. For example, temperature can be kept constant by keeping the equipment in a temperature controlled enclosure.

2. Using equipment which is immune to these effects. For example, variations in resistance with temperature can be minimized by using resistance materials which have a very low resistance temperature co-efficient.

3. Employing techniques which eliminate the effects of these disturbances. For example, the effect of humidity dust etc. can be entirely eliminated by hermetically sealing the equipment.

4. Applying computed corrections : Efforts are normally made to avoid the use of application of computed corrections, but where these corrections are needed and are necessary, they are incorporated for the computations of the results.

3.7.3. Observational Errors

There are many sources of observational errors. As an example, the pointer of a voltmeter rests slightly above the surface of the scale. Thus an error on account of PARALLAX will be in-

curring unless the line of vision of the observer is exactly above the pointer. To minimize parallax errors, highly accurate meters are provided with mirrored scales, as shown in Fig. 3'1.

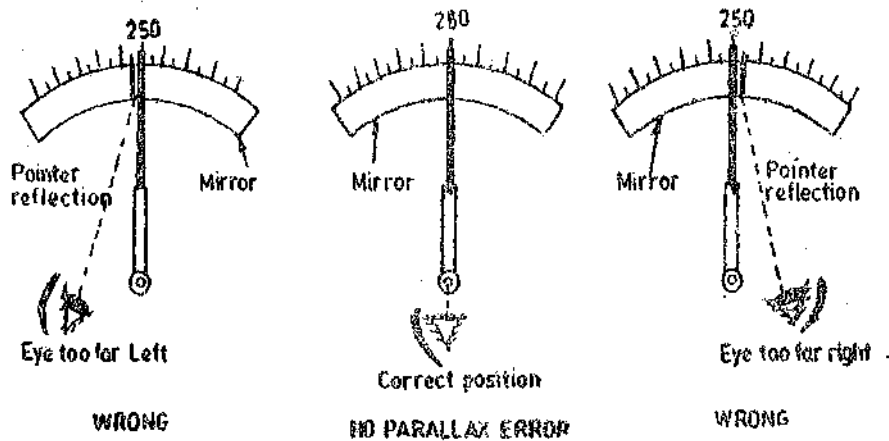

Fig. 3'1. Errors due to Parallax.

When the pointer's image appears hidden by the pointer, observer's eye is directly in line with the pointer. Although a mirrored scale minimizes parallax error, an error is necessarily present though it may be very small.

Since the parallax errors arise on account of pointer and the scale not being in the same plane, we can eliminate this error by having the pointer and the scale in the same plane as shown in Fig. 3'2.

There are human factors involved in measurement. The sensing capabilities of individual observers effect the accuracy of measurement.

No two persons observe the same situation in exactly the same way where small details are concerned. For example, there are observational errors in measurements involving timing of an event. One observer may tend to anticipate the signal and read too soon. Different experimenters may produce different results, especially when sound and light measurements are involved since no two observers possess the same capabilities.

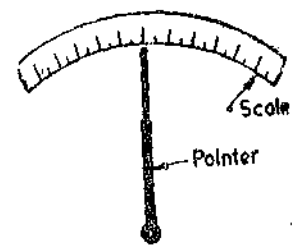

Fig. 3'2. Arrangement showing scale and pointer in the same plane.

Modern electrical instruments have digital display of output which completely eliminates the errors on account of human observational or sensing powers as the output is in the form of digits.

3'8. Random (Residual) Errors

It has been consistently found that experimental results show variation from one reading to another, even after all systematic errors have been accounted for. These errors are due to a multitude of small factors which change or fluctuate from one measurement to another and are due surely to chance. The quantity being measured is affected by many happenings throughout the universe. We are aware of and account for some of the factors influencing the measurement, but about the rest we are unaware. The happenings or disturbances about which we are unaware are lumped together and called "Random" or "Residual". Hence the errors caused by these happenings are called Random (or Residual) Errors. Since these errors remain even after the systematic errors have been accounted for, we call these errors as Residual (Random) Errors.

3'9. Central Value: As stated above, the random errors are caused by a large number of small effects, each one being a variable. These variables may be additive in some cases and subtractive in some cases in their effect on the quantity being measured. In many measurements the positive and negative effects are nearly equal, so that the resultant error is small. If we make a large number of measurements and the plus effects are equal to the minus effects, they would cancel each other and we would obtain the scatter round a Central Value. Since this condition is frequent, in practice, we are justified in using this concept as a basis of our study of errors which are unknown.

to us. Thus mathematical laws or "Probability" can be applied for the study of random errors. There is no other way as the random errors are unknown and only statistical study can lead us to the best approximation of the true value of the quantity under study.

3'10. Statistical Treatment of Data

The experimental data is obtained in two forms of tests :

(i) Multisample test, and (ii) Single-sample test.

Multisample Test. In this test, repeated measurement of a given quantity are done using different test conditions such as employing different instruments, different ways of measurement and by employing different observers. Simply making measurements with the same equipment, procedure, technique and same observer do not provide multisample results.

Single Sample Test. A single measurement (or succession of measurements) done under identical conditions excepting for time is known as single-sample test.

In order to get the exact value of the quantity under measurement, tests should be done using as many different procedures, techniques and experimenters as practicable. It should be borne in mind that the statistical means which help us to arrive at correct results are only valid for multi-sample tests.

3'10'1. Histogram

When a number of multisample observations are taken experimentally there is a scatter of the data about some central value. One method presenting test results in the form of a **Histogram**. The technique is illustrated in Fig. 3'3 representing the data given in Table 3'1. This table shows a set of fifty readings of a length measurement. The most probable or central value of length is 100 cm and the data are taken and recorded to the nearest 0'1 cm.

Table 3'1

Length cm.	Number of readings
99'7	1
99'8	4
99'9	12
100'0	19
100'1	10
100'2	3
100'3	1

Total number of readings = 50.

This histogram of Fig. 3'3 represents these data where the ordinate indicate the number of observed readings (frequency of occurrence) of a particular value. A histogram is also called a **frequency distribution curve**. At the central value of 100 cm is a large number of readings, 19 in this case, with other values placed almost symmetrically on either side. If smaller incremental steps, say 100 readings at 0'05 cm intervals are taken, the general form of the histogram will be almost the same but since the steps have smaller increments and we get a smoother curve.

With more and more data taken at smaller and smaller increments the histogram would finally change into a smooth curve, as indicated by the dashed line in Fig. 3'3.

The smooth curve is symmetrical with respect to the central value. Many physical cases have been found which give experimental data agreeing fairly well with the smooth symmetrical curve.

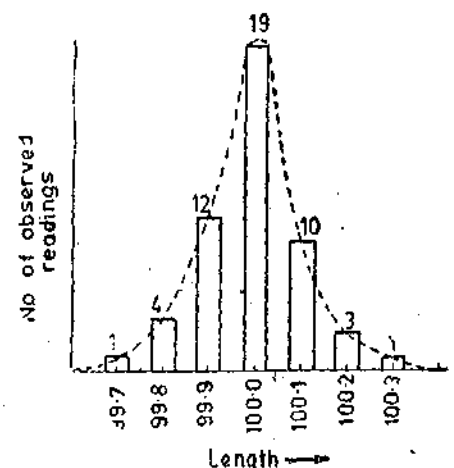

Fig. 3'3. Histogram.

3'10'2. Arithmetic Mean

The most probable value of measured variable (variate) is the arithmetic mean of the number of readings taken. The best approximation is made when the number of readings of the same quantity are very large. Theoretically, an infinite number of readings would give the best result, although in practice, only a finite number of measurements can be made.

The arithmetic mean is given by :

$$\bar{X} = \frac{x_1 + x_2 + x_3 + x_4 + \dots + x_n}{n} = \frac{\sum x}{n} \quad \dots(3'17)$$

where \bar{X} = arithmetic mean,
 x_1, x_2, \dots, x_n = readings or variates or samples,
 and n = number of readings.

3'10'3. Measure of Dispersion from the Mean

Dispersion. The property which denotes the extent to which the values are dispersed about the central value is termed as **dispersion**. The other names used for dispersion are spread or scatter.

Fig. 3'4 shows two sets of data. In one case (curve 1) the values vary from x_1 to x_2 and in other case (curve 2) the values vary from x_3 to x_4 , though their central value is the same. Clearly set of data represented by curve 1 has a smaller dispersion than that of the data represented by curve 2.

It is very important to have a measure of the dispersion from the central value, as it is an indication of the degree of consistency (precision) and regularity of the data.

A large dispersion indicates that some factors involved in the measurement process are not under close control and therefore it becomes difficult to estimate the measured quantity with confidence and definiteness. For example, if we compare two sets of data and find that one set has less dispersion than the other set, we can certainly place more reliance on it and can definitely regard it as a superior set as regards random errors.

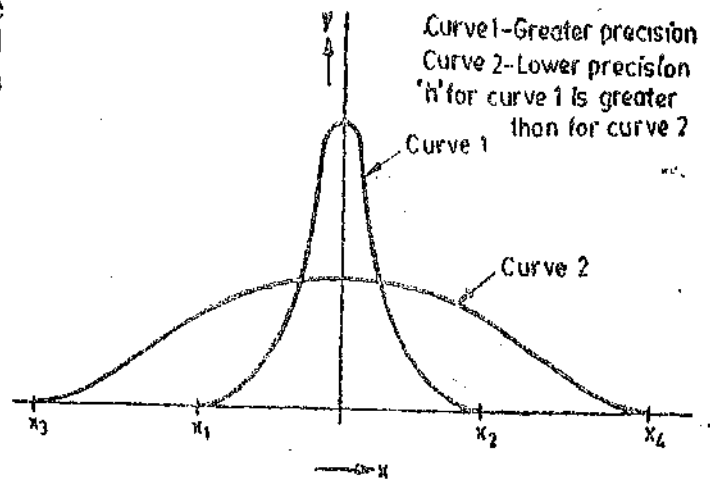

Fig. 3'4. Curves showing different ranges and precision indices.

There are certain terms which must be defined as they form the basis of defining the measure of dispersion of data.

3'10'4. Range. The simplest possible measure of dispersion is the **range** which is the difference between greatest and least values of data. For example in Fig. 3'4 the range of curve 1 is $(x_2 - x_1)$ and that of curve 2 is $(x_4 - x_3)$.

3'10'5. Deviation. Deviation is departure of the observed reading from the arithmetic mean of the group of readings. Let the deviation of reading x_1 be d_1 and that of reading x_2 be d_2 , etc.

Then

$$d_1 = x_1 - \bar{X}$$

$$d_2 = x_2 - \bar{X}$$

$$\dots\dots\dots$$

$$d_n = x_n - \bar{X} \quad \dots(3'18)$$

and

$$\bar{X} = \frac{\sum (x_n - d_n)}{n} \quad \dots(3'19)$$

$$\begin{aligned} \text{Algebraic sum of deviations is : } & d_1 + d_2 + d_3 + \dots + d_n \\ & = (x_1 - \bar{X}) + (x_2 - \bar{X}) + (x_3 - \bar{X}) + \dots + (x_n - \bar{X}) \\ & = (x_1 + x_2 + x_3 + \dots + x_n) - n\bar{X} = 0 \text{ as } x_1 + x_2 + x_3 + \dots + x_n = n\bar{X}. \end{aligned}$$

Therefore the algebraic sum of deviations is zero.

3'10'6. Average Deviation. The average deviation is an indication of the precision of the instruments used in making the measurements. Highly precise instruments yield a low average deviation between readings.

Average deviation is defined as the sum of the absolute values of deviations divided by the number of readings. The absolute value of deviation is the value without respect to its sign. Average deviation may be expressed as :

$$D = \frac{|d_1| + |d_2| + |d_3| + \dots + |d_n|}{n} = \frac{\sum |d|}{n} \quad \dots(3'20)$$

3'10'7. Standard Deviation (S.D.). Another important term in the analysis of random errors is the standard deviation or the root mean square deviation. The Standard Deviation of an infinite number of data is defined as the square root of the sum of the individual deviations squared, divided by the number of readings.

Thus standard deviation is :

$$S.D. = \sigma = \sqrt{\frac{d_1^2 + d_2^2 + \dots + d_n^2}{n}} = \sqrt{\frac{\sum d^2}{n}} \quad \dots(3'21)$$

In practice, however, the number of observations is finite. When the number of observations is greater than 20, S.D. is denoted by symbol σ while if it is less than 20, the symbol used is s . The Standard Deviation of a finite number of data is given by :

$$s = \sqrt{\frac{d_1^2 + d_2^2 + d_3^2 + \dots + d_n^2}{n-1}} = \sqrt{\frac{\sum d^2}{n-1}} \quad \dots(3'22)$$

3'10'8. Variance. The variance is the mean square deviation, which is the same as S.D., except that square root is not extracted.

$$\begin{aligned} \text{Variance} \quad V &= (\text{Standard Deviation})^2 \\ &= (S.D.)^2 = \sigma^2 = \frac{d_1^2 + d_2^2 + d_3^2 + \dots + d_n^2}{n} \end{aligned} \quad \dots(3'23)$$

$$= \frac{\sum d^2}{n} \quad \dots(3'24)$$

But when the number of observations is less than 20

$$\text{Variance} \quad V = s^2 = \sum \frac{d^2}{n-1} \quad \dots(3'25)$$

Example 3'13. A set of independent current measurements were taken by six observers and were recorded as 12.8 A, 12.2 A, 12.5 A, 13.1 A, 12.9 A, and 12.4 A. Calculate (a) the arithmetic mean, (b) the deviations from the mean, (c) the average deviation, (d) the standard deviation, and (e) variance.

Solution. (a) From Eqn. 3'17, the arithmetic mean is

$$\bar{X} = \frac{\sum x}{n} = \frac{12.8 + 12.2 + 12.5 + 13.1 + 12.9 + 12.4}{6} = 12.65 \text{ A.}$$

(b) From Eqn. 3'18, the deviations are :

$$\begin{aligned} d_1 &= x_1 - \bar{X} = 12.8 - 12.65 = +0.15 \text{ A} \\ d_2 &= x_2 - \bar{X} = 12.2 - 12.65 = -0.45 \text{ A} \\ d_3 &= x_3 - \bar{X} = 12.5 - 12.65 = -0.15 \text{ A} \\ d_4 &= x_4 - \bar{X} = 13.1 - 12.65 = +0.45 \text{ A} \\ d_5 &= x_5 - \bar{X} = 12.9 - 12.65 = +0.25 \text{ A} \\ d_6 &= x_6 - \bar{X} = 12.4 - 12.65 = -0.25 \text{ A} \end{aligned}$$

(c) From Eqn. 3'20, average deviation :

$$D = \frac{\sum |d|}{n} = \frac{0.15 + 0.45 + 0.15 + 0.45 + 0.25 + 0.25}{6} = 0.283 \text{ A}.$$

(Note that for average deviation we have not to consider the signs).

(d) Since we have observations whose number is less than 20 therefore we use Eqn. 3'25 for determining the value of standard deviation

$$\begin{aligned} s &= \sqrt{\frac{\sum d^2}{n-1}} = \sqrt{\frac{(0.15)^2 + (-0.45)^2 + (-0.15)^2 + (0.45)^2 + (0.25)^2 + (-0.25)^2}{6-1}} \\ &= 0.399 \text{ A} \end{aligned}$$

(e) Variance $V = s^2 = (0.399)^2 = 0.115 \text{ A}^2$.

3'10'9. **Normal or Gaussian Curve of Errors.** The Normal or Gaussian law of errors is the basis for the major part of study of random effects. This type of distribution is most frequently met in practice.

The law of probability states the normal occurrence of deviations from average value of an infinite number of measurements or observations can be expressed by :

$$y = \frac{h}{\sqrt{\pi}} e^{-h^2 x^2} \quad \dots(3'26)$$

Note : The student here is cautioned not to confuse x with magnitude of a quantity. Here x means Deviation.

where x = magnitude of deviation,
 y = number of readings at any deviation x ,
 (the probability of occurrence of deviation x),
 and h = a constant called precision index.

Eqn. 3'28 leads to curve of type shown in Fig. 3'5 and this curve showing y plotted against x is called "Normal or Gaussian Probability Curve".

This curve is symmetrical about the arithmetic mean value, and area under the curve is unity. Under the conditions specified here the total number of readings taken is represented by I . This can be explained as follows : Suppose for the time being that we consider $h/\sqrt{\pi}$ to be unknown and replace it by the symbol A . If we have a large number of readings, n , the probable number Δn , with deviation between x and $x + \Delta x$ is given by :

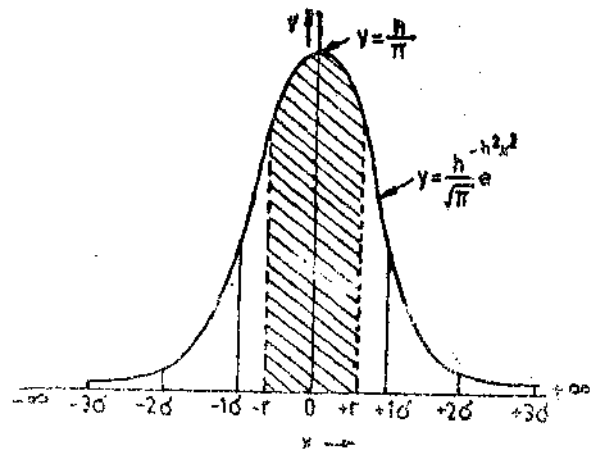

Fig. 3'5. Normal probability curve.

$$\Delta n = ny \Delta x = nA e^{-h^2 x^2} \Delta x.$$

If we integrate the above expression for $-\infty$ to $+\infty$ we shall have all the cases, or

$$A \int_{-\infty}^{\infty} e^{-h^2 x^2} dx = n$$

Thus :

$$A \int_{-\infty}^{\infty} e^{-h^2 x^2} dx = 1 \quad \text{or} \quad \frac{h}{\sqrt{\pi}} \int_{-\infty}^{\infty} e^{-h^2 x^2} dx = 1 \quad \dots(3.27)$$

Thus the integral of y from $-\infty$ to $+\infty$ is equal to unity. The fraction of the total number of readings occurring between the values x_1 and x_2 will be equal to the area under the curve between these values of x .

$$n_{1-2} = \frac{h}{\sqrt{\pi}} \int_{x_1}^{x_2} e^{-h^2 x^2} dx \quad \dots(3.28)$$

where

n_{1-2} = number of readings occurring between the values x_1 and x_2 .

If the area between x_1 and x_2 is 0.5, then 50 per cent of the deviations fall between x_1 and x_2 .

In general the probability for finding a deviation in an interval between x_1 and x_2 becomes

$$P(x_1, x_2) = \int_{x_1}^{x_2} y dx = \frac{h}{\sqrt{\pi}} \int_{x_1}^{x_2} e^{-h^2 x^2} dx \quad \dots(3.29)$$

The fraction of the total number of deviations falling between zero and x are :

$$n_{0-x} = \frac{h}{\sqrt{\pi}} \int_0^x e^{-h^2 x^2} dx \quad \dots(3.30)$$

3.10.10. Precision Index.

From Eqn. 3.26 when $x=0$, we have $y = \frac{h}{\sqrt{\pi}}$... (3.31)

Thus it is clear from above that the maximum value of y depends upon h . The larger the value of h , the sharper the curve. Thus the value of h determines the sharpness of the curve since the curve drops sharply owing to the term $(-h^2)$ being in the exponent. A sharp curve evidently indicates that the deviations are more closely grouped together around deviation $x=0$.

Fig. 3.4 shows two curves having different values of h . Curve 1 has a large value of h while Curve 2 has a smaller value of h .

It is clear that the probability that a variate lies in a given range becomes less as the deviation of the range becomes greater. For a given deviation x , the probability is less greater the h and vice versa. Thus the name precision index for h is reasonable. A large value of h represents high precision of the data because the probability of occurrence of variates in a given range falls off rapidly as the deviation increases because the variates tend to cluster (become closer) into a narrow range. On the other hand, a small value of h represents low precision because the probability of occurrences of variates in a given range falls off gradually as the deviation increases; this is because the variates are spread over a wide range.

It is evident therefore that Curve 1 of Fig. 3.4 represents a data of greater precision than that of Curve 2 since the value of h for Curve 1 is greater than that of Curve 2. we have

$$h = \frac{1}{\sqrt{2\sigma}} \quad \dots(3.32)$$

3.10.11. Probable Error. We have observed above that the most probable or best value of a Gaussian distribution is obtained by taking arithmetic mean of the various values of the variate. In addition it has been indicated that the confidence in this best value (most probable value) is connected with the sharpness of the distribution curve.

Let us consider the two points $-r$ and $+r$ marked in Fig 3.5. These points are so located that the area bounded by the curve, the x axis, and the ordinates erected at $x=-r$ and $x=+r$ is equal to half of the total area under the curve. That is half the deviations lie between $x = \pm r$.

A convenient measure of precision is the quantity r . It is called **Probable Error** or simply **P.E.** The reason for this name is the fact mentioned above that half the observed values lie between the limits $\pm r$. If we determine r as the result of n measurements and then make an additional measurement, the chances are 50-50 percent that the new value will lie between $-r$ and $+r$. That is, the chances are even that any one reading will have an error no greater than $\pm r$.

The location of point r can be found from Eqn. 3.28, by putting

$$\frac{h}{\sqrt{\pi}} \int_{-r}^{+r} e^{-h^2x^2} dx = \frac{1}{2}$$

This gives $r = \frac{0.4764}{h} \quad \dots(3.33)$

3.10.12. Average Deviation for the Normal Curve

The average deviation may be computed when more than one reading is present at a given deviation by multiplying the amount of the deviation by the number of points on the deviation. Then this product is added to other similar products (without regard to sign) until all readings are taken into account ; then divide by the number of readings.

In the case of normal curve,

$$\begin{aligned} \text{Average deviation } \bar{D} &= \int_{-\infty}^{+\infty} |x| y dx \\ &= \frac{2h}{\sqrt{\pi}} \int_0^{+\infty} e^{-h^2x^2} x dx = \frac{1}{\sqrt{\pi h}} \end{aligned} \quad \dots(3.34)$$

From Eqn. 3.33, $h = \frac{0.4764}{r}$. Putting this value in Eqn. 3.35, we have, average deviation :

$$\bar{D} = \frac{r}{0.8453} \quad \dots(3.35)$$

3.10.13. Standard Deviation for the Normal Curve

The standard deviation is given by $\sigma^2 = \frac{\sum d^2}{n}$ (See Eqn. 3.21)

Following a method similar to that followed above, we have :

$$\sigma = \frac{2h}{\sqrt{\pi}} \int_0^{+\infty} e^{-h^2 x^2} x^2 dx = \frac{1}{2h^2}$$

or standard deviation for normal curve

$$\sigma = \frac{1}{\sqrt{2h}} \quad \dots(3.36)$$

$$= \frac{r}{0.6745} \quad \dots(3.37)$$

$$\text{From Eqns. 3.35 and 3.37, we have P.E.} = r = 0.8453 \bar{D} \quad \dots(3.38)$$

$$= 0.6745 \sigma \quad \dots(3.39)$$

3.10.14. Probable Error of a Finite Number of Readings

In the analysis of the normal Gaussian error curve we have assumed that an infinite number of readings were taken. All the formulae derived above are based upon this assumption. With a finite number of readings, there is a slight difference between the computed values given above and the values obtained with a finite set of readings. For example, substitution of Eqn. 3.21 into Eqn. 3.39 gives the probable error as

$$r = 0.6745 \sqrt{\frac{d_1^2 + d_2^2 + d_3^2 + \dots + d_n^2}{n}} \quad \dots(3.40)$$

for an infinite number of deviations forming the normal probability curve, where n is infinite. But for a finite number of deviations, the probable error for one reading is :

$$r_1 = 0.6745 \sqrt{\frac{d_1^2 + d_2^2 + d_3^2 + \dots + d_n^2}{n-1}} = 0.6745 \sqrt{\frac{\sum |d|^2}{n-1}} \quad \dots(3.41)$$

This in fact means that, for a computed probable error r obtained from n readings, one more reading would have an even chance of being above or below r_1 .

With a finite number of readings, the average reading has a probable error of :

$$\begin{aligned} r_m &= \frac{1}{\sqrt{n}} r_1 = 0.6745 \sqrt{\frac{d_1^2 + d_2^2 + d_3^2 + \dots + d_n^2}{n(n-1)}} \\ &= 0.6745 \sqrt{\frac{\sum |d|^2}{n(n-1)}} \quad \dots(3.42) \end{aligned}$$

The above equation means that for n finite readings, the probable error is r_m .

If we have $n \gg 1$ then $n-1 \approx n$

$$\text{and } r_1 \approx 0.6745 \sigma \quad \dots(3.43)$$

$$\text{and } r_m \approx 0.6745 \frac{\sigma}{\sqrt{n}} \quad \dots(3.44)$$

3.10.15. Standard Deviation of Mean. When we have a multiple sample data, it is evident that the mean of various sets of data can be analyzed by statistical means. This is done by taking standard deviation of the mean.

$$\text{The standard deviation of the mean is given by } \sigma_m = \frac{\sigma}{\sqrt{n}} \quad \dots(3.45)$$

3'10'16. Standard Deviation of Standard Deviation

For a multiple sample data, the standard deviation of the standard deviation is :

$$\sigma_{\sigma} = \frac{\sigma}{\sqrt{2n}} \quad \dots(3'46)$$

$$= \frac{\sigma_m}{\sqrt{2}} \quad \dots(3'47)$$

Example 3'14. The following 10 observations were recorded when measuring a voltage : 41'7, 42'0, 41'8, 42'0, 42'1, 41'9, 42'0, 41'9, 42'5 and 41'8 volt. Find (i) the mean (ii) the standard deviation (iii) the probable error of one reading (iv) the probable error of mean and (v) range.

Solution : For the sake of ease in calculations, the observations are tabulated and manipulated as under :

x	a	d ²
41'7	-0'27	0'0729
42'0	+0'03	0'0009
41'8	-0'17	0'0289
42'0	+0'03	0'0009
42'1	+0'13	0'0169
41'9	-0'07	0'0049
42'0	+0'03	0'0049
41'9	-0'07	0'0049
42'5	+0'53	0'2809
41'8	-0'17	0'0289
$\Sigma x = 419'7$		$\Sigma d^2 = 0'441$

(i) Mean length $\bar{X} = \frac{\Sigma x}{n} = \frac{41'97}{10} = 41'97$ volt.

(ii) The value of standard deviation is $\sigma = \sqrt{\frac{d^2}{n}} = \sqrt{\frac{0'441}{10}} = 0'21$ volt (See Eqn 3'21)

if the data is considered to be a set of infinite readings. However, the number of observations is only 10 and therefore the standard deviation is :

$$s = \sqrt{\frac{d^2}{n-1}} = \sqrt{\frac{0'441}{(10-1)}} = 0'22 \text{ volt} \quad \text{(See Eqn. 3'25)}$$

(iii) Probable error $r_1 = 0'6745 s = 0'15$ volt. (See Eqn. 3'41)

(iv) Probable error of mean $r_m = \frac{r_1}{\sqrt{n-1}} = \frac{0'15}{\sqrt{9}} = 0'05$ volt. (See Eqn. 3'42)

(v) Range = 42'5 - 41'7 = 0'8 volt,

Example 3.15. In a test temperature is measured 100 times with variations in apparatus and procedures. After applying the corrections, the results are :

Temperature °C	397	398	399	400	401	402	403	404	405
Frequency of occurrence	1	3	12	23	37	16	4	2	2

Calculate (a) arithmetic mean, (b) mean deviation, (c) standard deviation, (d) the probable error of one reading, (e) the standard deviation and the probable error of the mean, (f) the standard deviation of the standard deviation.

Solution : The computations are done in a tabular form as under :

Temperature T°C	Frequency of occurrence, f	T×f	Deviation d	f×d	d ²	f×d ²
397	1	397	-3.78	-3.78	14.288	14.288
398	3	1194	-2.78	-8.34	7.728	23.185
399	12	4788	-1.78	-21.36	3.168	38.020
400	23	9200	-0.78	+17.94	0.608	13.993
401	37	14837	+0.22	+8.14	0.048	1.708
402	16	6432	+1.22	+19.52	1.488	23.814
403	4	1612	+2.22	+8.88	4.928	19.714
404	2	808	+3.22	+6.44	10.368	20.737
405	2	810	+4.22	+8.44	17.808	35.618
Total	100	40078		$\Sigma f \times d $ =102.8		$\Sigma f d^2 =$ 191.08

$$(a) \text{ Mean temperature} = \frac{400.78}{100} = 400.780^\circ\text{C}$$

$$(b) \text{ Mean deviation } \bar{d} = \frac{102.8}{100} = 1.028^\circ\text{C}$$

$$(c) \text{ Standard deviation } \sigma = \sqrt{\frac{191.08}{100}} = 1.380^\circ\text{C}$$

$$(d) \text{ Probable error of one reading } r_1 = 0.6745 \sigma = 0.6745 \times 1.38 = 0.93^\circ\text{C}$$

(e) Probable error of the mean $r_m = \frac{0.93}{\sqrt{100}} = 0.093^\circ\text{C}$

Standard deviation of the mean $\sigma_m = \frac{0.93}{\sqrt{100}} = 0.138^\circ\text{C}$

(f) Standard deviation of the standard deviation

$$\sigma_\sigma = \frac{\sigma_m}{\sqrt{2}} = \frac{0.138}{\sqrt{2}} = 0.0796^\circ\text{C}.$$

3.11. Specifying ODDS

The probability of occurrence can be stated in terms of ODDS. Odds is the number of chances that a particular reading will occur when the error limit is specified. For example, if the error limits are specified as $\pm 0.6745\sigma$, the chances are that 50% of the observations will lie between the above limits or in other words we can say that odds are 1 to 1.

The odds can be calculated as under

$$\frac{\text{odds}}{\text{odds}+1} = \text{probability of occurrence} \quad \dots(3.48)$$

The odds that the observation lies between $\pm\sigma$ limits are :

$$\frac{\text{odds}}{\text{odds}+1} = 0.6828 \quad \text{or} \quad \text{odds are } 2.15 : 1.$$

Table 3.3 gives the deviations, the probability of occurrence and the odds.

TABLE 3.3

Deviation	Probability	Odds
$\pm 0.6745\sigma$	0.5000	1 to 1
$\pm \sigma$	0.6828	2.15 to 1
$\pm 2\sigma$	0.9546	21 to 1
$\pm 3\sigma$	0.9974	256 to 1

3.12. Specifying Measurement Data

After doing the statistical analysis of the multisample data, we must specify the results. The results are expressed as deviations about a mean value. The deviations are expressed as :

(i) *Standard deviation* : The result is expressed as $\bar{X} \pm \sigma$

The error limit in this case is the standard deviation. This means that 0.6828 (about 68%) of the readings are within the limits $\sigma = \pm 1$ and the odds are 2.15 to 1. Thus there is approximately a 2 to 1 possibility that a new observation will fall beyond this limit.

(ii) *Probable error* : The result is expressed as $\bar{X} \pm 0.6745\sigma$.

This means that 50% of the readings lie within this limit and the odds are 1 to 1. This means that there is an even possibility that a new reading will lie within these limits.

(iii) $\pm 2\sigma$ limits: In case we went to increase our probability range we specify the results as:

$$\bar{X} \pm 2\sigma.$$

Thus we assume that 0.9546 (or about 95%) of readings fall within these limits. These odds in this case are 21 to 1.

(iv) $\pm 3\sigma$ limits: The results in this case are expressed as:

$$\bar{X} \pm 3\sigma.$$

The maximum or boundary error limit is $\pm 3\sigma$. The probability in this case is 0.9974. This means that 99.74% of the observations will fall within this limit. In other words we can say that there is a possibility of only 26 readings out of 1000 to fall beyond these limits. Thus practically all the observations are included in this limit. The odds of any observation falling out of this limit are 256 to 1.

3.13. Variance and Standard Deviations of Combination of Components

Suppose X is a function of several component variables, each of which is subject to random effects, thus we have:

$$X = f(x_1, x_2, \dots, x_n).$$

Now if x_1, x_2, \dots, x_n are independent variables, then for small variations in x_1, x_2, \dots, x_n from their mean value, denoted by $\delta x_1, \delta x_2, \dots, \delta x_n$, the resulting variations of X from its mean value for any one determination is given by:

$$\delta X = \frac{\partial X}{\partial x_1} \cdot \delta x_1 + \frac{\partial X}{\partial x_2} \cdot \delta x_2 + \dots \quad \dots(3.49)$$

(Eqn. 3.49, ignores the higher differentials).

Squaring Eqn. 3.49, we obtain

$$(\delta X)^2 = \left(\frac{\partial X}{\partial x_1}\right)^2 (\delta x_1)^2 + \left(\frac{\partial X}{\partial x_2}\right)^2 (\delta x_2)^2 + \dots + 2 \left(\frac{\partial X}{\partial x_1}\right) \left(\frac{\partial X}{\partial x_2}\right) (\delta x_1 \delta x_2) + \dots \quad \dots(3.50)$$

Now, if the variations of x_1, x_2 etc., are independent, as assumed, positive values of one increment are equally likely to be associated with positive or negative values of other increments. Thus the sum of the cross product terms tends to be zero for repeated measurements. By definition, variance V is the mean square error. Thus the mean of $(\delta X)^2$ becomes the variance of X for repeated measurements. This variance of X is denoted by V_x and hence we can write:

$$V_x = (\delta X)^2 \\ = \left(\frac{\partial X}{\partial x_1}\right)^2 V_{x1} + \left(\frac{\partial X}{\partial x_2}\right)^2 V_{x2} + \dots + \left(\frac{\partial X}{\partial x_n}\right)^2 V_{xn} \quad \dots(3.51)$$

as in repeated measurements $(\delta x_1)^2$ tends to become mean value of variance of x_1 , i.e., V_{x1} .

$$\therefore \text{Eqn. 3.51 may be written as } V_x = V_{x1} + V_{x2} + \dots + V_{xn} \quad \dots(3.52)$$

This shows the component variances are additive with weighing factors $(\delta X/\delta x_1)^2$. The weighted variance x_1 can be written as

$$V_{x1} = \left(\frac{\partial X}{\partial x_1}\right)^2 V_{x1} \quad \dots(3.53)$$

The standard deviation of X may be found from Eqn. 3.51.

The standard deviation of X is σ_x and is equal to

$$\sigma_x = \sqrt{V_x} = \sqrt{\left(\frac{\partial X}{\partial x_1}\right)^2 V_{x1} + \left(\frac{\partial X}{\partial x_2}\right)^2 V_{x2} + \dots + \left(\frac{\partial X}{\partial x_n}\right)^2 V_{xn}} \quad \dots(3.54)$$

but $V_{xn} = \sigma_{xn}^2$

$$\begin{aligned} \sigma_x &= \sqrt{\left(\frac{\partial X}{\partial x_1}\right)^2 V_{x_1} + \left(\frac{\partial X}{\partial x_2}\right)^2 V_{x_2} + \dots + \left(\frac{\partial X}{\partial x_n}\right)^2 V_{x_n}} \\ &= \sqrt{\left(\frac{\partial X}{\partial x_1}\right)^2 \sigma_{x_1}^2 + \left(\frac{\partial X}{\partial x_2}\right)^2 \sigma_{x_2}^2 + \dots + \left(\frac{\partial X}{\partial x_n}\right)^2 \sigma_{x_n}^2} \end{aligned} \quad \dots(3.55)$$

It is clear from Eqn. 3.55 that both component standard deviations are additive with weighing factors $\left(\frac{\partial X}{\partial x_1}\right)^2$, etc. which express the relative influence of the various components on the combined function.

Therefore we can write $\sigma_x = \sqrt{\sigma_{x_1}^2 + \sigma_{x_2}^2 + \dots + \sigma_{x_n}^2}$... (3.56)

where σ_{x_1} is the weighted standard deviation of x_1 .

$$\sigma_{x_1} = \left(\frac{\partial X}{\partial x_1}\right)^2 \sigma_{x_1} \quad \dots(3.57)$$

It is important to note that the above expressions are valid only if component quantities x_1, x_2, \dots etc. are independent of each other and also that the increments are small so that the terms of higher order than the first may be neglected. Actually in engineering applications, the increments are small as it is generally possible to keep the random effects under control.

3.13.1. Probable Error of Combination of Components

Suppose X is a function of several component variables x_1, x_2, \dots, x_n , each of which is an independent variate.

Then we have the standard deviation as

$$\sigma X = \sqrt{\left(\frac{\partial X}{\partial x_1}\right)^2 \sigma_{x_1}^2 + \left(\frac{\partial X}{\partial x_2}\right)^2 \sigma_{x_2}^2 + \dots + \left(\frac{\partial X}{\partial x_n}\right)^2 \sigma_{x_n}^2}$$

But from Eqn. 3.39, the probable error $r = 0.6745 \sigma$,

or probable error is proportional to standard deviation.

Hence we can write the probable error in X as

$$r_x = \sqrt{\left(\frac{\partial X}{\partial x_1}\right)^2 r_{x_1}^2 + \left(\frac{\partial X}{\partial x_2}\right)^2 r_{x_2}^2 + \dots + \left(\frac{\partial X}{\partial x_n}\right)^2 r_{x_n}^2} \quad \dots(3.58)$$

where r_{x_1}, r_{x_2} , etc. are the probable error in x_1, x_2 etc. The contribution of probable error of x_1 to the total error in X is $\left(\frac{\partial X}{\partial x_1}\right)^2 r_{x_1}^2$ and this contribution may be written in another form as r_{X1}^2 .

Therefore Eqn. 3.52 becomes $r_x = \sqrt{r_{X1}^2 + r_{X2}^2 + \dots + r_{Xn}^2}$... (3.59)

where the weighted probable error of x_n becomes as $r_{Xn} = \left(\frac{\partial X}{\partial x_n}\right)^2 r_{x_n}$... (3.60)

Example 3.16. We have a parallel circuit having two branches. The current in one branch is $I_1 = 100 \pm 2$ A and in the other is $I_2 = 200 \pm 5$ A. Determine the value of the total current $I = I_1 + I_2$.

- (a) considering the errors in I_1 and I_2 as limiting errors,
- and (b) considering the errors as standard deviations.

Comment upon the result.

Solution : (a) Now $I = I_1 + I_2$

$$\therefore \text{Fractional error in } I = \frac{\delta I}{I} = \pm \left(\frac{I_1}{I} \cdot \frac{\delta I_1}{I_1} + \frac{I_2}{I} \cdot \frac{\delta I_2}{I_2} \right)$$

but
$$\frac{\delta I_1}{I_1} = \frac{2}{100} = 0.02 \text{ and } \frac{\delta I_2}{I_2} = \frac{5}{100} = 0.025$$

Now
$$I = 200 + 100 = 300 \text{ A.}$$

Hence fractional error
$$\frac{\delta I}{I} = \pm \left(\frac{100}{300} \times 0.02 + \frac{200}{300} \times 0.025 \right) = \pm 0.0233$$

Hence I can be written as
$$I = 300(1 \pm 0.0233) = 300 \pm 7 \text{ A.}$$

(b) Now the errors are standard deviations.

Standard deviation of I
$$\sigma_I = \sqrt{\left(\frac{\partial I}{\partial I_1} \right)^2 \sigma_{I_1}^2 + \left(\frac{\partial I}{\partial I_2} \right)^2 \sigma_{I_2}^2} \quad (\text{See Eqn. 3.55})$$

$$= \sqrt{(2)^2 + (5)^2} = 5.38 \text{ A}$$

Since
$$\frac{\partial I}{\partial I_1} = \frac{\partial I}{\partial I_2} = 1$$

$$\therefore I = 300 \pm 5.38 \text{ A.}$$

Standard deviation in I expressed as a fraction is $5.38/300 = 0.018$

It is clear from above calculations that limiting errors of 2 per cent in I_1 and 2.5 per cent in I_2 combine in this case, to give a limiting error of 2.3 per cent in their sum I . While these very errors, when they are standard deviations, combine to give an error of only 1.8 per cent.

The use of standard deviation rather than limiting errors gives a more optimistic result. This is reasonable since the probability that both I_1 and I_2 are far from their respective means is small.

Example 3.17. A resistance is determined by voltmeter ammeter method. The voltmeter reads 100 V with a probable error of ± 12 V and ammeter reads 10 A with a probable error of ± 2 A. Determine the probable error in the computed value of resistance.

Solution : We have resistance
$$R = \frac{V}{I} = VI^{-1}.$$

\therefore Weighted probable error in the resistance due to voltage is,

$$r_{RV} = \frac{\partial R}{\partial V} r_V = I^{-1} r_V = \frac{r_V}{I} = \pm \frac{12}{10} = \pm 1.2 \Omega \quad (\text{See Eqn. 3.60})$$

Weighted probable error in resistance due to current

$$r_{RI} = \frac{\partial R}{\partial I} r_I = \frac{V}{I^2} r_I = \frac{100}{(10)^2} \times (\pm 2) = \pm 2 \Omega$$

From Eqn. 3.59, probable error in computed resistance is

$$r_R = \sqrt{(r_{RV})^2 + (r_{RI})^2} = \sqrt{(1.2)^2 + (2)^2} = 2.33 \Omega$$

Example 3.18. The law of deflection of a galvanometer is $I = K\theta/\cos \theta$, where I is the current; K a constant and θ is the deflection. If the angle of deflection θ is known to be within $\pm 0.1^\circ$ (standard deviation) of 15° , what is the percent standard deviation of current, I ?

Solution : Now
$$I = \frac{K\theta}{\cos \theta} = K\theta (\cos \theta)^{-1}$$

$$\therefore \frac{\partial I}{\partial \theta} = K[(\cos \theta)^{-1} + \theta(\cos \theta)^{-2} \sin \theta]$$

$$= K \left[\frac{1}{0.966} + \frac{\pi}{180} \times 15 \times \frac{1}{(0.966)^2} \times 0.258 \right] = 1.11 K.$$

Standard deviation of I is $\sigma_I = \frac{\partial I}{\partial \theta} \sigma_\theta = \pm (1.11 K) \left(0.1 \times \frac{\pi}{180} \right)$ rad

Percentage standard deviation of I is

$$= \frac{\sigma_I}{I} \times 100 = \pm \frac{(1.11 K)(0.1 \times \pi/180)}{K \times (\pi/180) \times 15 \times \cos 15^\circ} \times 100 = \pm 0.71\%.$$

3.14. Uncertainty Analysis and Treatment of Single Sample Data

Many a times the data available is a single sample data and therefore the statistical methods discussed earlier cannot be applied directly. On account of the single sample nature of the data, it is not possible to observe their scatter by plotting a frequency distribution curve. Hence, it becomes essential to modify our approach.

Kline and McClintock have proposed a method based upon probability and statistics which analyses the data employing **uncertainty distribution** rather than frequency distribution. They have defined the uncertainty distribution as the error distribution the experimenter believes would exist if the situation permits multi-sampling.

Kline and McClintock suggest that a single sample result may be expressed in terms of a **mean value** and an **uncertainty interval** based upon stated **odds**.

The result may be written as follows :

$$X = \bar{X} \pm w \quad (b \text{ to } 1) \quad \dots(3.61)$$

where \bar{X} = the value if only one reading is available on the arithmetic mean of several readings.

w = uncertainty interval.

b = odds, or the chance that the true value lies within the stated range, based upon the opinion of the experimenter.

The concept of **uncertainty** may be explained by the following example.

The results of a temperature measurement may be expressed as $T = 100^\circ\text{C} \pm 1^\circ\text{C}$

This means that there is an uncertainty of $\pm 1^\circ\text{C}$ in the result. In other words the experimenter is stating in precise terms the accuracy of results with which they have been made according to him. This brings about another dimension in measurements and that is, how far the experimenter is sure that his measurement falls within the specified limits. Therefore the need for a further specification arises. As mentioned earlier, Kline and McClintock proposed that the experimenter specify certain odds for the uncertainty. The aforesaid results may be given as

$$T = 100^\circ\text{C} \pm 1^\circ\text{C} \quad (20 \text{ to } 1)$$

Now the results expressed in the above form become more specific in nature. This is because the experimenter is willing to bet 20 to 1 odds that the temperature measurement which he has made are within $\pm 1^\circ\text{C}$ of 100°C .

This approach is of a particular value in setting up an experiment, especially when it involves expenses in terms of man-power, time, and equipment. It provides a basis for establishing basis for predetermined estimates of the reliability of results through a study of propagation of uncertainties (discussed below in Art. 3.14.1). In this way evaluation of the test results can be made even before the test is physically done.

3.14.1. Propagation of Uncertainties

The uncertainty analysis in measurements when many variates are involved is done on the same basis as is done for error analysis when the results are expressed as standard deviations or probable errors.

Suppose X is a function of several variables, $X=f(x_1, x_2, x_3, \dots, x_n)$ where $x_1, x_2, x_3, \dots, x_n$ are independent variables with the same degree of odds.

Let w_x be the resultant uncertainty and $w_{x_1}, w_{x_2}, w_{x_3}, \dots, w_{x_n}$ be the uncertainties in the independent variables $x_1, x_2, x_3, \dots, x_n$ respectively. The uncertainty in the result is given by :

$$w_x = \sqrt{\left(\frac{\partial X}{\partial x_1}\right)^2 w_{x_1}^2 + \left(\frac{\partial X}{\partial x_2}\right)^2 w_{x_2}^2 + \dots + \left(\frac{\partial X}{\partial x_n}\right)^2 w_{x_n}^2} \quad \dots(3.62)$$

Example 3.19. A certain resistor has a voltage drop of 110.2 V and a current of 5.3 A. The uncertainties in the measurements are ± 0.2 V and ± 0.06 A respectively. Calculate the power dissipated in the resistor and the uncertainty in power.

Solution : Power $P = \text{voltage} \times \text{current} = VI = 110.2 \times 5.3 = 584$ W

Now $P = VI$

$$\therefore \frac{\partial P}{\partial V} = I = 5.3 \text{ and } \frac{\partial P}{\partial I} = V = 110.2$$

$$w_V = \pm 0.2 \text{ and } w_I = \pm 0.06.$$

\therefore Uncertainty in power

$$\begin{aligned} &= \sqrt{\left(\frac{\partial P}{\partial V}\right)^2 w_V^2 + \left(\frac{\partial P}{\partial I}\right)^2 w_I^2} = \sqrt{(5.3)^2 \times (0.2)^2 + (110.2)^2 \times (0.06)^2} \\ &= \pm 6.7 \text{ W} = \pm \frac{6.7}{584} \times 100 = \pm 1.15\% \end{aligned}$$

Example 3.20. Two resistors R_1 and R_2 are connected in series and then in parallel. The values of resistances are :

$$R_1 = 100.0 \pm 0.1 \Omega, \quad R_2 = 50 \pm 0.03 \Omega$$

Calculate the uncertainty in the combined resistance for both series and parallel arrangements.

Solution : When the two resistances are connected in series the resultant resistance is :

$$R = R_1 + R_2$$

$$\therefore \frac{\partial R}{\partial R_1} = 1 \text{ and } \frac{\partial R}{\partial R_2} = 1$$

Hence uncertainty in the total resistance is

$$\begin{aligned} w_R &= \pm \sqrt{\left(\frac{\partial R}{\partial R_1}\right)^2 w_{R_1}^2 + \left(\frac{\partial R}{\partial R_2}\right)^2 w_{R_2}^2} \\ &= \pm \sqrt{(1)^2 \times (0.1)^2 + (1)^2 \times (0.03)^2} = \pm 0.1044 \Omega \end{aligned}$$

The total resistance is $R = 100 + 50 = 150 \Omega$

and can be expressed as $R = 150 \pm 0.1044 \Omega$.

When the two resistances are connected in parallel, the resultant resistance is :

$$R = \frac{R_1 R_2}{R_1 + R_2} = \frac{100 \times 50}{100 + 50} = 33.33 \Omega$$

Now $R = (R_1 R_2)(R_1 + R_2)^{-1}$

$$\begin{aligned} \therefore \frac{\partial R}{\partial R_1} &= (R_2)(R_1 + R_2)^{-1} - R_1 R_2 (R_1 + R_2)^{-2} \\ &= \frac{R_2}{R_1 + R_2} - \frac{R_1 R_2}{(R_1 + R_2)^2} = \frac{50}{150} - \frac{100 \times 50}{(150)^2} = 0.111 \\ \frac{\partial R}{\partial R_2} &= \frac{R_1}{R_1 + R_2} - \frac{R_1 R_2}{(R_1 + R_2)^2} = \frac{100}{150} - \frac{100 \times 50}{(150)^2} = 0.444. \end{aligned}$$

Hence uncertainty in total resistance is :

$$w_R = \pm \sqrt{\left(\frac{\partial R}{\partial R_1}\right)^2 w_{R_1}^2 + \left(\frac{\partial R}{\partial R_2}\right)^2 w_{R_2}^2}$$

$$= \pm \sqrt{(0.111)^2 \times (0.1)^2 + (0.444)^2 \times (0.03)^2} = 0.01734 \Omega.$$

The total resistance can be written as $R = 33.33 \pm 0.01734 \Omega$.

Example 3.21. A plot of land has measured dimensions of 50 by 150 m. The uncertainty in the 50 m dimension is ± 0.01 m. Calculate the uncertainty with which the 150 m dimension must be measured to ensure that the total uncertainty in the area is not greater than 150 per cent of that value it would have if 150 m dimension were exact.

Solution : Let

L = length of the plot = 150 m

B = width of the plot = 50 m

and A = area of the plot = $L \times B = 150 \times 50 = 7500 \text{ m}^2$.

Now $A = LB$

$$\therefore \frac{\partial A}{\partial L} = B \text{ and } \frac{\partial A}{\partial B} = L.$$

Uncertainty in area

$$w_A = \pm \sqrt{\left(\frac{\partial A}{\partial L}\right)^2 w_L^2 + \left(\frac{\partial A}{\partial B}\right)^2 w_B^2} = \pm \sqrt{B^2 w_L^2 + L^2 w_B^2}$$

Case I. When there is no uncertainty in measurement of L .

$$\therefore w_L = 0$$

Uncertainty in measurement of area

$$w_A = \pm \sqrt{B^2 w_L^2 + L^2 w_B^2} = \pm \sqrt{L^2 w_B^2} = \pm L w_B = 150 \times 0.01 = 1.5 \text{ m}^2.$$

Case II. When there is uncertainty in measurement of L .

The uncertainty in area is not to exceed $1.5 \times 1.5 = \pm 2.25 \text{ m}^2$.

$$w_A = \sqrt{B^2 w_L^2 + L^2 w_B^2}$$

$$\text{or } 2.25 = \sqrt{(50)^2 w_L^2 + (150)^2 (0.01)^2}$$

Hence uncertainty in measurement of L is $w_L = \pm 0.0335 \text{ m}$.

Example 3.22. A resistor has a nominal value of $10 \Omega \pm 0.1\%$. A voltage is applied across the resistor and the power consumed in the resistor is calculated in two ways :

(i) from $P = E^2/R$, and (ii) from $P = EI$.

Calculate the uncertainty in the power determination in each case when the measured values of E and I are :

$$E = 100 \text{ V} \pm 1\% \text{ and } I = 10 \text{ A} \pm 1\%$$

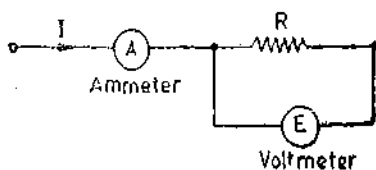

Fig. 3.6

Comment upon the result.

Solution : The circuit diagram is shown in Fig. 3.6.

$$(i) P = \frac{E^2}{R}$$

$$\therefore \frac{\partial P}{\partial E} = \frac{2E}{R} \text{ and } \frac{\partial P}{\partial R} = -\frac{E^2}{R^2}$$

Hence uncertainty in power measurement

$$w_p = \sqrt{\left(\frac{\partial P}{\partial E}\right)^2 w_E^2 + \left(\frac{\partial P}{\partial R}\right)^2 w_R^2} = \sqrt{\left(\frac{2E}{R}\right)^2 w_E^2 + \left(-\frac{E^2}{R^2}\right)^2 w_R^2}$$

∴ Percentage uncertainty in measurement of power is calculated by putting $P = E^2/R$.

$$\begin{aligned} \frac{w_p}{P} \times 100 &= \sqrt{4 \left(\frac{w_E}{E}\right)^2 + \left(\frac{w_R}{R}\right)^2} \times 100 \\ &= 4 \sqrt{(0.01)^2 + (0.01)^2} \times 100 = \pm 2.236\% \end{aligned}$$

(ii) $P = EI$

$$\frac{\partial P}{\partial E} = I \quad \text{and} \quad \frac{\partial P}{\partial I} = E.$$

Percentage uncertainty in power measurement

$$\begin{aligned} \frac{w_p}{P} \times 100 &= \sqrt{\left(\frac{\partial P}{\partial E}\right)^2 w_E^2 + \left(\frac{\partial P}{\partial I}\right)^2 w_I^2} \times 100 = \sqrt{I^2 w_E^2 + E^2 w_I^2} \times 100 \\ &= \sqrt{\left(\frac{w_E}{E}\right)^2 + \left(\frac{w_I}{I}\right)^2} \times 100 = \sqrt{(0.01)^2 + (0.01)^2} \times 100 = \pm 1.414\% \end{aligned}$$

The second method of power determination gives a much lower uncertainty than the first one even though the basic uncertainties in each quantity are the same. We conclude from here that a judicious selection of method of measurement is important in order to reduce the uncertainty in the final computed results.

UNSOLVED PROBLEMS

1. The value of a resistor is specified as $500 \Omega \pm 10\%$ by a manufacturer. Find the limits of resistance between which its value is guaranteed. [Ans. 450Ω to 550Ω]

2. The limiting errors for a four dial resistance box are :

Units... $\pm 0.2\%$

hundreds... 0.05%

Tens... $\pm 0.1\%$

thousands... $\pm 0.02\%$

If the resistance value is set at 3425Ω , calculate the limiting error in the resistance value. [Ans. $\pm 0.83 \Omega$]

3. A flowmeter is calibrated from 0 to $100 \text{ m}^3/\text{s}$. The accuracy is specified as within ± 0.75 per cent above 20 per cent of scale reading. What is the static error if the instrument indicates $80 \text{ m}^3/\text{s}$. [Ans. $\pm 0.6 \text{ m}^3/\text{s}$]

4. A 0.10 A ammeter has a guaranteed accuracy of 1.5 per cent of full scale reading. The current measured by this instrument is 2.5 A . Calculate the limiting values of current and the percentage limiting error. [Ans. $2.5 \pm 0.15 \text{ A}$; $\pm 6\%$]

5. A liquid flows through a pipe having a diameter of 100 mm with a velocity of 1 m/s . Calculate the rate flow. If the diameter is guaranteed within $\pm 1\%$ and the velocity is known to be within $\pm 3\%$ of measured value, find the limits within which rate of flow can be specified. [Ans. $7.85 \times 10^{-3} \text{ m}^3/\text{s} \pm 5\%$]

6. The resistance of an unknown resistor is determined by Wheatstone bridge. The solution for the unknown resistance is stated as

$$R_x = \frac{R_1 R_2}{R_3}$$

where limiting values of various resistances are

$$R_1 = 500 \Omega \pm 1\%, \quad R_2 = 615 \Omega \pm 1\%, \quad R_3 = 100 \pm 0.5\%$$

Calculate (a) the nominal value of the unknown resistor, (b) the limiting error of the unknown resistor in ohm, and (c) the limiting error in per cent of unknown resistor. [Ans. (a) 3075Ω , (b) $\pm 76.88 \Omega$ and (c) $\pm 2.5\%$]

7. Three resistors have the following ratings :

$$R_1 = 200 \Omega \pm 5\%, R_2 = 100 \Omega \pm 5\%, R_3 = 50 \Omega \pm 5\%.$$

Determine the magnitude of resultant resistance and the limiting errors in percentage and in ohm if the above resistances are connected in (a) series and (b) parallel. [Ans. (a) $350 \Omega \pm 5\%$, 17.5Ω (b) $28.6 \Omega \pm 5\%$, 1.30Ω]

8. The power factor of a circuit is determined by :

$$\cos \phi = \frac{P}{VI}$$

where P is the power in watt, V the voltage in volt and I is the current in ampere. The relative errors in power, current and voltage are respectively $\pm 5\%$, $\pm 1\%$ and $\pm 1\%$.

Calculate the relative error in power factor. Also calculate the uncertainty in the power factor if the errors were specified as uncertainties. [Ans. $\pm 2.5\%$, $\pm 1.5\%$]

9. A resistor is measured by the voltmeter-ammeter method. The voltmeter reading is 123.4 V on the 250 V scale and the ammeter reading is 283.5 mA on the 500 mA scale. Both meters are guaranteed to be accurate within ± 1 per cent of full scale reading. Calculate : (a) the indicated value of resistance, (b) the limits within which the result can be guaranteed. [Ans. $436 \Omega \pm 16.5 \Omega$]

10. The four arms of a Hay's a.c. bridge are arranged as follows :

AB is a coil of unknown impedance.

BC is a non-inductance $R_1 = 1000 \Omega$ with an error of ± 1 part in 10,000.

CD is a non-reactive resistor $R_2 = 833 \pm 0.25 \Omega$ in series with a no loss capacitor $C = 1.43 \pm 0.001 \mu\text{F}$.

DA is a non-reactive resistor $R_3 = 16800 \pm 1$ part in 10,000.

The supply frequency is $50 \pm 0.1 \text{ Hz}$. The bridge is balanced. Determine L and R of the coil and the limits of error. The balance conditions are :

$$L = \frac{CR_1R_3}{1 + \omega^2 C^2 R_3^2}$$

$$R = \frac{R_1R_2R_3C^2\omega^2}{1 + \omega^2 C^2 R_3^2}$$

[Ans. $L = 21 \pm 0.145 \text{ H}$; $R = 2480 \pm 29.5 \Omega$]

11. The stress in a mild steel flat circular diaphragm is given by :

$$s = \frac{3 D^3 p}{16 t^3} \text{ N/m}^2$$

where D = Diameter of the diaphragm ; mm,
 t = thickness of diaphragm walls ; m,
 and p = pressure applied ; N/m^2 .

A diaphragm has a diameter of 15 mm , thickness = 0.2 mm and the pressure applied is $300 \times 10^3 \text{ N/m}^2$. Calculate the stress. The known error in diameter is $+1\%$ and in thickness is 3% . Calculate the error in stress. [Ans. $316 \times 10^3 \text{ N/m}^2$, -4% , -12.64 N/m^2]

12. A set of independent ten measurements were made to determine the weight of a lead shot. The weights in gramme were :

1.570, 1.597, 1.591, 1.562, 1.577, 1.580, 1.564, 1.586, 1.550, 1.575.

Determine the (a) arithmetic mean, (b) average deviation (c) standard deviation (d) variance (e) probable error of one reading (f) problem error of the mean. [Ans. (a) 1.5752 g (b) 0.01068 (c) 0.01426 g (d) $2.0335 \times 10^4 \text{ g}^2$ (e) 0.0024 g (f) 0.00076 g]

13. The following values were obtained from the measurements of the value of a resistor : 147.2Ω , 147.4Ω , 147.9Ω , 148.1Ω , 147.1Ω , 147.5Ω , 147.6Ω , 147.4Ω , 147.6Ω and 147.5Ω . Calculate (a) arithmetic mean (b) average deviation (c) standard deviation, treating the data as finite (d) standard deviation treating the data as population. [Ans. (a) 147.55Ω (b) 0.22Ω (c) 0.295Ω (d) 0.28Ω]

14. The table given below lists a sample of experimental data :

Value	3	4	5	6	7	8	9	10	11
Frequency of occurrence	1	2	3	6	7	6	4	2	1

Calculate (a) arithmetic mean (b) mean deviation (c) standard deviation (d) probable error of one reading (e) the standard deviation and the probable error of the mean (f) standard deviation of standard deviation.

[Ans. (a) 7.062 (b) 1.45 (c) 1.865 (d) 1.258 (e) 0.33, 0.226 (f) 0.203]

15. A capacitor $C = 1.0 \pm 0.1 \mu\text{F}$ is charged to a voltage $20 \pm 1 \text{ V}$, where errors are probable errors. Find the charge on the capacitor and its probable error. [Ans. 20×10^{-6} coulomb, $\pm 2.2 \times 10^{-6}$ coulomb]

16. The resistance R of a copper wire is given by :

$$R = R_0[1 + \alpha(t - 20)]$$

where

$$R_0 = 4 \Omega \pm 0.2\%$$

is the resistance of the wire at 20°C . The value of resistance temperature co-efficient copper is $0.004 \Omega/\Omega^\circ\text{C} \pm 1\%$ and temperature $t = 25 \pm 1^\circ\text{C}$. Find the resistance R and its probable error. [Ans. $4.08 \Omega \pm 0.3\%$]

Units, Systems, Dimensions and Standards

4.1. Introduction

A considerable number of systems of Units have been used at various times during human history. Some systems are of historical interest only, some are of theoretical interest while others have been used in actual experimental work and have been found acceptable in some countries. However, there are some systems of units which have been accepted throughout the world. It is thus natural for us to acquaint ourselves with important and frequently used systems of units.

4.2. Unit

The result of a measurement of a physical quantity must be defined both in kind and magnitude. The standard measure of each kind of physical quantity is called a **Unit**. Measurement implies comparison with a standard value. For example, we can measure the numerical ratio (L_1/L_0) of a length L_1 to another length L_0 . Provided that L_0 is well defined, does not change with time and is readily reproducible to a high degree of accuracy, it can be chosen as a unit of length. In general, we can write :

$$(\text{Magnitude of a physical quantity}) = (\text{Numerical ratio}) \times (\text{Unit}) \quad \dots(4.1)$$

The **Numerical Ratio** is the number of times the unit occurs in any given amount of the same quantity and, therefore, is called the **number of measure**. The numerical ratio may be called **numerical multiplier** also. From Eqn. 4.1 it is clear that the process of measurement entails estimating the numerical ratio or the number of measure. Thus when we speak of a distance of 10 metre, we know that the metre is the unit of length and the number of units in the length is ten. The physical quantity, length, in this case, is defined by the unit, **metre**. The numerical ratio (or the number of measure) is 10 for this particular case. It should be understood that the numerical ratio has no physical meaning without the Unit. For example, if after measuring a quantity we simply write 10, then it may mean 10 metre, 10 second or 10 kilogramme etc. and hence is meaningless unless a unit is attached with it.

4.3. Absolute Units

An absolute system of units is defined as a system in which the various units are all expressed in terms of a small number of fundamental units. Absolute measurements do not compare the measured quantity with arbitrary units of the same type but are made in terms of **Fundamental Units**.

The word **absolute** should not be confused. In its long term usage in measurements, it has been associated with relating units to the units length, mass and time. However, sometimes it is given the connotation of perfection *i.e.*, no errors, deviations, or residuals exist in the system of measurement units.

4.4. Fundamental and Derived Units

When we measure a physical quantity, we must express the magnitude of that quantity in terms of a unit and a numerical multiplier (as explained in Art. 4.2). If we were concerned with measurement of only one quantity we could, if we wished, select for our unit any magnitude that seemed convenient to use. However, in measurements, we are concerned with a large number of quantities which are related to each other, through established physical equations, and, therefore, we cannot choose size of units of these quantities arbitrarily and independently. This way we can avoid

the use of awkward numerical constants when we express a quantity of one kind which we have derived from measurement of another quantity.

In any given piece of theoretical work the Units of the various quantities must all belong to a Consistent or coherent system.

In Science and Technology, two kinds of Units are used :

(i) Fundamental Units and (ii) Derived Units.

If we have A kinds of quantities to evaluate and B independent physical quantities expressing relationships between them we can independently choose sizes of units of $(A-B)$ quantities. The sizes of Units of remaining B quantities can be derived with the help of B physical equations. A system of Units so constructed is called a Consistent System. $(A-B)$ Units, which are independently chosen are called Fundamental Units. The remaining B Units are called Derived Units.

The Fundamental Units in mechanics are measures of length, mass, and time. The sizes of fundamental units, whether centimetre or metre or foot, gramme, or kilogramme or pound, second or hour, are quite arbitrary and can be selected to fit a certain set of circumstances. Since length, mass and time are fundamental to most other physical quantities besides those in mechanics, they are called the Primary Fundamental Units.

Measures of certain physical quantities in the thermal, electrical, illumination fields are also represented by fundamental units. These units are used only where these particular disciplines are involved and therefore they are called Auxiliary Fundamental Units.

All other units which can be expressed in terms of fundamental units with the help of physical equations are called Derived Units. Every derived unit originates from some physical law or equation which defines that unit. For example, the volume, V , of a room is equal to the product of its length l , width b , and height h . Therefore

$$V = lbh$$

If the metre is chosen as the unit of length, then the volume of a room $6 \text{ m} \times 4 \text{ m} \times 5 \text{ m}$ is 120 m^3 . Note that the number of measures ($6 \times 4 \times 5 = 120$) as well the units ($\text{m} \times \text{m} \times \text{m} = \text{m}^3$) are multiplied. The derived unit for volume is thus m^3 . Also note that use of an awkward numerical multiplier has been avoided.

4.5. Dimensions

Disregarding the problem of measurement and the concept of magnitude, it is evident that every quantity has a quality which distinguishes it from all other quantities. This unique quality is called Dimension. The dimension is written in a characteristics notation, as for example $[L]$ for length, $[T]$ for time and so on.

A derived unit is always recognized by its Dimensions, which can be defined as the complete algebraic formula for the derived unit. Thus when quantity such as area A of a rectangle is measured in terms of other quantities *i.e.* length, l , and width, b , in this case, the relationship is expressed mathematically as :

$$\text{Area } A = \text{a constant} \times l \times b \quad \dots(4.2)$$

Since l and b each have the dimensions of a length, written $[L]$, the dimensions of area are :

$$[A] = [L][L] = [L^2] \quad \dots(4.3)$$

Since the constant is a pure numerical ratio and is, therefore, dimensionless. As discussed earlier independent units for derived quantities like volume, area etc. are unnecessary and even inconvenient, for if we take, the constant in Eqn. 4.2 as unity, and if metre (m) is unit of length, metre square (m^2) can be used as unit for area.

As stated earlier, in mechanics the three fundamental units are length, mass and time. Their dimensional symbols are :

Length — [L]

Mass — [M]

Time— [T]

The square brackets indicate dimensional notation only. It should be understood that equality is in terms of dimensions only, and it should not be mixed up with numerical values.

4.6. Dimensions of Mechanical Quantities

All mechanical quantities can be expressed in terms of the three fundamental quantities—length, mass and time. A few examples are being given below :

1. Velocity	$= \frac{\text{length}}{\text{time}}$	$\therefore [v] = \frac{[L]}{[T]} = [LT^{-1}]$
2. Acceleration	$= \frac{\text{velocity}}{\text{time}}$	$\therefore [a] = \frac{[LT^{-1}]}{[T]} = [LT^{-2}]$
3. Force	$= \text{mass} \times \text{acceleration}$	$\therefore [F] = [M][LT^{-2}] = [MLT^{-2}]$
4. Work	$= \text{force} \times \text{distance}$	$\therefore [W] = [MLT^{-2}][L] = [ML^2T^{-2}]$
5. Power	$= \frac{\text{work}}{\text{time}}$	$\therefore [P] = \frac{[ML^2T^{-2}]}{[T]} = [ML^2T^{-3}]$
6. Energy	$= \text{power} \times \text{time}$	$[W] = [ML^2T^{-3}][T] = [ML^2T^{-2}]$
7. Momentum	$= \text{mass} \times \text{velocity}$	$= [M][LT^{-1}] = [MLT^{-1}]$
8. Torque	$= \text{force} \times \text{distance}$	$= [MLT^{-2}][L] = [ML^2T^{-2}]$
9. Stiffness	$= \frac{\text{torque}}{\text{angle}}$	$[K] = [ML^2T^{-2}]$
10. Surface Tension	$= \frac{\text{force}}{\text{length}}$	$[\sigma] = \frac{[MLT^{-2}]}{[L]} = [MT^{-2}]$
11. Dynamic Viscosity	$= \frac{\text{force}}{\text{area}} \cdot \frac{\text{velocity}}{\text{distance}}$	$[\mu] = \frac{[MLT^{-2}]}{[L^2]} \div \frac{[LT^{-1}]}{[L]} = [ML^{-1}T^{-1}]$

4.7. Historical Background of System of Units

For the primitive man, the length of his foot was an adequate standard to serve as the unit of length. The inch was a standard of length and was taken equal to the width of a man's thumb. But it was redefined, during the reign of Britain's King Edward I (1272)–1307 A.D., as equal to three barley corns, dry and round, laid end to end. A major milestone in the history of units is when Simon Stevin (1548–1620 A.D.) introduced the concept of decimal fractions as well as the idea of decimal system of units.

In 1790 A.D., the French revolutionary Government directed the French Academy of Sciences to submit proposals for a single system of weights and measures that would replace all the existing systems operating at that time. The French Scientists decided, as a first principle, that a Universal System of weights and measures should not depend upon the man made reference standards, but instead be based upon measurements provided by nature which are permanent. As a result of this judicious decision, the unit of length, metre, was chosen which is ten millionth part of the distance between north pole and south pole along the meridian passing through Paris; the unit of mass, they chose the mass of cubic centimetre of distilled water at 4°C and normal pressure (760 mm Hg) and called it gramme; third unit, the unit of time, they retained the traditional second, defining it as 1/86,400 part of mean solar day.

As a second principle, they decided that all other units should be derived from the aforementioned three fundamental units of length, mass and time. The third principle they proposed was that all multiples and submultiples of basic units be in the decimal system, and they devised the system of prefixes in use today.

The proposals of the French Academy were approved and introduced as the metric system of units in France in 1793. The metric system aroused considerable interest elsewhere and finally, in 1875, seventeen countries signed the so-called Metre Convention, making the metric system of units legal system. Since 1875, the international authority concerning metric units has been the Conference, Generale des Poids et Mesures (CGPM). The CGPM maintains the Bureau International des Poids et Mesures (BIPM) at Sevres near Paris. Britain and the United States, although signatories of the convention, recognized its legality only in international transactions but did not accept the metric system for their own domestic use.

Britain, in the meantime, had been working on a system of electrical units. The British Association for the advancement of Science appointed a Committee on Electrical Standards in 1861 under the Chairmanship of Clerk Maxwell. They decided on the centimetre and the gramme as the fundamental units of length and mass. From this developed the centimetre-gram-second or CGS absolute system of units.

4.8. CGS System of Units

Till now the most commonly used units in electrical work were CGS units. These units involve the use of unit of a fourth quantity in addition to units of mass, length, and time. Experimentally observed facts of either electrostatics or electromagnetism are used for defining CGS units for electrical work. Therefore, there are two systems of CGS units.

4.8.1. Electromagnetic Units (e.m. units). Units based on electromagnetic effects are known as electromagnetic units or e.m. units and the system is known as electromagnetic system of units or e.m.u. system. This system involves the units of four quantities; permeability (μ) of the medium and the units of length mass and time. The value of permeability of free space (vacuum) is taken as unity in this system.

4.8.2. Electrostatic Units (e.s. units). Units based on electrostatic effects are known as electrostatic units or e.s. units and the system is known as electrostatic system of units or e.s.u. system. This system involves the units of four quantities; permittivity (ϵ) of the medium and the units of length, mass and time. The value of permittivity of free space is taken as unity in this system.

The e.m.u. system is more convenient to use from the point of view of most electrical measurements, and is, much frequently used than the electrostatic system. If a quantity is expressed in C.G.S. system without any additional designation "electromagnetic" or "electrostatic" it may be taken that the electromagnetic system has been used.

4.9. Practical Units. Practical units are derived either from the absolute units or by reference to arbitrary standards. These units should be easy to handle and manage.

In working with either of the absolute systems mentioned above, some most commonly used units are found to be inconveniently large or small. The practical units employed are decimal multiples, or submultiples of the absolute electromagnetic units.

The practical units, based on e.m. units, are made larger or smaller than the corresponding e.m. units by an appropriate power of 10, to bring those which are mostly used in experimental work to convenient and manageable magnitudes.

The British Association Committee on electrical units decided that the practical unit of resistance (ohm) should be 10^9 C.G.S. electromagnetic units of resistance. It was also decided to make the practical unit of potential difference (volt) equal to 10^8 C.G.S. electromagnetic units of potential difference. These two magnitudes being fixed, we can fix the practical units of other quantities. For example, the practical unit of current (ampere) would be

$$\text{ampere} = \frac{\text{volt}}{\text{ohm}} = \frac{10^8 \text{ e.m. units}}{10^9 \text{ e.m. units}} = 10^{-1} \text{ e.m. unit.}$$

Thus the practical unit of current is 1/10 of a C.G.S. electromagnetic unit. Table 4.1 shows the symbols and magnitudes of practical units in terms of corresponding C.G.S. electromagnetic units of different quantities.

TABLE 4.1

No.	Quantity	Practical unit	Symbol	Number of C.G.S. e.m. units in one practical unit	Defining equation
1.	Charge	coulomb	Q	10^{-1}	$Q = I t$
2.	Current	ampere	I	10^{-1}	$E = I R$
3.	Potential Difference	volt	E	10^8	
4.	Resistance	ohm	R	10^9	
5.	Inductance	henry	L	10^9	$E = L \frac{dI}{dt}$
6.	Capacitance	farad	C	10^{-9}	$Q = CE$
7.	Power	watt	P	1 watt = 10^7 erg per second	
8.	Energy	joule	W	1 joule = 10^7 erg	

The sizes of practical units of resistance and potential difference were arbitrarily chosen to be of convenient magnitude and the other units are then derived from these units.

The practical unit of power is watt or joule per second and is equal to 10^7 ergs per second. The practical unit of energy is joule and is equal to 10^7 ergs. Actually in commercial measurement energy is expressed in kilowatt hour and one kilowatt hours is equal to 3.6×10^{13} ergs.

4.10. Dimensional Equations. All mechanical quantities can be represented in terms of the dimensions of length, mass and time, but electrical quantities need at least one other fundamental dimension.

4.11. Dimensions in Electrostatic System. In this system the dimension of permittivity ϵ is taken as the fundamental dimension. We use Coulomb's law as our starting point.

1. **Charge.** According to Coulomb's law, the force exerted between two charges Q_1 and Q_2 is

$$F = \frac{Q_1 Q_2}{\epsilon d^2}$$

where d is the distance between charges Q_1 and Q_2 . Putting the dimensions of force and distance, we have :

$$[MLT^{-2}] = \frac{[Q^2]}{[\epsilon][L^2]}$$

\therefore Dimensions of charge $[Q] = [\epsilon^{1/2} M^{1/2} L^{3/2} T^{-1}]$

2. **Current.** Current is charge per unit time.

Let $[I]$ represent the dimensions of current :

$$[I] = \frac{[Q]}{[T]} = \frac{[\epsilon^{1/2} M^{1/2} L^{3/2} T^{-1}]}{[T]} = [\epsilon^{1/2} M^{1/2} L^{3/2} T^{-2}]$$

3. **Potential Difference or Emf.** Potential difference is work done per unit charge.

$$\therefore [E] = \frac{[W]}{[Q]} = \frac{[ML^2T^{-2}]}{[\epsilon^{1/2}M^{1/2}L^{3/2}T^{-1}]} = [\epsilon^{-1/2}M^{1/2}L^{1/2}T^{-1}]$$

where $[E]$ and $[W]$ represent the dimensions of emf and work respectively.

4. Capacitance. Capacitance C is equal to $\frac{Q}{E}$.

$$\text{Therefore, dimensions of capacitance are } [C] = \frac{[Q]}{[E]} = \frac{[\epsilon^{1/2}M^{1/2}L^{3/2}T^{-1}]}{[\epsilon^{-1/2}M^{1/2}L^{1/2}T^{-1}]} = [\epsilon L]$$

5. Resistance. Resistance $R = \frac{\text{potential difference}}{\text{current}} = \frac{E}{I}$.

Therefore, dimensions of resistance are :

$$[R] = \frac{[E]}{[I]} = \frac{[\epsilon^{-1/2}M^{1/2}L^{1/2}T^{-1}]}{[\epsilon^{1/2}M^{1/2}L^{3/2}T^{-2}]} = [\epsilon^{-1}L^{-1}T]$$

6. Inductance. Inductance

$$L = \frac{\text{emf}}{\text{rate of change of current}} = \frac{e}{dl/dt}$$

\(\therefore\) Dimensions of inductance are :

$$[L] = \frac{[E]}{[I]/[T]} = \frac{[E][T]}{[I]} = \frac{[\epsilon^{-1/2}M^{1/2}L^{1/2}T^{-1}][T]}{[\epsilon^{1/2}M^{1/2}L^{3/2}T^{-2}]} = [\epsilon^{-1}L^{-1}T^2]$$

4.12. Dimensions in Electromagnetic System. The fourth dimension in this system is the dimension of permeability μ . The starting point is the law of force between poles.

1. Pole strength. Force $F = \frac{m_1 m_2}{\mu d^2}$

where d is the distance between poles of strengths m_1 and m_2 .

$$\therefore [MLT^{-2}] = \frac{[m^2]}{[\mu][L^2]}$$

Thus, dimensions of pole strength are $[m] = [\mu^{1/2}M^{1/2}L^{3/2}T^{-1}]$

2. Magnetizing force. Magnetizing force H is measured by force exerted on a unit pole. Therefore, dimensions of magnetizing force are :

$$[H] = \frac{[F]}{[m]} = \frac{[MLT^{-2}]}{[\mu^{1/2}M^{1/2}L^{3/2}T^{-1}]} = [\mu^{-1/2}M^{1/2}L^{-1/2}T^{-1}]$$

3. Current. We know that the magnetizing force at the centre of a loop of radius r is :

$$H = \frac{2\pi I}{r} \text{ if } I \text{ is in c.m. units.}$$

Putting the dimensions of H and r , we have $[\mu^{-1/2}M^{1/2}L^{-1/2}T^{-1}] = \frac{[I]}{[L]}$

\(\therefore\) Dimensions of current are $[I] = [\mu^{-1/2}M^{1/2}L^{1/2}T^{-1}]$

4. Charge. Charge = current \times time

\(\therefore\) The dimensions of charge are

$$[Q] = [I][T] = [\mu^{-1/2}M^{1/2}L^{1/2}T^{-1}][T] = [\mu^{-1/2}M^{1/2}L^{1/2}]$$

5. Potential difference. Potential difference is work done per unit charge. The dimensions of potential difference are

$$[E] = \frac{[W]}{[Q]} = \frac{[ML^2T^{-2}]}{[\mu^{-1/2}M^{1/2}L^{1/2}]} = [\mu^{1/2}M^{1/2}L^{3/2}T^{-2}]$$

6. Capacitance. The dimensions of capacitance are

$$[C] = \frac{[Q]}{[E]} = \frac{[\mu^{-1/2}M^{1/2}L^{1/2}]}{[\mu^{1/2}M^{1/2}L^{3/2}T^{-2}]} = [\mu^{-1}L^{-1}T^2]$$

7. Resistance. The dimensions of resistance are

$$[R] = \frac{[E]}{[I]} = \frac{[\mu^{1/2}M^{1/2}L^{3/2}T^{-2}]}{[\mu^{-1/2}M^{1/2}L^{1/2}T^{-1}]} = [\mu LT^{-1}]$$

8. Inductance. Inductance $L = \frac{E}{di/dt}$

Putting the dimensions of E , i and t , we have

$$[L] = \frac{[E]}{[i]/[t]} = \frac{[E][t]}{[i]} = \frac{[\mu^{1/2}M^{1/2}L^{3/2}T^{-2}][T]}{[\mu^{-1/2}M^{1/2}L^{1/2}T^{-1}]} = [\mu L]$$

Similarly the dimensions of other quantities can be found out.

4.13. Relationship between Electrostatic and Electromagnetic Systems of Units. We observe that two different dimensional equations are obtained for the same quantity. Any one quantity should have the same dimensions whatever may be the system. The dimensions of charge in e.m.u. system are

$$[Q] = [\mu^{-1/2}M^{1/2}L^{1/2}]$$

and in e.s.u. system are

$$[Q] = [\epsilon^{1/2}M^{1/2}L^{3/2}T^{-1}]$$

Equating the above two dimensions, $[\mu^{-1/2}M^{1/2}L^{1/2}] = [\epsilon^{1/2}M^{1/2}L^{3/2}T^{-1}]$
we have :

$$[\mu^{-1/2}\epsilon^{-1/2}] = [LT^{-1}].$$

Now dimensions $[LT^{-1}]$ are those of velocity,

$$\therefore \frac{1}{\sqrt{\mu\epsilon}} = \text{a velocity.}$$

Equating the dimensional equations of other quantities, we always get the same result i.e. some power of $\sqrt{\mu\epsilon}$ is always involved. It should be understood that it is not possible to obtain separate expressions for μ and ϵ .

In any system of units the permeability of free space μ_0 and permittivity of free space ϵ_0 are related by relation :

$$\mu_0\epsilon_0 = \frac{1}{v^2}$$

where v is the velocity of light in the system of units considered. For example, in C.G.S. units the value of v is nearly equal to 3×10^{10} which is the velocity light and of electromagnetic waves in free space. (The velocity of light is 3×10^{10} centimetre per second).

From the above relationship the dimensions of any electrical quantity can be converted from those of electrostatic system to those of the electromagnetic system, and vice versa.

For example, the dimensions of potential difference in e.s.u. system are

$$[E] = [\epsilon^{-1/2}M^{1/2}L^{1/2}T^{-1}]$$

and in e.m.u. system are $[E] = [\mu^{1/2}M^{1/2}L^{3/2}T^{-2}]$

$$\therefore \frac{1 \text{ e.s. unit of potential difference}}{1 \text{ e.m. unit of potential difference}} = \frac{[\epsilon^{-1/2} M^{1/2} L^{1/2} T^{-1}]}{[\mu^{1/2} M^{1/2} L^{3/2} T^{-2}]} = [\epsilon^{-1/2} \mu^{-1/2} L^{-1} T]$$

Now the units of length, mass and time are the same in both the systems. Therefore, dimensions L , M and T are neglected.

$$\therefore \frac{1 \text{ e.s. unit of potential difference}}{1 \text{ e.m. unit of potential difference}} = [\epsilon^{-1/2} \mu^{-1/2}] = 3 \times 10^{10} \text{ in C.G.S. system}$$

$$\therefore 1 \text{ e.s. unit of potential difference} = 3 \times 10^{10} \text{ e.m. units of potential difference} \\ = 3 \times 10^{10} \times 10^{-8} = 300 \text{ volt} \quad (\text{as } 1 \text{ volt} = 10^8 \text{ e.m. units of e.m.f.})$$

Similarly, 1 e.s. unit of capacitance

$$= \frac{1}{9 \times 10^{20}} \text{ e.m. units of capacitance} = \frac{1}{9 \times 10^{20}} \times 10^9 = \frac{1}{9 \times 10^{11}} \text{ farad}$$

or

$$1 \text{ farad} = 9 \times 10^{11} \text{ e.s. units of capacitance.}$$

Since the farad is too large a unit for many practical cases, the microfarad (μF) or pico-farad (pF) are used as more convenient units.

Similarly milli-henry or micro-henry are often used as more convenient units of inductance.

Table 4.2 shows the conversion factors for converting different e.m. units.

TABLE 4.2

Conversions of e.m.u. to e.s.u. and vice versa

No.	Quantity	Symbol	Dimensions		Number of e.m. units in one e.s. unit
			e.m.u.	e.s.u.	
1.	Charge	Q	$[\mu^{-1/2} M^{1/2} L^{1/2}]$	$[\epsilon^{1/2} M^{1/2} L^{3/2} T^{-1}]$	$\frac{1}{3 \times 10^{10}}$
2.	Current	I	$[\mu^{1/2} M^{1/2} L^{1/2} T^{-1}]$	$[\epsilon^{1/2} M^{1/2} L^{3/2} T^{-2}]$	$\frac{1}{3 \times 10^{10}}$
3.	Potential Difference	E	$[\mu^{-1/2} M^{1/2} L^{3/2} T^{-2}]$	$[\epsilon^{1/2} M^{1/2} L^{1/2} T^{-1}]$	3×10^{10}
4.	Resistance	R	$[\mu L T^{-1}]$	$[\epsilon^{-1} L^{-1} T]$	9×10^{20}
5.	Inductance	L	$[\mu L]$	$[\epsilon^{-1} L^{-1} T^2]$	9×10^{20}
6.	Capacitance	C	$[\mu^{-1} L^{-1} T^2]$	$[\epsilon L]$	$\frac{1}{9 \times 10^{20}}$

4.14: M.K.S. System (Giorgi System). The C.G.S. system suffers from the following disadvantages :

(i) There are two systems of units (e.m.u. and e.s.u.) for fundamental theoretical work and a third (practical units) for practical engineering work.

(ii) There are two sets of dimensional equations for the same quantity.

(iii) If we use C.G.S. system factor 4π occurs in formulae where its presence seems unwarranted specially in formulae which are widely used.

Owing to the above disadvantages it was thought to make modifications in the system. It was early recognized that the so called practical units themselves formed a coherent system and they could become an absolute system in terms of units of mass, length and time other than centimetre, gramme and second.

In 1901, Professor Giorgi introduced the M.K.S. system wherein metre, kilogramme and second were taken as the three fundamental mechanical units. In order to connect the electrical and mechanical quantities, a fourth fundamental quantity has to be used. This fourth quantity is usually permeability. The permeability of free space is taken as $\mu_0 = 10^{-7}$. The permeability μ of any other medium is given by $\mu = \mu_r \mu_0$ where μ_r is the relative permeability and has a value numerically equal to the permeability of medium when C.G.S. units are used. The permeability of free space in C.G.S. system is unity.

\therefore M.K.S. unit of permeability = $10^7 \times$ C.G.S. unit of permeability.

Now the greatest advantage of M.K.S. system of units is that if we take the three fundamental units as metre, kilogramme and second and the value of permeability of free space as 10^{-7} , then the magnitude of the six electrical units (charge, current, potential difference, resistance, inductance and capacitance) would be identical with their values in the practical system of units. Let us examine this.

1. **Charge.** The dimensions of charge in e.m.u. system are $[\mu^{-1/2} M^{1/2} L^{1/2}]$.

M.K.S. unit of length, metre = 100 centimetre = $100 \times$ C.G.S. unit of length.

M.K.S. unit of mass, kilogramme = 1000 gram = $1000 \times$ C.G.S. unit of mass.

M.K.S. unit of time, second = C.G.S. unit of time, second.

$$\therefore \frac{\text{M.K.S. unit of charge}}{\text{C.G.S. e.m. unit of charge}} = \left(\frac{10^7}{1}\right)^{-1/2} \left(\frac{1000}{1}\right)^{1/2} \left(\frac{100}{1}\right)^{1/2} = 10^{-1}$$

Thus M.K.S. unit of charge = 10^{-1} C.G.S. e.m. unit of charge.

But referring to Table 4'1, 10^{-1} C.G.S. e.m. unit of charge is equal to 1 practical unit of charge i.e., one coulomb.

\therefore M.K.S. unit of charge = practical unit of charge = 1 coulomb.

2. **Current.** The dimensions of current in e.m.u. system are $[\mu^{-1/2} M^{1/2} L^{1/2} T^{-1}]$.

$$\therefore \frac{\text{M.K.S. unit of current}}{\text{C.G.S. e.m. unit of current}} = \left(\frac{10^7}{1}\right)^{-1/2} \left(\frac{1000}{1}\right)^{1/2} \left(\frac{100}{1}\right)^{1/2} \left(\frac{1}{1}\right)^{-1} = 10^{-1}$$

Thus M.K.S. unit of current = $10^{-1} \times$ C.G.S. e.m. unit of current

= practical unit of current = 1 ampere.

3. **Potential difference (EMF).** The dimensions of potential difference are $[\mu^{1/2} M^{1/2} L^{3/2} T^{-2}]$.

$$\therefore \frac{\text{M.K.S. unit of emf}}{\text{C.G.S. e.m. unit of emf}} = \left(\frac{10^7}{1}\right)^{1/2} \left(\frac{1000}{1}\right)^{1/2} \left(\frac{100}{1}\right)^{3/2} \left(\frac{1}{1}\right)^{-2} = 10^8$$

i.e., M.K.S. unit of emf = $10^8 \times$ C.G.S. e.m. unit of emf = practical unit of emf = 1 volt.

4. **Resistance.** The dimensions of resistance are $[\mu L T^{-2}]$

$$\therefore \frac{\text{M.K.S. unit of resistance}}{\text{C.G.S. e.m. unit of resistance}} = \left(\frac{10^7}{1}\right) \left(\frac{100}{1}\right) \left(\frac{1}{1}\right)^{-1} = 10^9$$

M.K.S. unit of resistance = $10^9 \times$ C.G.S. e.m. units of resistance

= practical unit of resistance = 1 ohm.

5. **Inductance.** The dimensions of inductance are $[\mu L]$

$$\therefore \frac{\text{M.K.S. unit of inductance}}{\text{C.G.S. e.m. unit of inductance}} = \left(\frac{10^7}{1}\right) \left(\frac{100}{1}\right) = 10^9$$

M.K.S. system of inductance = $10^9 \times$ C.G.S. e.m. unit of inductance
= practical unit of inductance = 1 henry

6. Capacitance. The dimensions of capacitance are $[\mu^{-1}L^{-1}T^2]$

$$\therefore \frac{\text{M.K.S. unit of capacitance}}{\text{C.G.S. e.m. unit of capacitance}} = \left(\frac{10^7}{1}\right)^{-1} \left(\frac{100}{1}\right)^{-1} \left(\frac{1}{1}\right)^2 = 10^{-9}.$$

M.K.S. unit of capacitance = $10^{-9} \times$ C.G.S. e.m. units of capacitance
= practical unit of capacitance = 1 farad.

7. Power. The dimensions of power are $[ML^2T^{-3}]$

$$\therefore \frac{\text{M.K.S. unit of power}}{\text{C.G.S. e.m. unit of power}} = \left(\frac{1000}{1}\right) \left(\frac{100}{1}\right)^2 \left(\frac{1}{1}\right)^{-3} = 10^7.$$

M.K.S. unit of power = $10^7 \times$ C.G.S. e.m. units of power
= 10^7 ergs per second = practical unit of power = 1 watt.

8. Energy. The dimensions of energy are $[ML^2T^{-2}]$

$$\therefore \frac{\text{M.K.S. unit of energy}}{\text{C.G.S. e.m. unit of energy}} = \left(\frac{1000}{1}\right) \left(\frac{100}{1}\right)^2 \left(\frac{1}{1}\right)^{-2} = 10^7$$

M.K.S. unit of energy = $10^7 \times$ C.G.S. e.m. unit of energy
= 10^7 ergs = practical unit of energy = 1 joule.

Thus we see that the units of all purely electrical quantities in M.K.S. system, with units of power and energy, are identical with practical system of units comprising the ampere, volt, ohm, coulomb, farad, henry, watt, joule etc. Therefore, we conclude that if M.K.S. units are used throughout, the fundamental definitions of electrical quantities give the practical units directly, without any necessity of conversion factors.

M.K.S. unit of flux is 1 weber = 10^8 lines or maxwells.

M.K.S. unit of flux density is 1 weber per square metre = 10^4 gauss.

The advantages of M.K.S. system of units are :

(i) This system connects the practical units directly, with the fundamental laws of electricity and magnetism.

(ii) This system gives specified formulae for expressions of electromagnetism involving only practical units.

(iii) There are certain formulae in C.G.S. system wherein μ is frequently omitted owing to the permeability of air being unity. This absence of μ from the formulae wrongly indicates that the permeability of medium has no effect on the quantity being considered. In M.K.S. system the presence of μ in the expression emphasises the fact that the effect depends upon the medium. For

example the force per unit length between two straight conductors is $\frac{\mu I_1 I_2}{2\pi D}$ in the M.K.S. system.

This means that the formula makes it clear that the force is dependent upon the permeability of medium.

4.15. Rationalised M.K.S.A. System. The M.K.S. system in its rationalised form, utilizes four fundamental units. These are metre, kilogram, second and ampere. The use of ampere as a fourth fundamental unit has been recommended by International Electro-technical Commission in July 1950.

The dimensional equations for various quantities in terms of L , M , T and I are in Table 4.3.

There are many expressions in the M.K.S. system which contain the term 4π . This makes the formulae a little awkward to work with. Elimination of 4π from all the formulae is impossible but

the aim is to transfer the term 4π to formulae which are not very important or where it may be reasonably expected to occur as in volume of sphere. Thus rationalization means the elimination of term 4π from frequently used expressions by redefinition of certain units. This rationalization is carried out by assuming the value of permeability of free space as $4\pi \times 10^{-7}$ in place 10^{-7} as in the unrationalised system.

The basis of rationalization is the conception that unit flux issues from the surface of a body containing a unit charge. This flux is 4π in the case of unrationalized system. This fundamental change redefines all the relationships.

TABLE 43
Rationalised M.K.S. A. System

Sl. No.	Quantity	Symbol	Physical Equation	Dimensions
1.	Current	I		$[I]$
2.	Charge	Q	$Q = I t$	$[TI]$
3.	Emf	E	$E = \frac{\text{work done}}{\text{charge}}$	$[ML^2T^{-3}I^{-1}]$
4.	Resistance	R	$E = IR$	$[ML^2T^{-3}I^{-2}]$
5.	Flux (magnetic)	Φ	$E = N \frac{d\Phi}{dt}$	$[ML^2T^{-2}I^{-1}]$
6.	Flux Density	B	$B = \frac{\text{flux}}{\text{area}}$	$[MT^{-2}I^{-1}]$
7.	Mmf	\mathfrak{F}	$\mathfrak{F} = NI$	$[I]$
8.	Magnetizing force	H	$H = \frac{\text{mmf}}{\text{length}}$	$[L^{-1}I]$
9.	Reluctance	R	$R = \frac{\mathfrak{F}}{\Phi}$	$[M^{-1}L^{-2}I^2I^{-2}]$
10.	Inductance	L	$E = L \frac{dI}{dt}$	$[ML^2T^{-2}I^2]$
11.	Electric flux	ψ	$\psi = Q$	$[TI]$
12.	Electric flux density	D	$D = \frac{\text{electric flux}}{\text{area}}$	$[L^{-2}TI]$
13.	Electric field strength	ϵ	$\epsilon = \text{potential gradient}$	$[MLT^{-3}I^{-1}]$
14.	Capacitance	C	$C = \frac{Q}{E}$	$[M^{-1}L^{-2}T^4I^2]$

It should be emphasized again that rationalization does not mean elimination of 4π from all formulae but only from important formulae which are frequently used. The term 4π disappears in some relationships only to appear in another place in others. The advantage of rationalization is to be judged by its effects on the relationships which are considered very important.

4.16. SI Units. An international organization of which most of the advanced and developing countries, including India, are members, called the General Conference of Weights and Measures

TABLE 4.4

Base Units

<i>Unit</i>	<i>Name</i>	<i>Symbol</i>
Length	metre	m
Mass	kilogramme	kg
Time	second	s
Intensity of electric current	ampere	A
Thermodynamic temperature	kelvin	K
Luminous intensity	candela	cd
*Amount of substance	mole	mol

*According to British Standards Publication PD 5586 : 1972, the SI system is based on seven and not six base units. The seventh base unit is mole.

TABLE 4.5

Recommended Prefixes and Symbols

<i>Factor by which unit is multiplied</i>	<i>Prefix</i>	<i>Symbol</i>
10^{24}	Z.	Z
10^{12}	tera	T
10^9	giga	G
10^6	mega	M
10^4	myria	ma
10^3	kilo	k
10^2	hecto	h
10^1	deca	da
10^{-1}	deci	d
10^{-2}	centi	c
10^{-3}	milli	m
10^{-6}	micro	μ
10^{-9}	nano	n
10^{-12}	pico	p
10^{-15}	femto	f
10^{-18}	atto	a
10^{-24}	aus	

The recommended supplementary and derived units are indicated in Table 4.6.

(CGPM), has been entrusted with the task of prescribing definitions for fundamental units of weights and measures which are the very basis of Science and Technology today.

These definitions are adopted all over the world for purposes of science, technology, industry and commerce. The Eleventh General Conference of Weights and Measures which met in October, 1960 recommended a unified systematically constituted, coherent system of fundamental, supplementary and derived units for international use. This system, called the **International System of Units** and designated by the abbreviation, *SI System internationale d' units* is now legally compulsory in about twenty countries. It consists of six base units, two supplementary units and 27 derived units. Principles for the use of prefixes for forming the multiples and sub-multiples of units were also laid down. The six base units have already been adopted in the Standards of Weights and Measures Act, 1956. This Act is expected to be revised shortly to recognise all the SI units.

The subsequent General Conferences of Weights and Measures added more units to this system of units. Tables 4'4, 4'5 and 4'6, indicate the various units prefixes and their symbols which form the International System of Units.

TABLE 4'6
Supplementary and Derived Units

SUPPLEMENTARY UNITS			
1. Plane angle	radian		rad.
2. Solid angle	steradian		sr.
DERIVED UNITS			
1. Area	square metre	m^2	
2. Volume	cubic metre	m^3	
3. Frequency	hertz	Hz	1/s
4. Density (mass density)	kilogramme per cubic metre	kg/m^3	
5. Velocity	metre per second	m/s	
6. Angular velocity	rad per second	rad/s	
7. Acceleration	metre per second squared	m/s^2	
8. Angular acceleration	rad per second squared	rad/s^2	
9. Force	newton	N	$kg\ m/s^2$
10. Pressure (Mechanical Tension)	newton per square metre	N/m^2	
11. Dynamic viscosity	newton-second per square metre	m^2/s	
12. Kinematic viscosity	square metre per second	Ns/m^2	
13. Work, energy, quantity of heat	joule	J	Nm
14. Power	watt	W	J/s
15. Quantity of electricity	coulomb	C	As
16. Potential, potential difference, electromotive force	volt	V	W/A
17. Electric field strength	volt per metre	V/m	
18. Resistance	ohm	Ω	V/A
19. Capacitance	farad	F	As/V
20. Magnetic flux	wéber	Wb	Vs
21. Inductance	henry	H	Vs/A
22. Magnetic flux density	tesla	T	Wb/m^2
23. Magnetic field strength	ampere per metre	A/m	
24. Magnetomotive force	ampere	A	
25. Luminous flux	lumen	lm	cd, sr
26. Luminance	candela per square metre	cd/m^2	
27. Illuminance	lux	lx	lm/m^2

4.17. Base Units of SI

The seven base units which form the basis of the now universally accepted International Systems of Units, in their present status are defined below :

1. **Metre (m).** It is the unit of length. The metre is the length equal to 1,650,763.73 wavelengths in vacuum of radiation corresponding to the transition between the levels $2p_{10}$ and $5d_5$ (orange red line) of the krypton 86 atom (excited at the triple point of nitrogen, 63.15° kelvin).
2. **Kilogramme (kg).** It is the unit of mass. A kilogramme is equal to the mass of the international prototype of mass. This prototype is a cylinder of platinum iridium alloy.
3. **Second (s).** It is the unit of time. A second is defined as the duration of 9,192,631,770 periods of radiation corresponding to the transition between the two hyperfine levels of the ground state of the cesium 133 atom.
4. **Ampere (A).** It is the unit of electric current. The ampere is that constant current which, if maintained in two straight parallel conductors of infinite length, of negligible cross section, and placed one metre apart in vacuum, would produce between them a force equal to 2×10^{-7} newton per metre length.
5. **Kelvin (K).** It is the unit of temperature. The *kelvin, unit of thermodynamic temperature, is the fraction $1/273.16$ of the thermodynamic temperature of triple point of water.
6. **Candela (Cd).** It is the unit of luminous intensity. It is the luminous intensity, in a perpendicular direction, of a surface of $1/600,000$ square metre of a blackbody at the temperature of freezing platinum under a pressure of 101,325 newton per square metre.
7. **Mole (mol).** The mole is the amount of substance of a system which contains as many elementary entities as there are atoms in 0.012 kg of carbon 12. It should be noted that whenever mole is used, the elementary entities must be specified, and may be atoms, molecules, ions, electrons, other particles, or specified groups of such particles.

4.18. Supplementary Units

Two Supplementary units have been added to the basic six SI units. They are (i) radian for the plane angles, and (ii) steradian for the solid angles.

8. **Radian (rad).** Plane angle subtended by an arc of a circle equal in length to the radius of the circle.
9. **Steradian (sr).** Solid angle subtended at the centre of a sphere by the surface whose area is equal to the square of the radius of the sphere.

4.19. Multiplying Prefixes of Units

In the SI Units, the use of decimals, the use of powers of ten in preference to fractions simplifies any quantity. Presentation is further facilitated by the use of prefixes.

In a coherent system of units such as SI, the product or quotient of any two unit quantities becomes the unit of the resultant quantity without the introduction of any numerical factors, which is less prone to mistakes. In order to maintain coherent nature of the system, only SI units and not their multiples or sub-multiples be combined to form derived units. For stating value of a particular quantity, we may involve the use of factors of the form 10^n , where n is a positive or negative integer. Thus, to save writing space and to utilize time more effectively, a series of prefixes for Units has been evolved. A list of such prefixes is given in Table 4.5. The ones which in most general use are printed in bold type. Multiples or submultiples of 10^3 are the preferred prefixes, whereas the other multipliers tend to be a nuisance in calculations.

The basic unit of mass the gramme will often be used as an elementary unit (to avoid absurdity of using m kg) until such time when a new name is adopted for kilogramme.

The recommended multiple and submultiple units for the basic units are given in Table 4.7.

*The name kelvin (symbol °K) of the thermodynamic temperature was changed from degrees kelvin (symbol K) by the 13th Conference on Weights and Measures, Paris, Oct. 1967.

TABLE 4.7
Recommended Multiples and Submultiples of Basic Units

<i>Basic Unit</i>	<i>Recommended Multiple and Submultiple Units</i>						<i>Remarks</i>	
metre (m)	—	km	—	mm	μm	nm	—	μm is also called micron
kilogramme (kg)	Mg	—	g	mg	μg	—	—	Mg is called tonne
Second (s)	—	ks	—	ms	μs	ns	—	Use of min, hour and day is also allowed
ampere (A)	—	kA	—	mA	μA	nA	pA	
kelvin (K)	—	—	—	—	—	—	—	Multiples are not used.
Nominal unit multiplier	10 ⁶	10 ³	10 ⁰	10 ⁻³	10 ⁻⁶	10 ⁻⁹	10 ⁻¹²	

A selection of derived units is given in Table 4.8. Some of the units are given special names. The recommended multiples and submultiples are also given.

TABLE 4.8

<i>Derived Unit</i>	<i>Recommended Multiples and Submultiples</i>							
Force	—	—	kN	mN	μN	—	—	—
Work (and energy)	GJ	MJ	kJ	mJ	—	—	—	—
Power	GW	MW	kW	mW	μW	nW	pW	—
Pressure	GN/m ²	MN/m ²	kN/m ²	—	—	—	—	—
Velocity	—	—	km/s	—	—	—	—	—
Electrical potential	—	MV	kV	mV	μV	—	—	—
Electrical resistance	—	MΩ	kΩ	—	—	—	—	—
Nominal unit Multiplier	10 ⁹	10 ⁶	10 ³	10 ⁻³	10 ⁻⁶	10 ⁻⁹	10 ⁻¹²	—

There are many other units which are not part of SI but are recognised by International Committee for Weights and Measures. They are listed in Table 4.9.

TABLE 4.9

Quantity	Name of unit	Symbol	Definition
Time	minute	min	1 min = 60 s
	hour	h	1 h = 60 min = 3600 s
	day	d	1 d = 24 h
Plane angle	degree	°	1° = (π/180) rad
	minute	'	1' = (1/60)°
	second	"	1" = (1/60)' = (1/3600)°
Volume	litre	l	1 l = 1000 cm ³
Mass	tonne	t	1 t = 1000 kg
Pressure	pascal	Pa	1 Pa = 1 N/m ²
	bar	bar	1 bar = 10 ⁵ Pa

Example 4.1. If we adopt new units of voltage and current such that one new unit voltage = 100 volt and one new unit of current = 100 ampere, how would the units of resistance, capacitance, inductance be affected?

Solution: Let the old units of resistance, inductance, capacitance, voltage and current be R, L, C, E and I respectively and the new units of resistance, inductance, capacitance, voltage and current be R', L', C', E' , and I' respectively.

(i) We have resistance :

$$R = \frac{E}{I} \quad \text{and} \quad R' = \frac{E'}{I'} = \frac{100 E}{100 I} = \frac{E}{I} = R.$$

Thus the unit of resistance is equal to the old unit of resistance and, therefore, there is no change.

$$(ii) \text{ Inductance } L = \frac{E}{dI/dt} \quad \text{and} \quad L' = \frac{E'}{dI'/dt} = \frac{100 E}{100 dI/dt} = \frac{E}{dI/dt} = L.$$

Thus the new unit of inductance is equal to the old unit of inductance and, therefore, there is no change.

$$(iii) \text{ Capacitance } C = \frac{\text{charge}}{\text{emf}} = \frac{I t}{E} \quad \text{and} \quad C' = \frac{I' t}{E'} = \frac{100 I t}{100 E} = \frac{I t}{E} = C.$$

Thus the new unit of capacitance is equal to the old unit of capacitance and, therefore, there is no change.

Example 4.2. If we adopt new units of length, mass and time such that One new unit of length = 10 metre. One new unit of mass = 1/10 kilogram,

One new unit of time = 100 second.

How would the units of force, power, energy, and current be affected ?

The unit of permittivity remains the same.

Solution : (i) The dimensions of force are $[MLT^{-2}]$.

$$\therefore \text{New unit of force} = \left(\frac{1/10}{1}\right) \left(\frac{10}{1}\right) \left(\frac{1000}{1}\right)^{-2} = 10 \text{ old units of force} = 10 \text{ N.}$$

(ii) The dimensions of power are $[ML^2T^{-3}]$.

$$\therefore \text{New unit of power} = \left(\frac{1/10}{1}\right) \left(\frac{10}{1}\right)^2 \left(\frac{100}{1}\right)^{-3} = 10^{-5} \text{ old units of power} = 10^{-5} \text{ W.}$$

(iii) The dimensions of energy are $[ML^2T^{-2}]$.

$$\therefore \text{New unit of energy} = \left(\frac{1/10}{1}\right) \left(\frac{10}{1}\right)^2 \left(\frac{100}{1}\right)^{-2} = 10^{-3} \text{ old units of energy} = 10^{-3} \text{ J.}$$

(iv) The dimensions of current are $[\mu^{-1/2} M^{1/2} L^{1/2} T^{-1}]$.

$$\begin{aligned} \therefore \text{New unit of current} &= \left(\frac{1}{1}\right)^{-1/2} \left(\frac{1/10}{1}\right)^{1/2} \left(\frac{10}{1}\right)^{1/2} \left(\frac{100}{1}\right)^{-1} \\ &= 10^{-2} \text{ old units of current} = 10^{-2} \text{ A.} \end{aligned}$$

Example 4.3. Derive the dimensional equations for pole strength current, e.m.f., magnetic flux, magnetic flux density, m.m.f., magnetizing force, reluctance, permeance in the e.m. system of units.

Solution : (i) The force exerted between two poles is $F = \frac{m_1 m_2}{\mu d^2}$

$$\begin{aligned} \therefore \text{Dimensions of pole strength} &= [m] = [\text{force}]^{1/2} [\text{permeability}]^{1/2} [\text{distance}] \\ &= [MLT^{-2}]^{1/2} [\mu]^{1/2} [L] = [\mu^{1/2} M^{1/2} L^{3/2} T^{-1}] \end{aligned}$$

(ii) Force between two current carrying conductors is $F = \frac{\mu I_1 I_2 l}{2\pi d}$

\therefore Dimensions of current are :

$$[I] = [\text{force}]^{1/2} [\text{permeability}]^{-1/2} = [MLT^{-2}]^{1/2} [\mu]^{-1/2} = [\mu^{-1/2} M^{1/2} L^{1/2} T^{-1}]$$

(iii) Dimensions of e.m.f. are

$$[E] = \frac{[\text{power}]}{[\text{current}]} = \frac{[ML^2 T^{-3}]}{[\mu^{-1/2} M^{1/2} L^{1/2} T^{-1}]} = [\mu^{1/2} M^{1/2} L^{3/2} T^{-2}]$$

(iv) Emf = rate of change of flux linkages = $-N \frac{d\Phi}{dt}$

\therefore Dimensions of magnetic flux are :

$$[\Phi] = [E][T] = [\mu^{1/2} M^{1/2} L^{3/2} T^{-2}][T] = [\mu^{1/2} M^{1/2} L^{3/2} T^{-1}]$$

(v) Flux density = $\frac{\text{flux}}{\text{area}}$

\therefore Dimensions of flux density are :

$$[B] = \frac{[\Phi]}{[L^2]} = \frac{[\mu^{1/2} M^{1/2} L^{3/2} T^{-1}]}{[L^2]} = [\mu^{1/2} M^{1/2} L^{-1/2} T^{-1}]$$

(vi) Mmf = turns \times ampere

\therefore Dimensions of m.m.f. are $[F] = [I] = [\mu^{-1/2} M^{1/2} L^{1/2} T^{-1}]$

(vii) Magnetizing force = m.m.f. per unit length

$$\therefore [H] = \frac{[\mathcal{F}]}{[L]} = [\mu^{-1/2} M^{1/2} L^{-1/2} T^{-1}]$$

(viii) Reluctance = $\frac{\text{m.m.f.}}{\text{flux}}$

$$[R] = \frac{[\mathcal{F}]}{[\Phi]} = \frac{[\mu^{-1/2} M^{1/2} L^{1/2} T^{-1}]}{[\mu^{1/2} M^{1/2} L^{3/2} T^{-1}]} = [\mu^{-1} L^{-1}]$$

(ix) Permeance $\Lambda = \frac{1}{\text{reluctance}}$

$$\therefore [\Lambda] = [R]^{-1} = [\mu L]$$

Example 4.4. Derive the dimensions of (i) e.m.f., (ii) magnetic flux density, (iii) electric flux density, (iv) current density, (v) permeability, (vi) permittivity, (vii) resistivity and (viii) conductivity in L, M, T, I system of dimensions.

Solution : (i) $\text{Emf} = \frac{\text{work done}}{\text{charge}}$ $[E] = \frac{[ML^2T^{-2}]}{[IT]} = [I^{-1}ML^2T^{-3}]$

(ii) Magnetic flux density $B = \frac{\text{flux}}{\text{area}} = \frac{\Phi}{A}$

$\text{Emf} = \text{rate of change of flux linkages} = -N \frac{d\Phi}{dt}$

$$\therefore [B] = \frac{[\text{emf}] [\text{time}]}{[\text{area}]} = \frac{[I^{-1}ML^2T^{-3}][T]}{[L^2]} = [I^{-1}MT^{-2}]$$

(iii) Electric flux density = $\frac{\text{electric flux}}{\text{area}} = \frac{\text{charge}}{\text{area}}$

$$\therefore [D] = \frac{[IT]}{[L^2]} = [IL^{-2}T]$$

(iv) Current density = $\frac{\text{current}}{\text{area}}$ $\therefore [\mathcal{J}] = \frac{[I]}{[L^2]} = [IL^{-2}]$

(v) Flux = flux density \times area $\therefore [\Phi] = [I^{-1}MT^{-2}][L^2] = [I^{-1}ML^2T^{-2}]$

Mmf = turns \times current $\therefore [\mathcal{F}] = [I]$

Reluctance = $\frac{\text{mmf}}{\text{flux}}$ $\therefore [R] = \frac{[I]}{[I^{-1}ML^2T^{-2}]} = [I^2 M^{-1} L^{-2} T^2]$

We have, Reluctance = $\frac{\text{length}}{\text{permeability} \times \text{area}}$ $\therefore \text{Permeability} = \frac{\text{length}}{\text{reluctance} \times \text{area}}$

Thus, $[\mu] = \frac{[L]}{[I^2 M^{-1} L^{-2} T^2][L^2]} = [I^{-2} MLT^{-2}]$

(vi) Force = $\frac{Q_1 Q_2}{\epsilon d^2}$

$$\therefore [F] = \frac{[\text{Charge}^2]}{[\text{force}] [\text{distance}^2]} = \frac{[\text{current}^2] [\text{time}^2]}{[\text{force}] [\text{distance}^2]} = \frac{[I^2 T^2]}{[MLT^{-2}] [L^2]} = [I^2 M^{-1} L^{-3} T^4]$$

$$(vii) \quad \text{Resistance} = \frac{\text{emf}}{\text{current}}$$

$$[R] = \frac{[I^{-1} ML^2 T^{-3}]}{[I]} = [I^{-2} ML^2 T^{-3}]$$

$$\text{Resistance} = \frac{\text{resistivity} \times \text{length}}{\text{area}} \quad \therefore \quad [\text{Resistivity}] = \frac{[\text{resistance}] [\text{area}]}{[\text{length}]}$$

$$[\rho] = \frac{[I^{-2} ML^2 T^{-3}] [L^2]}{[L]} = [I^{-2} ML^3 T^{-3}]$$

$$(viii) \quad \text{Conductivity} = \frac{1}{\text{resistivity}}; \quad \therefore \quad [\sigma] = [\rho^{-1}] = [I^2 M^{-1} L^{-3} T^3]$$

Example 4'5. In deriving expression for resistance in Hay's bridge, following expression is obtained

$$R = \frac{\omega^2 R_1 R_2 R_3 C^2}{1 + \omega^2 C R_2^2}$$

where R, R_1, R_2, R_3 are resistances; C , a capacitance and $\omega = 2\pi f$, where f is frequency.

Find out whether the expression is dimensionally correct or incorrect. In case there is an error point out the term which needs correction.

Solution: The dimensions of various terms in e.m. system are

$$[\text{Resistance}] = [R] = [\mu L T^{-1}]$$

$$[\text{Capacitance}] = [C] = [\mu^{-1} L^{-1} T^2]$$

$$[\text{Angular velocity}] = [\omega] = [\text{Hz or cycles per second}] = [T^{-1}]$$

The left hand term is dimensionally expressed as $R = [\mu L T^{-1}]$ and the right hand term

$$\frac{\omega^2 R_1 R_2 R_3 C^2}{1 + \omega^2 C R_2^2} = \frac{[T^{-1}]^2 [\mu L T^{-1}] [\mu L T^{-1}] [\mu L T^{-1}] [\mu^{-1} L^{-1} T^2]^2}{1 + [T^{-1}]^2 [\mu^{-1} L^{-1} T^2] [\mu L T^{-1}]^2} = \frac{[\mu L T^{-1}]}{1 + [\mu L T^{-1}]^2}$$

This clearly shows that the dimensions of left hand and right hand terms do not balance and, therefore, the equation is dimensionally incorrect. The dimensions of left hand term are $[\mu L T^{-1}]$. The dimensions of the numerator of right hand term are $[\mu L T^{-1}]$ and in the denominator we have two terms i.e., 1 and $\omega^2 C R_2^2$. Now 1 is a dimensionless quantity and, therefore, in order that the dimensions of left hand term balance those of the right hand term, the denominator of right hand term should be dimensionless quantity. The dimensions of second term in the denominator are $[\mu L T^2]$ and in order that it may be a dimensionless quantity it should be multiplied with a term having dimensions of $[\mu^{-1} L^{-1} T^2]$ which are the dimensions of capacitance. Therefore, the second term in the denominator should contain another capacitance term or this term should be $(\omega^2 C R_2^2 \times C)$ or $\omega^2 C^2 R_2^2$. Therefore the correct equation is

$$R = \frac{\omega^2 R_1 R_2 R_3 C^2}{1 + \omega^2 C^2 R_2^2}$$

Example 4'6. In the course of a calculation an expression of the following form was arrived at

$$I = E \left\{ \frac{1}{Z_1} + \frac{j\omega M}{Z_2} \left(\frac{1}{R} + \frac{C}{L} \right) \right\}$$

Show that there must be an algebraical error, and point out the term or terms which require correction.

Solution: The dimensions of various quantities in e.m. system are

$$\begin{aligned}[\text{Current}] &= [I] = [\mu^{-1/2} L^{1/2} M^{1/2} T^{-1}] \\[\text{Emf}] &= [E] = [\mu^{-1/2} L^{3/2} M^{1/2} T^{-2}] \\[\text{Impedance}] &= [Z] = [\mu L T^{-1}] \\[\text{Mutual inductance}] &= [M] = [\mu L] \\[\text{Capacitance}] &= [C] = [\mu^{-1} L^{-1} T^2] \\[\text{Resistance}] &= [R] = [\mu L T^{-1}] \\[\text{Inductance}] &= [L] = \mu L.\end{aligned}$$

The left hand term is dimensionally expressed as : $[I] = [\mu^{-1/2} L^{1/2} M^{1/2} T^{-1}]$.

$$\text{The right hand term } E \left\{ \frac{1}{Z_1} + \frac{j\omega M}{Z_2} \left(\frac{1}{R} + \frac{C}{L} \right) \right\}$$

is dimensionally expressed as :

$$\begin{aligned}&= [\mu^{1/2} L^{3/2} M^{1/2} T^{-2}] \times \left\{ \frac{1}{[\mu L T^{-1}]} + \frac{[T^{-1}][\mu L]}{[\mu L T^{-1}]} \left(\frac{1}{[\mu L T^{-1}]} + \frac{[\mu^{-1} L^{-1} T^2]}{[\mu L]} \right) \right\} \\&= [\mu^{1/2} L^{3/2} M^{1/2} T^{-2}] \times \{ [\mu^{-1} L^{-1} T] + ([\mu^{-1} L^{-1} T] + [\mu^{-2} L^{-2} T^2]) \} \\&= \{ [\mu^{-1/2} L^{1/2} M^{1/2} T^{-1}] + [\mu^{-1/2} L^{1/2} M^{1/2} T^{-1}] + [\mu^{-3/2} L^{-1/2} M^{1/2} T^0] \}.\end{aligned}$$

In order that the two sides should balance dimensionally the dimensions of right hand side should be $[\mu^{-1/2} L^{1/2} M^{1/2} T^{-1}]$. We find that the dimensions of all the terms on the right hand side are not $[\mu^{-1/2} L^{1/2} M^{1/2} T^{-1}]$ and hence there is an algebraic error. The error is due to last term having dimensions of $[\mu^{-3/2} L^{-1/2} M^{1/2} T^0]$. The error can be eliminated if it has the dimensions $[\mu^{-1/2} L^{1/2} M^{1/2} T^{-1}]$. In order to achieve this we must multiply the last term by a quantity which has the dimensions

$$\frac{[\mu^{-1/2} L^{1/2} M^{1/2} T^{-1}]}{[\mu^{-3/2} L^{-1/2} M^{1/2} T^0]} = [\mu L T^{-1}].$$

But $[\mu L T^{-1}]$ are the dimensions of resistance or impedance.

Therefore, the last term of right hand side, C/L , should be multiplied by a term having the dimensions of either resistance or impedance.

Example 47. The expression for eddy current produced in a metallic former moving in the field of a permanent magnet is found as :

$$I_e = K \frac{B l b A}{(2b + l) \rho}$$

where

B = flux density,

l = length of former,

b = width of former

A = area of former,

ρ = resistivity of conducting former,

and

K = a constant.

It is suspected that the term angular frequency ω is missing. Use *LMTI* system for dimensional analysis to detect the error.

Solution : The dimensions of L.H.S. are equal to $[I]$

The dimensions of various quantities on R.H.S. are :

$$[B] = [M T^{-2} I^{-1}]$$

$$\begin{aligned} [L] &= [L] \\ [b] &= [L] \\ [A] &= [L^2] \\ \text{and} \quad [\rho] &= [ML^2T^{-3}I^{-2}] \end{aligned}$$

After substituting the dimensions of various quantities we have :

$$\text{R.H.S.} = \frac{[MT^{-2}I^{-1}][L][L][L^3]}{[L][ML^2T^{-3}I^{-2}]} = [T^{-1}I]$$

In order that the two sides are dimensionally correct the L.H.S. must be multiplied by a term having a dimension T^{-1} i.e. ω .

$$\therefore \text{The correct expression is } I_c = \frac{BibA\omega}{(2b+l)\rho}$$

Example 4.8. The expression for mean torque of an electro-dynamometer type of wattmeter may be written as :

$$T \propto M^p E^q Z^t$$

where M = mutual inductance between fixed and moving coils,
 E = applied voltage,
 Z = impedance of load circuit.

Determine the values of p, q, t from the dimensions of the quantities.

Solution. We have $T \propto M^p E^q Z^t$.

Therefore, we can write $T = KM^p E^q Z^t$

where K = a constant (a dimensionless quantity).

Writing the dimensions of various quantities

$$\text{Torque} = \frac{\text{power}}{\text{angular velocity}} \quad \therefore [T] = \frac{[ML^2T^{-3}]}{[T^{-1}]} = [ML^3T^{-2}]$$

$$\begin{aligned} [\text{Inductance}] &= [M] = [\mu L] \\ [\text{Emf}] &= [E] = [\mu^{1/2} M^{1/2} L^{3/2} T^{-2}] \\ [\text{Impedance}] &= [Z] = [\mu L T^{-1}]. \end{aligned}$$

Substituting the dimensions of various quantities in the expression for torque, we have

$$[ML^3T^{-2}] = [\mu L]^p [\mu^{1/2} M^{1/2} L^{3/2} T^{-2}]^q [\mu L T^{-1}]^t$$

$$\left[\mu^{p + \frac{q}{2} + t} M^{\frac{q}{2}} L^{p + \frac{3}{2}q + t} T^{-2q - t} \right]$$

In order that the two sides should balance dimensionally

$$\begin{aligned} p + \frac{q}{2} + t &= 0, & \frac{q}{2} &= 1, \\ p + \frac{3}{2}q + t &= 2, & \text{and } -2q - t &= -2 \end{aligned}$$

From above $q=2$ $t=-2$ $p=1$

Therefore, the equation is $T \propto ME^2Z^{-2} \propto \frac{ME^2}{Z^2}$.

Example 4.9. The energy stored in a parallel plate capacitor per unit volume is given by :

$$W = K\epsilon^a V^b d^c$$

where ϵ = permittivity of medium,

d = distance between plates,

V = voltage between plates,

and K = a constant.

Find the values of a , b and c .

Solution : Writing the dimensions of various quantities in e.m. system :

$$W = \frac{\text{energy}}{\text{volume}}$$

$$\therefore [W] = \frac{[ML^2T^{-2}]}{[L^3]} = [ML^{-1}T^{-2}]$$

$$[\epsilon] = [\mu^{-1}L^{-2}T^2] \text{ as } \mu\epsilon = 1/v^2$$

$$[V] = [\mu^{1/2}M^{1/2}L^{3/2}T^{-2}]$$

and $[d] = [L]$

$$\text{we get } [ML^{-1}T^{-2}] = [\mu^{-1}L^{-2}T^2]^a [\mu^{1/2}M^{1/2}L^{3/2}T^{-2}]^b [L]^c$$

$$\text{or } [\mu^0 ML^{-1}T^{-2}] = [\mu]^{-a+b/2} [M]^{b/2} [L]^{-2a+3/2b+c} [T]^{2a-2b}$$

Balancing the dimensions on both sides

$$-a + \frac{1}{2}b = 0, \quad \frac{b}{2} = 1$$

$$-2a + \frac{3}{2}b + c = -1 \quad \text{and} \quad 2a - 2b = -2.$$

From above we get $a=1$, $b=2$ and $c=-2$

Hence, energy stored per unit volume is :

$$W = K\epsilon V^2 d^{-2} = \frac{K\epsilon V^2}{d^2}.$$

Example 4.10. The expression for eddy current loss W per metre length of wire may be written as

$$W \propto f^a B_m^b d^c \rho^g$$

where f = frequency in Hz,

B_m = maximum flux density,

d = diameter of wire,

ρ = resistivity of material,

and a , b , c and g are constants.

Determine the values of a , b , c , g from the dimensions of quantities involved. Length L , mass M , time T and current I may be taken as fundamental quantities. Derive the dimensions of each quantity from fundamentals. Do not reproduce the dimensions from memory.

Solution. We can write the expression as $W = Kf^a B_m^b d^c \rho^g$

where K = a constant and a dimensionless quantity.

We now derive the dimensional expressions for the quantities involved.

$$W = \text{power loss per unit length}$$

$$\therefore [W] = \frac{[ML^2T^{-3}]}{[L]} = [MLT^{-3}]$$

$$f = \text{frequency in Hz (cycles per second)} \quad \therefore [f] = [T^{-1}]$$

Charge = current \times time

$$\therefore [Q] = [I][T] = [IT], \quad \text{Emf} = \frac{\text{work done}}{\text{charge}}$$

$$\therefore [E] = \frac{[ML^2T^{-2}]}{[Q]} = \frac{[ML^2T^{-2}]}{[IT]} [I^{-1}ML^2T^{-3}]$$

$$\text{Emf} = \text{turns} \times \text{rate of change of flux} \quad \therefore [\text{Flux}] = [\text{emf}][\text{time}]$$

$$[\Phi] = [I^{-1}ML^2T^{-3}][T] = [I^{-1}ML^2T^{-2}]$$

$$\text{Flux density} = \frac{\text{flux}}{\text{area}}$$

$$\therefore [B_m] = \frac{[\Phi]}{[L^2]} = \frac{[I^{-1}ML^2T^{-2}]}{[L^2]} = [I^{-1}MT^{-2}]$$

$$\text{We have } [\text{Diameter}] = [\text{length}] \quad \therefore [d] = [L]$$

$$\text{Resistance} = \frac{\text{emf}}{\text{current}}$$

$$\therefore [R] = \frac{[I^{-1}ML^2T^{-3}]}{[I]} = [I^{-2}ML^2T^{-3}]$$

$$\text{Resistance} = \frac{\text{resistivity} \times \text{length}}{\text{area}} \quad \text{or} \quad \text{resistivity} = \frac{\text{resistance} \times \text{area}}{\text{length}}$$

$$\therefore [\rho] = \frac{[R][L^2]}{[L]} = \frac{[I^{-2}ML^2T^{-3}][L^2]}{[L]} = [I^{-2}ML^3T^{-3}]$$

Substituting the dimensions of quantities involved in the expression for loss per unit length

$$[MLT^{-3}] = [T^{-1}]^a [I^{-1}MT^{-2}]^b [L]^c [I^{-2}ML^3T^{-3}]^d = [I^{-b-2d} M^{b+d} L^{c+3d} T^{-a-2b-3d}]$$

For dimensional balance, we must equate the corresponding indices. Therefore,

$$-b - 2d = 0$$

$$b + d = 1$$

$$c + 3d = 1$$

$$-a - 2b - 3d = -3$$

\therefore We have, from above, $g = -1$, $b = 2$, $c = 4$, and $a = 2$.

$$\text{Hence the expression is } W \propto f^2 B_m^2 d^4 \rho^{-1} \propto \frac{f^2 B_m^2 d^4}{\rho}$$

4.20. Determination of Absolute Units. In order to establish a satisfactory system of measurements we must determine the absolute values of electrical quantities. Determination of absolute values involves the measurement of a unit in terms of physical quantities which are measured practically. Thus if we can determine the units of, say, current and emf by practical measurements, standards for all other electrical quantities like resistance etc. can be set up in terms of current and emf.

The determination of absolute unit of emf involves the measurement of energy which is difficult to measure and, therefore, the determination of absolute unit of emf is not usually attempted. The practice is to determine the absolute units of current and resistance and to express the units of

all other quantities in terms of these two quantities. Actually it may be desirable to have, in addition, primary standards of inductance and capacitance, as values of these standards involve only physical dimensions (It is clear from the fact that the dimensions of inductance are $[\mu L]$ in e.m. system and those of capacitance are $[\epsilon L]$ in e.s. system).

4.21. Absolute Measurement of Current. The dimensions of current are $[\mu^{1/2} M^{1/2} L^{1/2} T^{-1}]$ or $[M^{1/2} L^{1/2} T^{-1}]$ if we regard permeability as a non-dimensional quantity. The dimensions of (current)² are $[MLT^{-2}]$ which are the dimensions of force. Therefore, the absolute measurement of current involves the measurement of a force. This force may be exerted in two ways :

(i) By the current in a solenoid upon a suspended magnetic needle—as in a tangent or sine galvanometer.

(ii) By the current in one part of a circuit upon another part of the circuit in series with it, and carrying the same current as in a current balance.

The absolute measurement of current by **Rayleigh's Current Balance** is described below :

4.21.1. Rayleigh's Current Balance. This instrument works on the principle that if a current carrying coil is placed with its plane parallel to that of another current carrying coil with their axes coincident, there will be a force exerted between the coils. This force is proportional to the product of currents in the two coils and if the coils carry the same current, the force is proportional to the square of the current. This force can be measured if one of the coils is movable and is suspended. In this case the force can be weighed.

Fig 4.1 shows the arrangement of coils in a Rayleigh's current balance. There are two fixed coils and a small moving coil which is suspended from the arm of a sensitive balance. The three coils are connected in series. If I is the value of current through them the force F exerted on the suspended coil is :

$$F = I^2 \frac{dM}{dx} \text{ newton}$$

where $\frac{dM}{dx}$ is the rate of change of mutual inductance between the fixed and moving coils. This is

expressed in henry/metre. A value of $\frac{dM}{dx}$ can be obtained from the physical dimensions of the coils and

F is purely a mechanical quantity which can be accurately measured by the balance. Thus the value of I is dependent upon units of purely physical mechanical quantities and is independent of other electrical units. For measuring the value F , it is usual to counterbalance the suspended coil when the force on it is upwards. The current through the suspended coil is only reversed thus reversing the

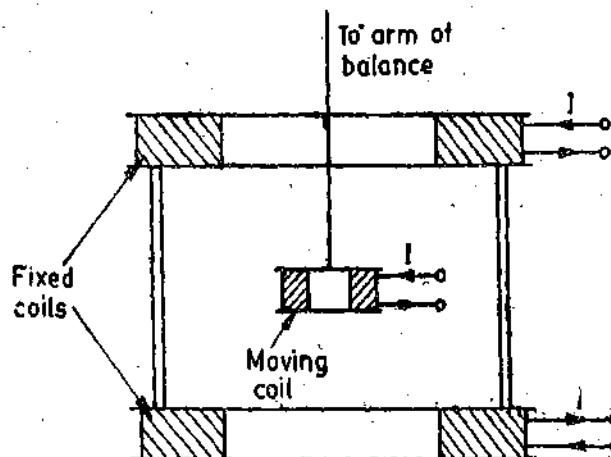

Fig. 4.1. Rayleigh's current balance:

force. The additional counterbalance weight gives the value $2F$. It should be noted that the expression for the force is in newton and since the weights used in counterbalancing the force are in kg, the value of 'g' acceleration due to gravity must be known. The accuracy with which the value of 'g' is known will determine the accuracy of current measurement. In the above measurement, we must try to minimize the errors due to :

(i) Inaccuracy in values of physical dimensions of the coils (on which the value of mutual inductance M depends).

(ii) Pull on the moving system due to leads attached to movable coil. The leads used should be flexible.

(iii) Heating of coils : The fixed coils should be cooled by water jackets and the moving coil by water chamber.

(iv) Distortion of magnetic field : For this bobbins made of non-magnetic materials should be used.

4.22. Absolute Measurement of Resistance. The resistance has the dimensions $[\mu LT^{-1}]$ in the e.m. system of units. Taking the permeability as dimensionless, the dimensions of resistance are $[LT^{-1}]$ i.e., those of velocity. Thus the absolute measurement of resistance involves the measurement of either a velocity or the measurement of length and time. We describe here the Lorenz method of absolute measurement of resistance.

4.22.1. Lorenz Method. Fig. 4.2 shows the experimental set up used for this method.

There is a circular metallic disc which is mounted concentrically inside a solenoid. The disc is rotated at a uniform speed. A steady current is passed through the solenoid. R is a low resistance whose absolute value is to be determined. The resistance R is connected across the disc with the help of leads and two brushes. One brush presses the edge of the disc and the other brush makes a contact with the disc near its centre. A sensitive galvanometer G is included in one of the leads. The magnetising current I for the solenoid is supplied by a battery. This current passes through resistance R also.

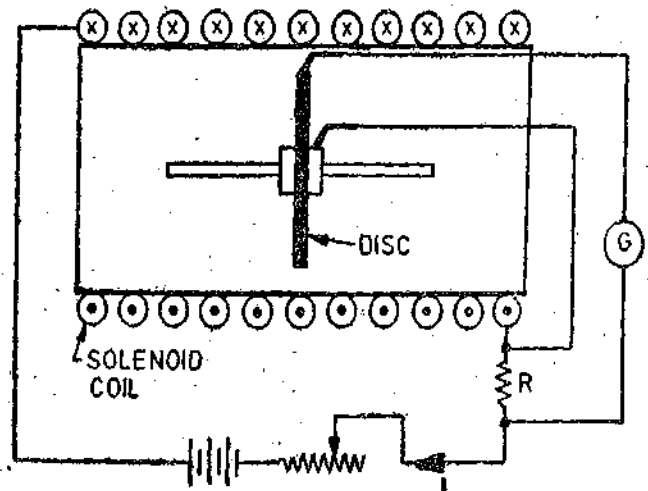

Fig. 4.2. Lorenz Method.

When we pass current through the solenoid, it produces a magnetic field. As the disc rotates an emf is induced in it. The current flowing through R produces a voltage drop across it. The emf generated in the disc is balanced against the voltage drop in resistance R , the balance being indicated by the galvanometer G . The speed of the disc is adjusted till a balance is obtained.

Let M = mutual inductance between disc and solenoid in henry. Inductance is defined as flux linkages per unit current and therefore the value of magnetic flux linkages produced by the disc when a current of I ampere passes through solenoid is MI .

But flux linkages of disc = number of turns \times flux linking = flux linking
(as the number of turns in a disc is one).

Therefore, we conclude that the value of flux passing perpendicularly through the disc surface is MI weber if a current I ampere passes through the solenoid.

Let n = speed of the disc in r.p.s. when the deflection of galvanometer is zero.

\therefore Emf induced in the disc = rate of change of flux linkages

$$= MI \times n = MIn \text{ volt.}$$

Voltage drop in resistance = IR volt

where I and R are expressed in ampere and ohm respectively.

Thus when the deflection of the galvanometer is zero,

$$MIn = IR \quad \text{or} \quad R = Mn \text{ ohm.}$$

The value of mutual inductance M is obtained from the physical dimensions of the solenoid and the disc. Hence the value of resistance R is determined solely in terms of linear dimensions of solenoid and disc, number of turns of solenoid and speed of rotation and is thus independent of other electrical units.

The apparatus used involves several sophisticated modifications in the construction, but the basic principle remains the same as described.

We can obtain very accurate results, if

- (i) Disc and solenoid are carefully constructed and their dimensions are accurately measured.
- (ii) The effect of earth's magnetic field upon the emf induced is made small. This is done by arranging the plane of the disc to be in the magnetic meridian and making two measurements one with current reversed.
- (iii) The thermoelectric emfs are eliminated.
- (iv) The speed of rotation is accurately determined. The speed be determined by stroboscopic methods or with the help of directly driven chronograph.

Example 4.11. In a simple form of Lorenz apparatus for absolute measurement of resistance, the solenoid is 50 mm in diameter and 0.5 m long. It is uniformly wound with 8000 turns of wire. The rotating copper disc is 40 mm in diameter and the galvanometer indicates balance condition when the speed of the disc is 5952 r.p.m. Calculate the value of resistance in ohm and the mutual inductance between the disc and the coil in henry.

Solution : Number of turns $N = 8000$.

Length of solenoid $l = 0.5 \text{ m.}$

Radius of solenoid $r = 25 \text{ mm} = 0.025 \text{ m.}$

$$\text{Intensity of field at the centre} = H = \frac{NI}{2\sqrt{(l/2)^2 + r^2}}$$

$$\text{Flux density at the centre } B = \mu_0 H = \frac{\mu_0 NI}{2\sqrt{(l/2)^2 + r^2}}$$

Let r_1 be the radius of disc. \therefore Flux linked by disc $\Phi = B \times \text{area of disc}$

$$\text{or} \quad \Phi = \frac{\mu_0 NI}{\sqrt{(l/2)^2 + r^2}} \times \pi r_1^2 = \frac{\pi \mu_0 r_1^2 NI}{2\sqrt{(l/2)^2 + r^2}}$$

The disc is treated as a single turn winding.

$$\therefore \text{ Flux linkages of disc } \psi = \frac{\pi \mu_0 r_1^2 NI}{2\sqrt{(l/2)^2 + r^2}}$$

Mutual inductance between disc and solenoid

$$M = \frac{\psi}{I} = \frac{\pi \mu_0 r_1^2 N}{2\sqrt{(l/2)^2 + r^2}} = \frac{\pi \times 4\pi \times 10^{-7} \times (0.02)^2 \times 8000}{2\sqrt{\left(\frac{0.5}{2}\right)^2 + (0.025)^2}} \text{ H} = 0.256 \text{ mH.}$$

$$\text{Speed of disc } n = \frac{5952}{60} \text{ r.p.s.}$$

$$\text{Resistance } R = Mn = 0.256 \times 10^{-3} \times \frac{5952}{60} = 0.02493 \text{ } \Omega.$$

4'23. Standards and their Classification

A standard is a physical representation of a unit of measurement. The term 'standard' is applied to a piece of equipment having a known measure of physical quantity. They are used for the purpose of obtaining the values of the physical properties of other equipment by comparison methods. In fact, a unit is realized by reference to a material standard or to a natural phenomenon including physical and atomic constants. For example, the fundamental unit of mass in the metric system (SI) is the kilogramme, defined as the mass of the cubic decimetre of water at its temperature of maximum density of 4°C. This unit of mass is represented by a material standard: the mass of the International Prototype kilogramme consisting of platinum-iridium hollow cylinder. This unit is preserved at the International Bureau of Weights and Measures at Sevres, near Paris and is the material representation of the kilogramme. Similar standards have been developed for other units of measurement, including fundamental units as well as for some of the derived mechanical and electrical units.

Just as there are fundamental and derived units of measurement we find different types of "Standards of Measurement" classified by their function and application in the following categories :

- | | |
|------------------------------|-------------------------|
| (i) International standards. | (ii) Primary standards |
| (iii) Secondary standards. | (iv) Working standards. |

4'23'1. International Standards

The international standards are defined on the basis of international agreement. They represent the units of measurements which are closest to the possible accuracy attainable with present day technological and scientific methods. International standards are checked and evaluated regularly against *absolute measurements* in terms of the fundamental units. The International Standards are maintained at the International Bureau of Weights and Measures and are not available to the ordinary user of measuring instruments for the purposes of calibration or comparison.

1. International Ohm. It is defined as the resistance offered to the passage of an in-varying current by a column of mercury at the temperature of melting ice, of mass 14'4521 gm of uniform cross-sectional area and length 106'300 cm.

International Ampere. It is the unvarying current which, when passed through a solution of silver nitrate in water (prepared in accordance with stipulated specifications) deposits silver at the rate of 0'00111800 gm per second.

Improvements in the accuracy of absolute measurements have made the International units superfluous and they have been replaced by absolute units. One of the main reasons for adopting an absolute system of units is that now wire resistance standards can be constructed which are sufficiently permanent and do not vary appreciably with time.

Absolute Units. In 1948 the International ampere was superseded by the absolute ampere. The determination of absolute ampere was again made by means of a current balance, which weighs the force between two current carrying coils. Improvement in the techniques of force measurement yields a value for ampere far superior than given by early measurements. The relationship between the force and the current which produces the force can be calculated from fundamental electromagnetic theory concepts. It reduces to a simple computation involving the geometric dimensions of the coils. The absolute ampere is now the fundamental unit of electric current in the SI.

The magnitudes of the International units differ slightly from those of absolute units although differences are very small. The accuracy of measurements differs but most accurate observations made in U.K. lead to the following values of International units in terms of absolute units.

- 1 International ohm = 1'00049 absolute ohm.
- 1 International ampere = 0'99985 absolute ampere.

4'23'2. Primary Standards

Primary standards are absolute standards of such high accuracy that they can be used as the

ultimate reference standards. These standards are maintained by national standards laboratories in different parts of the world. The primary standards, which represent the fundamental units and some of the derived electrical and mechanical units, are independently calibrated by absolute measurements at each of the national laboratories. The results of these measurements are compared against each other, leading to a world average figure for the primary standards. Primary standards are not available for use outside the national laboratories. One of the main functions of the primary standards is the verifications and calibration of secondary standards.

The primary standards are few in number. They must have the highest possible accuracy. Also these standards must have the highest stability, *i.e.*, their values should vary as small as possible over long periods of time even if there are environmental and other changes. The following points must be taken into serious consideration when a primary standard is built :

- (i) The materials should have a long time stability.
- (ii) The temperature co-efficient of the materials should be as small as possible.
- (iii) The deterioration of the materials caused by moisture and other environmental conditions should be eliminated as far as possible.
- (iv) The machining of parts should be accurate.
- (v) The measurement of physical dimensions, on which the accuracy of the standard depends predominantly, should be done with most sophisticated techniques available.
- (iv) The rigidity of the construction should be insured.

In the recent past, the techniques of establishing primary standards have been drastically refined so that accuracy attainable has become of a very high level.

4'23'3. Secondary Standards

The secondary standards are the basic reference standards used in industrial measurement laboratories. The responsibility of maintenance and calibration of these standards lies with the particular industry involved. These standards are checked locally against reference standards available in the area. Secondary standards are normally sent periodically to the national standards laboratories for calibration and comparison against primary standards. The secondary standards are sent back to the industry by the national laboratories with a certification as regards their measured values in terms of primary standards.

4'23'4. Working Standards

The working standards are the major tools of a measurement laboratory. These standards are used to check and calibrate general laboratory instruments for their accuracy and performance. For example, a manufacturer of precision resistances, may use a Standard Resistance (which may be a working standard) in the quality control department for checking the values of resistors that are being manufactured. This way, he verifies that his measurement set up performs within the limits of accuracy that are specified.

4'24. Standards for Mass and Length

Primary Standard of Mass. We have stated before that the material representation of unit of mass is the Prototype kilogramme preserved at the International Bureau of Weights and Measures at Severs near Paris. The primary unit of mass is a Prototype kilogramme kept at National Physical Laboratories of every country. This has an accuracy of 1 part in 10^8 and is occasionally verified against the standard kept at the International Bureau.

Secondary Standards of Mass. The secondary standards of mass are kept by industrial laboratories. The standards have an accuracy of 1 ppm and are checked against the primary standard.

Working Standards of Mass. The working standards of mass are available i a wide rangen

of values so that they suit any kind of application. The accuracy of working standards are of the order of 5 ppm. The standards are verified against the secondary standard.

International Units of Length. The international unit of length, the metre, was originally defined as the ten millionth part of the meridional quadrant through Paris. The unit was materially represented by the distance between two lines engraved on a platinum-iridium bar preserved at the International Bureau of Weights and Measures. However, in 1960, the metre was redefined more accurately in terms of an optical standard. This was the orange-red radiation of krypton atom. The internationally recognised krypton-86 discharge lamp when excited and observed under well defined conditions, emits orange light whose wavelength constitutes the basic unit of length. This can be measured to an accuracy of 1 ppm. The metre is equal to 1,650,763.73 wavelengths in vacuum of the orange-red light radiation of the krypton-86 atom.

Working Standards of Length. There is a wide range of working standards of length in industry. These are usually precision Gauge Blocks made up of steel. These blocks have two parallel surfaces and the distance between the two surfaces is specified. The accuracy tolerance of this distance is usually 0.5–0.25 micron. It should be noted that 1 microne = 10^{-6} m high. The most outstanding advantages gained by using of gauge blocks is their precision, low cost and accuracy. These features of gauge blocks have made it possible to manufacture interchangeable industrial components in very economical manner.

4.25. Atomic Frequency and Time Standards

The recent advancements and refinements of atomic resonators have made control of frequency of an oscillator to a great extent. Therefore it is now very easy to construct atomic clocks of great precision and accuracy by frequency conversion (since frequency is inversely proportional to time). The transmission between two energy levels E_1 and E_2 of an atom is accompanied by the emission (or absorption) by radiation given by :

$$E_2 - E_1 = h\nu \quad \dots(4.4)$$

where h = Planck's constant,

and ν = a physical constant (which is a frequency) provided that the energy states are not affected by external conditions such as magnetic fields. This physical constant depends only on the internal structure of the atom.

Since frequency is the inverse of time interval, atomic clocks can be constructed on the above mentioned principle. Investigations were done on atomic transitions of various metals. The International Committee of Weights and Measures defines the second in terms of the Cesium transitions, assigning a value of 9,192,631,770 Hz to hyperfine transition of cesium atom unperturbed by external fields.

The advantages of atomic standards are :

(i) The accuracy of atomic standards is much higher than that of standards based upon astronomical measurements.

(ii) Determination of time intervals can now be made in a very short time (a few minutes at the most) and with much better accuracy than is possible with astronomical measurements that many a times took many years to complete. Some of the atomic clocks are in operation which give a precision of 1 μ s per day. They form the primary frequency standard.

(iii) The results with atomic standards are more uniform. Also they form a better and convenient time base.

4.26. Temperature Standards

Thermodynamic temperature is one of the basic SI quantities whose unit is kelvin. The thermodynamic kelvin scale is recognized as the basic scale to which all temperatures should be referred. The temperatures on this scale are designated as $^{\circ}$ K and denoted by the symbol T . The magnitude of kelvin has been fixed by defining the thermodynamic temperature of the triple

point of water at exactly 273.16°K. The triple point of water is temperature of equilibrium between ice, liquid water, and its vapour.

Since temperature measurements on the thermodynamic scale are inherently difficult, the Seventh General Conference of Weights and Measures adopted in 1927, a practical scale which has been modified several times and is now called the "International Practical Scale of Temperatures". The temperatures on this scale are designated as °C (degree Celcius) and denoted by the symbol t . The Celcius scale has two fundamental points the boiling point of water as 100°C and the triple point of water as 0.01°C, both points are established at atmospheric pressure. A number of primary fixed points have been established above and below the two fundamental points. These are the boiling point of oxygen (−182.97°C), the boiling point of sulphur (444.6°C), the freezing point of silver (960.8°C) and the freezing point of gold (1063°C).

The numerical values of all these points are reproducible quantities at atmospheric pressure. The conversion between kelvin scale and the Celcius scale is :

$$t(^{\circ}\text{C}) = T(\text{K}) - T_0$$

where

$$T_0 = 273.16 \text{ degrees.}$$

The primary "Standard Thermometer" is the platinum resistance thermometer of special construction.

4.27. Luminous Intensity Standards

The primary standard of luminous intensity in a full radiator (black body or Planckian radiator) at the temperature of solidification of platinum (2,042 K approximately). The "candela" is then defined as one sixtieth of luminous intensity per square centimetre of one full radiator.

Secondary standards of luminous intensity are special tungsten lamps calibrated against basic standards. The primary and secondary standards of luminous intensity are described in chapter 19.

4.28. Electrical Standards

In order to assign values to electrical standards, it is necessary to determine only two standards in terms of defining units. From electrical measurements it is then possible to assign values to the remaining standards.

Therefore national laboratories usually maintain standards of emf and resistance and base the values of other standards on these two.

All electrical measurements are based upon three fundamental quantities : current, resistance and voltage. A system of measurements depends upon definitions of units of these quantities. These three electrical units are not independent but are related by Ohm's law : $E=IR$. Thus, the definition of any two units in terms of other related physical quantities is sufficient to determine the definition of the third. Accordingly, if any two units are available as samples of calibration, the instruments which measure the third unit may also be calibrated.

The unit of current can be established in terms of the physical dimensions of a current balance which measures the force exerted between two current carrying coils.

The unit of resistance can also be established in an absolute manner through the indirect process of establishing an absolute standard for inductance. When an a.c. voltage is applied to the inductance standard, a reactance is obtained in ohm and this can be compared in magnitude to a resistance which will serve as a standard. The ohm can be determined by a capacitance standard. Also the ohm can be determined directly by Lorenz method.

An absolute unit of emf could also be established, but experimental difficulties make it much less accurate than the units for current and resistance and hence there would be disagreement among the results when compared with results obtained by Ohm's law. This is the foremost reason that the unit of emf is not defined by an independent experiment but is calculated from the units of current and resistance by Ohm's law.

In practice, an absolute volt can be obtained by passing an absolute ampere through an absolute ohm. This is possible because both absolute ampere and an absolute ohm are physically realizable.

However, there are some practical difficulties. For example: once standards of current, resistance and emf are established by definition it is necessary that samples of unit current, resistance and emf are constantly available for comparison with other samples and other associated instruments. It is possible, though not easy, to construct a standard ohm which is accurate and permanent. But it is highly impractical to maintain a standard current for the routine calibration of ammeters and voltmeters. This is because each absolute determination of current takes a long time involving precision work. Working with a current balance is a protracted and time consuming job, which would make instrument calibration very costly and also inconsistent.

Hence we conclude that from the view-point of practical considerations, the absolute determination of emf using a current balance and an absolute ohm, is not feasible. Therefore an alternative becomes imperative. Logically, the alternative should be an independent source of emf.

Fortunately for the science of measurement, it was discovered that certain types of chemical batteries developed and maintained emf of great constancy, so that they could serve as practical reference of emfs. Therefore, the practical standard of electrical measurement is the ohm, which is a direct absolute standard, and the volt, which is originally determined from the absolute measurement of current. No working standards of current are maintained. Only working standards of resistance and emf are maintained.

4.29. Emf Standards

The primary, secondary and working standards of emf are described below:

4.29.1. Primary Standard of Emf

The primary voltage standard is the saturated normal Weston cell which was developed by Edward Weston in 1892. This is a voltaic cell.

Construction and Characteristics. The construction of a saturated normal Weston cell is shown in Fig. 4.3. The positive electrode is mercury and the negative electrode is an amalgam of cadmium which is 1 part of cadmium and 7 parts of mercury. The electrolyte is a saturated solution of cadmium sulphate. A paste of mercurous sulphate Hg_2SO_4 is placed on top of mercury. This acts as the depolarizing agent. An excess of solid crystals of $CdSO_4 \cdot 8H_2O$ (cadmium sulphate) in the electrolyte space and the depolarizer assures that the solution will be saturated at all temperatures. A simplified representation of the cell reaction is:

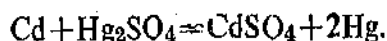

As long as the amalgam has both a solid and liquid phase present, the emf of the cell remains absolutely constant.

The Weston standard cell is contained in an H-shaped glass vessel. The limbs of the H vessel are hermetically sealed and the connections to the external circuit are made through platinum wires. Sulphuric acid is added to act as electrolyte. Saturated cells are normally allowed to age for a year before they are considered to be of constant emf. Following this period, their life span appears indefinite excluding the possibility of accidents.

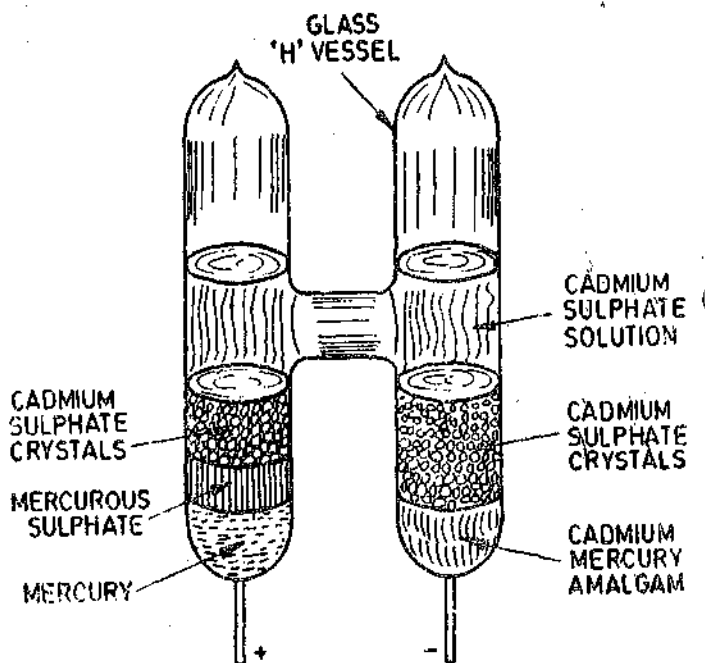

Fig. 4.3. Saturated Weston cell.

The emf of the cell is 1.01864 volt. The emf of the cell changes with temperature and the equation relating emf to temperature is :

$$E_t = E_{20} - 0.000046(t - 20) - 0.00000095(t - 20)^2 + 0.00000001(t - 20)^3$$

where E_t = emf of cell at any temperature $t^\circ\text{C}$,

and E_{20} = emf of cell at 20°C .

The cell voltage drops by about $40 \mu\text{V}/^\circ\text{C}$. The cell is kept in an oil bath to control its temperature within 0.01°C .

The cell has a long life if handled carefully. It has a life span of about 10 to 20 years. The drift in value of voltage is about $1 \mu\text{V}$ per year.

The saturated cell is a standard for maintenance of the volt and as such it is only used in standardizing laboratories. Saturated cells are not used for ordinary work because of temperature requirements and also because they are not portable. The unsaturated cell is used for ordinary measurements.

Precautions :

1. Mercurous sulphate is sensitive to light and therefore it should not be exposed to light. Exposure to incandescent light at ordinary levels of illumination is much less serious than direct sun light or even light from the usual fluorescent lamps.

2. It has been mentioned above that the cell has a temperature co-efficient of about $-40 \mu\text{V}/^\circ\text{C}$. In that it has an effect $+310 \mu\text{V}/^\circ\text{C}$ at the positive terminal and $-350 \mu\text{V}/^\circ\text{C}$ at the negative terminal. Therefore it is important to keep the entire cell at a uniform temperature to secure as much cancellation of positive and negative effects. Hence these cells are always used in close temperature regulation, usually an oil bath held constant to better than 0.01°C .

3. Saturated cells should be kept in an upright position because if they are tilted there is always the danger of mixing of electrode materials. Therefore these cells cannot be shipped and are sent through special messengers.

4. The principal limitation of the use of standard cells is the current drawn from the cell at any time. This should be negligibly small. Even this small current should be allowed to flow for a very short period of time. It should be understood that standard cells are potential devices and will be damaged if current is drawn from them.

It is very difficult to specify the maximum value of current that can be drawn from a standard cell since the damage to the cell is a function of both magnitude of the current and the duration of its flow. The makers specify the maximum value as $100 \mu\text{A}$ but this should be regarded as an extreme figure. This means that the current drawn from the cell should be less than $100 \mu\text{A}$ and this current should flow momentarily.

A voltmeter should never be used for measuring the voltage of a standard cell. Firstly because of the current drain, there is a possibility of damage to the cell and secondly this measurement is meaningless since the cells have a high internal resistance (about 600 to 800 Ω). The voltage should be measured with the help of a potentiometer.

A cell should be handled with care and never be short circuited. The excessive current causes a change in emf which may be permanent because the cell may not be able to recover. A cell once short circuited, should be regarded with suspicion and hence is of little value as a standard.

When using the cell in potentiometric work, a resistance of 20,000 Ω should be inserted in series with the cell in order to avoid excessive drain of current when there is unbalance.

It is important that leakage resistance between the terminals of the cell be very high otherwise it may not give the standard voltage it is supposed to give. This is illustrated by the following example.

Example 4.12. A standard cell has a voltage rating of 1.018500 V and an internal resistance of 500 Ω . The insulation resistance between its terminals is 5 M Ω . Find the current drain due to insulation resistance. Calculate also the difference between the internal voltage and the terminal voltage.

Solution : Current flowing through the insulation resistance = $\frac{1.018500}{500 + 5 \times 10^6} = 0.204 \times 10^{-6} \text{ A}$
 $= 0.204 \mu\text{A}$.

Thus there is a constant drain of a current of 0.204 μA .

Voltage drop = $0.204 \times 10^{-6} \times 500$
 $= 0.102 \times 10^{-3} \text{ V} = 0.102 \text{ mV}$

\therefore Difference between internal voltage and terminal voltage = 0.102 mV

Terminal voltage = $1.018500 - 0.000102$
 $= 1.018398 \text{ V}$.

4.29.2. Secondary Standard of Emf

The secondary standard of Emf is the unsaturated Weston cell.

Unsaturated Weston cell Construction and Characteristics. The construction of an unsaturated cell is shown in Fig. 4.4. The unsaturated cell is similar to a saturated cell except that it does not have the cadmium sulphate crystals (CdSO_4). It has the same electrodes but the solution is saturated at 4°C, and, therefore, unsaturated at room temperature. In addition, a 'sputum' or retaining member (porous plugs in this case) is used over each electrode to hold the material in place and hence these cells are considered portable. After being moved from one place to another, the cell should be allowed a few days to settle so that the results obtained from measurements involving cells are accurate.

The cells are enclosed in bakelite case which is lined with 1.5 mm thick copper to help keep all parts of the cell at a uniform temperature.

Many characteristics of unsaturated cell are different from those of a saturated cell. Not all unsaturated cells have the same emf. In fact the emf saturated cells differ from one to another. The emf of new unsaturated cells lies between 1.0190 to 1.0194 absolute volt. Therefore each cell must be calibrated against the primary standard in order to know its exact emf. The temperature at which this emf is measured should also be specified.

The unsaturated cell becomes less stable with age ; yet it is remarkably good. The decrease in emf is about 30 to 50 μV per year. It is recommended that the cells be checked by returning them to a standardizing laboratory once a year for certification.

An unsaturated cell has a shorter life than a saturated type, yet experience has shown that some cells last even 20 years. In addition to age, the life of a cell depends on the kind of treatment the cell has received.

The temperature coefficient of the unsaturated cell is less than of a saturated cell. It is $-10 \mu\text{V}/^\circ\text{C}$. Thus it can be used for most purposes without temperature correction, if the temperature of use does not differ by a few degrees from the calibration temperature. This cell, also has a positive temperature effect at one electrode and negative at the other. Therefore it is important to keep all parts of the cell at the same temperature.

Precautions. Same precautions as for use of saturated cells should be followed while using unsaturated cells. The only difference is that the unsaturated cells are portable and can be shipped.

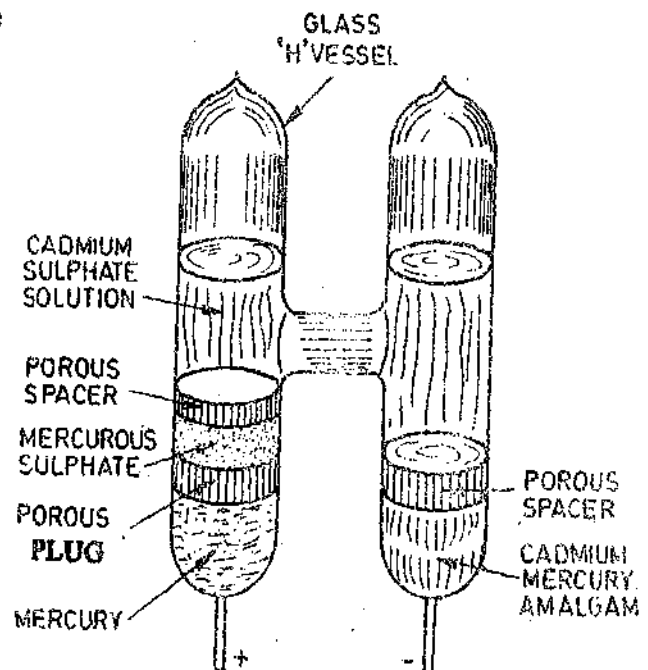

Fig. 4.4. Unsaturated Weston cell.

Besides the precautions given above cells should not be operated at temperatures below 4°C and above 40°C . Experiments made with cells beyond these limits show that the extreme upper limit of reliability occurs at 50°C . Below 4°C the emf drops rapidly and eventually the electrolyte freezes. Above 40°C the cell materials start to melt and voltage drops sharply around 55°C . It has been mentioned earlier that unsaturated cells lose emf, at an average rate of $30\text{--}50\ \mu\text{V}$ per year at normal temperature of use and storage. At higher temperatures the decrease is much more rapid and is about $240\ \mu\text{V}$ per year at 60°C .

It is recommended that the normal operating temperature be 25°C for precision work. The cells should be mounted so that they are not exposed to extremes of temperature, to drafts, steam pipes, resistors carrying current and to light.

4'29.3. Laboratory Standards of Emf

In the past standard cells were used exclusively as laboratory standards but in recent years, semi-conductor devices such as Zener controlled reference sources have replaced standard cells in practically all industrial applications.

Silicon diodes have voltage current characteristics such that an extremely sharp reverse current occurs at a point on the voltage curve known as "Zener voltage". The point indicates a breakdown of the diode under reverse voltage application, but the process is reversible if safe current and heating limits are not exceeded. The Zener voltage may be controlled over a wide range by the processing techniques used during the manufacture of the Zener diodes.

The circuit of Fig. 4'5 shows the Zener diode in a typical application as a laboratory standard. The supply voltage E is usually much higher than the Zener voltage of diode assuring breakdown of the diode. Resistor R usually has a high value and is placed in series with the diode and the battery. It serves to limit the current through the diode during breakdown to a safe value. In addition when the supply voltage varies for any reason, most of this variation is taken up in the voltage drop across R with a very small change in diode current and as a result the reference voltage (output voltage) remains practically the same.

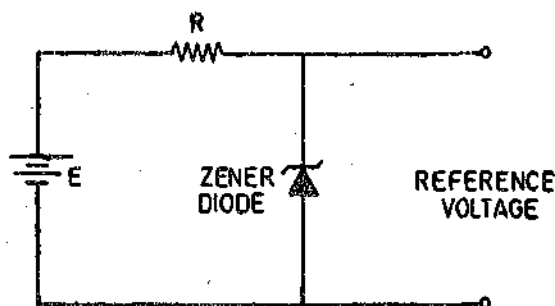

Fig. 4'5. Zener diode laboratory standard

Commercial voltage standards using Zener diodes essentially consist of :

(i) A Zener controlled voltage source placed in a temperature controlled environment to improve its long term stability.

(ii) A precision output voltage divider. The temperature is controlled to $\pm 0.03^{\circ}\text{C}$ over an ambient temperature range of 0°C to 50°C providing an output stability of the order of 10 ppm/month. The four available outputs are :

- (a) a $0\text{--}1000\ \mu\text{V}$ source with $1\ \mu\text{V}$ precision,
- (b) a $1.000\ \text{V}$ reference for potentiometer measurements with ratio box,
- (c) a $1.018+(\Delta)$ reference for saturated Weston cells comparisons,
- and (d) a $1.019+(\Delta)$ reference for unsaturated Weston cell comparison.

4'29'4. Higher Voltage Zener Sources and Temperature Effects

It is many a times convenient from the practical point of view to build higher voltage standard sources. In the following passages problems associated with higher voltage sources and effect of temperature changes are discussed.

Zener diodes having reverse voltages in the range $4\text{--}5\ \text{V}$ are used because they have negligible resistance temperature co-efficient. In many applications, standard sources of much higher voltage

han 5 V are desired. Under these circumstances there is a distinct advantage of using several low voltage diodes series, rather than one high voltage diode. This is because low voltage diodes of the order of 5 V give a negligible temperature co-efficient while use of a single high voltage diode may give rise to a high temperature co-efficient.

There is another advantage of using low voltage diodes. The resistance in the Zener region changes on the basis of the voltage for which they are produced. A 5 V diode has a resistance of about 5Ω while a diode of 40 V range has a resistance of 1000Ω . Thus, it is clear that it is preferable to use eight 5 V diodes (connected in series) rather than using a single 40 V diode in order to have a good value of voltage regulation. Thus several low voltage diodes connected in series give much better results than one high voltage diode.

It has been experienced that Zener diodes indicate permanence of value to a satisfactory level. However, it is not expected that they will replace the standard chemical cells in work involving high precision or in standardizing laboratories. However, they may serve to maintain a calibrated voltage applied to potentiometer circuit for thermocouple work and recording potentiometers.

Their major advantages are :

(i) Commercial voltage-reference using Zener diodes plus additional circuitry to improve regulation and stability are available with voltage outputs in the vicinity of $1.0191 \text{ V} \pm 0.01$ percent which allow them to be substituted for a standard cell.

(ii) The advantage of these standards over standard cell is that, unlike the standard cell, the semi-conductor device is immune to the effects of short circuit and overload conditions.

(iii) An attractive proposition is substitution of standard chemical cells by Zener sources in recording potentiometers which may be subjected to freezing temperatures. This is on account of the fact that the standard cells cannot work below 4°C while Zener sources give good accuracies at all temperature if properly compensated.

(iv) Chemical cells can be built to voltage level of about 1 volt while Zener sources can be built to any voltage level. Thus Zener sources are preferable where higher voltage standard sources are required.

(v) Spring board or other applications where vibration is constantly present do not present ideal conditions for chemical cells. The Zener sources which are rugged may furnish the accuracy required under such conditions.

(vi) The constant voltage drop of a Zener diode may be utilized in voltage regulators, compensators, limiters, clippers or scissors, voltage reference units and voltage standards.

4.30. Primary Standards of Resistance

The absolute measurement of the ohm is carried out by the International Bureau of Weights and Measures in Severs and also by the national laboratories, which preserve a group of Primary Resistance Standards. Fig. 4.6 shows a primary resistor of 1Ω value. The standard resistor is a coil of wire made up of manganin. This material is chosen for wires of standard resistor as it has a high resistivity and has a negligible resistance temperature co-efficient.

The resistance coil is mounted in a double walled metal container. This is done in order to prevent any change in the resistance value due to moisture conditions of the atmosphere.

The Resistance Standards are explained in greater details on pages 102-109.

4.31. Current Standards. It is obvious that it is impossible to build a current standard in the same sense that a standard of resistance is built up. Current can be defined either in terms of an electrochemical equivalent of silver or in terms of force exerted in a current balance like the Rayleigh's current balance. Such standards are

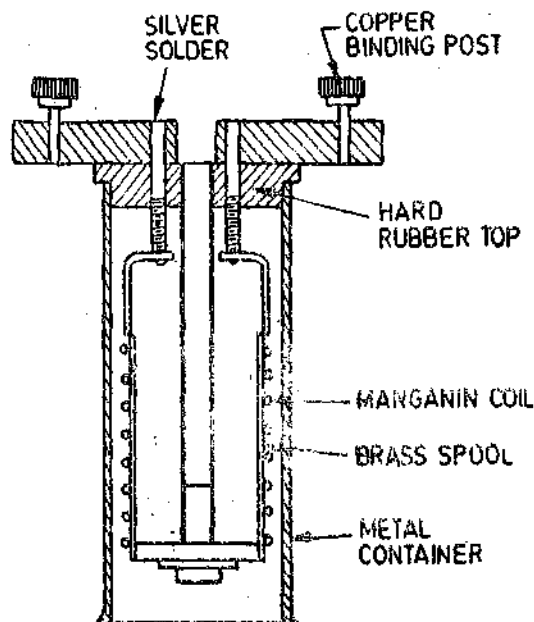

Fig. 4.6. Primary Resistance Standard.

rarely used in modern practice as we can easily and accurately measure the value of current with the help of potentiometer. This potentiometer is calibrated against a standard cell. The value of the current is known by measuring the voltage drop across a standard primary resistance.

The metric system of units (SI) defines the "ampere" (the fundamental units of current) as the constant current which, if maintained in two straight parallel conductors of infinite length and negligible cross-section placed 1 m apart in vacuum, will produce between these conductors a force equal to 2×10^{-7} newton per metre length. Earlier measurements were with a current balance as explained above. They were rather crude and need was felt to produce a more practical and reproducible standard for national laboratories.

4'32. Inductance Standards. Standards of mutual and self-inductance are described in Chapter 5. on page 110-115.

4'33. Capacitance Standards. Capacitance standards are described on page 115-122.

UNSOLVED PROBLEMS

1. (a) State Coulomb's inverse square law for electric charges and magnetic poles
(b) Derive the dimensional equation for current in the e.m. system.
(c) Derive dimensional equation for electric potential in both e.s. and e.m. systems.
(d) Deduce the value of permeability of free space in R.M.K.S. system compared to its value in C.G.S. system.

2. Derive the dimensions of the following quantities in L, M, T, I system.

- | | | |
|--------------------------|--------------------------|-------------------|
| (i) Potential difference | (ii) inductance | (iii) capacitance |
| (iv) magnetic flux | (v) flux density | (vi) m.m.f. |
| (vii) reluctance | (viii) magnetizing force | (ix) Resistance |
| (x) current. | | |

3. Show that the product $\frac{1}{\sqrt{\mu k}}$ has the dimensions of velocity.

4. Use dimensional equations to obtain suitable units for (i) μ_0 and (ii) ϵ_0 .

5. Use dimensional equations to find out whether the following expression is dimensionally correct or not.

$$R_4 = \frac{R_1(1 + \omega^2 R_2^2 C_3^2)}{\omega^2 R_1 R_2 C_3}$$

where R_1, R_2, R_3 are resistances, C_3 , a capacitance,

and $\omega = 2\pi f$, f being a frequency.

$$\left[\text{Ans. Incorrect, correct equation } R_4 = \frac{R_1(1 + \omega^2 R_2^2 C_3^2)}{\omega^2 R_1 R_2 C_3^2} \right]$$

6. In the course of a calculation, the following expression was obtained.

$$I = \frac{V\omega M}{[(\omega M + R_1)^2 + \omega^2 L_1 R_1^2]^{1/2}}$$

Check whether the equation is dimensionally correct. If not suggest any corrections.

$$\left[\text{Ans. Incorrect ; } I = \frac{V\omega M}{[(\omega^2 M^2 + R_1 R_2)^2 + \omega^2 L_1 R_1^2]^{1/2}} \right]$$

7. The voltage V across the coil of a telephone receiver when a current I is flowing through it may be written as

$$V = I \left(Z + \frac{A^2}{z} \right)$$

where

$$Z = R + j\omega L$$

$$A = 2B_0 \frac{N}{R}$$

$$z = r + j \left(\omega m + \frac{s}{\omega} \right)$$

R = the resistance.

- L = the inductance, and
- N = number of turns of the receiver coil ;
- B_0 = the flux density in air gap ;
- R = the reluctance of the magnetic circuit ;

and r , m , and s are respectively the equivalent mechanical resistance, mass and stiffness of the receiver diaphragm. Suggest a suitable unit of each of the quantities involved. Find the dimensions of each quantity, and so make a check of the equation.

8. Prove that the following equation is dimensionally correct :

$$e = Blv$$

where

e = e.m.f. generated in a conductor,

B = flux density,

l = length of conductor,

and

v = peripheral velocity of conductor.

9. Prove that the following equations are dimensionally correct.

$$(i) \quad r = \frac{R\omega^2 M_1 M_2}{R^2 + \omega^2 L^2} \quad (ii) \quad C = \frac{1}{\omega^2 M}$$

where

r, R = resistances,

M_1, M_2, M = mutual inductances,

L = self inductance,

C = capacitance

ω = angular frequency.

10. The pull of an electromagnet is given by the expression :

$$P \propto B^a A^b \mu_0^c$$

where

B = flux density in the air gap of the magnet

A = area of magnet

μ_0 = permeability of air gap.

Determine the values of a , b and c from the dimensions of the quantities involved. [Ans. $a=2, b=1, c=1$]

Circuit Components (Resistors, Inductors and Capacitors) and their Residues

5.1. Residues. It is almost impossible to manufacture a component so that it has only one property. For example, a resistor has an associated inductance and capacitance, a capacitor has leakage resistance and an inductor has resistance and interturn capacitance. The impurities present in a component produce unwanted quantities which are called Residues. However, a particular quantity like resistance in a resistor, capacitance in a capacitor, inductance in an inductor may be made to dominate and so that the effect of residues is very small and it is possible to design pure components for specified limits of accuracy.

5.2. Resistors

Resistors and resistive networks are extensively used in instrumentation systems and for measurement work.

The foremost properties of materials used for preparing resistances for precision measurement work are :

1. Stability or permanence with time. It is required to avoid the change in value of resistance with time.
2. Robust construction.
3. Small temperature co-efficient. It is required in order that the variation in resistance values owing to change in temperature is small.
4. Low thermo-electric e.m.f. with copper. The thermo-electric emf with copper is particularly important in bridge networks and potentiometers, as large measuring errors may occur even if the thermo-electric emf is a few μV .
5. High resistivity. It is required in order that the size of the resistors is small.
6. Resistance to oxidation, corrosion and moisture.
7. Ease in manufacture.
8. Cheapness.

5.3. Resistance Materials. No single material possesses all the above mentioned properties and, therefore, only that material is selected which is best suited for the particular case.

The most widely used materials for precision resistors are :

Manganin. It is an alloy of copper, manganese and nickel and is universally used as resistance material for precision resistors and for resistance measuring apparatus. It has a nominal composition of 84 per cent copper, 12 percent manganese and 4 per cent nickel.

This material has a resistivity of 0.45 to $0.50 \times 10^{-6} \Omega\text{m}$ (nearly 25 times that of copper) and develops a thermo-electric force against copper of 2 to 3 $\mu\text{V}/^\circ\text{C}$. When properly heat treated, it gives a stable resistance value with time.

The foremost property of manganin is that it has almost a zero temperature coefficient of resistance near about room temperatures. A representative value may be taken as 0.004 per cent per °C at 20°C. Manganin is used for resistances of very high accuracy when the temperature rise is not expected to rise above 15 to 20°C.

Constantan. These are a series of alloys of nickel and copper containing 40 to 60 per cent nickel, with a small amount of manganese to improve their mechanical properties. All these alloys exhibit similar electrical properties. They are sold as constantan, or under various trade names for use as thermocouple materials. They have thermoelectric powers against copper of about 40 μV per °C. However, except for their large thermoelectric powers, the electrical properties of these alloys are remarkably similar to those of manganin.

Constantan has a resistivity at ordinary temperatures of about 25 times that of copper (about the same as manganin), is corrosion resistant, inexpensive, and easy to work. This can be easily soft soldered to copper.

It finds extensive use in cases where its high thermoelectric power against copper is not a disadvantage. For example it is frequently used in resistors designed for a.c. operation. It also finds application in resistors of 1000 Ω and above as in voltmeter multipliers where the thermal emf generated at copper constantan junction is negligibly small as compared to the emf being measured.

Nickel Chromium Alloys. These alloys have a somewhat higher temperature co-efficient of resistance than that of manganin and constantan. Nichrome is an example of this class of alloys. These alloys cannot be used in precision resistances.

Nichrome has a very high resistivity (about 50 times that of copper) and resists corrosion even at very high temperatures. It is often used in rougher class of resistors, where small size is all important or where the operating temperatures are high.

However, these alloys are difficult to solder.

Gold Chromium. It is an alloy of recent introduction, which appears to be very promising for some applications. It is made with slightly over 2 percent of chromium. This alloy has a resistivity at room temperature of about 20 times that of copper. Its temperature co-efficient can be made extremely small by baking it at fairly low temperatures. It has a thermo-electric power of 7 or 8 μV per °C with copper. For many applications, the extremely small temperature co-efficient of gold chromium alloys make their use desirable. They are used for making heat resistant standard resistors.

Although its resistance temperature co-efficient is small near room temperature the range over which the co-efficient is small is 20°C to 30°C.

5.4. Spools (Formers) for Coils

D.C. Resistors. In early days, wooden spools were used for resistance coils. However, owing to demand for increased accuracy and high quality, the use of wooden spools has been abandoned and in their place metal spools are used for d.c. resistors. The change from wooden spools to metal was made for the following reasons :

(i) Wooden spools absorb moisture and consequently expand or contract. This results in varying stresses being applied to the wire with attendant changes in resistance.

(ii) Metal spools readily dissipate heat produced in the coil due to passage of current. This is because the coil is intimately in thermal contact with the metal spool and, therefore, the heat produced in the coil is easily transferred to the spool. Thus with metal spools both inner and outer surfaces of the coil are effective in dissipating heat while with wooden formers only the exposed outer surface of the coil dissipates heat.

Metal spools are ordinarily of brass, which has a coefficient of thermal expansion nearly the same as that of the resistance alloys. This avoids large changes in stress in the coil because of temperature changes.

A.C. Resistors. For many a.c. applications the use of metal spools is undesirable even out of

question. For such applications when wire wound coils are required, ceramic coil formers are used almost universally. The disadvantages of ceramic spools for resistors of high precision, are their poor heat conductivity and the fact that their temperature co-efficients of linear expansion are very much smaller than for the resistance wire.

5.5. Resistance Wires. The resistance wire is generally double silk or silk and cotton covered, and usually the wire is enamelled before these coatings are applied.

High quality resistors are wound with only one layer of wire although this requires use of smaller wire than the multilayer coils as they give several advantages :

(i) Heat dissipation is more satisfactory with single layer coils. On the other hand temperature rise of central layers is quite high with multilayer coils.

(ii) Single layer coils are more stable. Multilayer coils are more subject to change in resistance because of changes in atmospheric humidity and are less stable in resistance with time.

5.6. Ageing. After being wound, the coils are artificially aged by baking in air at about 150°C for 48 hours. Some manufacturers impregnate coils with shellac varnish before baking while others impregnate them with special waxes after baking. Ageing makes the coil resistance stable with time.

5.7. Annealing. Mechanical fatigue during winding, thermal overloading and ageing of the insulating materials may adversely affect the properties later. The effect of annealing a coil of wire is to reduce internal stresses, thus making the resistivity more uniform. Baking at 150°C improves the stability with time, it would be logical to expect greater stability if the heating were carried on at a sufficiently high temperature to obtain actual annealing. In the case of manganin, annealing takes place between $500-600^{\circ}\text{C}$.

5.8 Resistance Standards. The comparison of resistances is considerably easier than their absolute measurement and, therefore, it is convenient to have standard resistors.

5.9. Resistance Standards for D.C. The construction of this type of standard is shown in Fig. 5.1. The resistor consists of a coil of platinum-silver or manganin wire non-inductively wound on metal former (bobbin). The wire is shown in Fig. 5.2. The winding is known as a coil of bifilar winding.

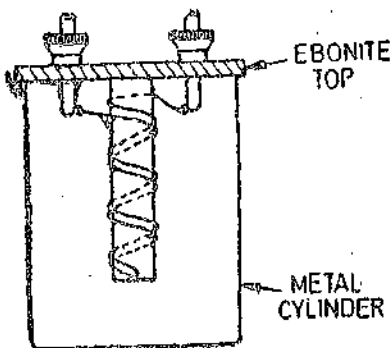

Fig. 5.1. Resistance standards for D.C.

The coil is fixed in an outer metallic case with an ebonite top which carries the terminals. The space between coil and the outer case is filled with paraffin wax. The terminals consist of long copper rods hard soldered to the ends of the coil.

5.10. Low Resistance Standards. Low resistance standards of value less than $1.0\ \Omega$ normally have to carry large currents. These resistance standards are frequently used for potentiometer measurements where-in it is convenient to have a one volt drop.

Therefore, the low resistance standards must be designed to dissipate considerable quantities of heat. The heat dissipating surface should be large so that the temperature rise is kept low. This is done in order that the resistance value does not vary with different current values.

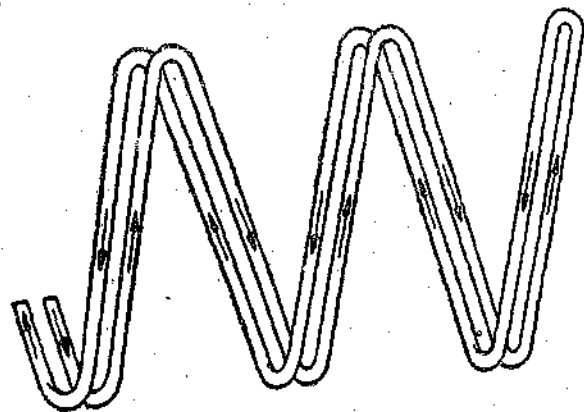

Fig. 5.2. Bifilar Winding.

If the current carried by the resistance is small, the standard is air-cooled and the resistance is in the form of thin and wide strips giving a large area for heat dissipation. When the current carried by the resistance is large, it is immersed in oil and enclosed in a metal container. The oil may be stirred by a propeller driven by an external motor, or in the cases of very heavy currents, the coil is cooled by circulating cold water. In all cases, provision is made for the measurement of temperature.

All low resistance standards are of four terminal type. They are provided with two current and two potential terminals. Fig. 5.3 shows a simple form of a four terminal resistance. It consists of a strip, or strips of manganin hard soldered into copper end pieces which are soft soldered into massive copper blocks. The current connections are made to these blocks. These current terminals are away from the resistance strip. Potential terminals are nearer to the strip. The current density is not uniform in the region of point of connection to the external circuit and if the resistor is to give a fixed potential difference for a given current the potential difference must be measured between points nearer to the resistance strip where the current density is uniform. Thus in a four terminal resistor the current terminals are located away from the resistance strip and the potential terminals are kept nearer (with such an arrangement the contact resistance of leads at the current terminals is of no importance as the current is determined by the remainder of the circuit. The contact resistance at potential terminals is also immaterial as the voltage measuring source would not draw any current from this circuit).

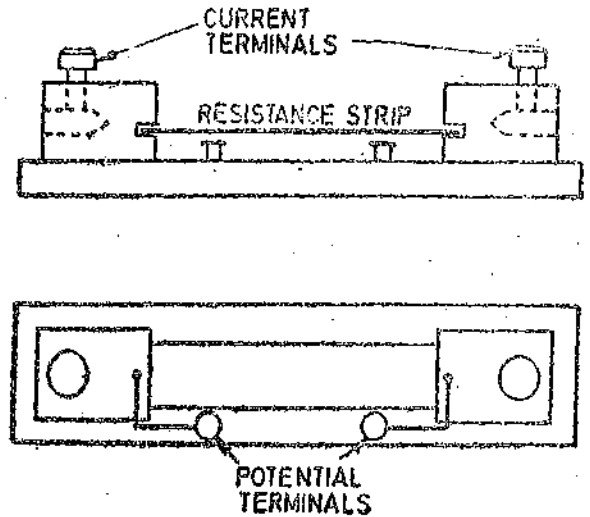
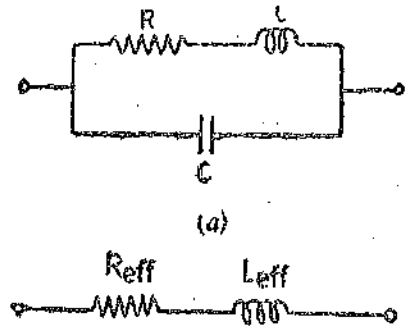

Fig. 5.3. Four terminal resistor.

5.11. Standard Resistances for A.C. Circuits. In a.c. measurements it is absolutely necessary that the standard resistors should be non-reactive, i.e., they should not have any inductance and capacitance. In fact, it would be ideal if a resistor could be constructed that it only behaves as a pure resistance at all frequencies. All resistors including the precision ones have, however, inductive and capacitive effects.

5.12. Frequency Errors of Resistors. A resistor may be represented to a first approximation by the circuit of Fig. 5.4 (a) which shows inductance in series with the resistance and this combination shunted by a capacitance. This representation is valid for low and medium frequencies.



- R = resistance of coil measured with d.c. ; Ω ,
- L = inductance of coil ; H,
- C = capacitance of coil ; F,
- ω = angular frequency ; rad/s.

Let Z be the equivalent impedance of circuit of Fig. 5.4 (a).

Therefore, the equivalent (or effective) impedance $Z = \frac{(1/j\omega C) (R + j\omega L)}{R + j\omega L + (1/j\omega C)}$... (5.1)

$$= \frac{R + j\omega(L - \omega^2 L^2 C - CR^2)}{1 + \omega^2 C^2 R^2 - 2\omega^2 LC + \omega^4 L^2 C^2}$$
 ... (5.2)

Now for a resistor that has been constructed so that its inductance and capacitance are small, we have :

$$\omega^2 LC \ll 1$$

and the term $\omega^4 C^2 L^2$ may be neglected because it is the square of a small number.

$$\therefore \text{Eqn. 5.2 may be written as } Z = \frac{R + j\omega [L(1 - \omega^2 LC) - CR^2]}{1 + \omega^2 C(CR^2 - 2L)} \quad \dots(5.3)$$

Writing the real and imaginary terms separately,

$$\text{effective resistance } R_{eff} = \frac{R}{1 + \omega^2 C(CR^2 - 2L)} \quad \dots(5.4)$$

$$\text{and effective reactance } X_{eff} = \frac{\omega [L(1 - \omega^2 LC) - CR^2]}{1 + \omega^2 C(CR^2 - 2L)} \quad \dots(5.5)$$

Now X_{eff} will be small and hence term $\omega^2 LC$ may be dropped from the numerator of Eqn. 5.5. giving.

$$X_{eff} = \frac{\omega(L - CR^2)}{1 + \omega^2 C(CR^2 - 2L)} \quad \dots(5.6)$$

$$\text{The effective inductance is } L_{eff} = \frac{L - CR^2}{1 + \omega^2 C(CR^2 - 2L)} \quad \dots(5.7)$$

The effective inductance is also called **Residual Inductance**.

Phase Angle. The effect of inductance in resistors may be expressed by their "Phase Defect Angle", ϕ , by which the current lags the voltage.

$$\tan \phi = \frac{X_{eff}}{R_{eff}} = \frac{\omega(L - CR^2)}{R} = \omega \left(\frac{L}{R} - CR \right) \quad \dots(5.8)$$

Time Constant. The characteristics of a resistor are sometimes expressed in terms of time constant.

$$\text{Time constant } \tau = \frac{\text{effective inductance}}{\text{effective resistance}} = \frac{L - CR^2}{R} = \frac{L}{R} - CR \quad \dots(5.9)$$

The time constant of a resistance box may be either positive or negative depending on which of the terms, L/R or CR predominates. The low valued resistance (1 or 10 Ω) generally have a positive time constant, which means they display a net inductive effect. The capacitance usually predominates for higher values (1000 Ω) giving a negative time constant. A 100 Ω resistance is likely to have zero time constant.

The time constant of a resistor is a useful guide to its high frequency performance and values normally range between 0.5 μ s to 1 ns.

$$\text{It is apparent from eqn. 5.4 that if } CR^2 = 2L \quad \dots(5.10)$$

$$\text{We get } R_{eff} = R$$

or the effective value of resistance, R_{eff} , is equal to R the d.c. value of resistance.

$$\text{Also from Eqn. 5.6, it is clear that } CR^2 = L \quad \dots(5.11)$$

in order that the resistor has zero effective inductance and zero phase angle. The two conditions, i.e., $CR^2 = 2L$ and $CR^2 = L$ cannot be met simultaneously. It is however advisable to have zero effective inductance for which the condition is $CR^2 = L$. For such a resistor there will be small error in resistance value. The effective resistance, for zero inductance is :

$$R_{eff} = \frac{R}{1 - \omega^2 LC} \quad \dots(5.12)$$

(This is found by substituting $CR^2 = L$ in Eqn. 5.5)

Now for zero effective inductance and zero phase angle for a wide range of frequencies

$$CR^2 = L \quad \text{or } R^2 = L/C \quad \dots(5.13)$$

This means that for small resistances inductance, L , should be small while capacitance C should be large. On the other hand large resistances should be designed with a small value of C .

5.13. Methods of Reducing Residual Inductance

1. **Bifilar Windings.** The most common form of winding non-inductive resistors is the bifilar winding which has been described earlier (Fig. 5.2). The bifilar type of construction is successful in reducing the inductance to a low value. However, it has the undesirable feature of a large capacitive effect if the loop is long. Thus this construction cannot be used for high resistances and is normally used for 0.1Ω and 1Ω resistances.

If a simple bifilar winding is used the coil capacitance may become prohibitively large in high resistances. Bifilar windings may be divided into a number of loops with all the loops connected in series (Fig. 5.5). If there are n loops, the capacitance of each loop is $1/n$ of the capacitance of value of the whole length of wire if wound in a single loop. Now the capacitances of these loops are in series and, therefore, the value of total capacitance is reduced to $1/n^2$ of the value if only one loop were used.

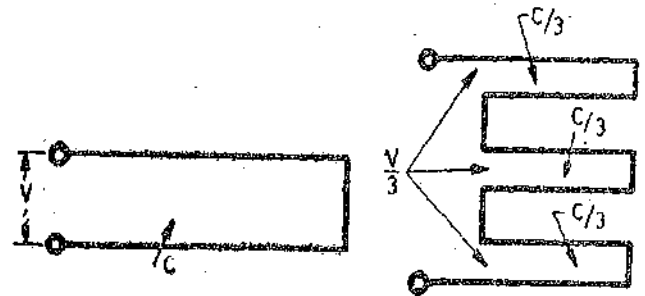

Fig. 5.5. Sectionalizing of Bifilar windings.

For low values of resistance, in which the cross-section of the conductors must be large, bifilar strips are used with the conductors separated by thin sheets of mica. In this way the residual loop formed by the conductor encloses much less area than would be the case if round wire were used. This results in reduction of inductance.

2. **Card Wound Resistors.** An alternative to bifilar winding for high resistances is a single layer winding put on a thin card made of mica or other insulating material. Inductance is fairly low due to presence of currents in the opposite directions separated by the thickness of the card. Capacitive effects are small since the starting and finishing ends of the winding are at opposite ends of the card.

3. **Ayrton Perry Winding.** For medium resistances, the most popular method is to use Ayrton Perry winding as shown in Fig. 5.6. This arrangement employs two windings connected in parallel and wound in opposite direction around a card with one winding spaced between turns of the other. This gives a better cancellation of magnetic field than single winding. There is capacitance between adjacent turns, but if there are several turns in each half of the winding the capacitances act in series and hence their total is small. This winding is more expensive to construct, and requires either more wire, or else finer wire, because of the two paths in parallel.



Fig. 5.6. Ayrton Perry Winding.

This form of winding gives extremely low time constant and is very useful for high frequency work.

Ayrton Perry windings are most popular for medium resistances. Such windings are used for ohms, tens of ohms and hundreds of ohms. They are not adaptable to high resistance units.

Some other types of construction are :

4. **Chaperon Winding.** This is a modification of bifilar winding. In this arrangement a coil is wound in an even number of layers with the winding direction reversed at the end of each layer. Fig. 5.7 shows the Chaperon method of winding. This winding is really an extension of the Bifilar principle the current in adjacent wires neutralizing one another as regards resultant magnetic field. Both inductance and capacitance are small.

5. **Curtis and Grover Winding.** It is wound on a slotted ceramic cylinder (or a slotted flat card) as shown in Fig. 5.8. Adjacent wires carry currents in the opposite direction hence magnetic

effects are small giving a small inductance. Capacitive effects are also small as the voltage between adjacent wires is only the IR drop which is small.

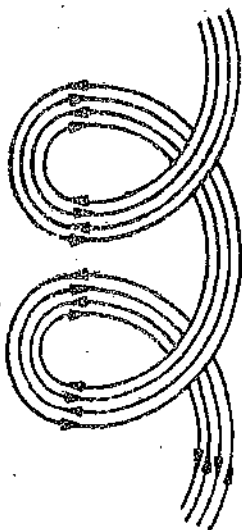

Fig. 5'7. Chaperon winding.

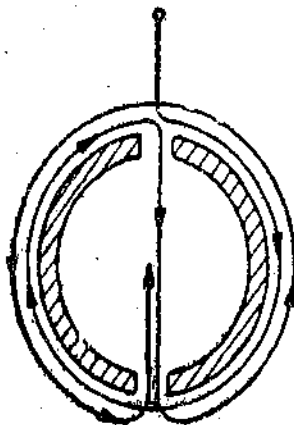

Fig. 5'8. Curits and Grover winding.

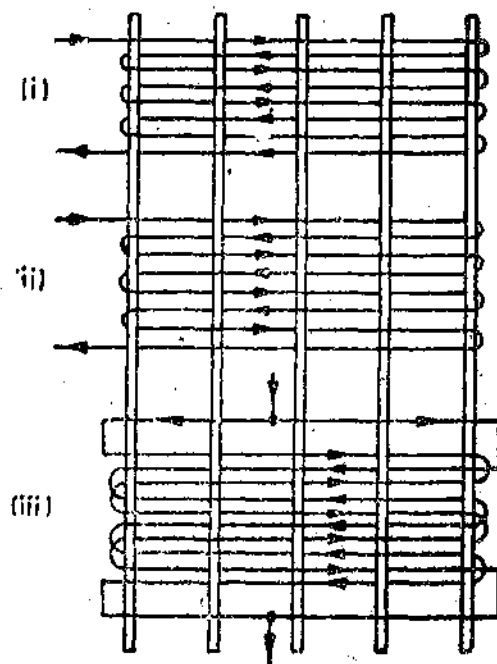

Fig. 5'9. Woven wire resistors.

6. **Woven Wire Resistance.** Woven wire resistors have been constructed in which resistance wire is woven together with silk or cotton to produce a cloth in which the wire zig-zags as shown in Fig. 5'9.

Part (i) of this diagram shows ordinary weaving. Part (ii) shows improved form of weaving where the adjacent pairs of wires lie close together.

Part (iii) shows two wires in parallel similar to Ayrton Perry winding. The inductance is very small with this arrangement.

Time constants of resistors using this construction are as low as $0.4 \mu s$ for a 100Ω resistor.

5'14. **Resistance Boxes.** An assembly of resistors which can cover a wide range of values is known as a resistance box. Each resistor is constructed according to the principles described above. These resistors are mounted in the box and are so arranged that the values of resistance can be varied in steps (usually in steps of 1Ω). The resistance is varied with the help of rotary selector switches or with the help of key plugs. In general a rotary switch is much more convenient to use. There may be more than one selector switch in a box. It is normal to arrange for one switch to select 1 to 10Ω in steps of 1Ω , a second switch to select 10 to 100Ω in steps of 10Ω , a third switch to select 100 to 1000Ω in steps of 100Ω , and so on. Therefore, such resistance boxes are commonly known as decade resistance boxes.

A decade resistance box having two dials is shown in Fig. 5'10.

5'15. **Thin Film Resistors.** These resistors are made by depositing thin film of a metal on a cylindrical insulating support. It is possible to produce resistors of high value on account of thin film. Wire wound resistors suffer from the disadvantage of having inductance effects which are not present in thin film resistors. Thus thin film resistors can be used for high frequency work.

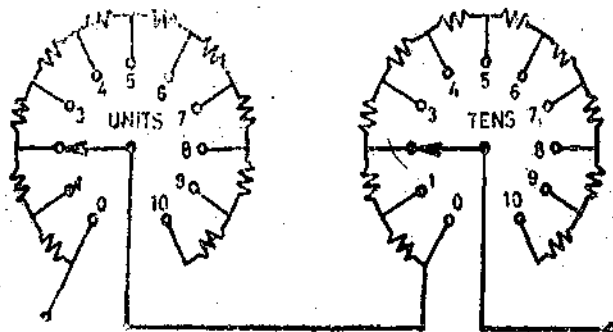
Fig. 5'10. Decade resistance box. (Set at 22Ω)

Thin film resistors are commonly made up of non metallic materials like carbon. The granules of finely divided carbon are deposited on a non-conductive base.

5'16. Composition Resistors. Carbon itself has a high resistivity and also its points between its granules have a high resistance. In fact it is possible to achieve a high value of resistance without having a carbon film but instead the carbon granules are hot moulded with a thermosetting plastic binder. Such resistors are known as composition resistors. The resistance element is a simple rod of pressed carbon granules.

Both the film and composition resistors are provided with insulation and wire leads to facilitate their connection into the circuits.

5'17. Shielded Resistors. Although high resistance coils which have very small time constants can be wound, the effective phasor angles of such units will depend upon their surroundings also. This is because the magnetic field is neutralized by adopting the arrangements described earlier but an electric field exists between different parts of the resistor when it is carrying current. Also there is an electric field between the resistor and the earth. this results in distributed capacitance between one resistor and another in a decade box. Fig. 5'11 shows how resistor is represented with various associated capacitances.

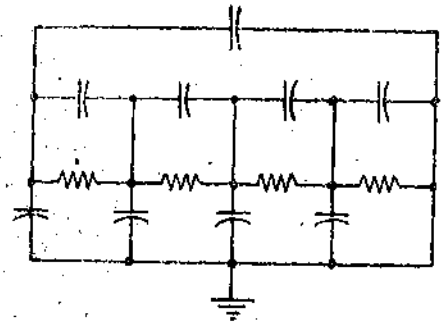

Fig.5.11. Distributed capacitance.

These distributed capacitances effect the operation of the resistor. They cause serious errors especially at high frequencies. This is because these distributed capacitance will vary the current from point to point along the resistor, and the potential drop along a particular section will not necessarily be exactly proportional to the resistance of the section. In order to make the effect of these distributed capacitances definite the resistor (or resistor sections) may be enclosed within metal shields which are maintained at fixed potentials with respect to resistors which they enclose.

In audio frequency working except for very high resistances, the primary need for the shield is to intercept external fields and it is not necessary to screen individual resistors of a decade.

Example 5'1. How much series inductance is required to render a 1000Ω resistance coil with a shunt capacitance of 10 pF practically non-reactive over a reasonable range of frequency? What is the value of effective resistance under the above conditions? The frequency is 200 kHz .

Solution. In order to make the coil non-reactive,

$$\begin{aligned} \text{Inductance } L &= CR^2 && (\text{see Eqn. 5'11}) \\ &= 10 \times 10^{-12} \times (1000)^2 = 10 \times 10^{-6} \text{ H} = 10 \mu\text{H}. \end{aligned}$$

The value of effective resistance when $L=CR^2$ is

$$\begin{aligned} R_{\text{eff}} &= \frac{R}{1 - \omega^2 LC} && (\text{See Eqn. 5'12}) \\ &= \frac{1000}{1 - (2\pi \times 200 \times 10^3)^2 \times 10 \times 10^{-6} \times 10 \times 10^{-12}} = 1000.16 \Omega \end{aligned}$$

Example 5'2. A 2000Ω resistor has a series inductance of $6 \mu\text{H}$ and a shunt capacitance of 25 pF .

- Find the effective resistance and reactance at a frequency of 100 kHz .
- Find also the phase angle and the time constant of the resistor.

Solution. Now, $R=2000 \Omega$, $L=6 \times 10^{-6} \text{ H}$,
 $C=25 \times 10^{-12} \text{ F}$ and $\omega=2\pi \times 10^5 \text{ rad/s}$

(a) Using Eqn. 5.4, effective resistance

$$R_{eff} = \frac{R}{1 + \omega^2 C (CR^2 - 2L)} = \frac{2000}{1 + (2\pi \times 10^5)^2 \times 25 \times 10^{-12} (25 \times 10^{-12} \times 2000^2 - 2 \times 6 \times 10^{-6})}$$

$$= 1998.26 \Omega$$

Effective reactance $X_{eff} = \frac{\omega(L - CR^2)}{1 + \omega^2 C (CR^2 - 2L)}$ (see Eqn. 5.6)

$$= \frac{2\pi \times 10^5 (6 \times 10^{-6} - 25 \times 10^{-12} \times 2000^2)}{1 + (2\pi \times 10^5)^2 \times 25 \times 10^{-12} (25 \times 10^{-12} \times 2000^2 - 2 \times 6 \times 10^{-6})}$$

$$= -59 \Omega.$$

(b) Phase angle $\phi = \tan^{-1} \frac{X_{eff}}{R_{eff}} = \tan^{-1} \frac{-59}{1998.26} = -1.7^\circ$

Time constant $\tau = \frac{L}{R} - CR$ (see Eqn. 5.9)

$$= \frac{6 \times 10^{-6}}{2000} - 25 \times 10^{-12} \times 2000 = 47 \times 10^{-9} \text{ s} = 47 \text{ ns.}$$

Example 5.3. A 10Ω resistor has a time constant of $+30 \text{ ns}$.

(a) Find the phase angle of the resistor at a frequency of 1 kHz .

(b) Calculate the value of the capacitor to be connected in parallel with the resistor to make its phase angle equal to zero.

Solution. Time constant $\tau = \frac{L}{R} - CR$

$$\tan \phi = \omega \left(\frac{L}{R} - CR \right) = \omega \tau = 2\pi \times 1000 \times 30 \times 10^{-9} = 0.188 \times 10^{-3}$$

\therefore Phase angle $\phi = \tan^{-1} (0.188 \times 10^{-3}) = 38.9''$

Suppose C_1 is the external capacitance connected in parallel to make the phase angle zero.

$$\therefore \frac{L}{R} - (C_1 + C)R = 0 \quad \text{or} \quad \frac{L}{R} - CR - C_1R = 0$$

or $\tau - C_1R = 0$

Hence $C_1 = \frac{\tau}{R} = \frac{30 \times 10^{-9}}{100} = 0.3 \times 10^{-9} \text{ F} = 300 \text{ pF}$

INDUCTORS

5.18. Standards of Inductance. We have observed that the dimensions of inductance are $[ML]$ in the e.m. system. Thus the dimensions of inductance are that of length only if μ is taken as dimensionless. Hence the values of standards of both self and mutual inductance depend upon their physical dimensions together with the number of turns in the coil.

While designing and constructing Inductance Standards, the following considerations should be taken into account :

(i) The design and construction should be such that a rigidly standard accurate formula exists relating the value of inductance with the physical dimensions.

(ii) The design should be such that accurate measurement of physical dimensions is possible. The materials used should be easily workable mechanically.

(iii) The materials used should be such that the value of inductance remains constant irrespective of the environmental and circuit conditions. This requires that :

(a) The materials used should be such that their dimensions do not change with time, temperature and humidity.

(b) The inductance should be independent of the value of the current passing. This requires that no ferromagnetic materials be used. When we use ferromagnetic materials, the value of permeability and hence inductance is dependent upon flux density which in turn depends upon the current flowing in the coil. Hence the inductance of an inductor constructed with ferromagnetic cores depends upon the value of the current passing. In order that inductance be independent of the current passing, air cored coils should be used for standards of inductance.

(iv) The resistance of the windings should be very low as compared with their inductance or the inductor should have a high L/R ratio. The ratio of inductive reactance to resistance of a coil is known as its Storage Factor or Q Factor. The Q factor is defined as :

$$Q = \frac{\omega L}{R} \quad \dots(5.14)$$

(v) The effective inductance and resistance should be affected to a minimum by frequency. This requires that :

(a) There should be minimum losses. Ferromagnetic materials should never be used as eddy current losses in them are appreciable. The use of inductors having ferromagnetic cores is completely ruled out for high frequency applications.

(b) The coils should use stranded wires as otherwise the eddy current losses in conductors become large especially at high frequencies.

(c) The use of metallic parts should be avoided as the eddy currents induced in them affect the value of inductance.

(vi) The inductor should be so designed that capacitive effects are negligible. This is particularly important for inductors working at high frequencies where the interturn capacitance may drastically change the effective value of inductance.

(vii) The inductor should be desirably unaffected by external magnetic fields and should produce a minimum interfering field of its own.

5.19. Formers for Inductance Coils. Marble is used for making formers or bobbins for the coils. The reasons for selecting marble are :

- (i) It does not warp and is unaffected by atmospheric conditions.
- (ii) It has a high electrical resistance and, therefore, it acts as a perfect insulator.
- (iii) It is a non-magnetic material.
- (iv) It has a very large small co-efficient of thermal expansion.
- (v) It can be easily machined.
- (vi) It is comparatively cheap and is easy to work.

5.20. Coils of Inductance Coils. The shape of the coils should be such that a high value of inductance to resistance ratio is obtained. The L/R ratio is maximum for a coil of simple circular shape with a square cross-section, with the mean diameter of coil equal to about 3 times its depth. High values of L/R ratio can be obtained by using greater weight of copper or by using iron core.

5.21. Standards of Mutual Inductance

1. Primary Standards. These standards are always fixed standards *i.e.*, single valued. The Campbell type of primary standard is shown in Fig. 5.12. It consists of a single layer, primary coil of bare copper wire wound under tension in grooves machined in a cylinder of marble. The primary coil is divided into two parts. The two parts are connected in series and are separated from each other by a distance equal to three times the axial length of each. The secondary coil has many layers and is placed in a channel cut in the marble cylinder. The secondary coil has a diameter of about one and half times the diameter of the primary coil and

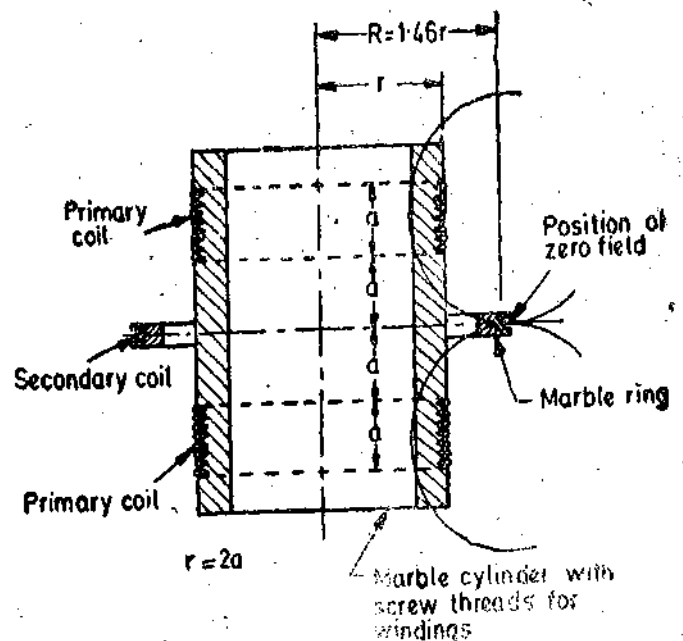

Fig. 5.12. Campbell primary standard of mutual inductance.

is situated midway between the two halves of primary coil. This arrangement is used in order that the secondary winding lies in a position of almost zero field. Thus the value of flux linked by secondary winding does not depend upon determination of its diameter to a great accuracy. This is desirable as it is difficult to assess the effective diameter of secondary winding because it has many layers. It is essential to use a multilayer secondary winding in place of a single layer winding in order to have a reasonably high value of inductance.

2. **Secondary Standards and Working-standards.** These, standards may be fixed or variable. The requirements of secondary standards are that their inductance should not vary with time and temperature and should be independent of supply frequency. Their dimensions need not be very accurately determined.

Fixed secondary standards usually consist of two coils wound on a marble or hard paraffined wood former. The coils are separated by a flange. The wire is of stranded copper in order to reduce effect of eddy currents in conductors. After winding, the coils and former are immersed in hot paraffin wax.

Variable standards are frequently used in laboratories and are known as 'Inductometers'. They consist of two sets of coils, one fixed and other movable so that the mutual inductance could be varied.

5.22. Standards of Self-Inductance

1. **Primary Standards.** The mutual inductance standards are generally regarded as primary standards of inductance as their value can be known with greater accuracy. Also the formula necessary for the calculation of the exact value of inductance for primary standards of self-inductance is very much complicated as compared with corresponding formula for mutual inductance. Hence normally primary standards of self inductance are rarely prepared and the primary standard for mutual inductance is taken as the primary standard of self-inductance.

2. **Secondary Standards and Working standards.** Secondary standards of self-inductance are constructed to have a nominal value which is usually a simple fraction of 1 H. In designing and constructing these standards all the precautions taken for constructing corresponding standards of mutual inductance are followed.

Coils for use as secondary standards are wound with silk covered stranded copper wire. The formers are made of marble. After winding the coils are immersed in melted paraffin wax for some time.

5.23. **Variable Inductances.** Variable inductors are very useful in many circuits. The principle adopted for most variable self-inductors is the use of two coils, one fixed and the other movable in series, mounted so that the mutual inductance between them may be varied. If L_1 and L_2 are the self-inductances of two coils and M is the mutual inductance between them, the resulting self-inductance L is :

$$L = L_1 + L_2 \pm 2M.$$

Therefore, the inductance can be varied from

$$L = L_1 + L_2 - 2M \text{ to } L = L_1 + L_2 + 2M$$

If the self-inductances of the two coils are equal and they are closely coupled,

$$\text{i.e. } L_1 = L_2 = M.$$

In such a case the inductance can be varied from almost a small value (nearly zero) to a maximum of nearly 4 times the inductance of one coil. It is clear that all the windings are always in circuit and, therefore, the value of resistance remains the same over the complete range of variation of L .

1. **Ayrton Perry Inductometer.** Fig. 5.13 shows the construction of a Ayrton Perry inductometer. The moving coil is mounted inside the fixed coil. The moving coil is on a spindle which also

carries a pointer and a handle at the top as shown. The scale can be graduated to read values of inductance directly.

This form of inductometer can be cheaply and easily constructed for use as a variable inductance in cases where the inductance must be variable but not necessarily known.

Its disadvantages are that it produces an external magnetic field which may effect the values of other units (instruments, inductors, resistors etc.) placed near it. Also its scale does not follow a straight line law. However, the shape of the scale can be improved by properly shaping the coils.

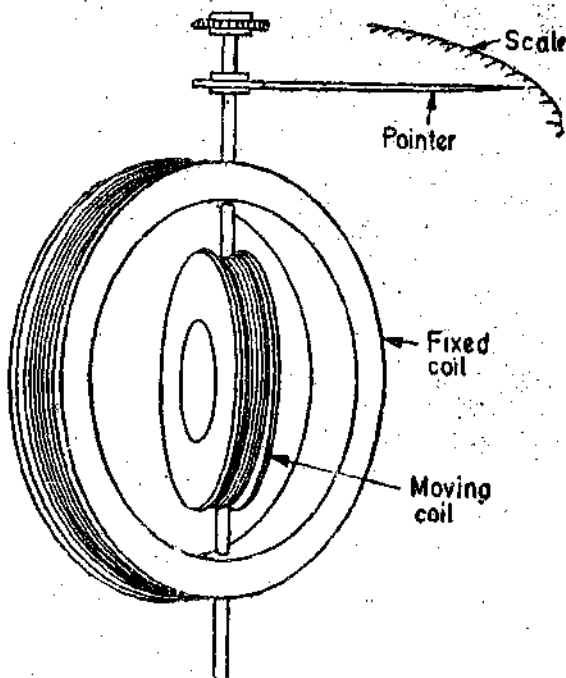
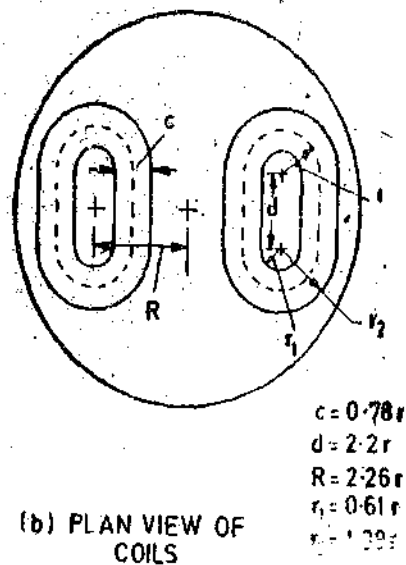
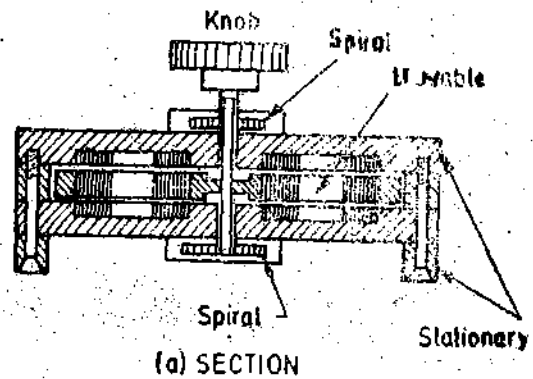

Fig. 5'13. Ayrton Perry inductometer.

Fig. 5'14. Brooks and Weaver inductometer.

2. Brooks and Weaver Inductometer. A diagram of construction of this inductometer is shown in Fig. 5'14. The middle disc has two link shaped coils set in it, and the top and bottom plates each have a coil with half the turns of the moving coil. The two groups of the coils are connected with opposite polarities, that is when the flux direction is upward in the right hand coils, it is downward on the left. One coil serves as the return flux path for the other and, therefore, the magnetic field does not spread out.

The dimensions of the coils are specially chosen to give uniform scale and also to obtain as great inductance as possible.

The Brooks inductometer is a great improvement over the Ayrton Perry type because it is compact, has high L/R ratio and does not produce any external magnetic field. Also the inductance value remains constant even if the plates warp a little.

This inductometer may be used as a variable self-inductor if the fixed and moving coils are connected in series and a mutual inductor if the coils are in different circuits.

3. Variable Mutual Inductometers A short range variable mutual inductance can be obtained by separating the connections of fixed and moving coils of the variable self-inductances described (i.e., the Ayrton Perry and the Brooks inductometers).

Long range variable mutual inductances can be constructed with a movable coil to give values upto 1000 μH say. A series of ten secondary coils of 100 μH and a decade switch will extend it to 1.1 mH and a further decade will extend to 11.1 mH. Two methods of doing this are shown in Fig. 5.15. In both the cases the position of moving coil can be adjusted to give zero inductance or given negative values. This later features being very useful in some of the applications.

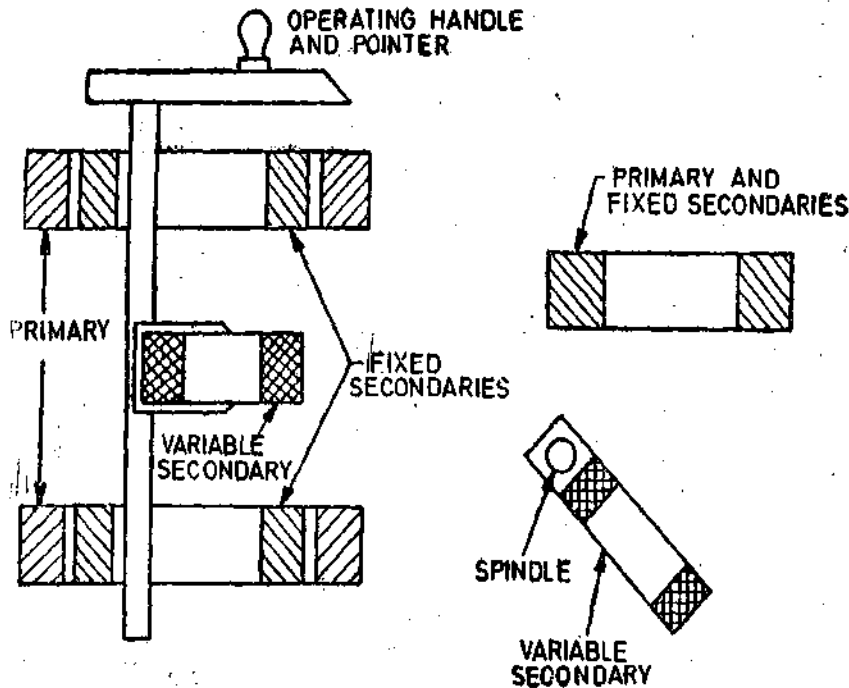

Fig. 5.15. Variable mutual inductometers.

5.24. Inductors for High Frequency Work. High frequency electronic circuits frequently employ inductances of the order of μH . These inductors are usually air cored coils consisting of a large number of turns. But in case small turns are to be used to get large inductance values, high permeability cores are used. The ferromagnetic cores for these inductors should have a low eddy current loss. Ferrite cores, made of high resistivity ferromagnetic materials are used at high frequencies as their high resistivity makes the eddy current loss smaller.

5.25. Inductors for Low Frequency Work. Large valued inductors are made by having a large number of turns wound round a core made up of a ferromagnetic material like iron. The magnetic properties of these materials are such that the magnetic flux density is increased appreciably. In this way inductances of several hundred henry are produced. The cores of iron-core inductors are laminated in order to reduce eddy current losses.

5.26. Frequency Errors in Inductors. The inductors used for measurement purposes should possess a constant value, very small losses and small leakage. The equivalent circuit of an inductor is the same as that of a resistor as shown in Fig. 5.4. The pure inductance L is in series with resistance R (an impurity), with shunt capacitance C (also an impurity). The increase of frequency causes a more proportionate increase in impedance due to the inevitable interturn capacitance. The arrangement becomes a resonating circuit with resonating frequency $f_0 = 1/(2\pi\sqrt{LC})$ Hz. At this frequency the inductor behaves as a pure resistor. At still higher frequencies the impedance becomes capacitive. Inductances for measurement purposes can therefore be used upto a frequency of $0.1 f_0$. Therefore, the equivalent circuit given in Fig. 5.4 is valid for low and medium frequencies (which are far away from the resonant frequency). At these frequencies, the expression for impedance is given by

$$Z = \frac{R + j\omega[L(1 - \omega^2 LC) - CR^2]}{1 + \omega^2 C^2 R^2 - 2\omega^2 LC + \omega^4 L^2 C^2} \quad (\text{See Eqn. 5.3})$$

In the construction of an inductor, the resistance and capacitance components are kept to a minimum. Therefore, the terms $\omega^2 C^2 R^2$ and CR^2 which involve R and C can be neglected.

$$Z = \frac{R + j\omega L(1 - \omega^2 LC)}{1 - 2\omega^2 LC + \omega^4 L^2 C^2} = \frac{R + j\omega L(1 - \omega^2 LC)}{(1 - \omega^2 LC)^2} \quad \dots(5.15)$$

The effective resistance is $R_{eff} = \frac{R}{(1 - \omega^2 LC)^2} \quad \dots(5.16)$

Using the binomial expansion $R_{eff} = R(1 + 2\omega^2 LC) \quad \dots(5.17)$

The effective reactance is $X_{eff} = \frac{\omega L(1 - \omega^2 LC)}{(1 - \omega^2 LC)^2} \quad \dots(5.18)$

Using the binomial expansion $X_{eff} = \omega L(1 + \omega^2 LC) \quad \dots(5.19)$

The effective inductance is $L_{eff} = L(1 + \omega^2 LC) \quad \dots(5.20)$

Eqns. 5.19 and 5.20 show that both the effective resistance and inductance of an inductor increase with frequency. The analysis is a simplification and can only be applied to low and medium frequencies.

Example 5.4. A coil has a resistance of 200 Ω and an inductance of 1 H when measured at very low frequency. The distributed capacitance is 200 pF. Find the percentage change in effective inductance when this coil is used at a frequency of 1000 Hz.

Also calculate the effective value of inductance.

Solution : We have $L = 1$ H and $\omega = 2\pi \times 1000 = 2000\pi$ rad/s.

From Eqn. 5.20, effective (equivalent) inductance $L_{eff} = L(1 + \omega^2 LC)$

$$\text{Percentage change} = \frac{L_{eff} - L}{L} \times 100 = \omega^2 LC \times 100$$

$$= (2000\pi)^2 \times 1 \times 200 \times 10^{-12} \times 100 = 0.79\%$$

Effective value of inductance $L_{eff} = L(1 + \omega^2 LC) = 1 \times 1.0079 = 1.0079$ H.

Example 5.5. A coil has an effective inductance 0.102 H at 1000 Hz and 0.110 H at 3000 Hz. Find the value of inductance at low frequencies and also the distributed capacitance. Find also the effective inductance at 2000 Hz.

Solution : From Eqn. 5.20, effective inductance $L_{eff} = L(1 + \omega^2 LC)$

Thus we have, $0.102 = L[1 + (2\pi \times 1000)^2 LC]$

$$0.110 = L[1 + (2\pi \times 3000)^2 LC]$$

or
$$\frac{0.110}{0.102} = \frac{1 + 36\pi^2 \times 10^6 LC}{1 + 4\pi^2 \times 10^6 LC}$$

From above we get $LC = 0.25 \times 10^{-9}$

Thus we have, $0.102 = L[1 + 4\pi^2 \times 10^6 \times 0.25 \times 10^{-9}]$

The value of inductance at low frequencies is $L = 0.101$ H

The distributed capacitance is $C = \frac{0.25 \times 10^{-9}}{0.101} = 2.475 \times 10^{-9}$ F = 2475 pF.

Effective inductance at 2000 Hz is $L_{eff} = 0.101[1 + (2\pi \times 2000)^2 \times 0.25 \times 10^{-9}]$
 $= 0.105$ H.

CAPACITORS

5.27. Loss Angle and Power Factor. A capacitor fails to present a perfect and constant

capacitance at all frequencies due to several effects. There are ohmic losses in the plates and connecting wires, interfacial polarization and power loss in dielectric etc. Therefore, a capacitor can be represented by an equivalent circuit as shown in Fig. 5'16 (a). Resistance represents the losses.

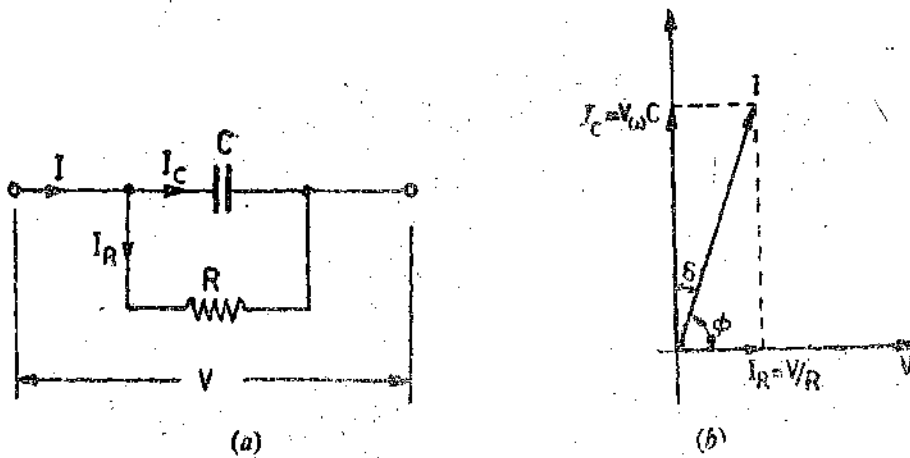

Fig. 5'16. Capacitor equivalent circuit and phasor diagram. (Parallel representation)

In the case of air and most other cases, the losses in the dielectric are very small and hence capacitors using these dielectrics may be regarded as perfect.

Fig. 5'16 (b) shows the phasor diagram of a dielectric when a voltage is impressed across it.

- V = applied voltage ; V,
- I_c = capacitive current ; A,
- I_R = active component of current ; A,
- C = capacitance (for parallel representation) ; F,
- R = resistance (for parallel representation) ; Ω
- $\omega = 2\pi f$; rad/s,
- f = frequency of supply ; Hz.

Power factor of a dielectric is the cosine of the angle between phasors representing the voltage across the dielectric and the total current through it when a sinusoidal a.c. voltage is applied across it.

Power factor $\cos \phi = \cos (90 - \delta) = \sin \delta$.

δ is called the loss angle of the capacitor. The value of δ is very small.

$\therefore \sin \delta = \tan \delta = \delta$

Dielectric loss = $VI \cos (90^\circ - \delta) = VI \sin \delta = V \frac{I_c}{\cos \delta}$. $\sin \delta = VI_c \tan \delta$.

But $I_c = \omega CV$

\therefore Dielectric loss = $\omega CV^2 \tan \delta$... (5'21)

Also $\tan \delta = \frac{I_R}{I_c} = \frac{V/R}{\omega CV}$

$= \frac{1}{\omega CR}$... (5'22)

Eqn. 5'22 is very useful for calculating dielectric loss. It is clear that the loss is determined by $\tan \delta$ and therefore this item has great importance.

The capacitor may be represented as shown in Fig. 5'17(a). The phasor diagram for this arrangement is shown in Fig. 5'17(b).

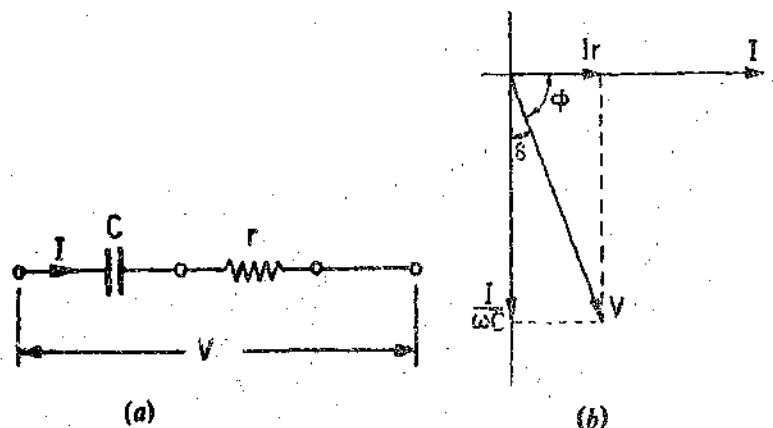

Fig. 5'17. Capacitor equivalent circuit and phasor diagram (Series representation).

C = equivalent series capacitance ; F,

r = equivalent series resistance ; Ω .

$$\text{Power loss} = VI \cos \phi = VI \sin \delta = \frac{I}{\omega C \cos \delta} I \sin \delta = \frac{I^2}{\omega C} \tan \delta \quad \dots(5.23)$$

and
$$\tan \delta = \frac{Ir}{I/\omega C} = \omega Cr \quad \dots(5.24)$$

The power factor of a capacitor is very good test of its quality. A capacitor with a small dielectric loss and small leakage will have a very low power factor, *i.e.*, a small loss angle. It is found that power factor (or $\tan \delta$) is practically constant over a wide range of frequency. $\tan \delta$ is also known as **dissipation factor** of capacitor.

$$\text{Dissipation factor } D = \frac{1}{\omega CR} = \omega Cr \quad \dots(5.25)$$

5.28. **Distributed Capacitance.** Let us consider two points A and B of a resistor as shown in Fig 5.18. (a).

When a current flows through the resistor, there is a difference of potential between A and B and therefore a capacitance must exist between these two parts as shown in Fig. 5.18 (b).

Also potential of A and B is different from that of earth and, therefore, capacitance must exist between these points and earth as shown in Fig. 5.18 (c). Thus, a resistor should be represented as shown in Fig. 5.18 (d).

Hence for any electrical equipment, capacitance must exist between turns of a layer, between layers and also between turns and earth.

These capacitances are known as distributed capacitances. The values of these capacitances are quite small. The capacitive reactance is $X_c = 1/2\pi fC$ and therefore, at low frequencies the capacitive reactance is quite high and, so, capacitive currents are very small. Hence they do not effect the current distribution. But at high frequencies, the capacitive reactance becomes smaller with the result, the capacitive currents become larger and the currents distribution is effected. This results in different values of current flowing in different sections of the resistor and thus errors are caused in measurements.

5.29. **Capacitance Standards**

1. **Primary Standards.** This dimension of capacitance in e.s. system are $[\epsilon L]$. Thus the dimensions of capacitance are those of length if the permittivity ϵ is taken as dimensionless. Therefore, values of primary standards of capacitance can be known by measuring lengths. The dimensions of such capacitors should be very accurately known in order that a primary standard is constructed. Air is usually used as the dielectric as it is the only dielectric whose permittivity is definitely known and which is free from absorption and dielectric loss.

Three types of constructions have been used for primary standards :

- (i) two concentric spheres
- (ii) two concentric cylinders
- (iii) two parallel plates with guard rings.

Parallel plate construction is normally not used, The concentric cylinder construction is

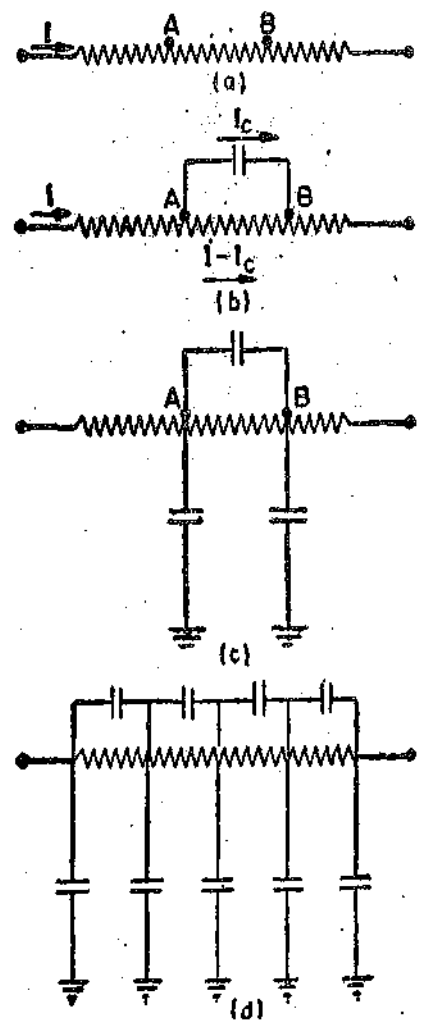

Fig. 5.18

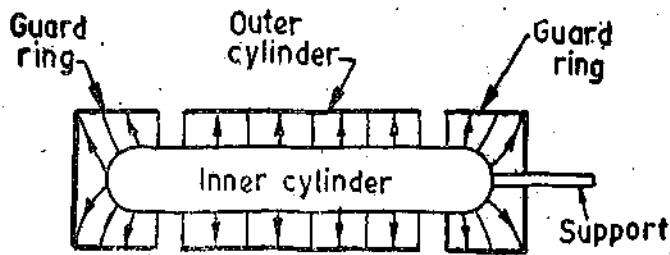

Fig. 5'19. Primary Capacitance Standard.

shown in Fig 5'19. The capacitance is calculated by assuming no fringing and hence a guard ring construction is necessary. Guard rings are maintained at the same potential as the outer cylinder but are not directly connected to it. Any fringing takes place between outer edges of guard rings and there is no fringing of electrostatic field between the outer and the inner cylinders. The supports are made of insulating materials like quartz.

The disadvantages of air as a dielectric in such capacitors are as follows :

1. Its dielectric strength is low compared with solid dielectrics. This necessitates a comparatively long gap between the plates.
2. Its dielectric constant is small as compared with solid dielectrics. This means that a capacitor using air as dielectric medium will be larger in size.
3. Dust particles settle in the gap between plates and cause leakage troubles and, therefore, precautions such as drying of air etc. have to be observed.
4. There is no solid dielectric between the plates to act as a spacer. But the plates must be rigidly fixed in position by supports of solid dielectric. Few solid dielectrics have been found to be suitable for the purpose owing to their tendency to warp and shift in position.

Air capacitors have extremely low losses, usually assumed zero, if the dielectric which supports the insulated electrodes is good insulating material and is placed in a region of low field strength. Therefore, air capacitors seem at first consideration to be well suited as primary electrical standards. It has been found difficult, however, to secure the extremely high stability needed for this purpose. Even carefully treated metal parts warp somewhat with time and so permanency is not that much as is desired in primary standards.

5'30. Vacuum and gas-filled capacitors

Vacuum and gas-filled capacitors are designed for high voltage and high frequency applications. They are not affected by variations in temperature, moisture content and humidity. They are rugged and their calibration holds good over a long range of time. They have low power dissipation and are not permanently damaged by over-voltages *i.e.*, they are self healing type. Vacuum capacitors are manufactured with capacitance values ranging from 50 pF to 500 pF. The maximum voltage level is 10 kV.

The breakdown strength of gases increases in proportion to the pressure while their dielectric constant remains unaffected. The high voltage capacitors are therefore kept in pressure vessels which are filled with nitrogen compressed to a pressure of about 16 atmosphere. These capacitors are used for voltages upto 1500 kV and have a value ranging from 20 to 200 pF. A diagrammatic section of a high voltage capacitor, fitted with guard rings, and filled with compressed gas is shown in Fig. 5'20.

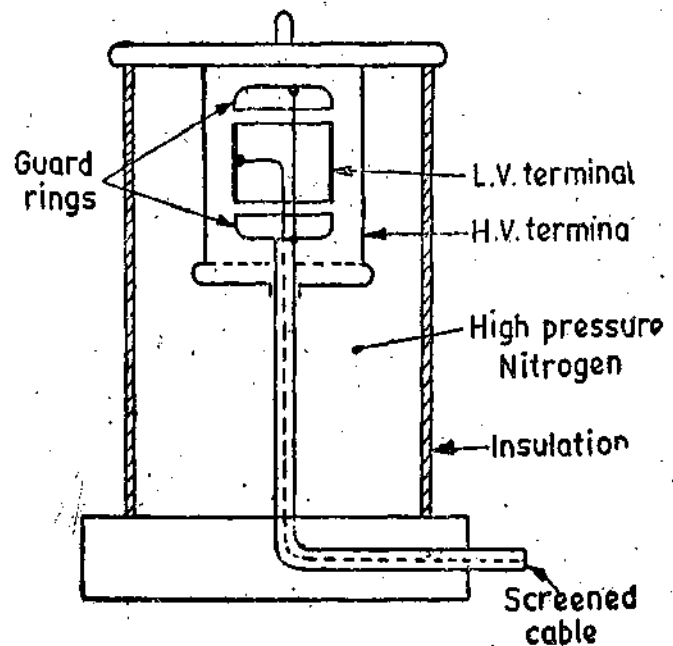

Fig 5'20. High voltage capacitor.

2. **Secondary Standards and Working for Capacitance.** Secondary standards and working standards of capacitance need not be provided with guard rings and their dimensions may

not be accurately known as their value is fixed after comparison with primary standards. However, their capacitance should not change with time and in order to achieve this we should use materials which do not warp and so alter in dimensions. The plates should be rigidly fixed in position and should not have any appreciable change in length with change in temperature. In order to give rigid support to the capacitor plates, some solid insulating material may have to be used in place of air. Such capacitors will not be free of dielectric loss. But by using materials such as fused silica, the loss can be decreased.

A number of plates may be used in place of two in order to get large capacitance without increasing the volume of capacitor. Capacitances upto $0.02 \mu\text{F}$ can be obtained.

These capacitors must be adequately screened to prevent the effect of stray magnetic fields. The screen is normally connected to one of the main terminals but occasionally it is brought out to a separate terminal and the capacitor is then known as a "three terminal" capacitor.

Mica capacitors are used where large values of capacitance are required and where dielectric loss is of no importance.

5.31. Solid Dielectric Capacitors. It is clear from Table 5.1 that by using solid dielectric materials which have a large dielectric constant than vacuum, air or compressed gases the capacitance value can be increased. In other words for the same value of capacitance, the size of the capacitors

TABLE 5.1.

Dielectric Constant of Various Materials

Material	Dielectric Constant
Argon (0°C, 1 atm)	1.000545
Hydrogen (0°C 1 atm.)	1.000264
Air (19°C, 1 atm.)	1.0006
Air (19°C, 100 atm)	1.0548
Benzene (20°C)	2.284
Methanol (20°C)	33.62
Water (0°C)	88.00
Water (100°C)	55.33
Paper	2.0
Glass	4.0-6.0
Mica	6.9-9.2
Nylon	3.5
Porcelain	6.0-8.0
Titanium Dioxide	14-110

can be reduced. Several dielectric mediums are used in making capacitors, the most common of which are impregnated paper, mica and polystyrene. Paper is not used for capacitors meant for measurement work. Mica is used as a dielectric in the best working standards of capacitance. It has a dielectric constant of about 8, its specific volume resistivity $10^{14} \Omega$, its breakdown voltage 100 kV/mm and its co-efficient of linear expansion $5 \times 10^{-6}/^\circ\text{C}$. However the performance of mica capacitors is effected by change in frequency.

Plastic film capacitors have plastic, (e.g., polystyrene) film as the dielectric medium and electrodes are metal film plates deposited directly on the dielectric. Polystyrene has a dielectric constant of 2.4 and is not affected by moisture.

Plastic materials have very high resistivity and thus have high d.c. resistance. The dielectric losses are low even at frequencies as high as 1 MHz. The temperature co-efficient is between -100 to $-200 \times 10^{-6}/^\circ\text{C}$ and their maximum operating temperature is 85°C .

Polystyrene capacitors are particularly suited for integrating and differentiating networks because of absence of dielectric after effect.

Ceramic Capacitors. These capacitors are widely used for instrumentation work as transducers. They are manufactured the same way as the polystyrene capacitors. Capacitors with different ceramic dielectrics which is usually titanium dioxide are used for a varied type of instrumentation applications. The type of capacitor to be used for a particular application depends upon the dielectric constant of the dielectric material used and the response at various frequencies.

One type, with a dielectric constant between 6 to 16, has low dielectric loss even at frequencies as high as 100 GHz. Another type, with dielectric constant of nearly 90, can be made with a wide range of temperature co-efficients which vary from $+200$ to $-800 \times 10^{-6}/^{\circ}\text{C}$.

There is another type which has a dielectric constant between 1000 to 5000. Thus this capacitor is tremendously small in size.

5.32. Variable Capacitors. Continuously variable capacitors, having air as dielectric medium, are multiple type. The shape of the plates is usually semi-circular (Fig. 5.21).

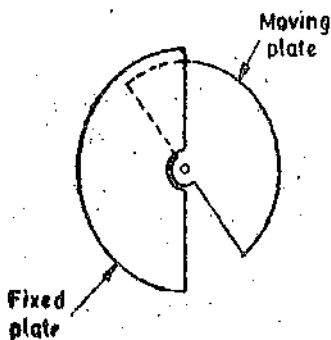

Fig. 5.21. Variable capacitor.

There are two sets of plates of fixed and the other moving. The plates are arranged so that the moving plates can be rotated in the air gap between the fixed plates. The capacitance is varied owing to variation of area of moving plate interleaving with the fixed plates.

The frame, stator rods, and rotor shafts are made of alloys of aluminium which combine the mechanical strength of brass with light weight of aluminium. The plates are also of aluminium, so that all the parts have the same temperature co-efficient of linear expansion. The capacitor is provided with a slow motion worm gear device for high accuracy in setting and reading.

The capacitor may be provided with a vernier degree scale and calibration chart or may be calibrated to read directly in pico farad.

5.33. Decade Capacitance Boxes. In practice, decade capacitance-boxes are very popular. Fig. 5.22 (a) shows a decade capacitor. There are ten fingers in the moving plate. When each group of fingers is embraced within the fixed plates there is no change in the value of capacitance for small angular movements. The capacitance angular displacement curve is shown in Fig. 5.22 (b). This diagram clearly shows how well the condition of non-variation of capacitance for small changes

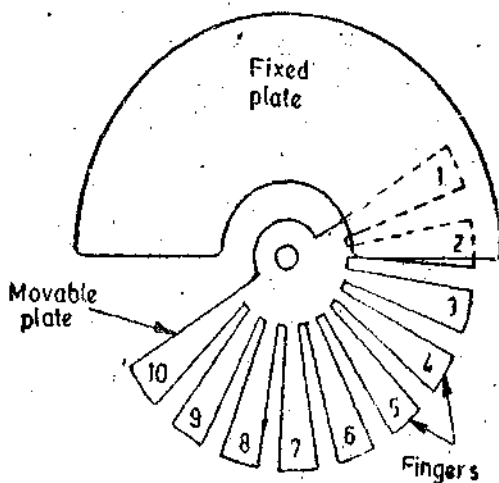

(a)

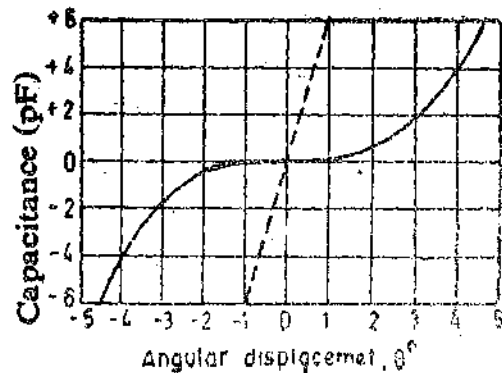

(b)

Fig. 5.22. Decade capacitance box.

in displacement is met in practice. Special compensating techniques are adopted to overcome the fringing effects. The dotted curve in Fig. 5.22 (b) is for an ordinary variable capacitor having the same capacitance range and linear capacitance law. It is clear from the curve (with firm lines) that precise angular positioning of the plates is not necessary as the ten positions, each located by a click mechanism, provide a decade of capacitance.

Air is used as a dielectric medium for the capacitor and hence this is a low loss capacitor. The capacitor has the advantage of being highly stable and the reading errors due to finely graduated scales (as in the case of continuously variable capacitors are eliminated). Thus a very high degree of precision is achieved in this capacitance box.

In modern practice decade boxes having three or four decades giving capacitance values upto $1.11 \mu\text{F}$ and $11.1 \mu\text{F}$ respectively in steps of $0.001 \mu\text{F}$ each are used.

5.34. Frequency Errors in Capacitors. A capacitor may be represented as shown in Fig. 5.23. r and L represent the resistance and inductance of leads, C is a pure capacitance shunted by a resistance R representing the dielectric loss. Thus the resistance, R , in the equivalent circuit will have a value which is a function of frequency. However, in the following analysis it is assumed that the capacitor is to be operated at low or medium frequencies such that R may be considered as having constant magnitude.

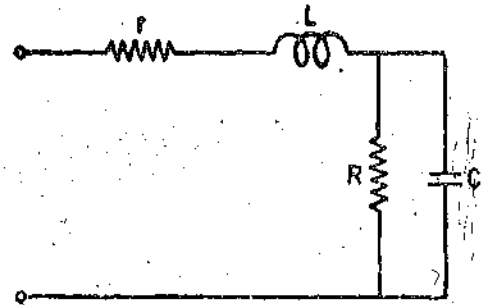

Fig. 5.23. Equivalent circuit of capacitor.

The impedance is :

$$Z = r + j\omega L + \frac{R/j\omega C}{R + 1/j\omega C} = r + \frac{R}{1 + \omega^2 R^2 C^2} + j\omega \left[L - \frac{CR^2}{1 + \omega^2 R^2 C^2} \right] \quad \dots(5.26)$$

the effective reactance is $X_{eff} = \frac{1}{j\omega C_{eff}}$ where C_{eff} = effective capacitance

$$\therefore \frac{1}{j\omega C_{eff}} = j\omega \left[L - \frac{CR^2}{1 + \omega^2 R^2 C^2} \right]$$

$$\text{or } \frac{1}{\omega C_{eff}} = -\omega L + \frac{\omega CR^2}{1 + \omega^2 R^2 C^2} \quad \text{or } \omega C_{eff} = \frac{1 + \omega^2 R^2 C^2}{\omega CR^2 - \omega L(1 + \omega^2 R^2 C^2)}$$

In a capacitor $\omega^2 C^2 R^2$ is very large as compared to 1.

$$\therefore \omega C_{eff} = \frac{\omega^2 R^2 C^2}{\omega CR^2 - \omega^3 R^2 C^2 L} = \frac{\omega C}{1 - \omega^2 LC}$$

$$\text{or } C_{eff} = \frac{C}{1 - \omega^2 LC} \quad \dots(5.27)$$

For medium frequencies, the value of effective capacitance may be written as :

$$C_{eff} \approx C(1 + \omega^2 LC) \quad \dots(5.28)$$

At a frequency $f_0 = 1/2\pi\sqrt{LC}$, a resonant condition is produced. Under this condition the reactance vanishes and the capacitor behaves like a pure resistor. It is therefore important that the inductance of leads is kept to a minimum so that resonant frequency is high. The capacitor for measuring purposes can be used only for frequencies $f < 0.1 f_0$ if an error of less than 1% is desired.

$$\text{The effective series resistance (medium frequency) is : } R_{eff} = r + \frac{R}{1 + \omega^2 R^2 C^2} \quad \dots(5.29)$$

$$\text{The loss angle is } \tan \delta = \frac{(\omega CR^2 - \omega L - \omega^3 R^2 C^2 L)}{r + \omega^2 R^2 r C + R} \approx \frac{1 - \omega^2 LC}{\omega r + 1/\omega CR} \quad \dots(5.30)$$

At low frequencies, the effects of the series inductance L , and the series resistance r are negligible.

$$\therefore \text{The effective series resistance (low frequency) is } R_{eff} = \frac{R}{1 + \omega^2 C^2 R^2} \quad \dots(5.31)$$

$$\text{and the effective capacitance is } C_{eff} = C + \frac{1}{\omega^2 CR^2} \quad \dots(5.32)$$

$$\text{The loss angle is also given by } \tan \delta = \omega Cr + \frac{1}{\omega CR} \quad \dots(5.33)$$

As the frequency applied to a capacitor is increased the values of capacitance and $\tan \delta$ show a fall in magnitude until the effects of inductance become important when an increase in loss angle and effective capacitance occurs.

Example 5.6. The leads to the plates of a 100 pF capacitor have a resistance of 0.5 Ω and an inductance of 0.3 μH . The dielectric losses at the operating frequency of MHz are equivalent to a leakage path of 50,000 Ω . Find the equivalent capacitance and the loss angle of the capacitor at this frequency.

Solution : Capacitance	$C = 100 \times 10^{-12} \text{ F.}$
Shunt resistance	$R = 50,000 \Omega.$
Resistance of leads	$r = 0.5 \Omega.$
Inductance of leads	$L = 0.3 \times 10^{-6} \text{ H. } \omega = 2\pi \times 10 \times 10^3 = 20 \times \pi \times 10^6 \text{ rad/s}$

$$\text{From Eqn. 5.27 effective capacitance } C_{eff} = \frac{C}{1 - \omega^2 LC} \quad (\text{see Eqn. 5.27})$$

$$= \frac{100 \times 10^{-12}}{1 - (20 \times \pi \times 10^6)^2 \times (0.3 \times 10^{-6})(100 \times 10^{-12})} = 113.4 \times 10^{-12} \text{ F} = 113.4 \text{ pF.}$$

$$\text{Effective resistance } R_{eff} = r + \frac{R}{1 + \omega^2 R^2 C^2} = 0.5 + \frac{50,000}{1 + (20\pi \times 10^6)^2 \times (50,000)^2 \times (100 \times 10^{-12})^2} = 1 \Omega.$$

$$\text{Loss angle } \delta = \tan^{-1} \delta = \omega R_{eff} C_{eff} = 20\pi \times 10^6 \times 1 \times 113.4 \times 10^{-12} = 0.0071 \text{ rad.} = 24.4'.$$

Loss angle calculated from Eqn. 5.33.

$$\delta = \tan^{-1} \delta = 20\pi \times 10^6 \times 100 \times 10^{-12} \times 0.5 + \frac{1}{20\pi \times 10^6 \times 100 \times 10^{-12} \times 50,000} = 0.00632 \text{ rad} = 21.7'.$$

UNSOLVED PROBLEMS

1. A coil has a resistance of 2000 Ω and a shunt capacitance of 30 pF. Calculate the value of series inductance to render the coil non-inductive over a reasonable range of frequency. [Ans. 120 μH]
2. A 1000 Ω resistor has a series inductance of 5 μH and a shunt capacitance of 20 pF. Find the effective resistance and reactance at 20,000 Hz. Calculate the phase angle and time constant of resistor at this frequency. [Ans. 999.68 Ω , -18.8 Ω , -1° 5', 1.8×10^{-8} s]
3. An inductive coil has a resistance of 400 Ω and an inductance of 3 H when measured at a very low frequency. The distributed capacitance is 100 pF. Find the percentage change in effective inductance when this coil is used at 1000 Hz. [Ans. 1.2%]
4. A coil has effective inductance of 2.1 H and 2.15 H at frequencies of 2 kHz and 4 kHz respectively. Determine the true value of inductance. Also determine the distributed capacitance. [Ans. 2.08 H, 25.45 pF]
5. The resistance and inductance of leads of a 100 pF capacitor are 10 Ω and 0.25 μH respectively. The leakage resistance is 100 k Ω . Find the value of effective capacitance, effective resistance and loss angle. The frequency is 100×10^6 rad/s. [Ans. 133.25 pF, 1.1 Ω , 0.8°]

Analog Instruments

6.1. Analog Instruments. An analog device is one in which the output or display is a continuous function of time and bears a constant relation to its input.

The analog instruments find extensive use in present day applications although digital instruments are increasing in number and applications. The areas of application which are common to both analog and digital instruments are fairly limited at present. Hence, it can safely be predicted that the analog instruments will remain in extensive use for a number of years and are not likely to be completely replaced by digital instruments for certain applications.

6.2. Classification of Analog Instruments. Broadly, the analog instruments (and for that matter digital instruments) may be classified according to the quantity they measure. For example an instrument meant for measurement of current is classified as an **Ammeter** while an instrument that measures voltage is classified as a **Voltmeter**. Thus we have wattmeters, power factor meters, frequency meters etc.

Electrical instruments may also be classified according to the kind of current that can be measured by them. Electrical instruments may be classified as instruments for:

(i) direct current (d.c.), (ii) alternating current (a.c.), and (iii) direct and alternating current (d.c./a.c.).

Instruments depend for their operation on one of the many effects produced by current and voltage and thus can be classified according to which of the effects is used for their working. The various effects used are listed in Table 6.1 on page 126.

The analog instruments are also classified as: (a) Indicating, (b) Recording, (c) Integrating.

Indicating Instruments are those instruments which indicate the magnitude of a quantity being measured. They generally make use of a dial and a pointer for this purpose. Ordinary voltmeters, ammeters and wattmeters belong to this category.

The analog indicating instruments may be divided into two groups:

(i) electromechanical instruments, (ii) electronic instruments.

Electronic instruments are constructed by addition of electronic circuits to electromagnetic indicators in order to increase the sensitivity and input impedance.

Recording Instruments give a continuous record of the quantity being measured over a specified period. The variations of the quantity being measured are recorded by a pen (attached to the moving system of the instrument; the moving system is operated by the quantity being measured) on a sheet of paper carried by a rotating drum. For example, we may have a recording voltmeter in a sub-station which keeps record of the variations of supply voltage during the day.

Integrating Instruments totalize events over a specified period of time. The summation, which they give is the product of time and an electrical quantity. Ampere hour and watt hour (energy) meters are examples of this category. The integration (summation value) is generally given by a register consisting of a set of pointers and dials.

The analog instruments may also be classified on the basis of method used for comparing the unknown quantity (measurand) with the unit of measurement. The two categories of instruments based upon this classification are:

1. Direct Measuring Instruments. These instruments convert the energy of the measurand directly into energy that actuates the instrument and the value of the unknown quantity is measured or displayed or recorded directly. The examples of this class of instruments are ammeters, voltmeters, wattmeters and energy metres.

2. Comparison Instruments. These instruments measure the unknown quantity by comparison with a standard. (Direct measuring instruments are the most commonly used in engineering practice because they are the most simple and inexpensive. Also their use makes the measurement possible in the shortest time). The examples of comparison type instruments are d.c. and a.c. bridges.

Comparison instruments are used in cases where a higher accuracy of measurement is required. Electrical instruments may also be classified according to their accuracy class. The limits of intrinsic error in the measured quantity for instruments for various classes of accuracy* are :

Accuracy class	0.2	0.5	1.0	1.5	2.5	5
Limits of error (percent)	± 0.2	± 0.5	± 1.0	± 1.5	± 2.5	± 5

6.3. Principles of Operation As mentioned earlier secondary instruments may be classified according to the principle of operation they utilize. The effects they utilize are :

(i) magnetic effect, (ii) heating effect, (iii) electrostatic effect, (iv) electromagnetic effect, and (v) hall effect.

6. Magnetic Effect. Consider a current carrying conductor of Fig. 6.1 (a), it produces a magnetic field in the anticlockwise direction.

We now have a uniform magnetic field as shown in Fig. 6.1 (b). Let the current carrying conductor be placed in this magnetic field. The resultant field is as shown in Fig. 6.1 (c). This results in distortion of magnetic field causing a force to act from left to right. The reversal of direction of the current will cause a force in the opposite direction, i.e., from right to left subject to the condition that the direction of the existing field remains the same.

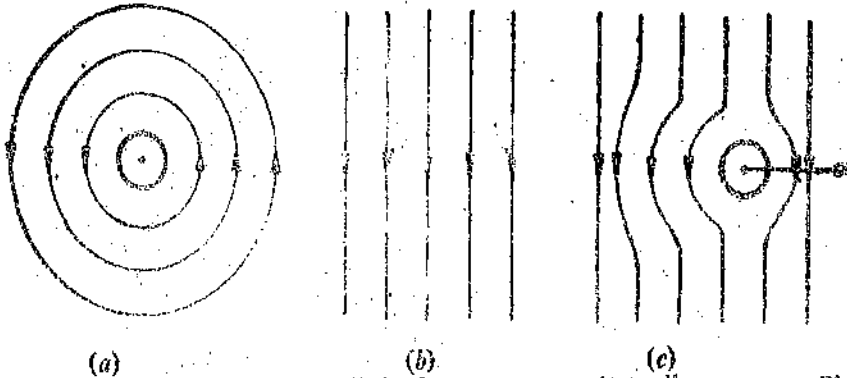

Fig. 6.1. Magnetic effect of a current carrying coil.

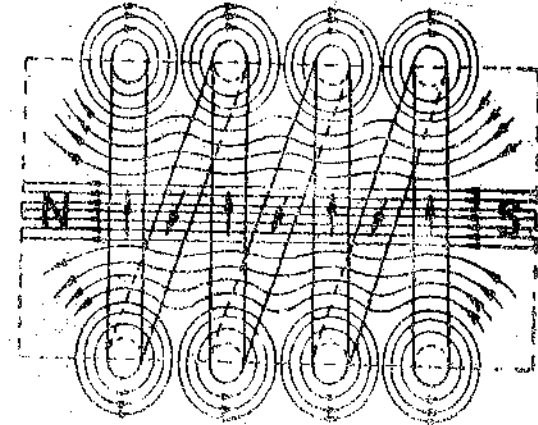

Fig. 6.2. Magnetic field produced by current carrying coils.

If we form the conductor into a coil, the magnetic field produced by each turn of the coil will add up and the coil will behave as an imaginary magnet as shown in Fig. 6.2.

Force of Attraction or Repulsion. Consider a current carrying coil as shown in Fig. 6.2. It produces an imaginary bar magnet. When a piece of soft iron which has not been previously magnetized is brought near the end of the coil, it will be attracted by the coil. Therefore, if we pivot the soft iron on a spindle between two bearings and a coil is mounted near it, the iron piece will swing into the coil when the latter is carrying current. The effect is utilized in the attraction type of moving iron instrument.

If we have two pieces of soft iron placed near the coil the two will be similarly magnetized and there will be force of repulsion between them. This effect is utilized in "repulsion type moving iron instruments."

Force between a Current Carrying Coil and a Permanent Magnet. Consider the coil of Fig. 6.3. It produces an imaginary bar magnet when carrying current. When a permanent magnet is brought near it, there will be either a force of attraction or repulsion. If the coil is mounted on a spindle between bearings, there will be a movement of the coil. This effect is utilized in permanent magnet moving coil instruments.

Force between Two Current Carrying Coils. Consider two current carrying coils shown in Fig. 6.4. For the directions of the currents shown, the two produce unlike

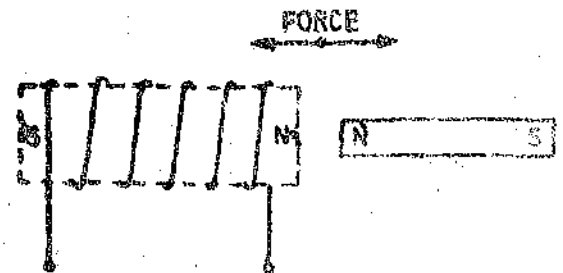

Fig. 6.3. Force between current carrying coil and a permanent magnet.

poles near each other and thus there is a force of attraction and if one of the coils is movable and the other is fixed, there will be a motion of the movable coil.

This effect is utilised in the dynamometer type of instruments.

2. **Thermal Effect.** The current to be measured is passed through a small element which heats it. The temperature rise is converted to an emf by a thermocouple attached to the element.

A thermo-couple consists of lengths of two dissimilar electric conductors joined at ends to form a closed loop. If the junctions of the two dissimilar metals are maintained at different temperatures, a current flows through the closed loop. This current can be measured and is indicative of the r.m.s. value of the current flowing through the heater element.

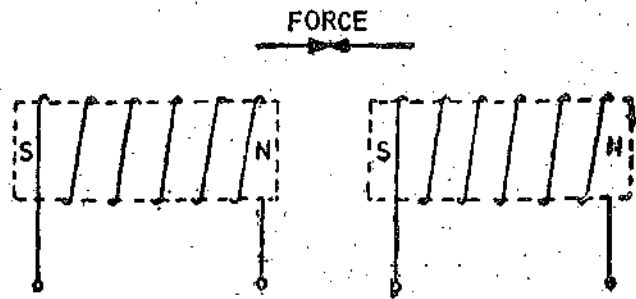

Fig. 6'4. Force between two current carrying coils.

3. **Electrostatic Effect.** When two plates are charged, there is a force exerted between them. This force is used to move one of the plates. The instruments working on this principle are called electrostatic instruments and they are usually voltmeters.

4. **Induction Effect.** When a non-magnetic conducting pivoted disc or a drum is placed in a magnetic field produced by a system of electromagnets excited by alternating currents, an emf is induced in the disc or drum. If a closed path is provided, the emf forces a current to flow in the disc or drum. The force produced by the interaction of induced currents and the alternating magnetic fields makes the disc move. The induction effect is mainly utilized for a.c. energy meters.

5. **Hall Effect.** If a strip of conducting material carries current in the presence of a transverse magnetic field as shown in Fig. 6'5, an emf is produced between two edges of conductor. The magnitude of the voltage depends upon the current, flux density and a property of conductor called "Hall Effect Co-efficient"

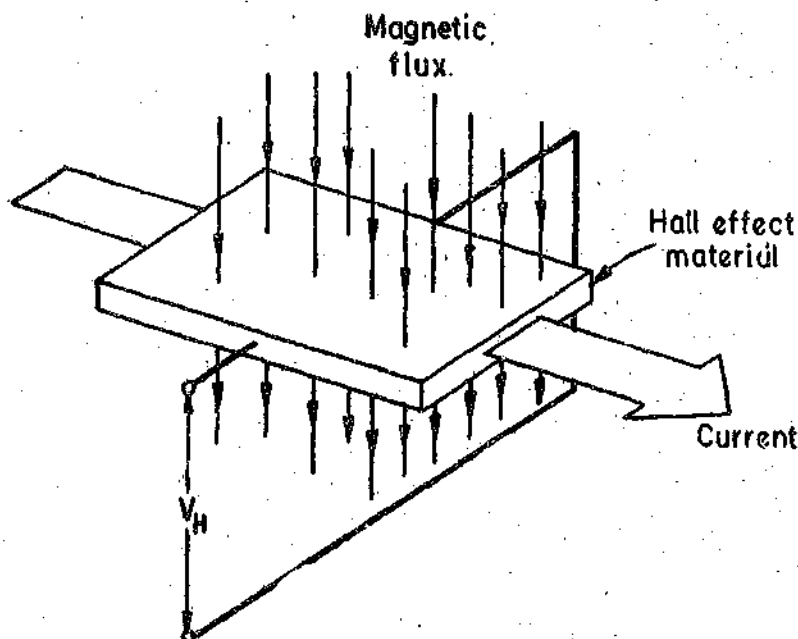

Fig. 6'5. Hall effect element.

The emf may be measured after amplification. Hall effect elements are extensively used in magnetic measurements. They can also be used for sensing of current.

Another instrument that uses Hall effect is Poynting Vector Wattmeter. This wattmeter is used for measuring the power loss density at the surface of a magnetic material.

Table 6.1 gives effects utilized by various types of instruments.

TABLE 6.1

<i>Effect</i>	<i>Instruments</i>
Magnetic effect	Ammeters, voltmeters, wattmeters, Integrating meters.
Heating effect	Ammeters and voltmeters.
Electrostatic effect	Voltmeters.
Induction effect	A.C. ammeters, voltmeters, wattmeters, integrating meters.
Hall effect	Flux meters, ammeters and Poynting vector wattmeter.

ELECTROMECHANICAL INDICATING INSTRUMENTS

6.4. Operating Forces. Three types of forces are needed for the satisfactory operation of any indicating instrument. These are :

- (i) Deflecting force,
- (ii) controlling force,
- and (iii) damping force.

1. Deflecting Force. The deflecting or operating force is required for moving the pointer from its zero position. The system producing the deflecting force is called "Deflecting System" or "Moving System". The deflecting force can be produced by utilizing any of the effects mentioned earlier. Thus the deflecting system of an instrument converts the electric current or potential into a mechanical force called deflecting force. The deflecting system thus acts as the prime mover responsible for deflection of the pointer.

2. Controlling Force. This force is required in an indicating instrument in order that the current produces deflection of the pointer proportional to its magnitude. The system producing a controlling force is called a "Controlling System". The functions of the controlling system are :

(i) to produce a force equal and opposite to the deflecting force at the final steady position of pointer in order to make the deflection of the pointer definite for a particular magnitude of current. In the absence of a controlling system, the pointer will shoot (swing) beyond the final steady position for any magnitude of current and thus the deflection will be indefinite.

(ii) to bring the moving system back to zero when the force causing the instrument to deflect is removed. In the absence of a controlling system the pointer will not come back to zero when current is removed. Controlling force is usually provided by springs.

3. Damping Force. When a deflecting force is applied to the moving system, it deflects and it should come to rest at a position where the deflecting force is balanced by the controlling force.

The deflecting and controlling forces are produced by systems which have inertia and, therefore, the moving system cannot immediately settle at its final position but overshoots or swings ahead of it. Consider Fig. 6'6. Suppose O is the equilibrium or final steady position and because of inertia the moving system moves to position 'a'. Now for any position 'a' beyond the equilibrium position the controlling force is more than the deflecting force and hence the moving system swings back. Due to inertia it cannot settle at 'O' but swings to a position say 'b' behind the equilibrium position. At b , the deflecting force is more than the controlling force and hence the moving system again swings ahead. The pointer thus oscillates about its final steady (equilibrium) position with decreasing amplitude till its kinetic energy (on account of inertia) is dissipated in friction and therefore, it will settle down at its final steady position. If extra forces are not provided to "damp" these oscillations, the moving system will take a considerable time to settle to the final position and hence time consumed in taking readings will be very large. Therefore, damping forces are necessary so that the moving system comes to its equilibrium position rapidly and smoothly without any oscillations.

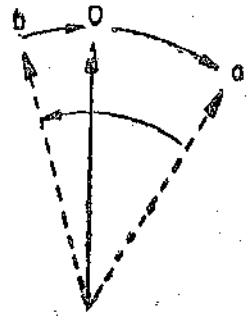

Fig. 6'6

6.5. Constructional Details

Moving System. The requirements of a moving system are that :

- (i) the moving parts should be light (ii) the frictional forces should be minimum.

These requirements should be fulfilled in order that power required by the instrument for its operation is small. (The power expenditure is proportional to the weight of the moving parts and the frictional forces opposing the movement). The moving system can be made light by using aluminium as far as possible. The frictional forces are reduced by using a spindle mounted between jewel bearings and by carefully balancing the system.

Supporting the Moving Element. The force or torque developed by the moving element of an electrical instrument is necessarily small in order that the power consumption of the instrument be kept low so that the introduction of the instrument into a circuit may cause the minimum change in the existing circuit conditions. Because of low power levels, the consideration of various methods of supporting the moving element becomes of vital importance. With the operating forces being small, the frictional forces must be kept to a minimum in order that the instrument reads correctly and is not erratic in action and is reliable.

6'6. Types of Supports. Several types of supports are used, depending upon the sensitivity required and the operating conditions to be met.

Support may be of the following types :

- (i) Suspension (ii) Taut Suspension (iii) Pivot and jewel bearings (double)

1. Suspension. It consists of a fine, ribbon shaped metal filament for the upper suspension and coil of fine wire for the lower part (See Fig. 7'1). The ribbon is made of a spring material like beryllium copper or phosphor bronze. This coiling of lower part of suspension is done in order to give negligible restraint on the moving system. The type of suspension requires careful levelling of the instrument, so that the moving system hangs in correct vertical position. This construction is, therefore, not suited to field use and is employed only in those laboratory applications in which very great sensitivity is required. In order to prevent shocks to the suspension during transit etc. a clamping arrangement is employed for supporting the moving system.

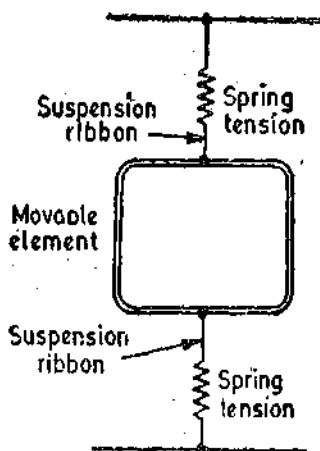

Fig. 6'7. Taut suspension.

2. Taut Suspension. Suspension type of instruments can only be used in vertical position. The taut suspension has a flat ribbon suspension both above and below the moving element, with suspension kept under tension by a spring arrangement (Fig. 6'7). The advantage of this suspension is that exact levelling is not required if the moving element is properly balanced.

Suspensions and taut suspensions are customarily used in instruments of galvanometer class which require a low friction high sensitivity mechanism. But actually there is no strict line of demarcation between

galvanometers and other indicating instruments. Some sensitive wattmeters, and electrostatic voltmeters also use flexible suspension.

Ribbon suspensions, in addition to supporting the moving element, exert a controlling torque when twisted. Thus the use of suspension results in elimination of pivots, jewels and control springs and, therefore, pivotless instruments are free from many defects.

3. Pivot and Jewel Bearings. The moving system is mounted on a spindle made of hardened steel. The two ends of the spindle are made conical and then polished to form pivots. These ends fit conical holes in jewels located in the fixed parts of instruments (Fig. 6'8). These jewels, which are preferably made of sapphire form the bearings. Originally natural sapphire was used but now synthetic sapphire is being used. The combination of steel and sapphire gives lowest friction.

It has been found that the frictional torque, for jewel bearings, is proportional to area of contact between the pivot and jewel. Thus the contact area between pivot and jewel should be small. The pivot is ground to a cone and its tip is rounded to a hemispherical surface of small area. The jewel is ground to a cone of somewhat larger angle. The pivot may have a radius at tips from 0.0125 mm to as high as 0.075 mm depending upon the weight of the mechanism and the force it will encounter. The radius of the pit of jewel is somewhat longer so that the contact is in the form of a circle. The contact area should not be too small otherwise the stress (which is load per unit area) will exceed the crushing strength of the material of pivot. The pivots of many modern instruments are loaded nearly to yield point of steel.

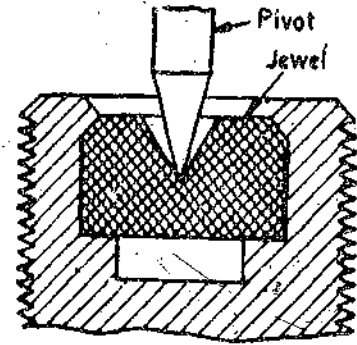

Fig. 6'8. Jewel bearing.

We can have an idea of the stress produced if we consider a moving element weighing 300 mg resting on the area of circle 0.005 mm diameter. The load produces a stress of about $150 \times 10^6 \text{ N/m}^2$ or 1/6 of the crushing limit of the steel. Moreover, if the instruments are subjected to shocks, the dynamic effect may cause the stress to be two or three times or more the static value. It is easy to visualize that rough handling of the instrument may deform the pivot and crack the jewel. Jewels are sometimes spring mounted (Fig. 6'9) to lessen the likelihood of damage because of shocks, and its bottom is also rounded.

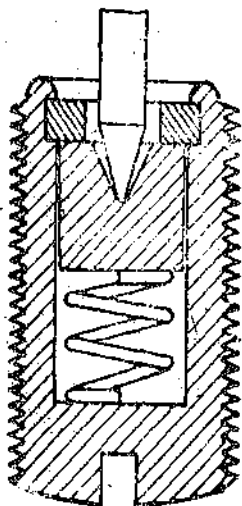

Fig. 6'9. Spring loaded jewel bearing.

Instrument bearings are used dry. Any lubricant, such as oil, would be of questionable value in the first place and would soon cause trouble because of gumming and by collected dust.

It is true to say that good class instruments of this construction are robust and reliable in service, but it is a fact that most instrument defects are due to excessive friction caused by damaged pivots and/or dirty jewel bearings, and due to damaged or distorted control springs.

6.7. Balancing. In order that the wear on the bearing becomes uniform and symmetrical the centre of gravity of weight of moving parts should coincide with axis of the spindle for all positions of pointer and there are no out of balance forces. This also ensures that the deflection is unaffected by the position of the pointer and there are no reading errors.

The balance can be achieved by using balance weights carried on arms attached to the moving system. The use of balance weights is illustrated in Fig. 6'10. The balance weight whose position is adjustable compensates for the weight of pointer and any other thing attached to the moving system.

A cheaper method is to replace balance weights by a wire wound round and soldered to the balance arms. Once fixed, the degree of balance is not adjustable in this case.

When determining the magnitude of weight and the distances at which they are placed, we must consider their effect on the moving system. A small weight at a large distance increases the

moment of inertia and necessitates a large damping torque. A large weight at short distance, on the other hand, increases the weight of moving system. A compromise is usually made.

6.8. Torque/Weight Ratio. The frictional torque in an instrument depends upon the weight of moving parts. If the weight of moving parts is large, the frictional torque will be large. The frictional torque exerts a considerable influence on the performance of an indicating instrument. If the frictional torque is large and is comparable to a considerable fraction of the deflecting torque the deflection of the moving system will depend upon the frictional torque to an appreciable extent. Also the deflection will depend on the direction from which the equilibrium position is approached and will be uncertain. On the other hand, if the frictional torque is very small compared with the deflecting torque, its effect on deflection is negligible. Thus the ratio of deflecting torque to frictional torque is a measure of reliability of the instrument indications and of the inherent quality of the design. Hence (deflecting) torque/weight ratio of an instrument is an index of its performance, the higher the ratio, the better will be its performance.

If the deflecting torque is expressed in terms of a force which, acting at a radius of 1 cm, produces full scale deflection, the ratio of this torque to the weight of moving parts should not be less than 0.1 as far as possible.

6.9. Control Systems. The deflecting system of most of the commercial instruments is mounted on a pivoted spindle, the quantity being measured producing a deflecting torque proportional to its magnitude. There are two types of control systems which are used for such a mounted system :

- (i) Gravity control.
- (ii) Spring control.

1. Gravity Control. In this type of control, a small weight is placed on an arm attached to the moving system. The position of this weight is adjustable. This weight produces a controlling torque due to gravity.

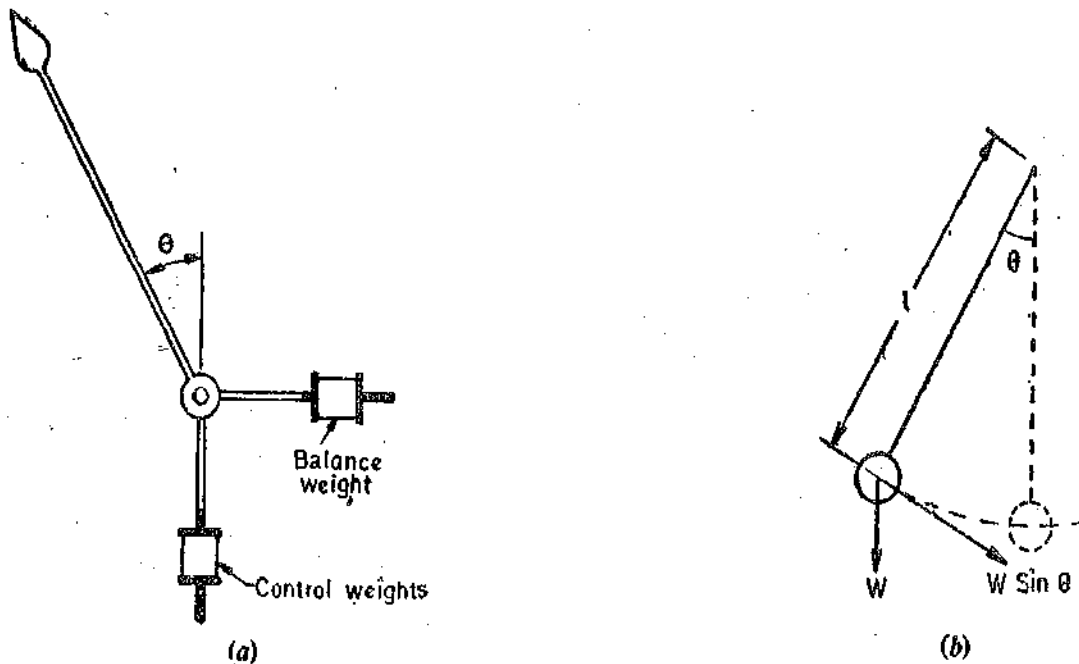

Fig. 6.10. Gravity Control.

Fig. 6.10(a) shows the pointer at zero position. In this case the control torque is zero. Suppose the system deflects through an angle θ as shown in Fig. 6.10(b). The weight acts at a distance l from the centre, the component of weight trying to restore the pointer back to zero position is $W \sin \theta$. Therefore, controlling torque is :

$$T_c = W \sin \theta \times l = Wl \sin \theta \quad \dots(6.1)$$

$$= K_g \cdot \sin \theta \quad \dots(6.2)$$

where

$$K_g = Wl = \text{a constant.}$$

Thus the controlling torque is proportional to sine of angle of deflection of moving system. The controlling torque can be varied by simply adjusting the position of control weight upon the arm which carries it.

It is obvious that the instruments employing gravity control must be used in vertical position in order that the control may operate. The instruments must be mounted in level position otherwise there will be a very serious zero error. For these reasons, gravity control is not suited for indicating instruments in general and portable instruments in particular. The system is obsolete now.

2. **Spring Control.** A hair spring attached to the moving system (Fig. 6'11) exerts a controlling torque. The essential requirements for instrument springs are :

(i) They should be non-magnetic. (ii) They should be proof from mechanical fatigue.

(iii) Where springs are used to lead current into moving system they should have a small resistance, their cross-sectional area must be sufficient to carry the current without a temperature rise which effects their constant. They should also have a low resistance temperature co-efficient.

A number of non-magnetic materials like silicon bronze, hard rolled silver or copper, platinum silver, platinum-iridium and German silver have been used but have not been found satisfactory owing to some reason or the other. For most applications phosphor bronze has been the most suitable material except in instruments of low resistance (like millivoltmeters). In this case some special bronze alloys having low resistance may be used with some sacrifice in mechanical quality.

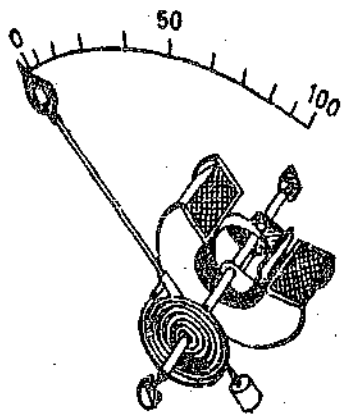

Fig. 6'11. Spring Control.

Flat spiral springs are used in almost all indicating instruments as the space required by these springs is less than for other types.

One form of control spring mounting is shown in Fig. 6'11. The inner end of the spring is attached to the spindle and the outer end carries a spigot which engages in a circular disc surrounding the jewel screw. This disc carries an arm which is slotted and splayed out at the end. The purpose of slotted extension arm is to allow the spring to be coiled or uncoiled slightly, so that the pointer may be set at zero. The slotted arm is actuated by a set screw mounted at the front of instrument and, therefore, zero setting of the instrument can be done without removing the cover.

By making the number of turns large, the deformation per unit length is kept small on full scale deflection. The controlling torque is thus made proportional to the angle of deflection of the moving system.

For a flat spiral spring, the controlling torque developed by deflection is :

$$T_c = \frac{E b t^3}{12l} \theta \text{ N-m} \quad \dots(6'3)$$

where E = Young's modulus of spring material ;
N/m²,

b = width of spring ; m,

t = thickness of spring ; m,

l = length of spring ; m,

θ = angular deflection ; rad.

E, b, t, l are constant for a particular spring.

$$\therefore T_c = K\theta \quad \dots(6'4)$$

$$\text{where } K = \frac{E b t^3}{12l} \text{ N/rad} \quad \dots(6'5)$$

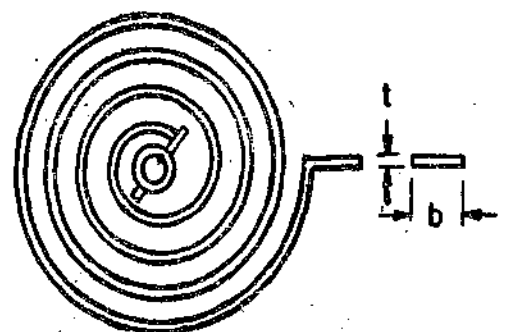

Fig. 6'12. Flat spiral spring.

= a constant called "spring constant" or control constant or "torsion constant" or "restoring constant".

The springs should be stressed well below their elastic limit at maximum deflection of the instrument in order that there is no permanent set or that no change in deflection (or zero shift) will occur from inelastic yield.

$$\text{Maximum fibre stress} \quad f_{max} = \frac{6T_c}{bt^2} \text{ N/m}^2 \quad \dots(6'6)$$

$$\text{Combining Eqns. 6'3 and 6'6, we have } \frac{l}{t} = \frac{E}{f_{max}} \cdot \frac{\theta}{2} \quad \dots(6'7)$$

For phosphor bronze, the maximum allowable stress is $f_{max} = 30 \text{ MN/m}^2$, and $E = 120 \text{ GN/m}^2$

$$\text{From this,} \quad \frac{l}{t} = \frac{120 \times 10^9}{30 \times 10^6} \cdot \frac{\theta}{2} = 2000 \theta.$$

$$\text{Therefore, for a full scale deflection of } \theta = \frac{\pi}{2}, \quad \frac{l}{t} = 3000.$$

Hence in order that the material is not over-stressed the ratio of length to thickness of the spring strip should not be much less than 3000. Some designers use a ratio as low as 2100 (for a maximum deflection of 90°) for portable instruments. For switchboard instruments, whose indications are of lower precision, a ratio as low as 1000 is sometimes used. The ratio b/t may be as high as 30/1 but is generally greater than 10/1.

Fatigue in springs may be avoided to a great extent by proper annealing and ageing during manufacture.

In order to eliminate the effect of temperature variations upon the length of the spring, two springs coiled in opposite directions are used. When the moving system deflects, one spring is extended while the other is compressed.

Comparison between Spring and Gravity Control. The disadvantages of gravity control have been mentioned earlier. Its advantages, when compared with spring control, are :

- (i) It is cheap.
- (ii) The control is independent of temperature variations.
- (iii) It does not deteriorate with time.

Let us see the effect of the two types of controls on shape of the scale. Consider an instrument in which the deflecting torque is directly proportional to current being measured.

Therefore, deflecting torque $T_d = K_a I$

where I = current being measured and K_a = a constant.

If the instrument is spring controlled, the controlling torque $T_c = K\theta$

where θ = angle of deflection and K = spring constant.

At the equilibrium position, the deflecting torque is equal to the controlling torque or $T_c = T_d$.

$$\text{or } K\theta = K_a I \quad \therefore \theta = \frac{K_a}{K} I = K_2 I$$

$$\text{where } K_2 = \text{a constant} = \frac{K_a}{K}.$$

Therefore, the deflection is directly proportional to current (the quantity being measured) throughout the whole range of scale.

If the instrument is gravity controlled $T_c = K_p \sin \theta$,

For equilibrium position $T_c = T_d$ or $K_g \sin \theta = K_d I$

$$\text{or} \quad \sin \theta = \frac{K_d}{K_g} I = K_2' I \quad \therefore \theta = \sin^{-1} (K_2' I)$$

Suppose a current I_{max} produces a deflection of 90° in both the cases, then a current of $I_{max}/2$ would produce a deflection of 45° in the spring controlled instrument. If gravity control is employed, we have

$$\begin{aligned} \sin 90^\circ &= K_2' I_{max} & \text{or} & \quad K_2' = 1/I_{max} \\ \therefore \text{when} & & I &= I_{max}/2, \quad \theta = \sin^{-1} K_2' I = \sin^{-1} [(1/I_{max})(I_{max}/2)] \\ & & & = \sin^{-1} (0.5) = 30^\circ. \end{aligned}$$

Thus, while a current I_{max} gives a deflection of 90° , a current of $I_{max}/2$ gives a deflection of 30° . This means that a gravity controlled instrument does not give a uniform scale.

Hence a gravity control, taken on its merit, gives a cramped (compressed or crowded) scale at the lower end. This is a disadvantage when the pointer lies at the lower scale values, as these will not be accurately read.

Example 6.1. The control spring of an instrument has the following dimensions :

Length of strip = 370 mm ; thickness of strip = 0.073 mm, width of strip = 0.51 mm

The Young's modulus is 112.8 GN/m^2 . Estimate the torque exerted by spring when it is turned through 90° .

Solution. From Eqn. 6.3, the controlling torque $T_c = \frac{Ebt^3}{12l} \theta$

$$\begin{aligned} &= \frac{112.8 \times 10^9 \times (0.51 \times 10^{-3}) \times (0.073 \times 10^{-3})^3 \times \frac{\pi}{2}}{12 \times 370 \times 10^{-3}} = 7.9 \times 10^{-9} \text{ Nm.} \end{aligned}$$

Example 6.2. The deflecting torque corresponding to a deflection of 60° is $100 \times 10^{-6} \text{ Nm}$ in an instrument. The control is exerted through two phosphorus bronze springs. Allowing a maximum stress of 65 MN/m^2 and taking the value of modulus of elasticity as 112.8 GN/m^2 , calculate suitable dimensions for control springs. The width of spring strip is 1 mm.

Solution. There are two springs and, therefore, each spring exerts a controlling torque which is half of the deflecting torque.

$$\therefore \text{Controlling torque of each spring } T_c = \frac{1000 \times 10^{-6}}{2} = 500 \times 10^{-6} \text{ Nm.}$$

$$\text{From Eqn. 6.6, maximum stress } f_{max} = 6 \frac{T_c}{bt^2}$$

$$bt^2 = \frac{T_c}{f_{max}} = \frac{6 \times 500 \times 10^{-6}}{65 \times 10^{-6}} = 46.2 \times 10^{-12} = 0.046 \text{ mm}^3$$

$$\text{Width of spring } b = 1 \text{ mm, so } t^2 = \frac{0.046}{1} = 0.046 \text{ mm}^2.$$

$$\therefore \text{Thickness of spring } t = 0.214 \text{ mm}$$

$$\text{Deflection } \theta = 60^\circ = \pi/3 \text{ radian}$$

$$\text{From Eqn. 6.3, controlling torque } T_c = \frac{Ebt^3}{12l} \theta \quad \text{or length of spring } l = \frac{Ebt^3}{12T_c} \theta$$

$$= \frac{12.8 \times 10^9 \times (1 \times 10^{-3}) \times (0.214 \times 10^{-3})^3 \times \frac{\pi}{3}}{12 \times 500 \times 10^{-6}} = 0.192 \text{ m} = 192 \text{ mm,}$$

Example 6'3. The deflecting torque of an ammeter varies as the square of the current passing through it. If a current of 5 A produces a deflection of 90° , what deflection will occur for a current of 3 A when the instrument is :

- (i) Spring controlled (ii) Gravity controlled.

Comment upon the results.

Solution : The deflecting torque varies as square of current

$$\therefore T_d = K_d I^2$$

- (i) *Spring control :*

In spring controlled instruments, the controlling torque is proportional to deflection

or $T_c = K \theta$.

For equilibrium position, $T_c = T_d$

or $K\theta = K_d I^2$ or $\theta = \frac{K_d}{K} I^2$.

Let the deflections for currents I_1 and I_2 be θ_1 and θ_2 respectively.

$$\therefore \frac{\theta_1}{\theta_2} = \frac{I_1^2}{I_2^2} \quad \text{or} \quad \theta_2 = \theta_1 (I_2/I_1)^2$$

\therefore Deflection produced by a current of 3 A, $\theta_2 = 90^\circ \times (3/5)^2 = 32.4^\circ$.

- (ii) *Gravity control*

For gravity controlled instruments the controlling torque is proportional to sine of angle of deflection.

$$\therefore T_c = K_g \sin \theta$$

Proceeding as above $\frac{\sin \theta_1}{\sin \theta_2} = \frac{I_1^2}{I_2^2}$

or $\sin \theta_2 = \sin \theta_1 \times (I_2^2/I_1^2) = \sin 90^\circ \times (3/5)^2 = 0.36 \quad \therefore \theta_2 = \sin^{-1} 0.36 = 21.1^\circ$.

The scale is non-uniform for both the cases. This is due to deflecting torque being proportional to square of quantity being measured. However, the scale is more cramped at the lower end in the case of gravity control.

Example 6'4. A weight of 5 g is used as the controlling weight in a gravity controlled instrument. Find its distance from spindle if the deflecting torque corresponding to a deflection of 60° is 1.13×10^{-3} Nm.

Solution : Deflecting torque due to a weight is $T_d = mg \sin \theta \times d$

where $d =$ distance of the weight from spindle.

$$\therefore d = \frac{T_d}{mg \sin \theta} = \frac{1.13 \times 10^{-3}}{5 \times 10^{-3} \times 9.81 \times \sin 60^\circ} = 0.0266 \text{ m} = 26.6 \text{ mm.}$$

6'10. Damping Systems. The damping torque should be of such a magnitude that the pointer quickly comes to its final steady position, without overshooting.

If the instrument is underdamped, the moving system will oscillate about the final steady position with a decreasing amplitude and will take some time before it comes to rest.

When the moving system moves rapidly but smoothly to its final steady position, the instrument is said to be critically damped or dead beat.

If the damping torque is more than what is required for critical damping, the instrument is said to be overdamped. In an overdamped instrument, the moving system moves slowly to its final steady position in a lethargic fashion. The readings are very tedious to take.

Fig. 6'13 illustrates the way an underdamped, an overdamped and a critically damped system moves to its final steady position.

The damping device should be such that it produces a damping torque only while the moving system is in motion. To be effective the damping torque should be proportional to the velocity of the moving system but independent of the operating current. It must not effect the controlling torque or increase the static friction.

The methods for producing damping torque are :

- (i) air friction damping,
- (ii) fluid friction damping,
- (iii) eddy current damping and (iv) electromagnetic damping.

1. **Air Friction Damping.** Two types of air friction damping devices are shown in Fig. 6'14.

The arrangement of Fig. 6'14 (a), consists of a light aluminium piston which is attached to the moving system. This piston moves in a fixed air chamber which is closed at one end. The clearance between piston and chamber walls is uniform throughout and is very small. When there are oscillations the piston moves into and out of an air chamber. When the piston moves into the chamber, the air inside is compressed and the pressure of air, thus built up, opposes the motion of piston and hence of whole of the moving system. When the piston moves out of air chamber, pressure in the closed space falls, and the pressure on the open side of piston is greater than on the other side. Thus there is again an opposition to motion.

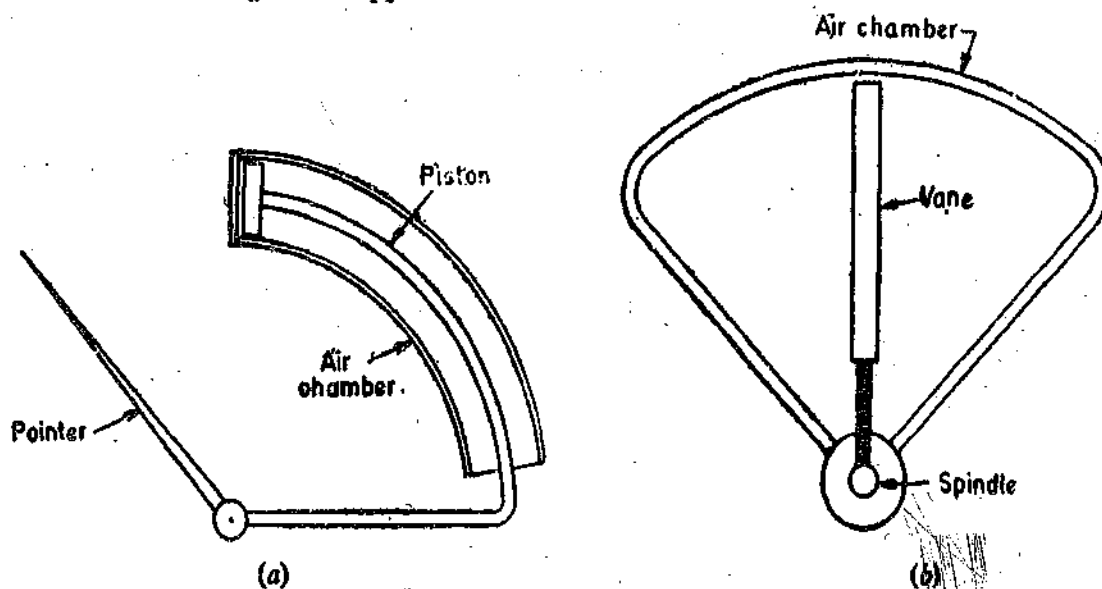

Fig. 6'14. Air friction damping.

The arrangement of Fig. 6'14 (b), consists of an aluminium vane which moves in a quadrant (sector) shaped air chamber. This air chamber is a recess cast in a bakelite moulding or diecasting. The chamber is completed by providing a cover plate at the top. The aluminium piston should be carefully fitted so that it does not touch the wall otherwise a serious error will be caused in readings.

2. **Fluid Friction Damping.** This form of damping is similar to air friction damping. Oil is used in place of air and as the viscosity of oil is greater, the damping force is also correspondingly greater.

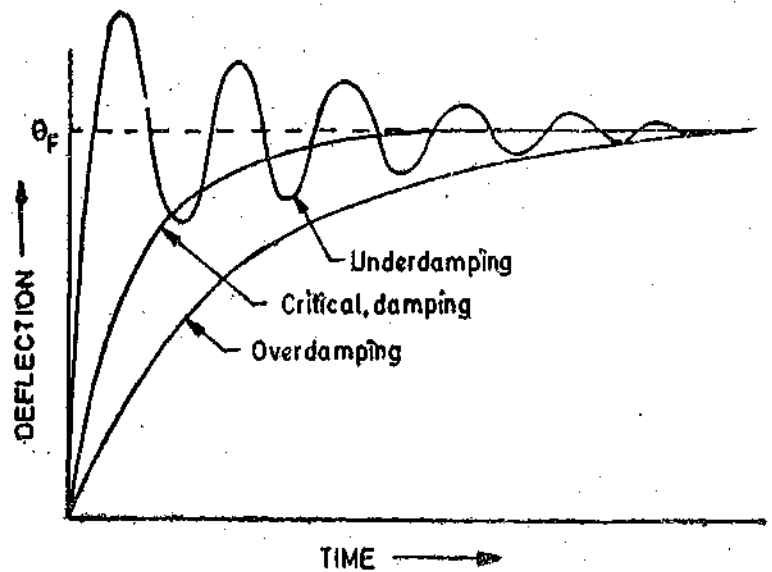

Fig. 6'13. Damping.

A disc is attached to the moving system [Fig. 6'15 (a)], this disc dips into an oil pot and is completely submerged in oil. When the moving system moves, the disc moves in oil and a frictional drag is produced. This frictional drag always opposes the motion.

In the arrangement shown in Fig. 6'15(b), a number of vanes are attached to the spindle. These vanes are submerged in oil and move in a vertical plane. This arrangement gives a greater damping torque.

3. Eddy Current Damping. This is also known as electromagnetic damping. When a conductor moves in a magnetic field an emf is induced in it and if a closed path is provided, a current (known as eddy current) flows. This current interacts with the magnetic field to produce an electromagnetic torque which opposes the motion. This torque is proportional to the strength of the magnetic field and the current produced. The current is proportional to emf which in turn is proportional to velocity of the conductor. Thus if the strength of the magnetic field is constant (if it is produced by a permanent magnet), the torque is proportional to velocity of the conductor.

4. Electromagnetic Damping. The movement of a coil in a magnetic field produces a current in the coil which interacts with the magnetic field to produce a torque. This torque opposes the movement of the coil and slows the response. The magnitude of the current and hence the damping torque is dependent upon the resistance of the circuit to which the instrument is connected. The electromagnetic damping is used in galvanometers.

Comparison of Methods of Damping. Air friction damping provides a very simple and cheap method of damping. But care must be taken to see that the piston is not bent or twisted otherwise it will touch the walls of the air chamber thereby causing serious errors due to solid friction which is thus introduced. This method is used in hot wire and moving iron instruments.

Fluid friction damping has the advantage that the oil which is required for damping, can be used for insulation purposes in some forms of instruments which are submerged in oil. A vane moving in oil instead of air does not require the same small clearances to give effective damping and therefore this method is suitable for instruments such as electrostatic type where the movement is suspended rather than pivoted. Another advantage of fluid friction damping is that due to the upthrust of oil, the load on bearings or suspension is reduced thus reducing frictional errors.

The disadvantages of fluid friction damping are that it can be used only for instruments which are in vertical position. Also because of creeping of oil, the instruments cannot be kept clean. Hence this type of damping can be used for laboratory type electrostatic instruments and there are obvious difficulties in the way of its application to portable instruments.

Eddy current damping is the most efficient form of damping. It is very convenient to use in instruments where a metallic disc or a former and a permanent magnet already form part of the operating system. For these reasons this method is used in hot wire, moving coil and induction type instruments. This method cannot be used in instruments where introduction of a permanent magnet required for producing eddy currents will distort the existing magnetic field.

There are two common forms of damping devices :

- (i) A metal former which carries the working coil of the instrument.
- (ii) A thin aluminium disc attached to the moving system of the instrument. This disc moves in the field of a permanent magnet.

6'11. Eddy Current Damping Torque of Metal Former. Fig. 6'16 shows a metallic former moving in the field of a permanent magnet.

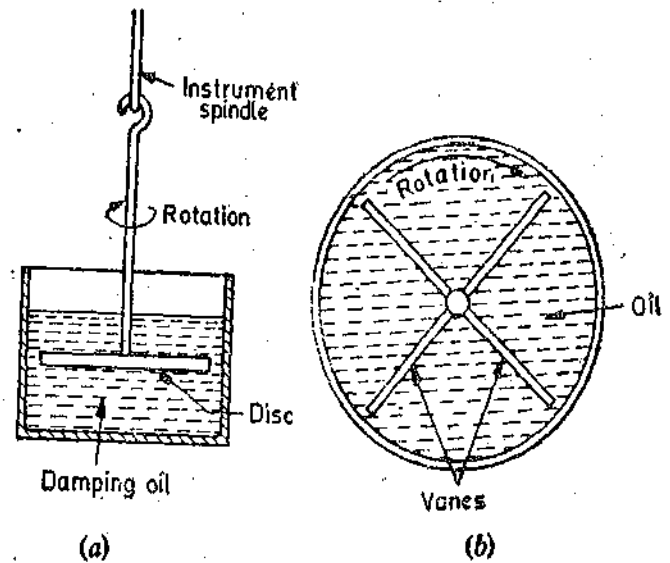

Fig. 6'15. Fluid Friction Damping.

Let B = strength of magnetic field ; Wb/m^2 ,
 ω = angular speed of former ; rad/s ,
 l = length of former ; m ,
 t = thickness of former ; m ,
 b = width of former ; m ,
 d = breadth of former ; m ,
 ρ = resistivity of material of former, $\Omega \text{ m}$.

Linear velocity of former $v = \frac{d}{2} \omega$.

Emf generated in the former

$$= 2 \times Bld \frac{\omega}{2} = Bld\omega$$

Resistance of path of eddy currents

$$R_e = \frac{\text{resistivity} \times \text{length}}{\text{area}} = \frac{\rho \times 2(l+d)}{b \times t} = \frac{2\rho(l+d)}{bt}$$

Eddy current

$$I_e = \frac{E_e}{R_e} = \frac{Bl d\omega}{2\rho(l+d)/bt} = \frac{Bl bt d\omega}{2\rho(l+d)}$$

$$\therefore \text{Damping force } F_D = BIl = B \times \frac{Bl bt d\omega}{2\rho(l+d)} \times l = \frac{B^2 l^2 bt d\omega}{2\rho(l+d)} \text{ newton} \quad \dots(6.8)$$

$$\text{Damping torque } T_D = F_D \times d = \frac{B^2 l^2 bt d\omega}{2\rho(l+d)} \times d = \frac{B^2 l^2 d^2 bt\omega}{2\rho(l+d)} \text{ newton metre} \quad \dots(6.9)$$

$$\text{Damping constant } K_D = \frac{T_D}{\omega} = \frac{B^2 l^2 d^2 bt\omega}{2\rho(l+d) \omega} = \frac{B^2 l^2 d^2 bt}{2\rho(l+d)} \text{ Nm/rad s}^{-1} \quad \dots(6.10)$$

It is clear from above that the damping torque can be varied by changing t , the thickness of metal former.

6.12. Damping Torque of a Metal Disc. Let
 B = flux density of magnetic field ; Wb/m^2 ,
 t = thickness of metallic disc ; m ,
 b = width of permanent magnet ; m ,
 d = depth of permanent magnet ; m ,
 ρ = resistivity of material of disc ; Ωm ,
 ω = angular speed of disc ; rad/s .

It is not possible to attempt an exact solution of the problem and hence only an approximate solution is given.

Considering the emf induced in the portion under the pole face. Let

R = radius measured from centre of pole to centre of disc ; m .

\therefore Emf induced in the portion below the magnet $E_e = Blv = BdR\omega$

Resistance of eddy current path under the

$$\text{pole} = \frac{\rho d}{bt}$$

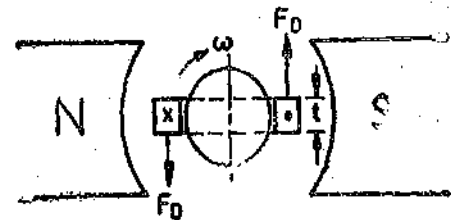
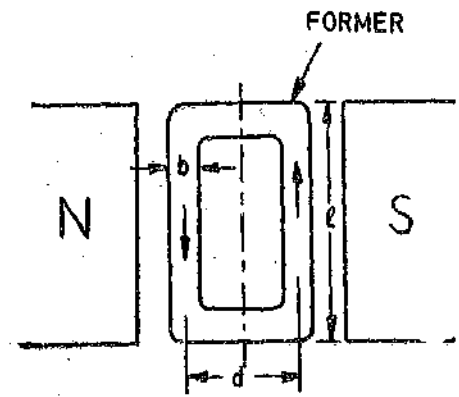

Fig. 6.16 Eddy current damping by metal former.

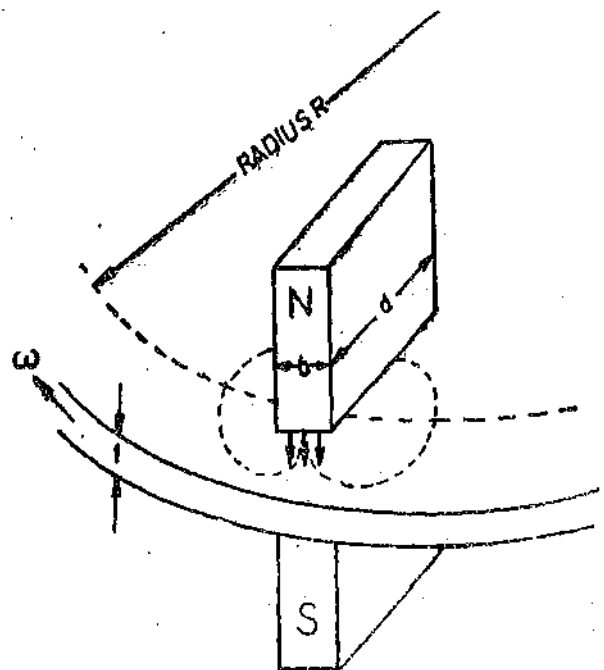

Fig. 6.17. Eddy current damping by metallic disc.

Actual path of eddy current is not limited to the portion of the disc under the magnet but is greater than this

Therefore to take this factor into account the actual resistance is taken as K times $\rho d/bt$.

$$\therefore \text{Resistance of eddy current path } R_e = \frac{K \rho d}{b t}$$

where

$K =$ a constant which depends upon radial position of poles.

$$\text{Eddy current } I_e = \frac{E_e}{R_e} = \frac{B d R \omega}{K \rho d/bt} = \frac{B R b t \omega}{K \rho}$$

$$\text{Damping force } F_D = B \times \frac{B R b t \omega}{K \rho} \times d = \frac{B^2 R d b t \omega}{K \rho} \text{ newton} \quad \dots(6'11)$$

$$\text{Damping torque } T_D = \frac{B^2 R^2 d b t \omega}{K \rho} \text{ newton metre} \quad \dots(6'12)$$

$$\text{Damping constant } K_D = \frac{T_D}{\omega} = \frac{B^2 R^2 d b t}{K \rho} \text{ Nm/rad s}^{-1} \quad \dots(6'13)$$

From Eqn. 6'12, it is clear that the damping torque can be changed by changing R , i.e., the radial position of poles with respect to the centre of the disc.

6'13. Permanent Magnets. Permanent magnets are made of hard materials, i.e., materials which have a broad hysteresis loop (large co-ercive force) so that they are not subject to self-demagnetization.

In order that the volume of the permanent magnet is small, the product $(BH)_{max}$ of the material used should be large.

Two general groups of the permanent magnet materials are the "old type" such as carbon steel, and other steel alloys that contain chromium, tungsten and cobalt; and the "new type" such as aluminium nickel cobalt alloys like Alnico, Alini, Alcomax etc. which are extremely hard and must be produced by sintering and ceramic magnets of which barium ferrite is the chief constituent. Table 6'2 gives the data for magnetic materials used for permanent magnets.

TABLE 6'2.
Permanent Magnet Materials

Material	Remenance Wb/m^2	Co-ercive force A/m	Value of B for $(BH)_{max}$	Value of H for $(BH)_{max}$	$(BH)_{max}$
10% Carbon steel	0.9	4,000	0.6	2,600	1,560
6% Tungsten steel	1.05	5,200	0.7	3,750	2,625
35% Cobalt steel	0.9	20,000	0.6	13,000	7,800
Alnico	0.8	40,000	0.56	24,000	13,500
Alini	0.55	46,000	0.36	28,000	10,000
Alcomax III	1.25	54,000	0.95	40,000	38,000
Alcomax IV	1.1	60,000	0.8	43,000	34,400

One of the major requirements of a permanent magnet are that its strength should not change with time, i.e., there should be no ageing effects.

6.14. Pointers and Scales. Instrument scales and pointers may be considered together in two classes :

(i) those intended for reading quickly (in the case of switchboard instruments at a distance), and

(ii) those intended for close accurate reading.

However, in all cases, the weight and inertia of pointer must be reduced so as to reduce the load on the bearing and to avoid necessity of excessive damping torque.

The pointer motion is limited by buffers or stops to a little more than the scale. These stops are constructed as very light springs so that the pointer is not bent when it strikes them sharply on a sudden overload or reversal of the operating current

Switchboard and Panel Instruments. Measuring instruments for switchboards have a square or a rectangular front. The pointers and scales for these instruments should be so that the position of the pointer is conspicuous, the scale markings are legible and there is contrast with the background. Pointers are usually broad or carry broad targets at their ends. Aluminium strip or tube is used for making pointers and 'A' type of construction is used to give rigidity.

The scale is generally printed on the enamelled surface of a metal plate or on paper or card board pasted to a metal plate. Scale markings are usually broad.

Portable Instruments. Portable instruments usually have knife edge pointer moving over scale marked with fine lines, usually not wider than knife edge may be formed by flattening the end of a light aluminium tube or it may be a thin flat strip carried at the end of the pointer. If the pointer and scale are in different planes, observational errors may result on account of parallax. The errors due to parallax arise due to the line of sight being in an oblique plane direction. The parallax errors can be avoided by using knife edge pointers and scales mounted in the same plane as the tip of pointer.

6.15. Recording Instruments

Recording instruments are used at places where a continuous record of circuit conditions is required. This record may be used for future reference or computation work.

The indicating instruments described earlier give a continuous indication of the measurand, but they require the presence of an operator to observe variations in magnitude of readings. With the ever-increasing emphasis on automation, continuously recording instruments, in particular those designed to record permanently the variations in the quantity, are finding many applications.

To cite an example a particular type of recording instrument is obtained by modifying the construction of an indicating instrument. This is done by replacing the pointer and scale of the normal indicating instrument by a light arm carrying an ink pen. The ink pen deflects to give an ink record on a paper chart which is wound at a constant speed by a clockwork mechanism from one roller or drum to another, or by a small synchronous motor run from the mains. The path traced out by the pen gives a continuous record of the variations of deflection of the instrument.

The different types of recording instruments are described in a subsequent chapter.

6.16. Integrating Instrument:

These instruments are used to measure and register total energy being supplied to a circuit in a given interval of time. This is done irrespective of the rate at which energy is consumed.

A watt-hour meter is an example of Integrating type instruments.

Watt hour meters. Watt hour meters measure the energy supplied to a circuit directly in watt hour. These meters are provided with a circuit which is excited by the voltage and, therefore, the operating torque is in part, due to a current proportional to the supply voltage.

Integrating meters can be classified as : (i) Clock type (ii) Motor type.

(i) **Clock Meters.** They consist of a clock mechanism having two pendulums. There are two

sets of coils, one energised by the current carried by the load and the other by the voltage across the load. The current coils are fixed but the voltage coils are carried by the pendulums. The pendulums are subjected to magnetic pull when swinging past the fixed coils. This interaction causes one pendulum to accelerate and the other to retard. The resulting difference in time period of the two pendulums is made to give an indication proportional to the energy.

Clock meters are very costly and are seldom used.

(ii) **Motor Meters.** These meters are universally used for measurement of energy. The motor meters consist of three main parts which differ in detail according to the underlying principle of the motoring action utilized, which may be similar to that of a simple a.c. or d.c. motor.

These parts are :

(i) **Operating System.** This produces a torque proportional to the current or power and makes the moving system rotate.

(ii) **Braking system**—This produces a braking torque proportional to the speed of the rotation and thus causes the meter to run at a steady speed. The speed is such that the braking torque is equal to the operating torque. The braking torque is generally provided by eddy currents induced in a metallic disc moving in the field of a permanent magnet.

(iii) **Registering system**—The moving system is carried on a spindle. The spindle has a worm cut out on it and this worm engages a train of wheels with the help of a pinion. These wheels are caused to rotate when the spindle rotates. The spindles of the wheels in the train carry hands which move over the dials which register units, tens, hundreds and so on.

UNSOLVED PROBLEMS

1. An instrument spring made of phosphor bronze strip has a length of 400 mm, a width of 0.5 mm and a thickness of 0.08 mm. If the modulus of elasticity of phosphor bronze is taken as 120 GN/m^2 , estimate the torque exerted by the spring for a deflection of (a) 60° (b) 90° . [Ans $6.7 \times 10^{-6} \text{ N-m}$, $10 \times 10^{-6} \text{ N-m}$]

2. The control torque of an indicating instrument is exerted by two flat springs. The full scale torque is $40 \times 10^{-6} \text{ Nm}$ for a deflection of 90° . The modulus of elasticity and the maximum stress for the spring material are 100 GN/m^2 and 20 MN/m^2 respectively. Calculate the number of turns required, and the thickness of one spring if its width is $7.5 \times 10^{-3} \text{ mm}$ and its mean diameter is 110 mm. [Ans. 10.61 ; 0.894 mm]

3. A permanent magnet moving coil instrument has a full scale deflection of 90° for a current of 2 A. Find the current required for a deflection of 30° if the instrument is (i) spring controlled, (ii) gravity controlled.

[Ans. i) 0.67 A (ii) 1 A]

Galvanometers

71. Introduction. A galvanometer is an instrument used for detecting presence of small currents or voltages in a closed circuit or for measuring their magnitudes. Galvanometers find their principal application in bridge and potentiometer measurements where their function is to indicate zero current. Therefore, a galvanometer in addition to being sensitive, should have a stable zero, a short periodic time and nearly critical damping.

72. D'Arsonval Galvanometer. This instrument is very commonly used in various methods of resistance measurement and also in d.c. potentiometer work.

73. Construction of d'Arsonval Galvanometer

The construction of a d'Arsonval Galvanometer is shown in Fig. 71.

1. Moving Coil: It is the current carrying element. It is either rectangular or circular in shape and consists of a number of turns of fine wire. This coil is suspended so that it is free to turn about its vertical axis of symmetry. It is arranged in a uniform, radial, horizontal magnetic field in the air gap between pole pieces and armature (iron core) of a permanent magnet. The armature (iron core) is spherical in shape if the coil is circular but is cylindrical if the coil is rectangular. The length of air gap is about 1.5 mm. In some galvanometers the iron core is omitted and the coil is made narrow to decrease the air gap. Such a galvanometer is less sensitive, but its moment of inertia is smaller and the periodic time shorter.

2. Damping. There is a damping torque present owing to production of eddy currents in the metal former on which the coil is mounted. Damping is also obtained by connecting a low resistance across the galvanometer terminals. Damping torque depends upon the resistance and we can obtain critical damping by adjusting the value of resistance as explained later in this chapter.

3. Suspension. The coil is supported by a flat ribbon suspension which also carries current to the coil. The other current connection in a sensitive galvanometer is a coiled wire. This is called the lower suspension and has a negligible torque effect. This type of galvanometer must be levelled carefully so that the coil hangs straight and centrally without rubbing the poles or the soft iron cylinder. Some portable galvanometers which do not require exact levelling have "taut suspensions" consisting of straight flat strips kept under tension for both top and bottom.

The upper suspension consists of gold or copper wire of nearly 0.0125 or 0.025 mm diameter rolled into the form of a ribbon. This is not very strong mechanically, so that the galvanometers

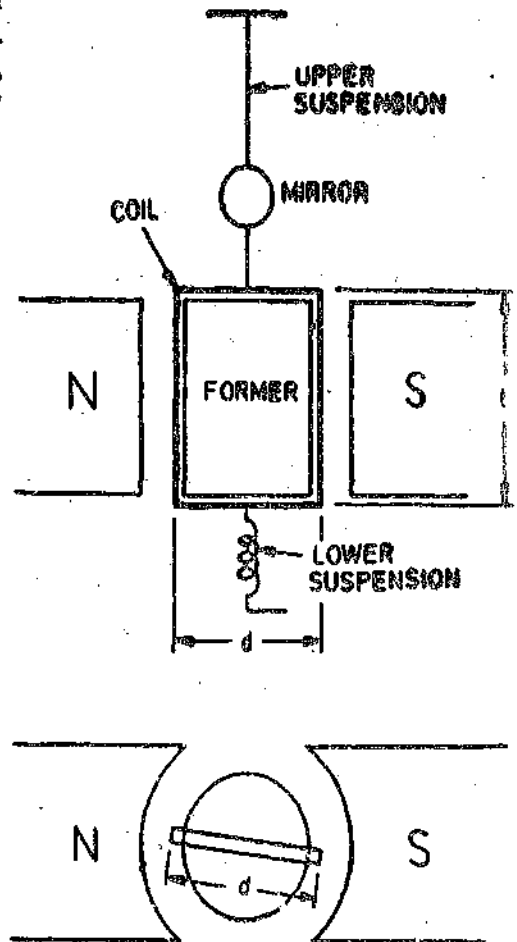

Fig. 71. d'Arsonval Galvanometer.

must be handled carefully without jerks. Sensitive galvanometers are provided with coil clamps to take the strain from suspension while the galvanometer is being moved.

4. Indication. The suspension carries a small mirror upon which a beam of light is cast. The beam of light is reflected on to a scale upon which the deflection is measured. This scale is usually about 1 metre away from the instrument, although 1/2 metre may be used for greater compactness.

5. Zero Setting. A torsion head is provided for adjusting the position of the coil and also for zero setting.

7.4. Torque Equation. Fig. 7.1 shows the dimensions that enter the torque equation of a galvanometer.

- Let l = length of vertical side of coil ; m,
- d = length of horizontal side (width) of coil ; m,
- N = number of turns in the coil,
- B = flux density in the air gap at the coil position ; Wb/m²,
- i = current ; A,
- K = spring* constant of suspension ; Nm/rad,
- θ_F = final steady deflection ; rad.

Force on each side of coil = $NBil \sin \alpha$

where α = angle between direction of magnetic field and the conductor.

The field is radial and, therefore, $\alpha = 90^\circ$

Hence, force on each side = $NBil$

Deflecting torque $T_d = \text{force} \times \text{distance} = NBild$... (7.1)

$= NBAi$ newton metre ... (7.2)

$A = ld = \text{area of coil ; m}^2.$

where

N, B, A are constants for a galvanometer.

\therefore Deflecting torque $T_d = Gi$ newton metre ... (7.3)

$G = NBA = NBld$... (7.4)

where

G is called the displacement constant of the galvanometer.

Controlling torque exerted by the suspension at deflection θ_F , is $T_c = K\theta_F$

For final steady deflection, $T_c = T_d$ or $K\theta_F = Gi$

Hence $\theta_F = \frac{Gi}{K}$ radian. ... (7.5)

If the deflection is measured on a mm scale kept 1 metre away and if θ_F is small, the deflection d (see Fig. 7.2) is given by :

$d = 0d = \text{radius} \times \text{angle turned by the reflected beam}$
 $= 1000 \times 2\theta_F = 2000 \frac{Gi}{K}$... (7.6)

This is because if the deflection is θ_F , the mirror turns through an angle θ_F while the reflected beam turns through an angle $2\theta_F$.

For a large angle ($2\theta_F$ above 5° to 10°), Eqn. 7.6 is not accurate, and we should write

$d = 1000 \tan 2\theta_F$ mm. ... (7.7)

7.5. Dynamic Behaviour of Galvanometers. We have considered so far the steady state relationship of deflection, current, number of turns and so on.

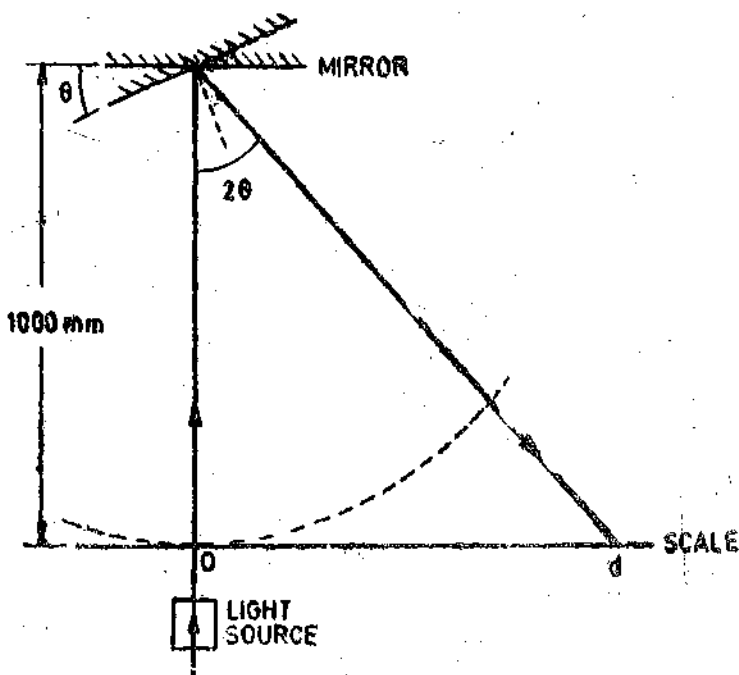

Fig 7.2. Measurement of deflection with lamp and scale arrangement.

*K is known by various names like control constant, restoring constant and stiffness.

When we pass current through a galvanometer it does not reach its steady state deflection immediately but there is a time interval or period of transition during which the moving system of the galvanometer deflects from its initial position to the final steady state position. The dynamic behaviour of the galvanometer during this period is examined by the equation of motion. It should be emphasized here that this equation of motion with suitable modifications of constants, is applicable to most electrical indicating and recording instruments, electromechanical oscillographs and to many instruments of strictly mechanical actuation. In fact it is the most important equation in engineering mathematics. This equation helps us to study the problems relating to speed of response, overshoot and damping.

Let us first consider the constants of a galvanometer. These constants are known as "Intrinsic Constants".

(i) **Displacement Constant.** The deflecting torque is given by $T_d = G\theta$ (See Eqn. 7.3) where G is the displacement constant of the galvanometer and is equal to NBI/d .

The units of G are Nm/A.

(ii) **Inertia Constant.** A retarding torque is produced owing to inertia of moving system. This torque is dependent upon the moment of inertia of moving system and the angular acceleration.

$$\text{Inertia torque} \quad T_i = J \frac{d^2\theta}{dt^2} \quad \dots(7.8)$$

where J = moment of inertia of moving system about the axis of rotation ; kg-m²,
 θ = deflection at any time t ; rad.

J is also called the "inertia constant".

(iii) **Damping Constant.** Damping is provided by the friction due to motion of the coil in the air and also by induced electrical effects if a closed circuit is provided. Damping torque is assumed to be proportional to velocity of the moving system. This is true for electro-magnetic damping and is at least a fair approximation for air damping (which is usually a small part of the total). We shall study damping action in greater detail in Art. 7.15, but for the present we will lump the two effects together.

$$\text{Damping torque,} \quad T_D = D \frac{d\theta}{dt} \quad \dots(7.9)$$

where D = damping constant ; Nm/rad s⁻¹.

(iv) **Control Constant.** A controlling torque is produced due to elasticity of the system which tries to restore the moving system back to its original position.

Controlling torque $T_c = K\theta$, where K = control constant, N-m/rad.

7.6. Equation of Motion. There are four torques acting on the moving system. Deflecting torque T_d tries to accelerate the system while inertia torque T_i , damping torque T_D and the control torque T_c try to retard the system (See Fig. 7.3).

Therefore, for any deflection θ at any instant t ,

$$T_i + T_D + T_c = T_d \quad \text{or} \quad J \frac{d^2\theta}{dt^2} + D \frac{d\theta}{dt} + K\theta = G\theta \quad \dots(7.10)$$

We have now a linear, second degree differential equation whose solution is the sum of a "complementary function" representing a transient condition and a "particular integral" representing the steady state condition.

Complementary Function. The auxiliary equation is $Jm^2 + Dm + K = 0$.

The roots of this equation are :

$$m_1 = \frac{-D + \sqrt{D^2 - 4KJ}}{2J} \quad \text{and} \quad m_2 = \frac{-D - \sqrt{D^2 - 4KJ}}{2J}$$

Thus $\theta = Ae^{m_1 t} + Be^{m_2 t}$... (7.11)

where A and B are constants.

Particular Integral. We pass a steady current i through the galvanometer.

Under steady state conditions $\frac{d^2\theta}{dt^2} = 0$, $\frac{d\theta}{dt} = 0$, and $\theta = \theta_F$

Putting the above conditions in Eqn. 7.10, the final steady state deflection is :

$$\theta_F = \frac{Gi}{K} \quad \dots(7.12)$$

Thus, the complete solution of differential equation is $\theta = A e^{m_1 t} + B e^{m_2 t} + \theta_F$... (7.13)

Now θ_F is the final steady deflection and the term $(Ae^{m_1 t} + Be^{m_2 t})$ represents a motion which may or may not be oscillatory. We can tell the type of behaviour from the form of the roots m_1 and m_2 . There are three possible cases.

Case I $D^2 < 4KJ$

For this case, the two roots m_1 and m_2 are imaginary. Thus under these conditions the motion is oscillatory. The galvanometer oscillates about its final steady position with decreasing amplitude before finally settling at its final steady position. The galvanometer is underdamped in this case.

Case II $D^2 = 4KJ$

In this case both the roots are real and equal. The galvanometer under these conditions is called critically damped. The motion in this case is non-oscillatory and the final steady deflection is reached in shortest time without any overshoot.

Case III $D^2 > 4KJ$

In this case both the roots are real. The galvanometer is called overdamped under these conditions. The motion is non-oscillatory but the galvanometer reaches its final steady position in a sluggish manner.

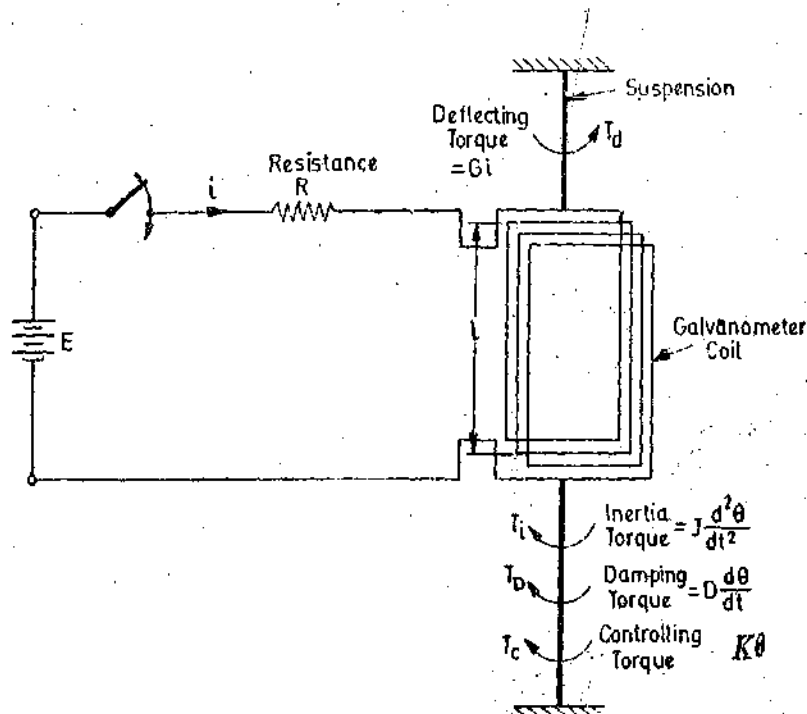

Fig. 7.3. Torques acting on galvanometer moving system.

7.7. Underdamped Motion of a Galvanometer. The motion of a galvanometer is underdamped when

$$D^2 < 4KJ$$

Under these conditions both the roots m_1 and m_2 are imaginary and may be written as :

$$m_1 = \frac{-D + \sqrt{D^2 - 4KJ}}{2J} = \frac{-D + \sqrt{(-1)^2 \times 4KJ - D^2}}{2J}$$

$$= -\frac{D}{2J} + j \frac{\sqrt{4KJ - D^2}}{2J} = -\alpha + j\omega \quad \text{and} \quad m_2 = -\frac{D}{2J} - j \frac{\sqrt{4KJ - D^2}}{2J} = -\alpha - j\omega.$$

Putting the above values in Eqn. 7'13, we get :

$$\theta = A e^{(-\alpha + j\omega)t} + B e^{(-\alpha - j\omega)t} + \theta_r = e^{-\alpha t} [A e^{j\omega t} + B e^{-j\omega t}] + \theta_r.$$

Since $e^{\pm j\omega t}$ is complex and θ is real as it represents a physical quantity, it automatically follows that A and B must be complex.

$$\text{Let} \quad A = a + jb \quad \text{and} \quad B = c + jd$$

$$\therefore \theta = e^{-\alpha t} [(a + jb) e^{j\omega t} + (c + jd) e^{-j\omega t}] + \theta_r$$

$$= e^{-\alpha t} [(a + jb) (\cos \omega t + j \sin \omega t) + (c + jd) (\cos \omega t - j \sin \omega t)] + \theta_r$$

$$= e^{-\alpha t} [(a + c) \cos \omega t - (b + d) \sin \omega t + j(b + d) \cos \omega t + j(a - c) \sin \omega t] + \theta_r \quad \dots(7'14)$$

Since θ is real and therefore the imaginary term of Eqn. 7'14 must be equal to zero for all values of t .

$$\text{Hence, for all values of } t : (b + d) \cos \omega t + (a - c) \sin \omega t = 0$$

$$\text{At } \omega t = 0, \quad b + d = 0 \quad \text{or} \quad b = -d.$$

$$\text{At } \omega t = \pi/2, \quad a - c = 0 \quad \text{or} \quad a = c.$$

$$\therefore A = a + jb \quad \text{and} \quad B = a - jb.$$

Thus we conclude that A and B are complex conjugate pair.

$$\text{We can therefore, write Eqn. 7'14 as } \theta = 2 e^{-\alpha t} [a \cos \omega t + d \sin \omega t] + \theta_r \quad \dots(7'15)$$

$$\text{Let} \quad a = \frac{F}{2} \sin \phi \quad \text{and} \quad d = \frac{F}{2} \cos \phi.$$

$$\therefore F = 2 \sqrt{(a^2 + d^2)} \quad \text{and} \quad \phi = \tan^{-1} \frac{a}{d}.$$

$$\text{Hence we can write } \theta = F e^{-\alpha t} [\sin \phi \cos \omega t + \cos \phi \sin \omega t] + \theta_r$$

$$\theta = F e^{-\alpha t} \sin (\omega t + \phi) + \theta_r \quad \dots(7'16)$$

$$\theta = F e^{\frac{-D}{2J} t} [\sin (\omega t + \phi)] + \theta_r \quad \dots(7'17)$$

$$\text{where} \quad \omega_d = \text{angular frequency of damped oscillations} = \frac{\sqrt{4KJ - D^2}}{2J} \text{ rad/s} \quad \dots(7'18)$$

$$\text{Let us evaluate } \theta_r \text{ and } \phi. \quad \text{At } t = 0, \quad \theta = 0.$$

$$\text{Putting this condition in Eqn. 7'17, we have } 0 = F \sin \phi + \theta_r$$

$$\text{or} \quad \sin \phi = \frac{-\theta_r}{F} \quad \dots(i)$$

Since θ_r and ϕ are positive quantities, F is a negative quantity. Differentiating Eqn. 7'17, we have :

$$\frac{d\theta}{dt} = \frac{-D}{2J} F e^{\frac{-D}{2J}t} \left[\sin(\omega_d t + \phi) \right] + F e^{\frac{-D}{2J}t} \left[\cos(\omega_d t + \phi) \right] \omega_d$$

At $t=0$, $\frac{d\theta}{dt} = 0$.

Substituting this in the above relationship $0 = \frac{-D}{2J} F \sin \phi + F \omega_d \cos \phi$... (i)

$$\therefore \tan \phi = \omega_d \cdot \frac{2J}{D} \quad \dots(7.19)$$

$$= \frac{\sqrt{4KJ - D^2}}{2J} \cdot \frac{2J}{D} = \frac{\sqrt{4KJ - D^2}}{D} \quad \dots(7.20)$$

Substituting the value of $\sin \phi$ in (i), we have

$$0 = \left(\frac{-D}{2J} F \right) \times \left(-\frac{\theta_F}{F} \right) + F \omega_d \cos \phi \quad \text{or} \quad \cos \phi = -\frac{D}{2J\omega_d} \cdot \frac{\theta_F}{F} \quad \dots(7.21)$$

From (i) and (7.21), we get $\left(-\frac{\theta_F}{F} \right)^2 + \left(-\frac{D}{2J\omega_d} \cdot \frac{\theta_F}{F} \right)^2 = 1$

or $F = -\theta_F \left[\frac{4J^2\omega_d^2 + D^2}{4J^2\omega_d^2} \right]^{\frac{1}{2}} \quad \dots(7.22)$

Now $\omega_d = \frac{\sqrt{4KJ - D^2}}{2J} \therefore F = -\theta_F \frac{2\sqrt{KJ}}{\sqrt{4KJ - D^2}} \quad \dots(7.23)$

Substituting the above values of F and ϕ in Eqn. 7.17,

$$\theta = \theta_F \left[1 - \frac{2\sqrt{KJ}}{\sqrt{4KJ - D^2}} e^{\frac{-D}{2J}t} \sin \left(\omega_d t + \tan^{-1} \frac{2J\omega_d}{D} \right) \right] \quad \dots(7.24)$$

$$= \theta_F \left[1 - \frac{2\sqrt{KJ}}{\sqrt{4KJ - D^2}} e^{\frac{-D}{2J}t} \sin \left(\frac{\sqrt{4KJ - D^2}}{2J} t + \tan^{-1} \frac{\sqrt{4KJ - D^2}}{D} \right) \right] \quad \dots(7.25)$$

When a current is suddenly passed through the coil of an underdamped galvanometer, the moving system will start from its zero current position and then oscillate about its final steady state position θ_F . This oscillation would be an attenuated sinusoidal motion. The angular frequency of the sinusoidal component of this motion is ω_d . The frequency of this sinusoidal component (called frequency of damped oscillations) is

$$f_d = \frac{\omega_d}{2\pi} = \frac{1}{2\pi} \cdot \frac{\sqrt{4KJ - D^2}}{2J} \quad \dots(7.26)$$

and the time period is : $T_d = \frac{1}{f_d} = \frac{2\pi}{\omega_d} = 2\pi \cdot \frac{2J}{\sqrt{4KJ - D^2}} \quad \dots(7.27)$

7.8. Undamped Motion of a Galvanometer. The undamped motion of a galvanometer is obtained when there are no damping forces i.e. when $D=0$. Such a case is not possible under practical working conditions, but the properties of the undamped galvanometer are used in expressing its motion under actual operating conditions.

From Eqns. 7.18 and 7.21 for $D=0$ we get : angular frequency $\omega_n = \sqrt{\frac{K}{J}}$... (7.26)

and $F = -\theta_r$... (7.27)

The frequency of undamped (called natural or free) oscillation is :

$$f_n = \frac{\omega_n}{2\pi} = \frac{1}{2\pi} \sqrt{\frac{K}{J}} \quad \dots (7.28)$$

and the free period of oscillations is $T_0 = \frac{1}{f_n} = 2\pi \sqrt{\frac{J}{K}}$... (7.29)

and $\phi_0 = \tan^{-1} \infty = 90^\circ$ (See Eqn. 7.20)

Substituting these values in Eqn. 7.17, we have :

$$\theta = -\theta_r [\sin(\omega_n t + 90^\circ)] + \theta_r = \theta_r (1 - \cos \omega_n t) \quad \dots (7.30)$$

Thus the motion of the undamped galvanometer is an oscillation around θ_r with a constant amplitude θ_r and a frequency f_n .

7.9. Critically Damped Motion of a Galvanometer. The critical damped motion of a galvanometer is obtained when

$$D^2 = 4KJ$$

Under this condition the roots m_1 and m_2 of the auxiliary equation are equal.

$$m_1 = m_2 = -D/2J$$

The solution in this case is $\theta = \theta_r + e^{-\frac{D}{2J}t} [A + Bt]$... (7.31)

where A and B are constants. The values of A and B can be found as under :

Differentiating Eqn. 7.31, we have,

$$\frac{d\theta}{dt} = \left\{ -\frac{D}{2J} \cdot e^{-\frac{D}{2J}t} [A + Bt] + B e^{-\frac{D}{2J}t} \right\} = e^{-\frac{D}{2J}t} \left[-\frac{D}{2J} (A + Bt) + B \right] \quad \dots (7.32)$$

At $t=0$, we have $\theta=0$ and $d\theta/dt=0$

Putting these conditions in Eqns. 7.31 and 7.32

$$0 = \theta_r + A, \quad 0 = -\frac{D}{2J} A + B \quad \therefore A = -\theta_r \text{ and } B = -\frac{D}{2J} \theta_r.$$

Hence the solution is $\theta = \theta_r \left[1 - e^{-\frac{D}{2J}t} \left(1 + \frac{D}{2J}t \right) \right]$... (7.33)

Now for critical damping $D = D_c = 2\sqrt{KJ}$... (7.34)

where D_c = damping constant for critical damping.

Under critical damping conditions

$$\frac{D}{2J} = \frac{2\sqrt{KJ}}{2J} = \sqrt{\frac{K}{J}} = \omega_n \quad \dots (7.35)$$

\therefore For a critically damped galvanometer : $\theta = \theta_r \left[1 - e^{-\omega_n t} (1 + \omega_n t) \right]$... (7.36)

For critical damping the pointer quickly moves to its final steady position without any oscillations. The curve for critical damping is shown in Fig. 6.13. It is clear from Fig. 6.13 that the time taken

by the coil to reach its final steady position is smaller in the case of critical damping than that for over-damping.

Response. If we examine Fig. 6'13, we find that an underdamped galvanometer causes a great waste of time as the coil settles to its final steady position after oscillating about it. An over-damped galvanometer represents a very sluggish behaviour and loss of time. A critically damped galvanometer represents an arrangement that takes the coil to its final steady position in the minimum time that is possible without overshooting. The best operating conditions are attained with a galvanometer that is either critically damped, or slightly under-damped which may even give a faster response.

If the damping is slightly less than the critical value the galvanometer swings a little beyond final position on the first swing, but comes to rest soon.

7'10. Operational Constants. We have derived the galvanometer equations in terms of the intrinsic constants, J , D and K . These are basic physical constants and are important for a designer. But unfortunately, to a user, these are not known and also their evaluation is difficult. The user is interested in the so called "operational constants". These are the sensitivity, the critical damping resistance, and the time period.

7'11. Relative Damping. The damping of a galvanometer is expressed most conveniently with critical damping case.

The damping ratio is defined as the ratio of the actual damping constant to the damping constant required for critical damping.

$$\therefore \text{Damping ratio } \zeta = D/D_c \quad \dots(7'37)$$

$$\text{But } D_c = 2\sqrt{KJ} \quad \therefore \zeta = D/2\sqrt{KJ} \quad \dots(7'38)$$

$$\text{Now } \frac{D}{2J} = \frac{D}{2\sqrt{KJ}} \cdot \sqrt{\frac{K}{J}} = \zeta \omega_n \quad \dots(7'39)$$

$$\begin{aligned} \tan \phi &= \sqrt{\frac{4KJ - D^2}{D^2}} = \sqrt{\frac{4KJ}{D^2} - 1} = \sqrt{\left(\frac{2\sqrt{KJ}}{D}\right)^2 - 1} = \sqrt{\frac{1}{\zeta^2} - 1} \\ &= \sqrt{\frac{1 - \zeta^2}{\zeta}} \quad \dots(7'40) \end{aligned}$$

$$\sin \phi = \sqrt{1 - \zeta^2} \quad \dots(7'41)$$

$$\cos \phi = \zeta \quad \dots(7'42)$$

$$\text{We have: } \frac{2\sqrt{KJ}}{\sqrt{4KJ - D^2}} = \sqrt{\frac{K}{J}} \cdot \frac{2J}{\sqrt{4KJ - D^2}} = \frac{\omega_n}{\omega_d} \quad \dots(7'43)$$

$$\text{Now } \frac{\omega_n}{\omega_d} = \frac{2\sqrt{KJ}}{\sqrt{4KJ - D^2}} = \frac{1}{\sqrt{1 - D^2/4KJ}} \quad \text{But } D_c = 2\sqrt{KJ}$$

$$\therefore \frac{\omega_n}{\omega_d} = \frac{1}{\sqrt{1 - D^2/D_c^2}} = \frac{1}{\sqrt{1 - \zeta^2}} \quad \dots(7'44)$$

$$\text{From Eqn. 7'44, we get } \omega_d = \omega_n \sqrt{1 - \zeta^2} \quad \dots(7'45)$$

Substituting the values of different quantities listed above, we can write Eqn. 7'23 as :

$$\theta = \theta_r \left[1 - \frac{\omega_n}{\omega_d} e^{-\zeta \omega_n t} \sin(\omega_d t + \phi) \right] \quad \dots(7'46)$$

$$= \theta_r \left[1 - \frac{1}{\sqrt{1 - \zeta^2}} e^{-\zeta \omega_n t} \sin \left(\omega_n t + \tan^{-1} \frac{\sqrt{1 - \zeta^2}}{\zeta} \right) \right] \quad \dots(7'47)$$

$$= \theta_r \left[1 - \frac{1}{\sqrt{1-\zeta^2}} e^{-\zeta\omega_n t} \sin \left(\omega_d t + \sin^{-1} \sqrt{1-\zeta^2} \right) \right] \quad \dots(7.48)$$

$$\text{Now } \frac{T_o}{T_d} = \frac{f_d}{f_n} = \frac{\omega_d}{\omega_n} \quad \text{But } \frac{\omega_d}{\omega_n} = \sqrt{1-\zeta^2} \quad \therefore \frac{T_o}{T_d} = \sqrt{1-\zeta^2} \quad \dots(7.49)$$

$$\text{Also, } \zeta\omega_n = \frac{2\pi\zeta}{T_o}$$

Substituting the above values in Eqn. 7.47, we get :

$$\theta = \theta_r \left[1 - \frac{1}{\sqrt{1-\zeta^2}} e^{-\frac{2\pi\zeta t}{T_o}} \sin \left(\frac{2\pi}{T_o} \sqrt{1-\zeta^2} t + \sin^{-1} \sqrt{1-\zeta^2} \right) \right] \quad \dots(7.50)$$

$$= \theta_r \left[1 - \frac{T_d}{T_o} e^{-\frac{2\pi\zeta t}{T_o}} \sin \left(\frac{2\pi t}{T_d} + \sin^{-1} \frac{T_o}{T_d} \right) \right] \quad \dots(7.51)$$

It may be noted here that this equation describes the galvanometer motion in terms of operational constants, i.e., relative damping, free period, and sensitivity (the last being implied in θ_r).

7.12. Logarithmic Decrement. The time required for the deflection to reach a maximum value may be obtained by putting $d\theta/dt=0$. Differentiating Eqn. 7.47, we get

$$\frac{d\theta}{dt} = \frac{\zeta\omega_n}{\sqrt{1-\zeta^2}} e^{-\zeta\omega_n t} \sin \left(\omega_d t + \tan^{-1} \frac{\sqrt{1-\zeta^2}}{\zeta} \right)$$

$$- \omega_d e^{\zeta\omega_n t} \cos \left(\omega_d t + \tan^{-1} \frac{\sqrt{1-\zeta^2}}{\zeta} \right) = 0$$

$$\text{or } \tan \left(\omega_d t + \tan^{-1} \frac{\sqrt{1-\zeta^2}}{\zeta} \right) = \frac{\omega_d}{\zeta\omega_n} = \frac{\sqrt{1-\zeta^2}}{\zeta}$$

The above can be true only if $\omega_d t = N\pi$ where N is an integer. ... (7.52)

If N is an even integer, we get a minimum value of deflection since the initial value $t=0$ represents a minimum. When N is an odd integer t corresponds to a maximum value.

The first maximum value of deflection occurs at t_1 for $N=1$.

$$\therefore \text{ We have } \omega_d t_1 = \pi \quad \text{or } t_1 = \frac{\pi}{\omega_d} = \frac{\pi}{\omega_n \sqrt{1-\zeta^2}}$$

Substituting this value in Eqn. 7.48, the first maximum deflection is :

$$\begin{aligned} \theta_1 &= \theta_r \left[1 - \frac{1}{\sqrt{1-\zeta^2}} e^{-\pi\zeta/\sqrt{1-\zeta^2}} \sin \left(\pi + \sin^{-1} \sqrt{1-\zeta^2} \right) \right] \\ &= \theta_r [1 + e^{-\pi\zeta/\sqrt{1-\zeta^2}}] \end{aligned} \quad \dots(7.53)$$

$$\text{or } \theta_1 - \theta_r = \theta_r e^{-\pi\zeta/\sqrt{1-\zeta^2}} \quad \dots(7.54)$$

Eqn. 7.54 gives the first over shoot.

Now, the first minimum deflection occurs at $t=t_2$ where $t_2=2\pi/\omega_d$.

Substituting this value of t in Eqn. 7.48, we get,

$$\theta_2 = \theta_F [1 - e^{-2\pi\zeta/\sqrt{1-\zeta^2}}] \quad \dots(7.55)$$

The first undershoot is given by : $\theta_F - \theta_2 = e^{-2\pi\zeta/\sqrt{1-\zeta^2}}$... (7.56)

Taking the ratio of successive extreme deviations from the final steady deflection we have :

$$\frac{\theta_F - \theta_2}{\theta_1 - \theta_F} = \frac{e^{-2\pi\zeta/\sqrt{1-\zeta^2}}}{e^{-\pi\zeta/\sqrt{1-\zeta^2}}} = e^{-\pi\zeta/\sqrt{1-\zeta^2}}$$

From which we get $-\log_e \left(\frac{\theta_F - \theta_2}{\theta_1 - \theta_F} \right) = \frac{\pi\zeta}{\sqrt{1-\zeta^2}}$

Logarithmic Decrement is defined as the Napierian logarithm of the ratio of successive swings.

Logarithmic decrement $\lambda = \log_e \left(\frac{\theta_1 - \theta_F}{\theta_F - \theta_2} \right) = -\log_e \left(\frac{\theta_F - \theta_2}{\theta_1 - \theta_F} \right) = \frac{\pi\zeta}{\sqrt{1-\zeta^2}}$... (7.57)

But $\frac{T_o}{T_d} = \sqrt{1-\zeta^2}$ (See Eqn. 7.49)

$\therefore \lambda = \pi\zeta \frac{T_d}{T_o}$... (7.58)

Eqn. 7.51 may be expressed as

$$\theta = \theta_F \left[1 - \frac{T_d}{T_o} e^{-2\lambda t/T_d} \left\{ \sin \left(\frac{2\pi t}{T_d} + \sin^{-1} \frac{\pi\zeta}{\lambda} \right) \right\} \right] \quad \dots(7.59)$$

$$= \theta_F \left[1 - \frac{\omega_n}{\omega_d} e^{-\omega_d \lambda t/\pi} \sin \left(\omega_d t + \sin^{-1} \frac{\pi\zeta}{\lambda} \right) \right] \quad \dots(7.60)$$

7.13. **Overshoot.** Fig. 7.4 shows an expanded scale the upper portions of curves computed from Eqn 7.51 for $\zeta=0.6$ and 0.8 . In order to have comparison the critical curve $\zeta=1$ is also drawn.

The curve with $\zeta=0.8$ has a very small overshoot but the curve with $\zeta=0.6$ has an overshoot of about 10 per cent. Actually we are interested in the time taken by the galvanometer to settle to its final position but this "time of deflection" is used in a loose way as in fact the deflection only approaches the final value asymptotically and never reaches it. If we assume that we are interested in reading the galvanometer to a precision Δ , we require only that the deflection arrives at and remains within a band $\theta_F \pm \Delta\theta$. A band of ± 1 per cent is sometimes indicated. However, ± 2 per cent is used in Fig. 7.4 in order to get a clear idea. The 0.8 curve enters the band at $t=0.6 T_o$ and stays within it while the critical curve enters the band at $t=0.94 T_o$.

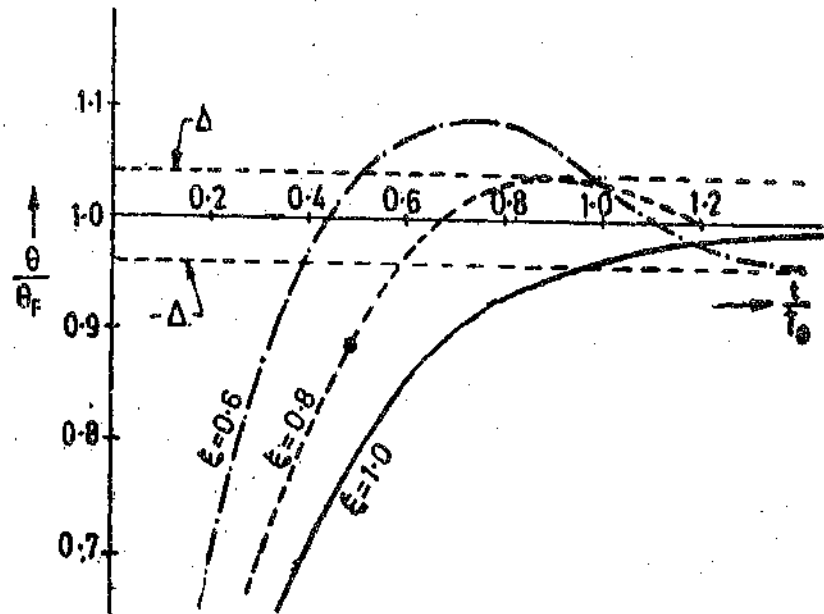

Fig. 7.4

The $\zeta=0.6$ curve cuts across both limits quite early but finally enters the band at $t=0.94 T_o$. If ± 1 per cent band had been used, the three curves would have nearly the same entry points. Thus it is clear that the time for deflection is small for any value of damping with $\zeta=0.6$ to 1.0 , and, therefore, any damping arrangement (between $\zeta=0.6$ to 1.0) could be selected by the operator. Some underdamping, with ζ from 0.6 to 0.8 , actually has advantage over the critical condition as a small overshoot indicates to the operator that the coil is moving freely without touching the poles. Underdamping is done for all indicating instruments

and the small overshoot is considered to be an advantage as it is an assurance of free movement of the metering element and good conditions of the pivots and jewels.

7.14. Overdamped Motion of Galvanometer. The overdamped motion of a galvanometer is non-oscillatory and is obtained when

$$D^2 > 4KJ$$

Under these conditions both the roots m_1 and m_2 are real.

The solution under this case is : $\theta = A e^{m_1 t} + B e^{m_2 t} + \theta_r$

The complete solution is :

$$\theta = \theta_r \left[1 + \frac{\zeta + \sqrt{\zeta^2 - 1}}{2\sqrt{\zeta^2 - 1}} e^{-\omega_n (\zeta - \sqrt{\zeta^2 - 1}) t} - \frac{\zeta - \sqrt{\zeta^2 - 1}}{2\sqrt{\zeta^2 - 1}} e^{-\omega_n (\zeta + \sqrt{\zeta^2 - 1}) t} \right] \dots (7.61)$$

The above equation represents a decaying motion without oscillations or overshoot but this motion is usually slow and is not desirable in indicating instruments.

7.15. Non-dimensional Curves of a Galvanometer Motion. It is often advantageous to plot curves in terms of non-dimensional functions, as these curves do not represent a particular data but are general and represent a function in which the constants may be inserted to obtain a particular solution.

Fig. 7.5 shows the galvanometer motion plotted against time for various values of relative damping. Time t is stated in terms of the free period T_0 of the galvanometer, and the deflection θ in terms of the final deflection θ_r .

An inspection of these curves shows that :

(i) The actual time period, (i.e., period of damped oscillations) increases slowly for damped vibrations and then more rapidly as critical damping is approached.

(ii) The oscillations persist for a considerable time for small values of damping but this time quickly becomes negligible as damping approaches critical value ; and

(iii) For damping greater than critical, the motion becomes sluggish. Thus it is clear that for overdamping ($\zeta > 1$) the time taken to reach the final steady deflection is unnecessarily long.

7.16. Damping. Damping means dissipation of energy of rotation. This dissipation of energy is due partly to mechanical effects, and usually to a greater extent, due to electromagnetic effects from the coil circuit.

(a) **Mechanical Damping.** Mechanical damping is mostly due to friction produced owing to motion of coil in the air surrounding it. A small dissipation of energy is associated with flexing of suspension (elastic hysteresis).

Damping torque due to mechanical effects is $T_m = D_m \cdot \frac{d\theta}{dt}$

where D_m = damping constant due to mechanical damping.

(b) **Electromagnetic Damping.** Electromagnetic damping is produced by the induced effects

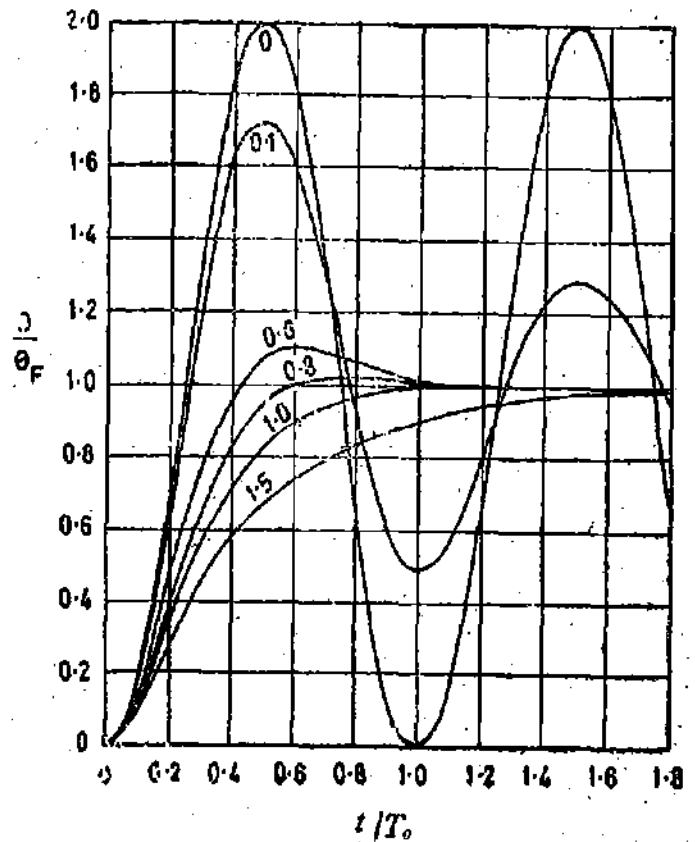

Fig. 7.5. Non-dimensional curves of a galvanometer.

when the coil moves in the magnetic field and a closed path is provided for the currents to flow. The electromagnetic damping is because of :

- (i) eddy currents produced in the metal former ;
- (ii) current circulated in the coil circuit by emf generated in the coil when it rotates.

The damping may be classified as :

Open Circuit Damping. The damping effects produced by friction, elastic hysteresis, and eddy currents in metal former are always present whether the galvanometer circuit is closed or not and, therefore, the damping produced by these effects is called open circuit damping.

Damping due to Coil Circuit Resistance. The damping effect produced by current flowing in the coil is only present when circuit of the coil is closed.

Expressions

Let R = resistance of galvanometer circuit when closed = $R_g + R_e$

R_g = resistance of galvanometer coil,

and R_e = external resistance required for damping.

The voltage induced in the coil by its motion

$$e = 2N \times Blv = 2N \times Bl \cdot \frac{d}{2} \omega = NBl d \cdot \frac{d\theta}{dt}$$

The current flowing in the circuit due to emf e is : $i = \frac{e}{R} = \frac{NBl d}{R} \cdot \frac{d\theta}{dt}$

∴ Torque produced owing to current flowing in the coil,

T_{coil} = conductors \times force on each conductor \times distance

$$= N \times Bil \times d = NBl d \times i = NBl d \times \frac{NBl d}{R} \cdot \frac{d\theta}{dt} = \frac{(NBl d)^2}{R} \left(\frac{d\theta}{dt} \right)$$

$$= \frac{G^2}{R} \cdot \left(\frac{d\theta}{dt} \right)$$

...(7'62)

as $G = NBl d$

∴ Damping constant due to resistance of circuit $D_{circuit} = G^2/R$

...(7'63)

Hence $T_{coil} = D_{circuit} \cdot \frac{d\theta}{dt}$

...(7'64)

Let us consider the damping effect of former. Let R_f be the resistance of the former.

∴ Proceeding as earlier, the damping torque produced by the former is :

$$T_f = \frac{(Bl d)^2}{R_f} \cdot \left(\frac{d\theta}{dt} \right) \text{ (As } N=1 \text{ for the former)}$$

or $T_f = \frac{G^2}{N^2 R_f} \left(\frac{d\theta}{dt} \right) = D_{former} \frac{d\theta}{dt}$

...(7'65)

Damping constant due to resistance of former = $D_{former} = \frac{G^2}{N^2 R_f}$

...(7'66)

∴ Total electromagnetic damping torque $T_e = \left(\frac{G^2}{R} + \frac{G^2}{N^2 R_f} \right) \cdot \frac{d\theta}{dt} = D_e \frac{d\theta}{dt}$

...(7'67)

where D_e = damping constant due to electromagnetic effects = $\frac{G^2}{R} + \frac{G^2}{N^2 R_f}$

...(7'68)

Total Damping. Total damping effect is made up of two components i.e., damping due to mechanical effects and damping due to electromagnetic effects.

$$\text{Total damping torque } T_D = T_m + T_e = D_m \frac{d\theta}{dt} + D_e \frac{d\theta}{dt} = (D_m + D_e) \frac{d\theta}{dt} \quad \dots(7.69)$$

$$= D_c \cdot \frac{d\theta}{dt} \quad \dots(7.70)$$

where D = damping constant due to combined effects of mechanical and electromagnetic damping = $D_m + D_e$.

Critical Resistance. The mechanical damping effects are very small as compared with electromagnetic effects, and therefore, $D_m = 0$

$$\text{So that we have, } D = D_e = \frac{G^2}{R} + \frac{G^2}{N^2 R_f}$$

The damping due to metal former is usually small and hence we can put $\frac{G^2}{N^2 R_f} = 0$

$$\therefore D = \frac{G^2}{R} \quad \dots(7.71)$$

For critical damping $D = D_c = 2\sqrt{KJ}$ (See Eqn. 7.34)

$$\therefore \text{For critical damping } \frac{G^2}{R} = 2\sqrt{KJ} \quad \dots(7.72)$$

Hence for critical damping the total resistance of the galvanometer circuit should be

$$R = \frac{G^2}{2\sqrt{KJ}} \quad \dots(7.73)$$

Thus for a particular galvanometer for which G , J and K are constant, critical damping conditions can be obtained by properly adjusting the value of the external resistance connected in the galvanometer circuit.

$$\text{External series resistance required for critical damping } R_e = R - R_o = \frac{G^2}{2\sqrt{KJ}} - R_o \quad \dots(7.74)$$

This external resistance required for critical damping is called *CDRX* or *ECDR*, critical damping resistance external.

7.17. Sensitivity. The sensitivity of a galvanometer may be defined in several ways i.e., current, voltage and Meghm sensitivities.

1. Current Sensitivity. The current sensitivity of a galvanometer is defined as the deflection produced by unit current.

$$\therefore \text{Current sensitivity } S_i = \frac{\theta_r}{i}, \quad \text{but } \theta_r = \frac{Gi}{K}$$

$$\therefore S_i = \frac{Gi}{K} \cdot \frac{1}{i} = \frac{G}{K} \text{ rad/A} \quad \dots(7.75)$$

In practice the currents involved are small and the deflection is measured in terms of divisions or distance moved by spot on a scale. Thus the definition of sensitivity as given by Eqn. 7.75 is not relevant to practical measurement work. So while doing practical work, the sensitivity is expressed in terms of scale divisions per microampere or mm/ μ A.

$$\text{Current sensitivity } S_i = \frac{d}{i \times 10^6} \text{ scale divisions}/\mu\text{A} \quad \dots(7.76)$$

where i = current in ampere, and d = deflection in scale divisions.

The scale has usually 1 mm divisions and is placed 1 m away from the galvanometer. The current sensitivity for such a galvanometer is

$$S_i = \frac{d}{i \times 10^6} \text{ mm}/\mu\text{A} \quad \dots(7.77)$$

But $\frac{i}{d} = \frac{K}{2000 G}$ (see Eqn. 7.6)

$$\therefore S_i = \frac{2000 G}{K \times 10^6} = \frac{G}{500 K} \text{ mm}/\mu\text{A} \quad \dots(7.78)$$

2. Voltage Sensitivity. The voltage sensitivity is the deflection in scale divisions per unit voltage impressed on the galvanometer.

Voltage sensitivity S_v = scale divisions per unit voltage

$$= \frac{d}{i \times R_g \times 10^6} \text{ scale division}/\mu\text{V} \quad \dots(7.79)$$

For a galvanometer with scale 1 m away and one scale division = 1 mm,

$$S_v = \frac{2000 G}{K R_g \times 10^6} = \frac{G}{500 K R_g} \text{ mm}/\mu\text{V} \quad \dots(7.80)$$

In America it is a practice to include *CDRX* in the galvanometer circuit for the purpose of defining voltage sensitivity. Accordingly the definition of voltage sensitivity is :

S_v = scale divisions per unit voltage with galvanometer and *CDRX* in series.

For a galvanometer with scale 1 m away and 1 scale division = 1 mm,

$$S_v = \frac{G}{500 K(R_g + \text{CDRX})} \text{ mm}/\mu\text{V} \quad \dots(7.81)$$

3. Megohm Sensitivity. The megohm sensitivity is the resistance of the circuit (in $M\Omega$) so that the deflection will be 1 scale division with 1 volt impressed to the circuit. As the coil resistance is negligible in comparison, the megohm sensitivity represents the resistance that must be put in series with the galvanometer so that 1 volt gives a deflection of 1 scale division. In fact megohm sensitivity is the current sensitivity (expressed in microampere per scale division).

Megohm sensitivity

S_0 = resistance in megohm to give a deflection of one scale division with 1 volt

$$= \frac{d}{i \times 10^6} \text{ M}\Omega/\text{scale division} \quad \dots(7.82)$$

For a galvanometer with scale 1 m away and 1 scale division = 1 mm,

$$S_0 = \frac{G}{500 K} \text{ M}\Omega/\text{mm} \quad \dots(7.83)$$

Comments. A sensitive galvanometer is one which produces a large deflection for a small current. We have current sensitivity,

$$S_i = \frac{d \times 10^6}{i} = \frac{G}{500 K} \text{ mm}/\mu\text{A}.$$

Thus the value of S_i should be large in order that a galvanometer be sensitive. Hence for a sensitive galvanometer the displacement constant G should be large and control constant S should be small.

Now, displacement constant $G = NBA$. Therefore, the sensitivity can be increased by increasing the number of turns, using a high flux density and by increasing the dimensions of the coil. For a given coil area $A (=ld)$ and a constant value of flux density B , displacement constant G can be increased by increasing the number of turns. If the winding area is fixed, a large number of turns can only be wound if we use thin wire. Thus we can increase the sensitivity of a galvanometer by winding its coil with large number of turns of thin fine wire. Hence for a sensitive galvanometer the value of resistance of coil R_c is large.

We can increase the sensitivity by making the control constant K small. Thus a suspension of small stiffness leads to increased sensitivity.

7.18. Galvanometer Types. D.C. galvanometers are made in three general types :

(i) *Portable Point Type*. They are small instruments, similar in construction to other types of portable instruments. They may be pivoted or may have taut suspension.

(ii) *Laboratory Reflecting Type*. They are highly sensitive instruments.

(iii) *Box Type*. They have taut suspensions and do not require exact levelling. The box includes the complete optical system and, therefore, it is not necessary to make separate mounting for galvanometer, lamp and scale etc.

The characteristics of different types of galvanometers are listed in Table 7.1.

TABLE 7.1
Typical Characteristics of Moving Coil Galvanometers

Type of Galvanometer	Sensitivity mm/μA	Period second	Resistance Ω	
			CDRX	Coil
Pointer	0.5	2.5	20	12
	1.0	3	110	25
	4.0	3	1,800	250
Light spot and pointer	5, 0.4	2	100	10
	25, 2.0	2	3,500	1,000
Reflecting lamp and scale	250	5	900	80
	2000	6	10,000	650
	10,000	14	22,000	500
	100,000	40	100,000	800
Box type self contained	200	2.5	400	25
	2,000	3	25,000	550

7.19. Galvanometer Shunts. In the case of preliminary balancing work in bridge and potentiometer measurements, the potential across the galvanometer circuit may be high owing to unbalance. If we are using galvanometer which has sufficient sensitivity for final stages of balancing the large unbalance that probably exists at the start is likely to damage the coil or the suspension.

This is because the potential across the galvanometer circuit (due to unbalance) circulates a large current through the coil which results in large deflection with consequent twisting of suspension. Large current also produces undesirable heating effects. Sometimes even if the above effects are not there, excessive currents send the light spot so far off the scale that the deflection is not readable and the operator does not know what to do to improve the conditions. Thus it is very necessary to use protective device of some sort to protect the sensitive galvanometers from the above damaging effects.

The simplest procedure is to use :

(i) A high resistance in series with the galvanometer to limit the current produced by the available emf. The series resistance underdamps the galvanometer circuit.

(ii) A low resistance is connected across the terminals of the galvanometer thus by-passing most of the current. This reduces the sensitivity of the galvanometer circuit so that the response of the instrument to a given current is reduced. A low resistance shunt will heavily overdamp the instrument so that its motion will be sluggish.

For both series and shunt resistances the time required to attain the final deflection is excessive. As a general rule a combination of a series and a shunt resistance is preferable which will give the desired reduction in sensitivity and at the same time the proper damping characteristics.

720. **Ayrton Universal Shunt.** Fig. 76 shows an arrangement which incorporates combination of series and parallel resistances. It is clear from the diagram that the lower part of the resistance (*i.e.*, *bc* below the sliding contact) is in parallel while the upper part of the resistance (*i.e.*, *ab* above the sliding contact) is in series with the galvanometer. When the sliding contact is near the lower end, a small part of resistance is in parallel with the galvanometer and the major part is in series with the galvanometer. The current divides itself in two parts, the major going through the shunt and only a small part through the galvanometer, thus protecting it and giving a small sensitivity. As the sliding contact is moved up, the shunt resistance increases and the series resistance decreases. This increases the current through the galvanometer and thus the sensitivity is increased. However, there is a loss of sensitivity (as compared with galvanometer alone) with the sliding contact even at the top point. However, this is not a serious limitation if the resistance R_m is very large as compared with galvanometer resistance R_g .

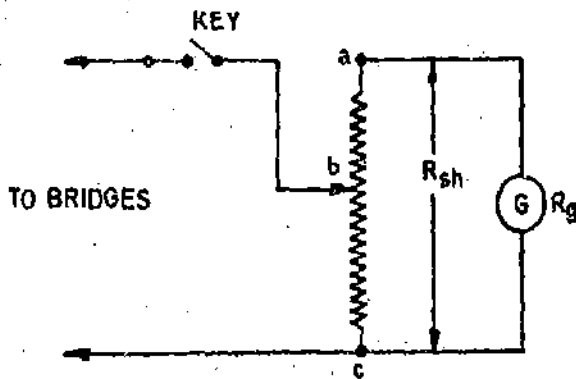

Fig. 76. Galvanometer Shunt.

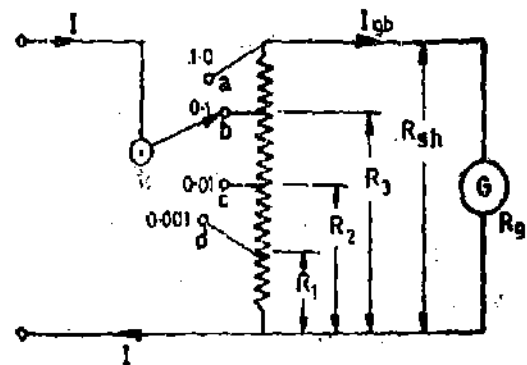

Fig. 77. Ayrton universal shunt.

With key *K* open as in Fig. 76, there is closed circuit through the galvanometer coil and R_m and this provides a damping circuit. Therefore, the value of R_m should be equal to $CDRX$ (a little higher value is satisfactory). As $CDRX$ is usually several times R_g , the loss of sensitivity due to using a shunt of this value is not serious.

Ayrton universal shunt construction is shown in Fig. 77. This arrangement uses a dial type switch. The numbers on the contacts represent the relative values of galvanometer current. The resistance of each section to give the desired current can be calculated as under :

Current through the galvanometer at contact '*a*' or '*1*'

$$I_{ga} = I \frac{R_m}{R_m + R_g}$$

When the contact is at b , the resistance R_3 is in parallel with resistances $(R_{1a} - R_3)$ and R_0 in series.

∴ Current through the galvanometer at contact 'b' or '0.1'

$$I_{ob} = I \frac{R_3}{R_3 + (R_{1a} - R_3 + R_0)} = I \frac{R_3}{R_{1a} + R_0}$$

The current through the galvanometer at contact 'b' should be 0.1 of current at contact 'a'.

We have
$$\frac{I_{ob}}{I_{oa}} = \frac{I \frac{R_3}{R_{1a} + R_0}}{I \frac{R_{1a}}{R_{1a} + R_0}} = \frac{R_3}{R_{1a}} \quad \therefore \frac{R_3}{R_{1a}} = 0.1 \text{ in order that } \frac{I_{ob}}{I_{oa}} = 0.1$$

Similarly, $R_2/R_{1a} = 0.01$ and $R_1/R_{1a} = 0.001$

It should be noted that the relative values of current (through the galvanometer and through the shunt) do not depend upon the value of galvanometer resistance. The shunt thus gives the same relative current values for the various steps for all galvanometers although not the same fraction of the total current. Therefore, it is called a **Universal Shunt**.

Initially we should keep the sliding contacts at the lower end. This diverts most of the current through the shunt and hence decreases the sensitivity of the galvanometer. The sliding contacts can be moved up and sensitivity increased as we approach the balance conditions.

Example 7.1. The scale of a galvanometer is placed at a distance of 0.4 m from the mirror. A deflection of 44 mm is observed. What is the angle through which the coil has turned.

Solution : Suppose d is the deflection, r is the distance between scale and mirror, and θ_r is the angle turned through by the mirror.

$$\begin{aligned} \therefore d &= 2r\theta_r \quad \text{or angle turned through by mirror} \\ &= \frac{d}{2r} = \frac{44 \times 10^{-3}}{2 \times 0.4} = 55 \times 10^{-3} \text{ rad} = 3.15^\circ = 3^\circ 9' \end{aligned}$$

Example 7.2. A wire used as a torsion member in a small galvanometer is 0.1 mm in diameter, arranged as shown in Fig. 7.8. It is made of phosphor bronze for which the modulus of rigidity is 40 GN/m². Calculate the angular torque and maximum allowable torque if the stress is limited to 100 MN/m².

A collimated ray of light is reflected by the galvanometer mirror shown. The radius from the mirror to the circular scale is 200 mm. Calculate the sensitivity of the instrument in m/Nm and the maximum possible scale deflection.

Solution : For a round wire

$$\frac{T}{I_p} = \frac{f_s}{R} = \frac{G\theta}{l}$$

$$I_p = \text{polar moment of inertia} = \frac{\pi}{32} d^4$$

d = diameter of wire ; m,

f_s = shear stress ; N/m²,

R = radius ; m,

G = modulus of rigidity ; N/m²,

l = length of wire ; m,

θ = deflection ; rad.

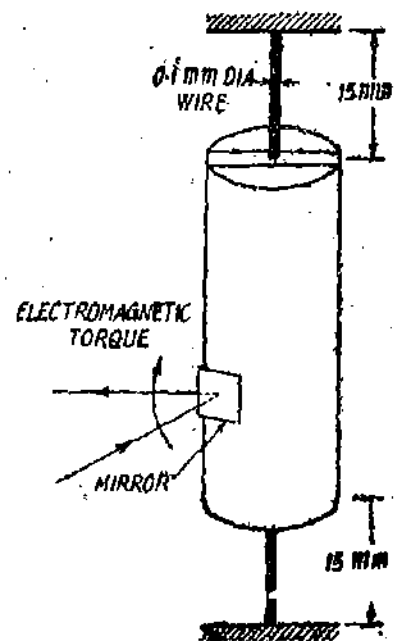

Fig. 7.8. A galvanometer moving system.

Hence, the deflection per unit torque is : $\frac{\theta}{T} = \frac{l}{GI_p}$.

Since there are two wires, one at the top and the other at the bottom, the deflection is half of that for single wire.

$$\therefore \frac{\theta}{T} = \frac{l}{2GI_p} = \frac{l}{2G \times (\pi/32)d^4} = \frac{16l}{\pi Gd^4} = \frac{16 \times (15 \times 10^{-3})}{\pi \times (40 \times 10^9) \times (0.1 \times 10^{-3})^4} = 19 \times 10^3 \text{ rad/Nm.}$$

$$\text{Torsional constant } K = \frac{T}{\theta} = \frac{\pi Gd^4}{16l} = \frac{1}{19 \times 10^3} = 52.6 \times 10^{-9} \text{ Nm/rad.}$$

The maximum stress occurs at the outermost surface :

$$\therefore \text{Maximum torque } T = \frac{f_s I_p}{R} = \frac{f_s \times (\pi/32)d^4}{d/2} = \frac{\pi f_s d^3}{16}$$

Since there are two wires, the maximum allowable torque is :

$$T = \frac{2 \times \pi f_s d^3}{16} = \frac{\pi}{8} f_s d^3 = \frac{\pi}{8} \times (100 \times 10^6) \times (0.1 \times 10^{-3})^3 = 39.3 \times 10^{-6} \text{ Nm.}$$

The scale is kept at a radius of 200 mm, and therefore the sensitivity of the scale is :

$$S = (19 \times 10^3) \times 200 = 3800 \times 10^3 \text{ mm/Nm} = 3800 \text{ m/Nm.}$$

$$\text{The deflection for maximum torque} = 3800 \times 10^3 \times 39.3 \times 10^{-6} = 149.3 \text{ mm.}$$

Example 7.3. The coil of a moving coil galvanometer is wound on a non-magnetic former whose height and width are both 2 cm. It moves in a constant field of 0.12 Wb/m^2 . The moment of Inertia of its moving parts $0.25 \times 10^{-6} \text{ kg-m}^2$, and the control spring constant is $30 \times 10^{-6} \text{ Nm/rad}$. Calculate :

(a) the number of turns that must be wound on the coil to produce a deflection of 150° with a current of 10 mA,

(b) the resistance of the coil to produce critical damping, all damping being assumed as electromagnetic.

$$\text{Solution : Final steady deflection } \theta_F = 150^\circ = \frac{5}{6} \pi \text{ rad.}$$

$$\text{Current } i = 10 \text{ mA} = 10 \times 10^{-3} \text{ A. Control spring constant } K = 30 \times 10^{-6} \text{ Nm/rad.}$$

$$(a) \text{ Final steady deflection } \theta_F = \frac{Gi}{K}$$

$$\therefore \text{Displacement constant } G = \frac{K\theta_F}{i} = \frac{30 \times 10^{-6} \times (5/6)\pi}{10 \times 10^{-3}} = 2.5\pi \times 10^{-3} \text{ Nm/A}$$

$$\text{But displacement constant } G = NBId$$

$$\therefore \text{Number of turns } N = \frac{G}{BID} = \frac{2.5\pi \times 10^{-3}}{0.12 \times 0.02 \times 0.02} = 164$$

Resistance of galvanometer circuit for critical damping (See Eqn. 7.73)

$$R = \frac{G^2}{2\sqrt{KJ}} = \frac{(2.5\pi \times 10^{-3})^2}{2\sqrt{30 \times 10^{-6} \times 0.25 \times 10^{-6}}} = 11.25 \Omega.$$

Example 7.4. The coil of a moving coil galvanometer has 380 turns and is suspended in a uniform magnetic field of 0.1 Wb/m^2 . The control constant is $0.2 \times 10^{-6} \text{ N-m/rad}$. The coil is 20 mm wide and 25 mm high, with a moment of inertia of $0.15 \times 10^{-6} \text{ kg-m}^2$.

If the galvanometer resistance is 200Ω , calculate the value of the resistance which, when connected in the galvanometer terminals, will give critical damping. Assume the damping to be entirely electromagnetic.

Solution : Displacement constant, $G = NB l d = 300 \times 0.1 \times 0.025 \times 0.02 = 15 \times 10^{-3} \text{ N-m/A}$

For critical damping $D = 2\sqrt{KJ} = 2\sqrt{0.2 \times 10^{-6} \times 0.15 \times 10^{-6}} = 0.346 \text{ Nm/rad s}^{-1}$

If the damping is wholly electromagnetic $D = \frac{G^2}{R}$ (See Eqn. 7.71)

\therefore Resistance of galvanometer circuit $R = \frac{G^2}{D} = \frac{(15 \times 10^{-3})^2}{0.346 \times 10^{-6}} = 650 \Omega$.

\therefore External resistance for critical damping $C D R X = R - R_0 = 650 - 200 = 450 \Omega$.

Example 7.5. A galvanometer gives a deflection of 150 mm on a linear scale distant 2.5 m for a steady current of $1 \mu\text{A}$. The period of oscillations is 4 s and the moment of inertia of moving system is $1 \times 10^{-6} \text{ kg m}^2$. Calculate the coil circuit resistance necessary to obtain critical damping, assuming air damping to be negligible.

Solution : Suppose the final steady deflection is θ_F radian. Let r be the distance of scale from the galvanometer and d be the deflection on the linear scale.

$\therefore d = r\theta_F$ or steady deflection $\theta_F = \frac{d}{r} = \frac{150}{2500} = 0.06 \text{ rad}$.

But steady deflection $\theta_F = \frac{GI}{K}$

\therefore Displacement constant $G = \frac{\theta_F K}{I} = \frac{0.06 \times K}{1 \times 10^{-6}} = 60K \times 10^3$.

From Eqn. 7.29,

Period of free oscillations $T_0 = 2\pi\sqrt{J/K}$ or $4 = 2\pi\sqrt{\frac{1 \times 10^{-6}}{K}}$

\therefore Control constant $K = 2.47 \times 10^{-6} \text{ N-m/rad}$. Hence $G = 60 \times 2.47 \times 10^{-6} \times 10^3 = 148.2 \times 10^{-3}$

For critical damping resistance of galvanometer circuit

$$R = \frac{G^2}{2\sqrt{KJ}} = \frac{(148.2 \times 10^{-3})^2}{2\sqrt{2.47 \times 10^{-6} \times 1 \times 10^{-6}}} = 6990 \Omega$$

Example 7.6. A moving coil galvanometer has former of a non-conducting material. The current sensitivity of the instrument is $0.001 \mu\text{A/mm}$ at one metre. The period of undamped oscillations is 6 second. If the displacement constant of the instrument is $53 \times 10^{-3} \text{ N-m/A}$, calculate :

(i) control constant, (ii) inertia constant, (iii) total circuit resistance for instrument to be dead beat.

Solution : Suppose that the instrument is reflecting type. Therefore, if the final steady deflection is θ_F , the spot moves through an angle $2\theta_F$.

The spot moves a distance of 1 mm at 1 metre with a current of $0.001 \mu\text{A}$ or in other words a current of $0.001 \mu\text{A}$ deflects the instrument through

$$\theta_F = \frac{1}{2} \frac{I}{r} = \frac{1}{2} \times \frac{1}{10 \times 100} = 0.5 \times 10^{-3}$$

or control constant
$$K = \frac{G_t}{\theta_v} = \frac{0.05 \times 0.001 \times 10^{-6}}{0.5 \times 10^{-3}} = 100 \times 10^{-9} \text{ Nm/rad.}$$

Undamped period $T_0 = 2\pi \sqrt{J/K}$

or inertia constant
$$J = \frac{KT_0^2}{4\pi^2} = \frac{100 \times 10^{-9} \times (6)^2}{4\pi^2} = 91.2 \times 10^{-9} \text{ kg m}^2.$$

Total circuit resistance for critical damping or dead beat

$$R = \frac{G^2}{2\sqrt{KJ}} = \frac{(0.05)^2}{2\sqrt{100 \times 10^{-9} \times 91.2 \times 10^{-9}}} = 13100 \ \Omega.$$

Example 7.7. A d'Arsonval galvanometer has a rectangular coil wound on an aluminium former of resistivity $27 \times 10^{-9} \ \Omega\text{m}$. The sides of the former, each of effective length 30 mm, move in a radial field of uniform flux density 0.15 Wb/m^2 against a control torque of $18 \times 10^{-6} \text{ Nm/rad}$. The width of the former is 20 mm, the ends being effectively outside the magnet field, and the moment of inertia of the moving system is $80 \times 10^{-9} \text{ kg}\cdot\text{m}^2$.

Determine the cross-sectional area of the aluminium former if it is to provide critical damping, other sources of damping being neglected.

Solution: Total damping factor in the absence of all other damping except the damping produced by former is :

$$D = \frac{G^2}{N^2 R_f} = \frac{N^2 B^2 l^2 d^2}{N^2 R_f} = \frac{B^2 l^2 d^2}{R_f}$$

For critical damping

$$D = D_c = 2\sqrt{KJ}$$

$$\therefore \frac{B^2 l^2 d^2}{R_f} = 2\sqrt{KJ}$$

Hence resistance of former
$$R_f = \frac{B^2 l^2 d^2}{2\sqrt{KJ}} = \frac{(0.15)^2 \times (30 \times 10^{-3})^2 \times (20 \times 10^{-3})^2}{2\sqrt{18 \times 10^{-6} \times 80 \times 10^{-9}}} = 3375 \times 10^{-6} \ \Omega.$$

Length of eddy current paths $L = 2(l+d) = 2 \times (30+20) = 100 \text{ mm} = 0.1 \text{ m}$.

Let a be the area of cross-section of the aluminium former.

$$\therefore R_f = \frac{\rho L}{a} = \frac{27 \times 10^{-9} \times 0.1}{a} = 3.375 \times 10^{-6}$$

or area of cross-section of aluminium former
$$a = \frac{27 \times 10^{-9} \times 0.1}{3.375 \times 10^{-6}} = 0.8 \times 10^{-6} \text{ m}^2 = 0.8 \text{ mm}^2.$$

Example 7.8. The card attached to a galvanometer gives the following data :

Sensitivity = $0.004 \ \mu\text{A/mm}$, Coil resistance = $50 \ \Omega$, $CDRX = 300 \ \Omega$.

It is being used in bridge measurements with an Ayrton shunt of $500 \ \Omega$ resistance.

(a) Is the galvanometer overdamped or underdamped under this condition of use ? Explain briefly.

(b) What is the sensitivity of galvanometer with shunt at maximum setting.

(c) Where should the shunt be tapped to give a sensitivity 0.01 as great as in (b) ?

Solution: (a) With key K open (Fig. 7.9), the galvanometer has a closed circuit for damping through its own resistance and total resistance of shunt in series.

\therefore Total resistance in circuit
$$= R_m + R_s = 500 + 50 = 550 \ \Omega.$$

External resistance for critical damping

$$CDRX = 300 \ \Omega.$$

\therefore Resistance of circuit for critical damping
$$= CDRX + R_s = 300 + 50 = 350 \ \Omega.$$

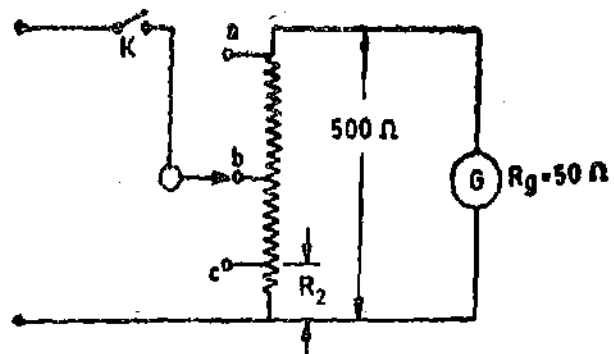

Fig. 7.9

The damping effect is large if the resistance of the galvanometer circuit is small. As the resistance of the galvanometer circuit ($= 550 \Omega$) is larger than the resistance ($= 350 \Omega$) required for critical damping, the galvanometer damping is smaller than critical. Hence the galvanometer is under-damped.

(b) Shunt at maximum setting means that whole of the resistance of the shunt is in parallel with the galvanometer. Therefore, the sliding contact is at 'a' for maximum setting.

Suppose $I \mu\text{A}$ is the total circuit current and $I_g \mu\text{A}$ is the current through the galvanometer with sliding contact at 'a'.

$$I_g = I \cdot \frac{R_{sh}}{R_{sh} + R_g} = I \cdot \frac{500}{500 + 50} = 0.909 I \mu\text{A}.$$

Now a current of $0.004 \mu\text{A}$ deflects the galvanometer through 1 mm and, therefore, deflection of galvanometer with a current $0.909 I$ micro ampere is :

$$d = \frac{0.909 I}{0.004} = 227.25 I \text{ mm} \quad \therefore \quad \text{Sensitivity} = \frac{I}{227.25 I} = 0.0044 \mu\text{A/mm}.$$

(In the problem the sensitivity is expressed in $\mu\text{A/mm}$ unlike our practice where sensitivity expressed in $\text{mm}/\mu\text{A}$.)

(c) The new value of sensitivity is 0.01 times as great as in (b).

$$\therefore \text{New value of sensitivity} = 0.0044 \times \frac{1}{0.01} = 0.44 \mu\text{A/mm}.$$

Suppose the slider contact is at 'c' when this sensitivity is obtained. The resistance being R_2 as indicated.

$$\text{Current through the galvanometer } I_g = I \cdot \frac{R_2}{R_2 + (R_{sh} - R_2 + R_g)} = I \cdot \frac{R_2}{R_{sh} + R_g} \\ = 1.82 \times 10^{-3} I R_2 \mu\text{A}.$$

$$\text{Deflection } d = 1.82 \times 10^{-3} I R_2 \times \frac{1}{0.004} = 0.455 I R_2 \text{ mm}.$$

$$\therefore \text{Sensitivity at 'c'} = \frac{I}{d} = \frac{I}{0.455 I R_2} = \frac{2.2}{R_2} \mu\text{A/mm}.$$

This should be to equal $0.44 \mu\text{A/mm}$

$$\text{or } \frac{2.2}{R_2} = 0.44 \quad \therefore \quad R_2 = \frac{2.2}{0.44} = 5 \Omega.$$

Example 79. The deflection of a galvanometer is zero with no current and 75 mm with a steady state current of $5.6 \mu\text{A}$. Its first maximum deflection, after a step function of voltage which produces a steady state current is applied is 112 mm. The maximum deflection in the next cycle is 84 mm. Determine (a) Current sensitivity, (b) the logarithmic decrement, and (c) relative damping.

$$\text{Solution : (a) Current sensitivity } S_t = \frac{\theta_F}{I} = \frac{75}{5.6} = 13.4 \text{ mm}/\mu\text{A}.$$

(b) and (c)

$$\text{First maximum deflection } \theta_1 = \theta_F [1 + e^{-\pi\zeta/\sqrt{1-\zeta^2}}] \quad \dots(i) \quad (\text{See Eqn. 7.53})$$

$$\text{Similarly second maximum deflection } \theta_3 = \theta_F [1 + e^{-3\pi\zeta/\sqrt{1-\zeta^2}}] \quad \dots(ii)$$

Hence from (i) and (ii),

$$\frac{\theta_1 - \theta_F}{\theta_3 - \theta_F} = \frac{e^{-\pi\zeta/\sqrt{1-\zeta^2}}}{e^{-3\pi\zeta/\sqrt{1-\zeta^2}}} = e^{2\pi\zeta/\sqrt{1-\zeta^2}}$$

But logarithmic decrement $\lambda = \frac{\pi\zeta}{\sqrt{1-\zeta^2}}$ (See Eqn. 7.57)

$$\therefore \frac{\theta_1 - \theta_r}{\theta_3 - \theta_r} = e^{-2\lambda} \quad \text{or} \quad \frac{112 - 75}{84 - 75} = e^{-2\lambda}$$

or Logarithmic decrement $\lambda = 0.707$

$$(c) \text{ Logarithmic decrement } \lambda = \frac{\pi\zeta}{\sqrt{1-\zeta^2}}$$

or $\lambda^2(1-\zeta^2) = \pi^2\zeta^2$, $\zeta^2(\pi^2 + \lambda^2) = \lambda^2$, $\zeta^2(9.87 + 0.5) = 0.5$ or relative damping $\zeta = 0.22$.

Example 7.10. The current sensitivity of a galvanometer is $100 \text{ mm}/\mu\text{A}$ with the scale 1 m away. The resistance of coil is 200Ω .

(a) Calculate the voltage sensitivity and the megohm sensitivity.

(b) What is the deflection produced by a current of $0.5 \mu\text{A}$ with the scale 0.75 m away from galvanometer?

(c) A resistance of 50Ω is placed in parallel with the coil. The scale is 1 m away from the galvanometer. Calculate the current sensitivity, voltage sensitivity, and the megohm sensitivity for the shunted galvanometer.

(d) The coil of the galvanometer is rewound. The area of the coil is not changed. The wire on the new coil has a diameter of one-half that of the original coil, but the total weight of the coil is the same. Calculate the current sensitivity, voltage sensitivity and megohm sensitivity.

Solution : (a) The current sensitivity with scale 1 m away is $100 \text{ mm}/\mu\text{A}$.

$$\text{Voltage sensitivity } S_v = \frac{d}{i \times R_g \times 10^{-6}} \text{ mm}/\mu\text{V} \quad (\text{See Eqn. 7.79})$$

$$= \frac{100}{1 \times 10^{-6} \times 200 \times 10^6} = 0.5 \text{ mm}/\mu\text{V}.$$

Current required for a deflection of 1 mm is $0.01 \mu\text{A}$.

$$\therefore \text{Megohm sensitivity } S_o = \frac{1}{0.01} = 100 \text{ M}\Omega/\text{mm}.$$

(b) The deflection produced at a distance of 0.75 m is $3/4$ of the deflection produced at a distance 1 m .

\therefore Deflection due to a current of $0.5 \mu\text{A}$ on a scale 0.75 m away $= 0.75 \times 0.5 \times 100 = 37.5 \text{ mm}$.

(c) The galvanometer resistance is 200Ω and that of shunt resistance is 50Ω . When a current of $1 \mu\text{A}$ is measured, $0.2 \mu\text{A}$ passes through the galvanometer and the rest through the shunt.

\therefore Current sensitivity $S_i = 0.2 \times 100 = 20 \text{ mm}/\mu\text{A}$. The voltage sensitivity remains the same.

Now a current of $1/20 \mu\text{A} = 0.05 \mu\text{A}$ is required for a deflection of 1 mm .

$$\therefore \text{Megohm sensitivity} = \frac{1}{0.05} = 20 \text{ M}\Omega/\text{mm}.$$

(d) Since the diameter of wire of the new coil is one half of the original, the volume of each turn of the new coil $\frac{1}{4}$ of that of original turn. Since the weight of the new coil is the same as that of original coil, the number of turns are 4 times that in the original coil.

Now the new coil has number of turns 4 times that of the original coil and area of each turn of new coil is $\frac{1}{4}$ of the original coil, the resistance of the new coil is 16 times that of the original coil.

Resistance of new coil = $16 \times 200 = 3200 \Omega$.

Displacement constant of new coil is 4 times that of the original coil.

Current sensitivity is directly proportional to the displacement constant.

\therefore Current sensitivity of new coil = $4 \times 100 = 400 \text{ mm}/\mu\text{A}$.

Voltage sensitivity is inversely proportional to resistance.

\therefore Voltage sensitivity of new coil = $\frac{0.5}{16} = 0.03125 \text{ mm}/\mu\text{V}$

Megohm sensitivity of the new coil = $400 \text{ M}\Omega/\text{mm}$.

Example 7.11. The following data refers to a moving coil galvanometer whose resistance is 460Ω and a resistance of 1970Ω is connected in series with it.

Number of turns	= 250
Flux density	= $0.1 \text{ Wb}/\text{m}^2$
Control constant	= $0.15 \times 10^{-6} \text{ Nm}/\text{rad}$
Dimensions of coil	= $30 \times 30 \text{ mm}$
Moment of inertia of coil	= $0.2 \times 10^{-6} \text{ kg m}^2$

Calculate :

(a) the resistance to be connected to galvanometer for critical damping (b) relative damping, (c) logarithmic decrement, (d) frequency of free damped oscillations, (e) period of undamped and damped oscillations, (f) first maximum deflection.

Solution : (a) Displacement constant $G = NBl d = 250 \times 0.1 \times 0.03 \times 0.03 = 22.5 \times 10^{-3} \text{ N}\cdot\text{m}/\text{A}$.

Let R be the total resistance of the circuit for critical damping.

$$\therefore \frac{G^2}{R} = 2\sqrt{KJ} \quad \text{or} \quad R = \frac{G^2}{2\sqrt{KJ}} = \frac{(22.5 \times 10^{-3})^2}{2\sqrt{0.15 \times 10^{-6} \times 0.2 \times 10^{-6}}} = 1460 \Omega$$

\therefore External resistance required for critical damping $CDRX = 1460 - 460 = 1000 \Omega$.

(b) Relative damping $\zeta = D/D_0$

$$= \frac{G^2/\text{resistance of circuit}}{G^2/\text{resistance of circuit for critical damping}} = \frac{G^2/1970 + 460}{G^2/1000 + 460} = 0.6.$$

$$(c) \text{ Logarithmic decrement } \lambda = \frac{\pi\zeta}{\sqrt{1-\zeta^2}} = \frac{\pi \times 0.6}{\sqrt{1-(0.6)^2}} = 2.36.$$

$$\text{Frequency of free oscillations } f_n = \frac{1}{2\pi} \sqrt{K/J} = \frac{1}{2\pi} \sqrt{\frac{0.15 \times 10^{-6}}{0.2 \times 10^{-6}}} = 0.138 \text{ Hz}$$

$$\text{Frequency of damped oscillations } f_d = f_n \sqrt{1-\zeta^2} = 0.138 \times \sqrt{1-(0.6)^2} = 0.11 \text{ Hz.}$$

$$(d) \text{ Period of undamped oscillations } T_0 = \frac{1}{f_n} = \frac{1}{0.138} = 7.24 \text{ s.}$$

$$\text{Period of damped oscillations } T_d = \frac{1}{f_d} = \frac{1}{0.11} = 9.1 \text{ s}$$

$$(e) \text{ First maximum deflection } \theta_1 = \theta_r \left(1 + e^{-\frac{\pi}{\sqrt{1-\zeta^2}}} \right) = \theta_r (1 + e^{-\lambda})$$

$$= \theta_r (1 + e^{-2.36}) = 1.0944 \theta_r$$

(See Eqns. 7.53 and 7.57)

Thus even with relative damping $\zeta=0.6$ the first maximum deflection is 9.44% (about 10%) more than the final steady deflection.

Example 7.12. A current galvanometer has the following parameters :

$B=10 \times 10^{-3}$ Wb/m², $N=200$ turns, $l=16$ mm, $d=16$ mm, $K=12 \times 10^{-9}$ Nm/rad, $J=50 \times 10^{-9}$ kg-m², $D=5 \times 10^{-9}$ Nm/rad s⁻¹. The resistance of the coil is 120 Ω .

Calculate (a) the deflection of the galvanometer in radian and in mm when a current of 1 μ A flows through it, the scale being 1 m away, (b) the current sensitivity, (c) the voltage sensitivity, (d) the megohm sensitivity, (e) the frequency of damped oscillations, (f) the period of free oscillations, (g) relative damping, (h) the first maximum deflection (i) the logarithmic decrement.

Solution : (a) Displacement constant $G=NBld=200 \times 10 \times 10^{-3} \times 10 \times 10^{-3} \times 16 \times 10^{-3}$
 $=0.512 \times 10^{-3}$ Nm/A.

$$\text{Deflection of galvanometer } \theta_F = \frac{Gi}{K} = \frac{0.512 \times 10^{-3} \times 1 \times 10^{-6}}{12 \times 10^{-9}} = 0.0427 \text{ rad.}$$

Deflection (in mm) = 2000 $\theta_F = 2000 \times 0.0427 = 85.4$ mm.

(b) A current of 1 μ A causes a deflection of 85.4 mm.

\therefore Current sensitivity $S_i = 85.4$ mm/ μ A.

(c) Voltage across the galvanometer for current of 1 μ A = $1 \times 10^{-6} \times 120 = 120 \times 10^{-6}$ V.
 The deflection corresponding to this voltage is 85.4 mm.

$$\therefore \text{Voltage sensitivity } S_v = \frac{85.4}{120 \times 10^{-6}} = 0.714 \times 10^{-6} \text{ mm/V} = 0.712 \text{ mm}/\mu\text{V.}$$

$$(d) \text{ Megohm sensitivity } S_o = \frac{d}{i \times 10^6} = \frac{85.4}{1 \times 10^{-6} \times 10^6} = 85.4 \text{ M}\Omega/\text{mm.}$$

(e) Frequency of damped oscillations

$$\omega_d = \frac{\sqrt{4KJ - D^2}}{2J} = \frac{\sqrt{4 \times 12 \times 10^{-9} \times 50 \times 10^{-9} - (5 \times 10^{-9})^2}}{2 \times 50 \times 10^{-9}} = 0.487 \text{ rad/s.}$$

$$\text{or } f_d = \frac{\omega_d}{2\pi} = \frac{0.487}{2 \times \pi} = 0.0775 \text{ Hz.}$$

(f) Frequency of natural oscillations

$$f_n = \frac{1}{2\pi} \sqrt{\frac{K}{J}} = \frac{1}{2\pi} \sqrt{\frac{12 \times 10^{-9}}{50 \times 10^{-9}}} = 0.078 \text{ Hz}$$

$$\text{Period of natural oscillation } T_o = \frac{1}{f_n} = \frac{1}{0.078} = 12.82 \text{ s}$$

(g) Damping constant required for critical damping

$$D_o = 2\sqrt{KJ} = 2\sqrt{12 \times 10^{-9} \times 50 \times 10^{-9}} = 49 \times 10^{-9} \text{ Nm/rad s}^{-1}$$

$$\text{Relative damping } \zeta = \frac{D}{D_o} = \frac{5 \times 10^{-9}}{49 \times 10^{-9}} = 0.102$$

(h) First maximum deflection

$$\theta_1 = \theta_F (1 + e^{-\pi \zeta / \sqrt{1 - \zeta^2}}) = \theta_F [1 + e^{-\pi \times 0.102 / \sqrt{1 - (0.102)^2}}]$$

$$= 1.72 \theta_F = 1.72 \times 85.4 = 147.2 \text{ mm}$$

$$(i) \text{ Logarithmic decrement } \lambda = \frac{\pi\zeta}{\sqrt{1-\zeta^2}} = \frac{\pi \times 0.102}{\sqrt{1-(0.102)^2}} = 0.322.$$

Example 7.13. Fig. 7.10 shows the circuit for testing of a galvanometer. The various values are : $E=1.5$ V, $R_1=1$ Ω and $R_2=7500$ Ω when $R_3=350$ Ω , the galvanometer deflection is 140 mm and when $R_3=1080$ Ω , the deflection is 50 mm.

Calculate, (a) the resistance of galvanometer, (b) the sensitivity of galvanometer, and (c) the value of resistance R_3 when the deflection is 70 mm.

Solution : Since the variable resistor R_3 is in a circuit which is in parallel with R_1 and also R_1 is very small as compared with R_2 , the variations of R_3 have no effect on the total current I_t . However, variation of R_3 changes the galvanometer current.

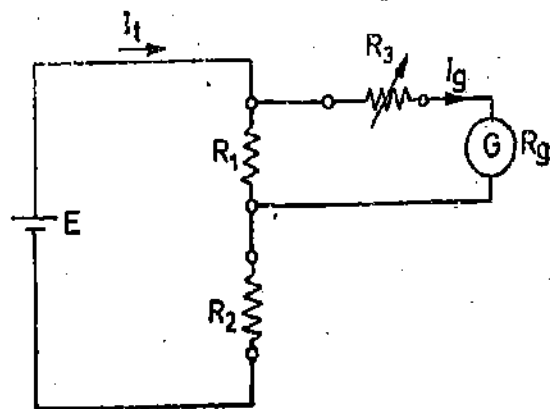

Fig. 7.10

$$(a) \text{ Galvanometer current } I_g = I_t \cdot \frac{R_1}{R_1 + R_3 + R_g}$$

$$\text{When } R_3 = 350 \text{ } \Omega, \text{ the galvanometer current is : } I_{g1} = I_t \cdot \frac{1}{1 + 350 + R_g} \quad \dots(i)$$

$$\text{When } R_3 = 1080 \text{ } \Omega, \text{ the galvanometer current is } I_{g2} = I_t \cdot \frac{1}{1 + 1080 + R_g} \quad \dots(ii)$$

The deflection of galvanometer with I_{g1} is 140 mm and that I_{g2} is 50 mm.

$$\therefore \frac{I_{g1}}{I_{g2}} = \frac{140}{50} \quad \dots(iii)$$

$$\text{From (i), (ii) and (iii), we have : } \frac{I_{g1}}{I_{g2}} = \frac{1 + 1080 + R_g}{1 + 350 + R_g} = \frac{14}{5}$$

or Galvanometer resistance $R_g = 54$ Ω .

(b) The total resistance of the circuit

$$R_t = R_2 + \frac{R_1(R_3 + R_g)}{R_1 + R_3 + R_g} \approx 7500 \text{ } \Omega \quad \therefore I_t = \frac{1.5}{7500} = 0.2 \times 10^{-3} \text{ A}$$

$$\text{For } R_3 = 350 \text{ } \Omega, \text{ galvanometer current } I_{g1} = 0.2 \times 10^{-3} \times \frac{1}{1 + 350 + 54} \\ = 0.494 \times 10^{-6} \text{ A} = 0.494 \text{ } \mu\text{A}.$$

$$\text{Deflection} = 140 \text{ mm. } \therefore \text{Current sensitivity } S_t = \frac{140}{0.494} = 283.4 \text{ mm}/\mu\text{A}.$$

(c) When $R_3 = 350$ Ω , the deflection is 140 mm. Therefore the galvanometer current at this setting is twice that gives a deflection 70 mm.

$$\therefore \text{ We have : } \frac{1 + R_3 + 54}{1 + 350 + 54} = 2 \quad \text{or } R_3 = 755 \text{ } \Omega.$$

Example 7.14. The following measurements were made on a panel type PMMC instrument which has a full scale deflection $90^\circ = 100$ scale divisions, with a current of 1 mA. The period of free oscillations is 0.55 s. In order to measure the spring constant, a small weight having a gravitational force of 98.1×10^{-6} N is placed at a distance of 100 mm from the horizontal axis of rotation with the horizontal pointer acting as lever arm, the resulting deflection being 35 divisions. The first maximum

deflection is 106 divisions when a current of 1 mA is suddenly passed through the meter. The value of flux density in the air gap measured with a Hall probe is 0.24 Wb/m^2 . The length of coil is 15 mm and the average diameter of coil is 14 mm. From the above data calculate: (a) spring constant, (b) moment of inertia, (c) number of turns, (d) damping ratio, (e) damping constant (f) equivalent resistance of the short circuited winding represented by the damping action of the former of the coil.

Solution : Full scale deflection $= 90^\circ = 100$ scale divisions

\therefore 1 scale division $= 0.9^\circ = 0.0157$ rad.

(a) Restoring torque $T_c = 98.1 \times 10^{-6} \times 100 \times 10^{-3} = 9.81 \times 10^{-6} \text{ Nm}$.

Deflection $\theta = 35 \text{ div.} = 35 \times 0.0157 \text{ rad} = 0.5495 \text{ rad}$.

\therefore Spring constant $K = \frac{T_c}{\theta} = \frac{9.81 \times 10^{-6}}{0.5495} = 17.85 \times 10^{-6} \text{ Nm/rad}$.

(b) Period of free oscillations $T_0 = 2\pi \sqrt{\frac{J}{K}}$

\therefore Moment of inertia $J = \frac{KT_0^2}{4\pi^2} = \frac{17.85 \times 10^{-6} \times 0.55^2}{4\pi^2} = 0.137 \times 10^{-6} \text{ kg-m}^2$.

(c) Control torque for a deflection of 35 scale divisions is $9.81 \times 10^{-6} \text{ Nm}$.

\therefore Control torque for full scale deflection (100 div.)

$$T_c = 9.81 \times 10^{-6} \times \frac{100}{35} = 28 \times 10^{-6} \text{ Nm}$$

\therefore Deflecting torque at full scale

$$T_d = NBldI = N \times 0.24 \times 15 \times 10^{-3} \times 14 \times 10^{-3} \times 1 \times 10^{-3} = 50.4 \text{ N} \times 10^{-9} \text{ Nm}$$

At equilibrium $T_d = T_c$ or $50.4 \text{ N} \times 10^{-9} = 28 \times 10^{-6}$

\therefore Number of turns $N = \frac{28 \times 10^{-6}}{50.4 \times 10^{-9}} = 556$.

(d) First maximum deflection $\theta_1 = 106$ divisions $= 1.06 \theta_r$

But $\theta_1 = \theta_r [1 + e^{-\pi \zeta / \sqrt{1 - \zeta^2}}]$

(See Eqn. 7.53)

or $1.06 = 1 + e^{-\pi \zeta / \sqrt{1 - \zeta^2}}$

$$\frac{\pi \zeta}{\sqrt{1 - \zeta^2}} = 2.81 \text{ or damping ratio } \zeta = 0.667$$

(e) Damping constant $D = \zeta \times 2\sqrt{KJ} = 0.667 \times 2 \times \sqrt{17.85 \times 10^{-6} \times 0.137 \times 10^{-6}}$
 $= 2.09 \times 10^{-6} \text{ Nm/rad s}^{-1}$.

(f) Considering the former to be a single turn coil, the damping constant is :

$$D_{\text{former}} = \frac{(Bld)^2}{R_f}$$

\therefore Resistance of former $R_f = \frac{(Bld)^2}{D_{\text{former}}} = \frac{(0.24 \times 15 \times 10^{-3} \times 14 \times 10^{-3})^2}{2.09 \times 10^{-6}} = 1.22 \times 10^{-3} \Omega$.

7.21. Ballistic Galvanometer. A ballistic galvanometer is used for measurement of quantity of electricity (charge) passed through it. In magnetic measurements, this quantity of electricity is due to an instantaneous emf induced in a search coil connected across the ballistic galvanometer. The instantaneous emf is induced in the search coil when the flux linking with the search coil is changed. The quantity of electricity passing through the galvanometer is proportional to the emf induced and

hence to the change in flux linking with the search coil. The galvanometer can therefore be calibrated to read the charge directly.

Construction. The ballistic galvanometer is of d'Arsonval type. However, it does not show a steady deflection (as is the case in a current galvanometer), owing to the transitory nature of the current passing through, but it oscillates with decreasing amplitude, the amplitude of the first deflection or swing or throw being proportional to the charge passing.

The proportionality between the throw of the galvanometer and the charge passing holds good only if the whole charge passes through the galvanometer coil before any appreciable deflection of the coil takes place. This condition can be satisfied if the time taken by the charge to pass is small and the time period of the undamped oscillations of the galvanometer is large.

The time period for undamped oscillations of a galvanometer is

$$T_0 = 2\pi \sqrt{J/K}$$

where J = inertia constant and K = control constant.

Thus to have a long time period, (it is usually 10 to 15 second) the moment of inertia of the moving system should be large and the control constant of the suspension should be small.

The above conditions can be satisfied by attaching small weights to the moving system in order to increase its moment of inertia and by using suspensions of smaller stiffness so as to decrease the control constant K .

The damping of the galvanometer should be small in order that the amplitude of the first swing is large. After the first swing has been observed, electromagnetic damping may be used to bring the coil rapidly to rest. This can be done by having a key connected across the galvanometer terminals; this key short circuits the galvanometer coil when closed.

Except for the above special features, the construction of a ballistic galvanometer is similar to a d'Arsonval type galvanometer.

Theory. It has been mentioned above that as long as charge passes through the meter there is no significant deflection of the moving system. The moving system deflects only after the charge has completely passed through the meter. The moving system has to deflect in order that the energy imparted to it by the charge is dissipated gradually in friction and electromagnetic damping. But during the actual motion, there is no deflecting torque as there is no current through the coil.

Supposing Q is the charge to be measured.

$$\therefore Q = \int i dt \quad \text{or} \quad i = \frac{dQ}{dt}$$

Let the instant of time during which the charge Q passes be defined as the time between $t=t_0=0$ and $t=t_1$. Between time interval t_0 to t_1 , there is no motion of the coil of the galvanometer and the equation of motion is

$$J \frac{d^2\theta}{dt^2} + D \frac{d\theta}{dt} + K\theta = Gi \quad \text{or} \quad J \frac{d^2\theta}{dt^2} + D \frac{d\theta}{dt} + K\theta = G \frac{dQ}{dt}$$

$$\text{For} \quad \frac{d^2\theta}{dt^2} = \frac{D}{J} \frac{d\theta}{dt} + \frac{K}{J} \theta = \frac{G}{J} \frac{dQ}{dt}$$

Integrating above gives

$$\frac{d\theta}{dt} \Big|_{t_0=0}^{t_1} + \frac{D}{J} \theta \Big|_{t_0=0}^{t_1} + \frac{K}{J} \int_0^{t_1} \theta dt = \frac{G}{J} Q \quad \dots(7'84)$$

But the deflection, θ , remains zero during the time interval t_0 to t_1 . Then Eqn. 7'84 becomes

$$\frac{d\theta}{dt} = \frac{G}{J} Q \quad \dots(7'85)$$

After passage of charge, *i.e.*, after the expiry of interval t_1 , no current passes through the coil of the galvanometer and hence the deflecting torque is zero. Thus the equation of motion after time t_1 is :

$$J \frac{d^2\theta}{dt^2} + D \frac{d\theta}{dt} + K\theta = 0$$

The solution of this equation is taken from Eqn. 7.17.

$$\theta = Fe^{-\frac{D}{2J}t} \left[\sin(\omega_n t + \phi) \right] + \theta_r$$

But in this case, the galvanometer does not show any steady state deflection and therefore $\theta_r = 0$.

Thus we have : $\theta = Fe^{-\frac{D}{2J}t} \left[\sin(\omega_n t + \phi) \right]$... (7.86)

Also since damping is small $\omega_n \approx \omega_n$. Hence $\theta = Fe^{-\frac{D}{2J}t} \left[\sin(\omega_n t + \phi) \right]$... (7.87)

Differentiating Eqn. 7.87 we have :

$$\frac{d\theta}{dt} = F\omega_n e^{-\frac{D}{2J}t} \left[\cos(\omega_n t + \phi) \right] - F e^{-\frac{D}{2J}t} \frac{D}{2J} \left[\sin(\omega_n t + \phi) \right]$$
 ... (7.88)

The initial conditions at $t=0$ are $\theta=0$ and $\frac{d\theta}{dt} = \frac{G}{J} Q$.

From Eqn. 7.87 we get, $F \sin \phi = 0$ or $\phi = 0$

and from Eqn. 7.88 $F = \frac{G}{J\omega_n} Q$... (7.89)

Hence Eqn. 7.87 can be written as : $\theta = \frac{G}{J\omega_n} Q e^{-\frac{D}{2J}t} \sin \omega_n t$... (7.90)

$$= \frac{G}{J} \cdot \sqrt{\frac{J}{K}} Q e^{-\frac{D}{2J}t} \sin \sqrt{\frac{K}{J}} t$$
 ... (7.91)

$$= A Q e^{-\frac{D}{2J}t} \sin \frac{2\pi}{T_0} t$$
 ... (7.92)

where

$$A = \frac{G}{J} \sqrt{\frac{J}{K}}$$
 ... (7.93)

It is evident from Eqn. 7.92, that the charge, Q , is proportional to the deflection, θ , at any instant. Also the motion of the galvanometer is oscillatory with a decreasing amplitude. The deflection time curve for the ballistic galvanometer is shown in Fig. 7.11.

The amplitude of the oscillations decreases with time. The maxima of successive oscillations occurs at

$$t = \frac{T_0}{4}, \frac{3T_0}{4}, \frac{5T_0}{4}, \text{ etc.}$$

$$\theta_1 = KQ e^{-\frac{D}{2J} \cdot \frac{T_0}{4}} \sin \frac{2\pi}{T_0} \cdot \frac{T_0}{4} = KQ e^{-\frac{D}{2J} \cdot \frac{T_0}{4}} \dots(7'94)$$

Putting the value of $T_0 = 2\pi\sqrt{J/K}$ in the above equation,

$$\theta_1 = AQ e^{-\frac{D}{2J} \cdot \frac{2\pi}{4} \sqrt{\frac{J}{K}}} = AQ e^{-\frac{\pi D}{4\sqrt{JK}}} \dots(7'95)$$

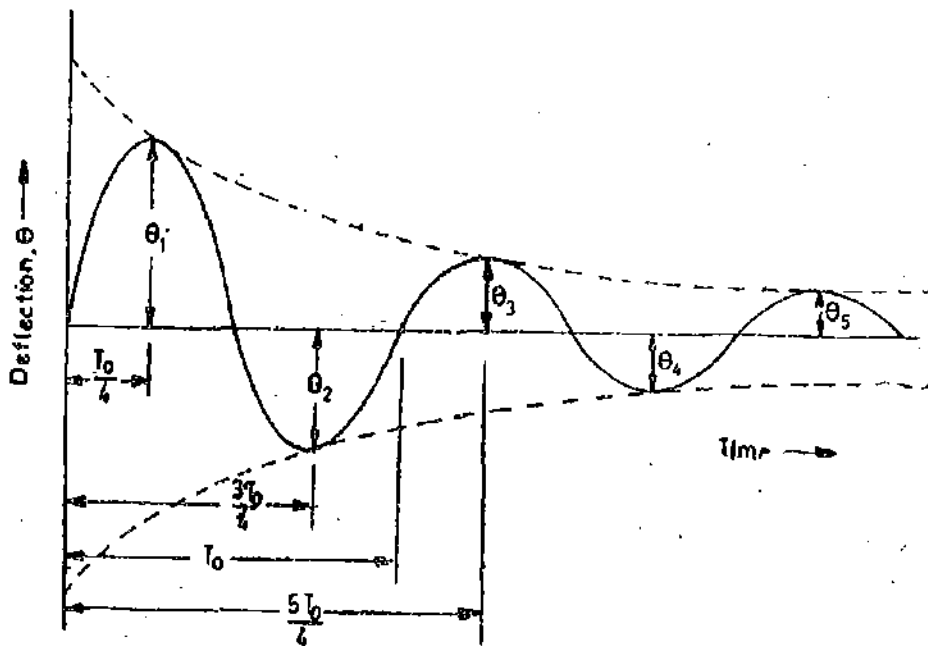

Fig. 7'11. Variation of deflection with time for a ballistic galvanometer.

Let us examine Eqn. 7'58 for logarithmic decrement.

Logarithmic decrement, $\lambda = \pi \zeta \frac{T_d}{T_0}$

For cases where damping is small, $T_d = T_0$ and $\therefore \lambda = \pi \zeta$

$$= \pi \frac{D}{D_0} = \frac{\pi D}{2\sqrt{KJ}} \dots(7'96)$$

Hence Eqn. 7'95 can be written as $\theta_1 = AQ e^{-\lambda/2}$... (7'97)

Similarly we can write $\theta_2 = AQ e^{-3\lambda/2}; \theta_n = AQ e^{-(2n-1)\lambda/2}$... (7'98)

Let us examine the case when the galvanometer is free from damping i.e., $D=0$. The equation of motion of an undamped galvanometer as derived from Eqn. 7'92 is :

$$\theta = AQ \sin \frac{2\pi}{T_0} t \dots(7'99)$$

Amplitude of swings of undamped oscillations is, therefore,

$$\theta_0 = AQ \sin \frac{2\pi}{T_0} \cdot \frac{T_0}{4} = AQ \dots(7'100)$$

The deflection-time curve for an undamped galvanometer is shown in Fig. 7'12.

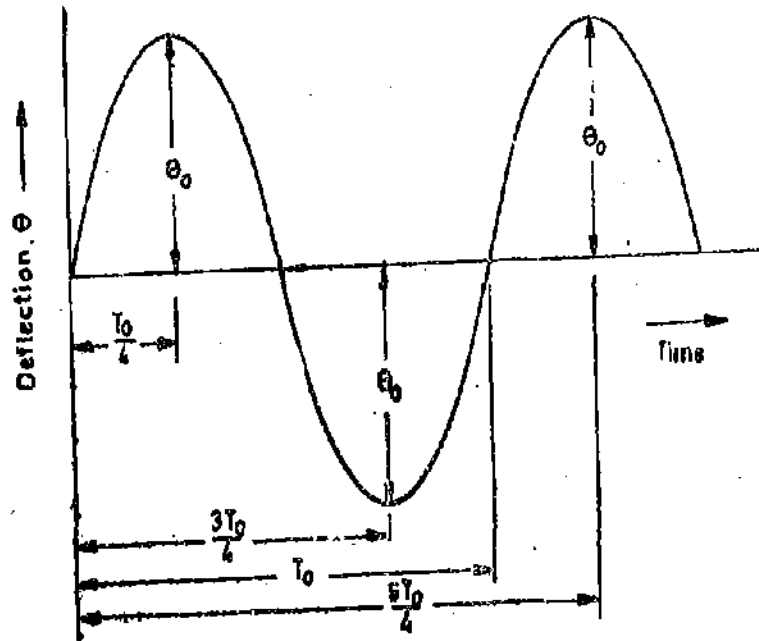

Fig. 7'12: Undamped oscillations.

Hence, we can write $\theta_1 = \theta_0 e^{-\lambda/2}$... (7'101)

$\theta_2 = \theta_0 e^{-3\lambda/2}$

.....

$\theta_n = \theta_0 e^{-(2n-1)\lambda/2}$... (7'102)

Logarithmic decrement is logarithm of ratio of successive swings.

\therefore Logarithmic decrement $\lambda = \log_e \left(\frac{\theta_1}{\theta_2} \right)$... (7'103)

Now ratio of successive swings is : $\frac{\theta_1}{\theta_2} = \frac{e^{-\lambda/2}}{e^{-3\lambda/2}} = e^\lambda$... (7'104)

Similarly, $\frac{\theta_2}{\theta_3} = e^\lambda$

.....

$\frac{\theta_{n-1}}{\theta_n} = e^\lambda$... (7'105)

From above we get $\frac{\theta_1}{\theta_2} \times \frac{\theta_2}{\theta_3} \times \frac{\theta_3}{\theta_4} \times \dots \times \frac{\theta_{n-1}}{\theta_n} = e^{(n-1)\lambda}$ or $\frac{\theta_1}{\theta_n} = e^{(n-1)\lambda}$

Hence logarithmic decrement is : $\lambda = \frac{1}{n-1} \log_e \left(\frac{\theta_1}{\theta_n} \right)$... (7'106)

From Eqn. 7'101, we have, $\theta_1 = \theta_0 e^{-\lambda/2}$ and therefore $\theta_0 = \theta_1 e^{\lambda/2}$... (7'107)

$= \theta_1 (1 + \lambda/2)$ approximately ... (7'108)

But $\theta_0 = AQ$ Hence $AQ = \theta_1 (1 + \lambda/2)$... (7'109)

\therefore Charge $Q = \frac{\theta_1}{A} (1 + \lambda/2)$... (7'110)

Substituting the value $A = \frac{G}{J} \sqrt{\frac{J}{K}}$ in the above expression we get :

Charge $Q = \frac{J}{G} \sqrt{\frac{J}{K}} \cdot \theta_1 (1 + \lambda/2) \dots (7.111)$

Now $T_0 = 2\pi \sqrt{\frac{J}{K}}$

\therefore Charge $Q = \frac{J}{G} \sqrt{\frac{J}{K}} \cdot \frac{T_0}{2\pi \sqrt{J/K}} \cdot \theta_1 (1 + \lambda/2) = \frac{K}{G} \frac{T_0}{2\pi} \theta_1 (1 + \lambda/2) \dots (7.112)$

Let us eliminate quantities K and G from above expression.

Suppose a steady current I_0 passing through the galvanometer produces a steady deflection θ .

$\therefore GI_0 = K\theta$ or $\frac{K}{G} = \frac{I_0}{\theta}$

Hence $Q = \frac{I_0}{\theta} \cdot \frac{T_0}{2\pi} (1 + \lambda/2) \theta_1 \dots (7.113)$

$= K_g \theta_1 \dots (7.114)$

where $K_g = \frac{I_0}{\theta} \cdot \frac{T_0}{2\pi} (1 + \lambda/2) \dots (7.115)$

$=$ constant of galvanometer,

Units of K_g are coulomb per radian.

7.22. Calibration of a Ballistic Galvanometer. Calibration of a galvanometer means the experimental determination of its constant. The various methods for determining the constant are :

1. Using a Mutual Inductance. The method is most commonly used for the calibration purposes. The mutual inductance is usually in the form of standard solenoid with a secondary coil. A standard solenoid consists of a long coil wound on a cylinder (Fig. 7.13). The length of the cylinder is very large as compared with its diameter. At the centre of the solenoid a secondary coil is placed. The axial length of the secondary coil is small.

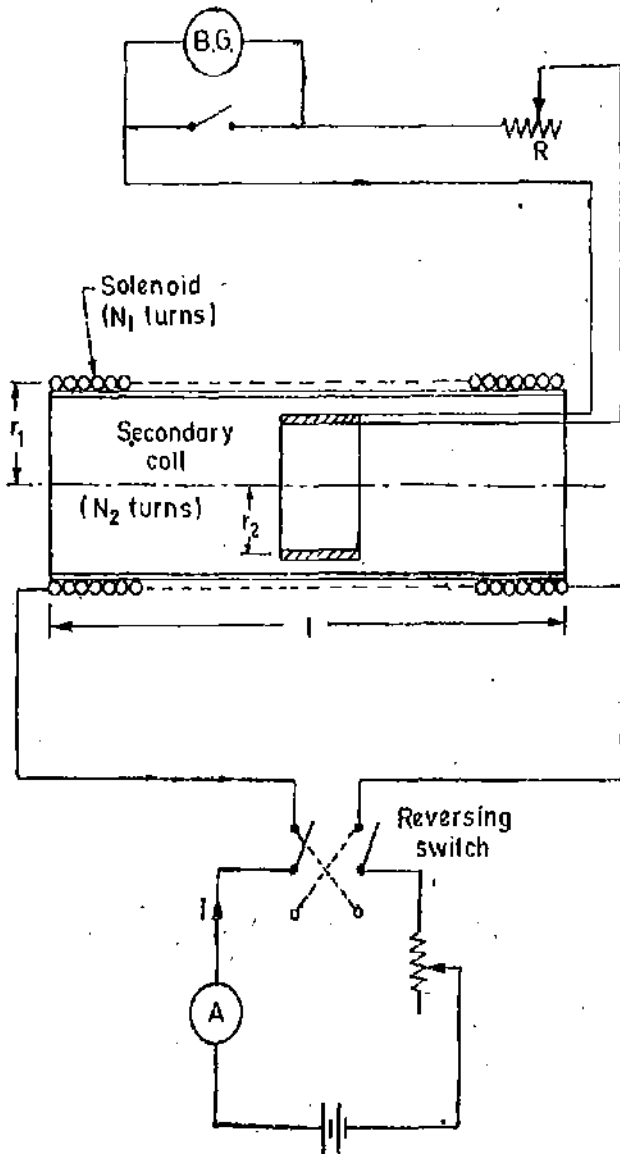

Fig. 7.13. Calibration of ballistic galvanometer with mutual inductance.

The secondary coil is connected to the ballistic galvanometer. When a current is passed through the solenoid, the field strength at the centre is :

$$H = \frac{N_1 I}{l} \cos \theta = \frac{N_1 I}{l} \cdot \frac{l/2}{\sqrt{(l/2)^2 + r_1^2}} = \frac{N_1 I}{\sqrt{(l/2)^2 + r_1^2}}$$

where N_1 = number of turns of the solenoid, I = current through the solenoid,
 l = length of solenoid and r_1 = mean radius of solenoid.

Flux density at the centre of solenoid $B = \mu_0 H$.

Flux linking with the secondary coil $\Phi = B \times \text{area of secondary coil} = B \times \pi r_2^2 = \pi B r_2^2 = \pi \mu_0 H r_2^2$
 where r_2 = mean radius of secondary coil.

Let N_2 be the number of turns in the secondary coil.

\therefore Flux linkages of secondary coil $\psi_2 = N_2 \Phi = \pi \mu_0 N_2 H r_2^2$.

Let the current through the solenoid be reversed. This will change the value of flux linking with secondary coil from $+\Phi$ to $-\Phi$.

Change in flux $= \Phi - (-\Phi) = 2\Phi$.

Change in flux linkages of secondary coil $= 2N_2 \Phi = 2\pi \mu_0 N_2 H r_2^2$.

Suppose θ_1 is the throw of the galvanometer

\therefore Constant of galvanometer in terms of flux linkages

$$K_\phi = \frac{2\pi \mu_0 N_2 H r_2^2}{\theta_1} \text{ weber turn per radian} \quad \dots(7'116)$$

$$= 2\pi \mu_0 N_2 \cdot \frac{N_1 I r_2^2}{2 \times \sqrt{\left(\frac{l}{2}\right)^2 + r_1^2}} \cdot \frac{1}{\theta_1} = \frac{\pi \mu_0 N_1 N_2 r_2^2}{\sqrt{\left(\frac{l}{2}\right)^2 + r_1^2}} \cdot \frac{I}{\theta_1} \text{ weber turn per radian}$$

We have M = mutual inductance between two coils $= \frac{\pi \mu_0 N_1 N_2 r_2^2}{2 \times \sqrt{\left(\frac{l}{2}\right)^2 + r_1^2}}$

The equivalent circuit with mutual inductance is shown in Fig. 7'14.

$$\therefore K_\phi = \frac{2MI}{\theta_1} \text{ weber turn per radian} \quad \dots(7'117)$$

Suppose the change in flux linkages takes place in time t .

\therefore Emf induced in the secondary coil

$$= \text{rate of change in flux linkages} = - \frac{d\psi}{dt}$$

$$= \frac{2\pi \mu_0 N_2 H r_2^2}{t}$$

This emf sends a current i through the galvanometer

$$i = \frac{2\pi \mu_0 N_2 H r_2^2}{Rt}$$

where R = galvanometer circuit resistance. Charge passing in time t

$$Q = it = \frac{2\pi \mu_0 N_2 H r_2^2}{R}$$

But $Q = K_c \theta_1$

where K_c = constant of galvanometer in coulomb per radian.

Constant of galvanometer

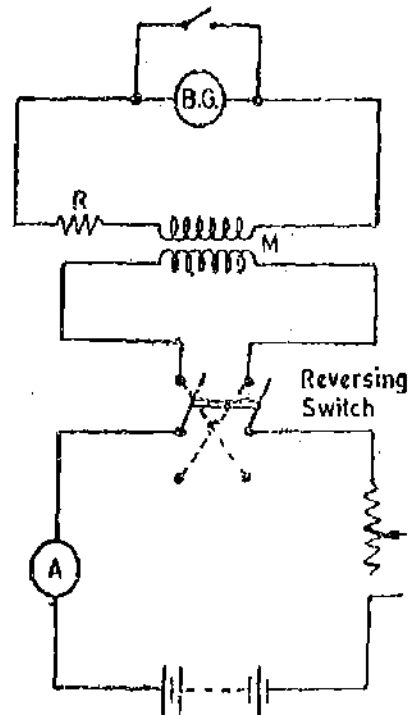

Fig. 7'14. Calibration of B.G. with mutual inductance.

$$K_g = \frac{Q}{\theta_1} = \frac{2\pi\mu_0 N_2 H r_2^2}{R} \frac{1}{\theta_1} = \frac{\pi\mu_0 N_1 N_2 r_2^2 I}{R \sqrt{\left(\frac{l}{2}\right)^2 + (r_1)^2}} = \frac{2MI}{R\theta_1} \quad \dots(7.118)$$

Thus the galvanometer constant can be obtained in terms of coulomb. per radian.

From the above analysis $K_g = \frac{K_\phi}{R} \quad \dots(7.119)$

Sometimes terms "Ballistic Sensitivity" and "Flux linkage sensitivity" are used in place of constants of galvanometers. These terms are defined as :

Ballistic sensitivity $S_g = \frac{\theta_1}{Q} \text{ rad/C} \quad \dots(7.120)$

and flux linkage sensitivity $S_\phi = \frac{\theta_1}{\Delta\psi} \text{ rad/Wb turn} \quad \dots(7.121)$

Naturally $S_g = \frac{1}{K_g} \quad \dots(7.122)$

and $S_\phi = \frac{1}{K_\phi} \quad \dots(7.123)$

Also $S_g = R S_\phi \quad \dots(7.124)$

2. Using a Capacitor. A capacitor is charged to a known emf E and is then discharged through the ballistic galvanometer. The throw of the galvanometer is observed. Let this throw be θ_1 .

\therefore Constant of galvanometer $K_g = \frac{Q}{\theta_1} = \frac{CE}{\theta_1} \text{ coulomb/radian}$

The circuit is shown in Fig. 7.15.

When the switch S is put at position 1, the capacitor C is charged to potential E . The switch is then put at position 2. At this position the capacitor is discharged through a resistance.

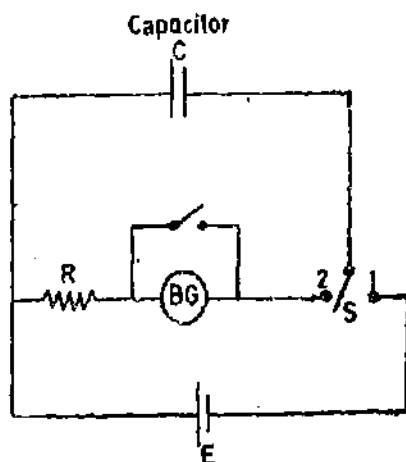

Fig. 7.15. Calibration of Ballistic galvanometer with capacitor.

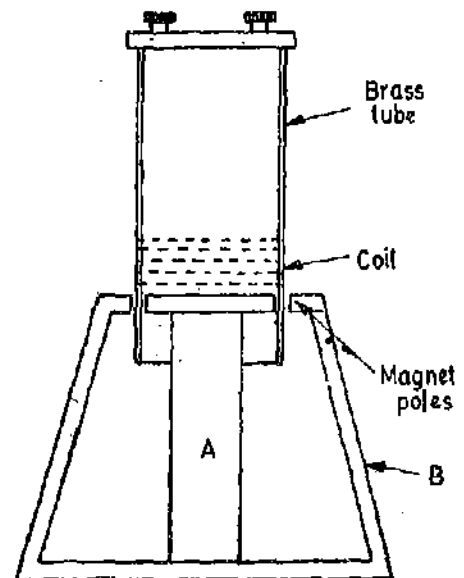

Fig. 7.16. Hibbert magnetic standard.

3. Using Hibbert Magnetic Standard. A Hibbert magnetic standard (Fig. 7.16) consists of a circular bar magnet and an iron yoke which has a narrow annular gap between them. A brass

tube carrying a coil can slide through the gap. The brass tube is taken to its top position and is then released with the help of a trigger. It falls under gravity and as it slides through the gap, its coil cuts through the magnetic field of the permanent magnet and therefore an emf is produced in the coil. The coil is connected across the terminals of the ballistic galvanometer. The throw of the B.G. (Ballistic Galvanometer) can be observed. The rate at which coil cuts through the field is constant for a particular apparatus. Thus emf per turn is constant. By the use of the standard the flux linkages which produce an observed throw of the galvanometer can be known by knowing the air gap flux and the number of turns in the coil. Hence the galvanometer constant can be evaluated.

7.23. Flux Meter

The flux meter is a special type of ballistic galvanometer in which the controlling torque is very small and the electromagnetic damping is heavy.

Construction. The construction of a flux meter is shown in Fig. 7.17. In general the construction is similar to that of a moving coil milli-ammeter. A coil of small cross-section is suspended from a spring support by means of a single silk thread. The coil moves in the narrow gap of a permanent magnet. There are no control springs.

The current is led into the coil with the help of a very loose helices of very thin, annealed silver strips. The controlling torque is thus reduced to minimum.

The coil is formerless and the air friction damping is negligible.

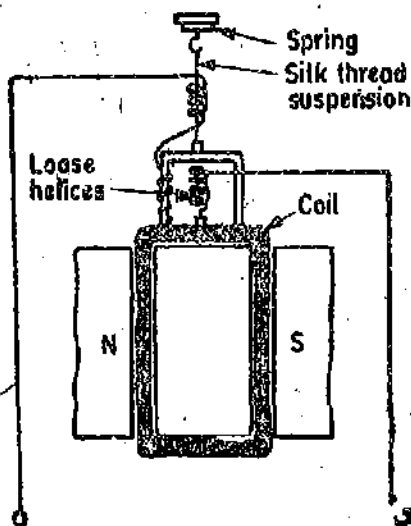

Fig. 7.17. Flux meter.

Operation. The terminals of the flux meter are connected to a search coil as shown in Fig. 7.18. The flux linking with the search coil is changed either by removing the coil from the magnetic field or by reversing the field. Due to the change in the value of flux linking with the search coil an emf is induced in it. This emf sends a current through the flux meter which deflects through an

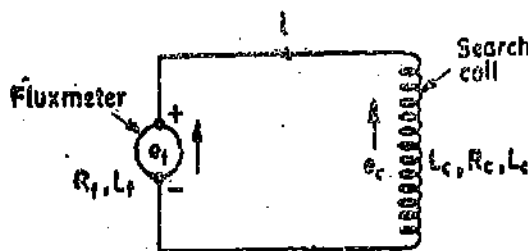

Fig. 7.18. Flux meter with search coil.

angle depending upon the change in the value of flux linkages. The instrument coil deflects during the period the flux linkages change but as soon as the change ceases the coil stops, owing to high electromagnetic damping in the coil circuit. This high electromagnetic damping is obtained by having a low resistance of the circuit comprising the flux meter and the search coil.

Theory. Let

- N = number of turns in the search coil,
- R_c, L_c = resistance and inductance of the search coil,
- R_f, L_f = resistance and inductance of flux meter,
- Φ = flux linking with the search coil,
- i = current in the circuit at any instant,
- and θ = deflection of the instrument at any instant.

The equation of motion is $T_c + T_D + T_C = T_a$ or $J \frac{d^2\theta}{dt^2} + D \frac{d\theta}{dt} + K\theta = GI$

It is assumed that the control torque is negligibly small and also the air friction damping is small. Therefore, the equation of motion reduces to :

$$J \frac{d^2\theta}{dt^2} = Gi \quad \dots(7'125)$$

as D and K are both zero. (The effect of electromagnetic damping is considered later in the expression for current i). The emf due to any change of flux linked with search coil :

$$e_c = N \frac{d\Phi}{dt}$$

At the same time, owing to the movement of the fluxmeter coil in the field of the magnet, a rotational emf is induced in the coil. Let this emf be e_r .

$$\therefore e_r = G \frac{d\theta}{dt}$$

Also there are voltage drops in the resistance and inductance of the circuit.

$$\text{Therefore we can write } e_c = e_r + (L_f + L_c) \frac{di}{dt} + (R_f + R_c)i$$

$$\text{or } N \frac{d\Phi}{dt} = G \frac{d\theta}{dt} + (L_f + L_c) \frac{di}{dt} + (R_f + R_c)i \quad \text{or } i = \frac{N \frac{d\Phi}{dt} - G \frac{d\theta}{dt} - (L_f + L_c) \frac{di}{dt}}{R_f + R_c}$$

$$\text{Therefore, equation of motion is : } J \frac{d^2\theta}{dt^2} = \frac{G}{R_f + R_c} \left[N \frac{d\Phi}{dt} - G \frac{d\theta}{dt} - (L_f + L_c) \frac{di}{dt} \right]$$

$$\text{or } N \frac{d\Phi}{dt} = \frac{J(R_f + R_c)}{G} \frac{d^2\theta}{dt^2} + G \frac{d\theta}{dt} + (L_f + L_c) \frac{di}{dt}$$

$$= \frac{J(R_f + R_c)}{G} \frac{d\omega}{dt} + G \frac{d\theta}{dt} + (L_f + L_c) \frac{di}{dt}$$

where ω = angular velocity of moving coil at any instant t .

Now if the time taken by change in flux is T , we have :

$$\int_0^T N \frac{d\Phi}{dt} dt = \int_0^T \frac{J(R_f + R_c)}{G} \frac{d\omega}{dt} dt + \int_0^T G \frac{d\theta}{dt} dt + \int_0^T (L_f + L_c) \frac{di}{dt} dt$$

$$\text{or } \int_{\Phi_1}^{\Phi_2} N d\Phi = \int_{\omega_1}^{\omega_2} \frac{J(R_f + R_c)}{G} d\omega + \int_{\theta_1}^{\theta_2} G d\theta + \int_{i_1}^{i_2} (L_f + L_c) di$$

$$\therefore N(\Phi_2 - \Phi_1) = \frac{J(R_f + R_c)}{G} (\omega_2 - \omega_1) + G(\theta_2 - \theta_1) + (L_f + L_c)(i_2 - i_1) \quad \dots(i)$$

where Φ_1 and Φ_2 are the interlinking fluxes ω_1 and ω_2 are the angular velocities, θ_1 and θ_2 are the deflections and i_1 and i_2 are the currents ; suffixes 1 and 2 indicate respectively values at the beginning and at the end of the change.

But angular velocities and currents are zero at both the beginning and the end of the change

$$\text{i.e., } \omega_1 = \omega_2 = 0 \quad \text{and } i_1 = i_2 = 0$$

$$\text{Putting these values in (i), } N(\Phi_2 - \Phi_1) = G(\theta_2 - \theta_1) \quad \dots(7'126)$$

or if Φ is the change in the flux and θ the change in flux meter deflection

$$\Phi = \frac{G}{N} \theta \quad \dots(7'127)$$

If the flux meter permanent magnet field is uniform for all positions of the moving coil, G is a constant. Thus the change in the value of flux is directly proportional to the change in the deflection and hence the instrument will have a uniform scale.

724. Use of Shunt with Fluxmeter. If a very large value of flux is to be measured, the deflection of the flux meter may exceed the scale length even when a single turn search coil is used. For such measurements, the range of the flux meter may be extended by using a shunt.

The circuit using a shunt with a fluxmeter is shown in Fig. 719.

Let

R_c, R_f, R_s = resistance of search coil, fluxmeter and shunt respectively,

L_c, L_f = inductance of search coil and fluxmeter respectively,

i_c, i_f, i_s = current through search coil, fluxmeter and shunt respectively,

e_c = emf induced in the search coil because of change in flux linkages

$$= N \frac{d\Phi}{dt}$$

e_f = emf generated in the fluxmeter coil because of rotation = $G \frac{d\theta}{dt}$

Applying Kirchhoff's law for the mesh $ABCF$, $e_c = i_c R_c + L_c \frac{di_c}{dt} + i_f R_f + L_f \frac{di_f}{dt} + e_f$

or
$$N \frac{d\Phi}{dt} - L_c \frac{di_c}{dt} - L_f \frac{di_f}{dt} - G \frac{d\theta}{dt} = i_c R_c + i_f R_f$$

Integrating as before, we have :

$$\begin{aligned} & N(\Phi_2 - \Phi_1) - L_c(i_{c2} - i_{c1}) - L_f(i_{f2} - i_{f1}) - G(\theta_2 - \theta_1) \\ &= R_c \int_0^T i_c dt + R_f \int_0^T i_f dt. \end{aligned}$$

Now currents are zero at both the beginning and end of the flux change

or $i_{c2} = i_{c1} = 0, i_{f2} = i_{f1} = 0.$

Therefore, we can write $N(\Phi_2 - \Phi_1) - G(\theta_2 - \theta_1) = R_c \int_0^T i_c dt + R_f \int_0^T i_f dt. \dots(ii)$

The equation of motion is $J \frac{d^2\theta}{dt^2} = Gi_f$ or $i_f = \frac{J}{G} \frac{d^2\theta}{dt^2} = \frac{J}{G} \frac{d\omega}{dt}$

where ω is the angular velocity at any instant.

Hence $\int_0^T i_f dt = \frac{J}{G} \int_0^T \frac{d\omega}{dt} dt = \frac{J}{G} \int_{\omega_1}^{\omega_2} d\omega$ or $\int_0^T i_f dt = \frac{J}{G} (\omega_2 - \omega_1)$

But $\omega_2 = \omega_1 = 0,$

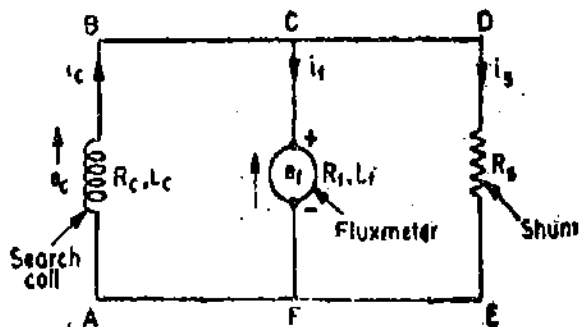

Fig. 719. Fluxmeter with shunt.

$$\text{Therefore } \int_0^T i_f dt = 0.$$

$$\text{Hence (ii) reduces to } N(\Phi_2 - \Phi_1) - G(\theta_2 - \theta_1) = R_o \int_0^T i_o dt \quad \dots(iii)$$

Let us apply Kirchhoff's law to mesh *CDEF*, we have :

$$e_f + L_f \frac{di_f}{dt} + i_f R_f = i_s R_s$$

$$\text{or } G \frac{d\theta}{dt} + L_f \frac{di_f}{dt} = -i_f R_f + i_s R_s = -i_f R_f + (i_o - i_f) R_s$$

$$\text{or } G \frac{d\theta}{dt} + L_f \frac{di_f}{dt} = -(R_f + R_s) i_f + i_o R_s$$

$$\text{Integrating as before } G(\theta_2 - \theta_1) + L_f(i_{f2} - i_{f1}) = -(R_f + R_s) \int_0^T i_f dt + R_s \int_0^T i_o dt$$

$$\text{But } i_{f2} = i_{f1} = 0 \text{ and } \int_0^T i_f dt = 0$$

$$\text{Hence } G(\theta_2 - \theta_1) = R_s \int_0^T i_o dt \quad \text{or} \quad \int_0^T i_o dt = \frac{G(\theta_2 - \theta_1)}{R_s}$$

Substituting this value of $\int_0^T i_o dt$ in (iii), we get :

$$N(\Phi_2 - \Phi_1) - G(\theta_2 - \theta_1) = \frac{R_o}{R_s} G(\theta_2 - \theta_1) \quad \text{or} \quad N(\Phi_2 - \Phi_1) = G \frac{R_o + R_s}{R_s} (\theta_2 - \theta_1) \quad \dots(7.128)$$

If $(\Phi_2 - \Phi_1) = \Phi$ and $(\theta_2 - \theta_1) = \theta$,

$$\text{we have } \Phi = \frac{G}{N} \cdot \frac{R_o + R_s}{R_s} \theta \quad \dots(7.129)$$

Comparison of Eqn. 7.129 with corresponding Eqn. 7.127 of unshunted fluxmeter shows that the multiplying factor for the shunted flux meter is :

$$m = \frac{R_s + R_o}{R_s} \quad \dots(7.130)$$

Note. The theory of the unshunted fluxmeter shows (see Eqn. 7.127) that the value of resistance of either the fluxmeter or the search coil does not affect the meter sensitivity. However, the value of total circuit resistance should not exceed about 20 ohm otherwise the damping will not be adequate. The theory of a shunted fluxmeter shows that the resistance R_s of the search coil is important when the meter is shunted. The resistance R_f of the meter is unimportant.

The theory also shows the inductance of search coil and the fluxmeter are immaterial and that the time for flux change has no effect on the indication of the fluxmeter. This time may be as

much as 2 minutes in some cases, however, in practice, if the time exceeds about 30 seconds, serious errors are introduced because of friction, little control torque exerted by the current leads and the effect of improper levelling etc.

Advantages and Disadvantages

Advantages. (i) The industrial form of fluxmeter is portable,

(ii) Its scale is directly calibrated in weber turns,

(iii) The indication of the meter is independent of the time taken by the flux change. This is of great importance in measurement of flux linking with highly inductive circuits where the flux changes may be relatively slow rendering the use of ballistic galvanometers impractical.

Disadvantages. (i) The fluxmeter is less sensitive and accurate than the ballistic galvanometer.

Example 7.15. The coil of a ballistic galvanometer has 115 turns of mean area $25 \times 40 \text{ mm}^2$. The flux density in the air gap is 0.12 Wb/m^2 and the moment of inertia is $0.5 \times 10^{-6} \text{ kg-m}^2$. The stiffness is $45 \times 10^{-8} \text{ Nm/rad}$. What current must be passed to give a deflection of 100° and what resistance must be added in series with the movement to give critical damping?

Solution. Displacement constant $G = NBA = 115 \times 0.12 \times 25 \times 40 \times 10^{-6} = 138 \times 10^{-3} \text{ N-m/A}$.

Deflection $\theta = 100^\circ = 1.475 \text{ rad}$ But $i = \frac{K\theta}{G} = \frac{4.5 \times 10^{-6}}{138 \times 10^{-3}} \times 1.475 = 4.8 \times 10^{-3} \text{ A} = 4.8 \text{ mA}$.

For critical damping, damping constant, $D = 2\sqrt{KJ} = 2\sqrt{45 \times 10^{-8} \times 0.5 \times 10^{-6}}$
 $= 9.48 \times 10^{-6} \text{ (Nm/rad-s}^{-1}\text{)}$.

Neglecting the resistance of the galvanometer coil, external resistance required for critical damping is:

$$CDRX = \frac{G^2}{D} = \frac{(138 \times 10^{-3})^2}{9.48 \times 10^{-6}} = 2000 \text{ } \Omega.$$

Example 7.16. A solenoid 1 m long and wound with 800 turns has a search coil of 50 turns and cross-sectional area 300 mm^2 at its centre. Reversing a current of 4 A in the solenoid causes a deflection of 5 divisions in a ballistic galvanometer connected to the search coil. Calculate the galvanometer constant in flux linkages per division. Calculate also the flux linkage sensitivity.

Solution:

Flux density at the centre of solenoid $B = \mu_0 \frac{N_1 I}{l}$.

Flux linking with search coil $\Phi = BA = \frac{\mu_0 N_1 I A}{l}$.

Flux linkages of search coil $\psi = N_2 BA = \frac{\mu_0 N_1 N_2 I A}{l}$.

Change of flux linkages $\Delta\psi = 2\psi = \frac{2\mu_0 N_1 N_2 I A}{l}$.

Galvanometer constant $K_\phi = \frac{2\psi}{\theta_1} = \frac{2\mu_0 N_1 N_2 I A}{l\theta_1}$.

$$= \frac{2 \times 4\pi \times 10^{-7} \times 800 \times 50 \times 4 \times 300 \times 10^{-6}}{1 \times 5} = 24.1 \times 10^{-6} \text{ weber turn per division.}$$

Flux linkage sensitivity $S_\phi = \frac{1}{K_\phi} = \frac{1}{24.1 \times 10^{-6}} = 41.5 \times 10^3 \text{ divisions per weber turn.}$

Example 7.17. The mutual inductance between magnetizing winding and a search coil wound

on a specimen is 9 mH. The search coil has 20 turns and the specimen has a cross-sectional area of 500 mm². Reversal of a current of 3 A in magnetising winding produces a galvanometer throw of 60 divisions. Calculate the value of the flux density in a specimen if the reversal of current in the magnetizing winding produces a galvanometer deflection of 36 divisions.

Solution : Flux linkages of search coil $\psi = MI$.

Change in flux linkages $\Delta\psi = 2\psi = 2MI$.

Galvanometer constant $K_{\phi} = \frac{2\psi}{\theta_1} = \frac{2MI}{\theta_1} = \frac{2 \times 9 \times 10^{-3} \times 3}{60} = 0.9 \times 10^{-3}$ weber turn per division.

With a galvanometer throw of 36 divisions,

Change in flux linkages $\Delta\psi = 2\psi = 36 \times 0.9 \times 10^{-3} = 324 \times 10^{-3}$ weber turn.

Original flux linkages $\psi = 162 \times 10^{-3}$ weber turn.

Flux in specimen $\Phi = \frac{\psi}{N_2} = \frac{162 \times 10^{-3}}{20} = 0.81 \times 10^{-3}$ Wb.

Flux density $B = \frac{\Phi}{A} = \frac{0.81 \times 10^{-3}}{500 \times 10^{-6}} = 1.62$ Wb/m².

Example 7.18. A ballistic galvanometer has a resistance of 150 Ω and an undamped period of 7.5 s. A steady emf of 3.5 mV produces a deflection of 210 mm. Determine the quantity of electricity discharged from a capacitor if the deflection produced is 750 mm. The relative damping is 0.8.

Solution : Steady state current $I_s = \frac{3.5 \times 10^{-3}}{150} = 23.3 \times 10^{-6}$ A.

Under steady state conditions :

$$K\theta = G I_s$$

$$\therefore \frac{K}{G} = \frac{I_s}{\theta} = \frac{23.3 \times 10^{-6}}{210} = 0.11 \times 10^{-6} \text{ A/mm.}$$

Logarithmic decrement $\lambda = \frac{\pi\zeta}{\sqrt{1-\zeta^2}}$

(See Eqn. 7.57)

$$= \frac{\pi \times 0.8}{\sqrt{1-(0.8)^2}} = 4.19.$$

From Eqn. 7.112, quantity of electricity $Q = \frac{K}{G} \cdot \frac{T_0}{2\pi} (1 + \lambda/2)\theta_1$

$$= 0.11 \times 10^{-6} \times \frac{7.5}{2\pi} \left(1 + \frac{4.19}{2}\right) \times 750 = 304.8 \times 10^{-6} \text{ C} = 304.8 \mu\text{C.}$$

Example 7.19. The discharge of a capacitor through a ballistic galvanometer produces a damped frequency of 0.125 Hz and successive swings of 120, 96 and 76.8 mm; calculate the damping ratio. Also determine the logarithmic decrement and period of undamped and damped oscillations.

Solution. From Eqn. 7.106, logarithmic decrement

$$\lambda = \frac{1}{n-1} \log_e \frac{\theta_1}{\theta_n} = \frac{1}{(3-1)} \log_e \frac{120}{76.8} = 0.223$$

Period of damped oscillations $T_d = \frac{1}{f_d} = \frac{1}{0.125} = 8$ s.

From Eqn. 7.57, logarithmic decrement $\lambda = \frac{\pi\zeta}{\sqrt{1-\zeta^2}}$

$$\text{Damping ratio } \zeta = \sqrt{\frac{\lambda^2}{\pi^2 + \lambda^2}} = \sqrt{\frac{(0.223)^2}{\pi^2 + (0.223)^2}} = 0.0708$$

$$\text{Frequency of undamped oscillations } f_0 = \frac{f_d}{\sqrt{1-\zeta^2}} = \frac{0.125}{\sqrt{1-(0.0708)^2}} = 0.1256 \text{ Hz}$$

$$\text{Period of undamped oscillations } T_0 = \frac{1}{0.1256} = 7.96 \text{ s.}$$

Example 7.20 A moving coil ballistic galvanometer of 150Ω resistance gives a throw of 75 divisions when the flux through a search coil to which it is connected is reversed. Find the flux density in which the reversal of the coil takes place, given that the galvanometer constant $= 110 \mu\text{C}/\text{div.}$, and the search coil has 1400 turns, a mean area of 5000 mm^2 and a resistance of 20Ω .

Calculate also the ballistic and flux linkage sensitivities of the galvanometer.

Solution. Resistance of galvanometer circuit $= 20 + 150 = 170 \Omega$.

Galvanometer constant $K_g = 110 \mu\text{C}/\text{div.}$

$$\text{Now } K_g = \frac{Q}{\theta_1} = \frac{It}{\theta_1} = \frac{e}{R\theta_1}$$

But change in flux linkages $\Delta\psi = 2\psi$

$$\therefore e = \frac{2\psi}{t} = \frac{2\Phi N}{t} = \frac{2BAN}{t} \quad \text{Hence } K_g = \frac{2BAN}{t} \cdot \frac{t}{R\theta_1} = \frac{2BAN}{R\theta_1}$$

$$\text{Flux density } B = \frac{K_g R \theta_1}{2AN} = \frac{110 \times 10^{-6} \times 170 \times 75}{2 \times 5000 \times 10^{-6} \times 1400} = 0.1 \text{ Wb/m}^2.$$

$$\text{Ballistic sensitivity } S_g = \frac{1}{K_g} = \frac{1}{110} = 9.1 \times 10^{-3} \text{ div./}\mu\text{C} = 9100 \text{ div./C.}$$

$$\text{Flux linkage sensitivity } S_\psi = \frac{S_g}{R} = \frac{9100}{150} = 60.7 \text{ weber turn/div.}$$

Example 7.21. A ballistic galvanometer gives a first maximum deflection of 60° for a discharge of $1000 \mu\text{C}$. Find the quantity of electricity which when discharged through this galvanometer gives rise to a spot deflection of 10 divisions on a millimeter circular scale 1 metre away.

Solution Let us assume that angular deflection of 60° is the deflection of the reflected ray from the mirror attached to the moving coil.

$$\text{Charge } Q = K_g \theta_1 \quad \text{Now } \theta_1 = 60^\circ = \pi/3 \text{ rad.}$$

$$\therefore K_g = \frac{1000}{\pi/3} = \frac{3000}{\pi} \mu\text{C}/\text{rad.}$$

$$\text{Angle turned through by reflected ray for a swing of 10 mm is : } \theta = \frac{l}{r} = \frac{10}{1000} = 0.01 \text{ rad.}$$

$$\therefore \text{Charge for a swing of } 0.01 \text{ radian is : } Q = \frac{3000}{\pi} \times 0.01 = 9.56 \mu\text{C.}$$

Example 7.22. A galvanometer with an undamped period of 9 second and a current sensitivity of 1 microampere per scale division is connected to a search coil in a circuit of 4000Ω resistance. Determine the flux linkage change in the search coil to produce a first swing of .00 divisions if the logarithmic decrement is 0.2.

Solution :

$$\text{Charge } Q = \frac{T_0}{2\pi} \frac{I_2}{\theta} (1 + \lambda/2) \theta_1 = \frac{9}{2\pi} \times 1 \times 10^{-6} \left(1 + \frac{0.2}{2} \right) \times 100 = 158 \times 10^{-6} \text{ C.}$$

Let $\Delta\psi$ be the change in flux linkages in time t

$$\therefore \text{emf } e = \frac{\Delta\psi}{t} \quad \text{Charge } Q = it = \frac{e}{R} \cdot t = \frac{\Delta\psi}{R}$$

$$\therefore \text{Change in flux linkage } \Delta\psi = RQ = 4000 \times 158 \times 10^{-6} = 632 \times 10^{-3} \text{ weber turn.}$$

Example. 7.23. A certain flux meter has the following constants :

Air gap flux density = 0.05 Wb/m^2 , Turns on moving coil = 40, Area of moving coil = 750 mm^2 .
If a 10 turn search coil of 200 mm^2 area connected to the fluxmeter is reversed in uniform field of 0.5 Wb/m^2 , calculate the deflection of the fluxmeter.

$$\text{Solution. Constant of flux meter } G = 40 \times 0.05 \times 750 \times 10^{-6} = 1500 \times 10^{-6}$$

$$\text{Flux linking with search coil} = 0.5 \times 200 \times 10^{-6} = 100 \times 10^{-6} \text{ Wb.}$$

$$\text{Change in flux linking the coil} = 2 \times 100 \times 10^{-6} = 200 \times 10^{-6} \text{ Wb.}$$

$$\text{From Eqn. 7.127, change in flux } \Phi = \frac{G}{N} \theta$$

$$\therefore \text{Deflection } \theta = \frac{N\Phi}{G} = \frac{10 \times 200 \times 10^{-6}}{1500 \times 10^{-6}} \text{ rad.} = 76.5^\circ$$

Example. 7.24. A fluxmeter is connected to a search coil having 500 turns and a mean area of 500 mm^2 . The search coil is placed at the centre of a solenoid 1 metre long, wound with 800 turns. When a current of 5 A is reversed, there is a deflection of 25 scale divisions. Calculate the calibration in flux linkages per scale division.

$$\text{Solution. Field strength of solenoid } H = \frac{N_1 I}{l} = \frac{800 \times 5}{1} = 4000 \text{ A/m.}$$

$$\text{Flux density } B = \mu_0 H = 4\pi \times 10^{-7} \times 4000 = 16\pi \times 10^{-3} \text{ Wb/m}^2.$$

$$\text{Flux linkages of fluxmeter search coil} = N_2 BA = 500 \times 16\pi \times 10^{-3} \times 500 \times 10^{-6} \\ = 0.4\pi \times 10^{-3} \text{ weber turn.}$$

$$\text{Change in flux linkages} = 2 \times (0.4\pi \times 10^{-3}) = 0.8\pi \times 10^{-3} \text{ weber turn.}$$

$$\text{Flux linkages per scale division} = \frac{0.8\pi \times 10^{-3}}{25} = 0.1005 \times 10^{-3} \text{ weber turn per scale division.}$$

Example 7.25. A fluxmeter when used with a single turn search coil gives full scale deflection when a given uniform field linking with the search coil is reversed. It is proposed to extend the range of fluxmeter to measure flux densities five times the above value using the same search coil and method of reversals. If the resistance of search coil is 1Ω , find the resistance of the shunt to be connected in parallel with the fluxmeter.

Solution. From Eqn. 7.130, the range of instrument is extended $(R_c + R_s)/R_s$ times by use of a shunt.

where R_c = resistance of search coil and R_s = resistance of shunt.

$$\text{Now, we have } \frac{R_c + R_s}{R_s} = 5 \text{ or } \frac{1 + R_s}{R_s} = 5$$

$$\text{Resistance of shunt } R_s = 0.25 \Omega.$$

Example 7.26. The reluctance of a magnetic circuit excited by an mmf of 8000 A is $120,000 \text{ A/Wb}$. A fluxmeter is used to measure the flux. If the fluxmeter scale has 120 divisions and the flux linkages required for a deflection of 1 division has 0.15×10^{-3} weber turn, calculate the resistance

of the shunt required for use with the search coil. Number of turns of search coil is 1 and its resistance is 0.025Ω . The measurement is made by switching off the excitation.

$$\text{Solution. Flux to be measured} = \frac{\text{mmf}}{\text{reluctance}} = \frac{8000}{120,000} = 66.7 \times 10^{-3} \text{ Wb.}$$

Value of flux when the fluxmeter shows full scale deflection

$$= \frac{0.15 \times 10^{-3} \times 120}{1} = 18 \times 10^{-3} \text{ Wb.}$$

$$\text{Ratio } \frac{\text{flux to be measured}}{\text{flux for full scale deflection}} = \frac{66.7 \times 10^{-3}}{180 \times 10^{-3}} = 3.7$$

$$\text{Thus we have } \frac{R_c + R_s}{R_s} = \frac{0.025 + R_s}{R_s} = 3.7 \quad \text{or resistance of shunt } R_s = 0.00926 \Omega.$$

7.25. Vibration Galvanometers

Introduction. These galvanometers are of d'Arsonval type having a moving coil suspended between the pieces of a permanent magnet. When an alternating current is passed through the moving coil, an alternating deflection torque is produced which makes the coil vibrate with a frequency equal to the frequency of the current passing. On account of inertia of the moving parts, the amplitude of vibrations is small. However, if the natural frequency of the moving system is made equal to the frequency of the current, mechanical resonance is obtained and the moving system vibrates with a large amplitude.

The damping is very small in these galvanometers. This is required in order to obtain a sharp resonance curve so that the galvanometer is selective *i.e.*, it gives a very small deflection for alternating currents of frequencies other than the resonant frequency.

Vibration galvanometers are suitable for use at power and low audio frequencies, but they are mainly used at power frequencies. They can be manufactured for fixed frequencies, or they can be provided with tuning devices to cover a range of frequencies.

Construction. Fig. 7.20 shows the construction of a Duddell's moving coil vibration galvanometer. The moving coil consists of a fine bronze or platinum silver wire. This wire passes over a small pulley at top the and is pulled tight by a spring attached to the pulley, the tension of the spring can be adjusted by turning a milled head attached to the spring. The loop of wire is stretched over two ivory bridge pieces, the distance between these pieces is adjustable. When the moving coil vibrates due to passage of a.c., the reflected beam from the mirror throws a band of light upon a scale provided for the purpose.

Tuning. Tuning means adjustment of the natural frequency of the moving system so that it is equal to the frequency of the current passing through the coil.

In the case of Duddell's galvanometer coarse tuning is done by varying the distance between the bridge pieces. This varies the length of the loop which is free to vibrate and thus varies the natural frequency of the moving system. Fine adjustment of tuning is done by varying the tension of the spring.

When the galvanometer is tuned (*i.e.* when it is under mechanical resonance conditions), the amplitude of vibrations is very large and consequently a very wide band of light is observed on the scale.

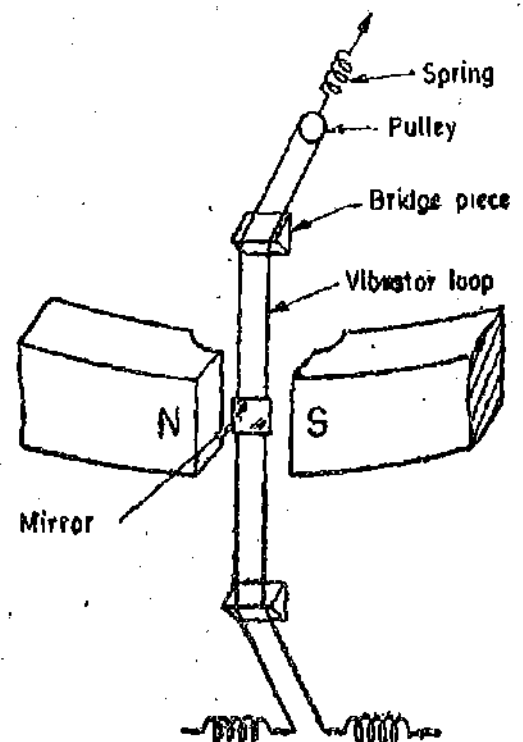

Fig. 7.20. Vibration galvanometer.

Theory. Let the value of current passing through the moving coil at an instant t be :

$$i = I_m \sin \omega t \quad \therefore \text{Deflecting torque } T_d = Gi = GI_m \sin \omega t.$$

Equation of motion is $T_i + T_b + T_c = T_d$

or
$$J \frac{d^2\theta}{dt^2} + D \frac{d\theta}{dt} + K\theta = GI_m \sin \omega t.$$

Complementary Function. The galvanometer is underdamped and therefore the complementary function is given

$$\theta = e^{-\frac{D}{2J}t} F \left[\sin(\omega t + \phi) \right] \quad (\text{See Eqn. 7.17})$$

Particular Integral

Writing the equation for motion we have : $J \frac{d^2\theta}{dt^2} + D \frac{d\theta}{dt} + K\theta = GI_m \sin \omega t.$

The particular integral is of the form $\theta = A \sin(\omega t - \alpha)$ where A and α are constants.

We have, $\frac{d\theta}{dt} = A\omega (\cos \omega t - \alpha)$ and $\frac{d^2\theta}{dt^2} = -A\omega^2 \sin(\omega t - \alpha)$

Substituting the above values in equation for motion, we have

$$-AJ\omega^2 \sin(\omega t - \alpha) + AD\omega \cos(\omega t - \alpha) + AK \sin(\omega t - \alpha) = GI_m \sin \omega t$$

The above relation must hold good for all values of t .

When $\omega t - \alpha = 0$, $AD\omega = GI_m \sin \alpha$... (i)

When $(\omega t - \alpha) = \pi/2$, $-AJ\omega^2 + AK = GI_m \cos \alpha$... (ii)

Squaring (i) and (ii) and adding we get : $A^2 D^2 \omega^2 + A^2 (K - J\omega^2)^2 = G^2 I_m^2$

or
$$A = \frac{GI_m}{\sqrt{(D\omega)^2 + (K - J\omega^2)^2}}$$

Also from (i) and (ii) $\tan \alpha = \frac{D\omega}{K - J\omega^2}$ or $\alpha = \tan^{-1} \frac{D\omega}{K - J\omega^2}$.

\therefore Particular integral is, $\theta = \frac{GI_m}{\sqrt{(D\omega)^2 + (K - J\omega^2)^2}} \sin(\omega t - \alpha).$

Hence the complete solution is

$$\theta = e^{-\frac{D}{2J}t} F \left[\sin(\omega t + \phi) \right] + \frac{GI_m}{\sqrt{(D\omega)^2 + (K - J\omega^2)^2}} \sin(\omega t - \alpha) \quad \dots(7.131)$$

The first term on the right hand side of Eqn. 7.131 is a transient term and effects only the deflection for a first few vibrations after switching on and therefore it is of little importance.

Hence deflection,
$$\theta = \frac{GI_m}{\sqrt{(D\omega)^2 + (K - J\omega^2)^2}} \sin(\omega t - \alpha) \quad \dots(7.132)$$

The amplitude of vibrations is
$$A = \frac{GI_m}{\sqrt{(D\omega)^2 + (K - J\omega^2)^2}} \quad \dots(7.133)$$

Now we should make the amplitude as large as possible. For a particular value of current I_m the amplitude can be made large by increasing G or by decreasing $(D\omega)^2 + (K - J\omega^2)^2$.

1. **Increasing G .** Since $G = NBA$, it may be made large by using a coil of large area A and having large number of turns N . But increasing the area and the number of turns, the inertia constant J is increased and therefore the term $(D\omega)^2 + (K - J\omega^2)^2$ also increases. Hence the purpose is not served. G can be made large by using a high value of flux density B . Therefore, powerful magnets are used in vibration galvanometers to give large amplitude of vibrations, i.e., to increase their sensitivity.

2. **Decreasing $(D\omega)^2 + (K - J\omega^2)^2$.** There are three constants involved J , D and K . If we consider an existing galvanometer, J and D are fixed and only control constant K can be changed. The control constant K can be varied by adjusting the length and tension of the suspension of the moving system.

In order that the amplitude be maximum, the term $(D\omega)^2 + (K - J\omega^2)^2$ should be minimum. This requires that

$$K - J\omega^2 = 0$$

or
$$\omega = \sqrt{K/J} \quad \text{or supply frequency } f = \frac{\omega}{2\pi} = \frac{1}{2\pi} \sqrt{\frac{K}{J}}$$

But $\frac{1}{2\pi} \sqrt{\frac{K}{J}}$ is the natural undamped frequency, f_n of the moving system.

\therefore For maximum amplitude $f = f_n$.

Thus the vibration galvanometer is tuned by changing the length and tension of the moving system in order that the natural frequency of moving system is equal to the supply frequency.

The deflections at various frequencies can be calculated from Eqn. 7.133, and the results plotted as shown in Fig. 7.21. It is found that for a galvanometer having a sharply peaked resonance curve a slight deviation from the resonant frequency results in a large reduction in deflection. Therefore, the galvanometer responds to only fundamental frequency (frequency for which it is tuned) and the harmonics have no appreciable effect upon the deflection.

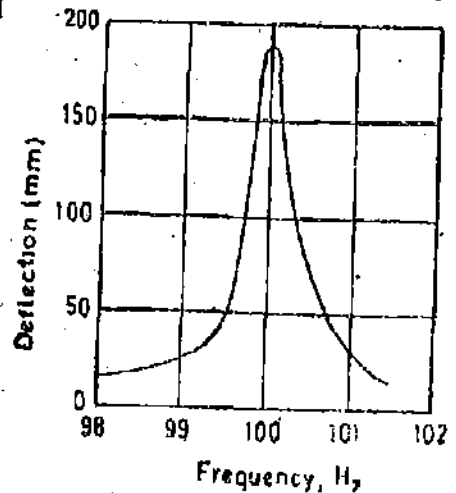

Fig. 7.21. Deflections of a vibration galvanometer at different frequencies.

Vibration galvanometers can be used for frequencies between 100 to 1800 Hz. The current sensitivity is about 50 mm/ μ A with a scale 1 metre away. The sensitivity is almost inversely proportional to the frequency.

Example. 7.27. Calculate the ratio of sensitivity for fundamental to that for third harmonic for a vibration galvanometer tuned to a frequency of 50 Hz. The data of the galvanometer is :

Inertia constant = 10×10^{-3} kg-m² ; damping constant = 25×10^{-3} N-m/rad-s⁻¹.

Solution : From Eqn. 7.133 the amplitude of vibration of a frequency ω is :

$$A = \frac{GI_m}{\sqrt{(D\omega)^2 + (K - J\omega^2)^2}}$$

Therefore the ratio of amplitudes of fundamental and third harmonic is :

$$\frac{A_1}{A_3} = \frac{\sqrt{(3D\omega_1)^2 + (K - 9J\omega_1^2)^2}}{\sqrt{(D\omega_1)^2 + (K - J\omega_1^2)^2}}$$

For a tuned galvanometer $\omega_1 = \sqrt{\frac{K}{J}}$ or $K = J\omega_1^2$.

Thus we have

$$\frac{A_1}{A_3} = \frac{\sqrt{(3D\omega_1)^2 - (J\omega_1^2 - 9J\omega_1^2)^2}}{D\omega_1} = \frac{\sqrt{(3D\omega_1)^2 + (8J\omega_1^2)^2}}{D\omega_1}$$

$$= \frac{\sqrt{(3 \times 25 \times 10^{-3} \times 2\pi \times 50)^2 + (8 \times 10 \times 10^{-3} \times 4\pi^2 \times 50^2)^2}}{25 \times 10^{-3} \times 2\pi \times 50} \approx 1000$$

From above it is clear that for a tuned galvanometer the deflection caused by the harmonics will be insignificant as compared to that for the fundamental.

7.26. Duddell's Oscillograph

Construction. It consists of a single loop of thin phosphor-bronze strip which forms the moving system. It is called a vibrator loop. The vibrator loop is situated in the field of a permanent magnet but when high sensitivities are required, highly saturated electromagnets are used.

The vibrator loop (Fig. 7.22) is formed by passing the strip over an ivory pulley. A spring tension adjusting device is attached to the ivory pulley. A small mirror for reflecting light is cemented to the loop midway between the bridge pieces.

A Duddell element is essentially a vibration galvanometer having a low period of vibrations. The natural frequency is about 10 kHz. The loop is immersed in oil to get a high degree of damping.

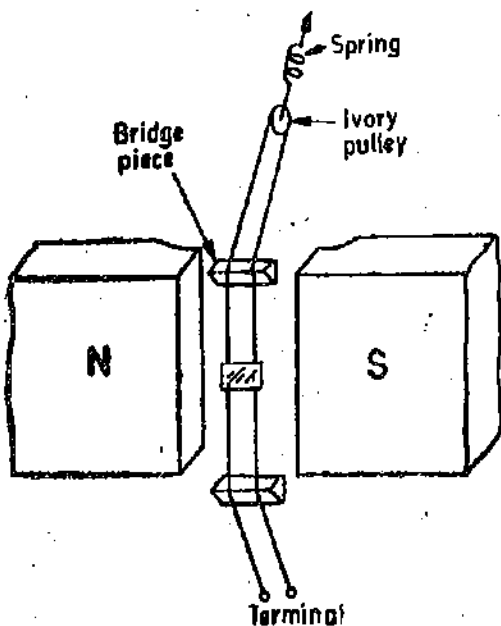

Fig. 7.22. Duddell's Oscillograph element.

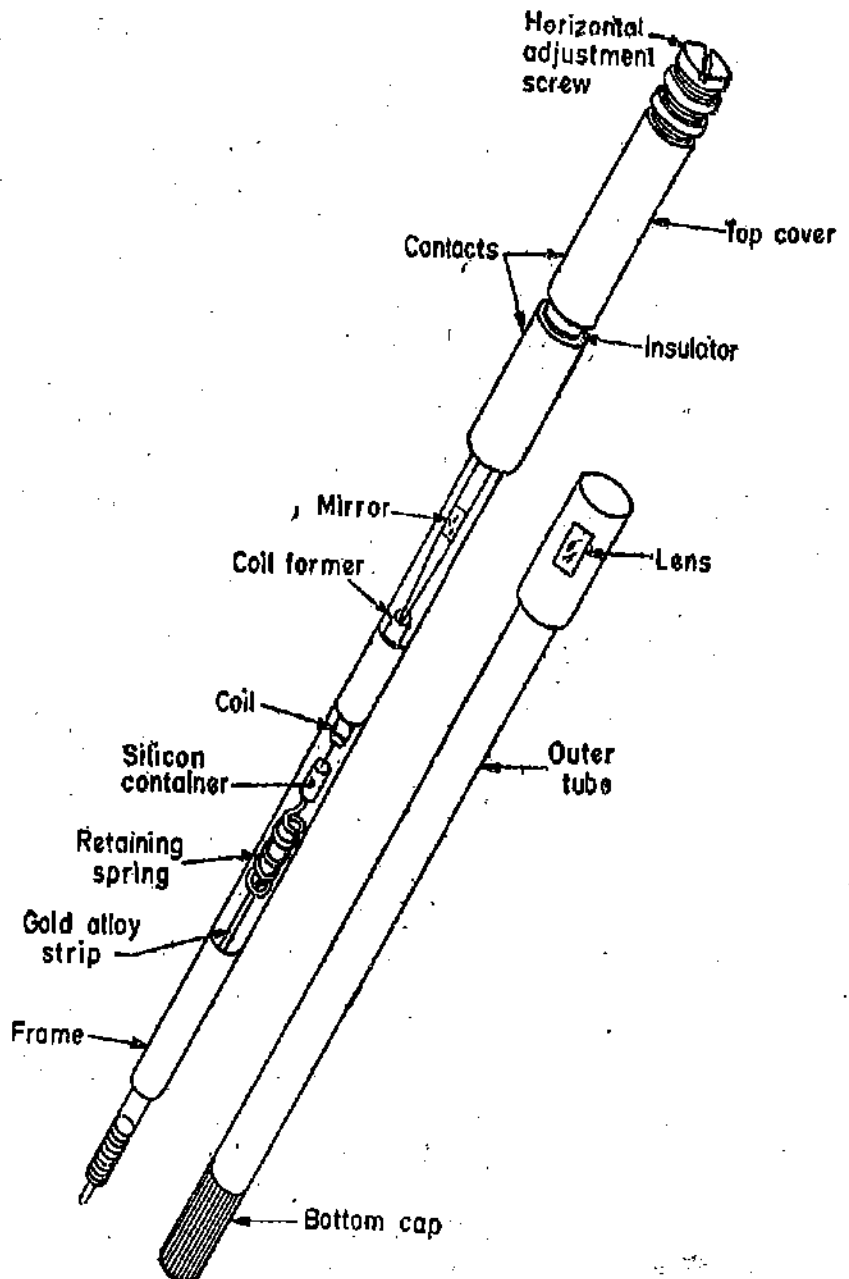

Fig. 7.23. Recorder Pencil Galvanometer.

The galvanometer units can be constructed with diameters 3 mm to 6 mm and about 75 mm length. A typical unit is shown in Fig. 7.23. These galvanometer units are often called pencil galvanometers. They comprise the moving element of the galvanometer and are set in a fixed frame of the permanent magnets. Two or more units per cm can be constructed and 50 or more galvanometers are included in a single oscillograph in order to record many waveforms simultaneously.

Operation. When an alternating current is passed through the loop, an alternating torque acts upon the loop and it vibrates. When a beam of light is cast upon the mirror, it is reflected. As the loop is vibrating, the reflected beam will move backwards and forwards. If a wave shape is to be recorded, a photographic film is passed at a constant speed in a direction perpendicular to that of the movement of the reflected beam of light. The actual speed of film depends upon the frequency of the wave being recorded.

The wave shape is recorded on the film as a result of the two perpendicular motions, i.e., of the film and the reflected light. The oscillograph is calibrated by passing a known value of direct current in the loop and recording the deflection produced by the current.

If the waveform is not to be recorded but is only to be observed, the arrangement as shown in Fig 7.24 is used. The reflected beam of light from the vibrator mirror falls on a plane mirror and is further reflected on to a screen. The plane mirror is rocked by a cam driven by a synchronous motor. The synchronous motor is supplied from the source whose waveform is to be observed. The plane mirror driven by the cam, gives forward motion of the reflected beam on the screen. The forward motion is carried out for $1\frac{1}{2}$ cycles of the wave, and the plane mirror is returned to its original position during the next half cycle. During this cycle the light is cut off by a rotating shutter. The process is repeated continuously and the wave shape appears stationary on the screen on account of persistence of vision.

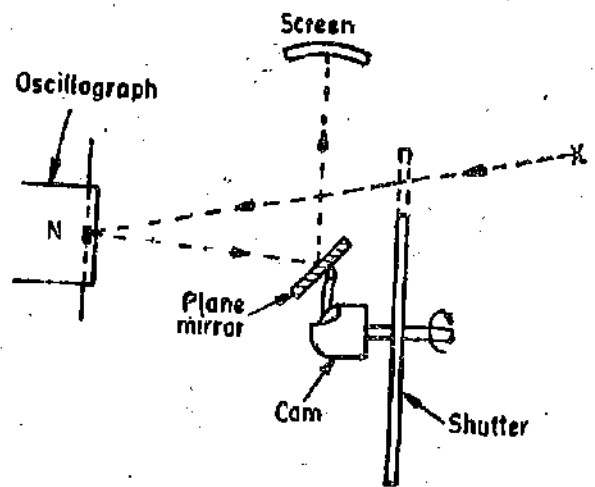

Fig. 7.24. Observation of waveform with Duddell's oscilloscope.

Uses. (i) These oscillographs are particularly suited at low voltages and low frequencies.

(ii) These oscillographs may be provided with a larger number of elements and therefore a number of quantities may be observed or recorded simultaneously.

(iii) They afford convenient facilities for photographic purposes.

Disadvantages. (i) The use of these oscillographs is limited to frequencies upto 500 Hz if an accurate record of the waveform is required. Above this frequency the response to higher order harmonics is very small and therefore the harmonics are not recorded.

(ii) The use of these instruments is more complicated.

These oscillographs are not commonly used these days and for many purposes they have been replaced by the cathode ray oscillographs.

Theory. Duddell's oscillograph is essentially a vibration galvanometer, and therefore its equation of motion is :

$$J \frac{d^2\theta}{dt^2} + D \frac{d\theta}{dt} + K\theta = Gi$$

When considering a vibration galvanometer the current i was assumed to be purely sinusoidal, its equation being $i = I_m \sin \omega t$.

However, in the case of an oscillograph, this assumption cannot be made since oscillograph is used for determination of wave forms of non-sinusoidal quantities. Therefore, current i in the case of an oscillograph contains harmonics and it may be written as :

$$i = \sum_{n=1}^{n=\infty} I_{m_n} \sin(n\omega t + \phi_n) \quad \dots(7'134)$$

according to Fourier's theorem where n is the order of the harmonic.

When dealing with the vibration galvanometer, the equation for deflection θ was found to contain a transient term and a term corresponding to steady vibration motion (See Eqn. 7'131). In a Duddell's oscillograph critical or nearly critical damping is provided and therefore the transient term decays after a very small interval of time and can thus be neglected.

The expression for deflection in a vibration galvanometer is

$$\theta = \frac{GI_m}{\sqrt{(D\omega)^2 + (K - J\omega^2)^2}} (\sin \omega t - \alpha) \quad \text{(See Eqn. 7'132)}$$

Therefore for a Duddell's oscillograph: $\theta = G \sum_{n=1}^{n=\infty} \frac{I_{m_n} \sin(n\omega t + \phi_n - \alpha_n)}{\sqrt{(Dn\omega)^2 + (K - Jn^2\omega^2)^2}}$... (7'135)

where $\alpha_n = \tan^{-1} \frac{Dn\omega}{K - Jn^2\omega^2}$... (7'136)

The amplitude of deflection corresponding to n th harmonic

$$\theta_n = \frac{GI_{m_n}}{\sqrt{(Dn\omega)^2 + (K - Jn^2\omega^2)^2}} \quad \dots(7'137)$$

$$= \frac{GI_{m_n}/K}{\sqrt{(Dn\omega/K)^2 + (1 - Jn^2\omega^2/K)^2}} \quad \dots(7'138)$$

But $\frac{D}{K} = \frac{2D}{2\sqrt{KJ}} \cdot \sqrt{\frac{J}{K}} = \frac{2\zeta}{\omega_n}$ as $\frac{D}{2\sqrt{KJ}} = \zeta$ and $\sqrt{\frac{J}{K}} = \frac{1}{\omega_n}$ and $J/K = 1/\omega_n^2$

Substituting the above values in Eqn. 7'138, we have :

$$\theta_n = \frac{GI_{m_n}/K}{\sqrt{1 - n^2\omega^2/\omega_n^2)^2 + (2\zeta n\omega/\omega_n)^2}} \quad \dots(7'139)$$

But the deflection under ideal (d.c.) conditions is $\theta_n' = \frac{GI_{m_n}}{K}$... (7'140)

$$\therefore \theta_n = \frac{\theta_n'}{\sqrt{(1 - n^2\omega^2/\omega_n^2)^2 + (2\zeta n\omega/\omega_n)^2}} \quad \dots(7'141)$$

Hence, ratio of actual amplitude to ideal amplitude

$$\frac{\theta_n}{\theta_n'} = \frac{1}{\sqrt{(1 - n^2\omega^2/\omega_n^2)^2 + (2\zeta n\omega/\omega_n)^2}} \quad \dots(7'142)$$

$$= \frac{1}{\sqrt{(1 - u^2)^2 + (2\zeta u)^2}} \quad \dots(7'143)$$

where $u = \text{frequency ratio} = n\omega/\omega_n$ (7'144)

It is clear from Eqn. 7'143 that the amount of damping used is of vital importance. If the galvanometer is overdamped, the amplitude will decrease as the frequency is increased while an underdamped galvanometer will produce excessive deflections for frequencies near the natural or resonant frequency. Hence a compromise must be made. The curves for deflection amplitude ratio (θ_n/θ_n') against frequency ratio ($n\omega/\omega_n$) are shown in Fig. 7'25 for various values of damping ratio, ζ . It shows that if damping ratio $\zeta = 0.64$ is used, the deflection amplitude is within ± 5 per cent of ideal amplitude for frequencies upto 60 per cent of galvanometer resonant frequency.

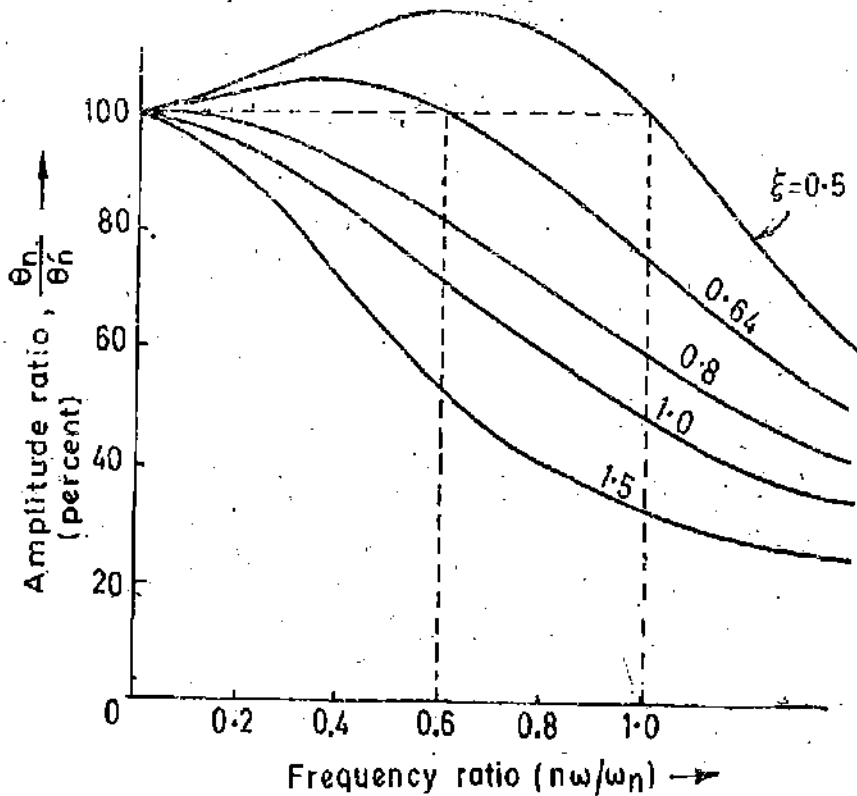

Fig. 7.25. Amplitude V/s frequency ratio characteristics.

In addition to amplitude characteristics described above some phase shift, equivalent to a time delay, must inevitably occur between the input and the output on account of inertia and damping.

Let us examine the expression for phase shift

$$\alpha_n = \tan^{-1} \frac{Dn\omega}{K - Jn^2\omega^2} = \tan^{-1} \frac{n\omega D/K}{1 - n^2\omega^2 J/K} = \tan^{-1} \frac{2\xi n\omega/\omega_n}{1 - n^2\omega^2/\omega_n^2} = \tan^{-1} \frac{2\xi u}{1 - u^2} \quad \dots(7.145)$$

It is clear from Eqn. 7.145 that the harmonics in the output waveshape do not have the same relative phases as those in the input current waveshape as the value of α_n will be different for different harmonics. Hence the oscillograph does not give a true reproduction of current wave. However, it can be made to give a reproduction which is sufficiently accurate for practical purposes.

Eqn. 7.145 gives the phase displacement of the output frequency with respect to its true position, measured on its own time scale of angular frequency. In order to estimate the distortion produced in the output wave, it is necessary to calculate the phase displacement of fundamental and each harmonic and to allow for the different angular frequency scales of the various harmonics. For example, a 35° phase shift for 7th harmonic on its own time scale represents $35/7 = 5^\circ$ displacement on the angular frequency scale of the fundamental.

Thus it is clear from above that the phase shift can be made to have negligible importance provided that it can be made directly proportional to frequency that is all frequencies of input waveform are delayed by the same time interval.

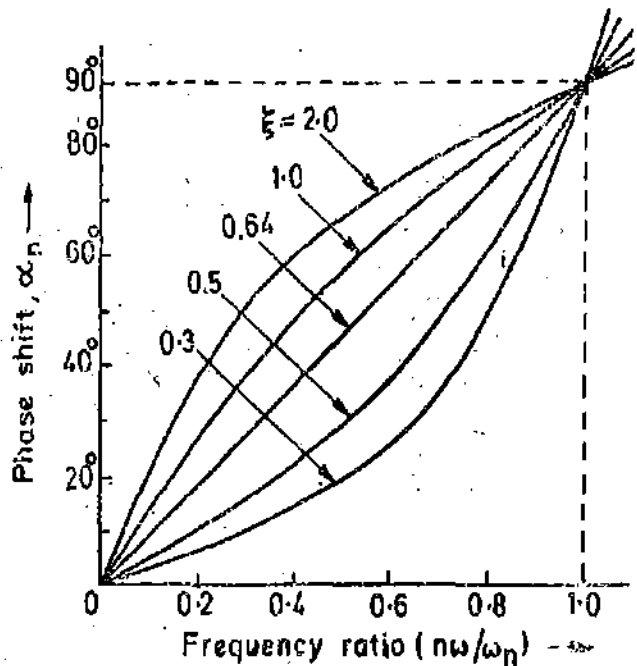

Fig. 7.26. Phase shift V/s frequency ratio characteristic.

Fig. 7.26 shows the curves of phase shift against frequency ratio for different values of damping constant ζ . It is clear that the relationship is linear for $\zeta=0.64$.

Fortunately the optimum amplitude performance is also obtained with $\zeta=0.64$.

Critically Damped Oscillograph. When the galvanometer is critically damped $\zeta=1$. The ratio of actual amplitude to ideal amplitude is given by substituting $\zeta=1$ in Eqn. 7.143

$$\frac{\theta_n}{\theta_n'} = \frac{1}{\sqrt{(1-u^2)^2 + (2 \times 1 \times u)^2}} = \frac{1}{1+u^2} \quad \dots(7.146)$$

$$= \frac{1}{1+n^2\omega^2/\omega_n^2} \quad \dots(7.147)$$

Suppose T_0 is the period of natural oscillations and T is the period of fundamental.

$$\therefore \text{From Eqn. 7.147 we get } R_n = \frac{\theta_n}{\theta_n'} = \frac{1}{1+n^2T_0^2/T^2} = \frac{1}{1+n^2(T_0/T)^2} \quad \dots(7.148)$$

$$\text{Phase angle } \alpha_n = \tan^{-1} \frac{2\zeta u}{1-u^2}$$

$$\text{For critically damped oscillograph } \alpha_n = \tan^{-1} \frac{2u}{1-u^2} = \tan^{-1} \frac{2n\omega/\omega_n}{1-n^2\omega^2/\omega_n^2} \quad \dots(7.149)$$

$$= \tan^{-1} \frac{2n}{(T/T_0) - (n^2T_0/T)} \quad \dots(7.150)$$

For ideal oscillograph $J=0$ and $D=0$ $\therefore \alpha_n=0$

Example 7.28. The relative damping in a Duddell's oscillograph is 0.6. The natural frequency is 2400 Hz, calculate the range of frequencies over which the oscillograph will have an amplitude distortion of less than $\pm 2\%$.

Solution. The ratio of actual amplitude to ideal amplitude is :

$$\frac{\theta_n}{\theta_n'} = \frac{1}{\sqrt{(1-u^2)^2 + (2\zeta u)^2}} \quad (\text{See Eqn. 7.143})$$

In order that amplitude distortion be less than ± 2 per cent, the value of θ_n/θ_n' should be between 0.98 and 1.02.

$$\therefore 0.98 = \frac{1}{\sqrt{(1-u^2)^2 + (2 \times 0.6u)^2}} \quad \text{or } u=0.79$$

Hence upper frequency $= 0.79 \times 2400 = 1826$ Hz

$$\text{For amplitude be upto } +2\%. \quad 1.02 = \frac{1}{\sqrt{(1-u^2)^2 + (2 \times 0.6u)^2}} \quad \text{or } u=0.29$$

Lower frequency $= 0.29 \times 2400 = 696$ Hz.

Hence the range of frequencies between which the amplitude distortion is within $\pm 2\%$ is 696 Hz to 1826 Hz.

Example 7.29. An oscillograph has a natural frequency of 500 Hz and a damping ratio of 0.64. The fundamental frequency applied to it is 50 Hz. Calculate the phase displacement for the fundamental and 5th harmonic. Calculate the error in recording time of the 5th harmonic with regards to fundamental. Supposing the speed of the photographic paper is 2.5 m/s, calculate the displacement in mm.

Solution. The phase displacement is given by :

$$\alpha_n = \tan^{-1} \frac{2\zeta u}{1-u^2} \quad (\text{Eqn. 7.145})$$

For fundamental $u = 50/500 = 0.1$

∴ Phase displacement of fundamental $\alpha_1 = \tan^{-1} \frac{2 \times 0.64 \times 0.1}{1 - (0.1)^2} = 7.366^\circ = 7^\circ 22'$ (C)

For fifth harmonic $u = 5 \times 50/500 = 0.5$

Phase displacement for fifth harmonic $\alpha_5 = \tan^{-1} \frac{2 \times 0.64 \times 0.5}{1 - (0.5)^2} = 40.47^\circ = 40^\circ 28'$ (E)

Phase displacement of 5th harmonic on fundamental scale

$$\alpha_5 = \frac{40^\circ 28'}{5} = 8^\circ 5'6''$$

Time lag for fundamental $= \frac{7.366}{360 \times 50} = 0.409 \times 10^{-3} \text{ s.}$

The time for a complete cycle is $1/50 \text{ s} = 409 \text{ } \mu\text{s.}$

Time lag for 5th harmonic $= \frac{40.47}{360 \times 5 \times 50} = 0.45 \times 10^{-3} \text{ s} = 450 \text{ } \mu\text{s.}$

Error in recording time $= 450 - 409 = 41 \text{ } \mu\text{s.}$

Error in mm = speed \times time $= 2.5 \times 41 \times 10^{-6} \approx 0.1 \times 10^{-3} \text{ m} = 0.1 \text{ mm.}$

Example 7.30. A Duddell's oscillograph has a moving system whose natural period of oscillation is $1/2000$ second. The oscillograph is critically damped. The wave-form of a complex wave, the frequency of whose fundamental is 50 Hz is to be determined. What are the percentage errors in the production of 3rd, 5th, 7th, 11th and 13th harmonics? Also determine the phase displacement of 13th harmonic.

Solution. We have: $T_0 = 1/2000 \text{ s, and } T = 1/50 \text{ s}$

We have $R_n = \frac{1}{1 + n^2(T_0/T)^2}$

Therefore $R_1 = \frac{1}{1 + (1)^2(50/2000)^2} = 0.9994$

$$R_3 = \frac{1}{1 + (3)^2(50/2000)^2} = 0.9944$$

$$R_5 = \frac{1}{1 + (5)^2(50/2000)^2} = 0.9844$$

$$R_7 = \frac{1}{1 + (7)^2(50/2000)^2} = 0.9694$$

$$R_{11} = \frac{1}{1 + (11)^2(50/2000)^2} = 0.9244$$

$$R_{13} = \frac{1}{1 + (13)^2(50/2000)^2} = 0.9044$$

Thus the percentage errors in reproduction are :

In 3rd harmonic -0.36 percent

In 5th harmonic -1.56 percent

In 7th harmonic -3.06 percent

In 11th harmonic -7.56 percent

In 13th harmonic -9.56 percent.

Displacement of n th harmonic $\alpha = \tan^{-1} \frac{2n}{(T/T_0) - n^2(T_0/T)}$ (See Eqn. 7.156)

Phase displacement of 13th harmonic $\alpha_{13} = \tan^{-1} \frac{2 \times 13}{(2000/50) - (13)^2(50/2000)} = 36^\circ 0'$

Phase displacement of fundamental $\alpha_1 = \tan^{-1} \frac{2 \times 1}{(2000/50) - (1)^2(50/2000)} = 2^\circ 52'$

On 13th harmonic scale $2^\circ 52'$ is equivalent to $13 \times 2^\circ 52' = 37^\circ 16'$.

\therefore 13th harmonic is shown $37^\circ 16' - 36^\circ 0' = 1^\circ 16'$ ahead of its true position.

UNSOLVED PROBLEMS

1. Find the steady state deflection of a moving coil galvanometer in degrees and in mm on a scale placed 1 m away when a current of 1 mA is passed through its coil. Also calculate the resistance required for critical damping if the galvanometer has a relative damping of 0.1 on open circuit. The data of the galvanometer is :

Dimensions of coil = 25×20 mm, number of turns = 100, flux density = 0.1 Wb/m², inertia constant = 0.1×10^{-6} kg-m² and control constant = 25×10^{-4} Nm/rad.

Hint : Resistance required for critical damping = $\frac{G^2}{2\sqrt{KJ(1-0.1)}}$

[Ans. 11.45° , 400 mm, 6.2Ω]

2. A moving coil galvanometer gives a deflection of 100 mm on a scale 2 m away from its mirror with a current of $1 \mu\text{A}$. When swinging freely on open circuit, the time of one complete oscillation is 3 second. The galvanometer is dead beat when the total resistance of the circuit is 2800Ω . Find the moment of inertia of the moving system.

[Ans. 0.972×10^{-6} kg-m²]

3. The constants of a galvanometer are :

Control constant = 0.23×10^{-6} N-m/rad;

Damping constant = 5×10^{-9} N-m/rad-s⁻¹,

Moment of inertia = 0.18×10^{-6} kg-m².

It is proposed to increase the periodic time to 15 second by attaching small weights on light arms fixed to the coil spindle. Determine by how much these weights must increase the moment of inertia of the coil.

[Ans. 1.13×10^{-6} kg-m²]

4. In a moving coil instrument, critical damping is to be provided only by eddy currents in the aluminium former carrying the moving coil. The moment of inertia of moving system is 3×10^{-9} kg-m². The torsional constant of the control spring is 2×10^{-6} Nm/rad and the loop resistance of aluminium former 0.006 ohm. Calculate the required coil flux linkages per radian deflection.

[Ans. 30.3×10^{-9} Wb/rad]

5. A moving coil galvanometer has a coil wound upon a former of non-conducting material. The current sensitivity of the instrument is $0.001 \mu\text{A/mm}$ at 1 m and the undamped periodic time is 5 s. If the torque is 0.0632 N-m/A, calculate the control torque of the suspension, the moment of inertia of moving system and the total circuit resistance which critically damps the instrument. The effect of air damping may be neglected.

[Ans. 0.1264×10^{-6} N-m/rad, 25.2×10^{-6} kg-m², 1125Ω]

6. A d'Arsonval galvanometer has the following data :

Flux density = 8×10^{-3} Wb/m², number of turns = 300, length of coil = 15 mm, width of coil = 30 mm, spring constant = 2.5×10^{-7} Nm/rad, moment of inertia = 10×10^{-9} kg-m², damping constant = 2×10^{-9} Nm/rad-s⁻¹, resistance of coil = 80Ω . Calculate (a) the deflection of galvanometer for a current of $1 \mu\text{A}$, (b) current sensitivity in mm/ μA if the scale is kept 1 m away from the mirror.

Prove that the galvanometer is underdamped. Find (c) the natural frequency of oscillations (d) relative damping (e) frequency of damped oscillations (f) first maximum deflection (g) external resistance required for critical damping. [Ans. (a) 0.432 rad (b) 864 mm/ μA (c) 0.5 rad/s (d) 0.2 (e) 0.49 rad/s (f) 0.66 rad (g) 36.7Ω]

7. The torsional constant of a galvanometer is 5×10^{-9} Nm/rad. Calculate the energy stored in the suspension when it has been twisted through 0.4 rad.

The moment of inertia of the coil is 0.2×10^{-4} kg-m². Calculate the angular velocity which the coil will have when it passes through its equilibrium position if damping is neglected.

[Hint : Kinetic energy = $\frac{1}{2} J \omega^2_{max} = \frac{1}{2} K \theta^2_{max}$]

[Ans. 2 rad/s]

8. Fig. 7.10 shows a circuit for testing of a galvanometer where $E = 1.5$ V, $R_1 = 1.0 \Omega$, $R_2 = 2500 \Omega$, R_3 is variable.

When $R_g=450 \Omega$, the galvanometer deflection is 1500 mm and, with $R_g=950 \Omega$, the deflection is reduced to 75 mm. Calculate (a) the resistance of galvanometer, (b) current sensitivity of galvanometer.
[Ans. (a) 49Ω , (b) $125 \text{ mm}/\mu\text{A}$]

9. A ballistic galvanometer gives a first swing of 60° for a discharge of $1000 \mu\text{C}$. Find the quantity of electricity to produce (a) a swing of 90° in the instrument (b) a spot deflection of 20 mm on a scale 1 m away.
[Ans. $1500 \mu\text{C}$; $19.1 \mu\text{C}$]

10. When a current of 0.001 A is passed through a ballistic galvanometer, it gives a steady deflection of 50 scale divisions. When a capacitor charged to a potential of 100 V d.c. is discharged through the galvanometer, it gives a maximum throw of 220 scale divisions. The periodic time of swing is 4 second. Find the value of capacitance.
[Ans. $28 \mu\text{F}$]

11. In an undamped galvanometer with a periodic time of 10 second, a current of 0.1 mA produces a steady deflection of 150 divisions. Find the instantaneous quantity of electricity to produce a first swing of 100 divisions. (a) when the instrument is undamped (b) when the instrument is damped so that its logarithmic decrement is 1.1.
[Ans. (a) $106 \mu\text{C}$ (b) $111 \mu\text{C}$]

12. The periodic time of an undamped ballistic galvanometer is 10 s and a current of 0.15 mA gives a steady deflection of 200 scale divisions. Find the quantity of electricity which can produce or swing of 120 scale divisions. What is the quantity of electricity corresponding to this swing if the instrument has a decrement of 1.03?
[Ans. $239 \mu\text{C}$ (undamped), $362 \mu\text{C}$ (damped)]

13. A ballistic galvanometer of resistance 1500Ω gives a throw of 75 divisions when the flux through the search coil to which it is connected, is reversed. If the flux density is $0.1 \text{ Wb}/\text{m}^2$, the search coil has 1400 turns, a mean area of 5500 m^2 and a resistance of 200Ω , calculate the galvanometer constant in terms of coulomb per scale division.
[Ans. $12 \mu\text{C}/\text{div.}$]

14. A ballistic galvanometer has an undamped free period of 8.7 s and a relative damping of 0.8. Determine the time required for the galvanometer to pass through zero after the application of charge.
[Ans. 7.3 s]

15. A Duddell's oscillograph has a moving system whose natural period of oscillation is 0.1 ms . The waveform of a complex wave, the frequency of whose fundamental is 50 Hz, is to be determined what are the percentage errors in reproduction of 3rd, 5th, 7th and 11th harmonics?
[Ans. 0.0225, 0.6024, 0.1224, 0.315]

16. A critically damped Duddell's oscillograph is required to reproduce the 13th harmonic of a 50 Hz wave with a relative amplitude correct to within 2 percent.

What should be the natural frequency of the movement? What will be the relative phase angle departure of the 13th harmonic?
[Ans. 4590 Hz; 16.7°]

Analog Ammeters, Voltmeters and Ohmmeters

8'1. Introduction. Analog ammeters and voltmeters are classed together as there are no fundamental differences in their operating principles. The action of all ammeters and voltmeters, with the exception of electrostatic type of instruments, depends upon a deflecting torque produced by an electric current. In an ammeter this torque is produced by current to be measured or by a definite fraction of it. In a voltmeter this torque is produced by a current which is proportional to the voltage to be measured. Thus all voltmeters and ammeters are essentially current measuring devices.

The essential requirements of a measuring instrument are (i) that its introduction into the circuit, where measurements are to be made, does not alter the circuit conditions; (ii) the power consumed by them for their operation is small.

Ammeters are connected in series in the circuit whose current is to be measured. Therefore, they should have a low electrical resistance. This is essential in order that they cause a small voltage drop and consequently absorb small power.

Voltmeters are connected in parallel with the circuit whose voltage is to be measured. They should have a high electrical resistance. This is essential in order that the current drawn by them is small and consequently the power absorbed is small.

"*Ohmmeters*" are used for measurement of resistance. They incorporate a source of emf and a current measuring device.

8'2. Power Loss. Let R_a be the resistance of the ammeter and I be the current being measured.

$$\text{Power loss in ammeter } P_a = I^2 R_a \text{ watt} \quad \dots(8'1)$$

If R_v be the resistance of the voltmeter and V be the voltage being measured,

$$\text{Power loss in voltmeter} = \frac{V^2}{R_v} \text{ watt.} \quad \dots(8'2)$$

Thus in order that the power loss in instruments is small, resistance of ammeters should be small and that of voltmeters should be large.

8'3. Types of instruments. The main types of instruments used as ammeters and voltmeters are :

- | | |
|---|-------------------|
| (i) Permanent magnet moving coil (PMMC) | (ii) Moving iron |
| (iii) Electro-dynamometer | (iv) Hot wire |
| (v) Thermocouple | (vi) Induction |
| (vii) Electrostatic | (viii) Rectifier. |

Of these the permanent-magnet moving-coil type can be used for direct-current measurements only, and the induction type for alternating-current measurement only. The other types can be used with either direct or alternating current.

The moving-iron and moving-coil types both depend for their action upon the magnetic effect of current. The former is the most generally used form of indicating instrument, as well as the cheapest. It can be used for either direct or alternating-current measurements and, if properly designed

is very accurate. The permanent-magnet moving-coil instrument is the most accurate type for direct-current measurements, and instruments of this type are frequently constructed to have substandard accuracy.

Electrodynamometer type of instruments are used both on a.c. as well as on d.c. Their calibration for both d.c. and a.c. is the same and hence they are very useful as "transfer instruments".

Thermal instruments have the advantage that their calibration is the same for both d.c. and a.c. They are particularly suited for alternating-current measurements since their deflection depends directly upon the heating effect of the alternating current, *i.e.* upon the rms value of the current. Their readings are thus independent of the frequency or wave-form of the current, and of any stray magnetic fields which may exist in their vicinity.

As voltmeters, electrostatic instruments have the advantage that their power consumption is exceedingly small. They can be made to cover a large range of voltage, and can be constructed to have substandard accuracy. Their main disadvantage is that the electrostatic principle is only directly applicable to voltage measurements.

The induction principle is more generally used for watt-hour meters than for ammeters and voltmeters owing to the comparatively high cost, and inaccuracy, of induction instruments of the latter types.

8.4. Errors in Ammeters and Voltmeters. There are certain errors which occur in most types of instruments, while other errors occur only in those of particular type. These latter errors will be dealt with later, together with the instruments in which they occur.

Of the errors common to most types of instruments, friction and temperature errors are perhaps the most important. To reduce the effect of friction torque, and consequently the error produced by it the weight of the moving system must be made as small as possible compared with the operating force, *i.e.* the ratio of torque to weight must be large (about 1/10 for full deflection).

A vertical spindle is generally preferred to a horizontal one from the point of view of a small friction torque.

The most serious error is produced by the heat generated in the instrument, or by changes in ambient (room) temperature, is that due to a change in the resistance of the working coil. Such a change of resistance is of little importance in ammeters, but in voltmeters, in which the working current should be directly proportional to the applied voltage, it is essential that the resistance of the instrument remains as nearly constant as possible.

Thus, the power loss in the instrument should be small, and resistance coils which are likely to produce appreciable heating should be mounted, if possible, in such a position that they are well ventilated. In order to eliminate temperature errors, the working coil is wound with copper wire and is of comparatively low resistance. A high "swamping" resistance of material whose resistance temperature coefficient is small, is connected in series with the coil, so that, although the resistance of the coil may change considerably, the change in total resistance is small.

Other errors resulting from heating may be caused by expansion of the control spring, or of other parts of the instrument, although such errors are usually small. Lack of balance in the moving system and changes in the strength of permanent magnets (if used) are other possible sources of error which are common to several types of instruments.

8.5. Permanent Magnet Moving Coil Instruments (PMMC)

The permanent magnet moving coil instrument is the most accurate type for d.c.

measurements. The working principle of these instruments is the same as that of the d'Arsonval type of galvanometer, the difference being that a direct reading instrument is provided with a pointer and a scale.

8'4. Construction The general constructional features of this instrument are shown in Fig. 8'1.

Moving Coil. The moving coil is wound with many turns of enamelled or silk covered copper wire. The coil is mounted on a rectangular aluminium former which is pivoted on jewelled bearings. The coil moves freely in the field of a permanent magnet. Most voltmeter coils are wound on metal frames to provide the required electro-magnetic damping. Most ammeter coils, however, are wound on non-magnetic formers, because coil turns are effectively shorted by the ammeter shunt. The coil itself, therefore, provides electro-magnetic damping.

Magnet Systems. There has been considerable development in materials for permanent magnets and, therefore, magnet assemblies have undergone a lot of change in the recent past. Old style magnet systems consisted of a relatively long U shaped permanent magnets having soft iron pole pieces. Owing to development of materials like Alcomax and Alnico, which have a high co-ercive force, it is possible to use smaller magnet lengths and high field intensities.

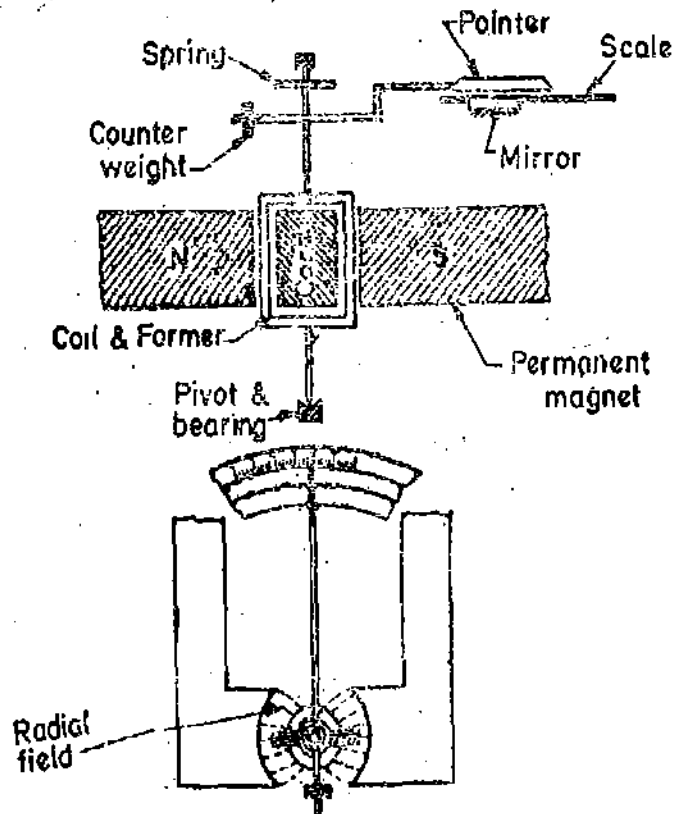

Fig. 8'1. Permanent magnet moving coil instrument.

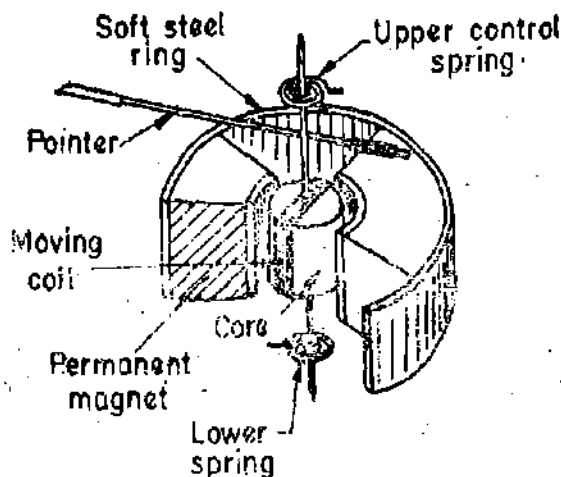

Fig. 8'2. Eccentric type magnet assembly.

concentric type it produces a radial flux pattern which extends over 250° or more. This type of construction is used for many panel type instruments and some portable instruments.

An air cored coil offset from the axis of rotation is used as shown in Fig. 8'3, the scale length of the instrument can be increased from 120° to 240° or even 300° thereby giving better resolution of reading for the same scale range.

In recent years, with the development of improved magnetic materials like Alnico, it has

Thus in small instruments it is possible to use a small coil having small number of turns and hence a reduction in volume is achieved. Alternatively in instruments having a large scale length it is possible to increase the air gap length to accommodate large number of turns.

The movement of the coil is restricted in the above design. This is because no actual part of the coil is allowed to reach the extreme positions near the pole tips where, there is fringing field. (Owing to fringing the flux density near the pole tips is smaller than that at the centre and also the field is not radial). Thus the angular span of scale is restricted to 90° . In order to obtain longer movement of the pointer and a longer angular swing of the coil a concentric magnet construction as shown in Fig. 8'2 is used. Since the magnet is

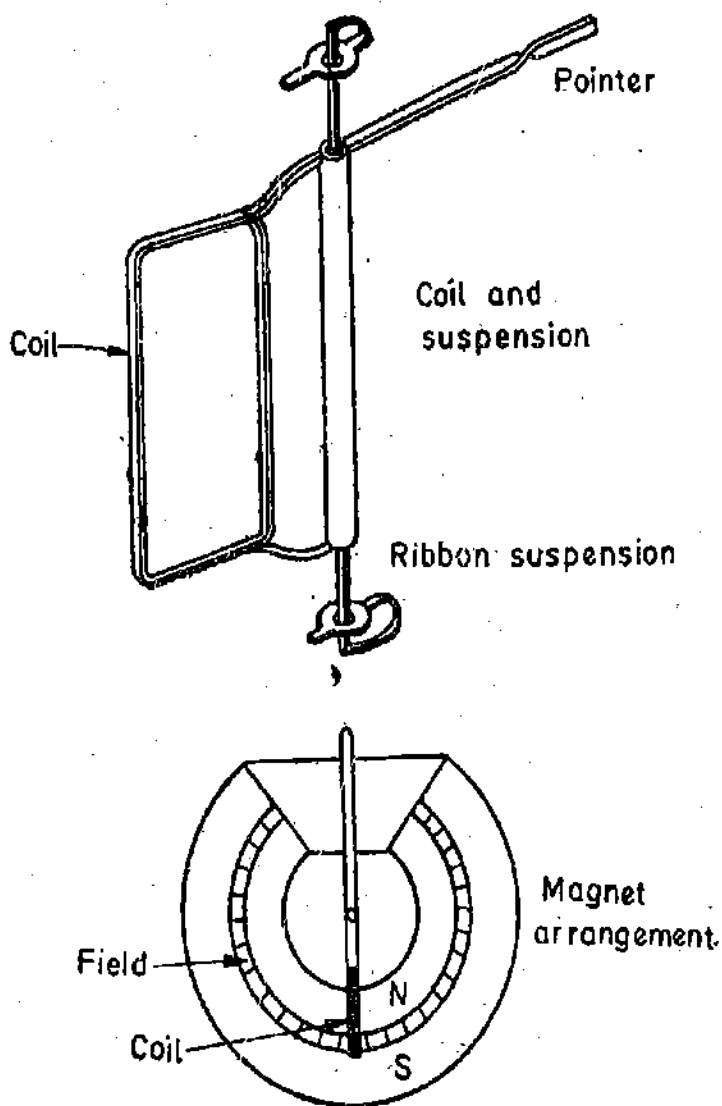

Fig. 8'3. Long scale moving coil instrument.

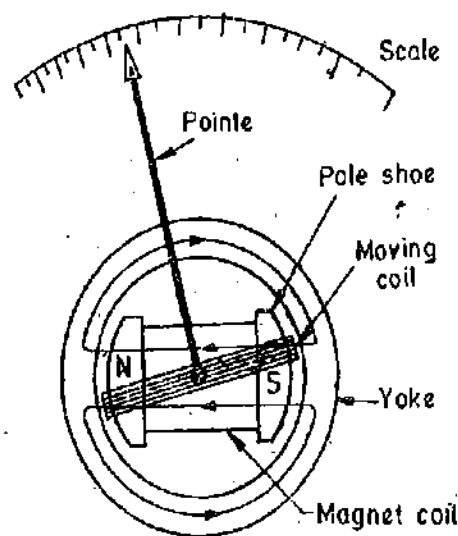

Fig. 8'4. Core magnet construction.

become feasible to design a magnetic system in which the magnet itself serves as the core as shown in Fig. 8'4. The moving coil moves over the magnet. The active sides of the moving coil are located in the uniform radial field between pole pieces and the steel yoke. This arrangements has the obvious advantage of being relatively unaffected by the external magnetic fields. It also eliminates the magnetic shunting effects in steel panel construction, where several meters operating side by side may affect each others' readings. The need for magnetic shielding in the form of iron cases, is also eliminated by core magnet construction.

Control. When the coil is supported between two jewel bearings the control torque is provided by two phosphor bronze hair springs. These springs also serve to lead current in and out of the coil. The control torque is provided by the ribbon suspension as shown in Fig. 8'3. This method is comparatively new and is claimed to be advantageous as it eliminates bearing friction.

Damping. Damping torque is produced by movement of the aluminium former moving in the magnetic field of the permanent magnet.

Pointer and Scale. The pointer is carried by the spindle and moves over a graduated scale. The pointer is of light-weight construction and, apart from those used in some inexpensive instruments, has the section over the scale twisted to form a fine blade. This helps to reduce parallax errors in the reading of the scale. In many instruments such errors may be reduced further by careful alignment of the pointer blade and its reflection in the mirror adjacent to scale. The weight

of the instrument is normally counter balanced by weights situated diametrically opposite and rigidly connected to it.

8.7. Torque Equation. The torque for a moving coil instrument is derived in Art. 7.4.

Deflection torque is $T_d = NB l d I = GI$... (8.3)

where $G = \text{a constant} = NB l d$... (8.4)

The spring control provides a restoring (controlling) torque $T_c = K\theta$... (8.5)

where $K = \text{spring constant.}$

For final steady deflection $T_c = T_d$ or $GI = K\theta$

\therefore Final steady deflection $\theta = \frac{G}{K} I$... (8.6)

or current $I = K_i \theta$... (8.7)

where $K_i = \frac{K}{G} = \text{a constant.}$... (8.8)

Shape of Scale. As the deflection is directly proportional to the current passing through the meter, we get a uniform (linear) scale for the instrument.

Non-linear Scales. The conventional permanent magnet moving coil mechanism uses a core and pole pieces having concentric faces. This means that the field is uniform and radial throughout the air gap. When the current being measured is directly passed through the meter, the instrument shows a uniform scale as shown in 'C' [See Fig. 8.5(a)].

Suppose now the current being measured is passed through a heater. The heat produced is proportional to I^2 . Let this heat actuate the meter somehow and, therefore, for such a mechanism deflection $\theta \propto I^2$. Thus the scale will show a square law distribution resulting from the use of a heating element with a standard moving coil mechanism. This distribution is shown in scale B.

The top scale A shows logarithmic distribution resulting when this moving coil mechanism is used for db measurements.

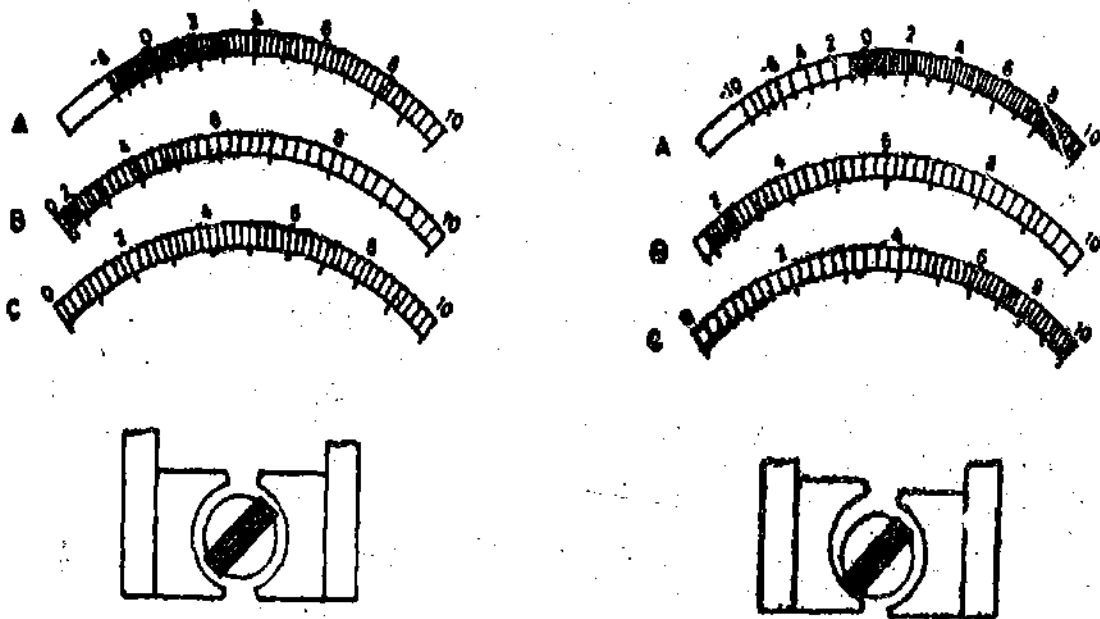

(a). Scales with uniform air gap. Fig. 8.5

(b). Scales with non-uniform air gaps.

Scales A and B are non-uniform and are cramped at the lower end. Because of cramping at the left, the upper two scales are difficult to read at the lower values.

Permanent magnet moving coil mechanisms may be supplied with specially shaped, or eccentric

pole pieces as shown in Fig. 8.5 (b). This results in an uneven flux distribution in the air gap and a non-linear relation between current in the moving coil and the deflection of the instrument.

This makes the scale non-uniform for conventional current measurements as shown in scale C, Fig. 8.5 (b). But it has the advantage that by properly shaping the pole faces, we can make the scale more linear for square law heating as shown in scale B.

In light and sound measurements, it is desirable to use a logarithmic scale. By properly shaping the pole faces, we can increase the scale range and make it more linear for such measurement. This is shown in scale A. It is evident, of course, that a logarithmic scale must start at some reading below zero.

The top db scale (scale A) is not only more uniform but also readable over a longer portion of arc. Such special poles and cores, though expensive to produce, are useful for making the permanent magnet moving coil mechanism adaptable to special applications.

It should be understood that we make the pole faces eccentric with core for only special applications. For conventional applications of current and voltage measurements the pole faces are concentric with the core.

8.8. Range.

D.C. Ammeter

- (1) Instrument alone, 0–5 μA to 0–20 mA. (2) With internal shunts, upto 0–200 A.
 (3) With external shunts, upto 0–5000 A.

D.C. Voltmeter

- (1) Instrument alone, 0–50 or 0–100 mV. (2) With series resistance upto 20,000 to 30,000 V.

In micro-ammeters and low range milli-ammeters upto about 20 mA, the entire current to be measured is sent through the moving coil. This is because instrument springs serve as current leads to the moving coil. Their current carrying capacity limits the current which can be safely carried to about 20 mA. For higher currents (usually above 20 mA) the moving coil is shunted to bypass current around the coil and the spring.

It may be mentioned here that ammeters of range lower than 25 μA are not likely to be robust on account of extremely delicate construction required for proper sensitivity. Thus instruments of range lower than 25 μA are normally not manufactured. Voltmeters of all ranges use a moving coil together with sufficient series resistance (known as multiplier) to limit the instrument current to the desired value.

D.C. ammeters are normally designed to have a voltage drop of nearly 50 mV to 100 mV for full scale deflection.

Most d.c. voltmeters are designed to produce full scale deflection with a current of 20, 10, 5 or 1 mA. Normally a value of 1 mA is used.

Thus, excluding low range current measuring instruments, most d.c. ammeters are actually 50 mV (or 100 mV) millivoltmeters operated with a suitable shunt, while voltmeters are low range milli-ammeters operated with a suitable series resistance.

Example 8.1. A permanent magnet moving coil instrument has a coil of dimensions 15 mm \times 12 mm. The flux density in the air gap is 1.8×10^{-3} Wb/m² and the spring constant is 0.14×10^{-6} Nm/rad. Determine the number of turns required to produce an angular deflection of 90 degrees when a current of 5 mA is flowing through the coil.

Solution: Deflection $\theta = 90^\circ = \pi/2$ rad.

At equilibrium $T_s = T_c$, $NBI dl = K\theta$

$$\therefore \text{Number of turns } N = \frac{K\theta}{BI dl} = \frac{0.14 \times 10^{-6} \times \pi/2}{1.8 \times 10^{-3} \times 15 \times 10^{-3} \times 12 \times 10^{-3} \times 5 \times 10^{-3}} = 136.$$

Example 8.2. A moving coil voltmeter with a resistance of 20Ω gives a full scale deflection of 120° when a potential difference of 100 mV is applied across it. The moving coil has dimensions of $30 \text{ mm} \times 25 \text{ mm}$ and is wound with 100 turns. The control spring constant is $0.375 \times 10^{-6} \text{ Nm/deg}$. Find the flux density in the air gap. Find also the diameter of copper wire of coil winding if 30 percent of instrument resistance is due to coil winding.

Specific resistance for copper = $1.7 \times 10^{-8} \Omega \text{m}$.

Solution. Voltage across instrument for full scale deflection = 100 mV .

Current in instrument for full scale deflection $I = \frac{V}{R} = \frac{100 \times 10^{-3}}{20} = 5 \times 10^{-3} \text{ A}$.

Deflection torque $T_d = NBl dI = 100 \times B \times 30 \times 10^{-3} \times 25 \times 10^{-3} \times 5 \times 10^{-3} = 375 \times 10^{-6} B \text{ N-m}$.

\therefore Controlling torque for a deflection $\theta = 120^\circ$,

$$T_c = K\theta = 0.375 \times 10^{-6} \times 120 = 44 \times 10^{-6} \text{ N-m}$$

At final steady position, $T_d = T_c$ or $375 \times 10^{-6} B = 44 \times 10^{-6}$

\therefore Flux density in the air gap $B = \frac{44 \times 10^{-6}}{375 \times 10^{-6}} = 0.12 \text{ Wb/m}^2$.

Resistance of winding $R_c = 0.3 \times 20 = 6 \Omega$.

Length of mean turn $L_{mt} = 2(l+d) = 2(30+25) = 110 \text{ mm}$.

Let a be the area of cross-section of wire and ρ be the resistivity.

Resistance of coil $R_c = \frac{N\rho L_{mt}}{a}$

\therefore Area of cross-section of wire $a = \frac{100 \times 1.7 \times 10^{-8} \times 110 \times 10^{-3}}{6} = 31.17 \times 10^{-9} \text{ m}^2$
 $= 31.17 \times 10^{-3} \text{ mm}^2$.

Diameter of wire $d = \left(\frac{4}{\pi} \times 31.17 \times 10^{-3} \right)^{1/2} = 0.2 \text{ mm}$.

Example 8.3. The coil of a moving coil voltmeter is 40 mm long and 30 mm wide and has 100 turns on it. The control spring exerts a torque of $240 \times 10^{-6} \text{ N-m}$ when the deflection is 100 divisions on full scale. If the flux density of the magnetic field in the air gap is 1.0 Wb/m^2 , estimate the resistance that must be put in series with the coil to give one volt per division. The resistance of the voltmeter coil may be neglected.

Solution : Controlling torque at full scale deflection $T_c = 240 \times 10^{-6} \text{ N-m}$.

Deflecting torque at full scale deflection

$$T_d = NBl dI = 100 \times 1 \times 40 \times 10^{-3} \times 30 \times 10^{-3} I = 120 \times 10^{-3} I \text{ N-m}$$

At final steady position, $T_d = T_c$ or $120 \times 10^{-3} I = 240 \times 10^{-6}$.

\therefore Current at full scale deflection $I = 2 \times 10^{-3} \text{ A} = 2 \text{ mA}$

Let the resistance of the voltmeter circuit be R . \therefore Voltage across the instrument = $2 \times 10^{-3} R$.

This produces a deflection of 100 divisions. \therefore Volts per division = $\frac{2 \times 10^{-3} R}{100}$

This value should be equal to 1 in order to get 1 volt per division.

$\therefore \frac{2 \times 10^{-3}}{100} R = 1$ or $R = 50,000 \Omega = 50 \text{ k}\Omega$.

8.9. Ammeter Shunts. The basic movement of a d.c. ammeter is a PMMC d'Arsonval galvanometer. The coil winding of a basic movement is small and light and can carry very small

currents since the construction of an accurate instrument with a moving coil to carry currents greater than 100 mA is impracticable owing to the bulk and weight of the coil that would be required.

When heavy currents are to be measured, the major part of the current is bypassed through a low resistance called a "shunt". Fig. 8.6 shows the basic movement (meter) and its shunt to produce an ammeter.

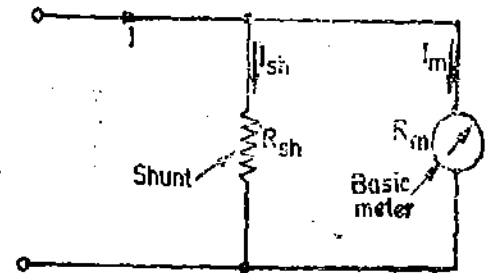

Fig. 8.6. Basic ammeter circuit.

The resistance of the shunt can be calculated using conventional circuit analysis. See Fig. 8.6,

where R_m = internal resistance of movement (i.e. the coil),
 $I_m = I_{fs}$ = full scale deflection current of movement,
 I = current to be measured.

R_{sh} = resistance of the shunt,
 I_{sh} = shunt current,

Since the shunt resistance is in parallel with the meter movement, the voltage drops across shunt and movement must be the same.

$$\text{or} \quad I_{sh} R_{sh} = I_m R_m \quad \therefore R_{sh} = \frac{I_m R_m}{I_{sh}} \quad \dots(8.9)$$

$$\text{But } I_{sh} = I - I_m, \text{ therefore we can write } R_{sh} = \frac{I_m R_m}{I - I_m} \quad \dots(8.10)$$

$$\therefore \frac{I}{I_m} - 1 = \frac{R_m}{R_{sh}} \quad \text{or} \quad \frac{I}{I_m} = 1 + \frac{R_m}{R_{sh}} \quad \dots(8.11)$$

This ratio of total current to the current in the movement is called **Multiplying Power of shunt.**

$$\therefore \text{ Multiplying power } m = \frac{I}{I_m} \quad \dots(8.12)$$

$$= 1 + \frac{R_m}{R_{sh}} \quad \dots(8.13)$$

$$\therefore \text{ Resistance of shunt } R_{sh} = \frac{R_m}{m - 1} \quad \dots(8.14)$$

The shunt resistance used with a d'Arsonval movement may consist of a coil of resistance wire within the case of the instrument, or it may be external shunt having a very low resistance.

Construction of Shunts. The general requirements for shunts are :

- (i) the temperature co-efficient of shunt and instrument should be low and should be as nearly as possible the same ;
- (ii) the resistance of shunts should not vary with time ;
- (iii) they should carry the current without excessive temperature rise ;
- (iv) they should have a low thermal electromotive force.

'Manganin' is usually used for shunts of d.c. instruments as it gives low value of thermal emf with copper although it is liable to corrosion and is difficult to solder. 'Constantan' is a useful material for a.c. circuits since its comparatively high thermal emf, being unidirectional, is ineffective on these circuits.

The construction of shunts is the same as that of low resistance standards explained in Art. 5.9. Shunts for low currents are enclosed in the meter casing but for currents above 200 A they are mounted separately.

Shunts for heavy currents are mounted externally. Fig. 8.7 shows an external shunt. It consists of evenly spaced sheets of resistive material welded into large blocks of heavy copper on each end of sheets. The resistance material has a very low temperature co-efficient and a low thermal electric effect between the resistance material and the copper. The heavy lugs (current terminals) on each end of the shunt carry the load current while the binding posts (potential terminals) on each end of the shunt are used to connect the ammeter to the shunt and carry only the current which passes through the meter (movement).

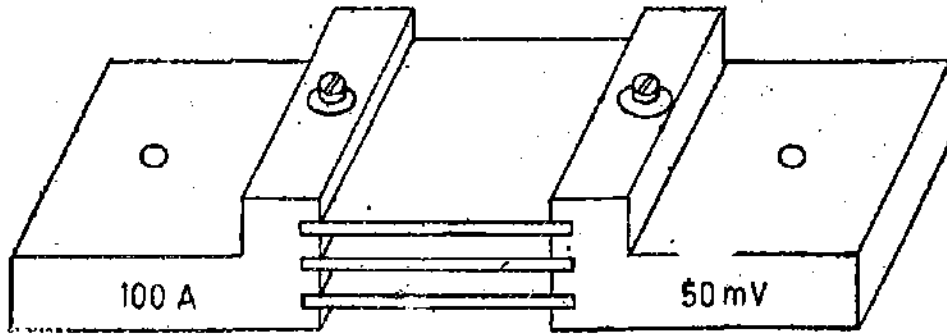

Fig. 8.7. Shunt for heavy currents.

Meters using external shunts are usually designed to operate at a full scale voltage rating. These ratings are usually 50, 75 or 100 mV. This is the voltage across the potential terminals of the shunt when full scale current flows through the load. Inasmuch as the current producing the meter deflection is a function of the voltage drop across the potential terminals of the shunt and the resistance of the instrument including the leads, the meter used with external shunts must have leads with a specified resistance to accompany the meter. Leads supplied with the instrument should never be changed and also no portion of the leads should be cut off otherwise it will lead to serious calibration errors.

Example 8.4. A 1-mA meter movement with an internal resistance of 100Ω is to be converted into a 0–100 mA ammeter, calculate the shunt resistance required. What particulars should be specified on the shunt?

Solution. Shunt resistance $R_{sh} = \frac{I_m R_m}{I - I_m} = \frac{1 \times 100}{100 - 1} = 1.01 \Omega$.

Voltage drop across the shunt $= (1.0)(100) = 100 \text{ mV}$.

Equivalent resistance of shunt in parallel with meter $= \frac{100 \times 10^{-3}}{100 \times 10^{-3} + 1.0} = 1.0 \Omega$

Therefore the indications on the shunt should be 100 mA, 100 mV

or 1.0Ω , 100 mA or 1.0Ω , 100 mV.

Example 8.5. Find the multiplying power of a shunt of 200Ω resistance used with a galvanometer of 1000Ω resistance. Determine the value of shunt resistance to give a multiplying power of 50.

Solution. Multiplying power $m = 1 + \frac{R_m}{R_{sh}} = 1 + \frac{1000}{200} = 6$.

We have $m = 1 + \frac{R_m}{R_{sh}}$

\therefore Shunt resistance $R_{sh} = \frac{R_m}{m - 1} = \frac{1000}{50 - 1} = 20.4 \Omega$.

Example 8.6. A moving coil ammeter has a fixed shunt of 0.02Ω . With a coil resistance

of $R=1000 \Omega$ and a potential difference of 500 mV across it, full scale deflection is obtained : (a) To what shunted current does this correspond ? (b) Calculate the value of R to give full scale deflection when shunted current I is (i) 10 A, (ii) 75 A and (c) With what value of R is 40% deflection obtained with $I=100$ A ?

Solution. (a) Current through shunt $I_{sh} = \frac{500 \times 10^{-3}}{0.02} = 25$ A.

Current through the meter to give full scale deflection = $\frac{500 \times 10^{-3}}{1000} = 0.5 \times 10^{-3}$ A.

(b) (i) Voltage across shunt for a current of 10 A = $0.02 \times 10 = 0.2$ V.

\therefore Resistance of meter for a current of 10 A to give full scale deflection = $\frac{0.2}{0.5 \times 10^{-3}} = 400 \Omega$.

(ii) Voltage across shunt for a current of 75 A = $0.02 \times 75 = 1.5$ V.

Resistance of meter for a current of 75 A to give full scale deflection = $\frac{1.5}{0.5 \times 10^{-3}} = 3000 \Omega$.

(c) Now 40 percent deflection is obtained with 100 A

\therefore Current to give full scale deflection = $\frac{100}{0.4} = 250$ A.

Voltage across shunt for a current of 250 A = $0.02 \times 250 = 5.0$ V

Resistance of meter for a current of 100 A to give 40 percent of full scale deflection

$$= \frac{5.0}{0.5 \times 10^{-3}} = 10,000 \Omega.$$

Example 8.7. A simple shunted ammeter using a basic meter movement with an internal resistance of 1800Ω and a full scale deflection current of $100 \mu\text{A}$ is connected in a circuit and gives a reading of 3.5 mA on its 5 mA scale. This reading is checked with a recently calibrated d.c. ammeter which gives a reading of 4.1 mA. The implication is that the first ammeter has a faulty shunt on its 5 mA range. Calculate (a) the actual value of faulty shunt ; (b) the correct shunt for the 5 mA range.

Solution : Correct multiplying power of shunt $m = \frac{I}{I_m} = \frac{5 \times 10^{-3}}{100 \times 10^{-6}} = 50$.

Multiplying power of faulty shunt = $50 \times \frac{4.1}{3.5} = 58.6$.

Resistance value of faulty shunt = $\frac{1800}{58.6 - 1} = 31.3 \Omega$.

Correct value of shunt resistance = $\frac{1800}{50 - 1} = 36.8 \Omega$.

8.10. Arrangement for Temperature Effect Correction. The temperature error can be eliminated when the shunt and the moving-coil are made of the same material and kept at the same temperature. This method, however, is not satisfactory in practice as the temperature of the two parts are not likely to change at the same rate. An additional disadvantage of using copper shunts is that they are likely to be bulky as the resistivity of copper is small. Copper shunts are only occasionally used in instruments with built-in shunts.

The arrangement normally used is shown in Fig. 8.8. In this case 'swamping' resistance of manganin (which has a negligible temperature co-efficient) having a resistance 20 to 30 times the coil resistance is connected in series with the coil and a shunt of manganin is connected

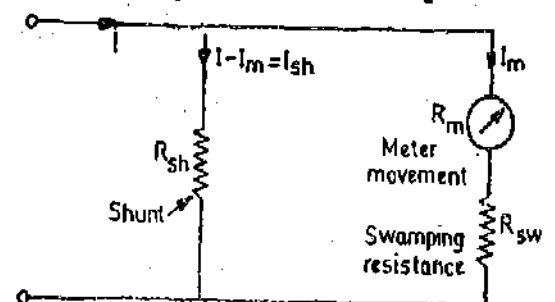

Fig. 8.8. Meter shunt and swamping resistance.

across this combination. Since copper forms a small fraction of the series combination, the proportion in which the currents would divide between the meter and the shunt would not change appreciably with the change in temperature. This fact is illustrated with the following example.

Example 8.8. A moving coil instrument whose resistance is 25 ohm gives a full-scale deflection with a current of 1 mA. This instrument is to be used with a manganin shunt to extend its range to 100 mA. Calculate the error caused by a 10°C rise in temperature when :

- (a) copper-moving coil is connected directly across the manganin shunt,
 (b) a 75-ohm manganin resistance is used in series with the instrument moving-coil.

The temperature co-efficient of copper is 0.004 °C and that of manganin 0.00015 °C.

Solution :

Case (a). Refer to Fig. 8.6.

$$\text{Shunt multiplying-factor } m = \frac{I}{I_m} = \frac{100}{1} = 100$$

$$\therefore \text{Resistance of shunt } R_{sh} = \frac{R_m}{m-1} = \frac{25}{99} = 0.2525 \Omega.$$

Instrument resistance for 10°C rise in temperature, $R_{mt} = 25(1 + 10 \times 0.004) = 26 \Omega.$

Shunt resistance for 10°C rise in temperature, $R_{sh1} = 0.2525(1 + 10 \times 0.00015) = 0.2529 \Omega.$

Current I_{mt} through the meter for 100 mA in the main circuit for 10°C rise in temperature

$$I_{mt} = 100 \times \frac{0.2529}{26 + 0.2529} = 0.963 \text{ mA.}$$

Normal meter current = 1 mA.

$$\therefore \text{Error due to rise in temperature} = (0.963 - 1) \times 100 = -3.7\%.$$

Case (b) Refer to Fig. 8.8. Total resistance in the meter circuit $R_m + R = 25 + 75 = 100 \Omega.$

$$\text{Shunt resistance } R_{sh} = \frac{R_m}{m-1} = \frac{100}{99} = 1.01 \Omega$$

Resistance of the instrument circuit for 10°C rise in temperature

$$R_{mt} = 25(1 + 10 \times 0.004) + 75(1 + 10 \times 0.00015) = 101.11 \Omega.$$

Shunt resistance for 10°C rise in temperature, $R_{sh1} = 1.01(1 + 10 \times 0.00015) = 1.0115 \Omega.$

Instrument current for 100 mA in the main circuit for 10°C rise in temperature

$$= 100 \times \frac{1.0115}{101.11 + 1.0115} = 0.9903 \text{ mA.}$$

$$\therefore \text{Error} = (0.9903 - 1) \times 100 = -0.97\%.$$

The improvement in the error from 3.7% to about 1% has been obtained by the use of the additional series swamping resistance of 3 times as compared to the meter resistance. We could obtain better correction by increasing the ratio of the swamping resistance as compared to the meter resistance. But by increasing this ratio, the p.d. across the meter circuit would also be increased. Thus the disadvantage of using swamping resistors is a reduction in the full scale sensitivity as a higher voltage across the instrument is necessary to sustain the full scale current.

8.11. Multi-range Ammeters. The current range of a d.c. ammeter may be further extended a by a number of shunts, selected by a range switch. Such meter is called a multirange ammeter. Fig. 8.9. shows a schematic diagram of multirange ammeter. The circuit has four shunts R_{sh1} , R_{sh2} , R_{sh3} and R_{sh4} , which can be put in parallel with the meter movement to give four different current ranges I_1 , I_2 , I_3 , and I_4 .

Low range ammeters use a multiposition make before break switch (See in Fig. 8.8) provided on the case of the instrument. This type of switch is essential in order that the meter movement is not damaged when changing from the

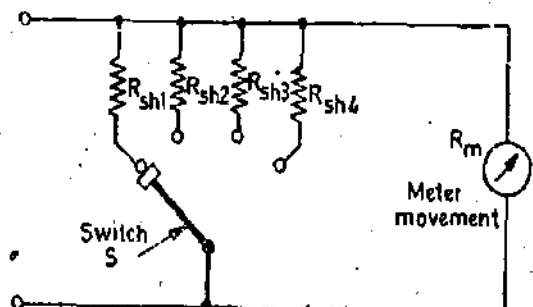

Fig. 8.9. Multi-range ammeter.

current range to another. If we provide an ordinary switch, the meter remains without a shunt and as such is unprotected when the range is changed.

When larger currents are used the connections are brought out to binding posts and the loads are connected directly to the binding post which is identified with the described current range.

Multi-range ammeters are used for ranges from 1 to 50 A. When using a multi-range ammeter, first use the highest current range, then decrease the current range until good upscale reading is obtained.

The universal shunt or Ayrton shunt shown in Fig. 8'10 is also used for multi-range ammeters. The advantage of an Ayrton shunt is that it eliminates the possibility of the meter being in the circuit without a shunt. But this advantage is gained at the cost of a higher meter resistance.

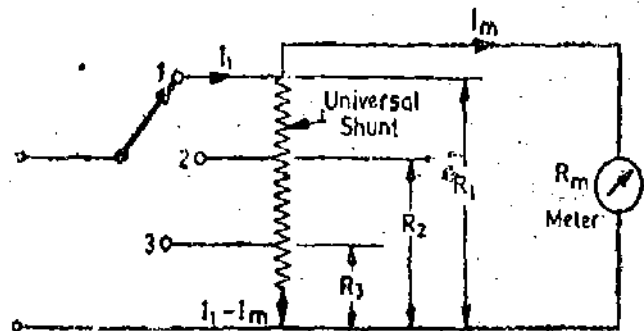

Fig. 8'10. Multi-range ammeter using universal shunt.

Universal Shunt. The universal shunt is presented here in a different form.

Consider that the meter ranges have to be extended to $I_1, I_2,$ and I_3 . For the arrangement shown in Fig. 8'10, we have, for switch at position 1,

$$I_m R_m = (I_1 - I_m) R_1$$

$$\therefore m_1 = \frac{I_1}{I_m} = 1 + \frac{R_m}{R_1} \quad \text{or } R_1 = \frac{R_m}{m_1 - 1}$$

$$\text{For switch at position 2, } I_m(R_1 - R_2 + R_m) = (I_2 - I_m)R_2 \quad \text{or } R_2 = \frac{R_1 + R_m}{m_2}$$

$$\text{For switch at position 3, } I_m(R_1 - R_3 + R_m) = (I_3 - I_m)R_3 \quad \text{or } R_3 = \frac{R_1 + R_m}{m_3}$$

Thus the values of different selections of resistances *i.e.* $(R_1 - R_2), (R_1 - R_3),$ and R_3 may be found.

Example 8'9. Design a multi-range d.c. milli-ammeter using a basic movement with an internal resistance $R_m = 50 \Omega$ and a full scale deflection current $I_m = 1 \text{ mA}$. The ranges required are 0–10 mA ; 0–50 mA ; 0–100 mA, and 0–500 mA.

Solution. 0–10 mA range :

$$\text{Multiplying power } m = \frac{I}{I_m} = \frac{10}{1} = 10$$

$$\text{From Eqn. 8'14, resistance of shunt } R_{sh1} = \frac{R_m}{m-1} = \frac{50}{9} = 5.55 \Omega.$$

$$\text{(ii) 0–50 mA range } m = \frac{50}{1} = 50 \quad \therefore R_{sh2} = \frac{R_m}{m-1} = \frac{50}{49} = 1.03 \Omega$$

$$\text{(iii) 0–100 mA range } m = \frac{100}{1} = 100 \quad \therefore R_{sh3} = \frac{50}{99} = 0.506 \Omega.$$

$$\text{(iv) 0–500 mA range } m = \frac{500}{1} = 500 \quad \therefore R_{sh4} = \frac{50}{499} = 0.1 \Omega.$$

Thus the shunt resistance required are 5.55 Ω , 1.03 Ω , 0.506 Ω and 0.1 Ω .

Example 8'10. Design an Ayrton shunt to provide an ammeter with current ranges of 1 A, 5 A and 10 A. A basic meter with an internal resistance of 50 Ω and a full scale deflection current of 1 mA is to be used.

Solution. Referring to Fig. 8'10, we have, $I_m = 1 \text{ mA}$, $R_m = 50 \Omega$
and $I_1 = 1 \text{ A}$, $I_2 = 5 \text{ A}$, $I_3 = 10 \text{ A}$.

$$\text{Thus } m_1 = \frac{1}{1 \times 10^{-3}} = 1000, m_2 = \frac{5}{1 \times 10^{-3}} = 5000, m_3 = \frac{10}{1 \times 10^{-3}} = 10,000$$

$$\text{Thus } R_1 = \frac{R_m}{m_1 - 1} = \frac{50}{1000 - 1} \approx 0.05 \Omega, R_2 = \frac{R_1 + R_m}{m_2} = \frac{0.05 + 50}{5000 - 1} \approx 0.01 \Omega$$

$$R_3 = \frac{R_1 + R_m}{m_3} = \frac{0.05 + 50}{10,000 - 1} = 0.005 \Omega.$$

Therefore the resistances of the various sections of the universal shunt are :

$$R_1 - R_2 = 0.05 - 0.01 = 0.040 \Omega, R_2 - R_3 = 0.01 - 0.005 = 0.005 \Omega, \text{ and } R_3 = 0.005 \Omega.$$

8'12. **Voltmeter Multipliers.** A d'Arsonval basic meter movement is converted into a voltmeter by connecting a series resistance with it. This series resistance is known as a multiplier. The combination of the meter movement and the multiplier is put across the circuit whose voltage is to be measured. (See Fig. 8'11).

The multiplier limits the current through the meter so that it does not exceed the value for full scale deflection and thus prevents the movement from being damaged.

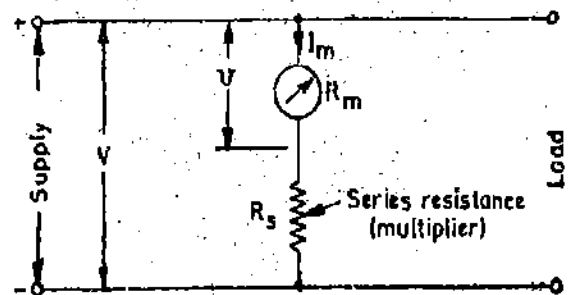

Fig. 8'11. Meter with a multiplier.

The value of a multiplier, required to extend the voltage range, is calculated as under :

- Let $I_m = I_{fs}$ = full scale deflection current of meter,
 R_m = internal resistance of meter movement,
 R_s = multiplier resistance,
 v = voltage across the meter movement for current I_m ,
 V = full range voltage of instrument.

$$\text{For the circuit of Fig. 8'10, } v = I_m R_m \quad \dots(8'15)$$

$$V = I_m (R_m + R_s) \quad \dots(8'16)$$

$$\therefore R_s = \frac{V - I_m R_m}{I_m} = \frac{V}{I_m} - R_m \quad \dots(8'17)$$

We can also express the result in terms of multiplying factor of multiplier.

$$\text{Multiplying factor for multiplier } m = \frac{V}{v} = \frac{I_m (R_m + R_s)}{I_m R_m} = 1 + \frac{R_s}{R_m} \quad \dots(8'18)$$

$$\therefore \text{ Resistance of multiplier } R_s = (m - 1) R_m \quad \dots(8'19)$$

Hence for the measurement of voltage m times the voltage range of the instrument, the series multiplying resistance should be $(m - 1)$ times the meter resistance. Thus to extend the voltage range to 10 times the instrument range, $R_s = 9 R_m$.

Construction of Multipliers. The essential requirements of multipliers are :

- (i) their resistance should not change with time ;
- (ii) the change in their resistance with temperature should be small ;
- (iii) they should be non-inductively wound for a.c. meters.

The resistance materials used for multipliers are manganin and constantan.

The general constructional details of multipliers are the same as that for medium and high resistances as explained in chapter 4.

Multipliers are mounted inside the instrument case for voltages up to 500 V. For higher voltages, the multipliers may be mounted separately outside the case on a pair of binding posts to avoid excessive heating inside the case.

Example 8'11. A moving coil instrument gives a full scale deflection of 10 mA when the potential difference across its terminals is 100 mV. Calculate (a) the shunt resistance for a full scale deflection corresponding to 100 A, (b) the series resistance for full scale reading with 1000 V. Calculate the power dissipation in each case.

Solution. Meter current $I_m = 10 \text{ mA}$.

Meter resistance $R_m = \frac{100 \text{ mV}}{10 \text{ mA}} = 10 \Omega$.

(a) Shunt multiplying factor $m = \frac{I}{I_m} = \frac{10}{10 \times 10^{-3}} = 10,000$.

\therefore Shunt resistance $R_{sh} = \frac{R_m}{m-1} = \frac{10}{10,000-1} \approx 0.001 \Omega$.

Power dissipation $= (100 \times 10^{-3}) \times 100 = 10 \text{ W}$.

(b) Voltage multiplying factor $m = \frac{V}{v} = \frac{1000}{100 \times 10^{-3}} = 10,000$.

\therefore Multiplier resistance $R_s = (m-1) R_m = (10,000-1) \times 10 \approx 100,000 \Omega$.

Power dissipation $= V I_m = (1000) (10 \times 10^{-3}) = 10 \text{ W}$.

8'13. Effect of Temperature Changes. The multiplier resistance used in series with the moving-coil is usually made of manganin having a negligible resistance temperature coefficient. Since the series resistance of the multiplier is very much greater than the coil resistance (which is of copper), the variations of resistance of R_m due to temperature changes are 'swamped' by the resistance R_s of multiplier.

This is illustrated by the following example.

Example 8'12. A moving-coil instrument whose resistance is 25Ω gives a full-scale deflection with a voltage of 25 mV. This instrument is to be used with a series multiplier to extend its range to 10 V. Calculate the error caused by 10°C rise in temperature.

The temperature coefficient of copper is $0.004 \Omega/\Omega^\circ\text{C}$ and that of manganin $0.00015 \Omega/\Omega^\circ\text{C}$.

Solution. Meter current for full scale deflection

$$I_m = \frac{V}{R_m} = \frac{25 \times 10^{-3}}{25} = 10^{-3} \text{ A} = 1 \text{ mA}$$

Voltage multiplying factor $m = \frac{V}{v} = \frac{10}{25 \times 10^{-3}} = 400$.

Multiplier resistance $R_s = (m-1) R_m = (400-1) 25 = 9975 \Omega$.

Total resistance of voltmeter circuit $R_v = 25 + 9975 = 10,000 \Omega$.

Resistance of meter with 10°C rise in temperature

$$R_{mt} = R_m(1 + \alpha t) = 25(1 + 0.004 \times 10) = 26 \Omega$$

Resistance of multiplier with 10°C rise in temperature

$$R_{st} = R_s(1 + \alpha t) = 9975(1 + 0.00015 \times 10) = 9976.5 \Omega$$

Total resistance of voltmeter circuit with 10°C rise in temperature

$$R_{vt} = 26 + 9976.5 = 10,002.5 \Omega$$

Reading of voltmeter at 10°C rise in temperature = $\frac{10,000}{10,002.5} \times 10 = 9.9975 \text{ V}$

Percentage error = $\frac{9.9975 - 10}{10} \times 100 = 0.025\% \text{ low.}$

Thus it is clear from above that the temperature changes have no appreciable effect on the readings of voltmeters if the multipliers are made of low temperature coefficient materials, i.e., the temperature changes are swamped out by the multipliers.

8.14. Multirange d.c. Voltmeters. In a multirange voltmeter, different full scale voltage ranges may be obtained by the use of individual multiplier resistors or by a potential divider arrangement.

1. Individual Multipliers. We can obtain different voltage ranges by connecting different values of multiplier resistors in series with the meter. The number of these resistors is equal to the number of ranges required. Fig. 8.12 shows multiplier resistors R_{s1}, R_{s2}, R_{s3} and R_{s4} which can be connected in series with the meter by a range selector switch. Consider that the ranges desired are V_1, V_2, V_3 and V_4 , then the corresponding multiplier resistances can be obtained by Eqn. 8.19. We have

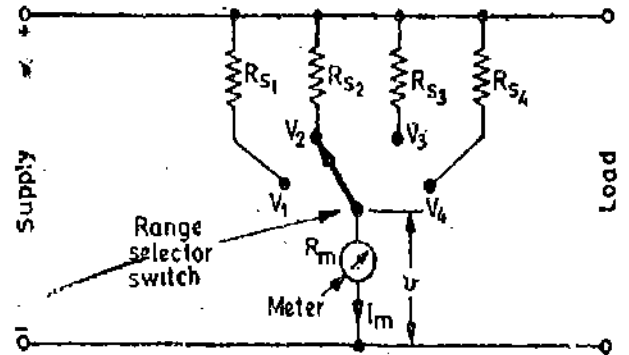

Fig. 8.12. Multirange voltmeter.

$$R_{s1} = (m_1 - 1) R_m, R_{s2} = (m_2 - 1) R_m \dots (8.20)$$

$$R_{s3} = (m_3 - 1) R_m, R_{s4} = (m_4 - 1) R_m$$

where $m_1 = \frac{V_1}{v}, m_2 = \frac{V_2}{v}, m_3 = \frac{V_3}{v}$ and $m_4 = \frac{V_4}{v}$.

2. Potential Divider Arrangement. Another multi-range voltmeter is shown in Fig. 8.13 in which the connections are made at the junctions of resistances R_1, R_2, R_3 and R_4 in series to obtain the voltage ranges V_1, V_2, V_3 and V_4 . These connections are brought out to binding posts on the instrument, and the instrument is connected to the proper binding post for the desired voltage range. The series resistances for the voltage ranges V_1, V_2, V_3 and V_4 can be computed as follows :

$$R_1 = \frac{V_1}{I_m} - R_m = \frac{V_1}{v/R_m} - R_m = m_1 R_m - R_m = (m_1 - 1) R_m \dots (8.21)$$

$$R_2 = \frac{V_2}{I_m} - R_m - R_1 = \frac{V_2}{v/R_m} - R_m - (m_1 - 1) R_m$$

$$= m_2 R_m - R_m - (m_1 - 1) R_m = (m_2 - m_1) R_m \dots (8.22)$$

Similarly $R_3 = \frac{V_3}{I_m} - R_m - R_1 - R_2 = (m_3 - m_2) R_m \dots (8.23)$

and $R_4 = \frac{V_4}{I_m} - R_m - R_1 - R_2 - R_3 = (m_4 - m_3) R_m \dots (8.24)$

This system has the advantage that all multipliers except the first have standard resistance values and can be obtained commercially in precision tolerances. The range multiplier, R_1 , is the only special resistor which must be manufactured to meet specific circuit requirements.

Multi-range voltmeters are very effective for moderate range voltages. For higher-range voltages it is often desirable to use external resistors in connection with a given voltmeter.

In using a multi-range voltmeter it is usual procedure first to connect the voltmeter to the highest voltage range terminal or set the switch to the highest voltage which the instru-

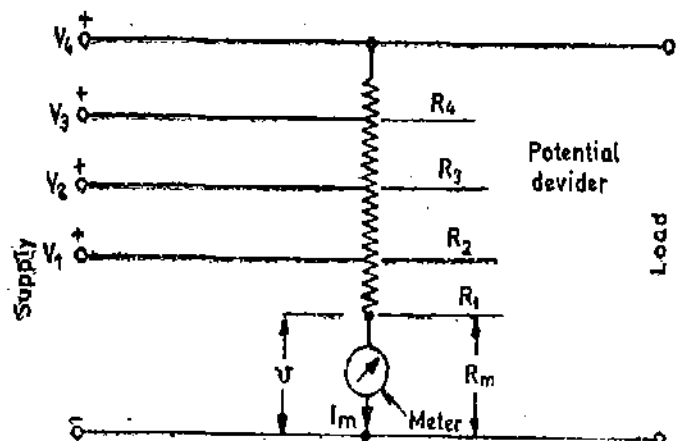

Fig. 8.13. Multi-range voltmeter using potential divider.

ment will read. Then connect the instrument to the circuit and measure the voltage. Then decrease the ranges of the instrument until a good upscale reading is obtained on the voltmeter.

Example 8'13. A basic d'Arsonval meter movement with an internal resistance $R_m = 100 \Omega$, and a full scale current of $I_m = 1 \text{ mA}$, is to be converted into a multi-range d.c. voltmeter with ranges of 0–10 V, 0–50 V, 0–250 V and 0–500 V. Find the values of various resistances using the potential divider arrangement.

Solution. Voltage across the meter movement $v = I_m R_m = 1 \times 100 = 100 \text{ mV}$.

The voltage multiplying factors are :

$$m_1 = \frac{10}{100 \times 10^{-3}} = 100; \quad m_2 = \frac{50}{100 \times 10^{-3}} = 500;$$

$$m_3 = \frac{250}{100 \times 10^{-3}} = 2500; \quad m_4 = \frac{500}{100 \times 10^{-3}} = 5000.$$

Referring to Fig. 8'13, and using Eqns. 8'21–8'24 the values of various resistances are :

$$R_1 = (m_1 - 1)R_m = (100 - 1) \times 100 = 9900 \Omega,$$

$$R_2 = (m_2 - m_1)R_m = (500 - 100) \times 100 = 40 \times 10^3 \Omega = 40 \text{ k}\Omega,$$

$$R_3 = (m_3 - m_2)R_m = (2500 - 500) \times 100 \Omega = 200 \text{ k}\Omega,$$

and

$$R_4 = (m_4 - m_3)R_m = (5000 - 2500) \times 100 \Omega = 250 \text{ k}\Omega.$$

8'15. Sensitivity. The current sensitivity is defined as the deflection per unit current and this is equal to the ratio of constant G of the electrical system divided by the control-spring constant K . Hence for sensitivity to be large G should be large and K should be small. For a given coil area $A (=ld)$ and a constant flux density, G can be increased when the coil is wound with many turns of thin wire while K can be made small by using a light flat spring and the coil assembly lightly pivoted. On the contrary a less sensitive instrument is wound with few turns of thick wire and has a stiffer spring. Thus as a general rule it may be stated that a sensitive instrument will have a large resistance because it is wound with many turns of fine wire. As a basis of comparison between instruments of different sensitivities, the sensitivity [of the instrument may be defined as the current necessary to give full scale deflection. Modern moving coil instruments has sensitivity in the range from 25 μA to 10 mA.

8'16. Voltmeter Sensitivity and Loading Effects. As stated above, the resistance of a meter is an indication of its sensitivity, it is usual practice to specify the sensitivity of a voltmeter in terms of Ω/V . The sensitivity of a voltmeter is defined as

$$S_v = \frac{1}{I_{fs}} = \frac{1}{I_m} \Omega/\text{V}$$

where

I_{fs} = current required for full scale deflection.

The sensitivity S_v of the voltmeter may be used to advantage in the sensitivity method of calculating the multiplier in a d.c. voltmeter. Consider the circuit of Fig. 8'12.

$$\therefore R_1 = S_v V_1 - R_m \quad \dots(8'25)$$

$$R_2 = S_v V_2 - (R_m + R_1) \quad \dots(8'26)$$

$$R_3 = S_v V_3 - (R_m + R_1 + R_2) \quad \dots(8'27)$$

$$R_4 = S_v V_4 - (R_m + R_1 + R_2 + R_3) \quad \dots(8'28)$$

Example 8'14. Solve example 8'13 by voltage sensitivity method.

Solution. Sensitivity $S_v = \frac{1}{I_m} = \frac{1}{1 \times 10^{-3}} = 1000 \Omega/\text{V}$.

$$\therefore R_1 = S_v V_1 - R_m = 1000 \times 10 - 100 = 9900 \Omega,$$

$$R_2 = S_v V_2 - (R_m + R_1) = 1000 \times 50 - (100 + 9900) \Omega = 40 \text{ k}\Omega,$$

$$R_3 = S_v V_3 - (R_m + R_1 + R_2) = 1000 \times 250 - (100 + 9900 + 40,000) \Omega = 200 \text{ k}\Omega,$$

and

$$R_4 = S_v V_4 - (R_m + R_1 + R_2 + R_3).$$

$$= 1000 \times 500 - (100 + 9900 + 40,000 + 200,000) \Omega = 250 \text{ k}\Omega.$$

The sensitivity of a d.c. voltmeter is an important factor when selecting a meter for a certain voltage measurement. A low resistivity voltmeter may give correct readings when measuring voltages in low resistance circuits but is certain to produce very unreliable readings in high resistance circuits. A voltmeter, when connected across two points in a highly resistive circuit, acts as a shunt for that portion of the circuit. The meter will then give a lower voltage drop than actually existed before the meter was connected. This effect is called loading effect of an instrument and is caused principally by low sensitivity instruments.

This is illustrated by the following example :

Example 8.15. It is desired to measure the voltage across a $50 \text{ k}\Omega$ resistor in the circuit shown in Fig. 8.14. Two voltmeters are available for this purpose :

Voltmeter *A* with a sensitivity of $1000 \Omega/\text{V}$ and

Voltmeter *B* with a sensitivity of $20,000 \Omega/\text{V}$.

Both meters have $0-50 \text{ V}$ range. Calculate :

(a) the reading of each voltmeter ;

(b) the error in each reading expressed as a percentage of true value.

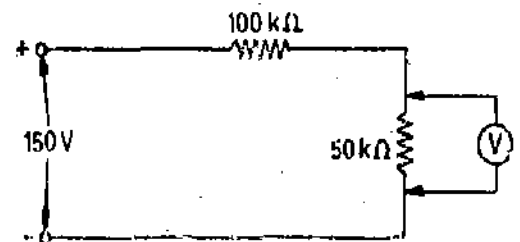

Fig. 8.14

Solution. True value of voltage across the $50 \text{ k}\Omega$ resistor $= \frac{50}{(100+50)} \times 150 = 50 \text{ V}$

(a) Voltmeter *A*. Resistance of voltmeter $R_v = S_v V = 1000 \times 50 \Omega = 50 \text{ k}\Omega$.

Now this voltmeter is connected across the $50 \text{ k}\Omega$ resistor and therefore the resistance of parallel combination of voltmeter and resistor

$$= \frac{(50) \times (50)}{(50+50)} = 50 \text{ k}\Omega.$$

Voltage across the combination of voltmeter and resistor $= \frac{25}{100+25} \times 150 = 30 \text{ V}$.

Hence voltmeter *A* indicates a voltage of 30 V .

Voltmeter *B*. Resistance of voltmeter $R_v = S_v V = 20,000 \times 50 \Omega = 100 \text{ k}\Omega$.

Resistance of combination of voltmeter in parallel with $50 \text{ k}\Omega$ resistor

$$= \frac{(1000) \times (50)}{(1000) \times (50)} = 47.6 \text{ k}\Omega.$$

\therefore Voltage across the combination of voltmeter and resistor $= \frac{47.6}{100+47.6} \times 150 = 48.36 \text{ V}$.

Hence voltmeter *B* indicates a voltage of 48.36 V .

(b) Voltmeter *A*. Percentage error $= \frac{\text{indicated voltage} - \text{true voltage}}{\text{true voltage}} \times 100$

$$= \frac{30 - 50}{50} \times 100 = -40\%$$

Voltmeter *B*. Percentage error $= \frac{48.36 - 50}{50} \times 100 = -3.28\%$

The above results indicate that the meter with higher sensitivity or ohm per volt rating gives more reliable results. This is particularly true in the cases where voltage measurements are made in high resistance circuits.

Voltage measurements in electronic circuits (where high resistances are invariably involved) are generally made with multirange voltmeters or multimeters, with sensitivities in range of 20 k Ω /V to 50 k Ω /V. In measurements of power circuits where the current is usually large voltmeters may have sensitivities as low as 100 Ω /V. The sensitivities of commercial instruments are given in Table 8'1.

TABLE 8'1
Sensitivities of Commercial Moving Coil Instruments

Current for full scale deflection	Voltage across meter	Meter resistance*	Ohm per volt
25'0 μ A	100 mV	4,000 ohm	40,000
50'0 μ A	100 mV	2,000 ohm	20,000
100'0 μ A	100 mV	1,000 ohm	10,000
200'0 μ A	100 mV	500 ohm	5,000
1'0 mA	100 mV	100 ohm	1,000
5'0 mA	50 mV	10 ohm	200
10'0 mA	50 mV	5 ohm	100
20'0 mA	50 mV	2'5 ohm	50

8'17. **Errors.** The main sources of errors in moving coil instruments are due to :

- (i) Weakening of permanent magnets due to ageing at temperature effects.
- (ii) Weakening of springs due to ageing and temperature effects.
- (iii) Change of resistance of the moving coil with temperature.

Magnets. In order to have permanence in magnetism, magnets are aged by heat and vibration treatment. This process results in the loss of initial magnetism but that remains is strongly held.

Springs. The weakening of springs with time can be reduced by careful use of material and pre-ageing during manufacture. However, the effect of weakening of springs on the performance of the instrument is opposite to that of ageing of magnets. The weakening of magnets tends to decrease the deflection for a particular value of current, while the weakening of springs tends to increase the deflection.

In permanent magnet moving coil instruments, a 1°C increase of temperature reduces the strength of springs by about 0'04 percent and reduces flux density in the air gap of the magnet by about 0'02 percent. Thus the net effect, on the average, is to increase the deflection by about 0'02 percent per °C.

Moving Coil The moving coil of a measuring instrument is usually wound with copper wire having a temperature co-efficient of 0'004 °C. When the instrument is used as a micro-ammeter or a milli-ammeter and the moving coil is directly connected to the output terminals of the instrument, the indication of the instrument for a constant current would decrease by 0'04 percent per °C rise in temperature.

In case the moving coil instrument is used as a voltmeter a large series resistance of negligible temperature co-efficient (made of material like manganin) is used. This eliminates the error due to temperature. This is because the copper coil forms a very small fraction of the total resistance of

*The resistance values given in the above table are inclusive of the swamping resistance.

the instrument circuit and thus any change in its resistance has a negligible effect on the total resistance.

The position when the instrument current range is extended by using a shunt is, however, different. The main source of error in this case is due to relatively larger change in the resistance of the copper moving coil as compared to that of the manganin shunt. This happens because copper has a much higher resistance temperature co-efficient as compared to manganin. To reduce the error in this account, it is usual to include in series with the moving-coil a 'swamping resistance' of manganin so that the copper coil forms only a small fraction of the total resistance comprising the coil and the additional swamping resistance. This swamping resistance is also used as an adjustment for the final calibration of the ammeter.

9'18. Advantages and Disadvantages. The main advantages of PMMC instruments are :

1. The scale is uniformly divided.
2. The power consumption is very low as low as $25\mu\text{W}$ to $200\mu\text{W}$.
3. The torque-weight ratio is high which gives a high accuracy. The accuracy is of the order of generally 2 percent of full scale deflection.
4. A single instrument may be used for many different current and voltage ranges by using different values for shunts and multipliers.
5. Since the operating forces are large on account of large flux densities which may be as high as 0.5 Wb/m^2 the errors due to stray magnetic fields are small.
6. Self-shielding magnets make the core magnet mechanism particularly useful in aircraft and aerospace applications, where a multiplicity of instruments must be mounted in close proximity to each other. An example of this type of mounting may be in the cross pointer indicator, where as many as five mechanisms are mounted in one case to form a unified display. This, obviously, results in elimination of iron cases and the corresponding weight reduction are of great advantage in aircraft and aerospace instruments.

The chief disadvantages are :

1. These instruments are useful only for d.c. The torque reverses if the current reverses. If the instrument is connected to a.c., the pointer cannot follow the rapid reversals and the deflection corresponds to mean torque, which is zero. Hence these instruments cannot be used for a.c.
2. The cost of these instruments is higher than that of moving iron instruments.

OHMMETERS

8'19. Introduction. The ohmmeter is a convenient direct reading device for measurement of resistance. These instruments have a low degree of accuracy. The statement regarding accuracy is not intended in an unfavourable sense there is a wide field of application for this instrument in determining the approximate value of resistance. An ohmmeter is useful for getting the approximate resistance of circuit components such as heater elements or machine field coils, measuring and sorting resistors used in electronic circuits and for checking continuity of circuits. It is also useful in laboratories as an aid to a precision bridge, for it can help to know the approximate value of resistance which can save time in balancing the bridge.

8'20. Series-type Ohmmeter. A circuit of a series-type ohmmeter is shown in Fig. 8'15. It consists of basic d'Arsonval movement connected in parallel with a shunting resistor R_2 . This parallel circuit is in series with resistance R_1 and a battery of emf E . The series circuit is connected to the terminals A and B of the unknown resistance R_x .

For Fig. 8'15 :

R_1 = current limiting resistor,

R_2 = zero adjusting resistor,

E = emf of internal battery,

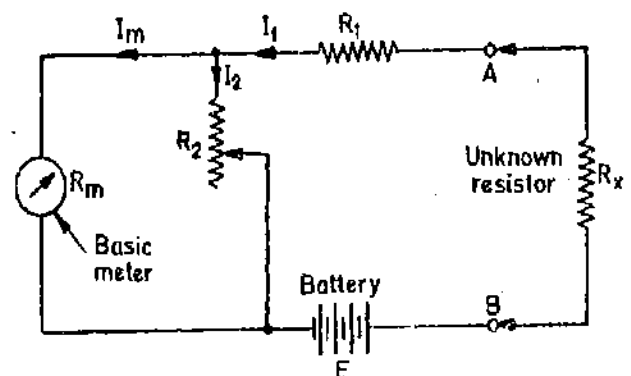

Fig. 8'15, Series-type ohmmeter,

and R_m = internal resistance of d'Arsonval movement,

It is observed that when the unknown resistance $R_x = 0$ (terminals A and B shorted) maximum current flows through the meter. Under this condition resistor R_2 is adjusted until the basic movement (meter) indicates full scale current I_{fs} . The full-scale current position of the pointer is marked "0Ω" on the scale. Similarly when R_x is removed from circuit, $R_x = \infty$ (that is when terminals A and B are open), the current in the meter drops to zero and the movement indicates zero current which is then marked " ∞ ". Thus the meter will read infinite resistance at the zero current position and zero resistance at full scale current position. Since zero resistance is indicated when the current in the meter is maximum and hence the pointer goes to the top mark. When the unknown resistance is inserted at terminals A, B the current through the meter is reduced and hence pointer drops lower on the scale. Therefore the meter has "0" at extreme right and " ∞ " at the extreme left. Intermediate scale markings may be placed on the scale by different known values of resistance R_h to the instrument. The accuracy of these scale markings depends on the repeating accuracy of the movement and the tolerances of the calibrating resistors. Fig. 8'17 (a) shows the shape of scale of series type ohmmeter.

A convenient quantity to use in the design of a series ohmmeter is the value of R_x which causes the half scale deflection of the meter. At this position, the resistance across terminals A and B is defined as the half scale position resistance R_h . The design can be approached by recognizing the fact that when R_h is connected across terminals A and B the meter current reduces to $\frac{1}{2}$ of its full scale value.

$$\text{or with } R_x = R_h, \quad I_m = \frac{1}{2} I_{fs}$$

where I_m = current through the meter, I_{fs} = current through the meter for full scale deflection. This clearly means that R_h is equal to the internal resistance of the ohmmeter looking into terminals A and B .

$$\therefore R_h = R_1 + \frac{R_2 R_m}{R_2 + R_m} \quad \dots(8'29)$$

$$\text{The battery current at half scale deflection } I_h = \frac{E}{2R_h} \quad \dots(8'30)$$

In order to produce full scale deflection the battery current must be doubled

$$\therefore I_1 = 2I_h = \frac{E}{R_h} \quad \dots(8'31)$$

$$\text{Current through the shunt } I_2 = I_1 - I_{fs} \quad \dots(8'32)$$

The voltage drop across R_2 is equal to voltage drop across meter

$$\therefore I_2 R_2 = I_{fs} R_m \text{ or } R_2 = \frac{I_{fs}}{I_2} R_m \quad \dots(8'33)$$

$$\text{Substituting Eqn. 8'32 in Eqn. 8'33 we get } R_2 = \frac{I_{fs} R_m}{I_1 - I_{fs}} = \frac{I_{fs} R_m R_h}{E - I_{fs} R_h} \quad \dots(8'34)$$

$$\text{Solving Eqn. 8'29 } R_1 = R_h - \frac{R_2 R_m}{R_2 + R_m} \quad \dots(8'35)$$

Substituting Eqn. 8'34 into Eqn. 8'35 and solving for R_1 , we get

$$R_1 = R_h - \frac{I_{fs} R_m R_h}{E} \quad \dots(8'36)$$

$$\text{From Eqn. 8'34, we have } R_h = \frac{E R_2}{I_{fs} (R_2 + R_m)} \quad \dots(8'37)$$

we observe from Eqn. 8'34, as $I_s R_h$ approaches E , the value of R_2 approaches infinity. If R_2 is to have some finite limit say $0.5 \text{ M}\Omega$, then from Eqn. 8'37,

$$R_h = \frac{500000 E}{I_s (500000 + R_m)}$$

If R_2 is to compensate for a 10% drop in battery voltage, then the maximum value of R_h is :

$$R_h = \frac{(500000)(0.9 E)}{I_s (500000 + R_m)} \approx \frac{0.9 E}{I_s} \quad \dots(8'38)$$

If the resistance R_h is to be increased beyond this value, a battery with a higher emf must be used.

Hence, in terms of full scale meter current, the resistance of meter, the battery voltage, and the measured resistance at half scale, the resistances R_1 and R_2 can be determined and the maximum value of R_h for a given battery e.m.f. can be computed.

The meter current for any resistance R_x is :

$$I_m = I_s \frac{R_2}{R_2 + R_m} \quad \text{But} \quad I_s = \frac{E}{\text{internal resistance} + R_x} = \frac{E}{R_h + R_x}$$

$$\text{or} \quad I_m = \frac{E R_2}{(R_h + R_x)(R_2 + R_m)} \quad \dots(8'39)$$

$$\text{When } R_x = 0, I_m = I_s. \quad \therefore I_s = \frac{E R_2}{R_h (R_x + R_m)} \quad \dots(8'40)$$

$$\text{Dividing Eqn. 8'39 by Eqn. 8'40 gives : } s = \frac{I_m}{I_s} = \frac{R_h}{R_x + R_h} \quad \dots(8'41)$$

where s is the fraction of full scale reading when measuring an unknown resistance R_x . Thus the scale of a given ohmmeter for a given R_h can be calibrated either by direct calibration, using known values of R_x or it can be calculated in terms of the fraction of the full scale readings, which can be computed from the resistance to be measured R_x and the half scale resistance R_h .

Although the series type ohmmeter is a popular design and is used extensively in portable instruments for general service work, its use certain difficulties. Important among these is the internal battery whose voltage decreases gradually with time and age, so that the full scale current drops down and the meter does not read '0' when terminals A and B are shorted. The variable resistor R_2 provides an adjustment to counteract the effect of battery voltage change. Without R_2 , it would be possible to bring the pointer back to full scale by adjusting resistance R_1 , but this would change the calibration all along the scale, and therefore change in resistance R_2 is a superior solution, since the parallel resistance R_2 and coil resistance R_m are always low as compared to R_1 , and thus the change in R_2 needed for adjustment does not change calibration very much. The circuit of Fig. 8'15 does not completely compensate for ageing of the battery, but it does a reasonably good job within the expected limits of accuracy of the instrument. Some ohmmeters are constructed with a soft iron shunt across the pole pieces of the meter (permanent magnet moving coil instrument). The magnetic shunt serves to modify the air gap flux density of the magnet, and hence controls the sensitivity of the meter movement. The pointer can thus be set on the full scale mark for compensation of changes in battery voltage without changing the electrical circuit. This is a great advantage as it does not alter the electrical circuit at all.

Some ohmmeters use rectified alternating current as the power source. In this case the voltage may be regulated to give a constant voltage supply.

The range of the instrument can be extended by providing proper shunts and thus the voltmeter may be designed to read resistance values over a wide range.

Example 8'16. Design a series type ohmmeter. The movement to be used requires 0.5 mA

for full scale deflection and has an internal resistance of 50Ω . The internal battery has a voltage of 3 V . The desired value of half scale resistance is 3000Ω . Calculate (a) the values of series and parallel resistances R_1 and R_2 ; (b) the range of values of R_2 , if the battery voltage may vary from 2.7 V to 3.1 V . Use the value of R_1 calculated in (a).

Solution : The value of parallel resistance

$$R_2 = \frac{I_{fs} R_m R_h}{E - I_{fs} R_h} \quad \text{(See Eqn. 8'34)}$$

$$= \frac{0.5 \times 10^{-3} \times 50 \times 3000}{3 - 0.5 \times 10^{-3} \times 3000} = 50 \Omega.$$

The internal resistance of ohmmeter is equal to the half scale resistance

or $R_1 + \frac{R_2 R_m}{R_2 + R_m} = R_h \therefore R_1 + \frac{50 \times 50}{50 + 50} = 3000$

\therefore Series resistance $R_1 = 2975 \Omega$.

The value of resistance R_2 when the battery voltage is 2.7 V :

$$R_2 = \frac{0.5 \times 10^{-3} \times 50 \times 3000}{2.7 - 0.5 \times 10^{-3} \times 3000} = 62.5 \Omega.$$

When the battery voltage is 3.1 V , $R_2 = \frac{0.5 \times 10^{-3} \times 50 \times 3000}{3.1 - 0.5 \times 10^{-3} \times 3000} = 46.88 \Omega$.

8'21. Shunt type Ohmmeters. The circuit diagram of a shunt type ohmmeter is shown in Fig. 8'16. It consists of a battery in series with an adjustable resistor R_1 and a basic d'Arsonval movement (meter). The unknown resistance is connected across terminals A and B , parallel with the meter. In this circuit it is necessary to have an "off-on" switch to disconnect the battery from the circuit when the instrument is not in use. When the unknown resistor $R_x = 0 \Omega$ (A and B are shorted), the meter current is zero. If the unknown resistance $R_x = \infty$ (A and B are open), the current finds path only through the meter and selecting a proper value for resistance R_1 , the pointer may be made to read full scale. This ohmmeter therefore has "zero" mark on the left hand side of the scale (no current) and infinite mark on the right hand side of the scale (full scale deflection current).

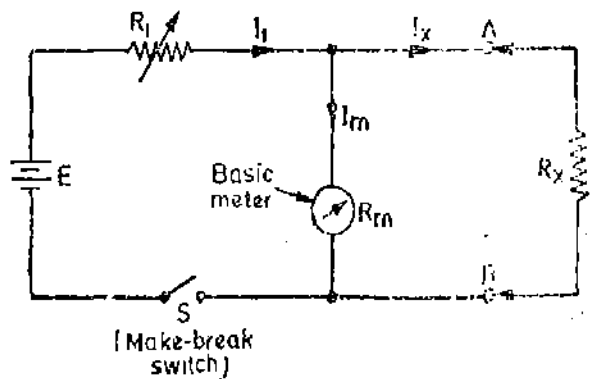

Fig. 8'16. Shunt type ohmmeter.

The analysis of the shunt type ohmmeter is similar to that of a series-type ohmmeter. In Fig. 8'16, when $R_x = \infty$, the full scale meter current is :

$$I_{fs} = \frac{E}{R_1 + R_m} \quad \dots(8'41)$$

or $R_1 = \frac{E}{I_{fs}} - R_m \quad \dots(8'42)$

With any resistance R_x to be measured, the meter current I_m is :

$$I_m = \left(\frac{E}{R_1 + \frac{R_m R_x}{R_m + R_x}} \right) \left(\frac{R_x}{R_m + R_x} \right) = \frac{E R_x}{R_1 R_m + R_x (R_1 + R_m)} \quad \dots(8'43)$$

At half scale reading of the meter, $I_m = 0.5 I_{fs}$ and $R_x = R_h$.

$$\text{Then } 0.5 I_{fs} = \frac{ER_h}{R_1 R_m + R_h(R_1 + R_m)} \quad \dots(8.44)$$

$$\text{Dividing Eqn. 8.43 by Eqn. 8.41 gives } s = \frac{I_m}{I_{fs}} = \frac{R_x(R_1 + R_m)}{R_1 R_m + R_x(R_1 + R_m)} \quad \dots(8.45)$$

$$\text{Usually } R_1 \text{ is very large as compared with } R_m \text{ and therefore } s = \frac{I_m}{I_{fs}} = \frac{R_x}{R_m + R_x} \quad \dots(8.46)$$

Thus the meter can be calibrated by computing the fraction of full scale 's' for a given resistance R_x in terms of R_x and the meter resistance R_m .

In order to determine the relative scale values for a given value of R_1 , the half scale reading may be found by dividing Eqn. 8.41 by Eqn. 8.44, and solving for R_h :

$$R_h = \frac{R_1 R_m}{R_1 + R_m} \quad \dots(8.47)$$

It is clear from the above analysis that,

(i) the battery emf E , the meter full scale current I_{fs} , and meter resistance R_m determine the resistance R_1 ,

(ii) the resistance R_1 and the meter resistance R_m determine the half scale resistance R_h .

Thus the meter-resistance scale depends only on the meter and the voltage of the battery. The battery emf is 1.5–15 V, while the full scale current of the meter may vary from 0.25 mA to 1.0 A or even more. Then R_1 will vary from 5 to 12000 Ω . Usually R_1 is considerably larger than R_m . Then

$$R_1 + R_m \approx R_1 \quad \dots(8.48)$$

Substituting this in Eqn. 8.47 gives

$$R_h \approx R_m \quad \dots(8.49)$$

The shunt-type of ohmmeter is particularly suited for the measurement of low value resistors. It is not a commonly used instrument, but it is found in laboratories or for low resistance applications.

The shape of scales of series and shunt type of ohmmeters are given in Fig. 8.17.

To illustrate that the shunt-type ohmmeter is particularly suited to the measurement of low resistances, an example is being given below.

Example 8.17. A shunt type ohmmeter uses a 10 mA basic d'Arsonval movement with an internal resistance of 5 Ω . The battery emf is 3 V. It is desired to modify the circuit by adding appropriate shunt resistances across the movement so that its instrument indicates 0.5 Ω at the mid-point on its scale. Calculate (a) the value of shunt resistance (b) Value of current limiting resistor R_1 .

Solution. For half scale deflection

$$I_m = 0.5 I_{fs} = 0.5 \times 10 = 5 \text{ mA.}$$

$$\text{The voltage across the movement} = (5 \times 10^{-3}) \times 5 = 25 \times 10^{-3} = 25 \text{ mV.}$$

(a) Referring to Fig. 8.16.

Voltage across unknown resistor = voltage across movement.

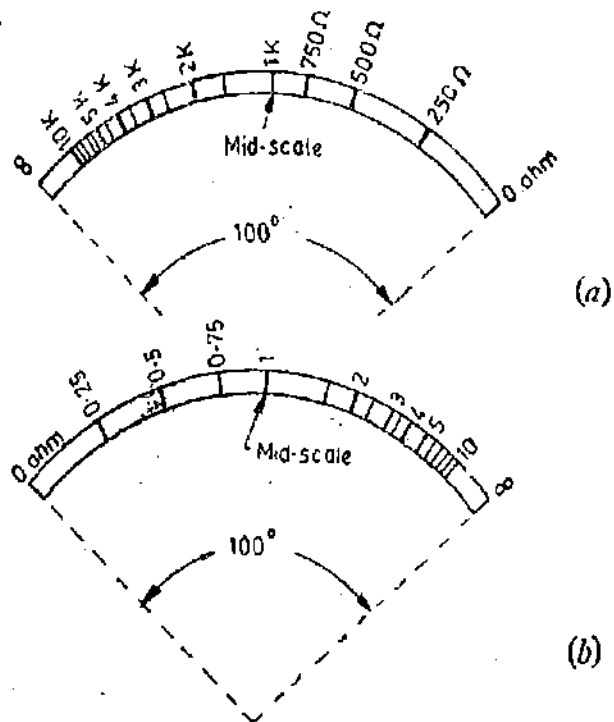

Fig. 8.17. Shape of scale of ohmmeters.
 (a) Series type ohmmeter with a half scale resistance value of 1 k Ω .
 (b) Shunt type ohmmeter with a half scale resistance value of 1 Ω .

∴ Current through unknown resistance $I_x = \frac{25 \times 10^{-3}}{0.5} = 50 \text{ mA}$.

Current through shunt $I_{sh} = I_x - I_m = 50 - 5 = 45 \text{ mA}$.

∴ The value of shunt resistance $R_{sh} = \frac{25 \text{ mV}}{45 \text{ mA}} = \frac{5}{9} \Omega$.

(b) The total battery current $I_1 = I_x + I_m + I_{sh} = 50 + 5 + 45 = 100 \text{ mA}$.

Voltage drop across limiting resistor $= 3 - 25 \times 10^{-3} = 2.975 \text{ V}$ ∴ $R_1 = \frac{2.975}{100 \times 10^{-3}} = 29.75 \Omega$.

Thus by using proper meter and shunts, low values of resistances can be measured.

8.22. Multimeter or Volt-Ohm-Milli-ammeter (V.O.M.) The ammeter, the voltmeter and the ohmmeter all use a basic d'Arsonval movement. The difference between these instruments is the circuit in which the basic movement is used. It is therefore obvious that an instrument can be designed to perform these three measurement functions. This instrument which contains a function switch to connect the appropriate circuits to the d'Arsonval movement, is called a "Multimeter" or "Volt-ohm-milli-ammeter" (V.O.M.).

A representative example of a commercial multimeter is the Simpson model 260 whose complete circuit diagram is shown in Fig. 8'18. The meter is a combination of a d.c. milli-ammeter, a d.c. voltmeter, an a.c. voltmeter, a multirange ohmmeter and an output meter.

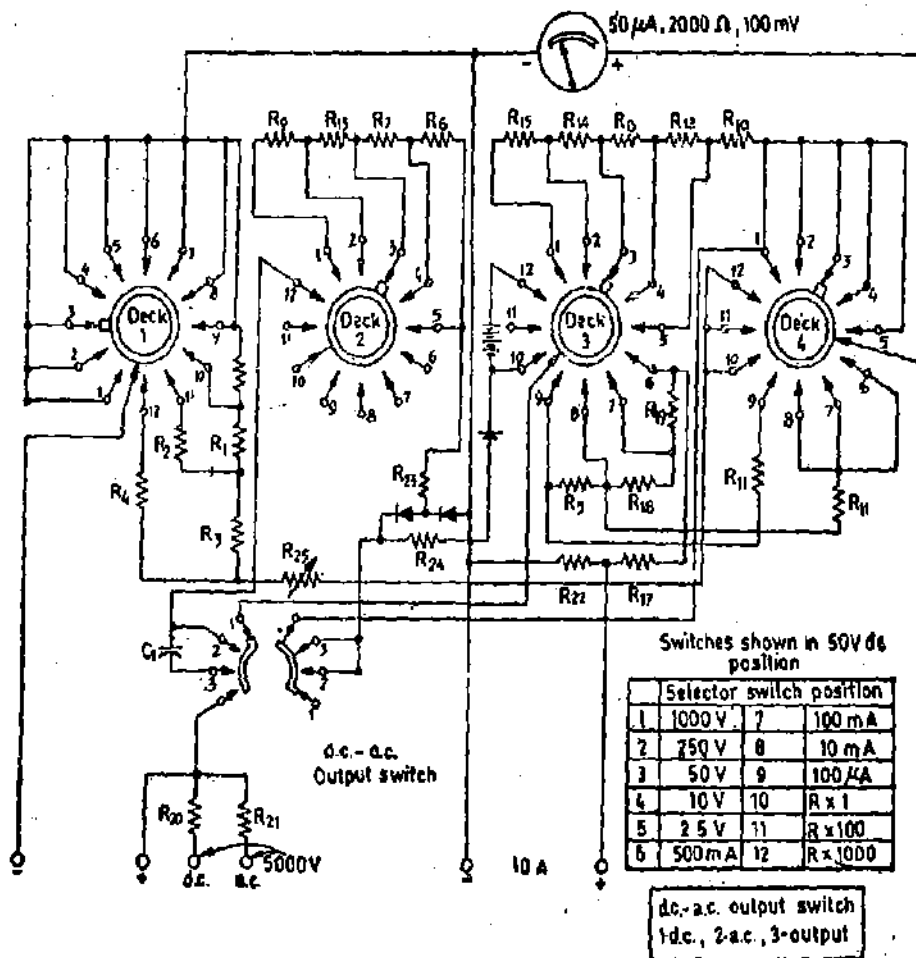

Fig. 8'18. Circuit diagram of Simpson model 260 Multimeter.

This multimeter uses a d'Arsonval movement that has a resistance of 2000 Ω and a full scale current of 50 μA.

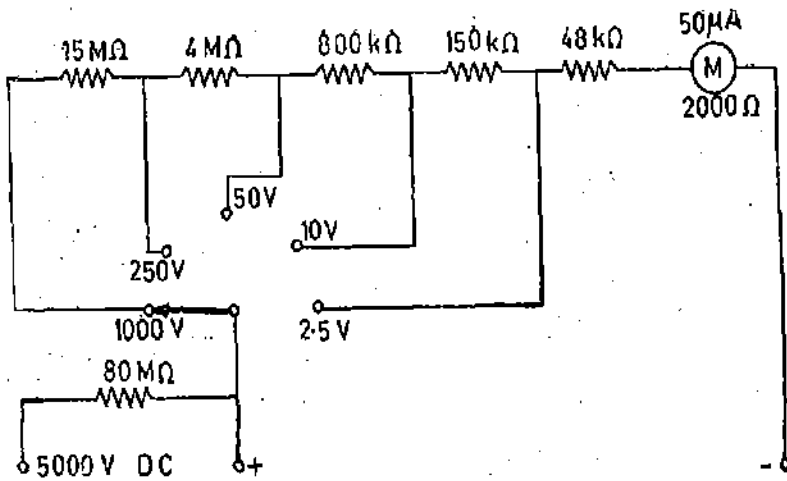

Fig. 8'19. D.C. voltmeter section of Simpson Model 260 Multimeter.

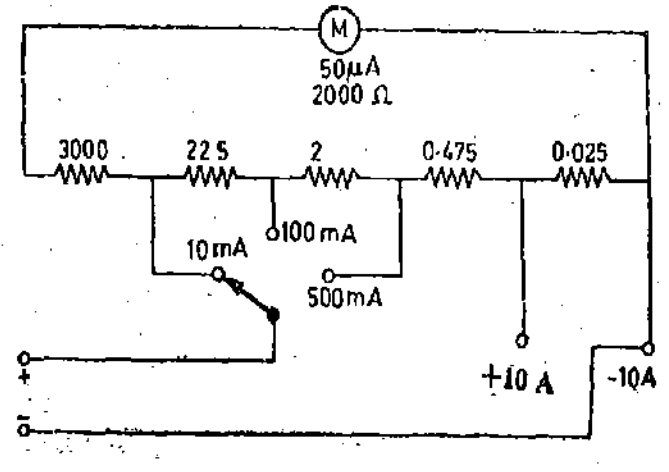

Fig. 8'20. Ammeter section of Simpson Model 260 Multimeter.

The instrument is provided with a selector switch which can be set for different modes of operation like measurement of voltage, current, resistance etc., and also for various ranges of these quantities.

The circuit for d.c. voltmeter section is shown in Fig. 8'19 when common input terminals are used for voltage ranges of 0-1.5 V to 0-1000 V. The range can be set with the help of a selector switch. An external voltage jack marked "DC 5000 V" is used for d.c. voltage measurements upto 5000 V. The values of multiplier resistances are given in Fig. 8'19. For use on 5000 V range, the selector switch should be set to 1000 V position but the test lead should be connected to the external jack marked "5000 V". The instrument has a sensitivity of 20 kΩ/V which is fairly high and therefore the instrument is well suited to general service work in electronic measurements.

The circuit for measuring d.c. milliampere and ampere is shown in Fig. 8'20. The common

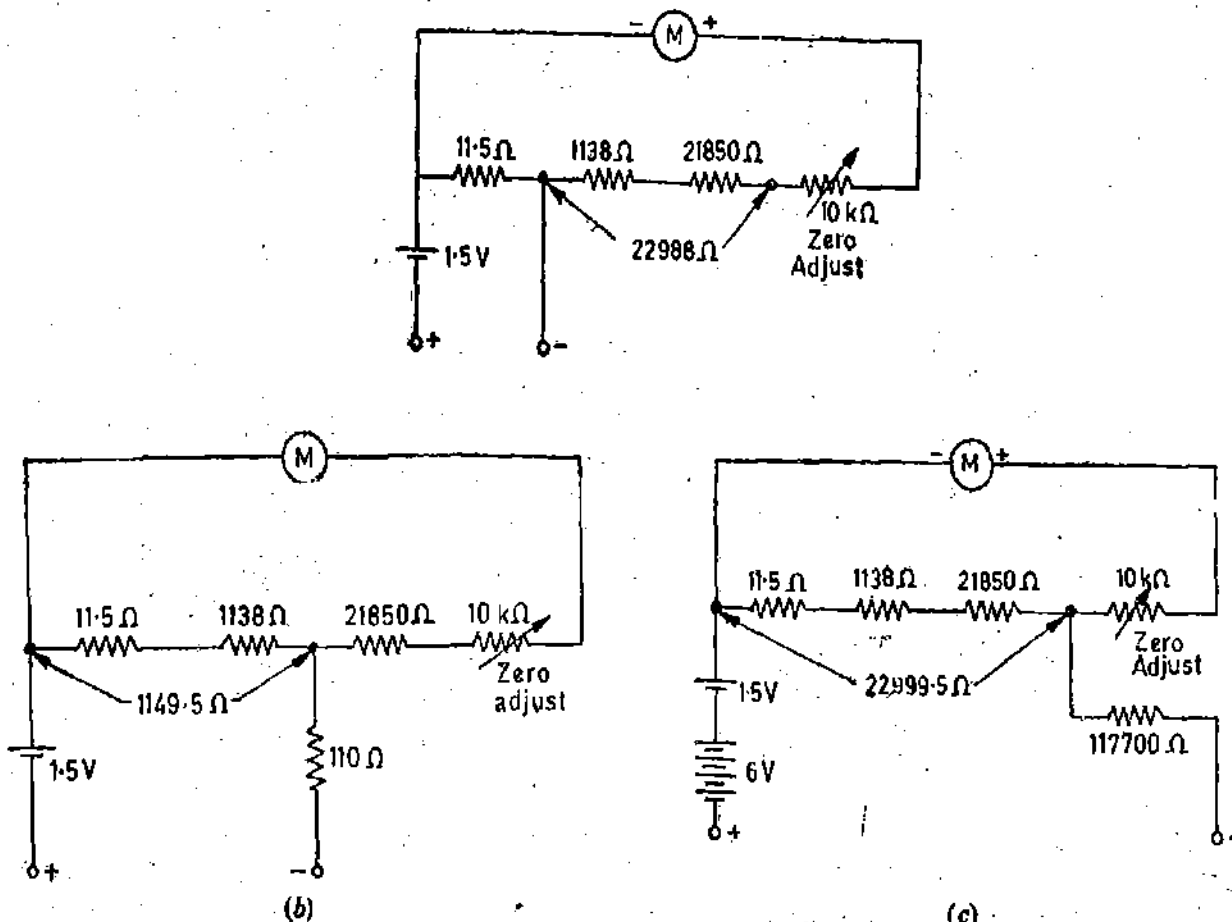

Fig. 8'21. Ohmmeter section of Simpson Model 260 Multimeter (a) $R \times 1$ range (b) $R \times 100$ range (c) $R \times 10,000$ range

(+) terminal and negative (-) terminals are used for current measurements upto 500 mA. The jacks marked +10 A and -10 A are used for 0-10 A range.

The details of the ohmmeter section of the VOM meter are shown in Fig. 8'21. The circuit of Fig. 8'21 (a) shows the ohmmeter circuit for a scale multiplication of 1 i.e. $\times 1$ scale. The instrument is a variation of shunt type ohmmeter. The instrument is short circuited and the zero adjustment Control is varied until the meter reads zero resistance. The circuit a for scale multiplications of 100 and 10,000 are shown in Fig. 8'21 (b) and 8'21 (c). A.C. voltmeter readings are obtained by setting the "a.c.-d.c." switch to the a.c. position. When put on a.c. position, the input is rectified with the help of diodes and then fed to the meter.

8'23. Ratiometer. A permanent magnet ratiometer consists of two moving coils rigidly fixed together and mounted on the same spindle. They move in the magnetic field of a permanent magnet (Fig. 8'22). Current is led to the moving coils with the help of fine ligaments. There are no controlling forces. Let us consider a simple case of two coils mounted 90° apart moving in a parallel field. Let I_1 and I_2 be the currents carried by coil 1 and 2 respectively.

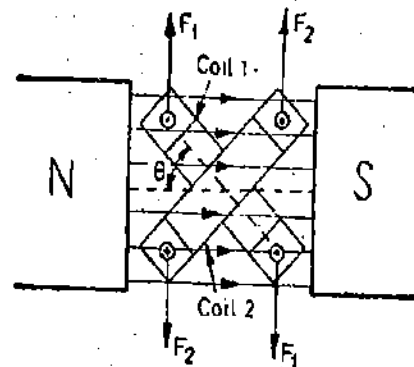

Fig. 8'22, Ratiometer.

Deflecting torque acting on coil 1 : $T_{a1} = N_1 B l_1 d_1 I_1 \cos \theta^*$

This torque acts in the clockwise direction

Deflecting torque acting on coil 2, $T_{a2} = N_2 B l_2 d_2 I_2 \sin \theta^*$.

This torque acts in the anti-clockwise direction. At the equilibrium position, $T_{a1} = T_{a2}$.

or
$$N_1 B l_1 d_1 I_1 \cos \theta = N_2 B l_2 d_2 I_2 \sin \theta$$

or
$$\tan \theta = \frac{N_1 B l_1 d_1}{N_2 B l_2 d_2} \cdot \frac{I_1}{I_2} = k \frac{I_1}{I_2} \dots(8'50)$$

Thus the deflection depends upon the ratio of two currents I_1 and I_2 and hence the name ratiometer.

The shape of the pole faces can be modified and the angle between the two coils can be adjusted which enables the ratio I_1/I_2 to be proportional to the deflection θ instead of $\tan \theta$. For such a meter

$$\theta = k \frac{I_1}{I_2} \dots(8'51)$$

and hence the meter has a linear scale for the ratio I_1/I_2 .

8'24. Ratiometer Ohmmeters. Ratiometer ohmmeters have two forms of construction.

1. Fixed magnet moving coil type. This form of construction consists of a fixed permanent magnet as in most d'Arsonval meters except for the shape of the pole pieces (Fig. 8'23). The moving system consists of two coils mounted on the opposite sides of a common axis. Spirals carry current to and from these coils and spirals must be very flexible in order that they produce a negligible restraining torque on the movement and the deflection of the system is determined by the magnetic forces acting on the two coils. The central iron core is shaped as shown in Fig. 8'23 and mounted off centre so that a tapering non-uniform air gap is produced.

Currents are passed through the coils to produce torques in the opposite directions. If from initial equilibrium, the current in one coil increases relatively to the other, that coil moves to a position having a longer air gap and hence comes under the influence of a lower flux density while the other coil moves to a position of higher flux density. Equilibrium is reached when the two torques are equal. In Fig. 8'23 two resistances R and S connected in the circuit of the two coils are supplied by the same battery. S is a standard and R is the unknown resistance.

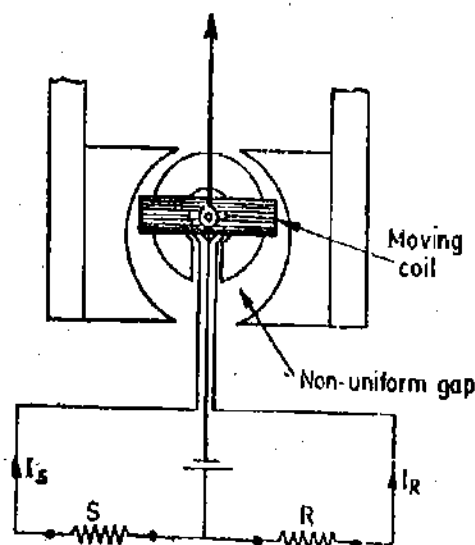

Fig. 8'23. Fixed magnet moving coil ohmmeter.

*This is because the field is not radial but is parallel and therefore we introduce $\cos \theta$ and $\sin \theta$ in the expression.

The deflection of the moving system is a function of the relative magnitude of currents in the two coils-

$$\text{Deflection } \theta = f\left(\frac{I_s}{I_R}\right) = f\left(\frac{E/S}{E/R}\right) = f\left(\frac{R}{S}\right)$$

Thus the scale can be calibrated to read directly the value of unknown resistance R .

An advantage of this circuit is that a change of battery voltage affects both coils in the same proportion and hence does not affect the calibration. It is thus unnecessary to use a regulated power supply or to provide compensation for voltage changes.

2 Crossed Coil Construction. Fig. 8'24 shows a crossed coil ohmmeter. Coil 1 is connected

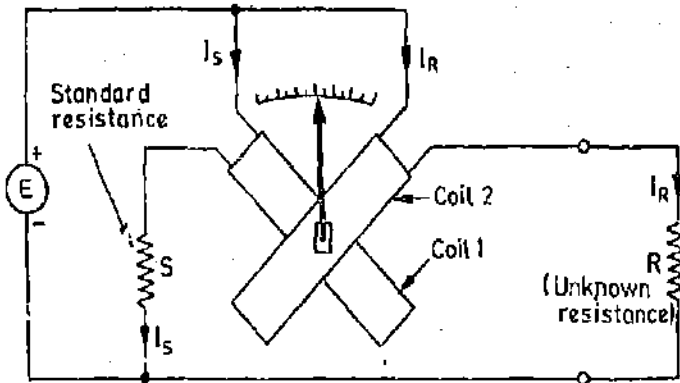

Fig. 8'24. Crossed coil ohmmeter.

in series with the fixed resistor to the power supply, and hence current I_s is proportional to voltage E . Coil 2 carries a current I_R flowing in the unknown resistance R and this current is also proportional to voltage E .

If the pole faces are shaped properly

$$\text{Deflection } \theta = \frac{I_s}{I_R} = \frac{E/S}{E/R} = \frac{R}{S}$$

Since S is fixed the scale of the instrument can be calibrated to read directly the value of unknown resistance R .

8'25. Megger. Ratiometer ohmmeters, described earlier, may be designed to cover a wide range of resistances. The principle of ratiometer ohmmeters is particularly adapted to application in portable instruments measuring insulation resistance. This principle forms the basis of insulation testing instrument known as Megger. The essential parts of a Megger are shown in Fig. 8'25. The current coil is similar to that of the permanent magnet moving coil instrument. There are two voltage (potential) coils V_1 and V_2 . The voltage coil V_1 embraces (threads over) the annular magnetic core. It is clear from Fig. 8'25 that voltage coil V_1 is in a weak magnetic field when the pointer is at ' ∞ ' position and hence this coil can exert very little torque.

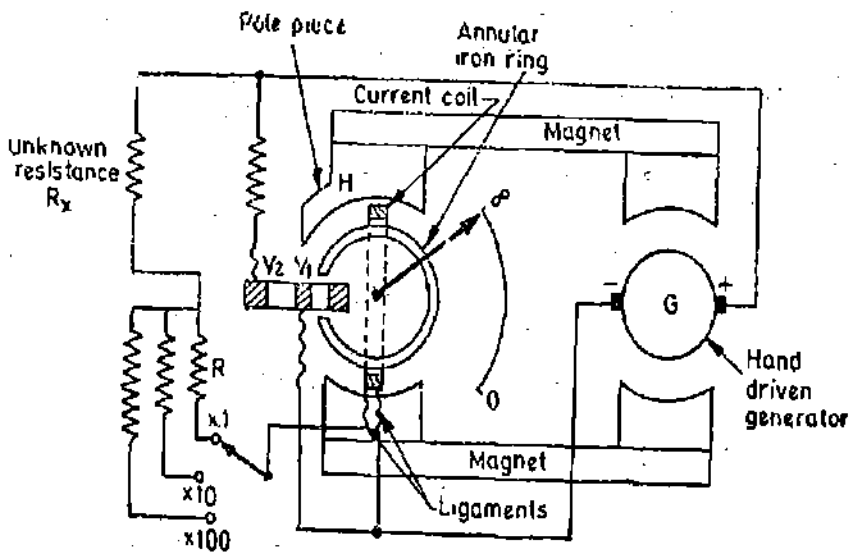

Fig. 8'25. Megger.

The torque exerted by the voltage coil increases as it moves into a stronger field and this torque is maximum when it is under the pole face and under this condition the pointer is at its zero end of the resistance scale. In order to modify further the torque in the voltage circuit, another vol-

tage coil V_2 is used. This coil is also so located that it moves into stronger field as the pointer moves from the ' ∞ ' position towards the zero position of the resistance scale. The coil finally embraces (threads around) the extension H of the pole piece.

The combined action of the two voltage coils V_1 and V_2 may be considered as though the coils constituted a spring of variable stiffness, being very stiff near the zero end of the scale where the current in the current coil is very large (on account of unknown resistance R_x being small), and very weak near the ∞ end of the scale where the current in the current coil is very small (on account of unknown resistance R_x being very large).

Thus this effect compresses the low resistance portion of the scale and opens up the high resistance portion of the scale. This is a great advantage since this instrument is meant to be used as "insulation tester" and the insulation resistances are quite high.

The voltage range of the instrument can be controlled by a voltage selector switch. This can be done by varying resistance ' R ' connected in series with the current coil. The test voltages, usually 500, 1000 or 2500 V are generated by a hand cranked generator G . A centrifugal clutch is incorporated in the generator drive mechanism which slips at a predetermined speed so that a constant voltage is applied to the insulation under test. This voltage provides a test on strength of low voltage insulation as well as a measure of its insulation resistance, since it is sufficient to cause breakdown at faults. Such breakdowns are indicated by sudden motion of the pointer off scale at zero end. As the same magnet system supplies magnetic fields for both instrument and generator, and as current and voltage coils move in a common magnetic field, the instrument indications are independent of the strength of the magnet.

8'26. **Ducter Ohmmeter.** The principle of Ohmmeter can be applied to the measurement of low resistances. The instrument is known as a Ducter and its connections are shown in Fig. 8'26.

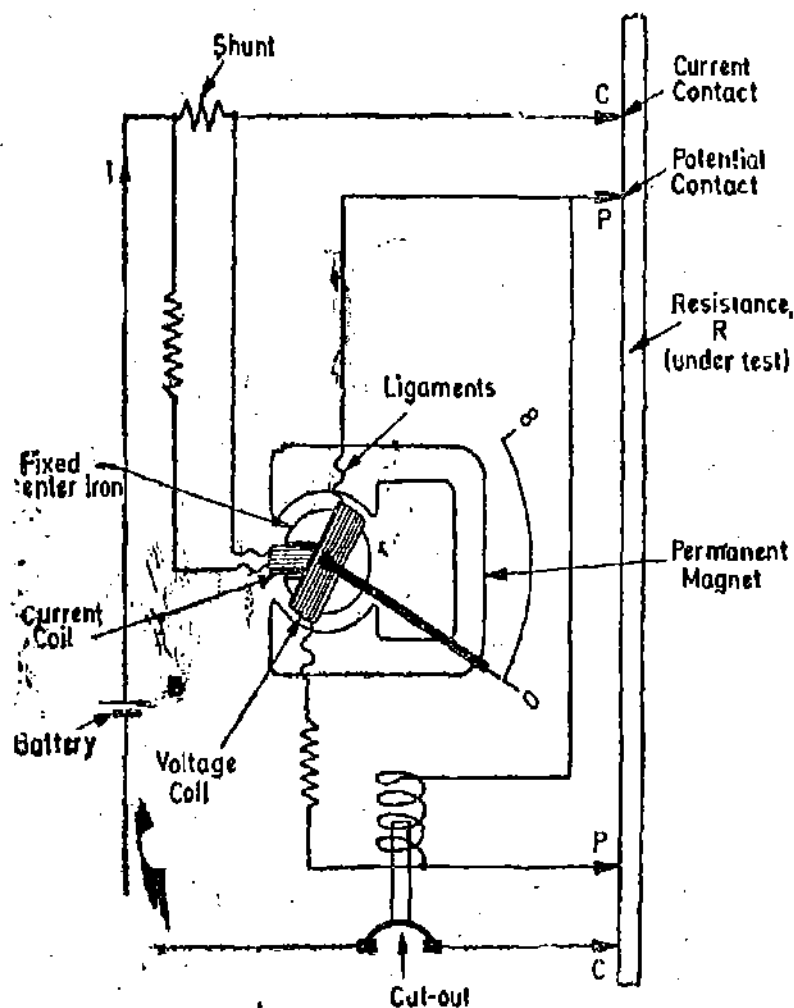

Fig. 8'26. Ducter low resistance ohmmeter.

As in a crossed coil ohmmeter, the two moving coils which are at right angles to each other are free to move in the field of a permanent magnet. Current from a low-voltage supply of about 1.5 V is passed through the four-terminal low resistance under test at the current terminals *CC*. The potential coil is tapped across the potential terminals *PP* of the unknown resistance.

Therefore the current flowing through the voltage coil is proportional to drop between terminals *PP*. This drop is proportional to IR where I is the current flowing and R is the value of unknown resistance. Therefore, torque T_1 acting on voltage coil is proportional to IR . The current coil is connected across a shunt in the main circuit. Therefore, this coil carries a current proportional to the current through resistor R so that the torque T_2 produced by it is proportional to the current I . It is arranged that these torques are in opposition. The moving system, therefore, turns till these two torques are equal.

Thus the position taken up by the moving system is dependent on the ratio of the potential drop and the current through the resistor, i.e., on the value of the resistance under test.

Ducters are made with various full scales ranges from $100 \mu\Omega$ to 5Ω . Different ranges can be obtained by using suitable multipliers.

8.27. Moving Iron Instruments

The most common ammeters and voltmeters for laboratory or switch-board use at power frequencies are the moving iron instruments. These instruments can be constructed to measure current and voltage to the accuracy needed in most engineering works and still be cheap as compared with any other type of a.c. instrument of same accuracy and ruggedness.

A plate or vane of soft iron or of high permeability steel forms the moving element of the system. This iron vane is so situated that it can move in a magnetic field produced by a stationary coil. The coil is excited by the current or voltage under measurement. When the coil is excited, it becomes an electromagnet and the iron vane moves in such a way so as to increase the flux of the electromagnet. This is because the vane tries to occupy a position of minimum reluctance. Thus the force (or torque) produced is always in such a direction as to increase the inductance of the coil (As inductance increases as reluctance decreases).

8.28. General Torque Equation

An expression for the torque of a moving iron instrument may be derived by considering the energy relations when there is a small increment in current supplied to the instrument. When this happens there will be a small deflection $d\theta$ and some mechanical work will be done.

Let T_a = deflecting torque

\therefore Mechanical work done = $T_a \cdot d\theta$

Alongside there will be a change in the energy stored owing to inductance.

Suppose the initial current is I , the instrument inductance L and the deflection θ . If the current increases by dI then the deflection changes by $d\theta$ and the inductance by dL . In order to effect an increment dI in the current there must be an increase in the applied voltage given by

$$e = \frac{d}{dt}(LI) = I \frac{dL}{dt} + L \frac{dI}{dt}$$

The electrical energy supplied $eIdt = I^2 dL + ILdI$

The stored energy changes from $\frac{1}{2}I^2L$ to $\frac{1}{2}(I+dI)^2(L+dL)$.

Hence the change in stored energy $\frac{1}{2}(I^2 + 2IdI + dI^2)(L+dL) - \frac{1}{2}I^2L$.

Neglecting second and higher order terms in small quantities this becomes $ILdI + \frac{1}{2}I^2dL$

From the principle of the conservation of energy,

Electrical energy supplied = increase in stored energy + mechanical work done

$$I^2 dL + ILdI = ILdI + \frac{1}{2}I^2 dL + T_a d\theta$$

Thus

$$T_a d\theta = \frac{1}{2}I^2 dL$$

or Deflecting torque $T_d = \frac{1}{2} I^2 \frac{dL}{d\theta}$... (8'52)

T is in newton-metre, I in ampere, L in henry, and θ in radian.

The moving system is provided with control springs and it turns the deflecting torque T_d is balanced by the controlling torque T_c .

Controlling torque $T_c = K\theta$

where K = control spring constant ; Nm/rad, θ = deflection ; rad.

At equilibrium (or final steady) position, $T_c = T_d$

or $K\theta = \frac{1}{2} I^2 \frac{dL}{d\theta}$ or deflection $\theta = \frac{1}{2} \frac{I^2}{K} \frac{dL}{d\theta}$... (8'53)

Hence the deflection is proportional to square of the rms value of the operating current.

8'29. Classification of Moving Iron Instruments. Moving iron instruments are of two types :

- (i) Attraction type. (ii) Repulsion type.

8'30. Attraction Type. Fig. 8'27 shows the constructional details of an attraction type moving iron instrument. The coil is flat and has a narrow slot like opening. The moving iron is a flat disc or a sector eccentrically mounted. When the current flows through the coil, a magnetic field is produced and the moving iron moves from the weaker field outside the coil to the stronger field inside

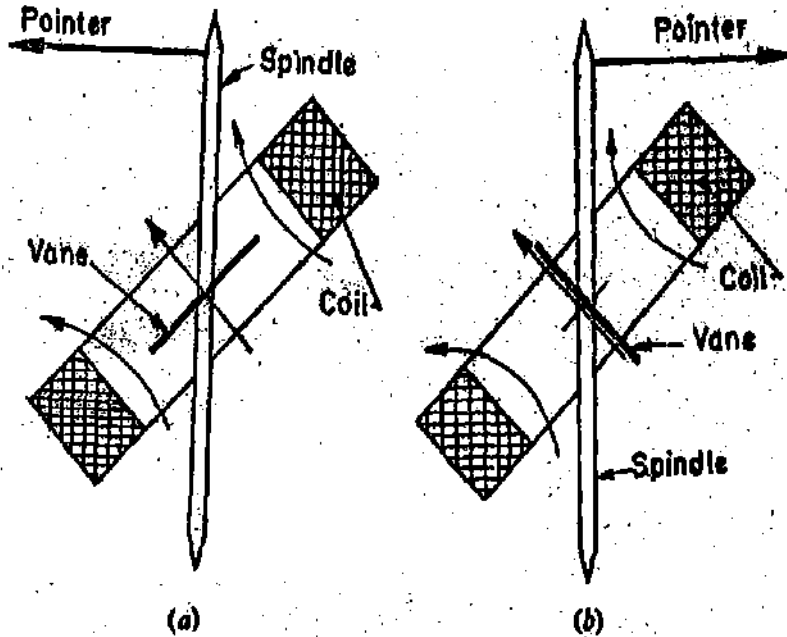
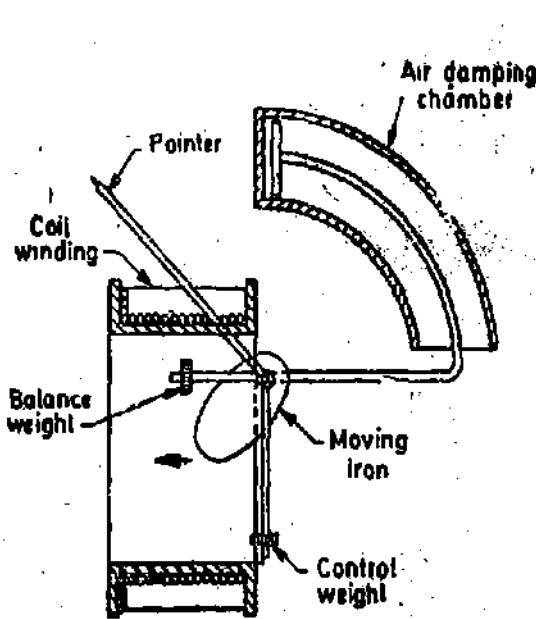

Fig. 8'27. Attraction type moving iron instrument. Fig. 8'28. Thompson inclined coil instrument.

it or the moving iron is attracted in. The controlling torque is provided by springs but gravity control can be used for panel type of instruments which are vertically mounted.

Damping is provided by air friction usually by a vane moving in a sector shaped chamber.

Another type of instrument which can be classed with attraction type is the Thompson inclined coil instrument. The inclined coil instrument (Fig. 8'28) utilizes the tendency of a metal strip to align itself parallel to a magnetic field. In this instrument, the vane is a thin circular iron disc attached at an angle to the spindle of the moving element. The coil surrounds the disc, and its axis is also inclined at an angle to the shaft.

If the coil and the vane were set at an angle of 45° to the axis of the moving system, a total angular displacement of 180° would be necessary to move the vane from position (a) perpendicular to the lines of force, to position (b), parallel to the lines of force.

8'31. Repulsion Type. In the repulsion type, there are two vanes inside the coil one fixed and

other movable. These are similarly magnetised when the current flows through the coil and there is a force of repulsion between the two vanes resulting in the movement of the moving vane.

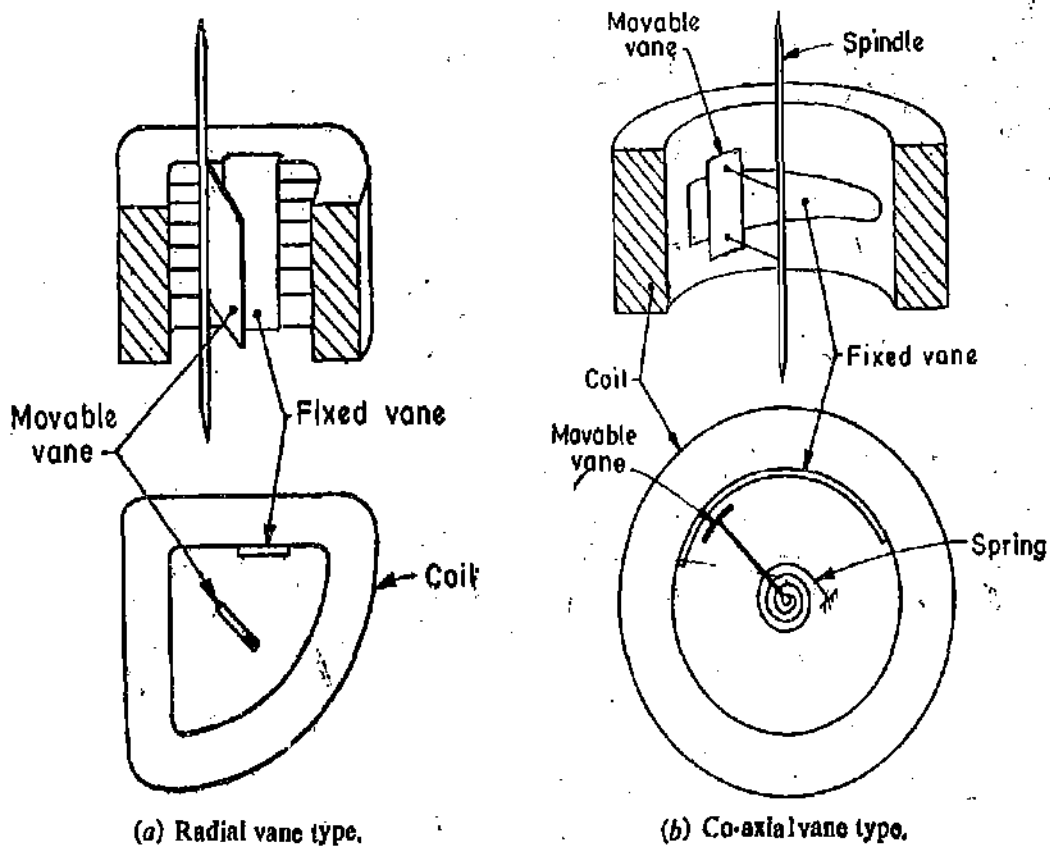

Fig. 8'29. Repulsion type moving iron instruments.

Two different designs are in common use :

(i) *Radial Vane Type.* In this type, the vanes are radial strips of iron. The strips are placed within the coil as shown in Fig. 8'29 (a). The fixed vane is attached to the coil and the movable one to the spindle of the instrument.

(ii) *Co-axial Vane Type.* In this type of instrument, the fixed and moving vanes are sections of co-axial cylinders [See Fig. 8'29 (b)]. The fixed and moving vanes have shapes, similar to those shown in Fig. 8'30, when developed.

8'32. Reason for Use on both A.C. and D.C. It is clear that whatever may be the direction of the current in the coil of the instrument, the iron vanes are so magnetised that there is always a force of attraction in the attraction type and repulsion in the repulsion type of instruments. Thus moving iron instruments are unpolafised instruments i.e., they are independent of the direction in which the current passes. Therefore, these instruments can be used on both a.c. and d.c.

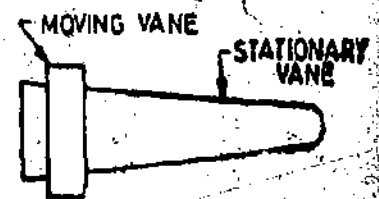

Fig. 8'30. Stationary and moving vanes.

8'33. Shape of Scale. The deflection in a moving iron instrument is given by

$$\theta = \frac{1}{2} \frac{I^2}{K} \frac{dL}{d\theta}$$

Thus the angular deflection is proportional to the square of the operating current, and the instrument has a square law response. The deflection is in terms of rms value of current or voltage. As the deflection is proportional to square of current, it is evident that the scale of such an instrument is non-uniform.

If there is no saturation, the change of inductance with angle of deflection is uniform i.e., $dL/d\theta = \text{a constant}$. For such an instrument, the scale can be easily laid as the measured quantity is proportional to the square root of deflection.

In actual instruments $dL/d\theta$ is not constant and is usually a function of angular position of the moving iron and thus the scale is distorted from the square law in a manner dependent upon the way in which inductance varies with angle. This variation can be controlled by suitable design *i.e.*, by choosing proper dimensions, shape and position of iron vanes. Thus it is possible to design and construct an instrument with a scale which is very nearly uniform over a considerable part of its length. The necessary condition relating to $dL/d\theta$ against θ for linearization may be obtained from Eqn. 8'53 which gives :

$$\frac{dL}{d\theta} = \frac{2K\theta}{I^2}$$

For a linear scale $I = C\theta$ where C is a constant.

$$\frac{dL}{d\theta} = \frac{2K}{C^2\theta} \quad \text{or} \quad \theta \cdot \frac{dL}{d\theta} = \text{constant.}$$

Thus for a linear scale product $\theta \cdot \frac{dL}{d\theta}$ should be a constant.

This is not possible as it requires $dL/d\theta$ to be infinite at $\theta=0$. In practice the scale is made linear from the maximum deflection down to about 1/10th of the maximum deflection. The plot of $dL/d\theta$ against θ over the range is a rectangular hyperbola as shown in Fig. 8'31.

It is also possible to design and construct an instrument in which a small portion of the range, which is of particular interest or importance, is expanded over a large part while the remainder of the scale is compressed into a relatively small space. It is clear from the torque equation (Eqn. 8'53) that the portion of scale near zero can never be expanded or made uniform since this would require that the initial value of $dL/d\theta$ be infinite.

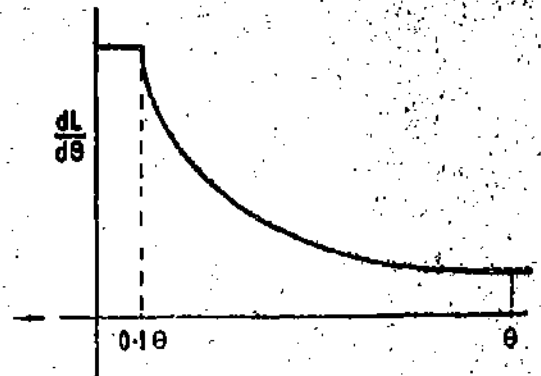

Fig. 8'31. Variation of $dL/d\theta$ v/s. θ .

The deflecting torque is proportional to the square of current multiplied by the rate of change of inductance with angle. The scale is compressed at its lower end because I^2 is small relative to full scale value and somewhat compressed at its higher end because in this range the rate of change of inductance with angle (*i.e.*, $dL/d\theta$) decreases rapidly (See Fig. 8'31). The scale is usable over about 80° of its length.

The scale distribution in the case of radial vane repulsion type instruments can be explained in the following way.

As the induced pole strengths of the magnetised vanes is proportional to the current in the coil, the force between them (proportional to product of pole strengths) should vary as the square of the coil current. However, as the distance between them the vanes increases, the force decreases as it (force) is inversely proportional to the square of this distance. These effects tend to neutralize each other and, as a result, the instrument scale is very nearly uniform over most of its length.

In the case of coaxial cylinder type repulsion instruments, the scale distribution can be made similar to that radial vane type by tapering the fixed vane.

8'34. Long Scale Instruments. The attraction and repulsion type moving iron instruments are limited in practical designs to deflections of approximately 90°. However, by combining the two types of operation, it is possible to design an instrument which has good torque characteristics and scale distribution over an angle of 240° or more giving a circular scale.

The construction of this instrument, which employs a combination of attraction and repulsion forces, is shown in Fig. 8'32. It is clear that over the first part of the scale the vane is repelled by the stationary middle vane, which is wide in this region. As the deflection increases, the outer stationary vanes exert attractive force on the moving vane and add to the torque. By suitably shaping the vanes the scale distribution may be controlled so that it is useful over about 240°.

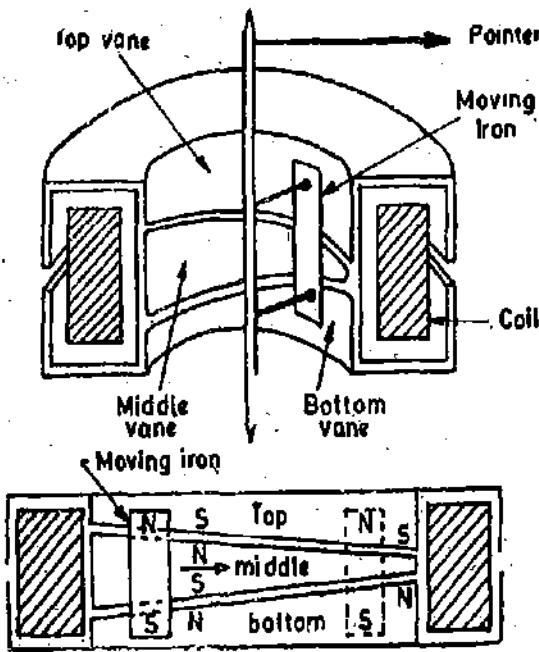

Fig. 8'32. Long range instrument.

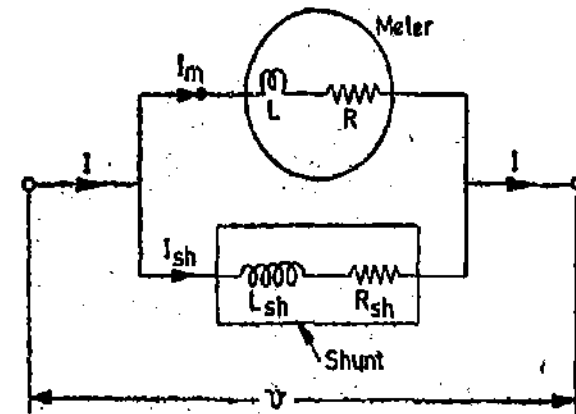

Fig. 8'33. Shunt for moving iron instrument.

8'35. Shunt for Moving Iron Instruments. Moving iron instruments can be built for a range upto 50 A since in these instruments moving parts do not carry any current. Hence shunts are not necessary, except for very large currents. However, if a shunt is required to be used with an ammeter to extend its range, the inductances of both the meter coil and the shunt must be considered along with their resistances.

Fig. 8'33 shows a shunt placed in parallel with a moving iron instrument. The currents in meter and shunt are in inverse ratio of their impedances.

$$\text{or } \frac{I_{sh}}{I_m} = \sqrt{\frac{(R)^2 + (\omega L)^2}{(R_{sh})^2 + (\omega L_{sh})^2}} = \frac{R_{sh} \sqrt{1 + (\omega L/R)^2}}{R \sqrt{1 + (\omega L_{sh}/R_{sh})^2}} \quad \dots(8'54)$$

It is clear from above that the ratio of two currents depends upon frequency.

In order that the division of current through two parallel branches—meter and the shunt—shall remain the same for all frequencies, the ratio of impedances of two branches must remain constant. It is clear from Eqn. 8'54 that in order to fulfil this condition L_{sh}/R_{sh} must be equal to L/R . or in other words the time constants of meter and shunt should be the same. If $L_{sh}/R_{sh} = L/R$.

$$\frac{I_{sh}}{I_m} = \frac{R_m}{R_{sh}} \quad \dots(8'55)$$

We have seen that in order to make readings independent of the frequency the time constants of meter and shunt should be equal. But it is difficult to design a shunt with appropriate inductance, and shunts are rarely incorporated in moving iron ammeters. It has already been mentioned that the coils can be wound to carry the whole current for ranges up to about 50 A, so that, in fact, shunts are normally not required. Current transformers may be used for ranges above 50 A. Multi-range moving iron instruments may be designed by winding the instrument coil sections and various ranges may be obtained by connecting the different sections in series, parallel or series parallel combinations.

Incidentally the multiplying power of a shunt with $L_{sh}/R_{sh} = L/R$ is :

$$m = 1 + R/R_{sh} \quad \dots(8'56)$$

8'36. Multipliers for Moving Iron Instruments. As in d.c. permanent magnet moving-coil instruments, the voltage range of moving-iron instruments may be extended by the use of a series resistance (multiplier) with the working-coil as shown in Fig. 8'34. For operation on a.c. where frequency is likely to change, it is necessary that the total impedance of the voltmeter circuit (series resistance plus impedance of the working coil) should remain substantially constant over a large frequency range. Since the series resistance forms a major portion of the total impedance of the voltmeter circuit, it is desirable that this resistor should be either of non-inductive type or have as small an inductance as possible. For this reason, the resistance coils for use with voltmeter circuits are usually wound on flat mica strips. This reduces the area enclosed by the turns of wire, and hence the flux for a given current. For this purpose sometimes non-inductively woven gauze resistors are used. In this way the total inductance in the voltmeter is practically confined to the working coil itself and because the series resistance of the circuit is large, this is likely to swamp the variations of inductive reactance of the working coil with the change in frequency.

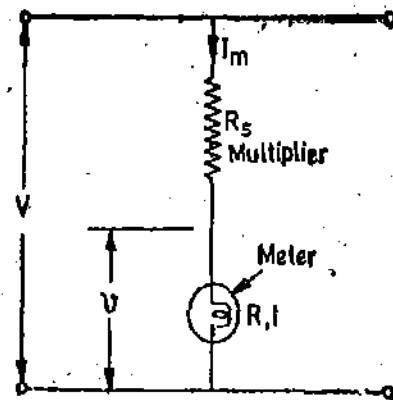

Fig. 8'34./ Voltage multiplies for moving iron instruments.

Let R = resistance of meter, L = inductance of meter,

I_m = meter current for full scale deflection ω = angular frequency.

Voltage drop across the meter for full scale deflection $v = I_m \sqrt{R^2 + \omega^2 L^2}$

Let V be the voltage to be measured and R_s be the resistance of the non-inductive multiplier (series resistance).

Then total resistance of circuit = $R + R_s$ and Total inductance of circuit = L

\therefore Total impedance of circuit = $\sqrt{(R + R_s)^2 + \omega^2 L^2}$

and the current in the meter. $I_m = \frac{V}{\sqrt{(R + R_s)^2 + \omega^2 L^2}}$ or $V = I_m \sqrt{(R + R_s)^2 + \omega^2 L^2}$.

Hence, voltage multiplying power $m = \frac{V}{v} = \frac{\sqrt{(R + R_s)^2 + \omega^2 L^2}}{\sqrt{R^2 + \omega^2 L^2}}$... (8'57)

It is evident from Eqn. 8'57 that the multiplying power will change with change in frequency. The multiplier may be shunted by a capacitor, in order to compensate for frequency errors in the voltmeter. This aspect has been explained later in Art. 8'38.

8'37. Comparison between Attraction and Repulsion Types of Instruments. In general it may be said that attraction-type instruments possess the same advantages, and are subject to the limitations, described for the repulsion type. An attraction instrument will usually have a lower inductance than the corresponding repulsion instrument, and voltmeters will therefore be accurate over a wider range of frequency and there is a greater possibility of using shunts with ammeters. On the other hand, repulsion instruments are more suitable for economical production in manufacture, and a nearly uniform scale is more easily obtained; they are, therefore, much more common than the attraction type.

8'38. Errors. There are two types of errors which occur in moving iron instruments—errors which occur with both a.c. and d.c. and the other which occur only with a.c. only.

Errors with both D.C. and A.C.

(1) **Hysteresis Error.** This error occurs as the value of flux density is different for the same current when ascending and descending. The value of flux density is higher for descending

values of current and, therefore, the instrument tends to read higher for descending values of current (and voltage) than for ascending values. This error can be minimized by making the iron parts small so that they demagnetize themselves quickly. Another method is to work the iron parts at low values of flux density so that the hysteresis effects are small.

Hysteresis may produce a 2 to 3 percent error. With the use of nickel iron alloys with narrow hysteresis loops, the error may be brought down to less than 0.05 per cent.

(ii) *Temperature Error.* The effect of temperature changes on moving iron instruments arises chiefly from the temperature coefficient of spring. The error may be 0.02 percent per °C. In voltmeters, errors are caused due to self-heating of coil and series resistance. The temperature of the coil may increase by 10 to 20 °C for a power consumption of 1W. Therefore, the resistance increases (by about 4 to 8%), causing a decrease in current for a given voltage. This produces a decreased deflection. Therefore, the series resistance should be made of a material like Manganin which has a small temperature co-efficient. The value of series resistance should be very large as compared with the coil resistance in order to minimize errors due to self-heating. In the case of switch board instruments, the series resistance is about 10 times the coil resistance.

(iii) *Stray Magnetic Fields.* The errors due to stray magnetic fields (fields other than the operating magnetic field) may be appreciable as the operating magnetic field is weak (about 0.006 to 0.0075 Wb/m² at full scale deflection) and hence can be easily distorted. Such errors depend upon the direction of the stray magnetic field relative to the field of the instrument. These errors can be minimized by using an iron case or a thin iron shield over the working parts.

Since some types of instruments are not shielded, we should be careful in selecting instruments for places where stray magnetic fields are encountered. If we use an unshielded instrument over a table having metal top or mount such instruments on steel panel, the accuracy may be drastically impaired.

Errors with A.C. only

(i) *Frequency Errors.* Changes in frequency may cause errors due to changes of reactance of the working coil and also due to changes of magnitude of eddy currents set up in the metal parts of instrument.

Reactance of Instrument Coil. The change of reactance of the instrument coil is important in case of voltmeters where an additional resistance R_s is used in series with the instrument coil. Let the resistance and inductance of the instrument coil be R and L . Then the current I in the instrument coil for a given applied voltage V is given by :

$$I = \frac{V}{\sqrt{(R+R_s)^2 + \omega^2 L^2}}$$

The deflection of the moving-iron voltmeter depends upon the current through the coil. Therefore, the deflection for a given voltage will be less at high frequencies than at low frequencies. To some extent, compensation to this type of error is possible by connecting a capacitor C across the series resistance R_s as shown in Fig. 8.35.

The idea of shunting the series resistor is to make the circuit behave like a pure resistance so that the frequency changes have no effect on the readings of the instrument. Thus the compensated instrument will have a power factor nearly equal to unity. As the resistance of the meter, R , is considerably smaller than the series multiplier resistance R_s , it can be assumed that it is sufficient to ensure that the magnitude Z of the impedance of the circuit formed by L , R_s , and C has a value R_s under a.c. conditions.

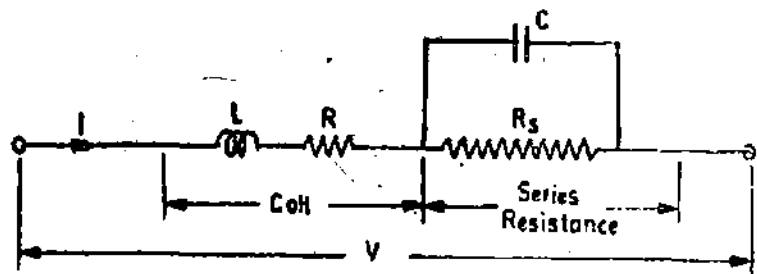

Fig. 8.35. Frequency compensation for M.I. voltmeters.

Now
$$Z = j\omega L + \frac{R_s}{1 + j\omega CR_s} = j\omega L + \frac{R_s - j\omega CR_s^2}{1 + \omega^2 C^2 R_s^2}$$

Since $\omega CR_s \ll 1$, we can write
$$Z = j\omega L + (R_s - j\omega CR_s^2)(1 - \omega^2 C^2 R_s^2)$$

$$= j\omega L + R_s - j\omega CR_s^2 - \omega^2 C^2 R_s^3 + j\omega^3 C^2 R_s^4 = R_s - \omega^2 C^2 R_s^3 + j[\omega L - \omega CR_s^2(1 - \omega^2 C^2 R_s^2)]$$

$$\approx R_s - \omega^2 C^2 R_s^3 + j[\omega L + \omega CR_s^2] = R_s(1 - \omega^2 C^2 R_s^2) + j[\omega L - \omega CR_s^2]$$

Magnitude of Z^2 , $Z^2 = R_s^2(1 + \omega^2 C^2 R_s^2)^2 + \omega^2(L - CR_s^2)^2$

This must equal R_s^2 in order that the a.c. calibration at all frequencies and d.c. calibration is the same.

$$\therefore R_s^2 = R_s^2(1 - \omega^2 C^2 R_s^2)^2 + \omega^2(L - CR_s^2)^2 = R_s^2(1 + \omega^2 C^4 R_s^4 - 2\omega^2 C^2 R_s^2) + \omega^2(L - CR_s^2)^2$$

$$= R_s^2(1 - 2\omega^2 C^2 R_s^2 + \omega^4 C^4 R_s^4) + \omega^2(L - CR_s^2)^2 = R_s^2(1 - 2\omega^2 C^2 R_s^2) + \omega^2(L - CR_s^2)^2$$
 as $\omega^4 C^4 R_s^2 \ll 1$

$$= R_s^2 - 2\omega^2 C^2 R_s^4 + \omega^2 L^2 + \omega^2 C^2 R_s^4 - 2\omega^2 LCR_s^2$$
. Thus $0 = \omega^2 L^2 - \omega^2 C^2 R_s^4 - 2\omega^2 LCR_s^2$

or $L^2 - 2LCR_s^2 - C^2 R_s^4 = 0$ or $L = \frac{2CR_s^2 + \sqrt{4C^2 R_s^4 + 4C^2 R_s^4}}{2}$

$$= 2.41 CR_s^2$$
 or $C = \frac{1}{2.41} \frac{L}{R_s^2}$... (8'58)

In practice it is usual to consider the variation of Z within certain limits for the d.c. value $R + R_s$. Fig. 8'36 shows the frequency error with and without compensation.

It may be observed that for an uncompensated instrument the error goes beyond permissible limits for frequencies above ω_1 . With compensation the frequency range is extended from ω_1 to ω_2 and in fact the instrument current at a frequency ω_3 is the same as with d.c.

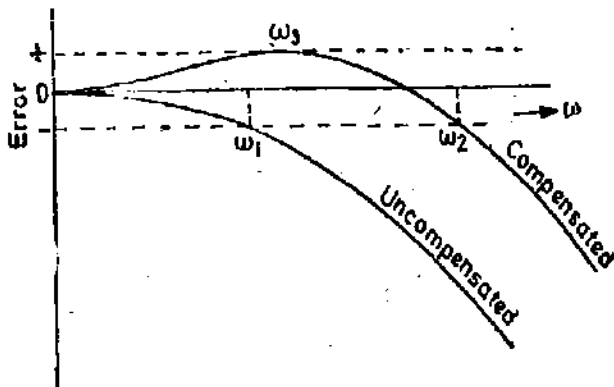

Fig. 8'36. Variation of error with frequency.

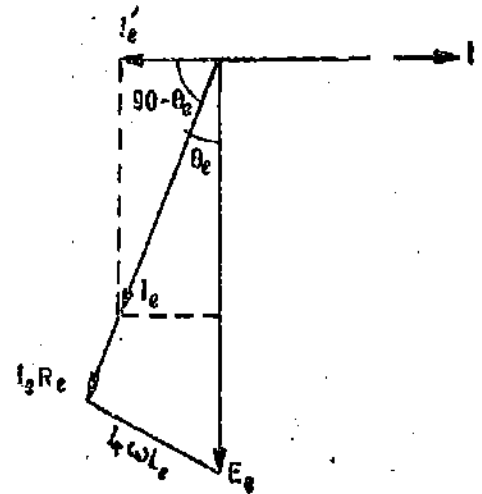

Fig. 8'37. Effect of eddy currents.

Eddy Currents : These errors are caused by eddy currents induced in the iron parts of the instruments. Let the mutual inductance between the instrument coil and the iron parts be M . The induced voltage $E_e (= \omega MI)$ due to current I in the instrument coil lags the current by 90° , (see Fig. 8'37). As a result of this induced voltage an eddy current I_e flows and its magnitude is

$$I_e = \frac{\omega MI}{\sqrt{R_e^2 + \omega^2 L_e^2}}$$

where R_e and L_e are respectively the resistance and inductance of this eddy current path. I_e lags E_e by an angle $\theta_e = \tan^{-1} \frac{\omega L_e}{R_e}$.

A component of this current $I_e' = I_e \cos(90 - \theta_e) = I_e \sin \theta_e$ opposes the instrument current I and sets up an opposing field thus reducing the torque on the moving system. From the phasor diagram sketched in Fig. 8'37, it is seen

$$I_e' = I_e \sin \theta_e = \frac{\omega MI}{\sqrt{R_e^2 + \omega^2 L_e^2}} \cdot \frac{\omega L_e}{\sqrt{R_e^2 + \omega^2 L_e^2}}$$

$$= \frac{\omega^2 M L_e I}{R_e^2 + \omega^2 L_e^2}$$

$$\therefore I_e' = \frac{\omega^2 M L_e I}{R_e^2} \text{ when } R_e \gg \omega L_e, \text{ i.e., when } \omega \text{ is small.}$$

$$I_e' \approx \frac{MI}{L_e} \text{ when } \omega L_e \gg R_e \text{ i.e., when } \omega \text{ is large.}$$

Thus at low frequencies the eddy current error increases with square of the frequency while at high frequencies the error is practically constant. For these reasons moving iron instruments are unsuitable for frequencies above 100 Hz.

In order to extend the frequency range of the instrument, another coil, coupled with the coil of the instrument and loaded by an a.c. network, is used. The frequency error due to eddy currents can be kept less than 0.1% upto a frequency range of 1000 Hz.

8'39. Advantages and Disadvantages

- (1) *Universal Use.* These instruments can be used for both a.c. and d.c.
- (2) *Less Friction Errors.* Errors due to friction are quite small as torque-weight ratio is quite high in these instruments.
- (3) *Cheapness;* Depending upon the magnitude of the current to be measured, the coil may have a few turns of very heavy section conductor or many turns of fine wire so that the total mmf required is the same for a given displacement of the moving system irrespective of the instrument range. Hence identical moving systems may be used for an entire series of instruments from voltmeters which require a small value of current, to the highest range ammeters. Thus in a series of instruments which use an mmf of 200 A at full scale, the highest range ammeter could be for 200 A using one turn while voltmeters of the series could require 50 mA with 4000 turns for full scale deflection. The fact that a single type of moving element could cover the entire range is one reason that moving iron instruments can be built at less cost than some other types.
- (4) *Robustness;* The instruments are robust owing to simple construction and also that there are no current carrying moving parts.
- (5) *Accuracy.* These instruments are capable of giving an accuracy within the limits of both precision and industrial grades. Modern well designed portable moving iron instruments are expected to have a d.c. error of 2 percent or less. The initial accuracy of high grade instruments is stated to be 0.75 percent for frequencies between 25 to 135 Hz and they may be expected to be accurate within 0.2% to 0.3% at 50 Hz if carefully designed.
- (6) *Scale.* Moving iron instruments are now available with 240° circular scales. The greatly increased scale length being a certain advantage. The scale of moving iron instruments is not uniform and is cramped at the lower end and therefore accurate readings are not possible at this end.
- (7) *Errors.* These instruments are subjected to serious errors due to hysteresis, frequency changes and stray magnetic fields.
- (8) *Waveform errors.* The non-linearity of $B-H$ curve of iron means that the deflecting torque is not exactly proportional to the square of the current. Thus, while the theory already given shows that the instrument, once calibrated in rms values, should indicate rms values whatever the waveform will not, in fact, be realized in practice.

However the precision grade instruments are so designed that the maximum flux density reached in the vanes is about 30 to 40% of the saturation value. Hence even alternating currents having highly distorted waveforms can be measured satisfactorily. This is not true of switch-board

instruments where maximum flux density reaches the saturation value. This is done in order to get a large deflecting torque.

(9) *Difference between d.c. and a.c. Calibrations.* There is a difference between d.c. and a.c. calibrations on account of effect of inductance of the meter and the eddy currents when the meter is used on a.c. However, there is another aspect which needs consideration.

When these instruments operate at the lower end of the magnetization curve, the permeability of the iron increases with an increase of current. Therefore peaks of alternating currents produce greater displacement per unit current than the average value. As a result, the meter reading is higher than the d.c. reading at the lower end of the scale. For the larger readings, the iron approaches the knee portion of the $B-H$ curve, the permeability decreases with increase in current, the peaks of a.c. produce less deflection per unit current, and the alternating current reads lower than the equivalent value of d.c.

Thus, although these instruments read direct current, they cannot be calibrated with d.c. and used on a.c. They must be calibrated for frequencies at which they are used.

Example 8.18. The inductance of a moving iron instrument is given by :

$$L = (10 + 5\theta - \theta^2) \mu\text{H}$$

where θ is the deflection in radian from zero position. The spring constant is 12×10^{-6} Nm/rad. Estimate the deflection for a current of 5A.

Solution : Rate of change of inductance with deflection

$$\frac{dL}{d\theta} = \frac{d}{d\theta} (10 + 5\theta - \theta^2) = 5 - 2\theta \mu\text{H/rad}$$

From Eqn. 8.53, the deflection is : $\theta = \frac{1}{2} \frac{I^2}{K} \frac{dL}{d\theta}$

$$\text{or } \theta = \frac{1}{2} \times \frac{(5)^2}{12 \times 10^{-6}} \times (5 - 2\theta) \times 10^{-6}$$

From above, we get $\theta = 1.69 \text{ rad} = 96.8^\circ$.

Example 8.19. The inductance of a moving iron ammeter with a full scale deflection of 90° at 1.5 A, is given by the expression $L = (200 + 40\theta - 4\theta^2 - \theta^3) \mu\text{H}$, where θ is the deflection in radian from the zero position. Estimate the angular deflection of the pointer for a current of 1.0 A.

Solution. Inductance $L = 200 + 40\theta - 4\theta^2 - \theta^3 \mu\text{H}$.

\therefore Rate of change of inductance, with deflection $\frac{dL}{d\theta} = 40 - 8\theta - 3\theta^2 \mu\text{H/rad}$.

$$\frac{dL}{d\theta} \text{ for } \theta = \pi/2 \text{ is : } 40 - 8 \times \frac{\pi}{2} - 3 \left(\frac{\pi}{2} \right)^2 = 20 \mu\text{H/rad.}$$

$$\text{Deflection } \theta = \frac{1}{2} \frac{I^2}{K} \frac{dL}{d\theta}$$

With $I = 1.5 \text{ A}$, we have $\theta = \pi/2$ and $\frac{dL}{d\theta} = 20 \times 10^{-6} \text{ H/rad}$.

Substituting these values in expression for θ we get : $\frac{\pi}{2} = \frac{1}{2} \frac{(1.5)^2}{K} 20 \times 10^{-6}$

\therefore Spring constant $K = 14.3 \times 10^{-6} \text{ Nm/rad}$.

For $I=1$ A

$$\text{Deflection } \theta = \frac{1}{2} \times \frac{(1)^2}{14.3 \times 10^{-8}} (40 - 8\theta - 3\theta^2) \times 10^{-6}$$

From above, we get, $3\theta^2 + 36.6\theta - 40 = 0$ or $\theta = 1.01$ rad. $= 57.8^\circ$.

Example 8.20. The law of deflection of a moving iron ammeter is given by $I=4\theta^n$ ampere where θ is the deflection in radian and n is a constant. The self-inductance when the meter current is zero is 10 mH. The spring constant is 0.16 N-m/rad.

(i) Determine an expression for self-inductance of the meter as a function of θ and n .

(ii) With $n=0.75$ calculate the meter current and the deflection that corresponds to a self-inductance of 60 mH.

Solution. From Eqn. 8.53, deflection in radian $\theta = \frac{1}{2} \frac{I^2}{K} \frac{dL}{d\theta}$

$$\text{Rate of change of self inductance } \frac{dL}{d\theta} = \frac{2K\theta}{I^2} \quad \text{or} \quad dL = \frac{2K}{I^2} \theta d\theta$$

Substituting the value $I=4\theta^n$ in the above expression, we have

$$dL = \frac{2K}{(4\theta^n)^2} \theta d\theta = \frac{1}{8} K\theta^{1-2n} d\theta$$

Integrating the above expression, we have :

$$L = \frac{K\theta^{2-2n}}{8(2-2n)} + A = \frac{K}{16(1-n)} \theta^{2-2n} + A$$

where $A = \text{constant of integration.}$

We have $I=4\theta^n$. Thus $\theta=0$ when $I=0$. It is given that when $I=0$ the value of self-inductance $L=10 \times 10^{-3}$ H.

Putting this in expression for L , $10 \times 10^{-3} = 0 + A$ or $A = 10 \times 10^{-3}$.

Hence the expression for self-inductance as a function of θ and n is :

$$L = \frac{K}{16(1-n)} \theta^{2-2n} + 10 \times 10^{-3} = \frac{1}{100(1-n)} \theta^{2-2n} + 10 \times 10^{-3} \text{ H.}$$

as $K=0.16$

(ii) With $n=0.75$, the expression for self-inductance is :

$$L = \frac{1}{100(1-0.75)} \theta^{2-2 \times 0.75} + 10 \times 10^{-3} = 0.04 \theta^{0.5} + 10 \times 10^{-3} \text{ H.}$$

Putting $L=60 \times 10^{-3}$, we have $60 \times 10^{-3} = 0.04 \theta^{0.5} + 10 \times 10^{-3}$

\therefore Deflection $\theta = 1.56$ rad. $= 89.5^\circ$.

Current $I = 4\theta^n = 4 \times 1.56^{0.75} = 5.51$ A.

Example 8.21. The following figures give the relation between deflection and inductance of a moving iron instrument.

Deflection, degree	20	30	40	50	60	70	80	90
Inductance, μH	335	345	355.5	366.5	376.5	385	391.2	396

Find the current and the torque to give a deflection of (a) 30°, (b) 80°. Given that control spring constant is 0.4×10^{-6} Nm/deg.

Solution. The graph between deflection and inductance is plotted as shown in Fig. 8'38.

The expression for deflection is

$$\theta = \frac{1}{2K} I^2 \frac{dL}{d\theta}$$

Thus in order to find out current I for a particular deflection, we must evaluate $\frac{dL}{d\theta}$ at the deflection concerned.

(a) $\theta = 30^\circ$,

The curve is linear in this region

$$\therefore \left(\frac{dL}{d\theta} \right)_{30} = \frac{355.5 - 335}{40 - 20} = 1.025 \mu\text{H/degree} \\ = 58.6 \mu\text{H/rad.}$$

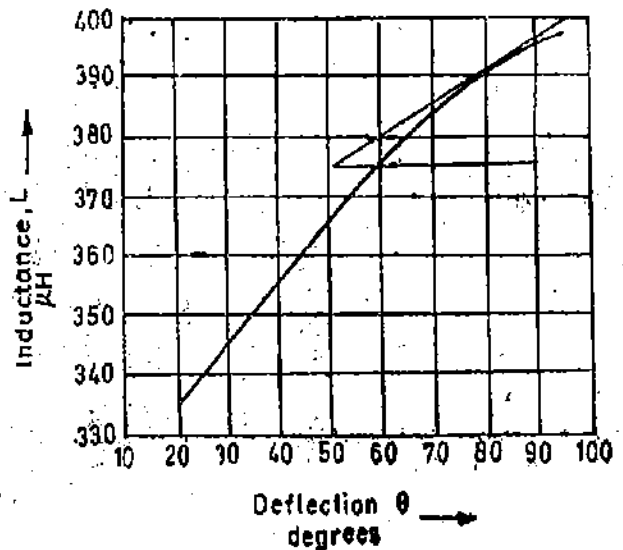

Fig. 8'38

Putting this value in the expression for θ , $30 = \frac{1}{2} \times \frac{1}{0.4 \times 10^{-6}} \times I^2 \times 58.6 \times 10^{-6}$,

or $I = 0.65 \text{ A.}$

(We should express θ in degrees as the value of K is expressed N-m/degree).

Deflecting torque $T_d = T_c = K\theta = 0.4 \times 10^{-6} \times 30 = 12 \times 10^{-6} \text{ N-m.}$

(b) $\theta = 80^\circ$

A tangent is drawn to the curve at 80° and slope is found

$$\left(\frac{dL}{d\theta} \right)_{80} = \frac{396.5 - 375}{90 - 51} = 0.55 \mu\text{H/degree} = 31.5 \mu\text{H/rad.}$$

$$\therefore 80 = \frac{1}{2} \times \frac{1}{4 \times 10^{-6}} \times I^2 \times 31.5 \times 10^{-6} \quad \text{or } I = 1.425 \text{ A}$$

Deflecting torque $T_d = 0.4 \times 10^{-6} \times 80 = 32 \times 10^{-6} \text{ N-m.}$

Example 8'22. The relationship between inductance of a moving iron ammeter, the current and the position of the pointer is as follows :

Reading (A)	1.2	1.4	1.6	1.8
Deflection (degree)	36.5	49.5	61.5	74.5
Inductance (μH)	575.2	576.5	577.8	578.8

Calculate the deflecting torque and the spring constant when the current is 1.5 A.

Solution : The relationship between deflection and current and between deflection and inductance are plotted as shown in Fig. 8'39.

Corresponding to a current of 1.5 A, the deflection is 55.5 degrees. At this deflection, the rate of change of inductance with deflection is almost linear.

From the graph of inductance v/s deflection $\frac{dL}{d\theta} = \frac{577.65 - 576.5}{60 - 49.5} = 0.1 \mu\text{H/deg.} = 5.73 \mu\text{H/rad.}$

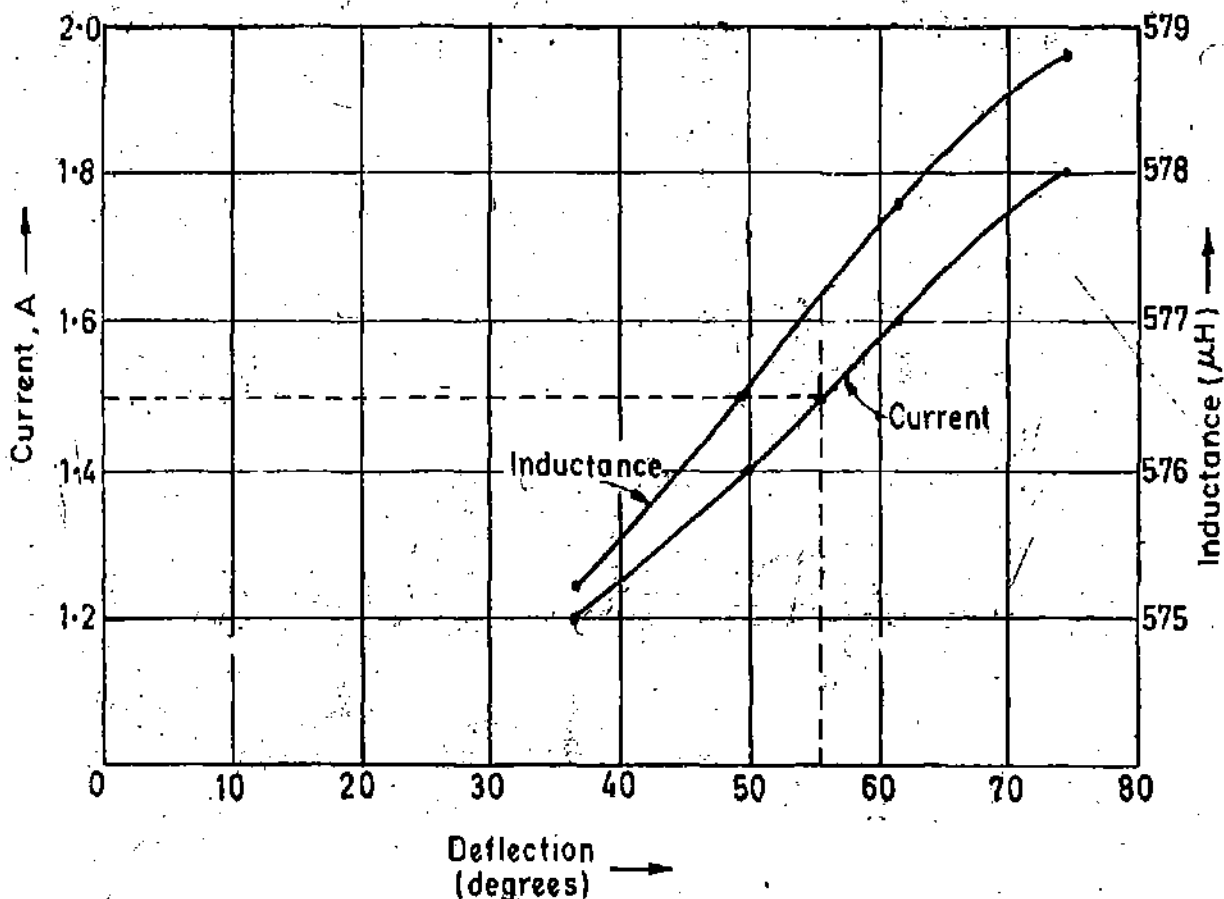

Fig. 8'39

$$\text{Deflecting torque } T_d = \frac{1}{2} I^2 \frac{dL}{d\theta} = \frac{1}{2} (1.5)^2 \times 5.73 \times 10^{-6} = 6.44 \times 10^{-6} \text{ Nm.}$$

$$\text{Deflection } \theta = 55.5 \text{ degrees} = 0.968 \text{ rad.}$$

$$\therefore \text{ Spring constant } K = \frac{T_d}{\theta} = \frac{6.44 \times 10^{-6}}{0.968} = 6.65 \times 10^{-6} \text{ Nm/rad.}$$

Example 8'23. Calculate the constants of a shunt to extend the range of 0–5 A moving iron ammeter to 0–50 A. The instrument constants are $R=0.09 \Omega$ and $L=90 \mu\text{H}$.

If the shunt is made non-inductive and the combination is correct on d.c., find the full scale error at 50 Hz.

Solution. Multiplying power of shunt $m = \frac{I}{I_m} = \frac{50}{5} = 10.$

In order that the meter may read correctly at all frequencies the time constants of meter and shunt circuits should be equal. Under this condition multiplying power m is :

$$m = 1 + \frac{R}{R_{sh}}$$

$$\therefore \text{ Resistance of shunt } R_{sh} = \frac{R}{m-1} = \frac{0.09}{10-1} = 0.01 \Omega. \text{ Also, } \frac{L}{R} = \frac{L_{sh}}{R_{sh}}$$

$$\therefore \text{ Inductance of shunt } L_{sh} = \frac{L}{R} R_{sh} = \frac{90}{0.09} \times 0.01 = 10 \mu\text{H.}$$

With d.c., the current through the meter for a total current of 50 A is :

$$I_m = \frac{R_{sh}}{R+R_{sh}} \times I = \frac{0.01}{0.09+0.01} \times 50 = 5.0 \text{ A.}$$

With 50 Hz, the current through the meter for a total current of 50 A is

$$I_m = \frac{R_m}{\sqrt{(R+R_m)^2 + \omega^2 L^2}} \times I$$

$$= \frac{0.01}{\sqrt{(0.09 \times 0.01)^2 + (2\pi \times 50 \times 90 \times 10^{-6})^2}} \times 50 = 4.81 \text{ A.}$$

Since the metre reading is proportional to the current,

Error $= \frac{4.81 - 5}{5} \times 100 = -3.8\%$ or the meter reads 3.8% low.

Example 8.24. The coil of a 300 V moving iron voltmeter has a resistance of 500 Ω and an inductance of 0.8 H. The instrument reads correctly at 50 Hz a.c. supply and takes 100 mA at full scale deflection. What is the percentage error in the instrument reading when it is connected to 200 V d.c. supply.

Solution : Resistance of coil at 50 Hz, $X = 2\pi \times 50 \times 0.8 = 251.2 \text{ } \Omega$.

Current taken by meter at 50 Hz and 300 V, $I_m = 100 \text{ mA} = 0.1 \text{ A}$.

Impedance of meter at 50 Hz, $Z = \frac{300}{0.1} = 3000 \text{ } \Omega$.

∴ Resistance of meter circuit $= \sqrt{Z^2 - X^2} = \sqrt{(3000)^2 - (251.2)^2} = 2989 \text{ } \Omega$.

Current taken by meter at 200 V, 50 Hz supply $= \frac{200}{3000} \text{ A}$.

Current taken by instrument with 200 volt d.c. $= \frac{200}{R} = \frac{200}{2989} \text{ A}$.

The deflection is proportional to the operating current. Also the instrument reads correctly with 50 Hz a.c.

Hence reading of instrument with 200 V d.c.

$$= \frac{\text{current with 200 volt d.c.} \times \text{reading with 200 volt 50 Hz a.c.}}{\text{current with 200 volt 50 Hz a.c.}} = \frac{200/2989}{200/3000} \times 200 = 200.7 \text{ V.}$$

Example 8.25. A 0–10 A moving iron ammeter is converted to a 0–500 V, 50 Hz voltmeter by adding a series resistance with the coil. The coil has negligible resistance and an inductance $L = (0.01 + 0.2\theta)/4\pi$ henry, where θ is the deflection in radian. The total angular span of the meter is 100°. Compute (a) the spring constant of the meter and (b) the series resistance required.

Solution : Now, $L = \frac{0.01 + 0.2\theta}{4\pi}$ henry ∴ $\frac{dL}{d\theta} = \frac{0.1}{2\pi} \text{ H/rad.}$

(a) Spring constant $K = \frac{1}{2\theta} I^2 \frac{dL}{d\theta} = \frac{1 \times (10)^2}{2 \times 100 \times \pi / 180} \times \frac{0.1}{2\pi} = 0.456 \text{ N-m/rad.}$

(b) Impedance required to convert the meter to 500 V voltmeter

$$Z = \frac{500}{10} = 50 \text{ } \Omega.$$

Inductance of meter coil full scale deflection $L = \frac{0.01 + 0.2\theta}{2\pi} = \frac{0.01 + 0.2 \times 100 \times \pi / 180}{4\pi} = 0.0278 \text{ H.}$

Reactance of meter coil at 50 Hz = $2\pi \times 50 \times 0.0278 = 8.73 \Omega$.

\therefore Series resistance required $R_s = \sqrt{(50)^2 - (8.73)^2} = 49.2 \Omega$.

Example 8.26. The operating coil of a 250 V moving-iron voltmeter has a resistance of 500 Ω and an inductance of 1.0 H. The series resistance is 2000 Ω . The instrument reads correctly when a direct voltage of 250 V is applied. What will it read when 250 V at 50 Hz is applied? With what value of capacitance must the series resistance be shunted to make the meter read correctly at 50 Hz?

Solution : The impedance of the voltmeter circuit at 50 Hz, $Z = \sqrt{(R + R_s)^2 + \omega^2 L^2}$
 $= \sqrt{(2,000 + 500)^2 + (2\pi \times 50 \times 1)^2} = 2520 \Omega$.

With d.c. $Z = R + R_s = 2500 \Omega$.

The error is due to change of current on account of increase in impedance on a.c.

\therefore Reading at 250 V and 50 Hz = $\frac{2500}{2520} \times 250 = 248$ V.

From Eqn. 8.58 value of capacitance

$$C = 0.41 \frac{L}{R_s^2} = 0.41 \times \frac{1}{(2000)^2} \approx 0.1 \mu\text{F}.$$

Example 8.27. The coil of a 150 V moving iron voltmeter has a resistance of 400 Ω and an inductance of 0.75 H. The coil is made of copper which has a resistance temperature co-efficient of 0.004 $^{\circ}\text{C}$. The current consumed by the instrument when placed on a 150 V d.c. supply is 0.05 A. The series resistance of the voltmeter is of Manganin with a resistance temperature co-efficient 0.00015 $^{\circ}\text{C}$. Estimate

- the temperature co-efficient of the instrument,
- the alteration of the reading between direct current and alternating current at 100 Hz,
- the capacitance of the capacitor necessary to eliminate this frequency error.

Solution : Total resistance of instrument circuit = $\frac{150}{0.05} = 3000 \Omega$

Resistance of coil $R = 400 \Omega$ \therefore Series resistance $R_s = 3000 - 400 = 2600 \Omega$.

(a) Change in resistance of coil/ $^{\circ}\text{C} = 0.004 \times 400 \times 1 = 1.60 \Omega$

Change in swamping resistance/ $^{\circ}\text{C} = 0.00015 \times 2600 \times 1 = 0.39 \Omega$

Total change in resistance of instrument circuit/ $^{\circ}\text{C} = 1.60 + 0.39 = 1.99 \Omega$

\therefore Resistance temperature co-efficient of instrument = $\frac{\text{change in resistance}/^{\circ}\text{C}}{\text{total resistance}}$

$$= \frac{1.99}{3000} = 0.00066 \Omega/\Omega.^{\circ}\text{C}.$$

(b) Reactance of coil at 100 Hz = $2\pi \times 100 \times 0.75 = 472 \Omega$.

Impedance of instrument at 100 Hz = $\sqrt{(2000)^2 + (472)^2} = 3037 \Omega$.

Current drawn by instrument at 100 Hz = $\frac{150}{3037}$ A.

\therefore Reading of instrument at 100 Hz = $\frac{150}{3037 \times 0.05} \times 150 = 148.17$ V

$$\text{Error} = \frac{148.17 - 150}{150} \times 100 = 1.2\% \text{ low.}$$

(c) In order that there is no frequency error (Eqn. 8'58)

$$C = 0.41 \frac{L}{R_s^2} = 0.41 \times \frac{0.75}{(2600)^2} \text{ F} = 0.0455 \text{ } \mu\text{F}.$$

Example 8'28. A moving iron instrument has a full scale current of 100 mA. It is converted into a 250 V voltmeter by using a series resistance made of a material having negligible resistance temperature co-efficient. The meter has a resistance of 320 Ω at 20 °C. After carrying a steady current of 100 mA for a long time, the resistance of the coil increases to 369 Ω due to self-heating. Calculate the error due to self-heating when a voltage of (a) 250 V, (b) 125 V is applied continuously.

Solution : Total resistance of the circuit when the meter is converted to a 250 V voltmeter

$$R = \frac{250}{100 \times 10^{-3}} = 2500 \text{ } \Omega$$

Resistance of the series resistor $R_s = 2500 - 320 = 2180 \text{ } \Omega$.

(a) When a voltage of 250 V is applied continuously the total circuit resistance becomes $2180 + 369 = 2549 \text{ } \Omega$

$$\therefore \text{ Voltmeter reading} = \frac{2500}{2549} \times 250 = 245.2 \text{ V.}$$

$$\text{Hence error due to self-heating} = \frac{245.2 - 250}{250} \times 100 = -1.92 \%$$

(b) When a voltage of 125 V is applied continuously the increase in temperature and consequently the change in resistance is 1/4 of the value with 250 V applied continuously,

$$\therefore \text{ Change in resistance of coil} = \frac{369 - 320}{4} = 12.25 \text{ } \Omega$$

Hence the resistance of voltmeter circuit $= 2500 + 12.25 = 2512.25 \text{ } \Omega$

$$\therefore \text{ Voltmeter reading} = \frac{2500}{2512.25} \times 125 = 124.4 \text{ V.}$$

$$\text{Hence, error} = \frac{124.4 - 125}{125} \times 100 = -0.48 \%$$

8'40. Electrodynamic (Electrodynamic) type Instruments

The necessity for the a.c. calibration of moving iron instruments as well as other types of instruments which cannot be correctly calibrated requires the use of a transfer type of instrument which is equally accurate on both a.c. and d.c. This is necessary since all measurements, and hence the calibration of all indicating instruments, must eventually be referred to standards of voltage and resistance. These standards are precision resistors and the Weston standard cell (which is a d.c. cell). It is obvious, therefore, that it would be impossible to calibrate an a.c. instrument directly against the fundamental standards.

The calibration of an a.c. instrument may be performed as follows : The transfer instrument is first calibrated on d.c. This calibration is then transferred to the a.c. instrument on alternating current, using operating conditions under which the latter operates properly.

Electrodynamic instruments are capable of service as transfer instruments. Indeed, their principal use as ammeters and voltmeters in laboratory and measurement work is for the transfer calibration of working instruments.

Electrodynamometer type of instruments are used as a.c. voltmeters and ammeters both in the range of power frequencies and lower part of the audio frequency range. They are used as wattmeters, varmeters and with some modification as power factor meters and frequency meters.

8'41. Operating Principle. We can have an idea of the working principle of this instrument by taking up a permanent magnet moving coil instrument and considering how it would behave on a.c. It would have a torque in one direction during one half of the cycle and an equal effect in the opposite direction during the other half of the cycle. If the frequency were very low, the pointer would swing back and forth around the zero point. However, for an ordinary meter, the inertia is so great that on power frequencies the pointer does not go very far in either direction but merely stays (vibrates slightly) around zero. If, however, we were to reverse the direction of the field flux each time the current through the movable coil reverses, the torque would be produced in the same direction for both halves of the cycle. The field can be made to reverse simultaneously with the current in the movable coil if the field coil is connected in series with the movable coil.

8'42. Construction. Fixed Coils : The field is produced by a fixed coil. This coil is divided into two sections to give a more uniform field near the centre and to allow passage of the instrument shaft. The instrument as shown in Fig. 8'40 may be a milliammeter, or may become a voltmeter by the addition of a series resistance. The fixed coils are wound with fine wire for such applications.

Field (fixed) coils are usually wound with heavy wire carrying the main current in ammeters and wattmeters. The wire is stranded where necessary to reduce eddy current losses in conductors. The coils are usually varnished and baked to form a solid assembly. These are then clamped in place against the coil supports. This makes the construction rigid so that there is no shifting or change in dimensions which might effect the calibration.

The mounting supports are preferably made out of ceramic, as metal parts would weaken the field of the fixed coil on account of eddy currents.

Moving Coil. A single element instrument has one moving coil. The moving coil is wound either as a self-sustaining coil or else on a non-metallic former. A metallic former cannot be used as eddy currents would be induced in it by the alternating field. Light but rigid construction is used for the moving coil. It should be noted that both fixed and moving coils are air cored.

Control. The controlling torque is provided by two control springs. These springs act as leads to the moving coil.

Moving System. The moving coil is mounted on an aluminium spindle. The moving system also carries the counter weights and truss type pointer. Sometimes a suspension may be used in case high sensitivity is desired.

Damping. Air friction damping is employed for these instruments and is provided by a pair of aluminium vanes, attached to the spindle at the bottom. These vanes move in sector shaped chambers.

Shielding : The field produced by the fixed coils is somewhat weaker than in other types of instruments. It is nearly 0.005 to 0.006 Wb/m^2 . In d.c. measurements even the earth's magnetic field may affect the readings. Thus it is necessary to shield an electro-dynamometer type instrument from the effect of stray magnetic fields. Air cored electro-dynamometer type instruments are protected against external magnetic fields by enclosing them in a casing of high permeability alloy. This shunts external magnetic fields around the instrument mechanism and minimize their effects on the indication. Double casing is highly effective in the case of precision instruments. The outer casing is made up of a material of high saturation density and low coercive force, while the inner casing is made up of a material having high initial permeability.

Cases and Scales. Laboratory standard instruments are usually contained in highly polished

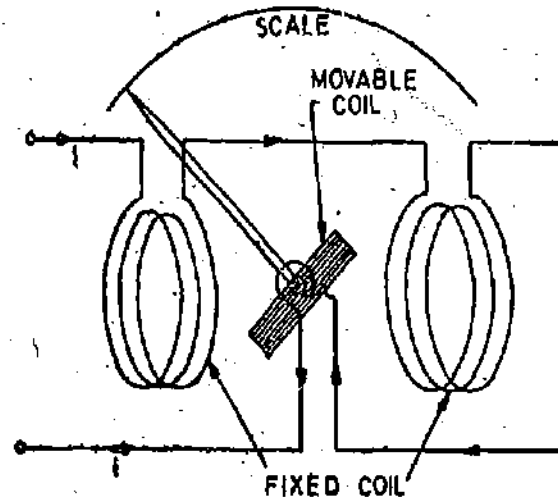

8'40. Dynamometer type instrument.

wooden cases. These cases are so constructed as to remain dimensionally stable over long periods of time. The glass is coated with some conducting material to completely remove the electrostatic effects. The case is supported by adjustable levelling screws. A spirit level is also provided to ensure proper levelling.

The scales are hand drawn, using machine sub-dividing equipment. Diagonal lines for fine sub-division are usually drawn for main markings on the scale. Most of the high-precision instruments have a 300 mm scale with 100, 120 or 150 divisions.

8'43. Torque Equation

- Let i_1 = instantaneous value of current in the fixed coils ; A,
- i_2 = instantaneous value of current in the moving coil ; A,
- L_1 = self-inductance of fixed coils ; H,
- L_2 = self-inductance of moving coils ; H,
- M = mutual inductance between fixed and moving coils ; H.

Referring to Fig.8'41.

Flux linkages of coil 1, $\lambda_1 = L_1 i_1 + M i_2$

Flux linkages of coil 2, $\lambda_2 = L_2 i_2 + M i_1$

Electrical input energy

$$= e_1 i_1 dt + e_2 i_2 dt = i_1 d\lambda_1 + i_2 d\lambda_2$$

$$\text{as } e_1 = \frac{d\lambda_1}{dt} \text{ and } e_2 = \frac{d\lambda_2}{dt}$$

$$= i_1 d(L_1 i_1 + M i_2) + i_2 d(L_2 i_2 + M i_1)$$

$$= i_1 L_1 di_1 + i_1^2 dL_1 + i_1 i_2 dM + i_1 M di_2 + i_2 L_2 di_2 + i_2^2 dL_2 + i_1 i_2 dM + i_2 M di_1 \quad \dots(i)$$

Energy stored in the magnetic field = $\frac{1}{2} i_1^2 L_1 + \frac{1}{2} i_2^2 L_2 + i_1 i_2 M$

Change in energy stored = $d(\frac{1}{2} i_1^2 L_1 + \frac{1}{2} i_2^2 L_2 + i_1 i_2 M)$

$$= i_1 L_1 di_1 + (i_1^2/2) dL_1 + i_2 L_2 di_2 + (i_2^2/2) dL_2 + i_1 M di_2 + i_2 M di_1 + i_1 i_2 dM \quad \dots(ii)$$

From principle of conservation of energy,

Total electrical input energy = change in energy stored + mechanical energy.

The mechanical energy can be obtained by subtracting (ii) from (i)

$$\therefore \text{Mechanical energy} = i_1 i_2 dM.$$

Now the self-inductances L_1 and L_2 are constant and therefore dL_1 and dL_2 are both equal to zero.

$$\text{Hence, mechanical energy} = i_1 i_2 dM.$$

Suppose T_θ is the instantaneous deflecting torque and $d\theta$ is the change in deflection, then

$$\text{work done} = T_\theta d\theta$$

Thus we have :

$$T_\theta d\theta = i_1 i_2 dM \text{ or } T_\theta = i_1 i_2 \frac{dM}{d\theta} \quad \dots(8'59)$$

Operation with D.C. Let I_1 = current in fixed coils ; A, I_2 = current in moving coil ; A.

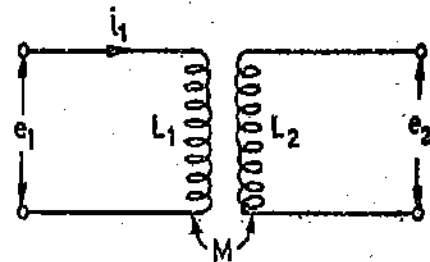

Fig. 8'41

$$\therefore \text{From Eqn. 8'59 deflecting torque } T_d = I_1 I_2 \frac{dM}{d\theta} \quad \dots(8'60)$$

Eqn. 8'60 shows that the deflecting torque depends in general on the product of currents I_1 and I_2 and the rate of change of mutual inductance.

This deflecting torque deflects the moving coil to such a position where the controlling torque of the spring is equal to the deflecting torque. Suppose θ = final steady deflection

$$\therefore \text{Controlling torque } T_c = K\theta.$$

At final steady position $T_d = T_c$

$$I_1 I_2 \frac{dM}{d\theta} = K\theta \quad \text{or deflection } \theta = \frac{I_1 I_2}{K} \cdot \frac{dM}{d\theta} \quad \dots(8'61)$$

Operation with A.C. Let i_1 and i_2 be the instantaneous values of currents carried by the coils. Therefore, the instantaneous deflecting torque is :

$$T_i = i_1 i_2 \frac{dM}{d\theta} \quad (\text{See Eqn. 8'59})$$

The average deflection torque over a complete cycle

$$T_a = \frac{1}{T} \int_0^T T_i dt$$

$$= \frac{dM}{d\theta} \frac{1}{T} \int_0^T i_1 i_2 dt \quad \dots(8'62)$$

where T = time period for one complete cycle.

Sinusoidal Currents. If currents i_1 and i_2 are sinusoidal and are displaced by a phase angle ϕ , i.e.,

$$i_1 = I_{m1} \sin \omega t \quad \text{and} \quad i_2 = I_{m2} \sin (\omega t - \phi)$$

\therefore The average deflecting torque

$$T_a = \frac{dM}{d\theta} \frac{1}{T} \int_0^T i_1 i_2 dt = \frac{dM}{d\theta} \frac{1}{T} \int_0^T I_{m1} \sin \omega t \cdot I_{m2} \sin (\omega t - \phi) dt$$

$$= \frac{dM}{d\theta} I_{m1} I_{m2} \cdot \frac{1}{2\pi} \int_0^{2\pi} \sin \omega t \sin (\omega t - \phi) d(\omega t) = \frac{I_{m1} I_{m2}}{2} \cos \phi \cdot \frac{dM}{d\theta} = I_1 I_2 \cos \phi \frac{dM}{d\theta}$$

$\dots(8'63)$

where I_1 and I_2 are rms values of current flowing in the coils,

At equilibrium $T_d = T_c$

or $I_1 I_2 \cos \phi \cdot \frac{dM}{d\theta} = K\theta$.

\therefore Deflection $\theta = \frac{I_1 I_2}{K} \cos \phi \cdot \frac{dM}{d\theta}$... (8'64)

It follows from the above that for sinusoidal alternating currents the deflecting torque and the deflection are determined by the product of the rms values of the coil currents and cosine of the phase angle between them.

8'44. Electro-dynamometer Ammeters. Fig. 8'43 shows that the arrangement of coils of an electro-dynamometer ammeter.

In this case the fixed and moving coils are connected in series and, therefore, carry the same current i.e. $I_1 = I_2 = I$ and $\phi = 0$.

\therefore Deflecting torque $T_d = I^2 \frac{dM}{d\theta}$ (See Eqn. 8'63) ... (8'65)

and deflection $\theta = \frac{I^2}{K} \frac{dM}{d\theta}$... (8'66)

Due to some considerations explained later, the current through the moving coil should not exceed 200 mA and, therefore, the arrangement of Fig. 8'40 is suitable for ammeters having a range upto 200 mA.

For ammeters of higher capacity, the arrangement shown in Fig. 8'42 is used. In this case the moving coil is connected in series with its swamping resistance across a shunt together with fixed coils. Thus there are two separate parallel branches for fixed and moving coils. In order that the ammeter may indicate correctly at all frequencies, the currents in the fixed and moving coils must be in phase. This requires the time constant L/R of two branches to be equal as otherwise the currents in the two branches will not be independent of frequency. Using this arrangement we can easily make L/R ratio equal for both branches.

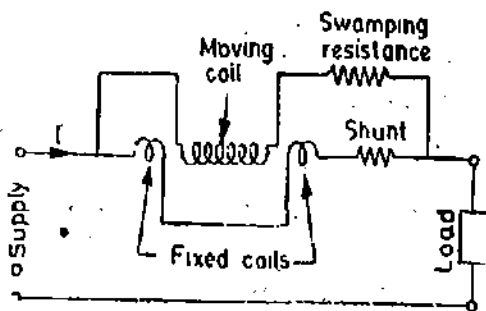

Fig. 8'42. Electro-dynamometer Ammeter. (Above 200 mA)

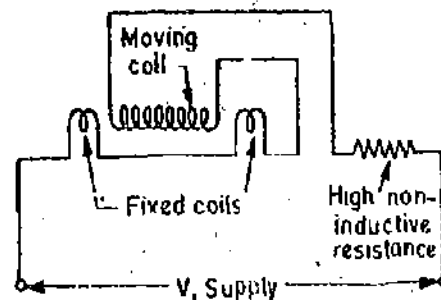

Fig. 8'43. Electro-dynamometer Voltmeter.

8'45. Electro-dynamometer Voltmeters. The electro-dynamometer movement is used as a voltmeter by connecting the fixed and moving coils in series with a high non-inductive resistance. The arrangement is shown in Fig. 8'43.

Deflecting torque $T_d = I_1 I_2 \cos \phi \frac{dM}{d\theta}$

In this case $I_1 = I_2 = \frac{V}{Z}$ and $\phi = 0 \therefore T_d = \frac{V}{Z} \cdot \frac{V}{Z} \frac{dM}{d\theta}$
 $= \frac{V^2}{Z^2} \frac{dM}{d\theta}$... (8'67)

where V = voltage across the instrument, Z = impedance of the instrument circuit.

$$\text{Deflection} \quad \theta = \frac{V^2}{KZ^2} \cdot \frac{dM}{d\theta} \quad \dots(8'68)$$

Electrodynamometer type voltmeter is the most accurate type of a.c. voltmeter. But the sensitivities are low in comparison with the d.c. instruments, and range from 10 to 30 Ω/V .

8'46. Errors. The main sources of error in a dynamometer type of instruments are due to (i) low torque/weight ratio, (ii) frequency, (iii) eddy currents, (iv) external magnetic fields, (v) temperature change.

(i) Torque/Weight ratio. The magnetic field produced by air cored coils is essentially small and, therefore, flux linkages per ampere in the moving coil are few (perhaps 3 to 4 percent of flux linkages per ampere in the permanent magnet moving coil instruments). Therefore, the deflecting torque is low. Thus to produce a reasonable deflecting torque, the mmf of the moving coil must be increased. The mmf of the moving coil can be increased by increasing the current through the coil or by increasing the number of turns. The current through the moving coil cannot be increased beyond 200 mA as otherwise the springs would be heated too much. On the other hand an increase in the number of turns of the moving coil, will give rise to increased weight of moving parts resulting in a low torque/weight ratio. A low torque/weight ratio indicates a heavy moving system and, therefore, the friction losses in electro-dynamometer type of instrument are larger than in other types. Frictional errors tend to be high.

(ii) Frequency. The frequency error of dynamometer type instrument is due largely as a result of variation of self-reactance of coils, with frequency. In case of voltmeters,

$$\text{Deflection} \quad \theta = \frac{V^2}{RZ^2} \cdot \frac{dM}{d\theta} \quad \text{Now} \quad Z = \sqrt{R^2 + (2\pi fL)^2}$$

and, therefore, the value of impedance Z increases with frequency and hence the voltmeters tend to read low as the frequency is increased. Therefore, in order to reduce frequency errors in voltmeters the coil winding is made a very small part of the circuit. This makes the inductive reactance, a small fraction of total impedance and, therefore,

$$Z = \sqrt{R^2 + (2\pi fL)^2} \approx R$$

This means that the frequency does not effect the calibration of the instrument. In fact, electro-dynamometer voltmeters may be used, in general, within their guaranteed accuracy from d.c. to about 125 Hz.

In order to reduce frequency error in dynamometer ammeters (Fig. 8'42) the ratio of currents in fixed and moving coils i.e., I_1/I_2 should be independent of frequency. This requires the time constants of two circuits should be the same.

Let R_1, L_1, Z_1 = resistance, inductance and impedance of fixed coil circuit

R_2, L_2, Z_2 = resistance, inductance and impedance of moving coil circuit.

$$\text{We have} \quad \frac{I_2}{I_1} = \frac{Z_1}{Z_2} = \frac{\sqrt{R_1^2 + (2\pi fL_1)^2}}{\sqrt{R_2^2 + (2\pi fL_2)^2}} = \frac{R_1 \sqrt{1 + (2\pi f)^2(L_1/R_1)^2}}{R_2 \sqrt{1 + (2\pi f)^2(L_2/R_2)^2}}$$

$$\text{Now if } \frac{L_1}{R_1} = \frac{L_2}{R_2}, \text{ ratio of currents with a.c. is } \frac{I_2}{I_1} = \frac{R_1}{R_2}$$

$$\text{Ratio of currents with d.c. is } \frac{I_2}{I_1} = \frac{R_1}{R_2}$$

Thus the ratio of currents with a.c. is the same as with d.c. if the time constants (ratio L/R) of fixed and moving coil circuits are the same. Therefore, the frequency error in shunted ammeters can be eliminated by having equal time constants for both fixed and moving coil circuits.

Also the phase difference between the two currents is zero.

(iii) **Eddy Currents.** The effect of eddy currents is to produce a torque as a result of coupling between moving coil and the adjacent metal parts. Hence, metal in the coil supports and structural part is kept to the minimum possible. Any metal that is used is kept away and is selected to have high resistivity so as to reduce eddy currents induced in it. The metal present in coil supports, in the shield etc., produces a frequency error in the instrument as already seen in the case of moving iron instruments.

(iv) **External Magnetic Fields.** Since the operating field in electro-dynamometer instruments is weak, therefore, these must be protected from the external magnetic fields. Portable Instruments use metal shields which serve to isolate the coils from external influences.

Precision type of instruments are unshielded as eddy currents are induced in the metal shields which introduce errors. In precision instruments the influence of external magnetic fields can be minimized by using "Astatic System". Astatic electro-dynamometer instruments are constructed with two similar sets of fixed and moving coils mounted on the same shaft (Fig. 8'44). The two pairs of fixed coils are so connected that their magnetic fields are in opposition. The currents in the moving coils are also opposed and, in consequence, the deflecting torques applied to the moving coils act in the same direction. Since the two fields are in opposition and, therefore, any uniform external field reduces the field of one coil and increases by an equal amount, the field of the other coil. Therefore the deflecting torque produced by one coil is increased while that produced by the other coil is reduced by an equal amount and, thus, the net torque on account of of the external magnetic field is zero.

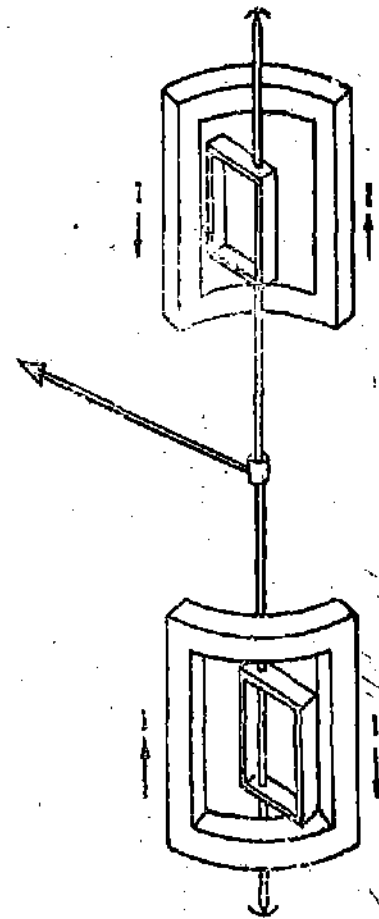

Fig 8'44. Astatic System.

(v) **Temperature Changes.** High currents are carried by coils which produce heat. Self-heating of coils produces errors.

High accuracy instruments contain temperature compensating resistors which tend to neutralize the effects of temperature changes.

8'47. **Use on D.C. and A.C.** The electro-dynamometer type of instrument can be used on both d.c. and a.c. When being used on a.c. the instantaneous torque is proportional to i^2 (for an ammeter). As the current varies the torque also varies but always remains in the same direction. The pointer is not able to follow the individual torque pulsations but takes up a position where the average torque is equal to the controlling torque. Thus the instrument can be used on both a.c. and d.c. The instrument if initially calibrated on d.c., the calibration holds true for a.c. as well in which case the instrument reads the rms value of the current.

8'48. **Shape of Scale.** We have deflection $\theta \propto I^2 \frac{dM}{d\theta}$ for an ammeter and $\theta \propto V^2 \frac{dM}{d\theta}$ for a voltmeter.

Thus it is clear from above that the scale of a dynamometer type of ammeter or a voltmeter is not uniform. The instruments have a "square law" response.

We have assumed the value of $(\frac{dM}{d\theta})$ to be constant but it is not true. The value of $(\frac{dM}{d\theta})$ is constant for a radial field but for a parallel field, which is obtained in a dynamometer type instrument, it is not constant.

Fig. 8'45 shows a dynamometer type of instrument in which a parallel field is produced by the fixed coils. The mutual inductance, M , between fixed coils and moving coil depends upon the position of the moving coil. The maximum value of the mutual inductance M_{max} occurs when $\theta = 180^\circ$, as this position gives the maximum flux

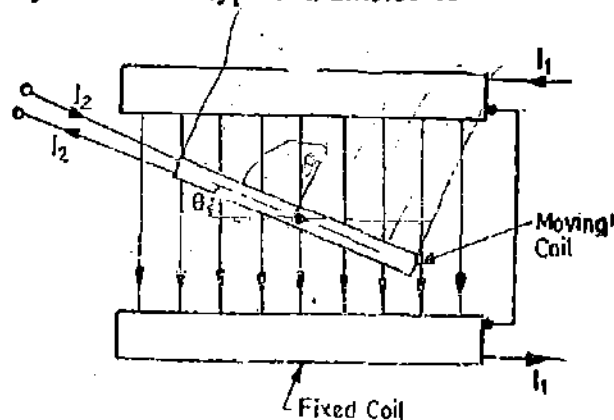

Fig. 8'45. Variation of mutual inductance with coil position.

linkages. When $\theta=0$, $M=-M_{max}$. If the flux density of the magnetic field, in which the moving coil moves, is uniform the flux linkages and hence the mutual inductance is proportional to the projected area of the coil on a plane perpendicular to the axis of the fixed coils.

Hence the mutual inductance M at any angle θ is : $M = -M_{max} \times \cos \theta$... (8'69)

or $\frac{dM}{d\theta} = M_{max} \times \sin \theta$... (8'70)

Thus the deflecting torque of a dynamometer type of instrument is given by

$$T_d = I_1 I_2 M_{max} \cos \phi \sin \theta \quad \dots (8'71)$$

and $\theta = \frac{I_1 I_2}{K} M_{max} \cos \phi \sin \theta$... (8'72)

It is clear from Eqn. 8'72 the instrument does not have a pure "square law" response.

In electro-dynamometer instruments, as usually constructed, θ varies from about 45° to 135° , i.e. from -45° to 45° from the position of zero mutual inductance and as changes in value of θ over this range are not large i.e. $(dM/d\theta)$ is practically constant over this range, the instrument shows almost a square law response.

Also in practice, the field due to fixed coils is not uniform, and by careful design of the coil, $(dM/d\theta)$ may be made constant over the range 45° to 135° and hence the instrument may show a true square law response.

8'49. Advantages and Disadvantages

Advantages. (i) As the coils are air cored, these instruments are free from hysteresis and eddy current errors.

(ii) They have a precision grade accuracy for frequencies upto 40 to 500 Hz, the lower range being decided by the oscillations of the pointer. Lower grade instruments can be used for a frequency range of 15 to 1000 Hz. Unshielded instruments using astatic movement can be used for frequencies upto 10 kHz.

(iii) These instruments can be used on both a.c. and d.c. and since they have a precision grade accuracy, they are very useful as transfer instruments.

(iv) Electro-dynamometer voltmeters are very useful where accurate rms values of voltage, irrespective of waveforms, are required. This is shown below.

Let the voltage applied to the voltmeter be represented as :

$$e = E_{m1} \sin(\omega t + \alpha_1) + E_{m2} \sin(2\omega t + \alpha_2) + \dots + E_{mn} \sin(n\omega t + \alpha_n) + \dots$$

The instantaneous torque in an electro-dynamometer instrument is proportional to square of voltage. Therefore, we can write :

$$T_i \propto [E_{m1} \sin(\omega t + \alpha_1) + E_{m2} \sin(2\omega t + \alpha_2) + \dots + E_{mn} \sin(n\omega t + \alpha_n) + \dots]^2$$

$$\text{The average deflecting torque } T_d \propto \frac{1}{T} \int_0^T T_i dt$$

$$\propto \frac{1}{T} \int_0^T [E_{m1} \sin(\omega t + \alpha_1) + E_{m2} \sin(2\omega t + \alpha_2) + \dots + E_{mn} \sin(n\omega t + \alpha_n) + \dots]^2 dt$$

$$\propto \frac{1}{2\pi} \int_0^{2\pi} [E_{m1} \sin(\alpha + \alpha_1) + E_{m2} \sin(2\alpha + \alpha_2) + \dots + E_{mn} \sin(n\alpha + \alpha_n) + \dots]^2 d\alpha$$

$$\text{Now, we have } \frac{1}{2\pi} \int_0^{2\pi} E_{mp}^2 \sin^2 (p\alpha + \alpha_p) d\alpha = \frac{E_{mp}^2}{2}$$

$$\text{and } \frac{1}{2\pi} \int_0^{2\pi} [E_{mp} \sin (p\alpha + \alpha_p) \times E_{mq} \sin (q\alpha + \alpha_q)] d\alpha = 0$$

The average deflecting torque

$$T_d \propto \frac{1}{2} [E_{m1}^2 + E_{m2}^2 + E_{m3}^2 \dots + E_{mn}^2 + \dots] \propto [E_1^2 + E_2^2 + \dots + E_n^2 + \dots]$$

$$\text{where } E_1 = \frac{E_{m1}}{\sqrt{2}}, E_2 = \frac{E_{m2}}{\sqrt{2}} \dots, E = \frac{E_{mn}}{\sqrt{2}} \quad \text{But } [E_1^2 + E_2^2 + \dots + E_n^2 + \dots] = E^2$$

where E is the r.m.s. value of voltage. $\therefore T_d \propto E^2$

Hence the deflecting torque in an electro-dynamometer type of voltmeter is proportional to square of the rms value of applied voltage.

This is also true of an ammeter where the two circuits have the same time constant.

Disadvantages. (i) It has a low torque/weight ratio and hence has a low sensitivity.

(ii) Low torque/weight ratio gives increased frictional losses. These errors must be minimized if high accuracy is desired. This is attained by a reasonable reduction in weight of moving element, proper selection of materials for spindle and bearings and adequately polishing these parts. These measures make the instrument more costly and are not, therefore, useful for general industrial use.

(iii) It is more expensive than either the PMMC or the moving iron type instrument.

(iv) These instruments are sensitive to overloads and mechanical impacts. Therefore, they must be handled with great care.

(v) The operating current of these instruments is large owing to the fact that they have weak magnetic field. The power consumption of meters is high as compared with PMMC type instruments.

(vi) They have a non-uniform scale.

(vii) Their general frequency range is from 0 onwards but moving system tends to follow the pulsations in torque at low frequencies. Thus measurements at frequencies as low as 5 Hz to 15 Hz become impractical. Measurements at these low frequencies require special structures with abnormal damping.

8'50. Ranges

Ammeters. (i) Fixed and moving coils in series—upto 200 mA.

(ii) Moving coil shunted —upto 30 A.

Voltmeters. Upto 750 V.

8'51. Use of Electro-dynamometer Type Instruments at High Frequencies. The normal designs of electro-dynamometer instruments can be used for frequencies upto 125 Hz. Thus certain modifications are necessary to extend the frequency range of these instruments. The modifications vary with the use of the instrument *i.e.*, whether the instrument is to be used as voltmeter or ammeter and thus these modifications are considered under separate headings.

Ammeters. At the lower audio frequencies, eddy currents in metal parts reduce the operating flux and thus reduce the torque for a given current. At higher audio frequencies, self-capacitance of the coils and capacitance between the coils become important. These capacitances may be considered as a shunt across the coil system, and the stray capacitance current will be nearly in anti-phase to the coil current. Thus, for a given total current, the coil current will be increased and the instrument

torque will also be increased. Such an instrument will tend to have a negative error at low audio frequencies and a positive error at high audio frequencies. Compensation for this is difficult, but an accurate electrodynamic ammeter suitable for the range 0–10 kHz may be made by ensuring that the eddy-current error is made small (e.g., by the use of the stranded conductors and laminated metal supports) and compensating for the capacitance error by an additional circuit consisting of resistance and capacitance in series, connected across the instrument terminals.

Voltmeters. Up to about 1 kHz the frequency error of an electrodynamic voltmeter is small, but at higher audio frequencies the increase in effective resistance of the coil and increase in its reactance result in a decrease in the current taken for a given applied voltage, and the instrument will have large negative error. The range for useful accuracy may be extended to the region of 5 kHz by using a capacitor in parallel with the series resistor. The theory of this compensation is given in the chapter.

Example 8'29. The inductance of a 25 A electrodynamic ammeter changes uniformly at the rate of $0.0035 \mu\text{H}/\text{degree}$. The spring constant is $10^{-6} \text{ N-m}/\text{degree}$. Determine the angular deflection at full scale.

Solution : Final steady deflection $\theta = \frac{I^2}{K} \frac{dM}{d\theta}$ (See Eqn. 8'66)

Spring constant K is expressed in $\text{N-m}/\text{degree}$ and therefore, we must express $(dM/d\theta)$ in H/rad if deflection is to be found in degrees.

$$\frac{dM}{d\theta} = \frac{0.0035}{\pi/180} \times 10^{-6} = 0.2 \times 10^{-6} \text{ Nm/rad} \quad \therefore \text{Deflection } \theta = \frac{(25)^2}{10^{-6}} \times 0.2 \times 10^{-6} = 125^\circ.$$

Example 8'30. A 10 A electrodynamic ammeter is controlled by a spring having a constant of $0.1 \times 10^{-6} \text{ N-m}/\text{degree}$. The full scale deflection is 110° . Determine the inductance of the instrument when measuring a current of 10 A. Initial inductance is $2 \mu\text{H}$ and the change is linear.

Solution : The rate of change of inductance is

$$\frac{dM}{d\theta} = \frac{K\theta}{I^2} = \frac{0.1 \times 10^{-6} \times 110}{(10)^2} = 0.11 \times 10^{-6} \text{ H/rad} = 0.00192 \mu\text{H}/\text{degree}.$$

Final inductance = initial inductance + change in inductance = $2.0 + 0.00192 \times 110 = 2.21 \mu\text{H}$.

Example 8'31. In a particular instrument the total resistance of the voltage coil circuit is 8200Ω and the mutual inductance changes uniformly from $-173 \mu\text{H}$ at zero deflection to $+175 \mu\text{H}$ at full scale, the angle of full scale being 95° . If a potential difference of 100 V is applied across the voltage circuit, and a current of 3 A at a power factor of 0.75 is passed through the current coil, what will be the deflection, if the spring control constant is $4.63 \times 10^{-6} \text{ N-m}/\text{rad}$?

Solution : Change in mutual inductance = $+175 - (-173) = 348 \mu\text{H}$.

Deflection $\theta = 95^\circ = 1.66 \text{ rad}$.

$$\text{Rate of change of mutual inductance } \frac{dM}{d\theta} = \frac{348}{1.66} = 210 \mu\text{H}/\text{rad}.$$

This problem relates to a dynamometer type instrument where the two coils carry different values of current and also there is a phase difference between them.

Current through fixed coil $I_1 = 3 \text{ A}$

$$\text{Current through moving coil } I_2 = \frac{100}{8200} = 12.2 \times 10^{-3} \text{ A} \quad \text{and } \cos \phi = 0.75.$$

Spring constant $K = 4.63 \times 10^{-6} \text{ N-m}/\text{rad} = 0.08 \times 10^{-6} \text{ N-m}/\text{degree}.$

$$\text{From Eqn. 8'64 deflection } \theta = \frac{I_1 I_2}{K} \cos \phi \frac{dM}{d\theta} = \frac{3 \times 12.2 \times 10^{-3}}{0.08 \times 10^{-6}} \times 0.75 \times 210 \times 10^{-6} = 71.5^\circ.$$

Example 8'32. For a certain dynamometer ammeter the mutual inductance M varies with deflection θ (expressed in degrees) as $M = -6 \cos(\theta + 30^\circ)$ mH.

Find the deflecting torque produced by a direct current of 50 mA corresponding to a deflection of 60° .

Solution : Rate of change of mutual conductance with deflection

$$\frac{dM}{d\theta} = \frac{d}{d\theta} [-6 \cos(\theta + 30^\circ)] = 6 \sin(\theta + 30^\circ) \text{ mH}$$

$$\frac{dM}{d\theta} \text{ at a deflection of } 60^\circ \text{ is : } \left(\frac{dM}{d\theta} \right)_{\theta=60^\circ} = 6 \sin(60^\circ + 30^\circ) \text{ mH} = 6 \times 10^{-3} \text{ H.}$$

$$\text{Deflecting torque } T_d = I^2 \frac{dM}{d\theta} = (50 \times 10^{-3})^2 \times 6 \times 10^{-3} = 15 \times 10^{-6} \text{ Nm} = 15 \mu\text{Nm.}$$

Example 8'33. A dynamometer ammeter is fitted with two fixed coils having a total resistance of 3.0Ω and a total inductance of 0.12 H , and a moving coil of resistance 30Ω and an inductance of 0.003 H . Calculate the error in reading when the instrument is calibrated with d.c. and used on a.c. 50 Hz with moving coil shunted directly across the field coils.

Solution : Resistance of fixed (field) coils $R_1 = 3.0 \Omega$.

Resistance of fixed coils at 50 Hz $X_1 = 2\pi \times 50 \times 0.12 = 37.7 \Omega$.

Resistance of moving coil $R_2 = 30 \Omega$.

Reactance of moving coil at 50 Hz $X_2 = 2\pi \times 50 \times 0.003 = 0.9425 \Omega$.

Let the current being measured be I .

$$\text{With D.C. Current through fixed coils } I_1 = \frac{R_2}{R_1 + R_2} I = \frac{30}{3 + 30} I = \frac{10}{11} I.$$

$$\text{Current through moving coils } I_2 = \frac{R_1}{R_1 + R_2} I = \frac{1}{11} I$$

$$\text{Deflection } \theta \propto I_1 I_2 = K_1 I_1 I_2 = K_1 \times \frac{10}{11} I \times \frac{1}{11} I = 0.0827 K_1 I^2$$

$$\text{With A.C. Impedance of fixed coils } Z_1 = \sqrt{(3)^2 + (37.7)^2} = 37.8 \Omega.$$

$$\text{Phase angle } \phi_1 = \tan^{-1} \frac{37.7}{3} = 85^\circ 30'$$

$$\text{Impedance of moving coil } Z_2 = \sqrt{(30)^2 + (0.9425)^2} = 30 \Omega.$$

$$\text{Phase angle } \phi_2 = \tan^{-1} \frac{0.9425}{30} = 1^\circ 48'.$$

$$\begin{aligned} \text{Current through fixed coil } I_1 &= I \frac{Z_2 \angle \alpha_1}{Z_1 \angle \alpha_1 + Z_2 \angle \alpha_2} \\ &= I \frac{30 \angle 1^\circ 48'}{\sqrt{(3 + 30)^2 + (37.7 + 0.94)^2} \left| \tan^{-1} \frac{37.7 + 0.94}{3 + 30} \right|} \\ &= I \frac{30 \angle 1^\circ 48'}{50.8 \angle 49^\circ 30'} = 0.588 I \angle -47^\circ 42' \end{aligned}$$

$$\text{Current through moving coil } I_2 = I \frac{37.8 \angle 85^\circ 30'}{50.8 \angle 49^\circ 30'} = 0.743 I \angle 36^\circ$$

Phase difference between I_1 and I_2 . $\phi = -47^\circ 42' - 36^\circ = 83^\circ 42'$, $\therefore \cos \phi = 0.1097$

Deflection with a.c. $\theta = K_1 I_1 I_2 \cos \phi = K_1 \times 0.588 \times I \times 0.743 \times I \times 0.1097 = 0.048 K_1 I^2$

Percentage error = $\frac{\text{reading on a.c.} - \text{reading on d.c.}}{\text{reading on d.c.}} \times 100$

$$= \frac{0.048 K_1 I^2 - 0.0827 K_1 I^2}{0.0827 K_1 I^2} \times 100 = -41.9\%$$

Example 8.34. A 50-volt range spring controlled electrodynamic voltmeter having a square law scale takes 0.05 A on d.c. for full scale deflection of 90° . The control constant is 0.5×10^{-6} N-m/degree and the initial inductance of the instrument is 0.25 H. Find the true potential difference across the instrument when it reads 50 V at 50 Hz.

Solution : The expression for deflection for a square law response voltmeter is :

$$\theta = \frac{V^2}{KZ^2} \frac{dM}{d\theta} \quad (\text{See Eqn. 8.68})$$

For d.c., impedance $Z = \text{resistance } R$ and, therefore, $\theta = \frac{V^2}{KR^2} \frac{dM}{d\theta}$

But $\frac{V}{R} = 0.05$ A, $K = 0.5 \times 10^{-6}$ and $\theta = 90^\circ$.

Thus we have, $90 = \frac{(0.05)^2}{0.5 \times 10^{-6}} \frac{dM}{d\theta}$ or $\frac{dM}{d\theta} = \frac{90 \times 0.5 \times 10^{-6}}{(0.05)^2} = 18 \times 10^{-3}$ H/rad.

Angle of deflection = $90^\circ = \pi/2$ rad.

Total change in mutual inductance = $18 \times 10^{-3} \times \pi/2 = 28.3 \times 10^{-3}$ H.

\therefore Inductance at $\theta = 90^\circ$ is
= initial inductance + change in inductance = $0.25 + 28.3 \times 10^{-3} = 0.2783$ H.

Reactance of instrument at 50 Hz = $2\pi \times 50 \times 0.2783 = 88.3 \Omega$.

Resistance of instrument = $\frac{50}{0.05} = 1000 \Omega$.

Impedance of instrument at 50 Hz = $\sqrt{(1000)^2 + (88.3)^2} = 1000.5 \Omega$.

Current through the instrument when reading 50 V is 0.05 A.

\therefore Actual voltage across the instrument = $0.05 \times 1000.5 = 50.025$ V.

$$T_d = I_1 I_2 \cos \phi \frac{dM}{d\theta} \quad \text{and the deflection } \theta = \frac{I_1 I_2}{K} \cos \phi \frac{dM}{d\theta}$$

Example 8.35 A dynamometer ammeter is arranged so that 1 percent of total current passes through the moving coil and rest through the fixed coil. The mutual inductance between two coils varies with the angle of displacement of the moving coil from its zero position as follows.

Angle (degrees)	0	15	30	60	90	105	120
Mutual Inductance μH	-336	-275	-192	0	192	275	336

If a torque of 10.5×10^{-6} Nm is required to give a full scale deflection of 120° . Calculate the current at half and full scale deflection.

Solution : The mutual inductance M is plotted against deflection θ as shown in Fig. 8.46.

Half full scale deflection = $120/2 = 60^\circ$.

It is clear from the data given that the M varies linearly with θ about 60° .

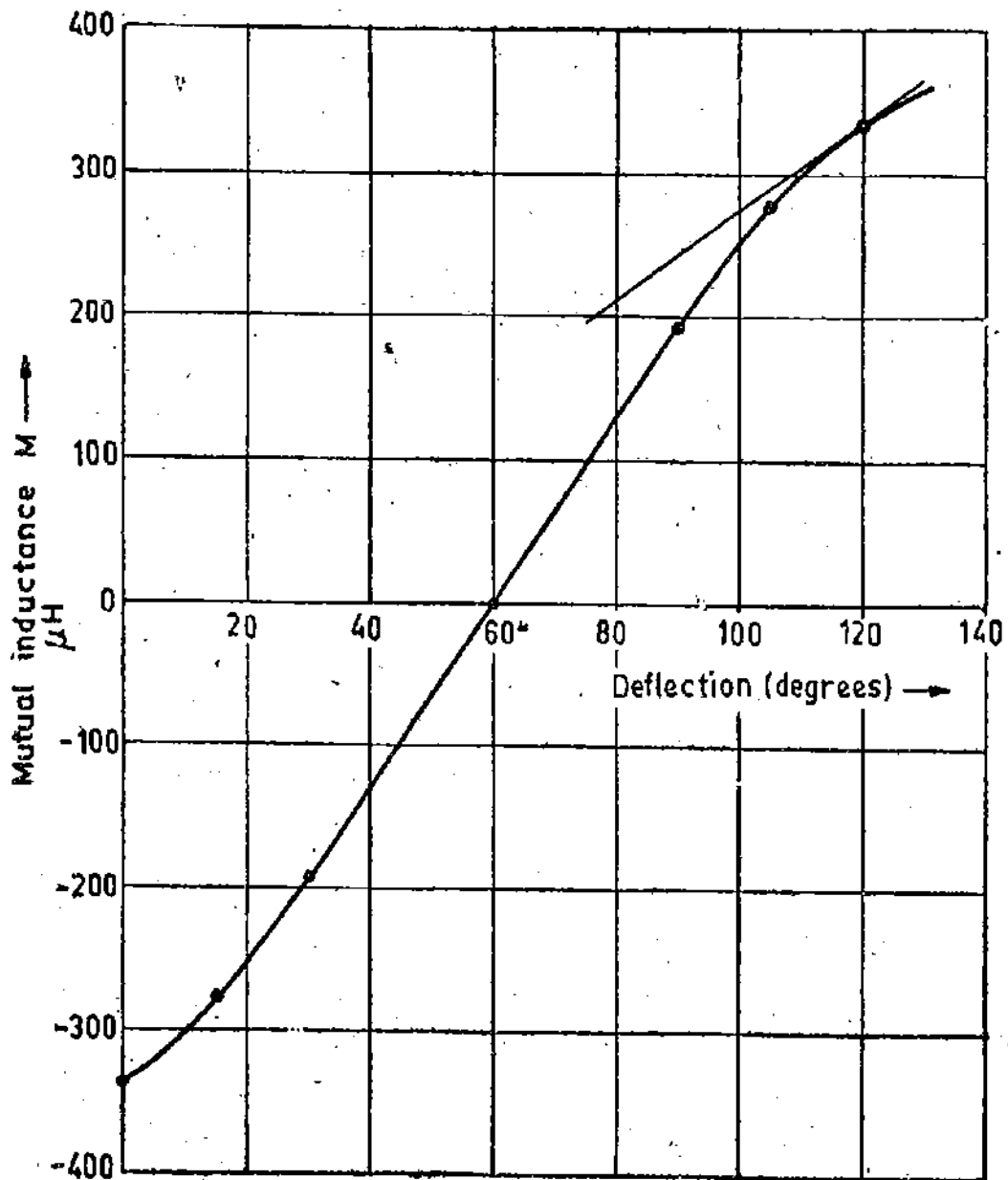

Fig. 8.46

$$\therefore \left(\frac{dM}{d\theta} \right)_{60} = \frac{192 - (-192)}{90 - 30} = 6.4 \mu\text{H/degree} = 366.7 \mu\text{H/rad.}$$

Torque at half full scale $T_a = \frac{1}{2} \times 10.5 \times 10^{-6} = 5.25 \times 10^{-6} \text{ Nm}$

Suppose I = total current

\therefore Current through fixed coil $I_1 = 0.99 I$, Current through moving coil $I_2 = 0.01 I$

Now
$$T_a = I_1 I_2 \frac{dM}{d\theta}$$

$$\therefore 5.25 \times 10^{-6} = 0.99 I \times 0.01 I \times 366.7 \times 10^{-6} \quad \text{or} \quad I = 1.2 \text{ A.}$$

At full scale deflection of 120° , the rate of change of mutual inductance is determined by finding the slope of the curve

$$\left(\frac{dM}{d\theta} \right)_{120} = \frac{336 - 200}{120 - 77} = \frac{136}{43} = 3.16 \mu\text{H/degree} = 181.2 \mu\text{H/rad.}$$

Torque at full scale $T_a = 10.5 \times 10^{-6} \text{ Nm.} \therefore 10.5 \times 10^{-6} = 0.99 I \times 0.01 I \times 181.2 \times 10^{-6}$

or Current $I = 2.42$ A. Full scale deflection $= 120^\circ = 2.09$ rad.

\therefore Spring constant $K = \frac{10.5 \times 10^{-6}}{2.09} = 5.02 \times 10^{-6}$ Nm/rad.

8.52. Ferrodynamic Instruments

With the development in the low loss magnetic materials it is possible to use iron cores in electrodynamic instruments with little loss in accuracy but with a substantial gain in operating torques due to use of increased flux densities.

8.53. Construction. The construction of this instrument is basically similar to electro-dynamometer type but differs from the latter in having a magnetic circuit of soft magnet steel. Refer to Fig. 8.47 for construction. The fixed coil is made up of two halves fitted on an iron core. The moving coil is mounted on a pivoted spindle and is free to rotate about a cylindrical core placed in the air gap of the magnetic circuit. The moving coil is not mounted on a metallic former. This is done to avoid eddy currents. The core is shaped to give a radial field.

8.54. Operation. A radial uniform field proportional to the current carried by the fixed coil is set up in the air gap. The current flowing through the moving coil interacts with the field to produce a torque. The average value of deflecting torque is (See Eqn. 8.3).

8.55. Advantages and Disadvantages

Advantages. (i) The use of iron (a low reluctance material) allows the establishment of a higher flux-density in the air gap and, consequently, a torque much greater than that in air cored electro-dynamometer instruments, is developed. (In fact under identical conditions, the torque developed by a ferrodynamic instrument may be as large as twenty times the torque of an air cored instrument) This increase makes it possible to increase the weight of moving element without any increase in the frictional error and hence a more robust construction can be employed. It is apparent that this instrument is smaller in size and cheaper than the electro-dynamometer type. Also because of robust construction it can withstand greater overloads and mechanical shocks

In fact ferrodynamic type voltmeters with nickel-iron cores are superior to electrodynamic type instruments with iron cores because of their greater inductance and that their effective frequency range may be extended by connecting a capacitor in parallel with a series resistor.

(ii) Due to presence of iron, the effect of external magnetic fields is reduced.

Disadvantages. The employment of steel increases the hysteresis and eddy current losses. Therefore, these instruments have lower accuracy and a lower frequency range than electro-dynamometer type instruments with air cores.

8.56. Electrothermic Instruments

Electrothermic instruments depend for their indication on some property of a circuit element which is heated by flow of current. These instruments are used for measurement of current at high frequencies without any significant errors. In fact their chief field of application is in the measurement of current of frequencies above the range of moving iron and electro-dynamometer type instruments. At moderate frequencies they can be used for precision measurement of voltage.

8.57. Classification.

There are three electro-thermic effects which can be utilised for measurement of current and accordingly there are three types of Electrothermic instruments:

(i) **Hot Wire Instruments.** These instruments utilize the expansion of wire heated by current being measured.

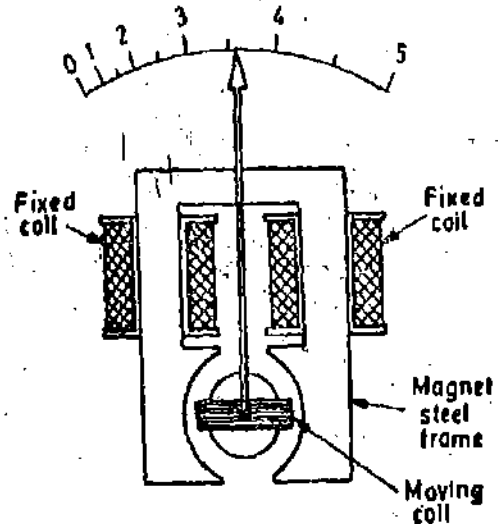

Fig. 8.47. Ferrodynamic instrument.

(ii) *Thermocouple Instruments.* These instruments depend for their action on the emf developed at the junction heated by an auxiliary circuit carrying current being measured.

(iii) *Bolometers.* The change in resistance of a circuit element heated by current being measured is used for operation of these instruments.

8.58. Hot Wire Instruments

The constructional features of a hot wire type instrument are shown in Fig. 8.48. The current to be measured is passed through a fine platinum iridium wire. The wire is stretched between two terminals. A second wire is attached to the fine wire at one end and to a terminal at the other end. A thread is attached to the second wire. This thread passes over a pulley and is fixed to a spring.

When the current is passed through the fine wire it gets heated up and expands. The sag of the wire is magnified and the expansion is taken up by the spring. This causes the pulley to rotate and the pointer to deflect, indicating the value of the current. The expansion is proportional to the heating effect of the current and hence to the square of the rms value of the current. Therefore, the meter may be calibrated to read the rms value of the current.

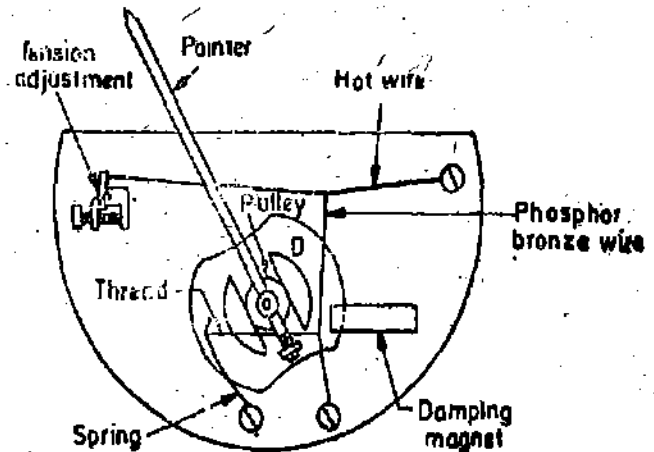

Fig. 8.48. Hot wire instrument.

The instrument has many disadvantages like instability due to stretching of wire, lack of ambient temperature compensation sluggish, response, high power consumption and inability to withstand overloads and mechanical shocks. These disadvantages have made this instrument commercially unsatisfactory. Hot wire instruments are now obsolete and have been replaced by thermo-electric instruments.

8.59. Thermoelectric Instruments

When two metals having different work functions are placed together, a voltage is generated at the junction which is nearly proportional to the temperature. This junction is called a **Thermocouple**. This principle is used to convert heat energy to electrical energy at the junction of two conductors as shown in Fig 8.49.

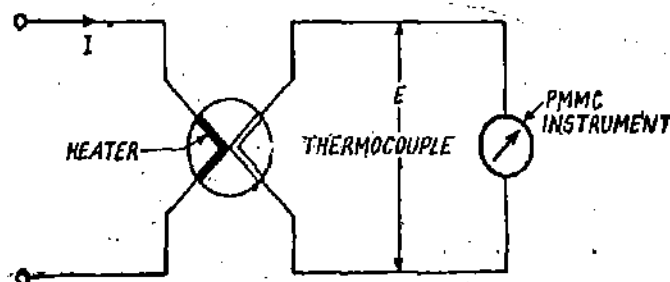

Fig. 8.49. Circuit of a thermo-couple.

The heat at the junction is produced by the electrical current flowing in the heater element while the thermocouple produces an emf at its output terminals which can be measured with the help of a PMMC instrument. The emf produced is proportional to the temperature and hence to the rms value of the current. Therefore the scale of PMMC instrument can be calibrated to read the current through the heater.

8'60. Thermal Emf

The thermal emf developed in a circuit composed of two dissimilar metals with junctions kept at absolute temperatures T_1 and T_2 (with $T_2 > T_1$) may be approximately written as :

$$E = a(T_1 - T_2) + b(T_1 - T_2)^2 \quad \dots(8'73)$$

where a and b are constants whose values depend upon the metals used.

Let $\Delta t =$ difference of temperatures of hot and cold junctions $= T_1 - T_2$

$$\therefore E = a(\Delta t) + b(\Delta t)^2 \quad \dots(8'74)$$

Thus emf of a thermocouple is approximately a parabolic function of the temperature difference between the junctions. The approximate values of constants a and b are :

$a = 40$ to $50 \mu\text{V}$ or more per $^\circ\text{C}$ difference of temperature,

$b =$ few tenths or hundredths of a microvolt

If a temperature difference of 100°C exists between the junctions, an emf of approximately 5 mV will be available. In some instruments, the hot junction has a very high temperature and an emf as high as 15 mV is produced.

8'61. Principle of Operation

The current flowing through the heater element produces heat which is proportional to I^2R , where I is the rms value of the heater current and R is the resistance of the heater element.

Heat produced $\propto I^2R$

The temperature rise over the ambient (room temperature) of the hot junction is proportional to the heat produced.

\therefore Rise in temperature of hot junction $\propto I^2R$.

If the cold junction is maintained at ambient (room) temperature the rise in temperature of hot junction is equal to difference in temperature between hot and cold junctions.

Hence difference in temperature $\Delta t =$ rise in temperature

$$\text{or} \quad \Delta t \propto I^2R \quad \therefore \Delta t = K_1 I^2R$$

This difference in temperature between hot and cold junctions produces an emf (Eqn. 8'74)

$$E = a(\Delta t) + b(\Delta t)^2$$

This value of b is very small as compared with that of a and therefore

$$E \approx a(\Delta t)$$

This emf is fed to a permanent magnet moving coil millivoltmeter which gives a deflection proportional to emf E .

\therefore Deflection of moving coil instrument $\theta = K_2 E = K_2 [a \Delta t + b(\Delta t)^2]$

$$\theta = K_2 a(\Delta t) = K_1 K_2 a I^2 R = K_3 I^2 \quad \dots(8'75)$$

where

$$K_3 = a K_1 K_2 R = \text{a constant.}$$

Hence the instrument shows a square law response.

Actually we do not get an exact square law response as :

(i) the resistance R of the heater element does not remain constant but varies with temperature rise as the element may have a positive or a negative temperature coefficient of resistance,

(ii) the emf is not proportional to first power of temperature difference but is a parabolic function of temperature rise as is clear from Eqn. 8'74.

These effects are usually quite small so that, if the air gap field of permanent magnet moving coil instrument is uniform, the scale of the instrument may be laid off approximately with the square of the heater current.

8'62. Heater Element

The most important application of thermo-electric instruments is for the measurement of current and voltages at high frequencies, and therefore, the heater elements of such instruments should be free from skin effects. In order to minimize the skin effects we must use very fine wire of non-magnetic material having a high resistivity. For example for a 0.025 mm diameter copper wire the increase in resistance is 1 percent at 20 MHz, whereas for constantan wire of the same size the increase in resistance is only 0.0015 percent at 20 MHz and only at 500 MHz does its resistance increase by 1 percent. Thus a fine wire is very suitable as a heater element for measurement of small currents at high frequencies. For measurement of higher values of current (above 3A) a short length of thin walled tubing is used.

8'63. Thermo-element

The action of the thermo-electric instrument is as follows :

- (i) Electrical energy is converted to the thermal energy in the heater element. Most of the heat energy is dissipated away and a portion of it is transferred to the hot junction.
- (ii) The heat energy transferred to the hot junction is converted back to electrical energy by Seebeck effect.
- (iii) The output of the thermocouple is connected to a permanent magnet moving coil instrument. A portion of the electrical energy in the thermocouple circuit is converted to mechanical energy in deflecting the pointer and is stored as potential energy in the springs of the instrument.

The overall efficiency of the system is very low, of the order of a few hundredths of a percent under most favourable circumstances. This means that

- (a) the power consumption of the instrument is relatively high
- (b) a sensitive d.c. instrument has to be used as an indicating element.

The combination of heater element and thermocouple acting as an energy converter is known as a thermo-element. A thermo-element, together with a permanent magnet moving coil instrument constitutes a thermocouple ammeter, milliammeter, or a voltmeter.

The thermo-elements may be of many types :

- (i) **Contact Type.** The contact has a separate heater and the thermocouple has one junction kept in contact with the heater wire as shown in Fig. 8'50. The arrangement is shown for an ammeter. Fig. 8'51 shows the arrangement for a voltmeter.

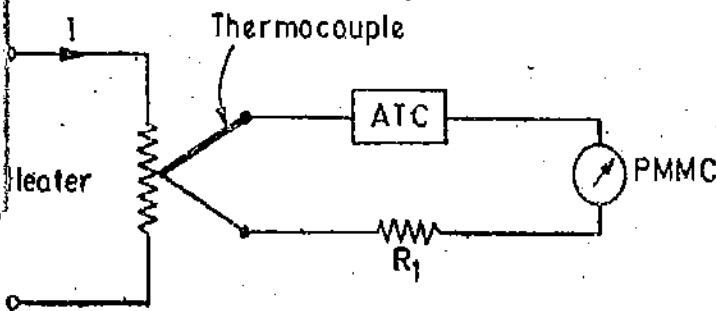

8'50.] Contact type thermo-element. (Ammeter)

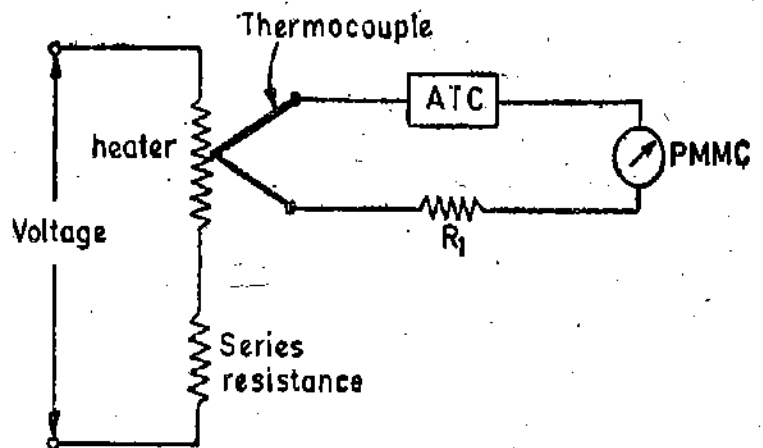

8'51.] Contact type thermo-element. (Voltmeter)

(ii) **Separate type.** In the separate heater type there is no electric contact between the heating element and the thermo-couple, the two being separated by electrical insulation. The heat is conducted from heater to junction across the insulation. This makes the instrument sluggish and less sensitive than the contact type. However, the separation between the heater and the thermo-couple becomes essential for measurement of currents in circuits operated at potentials considerably above the ground potential.

(iii) **Vacuum Thermoelements.** For very low-range thermo-couple instruments, the power absorption is very low. In some cases a power as little as 2 mW is used in the heater element. In order to attain a temperature rise (80° to 100°C) needed to develop the required output in the thermo-couple instrument (about 5 mV on open circuit), we must increase the efficiency and sensitivity of the thermo element. This is done by enclosing both the heater and thermo-couple assembly in a glass tube which is then evacuated (See Fig 8.52). The efficiency is increased because there is no cooling of heater due of convection air currents.

Fig. 8.52 shows an arrangement of separate type where the heater element and the thermo-couple junction are electrically isolated from each other by a bead of insulating material. This is done to minimize the effects of capacitance between the thermo-couple and the rest of the circuit at high frequencies. The insulation creates a very small capacitance between the isolated circuits and is in series with the capacitance from the instrument to ground or to other parts of the circuit. This reduces the capacitive currents which might otherwise be diverted through part of the heater element and produce errors in indication.

The capacitive currents may be considerable part of the total current being measured if the instrument is used for measurement of very small currents. With the advent of new materials, it is now possible to use materials for bead which have very high thermal conductivities. These instruments are very sensitive and have the same response as the contact types for currents upto 100 mA. Another advantage of vacuum type is that the heater element can be operated at much higher temperatures. Vacuum type thermo-couples may be used in the range 2 mA to 500 mA.

Vacuum thermo-couples are suitable for current measurements at frequencies upto 100 MHz or more depending on size and resistivity of wire.

For voltage measurements, very great difficulties are encountered in constructing suitable series resistors for high frequency range. Voltmeters with resistors of usual type are used upto 10 kHz. Special multipliers for low voltages permit measurements at frequencies upto 100 MHz.

(iv) **Bridge Type.** The thermo-couples connected to form a bridge circuit as shown in Fig. 8.53. No heater element is used; instead the current to be measured passes directly through the thermocouples and raises their temperature proportional to I^2R .

The cold junctions are at the pins that are embedded in the bakelite base plate and hot junctions are midway between the pins. The thermo-couples are oriented as shown in Fig. 8.53, so that the resultant thermal emfs give rise to a d.c. difference of potential between *A* and *B*. No a.c. current can flow through the instrument as the bridge is balanced by keeping equal resistance for four arms. This construction gives a greater output than is given by a single thermo-couple used in vacuum and is much more robust in withstanding mechanical shocks and overloads. Bridge type elements are made with a.c. ratings from 100 mA to 1 A. The voltage available may be as much as 25 mV.

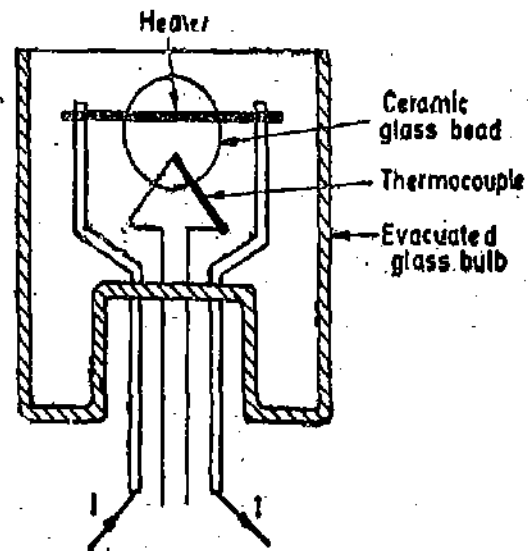

Fig. 8.52. Vacuum thermo-couple.

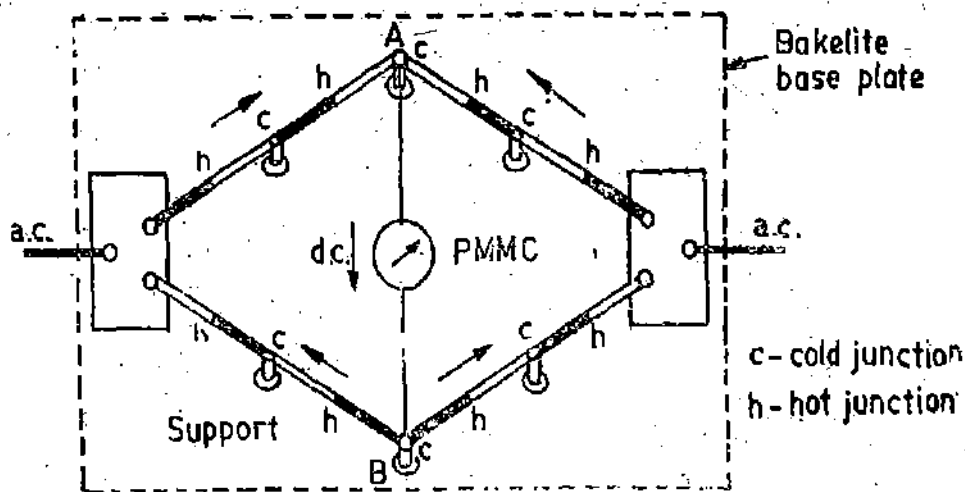

Fig. 8'53. Bridge type thermo-couple instrument.

8'63 Shape of Scale. We have seen that the instrument has a nearly "square law response" i.e.,

$$\theta = K_3 I^2$$

Thus if we use an ordinary permanent magnet moving coil instrument having a uniform air gap, the scale will not be uniform. The scale shape may be modified by suitably shaping the pole faces of the permanent magnet. To obtain a nearly uniform scale, the air gap is made non-uniform in such a way that flux density diminishes as the coil moves up scale. This has been described on page 196

8'64. Connections. For measurement of current, the circuit of Fig. 8'50 is used. The current flowing through the circuit is indicated by a millivoltmeter. Calibration is adjusted with the help of resistance R_1 . In some instruments an automatic temperature compensation circuit (ATC) is used to correct for changes in ambient temperature. The instrument can be converted into a voltmeter by connecting a resistance R in the heater circuit, as shown in Fig. 8'51. Both contact type and separate type of thermo-electric elements may be used for either ammeters or voltmeters.

8'65. Advantages and Disadvantages

Advantages. (i) The thermo-couple instruments correctly indicate the rms value of voltage or current irrespective of the waveform.

(ii) These instruments are not effected by stray magnetic fields.

(iii) These instruments are free from frequency errors and hence they can be used over a very wide frequency range.

In fact they are primarily designed for current measurements at high frequencies. In this application they are superior to any other type of instrument both in accuracy and frequency range.

Their accuracy can be as high as 1% for frequencies upto 50 MHz and can be classified as RF instruments.

(iv) These instruments have a high sensitivity.

(v) They are very useful when used as transfer instruments to calibrate d.c. instruments by potentiometer and standard cell.

Disadvantages. At normal rated current, the heater attains a temperature of 300°C. If we pass twice the rated current the heater would give a temperature of nearly 4 times the normal temperature, i.e., 1200°C. It is obvious that square law rate will bring the heater to nearly its burn out

temperature. Thus it is imperative that the heater be protected against damaging overloads. The fuses do not provide any protection as due to overload the heater wire may burn out before fuse bows out.

Thus the overload capacity of thermo-couple instruments is small as compared with other instruments and is about 150 per cent of the full scale current.

8'66. Ranges. Vacuum type thermo-couples are made in heater ratings between 1.25 mA to 1 A, the current range being doubled at each step. Above 1 A the thermo-elements are no longer in vacuum and are made for currents upto 50 A and the heating element is external to the indicator. Thermo-elements used for current ranges above 50 A are usually provided with air cooling fins.

Multi-range instruments for use in the audio-frequency range can have a single thermo-junction in vacuum, and the current and voltage ranges are changed in a similar manner to that used for d.c. instruments. The resistance of heater element changes slightly for zero to full scale current and some swamping resistance in series with the heater element is necessary when shunts are used for extension of range.

The range of these instruments can also be extended by use of instrument transformers.

Example 8'36. A thermo-electric ammeter is assumed to have a perfect square law response. It gives a full scale deflection for a current of 10 A. Calculate the current which causes half scale deflection.

Solution. The deflection of a thermo-electric ammeter is : $\theta = KI^2$

Suppose θ_F is the full scale deflection. $\therefore \theta_F = K \times (10)^2$ or $\frac{\theta_F}{K} = (10)^2 = 100$

The deflection at half scale is $\frac{\theta_F}{2}$ $\therefore \frac{\theta_F}{2} = KI^2$

or current required to give half scale deflection $I = \left(\frac{\theta_F}{2K}\right)^{\frac{1}{2}} = \left(\frac{100}{2}\right)^{\frac{1}{2}} = 7.07 \text{ A.}$

8'67. Electrostatic instruments

In electrostatic instruments, the deflecting torque is produced by action of electric field on charged conductors. Such instruments are essentially voltmeters, but they may be used with the help of external components, to measure current and power. Their greatest use in the laboratory is for measurement of high voltages.

There are two ways in which the force acts :

(i) One type involves two oppositely-charged electrodes. One of them fixed and the other is movable. Due to force of attraction, the movable electrode is drawn towards the fixed.

(ii) In the other type, there are forces of attraction or repulsion or both between the electrodes which cause rotary motion of the moving electrode.

In both the cases the mechanism resembles a variable capacitor and the force or torque is due to the fact that mechanism tends to move the moving electrode to such a position where the energy stored is maximum.

8'68. Force and Torque Equations. The stored energy is used as a basis for derivation of force and torque equations.

Linear Motion. Referring to Fig. 8'51, plate A is fixed and plate B is movable. The plates are oppositely charged and are restrained by a spring connected to the fixed point. Let a potential difference of V volt be applied to the plates ; then a force of attraction F newton exists between them.

Plate *B* moves towards *A* until this force is balanced by that of the spring. The capacitance between the plates is then *C* farad and the stored energy is $\frac{1}{2} CV^2$ joule.

Now let there be a small increment *dV* in the applied voltage ; then the plate *B* will move a small distance *dx* towards *A*. When the voltage is being increased a capacitive current flows, This current is given by :

$$i = \frac{dq}{dt} = \frac{d}{dt} (CV) = C \frac{dV}{dt} + V \frac{dC}{dt}$$

The input energy is $Vidt = V^2dC + CVdV$

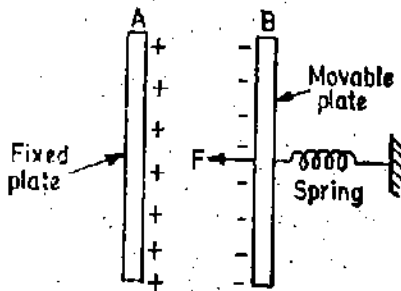

Fig. 8'54.

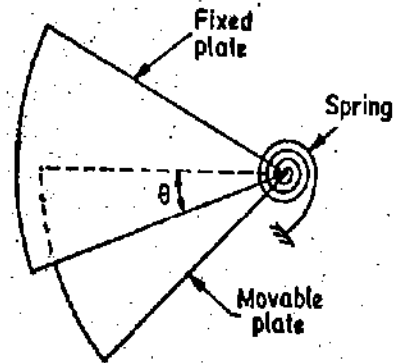

Fig. 8'55.

Illustrating theory of electrostatic instruments.

$$\begin{aligned} \text{Change in stored energy} &= \frac{1}{2}(C+dC)(V+dV)^2 - \frac{1}{2}CV^2 \\ &= \frac{1}{2}(C+dC)(V^2 + \frac{1}{2}VdV + dV^2) - \frac{1}{2}CV^2 = \frac{1}{2}V^2dC + CVdV \end{aligned}$$

neglecting the higher order terms in small quantities.

From the principle of the conservation of energy,

Input electrical energy = increase in stored energy + mechanical work done

$$\text{or } V^2dC + CVdV = \frac{1}{2}V^2dC + CVdV + F dx \quad \therefore F = \frac{1}{2}V^2 \frac{dC}{dx} \quad \dots(8'76)$$

Rotational Motion. The foregoing treatment can be applied to the rotational motion by writing an angular displacement θ in place of linear displacement *x* and deflecting torque *T_d* in place of force *F* (See Fig 8'55).

$$\text{Deflecting torque } T_d = \frac{1}{2} V^2 \frac{dC}{d\theta} \text{ newton-metre} \quad \dots(8'77)$$

If the instrument is spring controlled or has a suspension,

Controlling torque $T_c = K\theta$, where *K* = spring constant and θ = deflection.

$$\text{Hence deflection } \theta = \frac{1}{2} \frac{V^2}{K} \frac{dC}{d\theta} \quad \dots(8'78)$$

8'69. Quadrant Electrometer. This instrument is used for measurement of voltages ranging from about 100 V to 20 kV.

Construction. There are four fixed metal quadrants arranged so as to form a shallow circular box with short air gaps between the quadrants (Fig. 8'56). A thin metal vane or needle is suspended in this partially closed box. The needle is of a double sector shape and may be suspended by means of a thread of phosphor bronze or silver quartz. The needle is equidistant from top and bottom quadrants. The needle carries a mirror and the deflection is read off by means of a lamp and scale arrangement.

An alternate arrangement may be mounting the needle on a spindle and the control torque is provided by a spring attached to the spindle. The deflecting torque moves a pointer and the deflection is read on a calibrated scale. Eddy current damping is used.

The principle of vacuum enclosure has also been applied to deflecting electrostatic instruments. This makes it possible to manufacture extremely sensitive and accurate reflecting-type suspended-vane instruments.

It is usual to connect a high resistance in series with an electrostatic voltmeter, particularly if the instrument is of the suspended-vane type. This resistance is used for limiting the current which can flow if there is accidental connection between a vane and a quadrant (e.g. due to a bent vane). Without this precaution the faulty instrument would be a dead short on the supply. The voltage drop across such a resistance is normally negligible, owing to the very small current taken by the instrument. However, it may introduce errors at high frequencies. In order to avoid error, these resistances are short circuited when making high frequency measurements.

Principle of Operation. The fixed quadrants are connected together and the voltage to be measured is applied between the fixed quadrants and the moving needle (Fig. 8'59). Due to charge accumulated, an electrostatic force is set up. With polarities shown in Fig. 8'59, *A* end of the needle is repelled by the fixed quadrant while end *B* is attracted by its adjacent fixed quadrant and hence the needle rotates. The suspension exerts a controlling torque and the needle takes up a position where the deflecting torque is equal to the controlling torque.

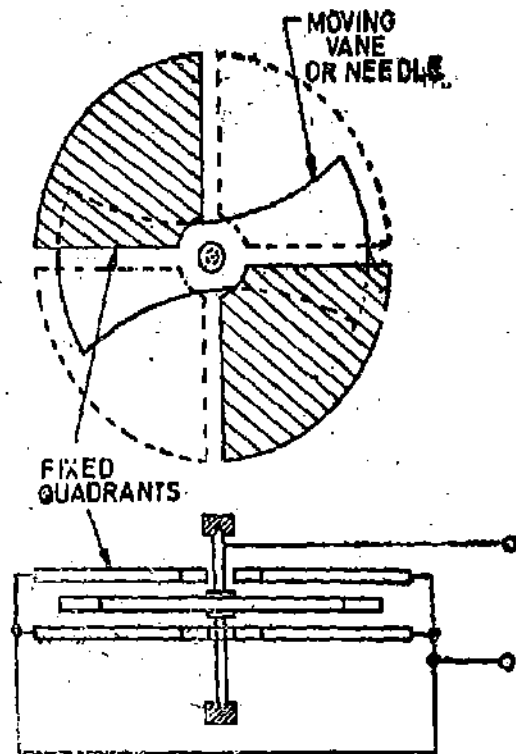

Fig. 8'56. Quadrant Electrometer.

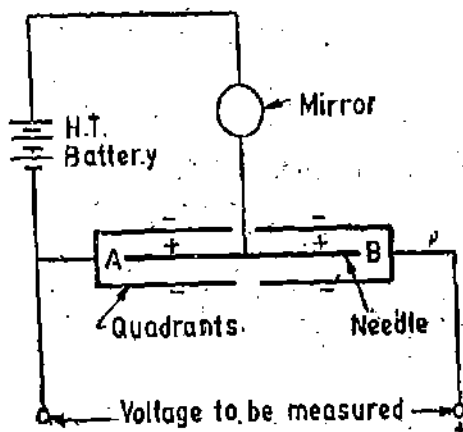

Fig. 8'57

Heterostatic Connection.

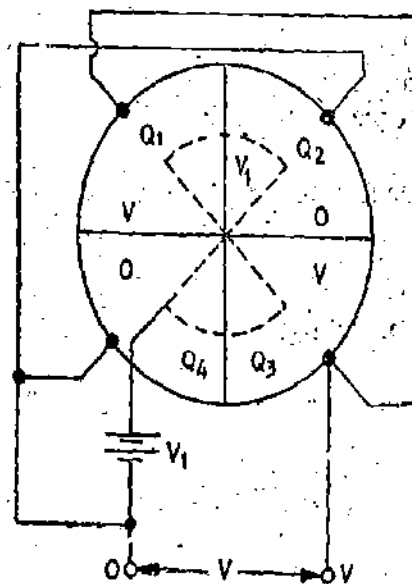

Fig. 8'58

The deflecting torque is proportional to the square of the applied voltage and, therefore, the instrument can be used for both a.c. and d.c.

Types of Connections. The quadrant electrometer may be used in two ways.

1. **Heterostatic Connection.** This connection is shown in Figs. 8'57 and 8'58. A high tension battery is used for charging the needle to a potential considerably above that of the quadrants to which the negative of the voltage to be measured is connected.

2. **Idiostatic Connection.** This connection is shown in Figs. 8'59 and 8'60. The needle is directly connected to one pair of quadrants.

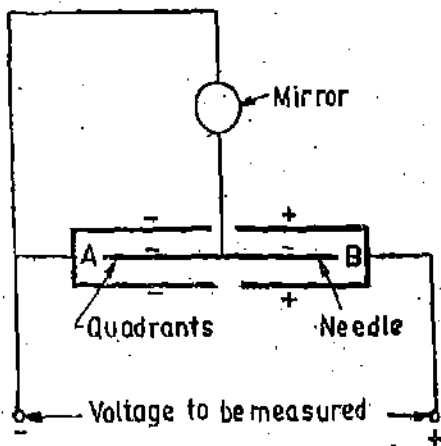

Fig. 8'59 Idiostatic Connection.

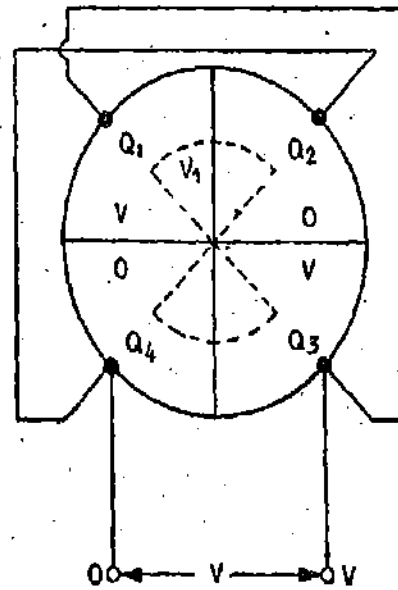

Fig. 8'60

Theory. In order to develop torque equation for an electrometer it is advisable to consider only one half of the needle moving in two quadrants, as shown in Fig. 8'61. The firm lines show the needle at zero position while the dotted lines show it deflected through an angle θ .

The needle is considered to be a sector of a circle having a radius r and spanning an angle 2α . Now we have an arrangement wherein the needle and quadrants form two capacitors C_1 and C_2 lying side by side.

At zero position, these capacitors C_1 and C_2 have equal capacitances as the needle is symmetrically placed with respect to the two quadrants. But when the needle deflects it is no longer symmetrical with the two quadrants and hence capacitance C_1 and C_2 change, one becoming greater than the other.

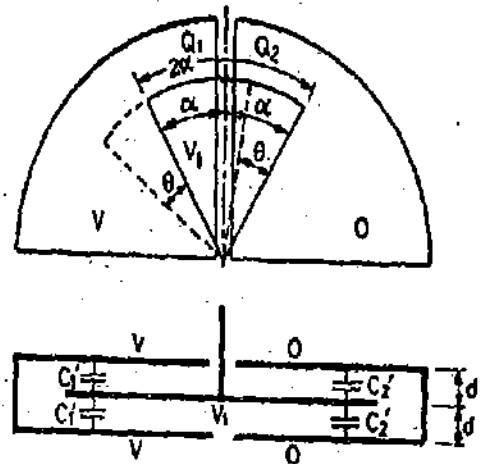

Fig. 8'61

Let us consider that the instrument is heterostatically connected. We have :

- V_1 = potential of needle,
- V = voltage being measured,
- V = potential of quadrant Q_1 ,
- O = potential of quadrant Q_2 .

Let the needle deflect through an angle θ in the anti-clockwise direction. In this position,

C_1 = capacitance of left hand capacitor, C_2 = capacitance of right hand capacitor.

Now d is the distance of needle from either the top or the bottom plates of the quadrants.

For a parallel plate capacitor

Capacitance $C_1' = \frac{\epsilon A}{d}$, where ϵ = permittivity of medium.

$$\therefore C_1' = \frac{\epsilon \left[\frac{1}{2} (\alpha + \theta) r^2 \right]}{d} = \frac{\epsilon [(\alpha + \theta) r^2]}{2d}$$

This is because the needle spans an angle $(\alpha + \theta)$ under quadrant Q_1 .

Capacitance $C_1 = 2C_1' = \frac{\epsilon}{d} (\alpha + \theta) r^2$

Similarly, Capacitance $C_2 = 2C_2' = \frac{\epsilon}{d} (\alpha - \theta) r^2$

$$\text{Now } \frac{dC_1}{d\theta} = \frac{\epsilon}{d} r^2 \quad \text{and} \quad \frac{dC_2}{d\theta} = -\frac{\epsilon r^2}{d}$$

From Eqn. 8.77, deflecting torque

$$= \frac{1}{2} V^2 \frac{dC}{d\theta} = \frac{1}{2} (V_1 - V)^2 \frac{dC_1}{d\theta} + \frac{1}{2} V_1^2 \frac{dC_2}{d\theta} = \frac{1}{2} \frac{\epsilon r^2}{d} [(V_1 - V)^2 - V_1^2]$$

We have considered only two quadrants and half needle. Considering all the four quadrants and the whole of the needle, the deflecting torque will be doubled. Hence total deflecting torque :

$$T_d = 2 \times \frac{1}{2} \frac{\epsilon r^2}{d} [(V_1 - V)^2 - V_1^2] = \frac{\epsilon r^2}{d} [V(2V_1 - V)] \quad \dots(8.79)$$

The negative sign has been dropped since it only indicates that the direction of rotation is opposite to that which has been assumed.

When potential of needle V_1 is very large as compared to voltage being measured, the above equation may be written as

$$T_d = \frac{2\epsilon r^2}{d} V_1 V \quad \dots(8.80)$$

Deflection

$$\theta = \frac{\epsilon r^2}{Kd} [V(2V_1 - V)] = \frac{2\epsilon r^2}{Kd} V_1 V \quad \dots(8.81)$$

Thus heterostatic connection gives a linear scale response when the potential of needle is very high as compared to that of voltage being measured.

Idiostatic connection. Figs. 8.59 and 8.60 show an idiostatic connection. For idiostatic connection $V_1 = 0$.

Hence from Eqn. 8.79, deflecting torque for this instrument is

$$T_d = \frac{\epsilon r^2}{d} V^2 \quad \dots(8.82)$$

and deflection

$$\theta = \frac{\epsilon r^2}{Kd} V^2 \quad \dots(8.83)$$

$$= K_1 V^2 \quad \dots(8.84)$$

Hence with idiostatic connection, the instrument gives a square law response.

For air as dielectric $\epsilon = \epsilon_0 = 8.85 \times 10^{-12}$ F/m and therefore $\theta = 8.85 \times 10^{-12} \frac{r^2}{Kd} V^2$.

8'70. Kelvin Multicellular Voltmeter. The driving torque in a quadrant electrometer is small and, therefore, this instrument is not suitable as such for measurement of low voltages (the force being proportional to square of voltage). In order to make the operating forces sufficiently large, we increase the number of cells and connect the fixed quadrants in parallel. A cell is quadrant electrometer consisting of four quadrants and one moving needle. As there are a number of cells in the instrument and, therefore, it is known as a multicellular voltmeter. We have to increase the number of cells, as the voltage to be measured decreases ; for example, for a 150 V maximum reading voltmeter 13 cells are used, the number decreasing to one for a 3000 V instrument.

Deflecting torque for a n cell instrument $T_d = n \times \text{torque of one cell} = n \times \frac{\epsilon}{d} r^2 V^2 \dots (8.85)$

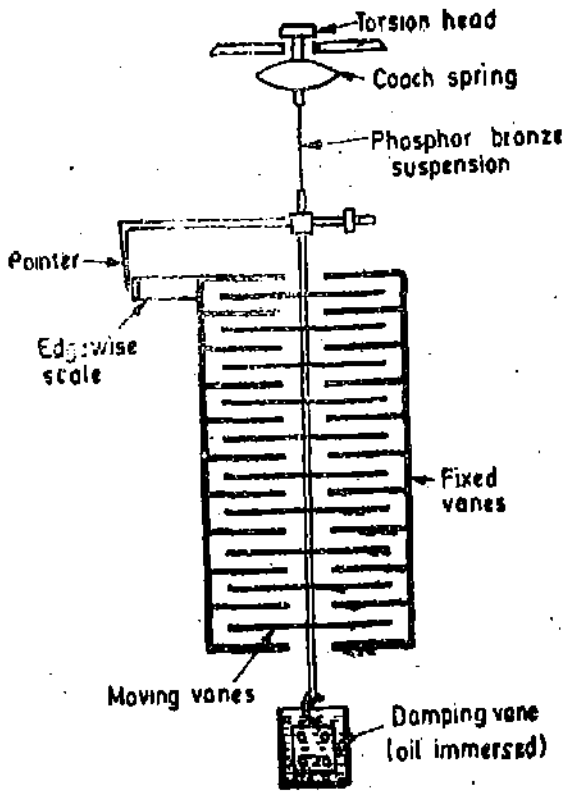

Fig 8'62 Kelvin multicellular voltmeter.

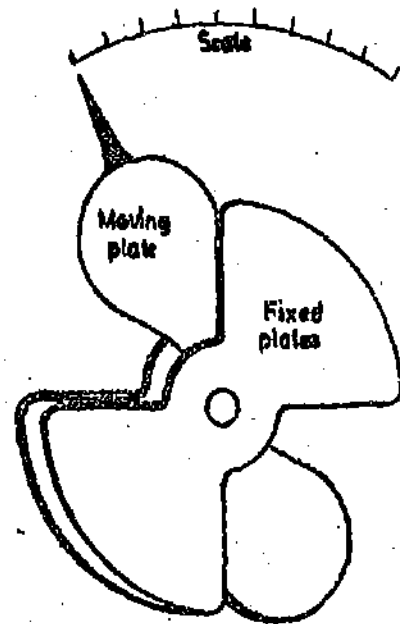

Fig. 8'63. Attraction type portable electrostatic instrument.

Fig. 8'62 shows a 10 cell Kelvin multicellular instrument. There are many constructional features which distinguish it from ordinary quadrant electrometer. A coach spring is used to protect the suspension against vibrations. A torsion head actuated by worm-wheel arrangement, is provided for zero adjustment. The pointer and scale are of edgewise type.

Damping is done by oil dashpot.

8'71. Attraction Type Portable Instruments. The portable electrostatic instruments are generally of the attraction type. The system consists of two sets of plates intermeshed, one set is fixed and other set is free to move as shown in Fig. 8'63. The two fixed and moving plates are insulated from each other and, therefore, the voltage to be measured can be applied across them. This sets up an electrostatic field resulting in a force of attraction which moves the movable plate.

The control is exerted by a spring. Air friction or electromagnetic damping may be provided.

For these instruments :

Deflecting torque $T_d = \frac{1}{2} V^2 \frac{dC}{d\theta}$

Deflection $\theta = \frac{1}{2} \frac{V^2}{K} \cdot \frac{dC}{d\theta}$

8'62. Attracted Disc Type-Kelvin Absolute Electrometer

Construction. It consists of two discs one moving and other fixed. The moving disc is carried by a spring and is suspended from a micrometer head as shown in Fig. 8'64. The moving disc is provided with a guard ring to reduce the fringing effects.

The zero setting of the instrument is done with the help of an optical sighting system.

Operation. The voltage to be measured is applied between the two discs. The moving disc is attracted downwards and is brought back to zero position by turning the micrometer head. The displacement is measured by the micrometer which is calibrated in terms of force. The voltage is then determined in terms of the force and the dimensions of the instrument as is clear from Eqn. 8'87.

Theory. Let

d = distance between plates ; m,

A = area of plates ; m^2 ,

= area of moving plate + $\frac{1}{2}$ area of air gap between moving plate and guard ring,

ϵ = permittivity of dielectric ; F/m,

V = voltage being measured ; V,

F = force between discs ; N.

$$\text{force } F = \frac{1}{2} V^2 \frac{dC}{dx} \quad (\text{See Eqn. 8'76})$$

But for a capacitor with closely spaced plates

$$\frac{dC}{dx} = \frac{C}{d} \quad \text{and} \quad C = \frac{\epsilon A}{d} \quad \therefore F = \frac{1}{2} \epsilon A \frac{V^2}{d^2} \text{ newton} \quad \dots(8'86)$$

$$\text{Hence voltage } V = \sqrt{\frac{2Fd^2}{\epsilon A}} \text{ volt} \quad \dots(8'87)$$

This theory shows that such an instrument will give an absolute determination of potential difference, as the p.d. is given in terms of force and linear dimensions.

The deflecting force is only adequate if the voltage is high. Special construction may be necessary to ensure good insulation, screening, and freedom from corona effects. Instruments of lower accuracy, but working on the same principle, may be arranged to read the voltage directly on a scale being calibrated by comparison with a standard instrument.

The disadvantage of this instrument is that when the voltage being measured is small (a few hundred volt), the two discs should be very near together in order to get an appreciable force. In such cases the measurement of distance between the plates is difficult to carry out. The solution lies in increasing the voltage between fixed and moving plates by using heterostatic connections.

8'63. Everett Edgecumbe Voltmeter. This instrument is a variation of attracted disc type of instrument. It is constructed in different sizes for measurement of voltages of 15 kV to 600 kV.

Construction and Operation. The voltage to be measured is applied between two dome shaped

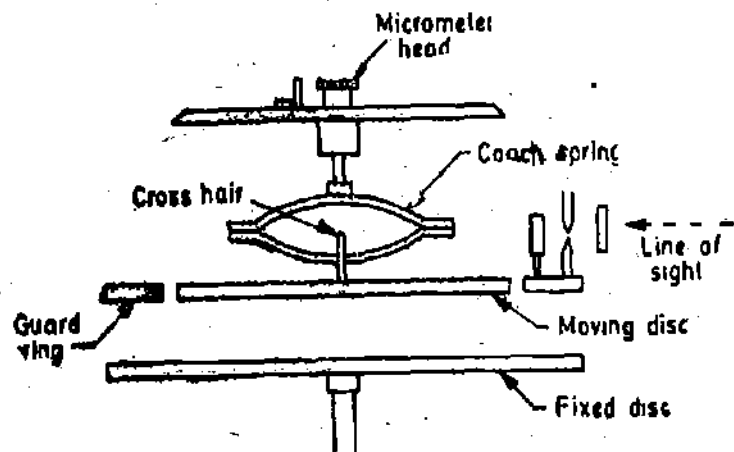

Fig. 8'64. Kelvin absolute electrometer.

electrodes, each mounted on an insulated pedestal. The moving element is an attracted disc set into the face of one electrode (Fig. 8'65). The field between the electrodes causes the disc to move outwards and its motion is transmitted to a pointer through mechanical linkages.

Damping is done with the help of a piston moving in air cylinder.

One of the electrodes is placed on an adjustable mounting which makes it possible to vary the distance between the two electrodes. This variation is done by a rack and pinion arrangement. Thus this design accommodates the construction of multi-range voltmeters by altering the spacing between the two electrodes. This is because a change in spacing alters the capacitance and its rate of change with distance $\left(\frac{dC}{dx}\right)$. The sensitivity is increased by decreasing the distance. A separate scale must be drawn for each voltage range.

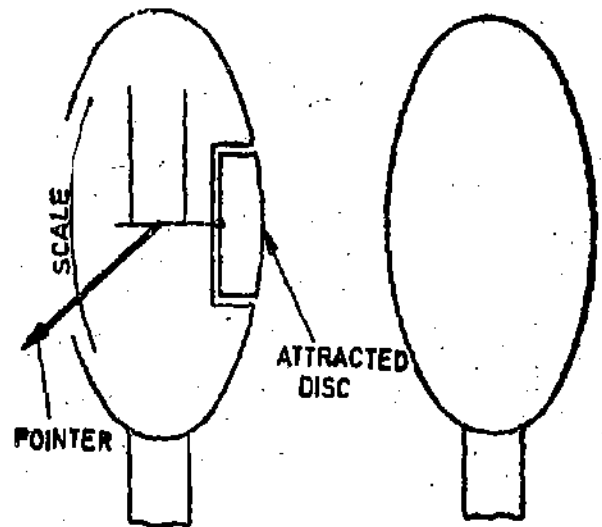

Fig. 8'65. Everett Edgcombe voltmeter.

8'64. Use on both A.C. and D.C. We have seen above that the deflecting force or torque of electrostatic instruments is proportional to square of voltage and hence these instruments can be used for measurement of both a.c. and d.c. voltages. They read the rms value of the a.c. voltage irrespective of the frequency and the wave form.

8'65 Shape of Scale. The deflection is given by $\theta = \frac{1}{2} \frac{V^2}{K} \frac{dC}{d\theta}$

Thus the instrument has a "square law" response and the scale is non-uniform.

In attracted disc type instruments, the change in capacitance with angle $(dC/d\theta)$ may be utilized to have a proper shape for the scale. For example we can make the shape of the discs in such a way that the rate of change of capacitance is inversely proportional to voltage.

i.e.,
$$\frac{dC}{d\theta} \propto \frac{1}{V}$$

\therefore For such a case, deflection $\theta \propto V^2 \times \frac{1}{V} \propto V$.

Hence we can have a linear scale if $\frac{dC}{d\theta} \propto \frac{1}{V}$. In practice, however, this cannot be done

at the lower end of the scale where V is small, so that the scale is always compressed near zero. But in some instruments the scale is made nearly uniform from about 10 or 20 percent of full scale to full scale by suitable design of electrodes.

8'66. General Considerations

1. Instrument Current. The electrostatic instruments are strictly voltage operated devices, in some cases they draw current. This is incidental and not a cause of deflection of these instruments. Their deflection is proportional to the square of the rms value of voltage appearing across their terminals.

When the instrument is first connected to a source of d.c., it draws a momentary charging current which dies away rapidly, the current thereafter being determined by the insulation resistance. The insulation resistance, under good conditions, should be of the order of $10^{12} \Omega$ and even with

considerable humidity it should be of the order of $10^9 \Omega$, so that the electrostatic voltmeter on d.c. can be considered as a zero current device for all practical purposes.

The new nuclear powered batteries, which use a radioactive source in place of chemical action, can be checked by these instruments. Other instruments will give erroneous reading as they draw current from the battery which will result in lowering of their voltage.

One alternating voltage the current is determined by the capacitance of the instrument and the frequency. The operating current increases with frequency as the capacitive reactance ($X_c = 1/2\pi fC$) decreases with increases in frequency. A 15 kV voltmeter having a capacitance of 20 pF requires 100 μ A for full scale deflection at a frequency of 50 Hz. It is fairly simple to extend the range of instruments beyond 200 kV with negligibly small current and power requirements.

2. Operating Forces. The operating forces in electrostatic instruments are very small as compared with electromagnetic and other current operated instruments. This is clear from the energy stored in unit volume of field.

$$\text{Energy density in a magnetic field} = \frac{1}{2} BH = \frac{1}{2} \frac{B^2}{\mu} \text{ joule per m}^3.$$

Considering a magnetic field in air with $B = 0.2 \text{ Wb/m}^2$.

$$\therefore \text{Energy density} = \frac{1}{2} \times \frac{(0.2)^2}{4\pi \times 10^{-7}} \approx 15 \times 10^3 \text{ J/m}^3$$

Energy density in an electrostatic field = $\frac{1}{2} \epsilon e^2$ joule per m^3

Considering an electrostatic field in air with $\epsilon = 1 \text{ MV/m}$ ($\frac{1}{2}$ of breakdown stress of air)

$$\therefore \text{Energy density} = \frac{1}{2} \times 8.85 \times 10^{-12} (1 \times 10^6)^2 = 4.4 \text{ J/m}^3.$$

Thus it is evident that energy density in an electromagnetic field is considerably large as compared with that in an electrostatic field. Hence in order to produce appreciable operating forces the size of electrostatic instruments has to be large.

3. Increasing Operating Forces. The operating forces can be increased by increasing the capacitance. This increase in capacitance can be brought about in three ways:

(i) *Using medium of high permittivity.* The capacitance is increased by immersing the mechanism in a liquid of high permittivity. But this will cause surface tension effects, reduce the resistance and make the instrument non-portable. Some high voltage electrostatic instruments use transformer oil as dielectric medium in order to have a compact design.

(ii) *Using plates of large area.* If we increase the area of plates the capacitance is increased. But this increases the weight of moving parts which will lead to frictional errors. Also the instruments will tend to be sluggish.

(iii) *Using small clearance between plates.* The distance between the plates must be kept small as mechanically and electrically practicable in order to produce a large electrostatic force. But if the distance between the plates is too small, breakdown of the air in the gap will occur which causes loss of power. Also there is possibility of a flash over occurring between charged electrodes which may damage the instrument.

4. Overvoltages. Any individual voltmeter should not be subjected to an overvoltage that is above its maximum calibrated value as there may be a possibility of flash over. Several forms of safety devices are used, the commonest of these being a spark gap fitted in parallel with the charged electrodes and having a spark over-voltage lower than that of the electrodes.

Some instruments use a high value carbon resistance connected in series. This limits the current in case there is a flash over.

5. **Robustness and Sensitivity.** The operating forces are small and hence the pivoting arrangements are often delicate. Therefore, laboratory instruments employ strip suspension instead of bearings and spring control. This improves the sensitivity but the instrument becomes less robust.

6. **Corona.** Corona should be avoided for proper operation of electrostatic instruments. This can be done by rounding off the edges, keeping the voltage gradients below the corona point. Therefore, sometimes we use compressed gas or insulating oil, to keep down voltage gradients and increase operating forces.

7. **Frequency Range.** Theoretically, the frequency range of the electrostatic voltmeter is almost unlimited. There are two phenomena which determine upper limit of frequency :

1. The first is the effect of loading the circuit whose voltage is being measured. The electrostatic voltmeter is small low loss capacitor. Sensitive research voltmeters have a capacitance of 225 pF for 120 V instrument and about 10 pF for 100 kV instrument. As the frequency increases, the reactance of capacitor decreases, and the current drawn by the instrument increases.

2. The second limitation is that the instrument and its leads (because of their inductance) behave like a resonant or partially resonant transmission line at very high frequencies. The network thus formed has standing waves of voltage resulting in non-uniform voltage distributions.

Thus, because of the above two effects, the instrument may not indicate the true value of voltage being measured.

The use of these instruments is limited to frequencies below 100 Hz. However, they may be used at radio frequencies where they are employed for aerial tuning.

8'65. **Extension of Range of Electrostatic Voltmeters.** The voltage range of Electrostatic Voltmeters may be extended by using :

(i) resistance potential dividers, (ii) capacitance potential dividers.

1. **Resistance Potential Divider.** The arrangement of a resistance potential divider for use with an electrostatic voltmeter is shown in Fig. 8'66. The voltage V to be measured is connected across the total resistance R while the electrostatic voltmeter of capacitance C is connected across a portion of the potential divider having a resistance r . For operation on d.c. assuming that the electrostatic voltmeter capacitance C has an infinite leakage resistance, the voltage multiplying factor m of the potential divider is $\frac{R}{r}$.

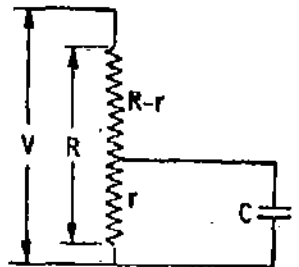

Fig. 8'66. Resistance potential divider.

For operation on a.c. there is shunting effect across the resistance by the capacitive reactance of the voltmeter. The impedance of the parallel combination of voltmeter capacitive reactance and resistance r is :

$$Z = \frac{r \cdot \frac{1}{j\omega C}}{r + \frac{1}{j\omega C}} = \frac{r}{1 + j\omega Cr}$$

The total impedance Z_t connected across the voltage V is thus :

$$Z_t = R - r + \frac{r}{1 + j\omega Cr} = \frac{R + j\omega Cr(R - r)}{1 + j\omega Cr}$$

Thus we have, $\frac{Z_t}{Z} = \frac{R + j\omega Cr(R - r)}{r} = \frac{R}{r} + j[\omega C(R - r)]$

Magnitude of $\frac{Z_t}{Z} = \sqrt{\left(\frac{R}{r}\right)^2 + \omega^2 C^2 (R - r)^2}$

The voltage multiplying factor m is given by the magnitude of ratio Z_t/Z .

$$m = \frac{Z_t}{Z} = \sqrt{\left(\frac{R}{r}\right)^2 + \omega^2 C^2 (R-r)^2} \quad \dots(8'88)$$

$$= \frac{R}{r} \sqrt{1 + \frac{\omega^2 C^2 r^2}{R^2} (R-r)^2} \quad \dots(8'89)$$

As electrostatic voltmeter is normally connected across a small portion of the potential divider and, therefore,

$$\frac{R-r}{R} \approx 1$$

when $\omega^2 C^2 r^2 \ll 1$ or when $r \ll \frac{1}{\omega C}$ We have : $m \approx \frac{R}{r}$... (8'90)

The condition $r \ll (1/\omega C)$ implies that the electrostatic voltmeter will not offer appreciable loading to the portion of potential divider across which it is connected. When r is low, it also follows that the total resistance R of the potential divider will be low for a given value of m . Hence for a given applied voltage V , the power dissipated (V^2/R) would be high. This condition is, therefore, difficult to satisfy in practice especially at high voltages. For this reason the voltage range of resistance potential divider is limited to a few kV only. Resistances used are often oil-immersed.

It should be noted that since resistance potential dividers are to be used on a.c., they should be non-inductively wound.

2. Capacitor Multipliers. The extension of voltage range of an electrostatic voltmeter by the use of a suitable series capacitor is shown in Fig. 8'67(a).

Let C_v be the capacitance of the voltmeter and C_s that of the capacitor in series with it. The impedance Z of the voltmeter is

$$Z = \frac{1}{j\omega C_v}$$

The total capacitance C_t due to series combination of C_s and C_v is

$$C_t = \frac{C_s C_v}{C_s + C_v}$$

Total impedance of the combination is $Z_t = \frac{C_s + C_v}{j\omega C_s C_v}$ $\therefore \frac{Z_t}{Z} = \frac{C_s + C_v}{j\omega C_s C_v} \bigg/ \frac{1}{j\omega C_v} = \frac{C_s + C_v}{C_s}$

Hence the multiplying factor m is given by

$$m = \frac{V}{v} = \frac{Z_t}{Z} = \frac{C_s + C_v}{C_s} = 1 + \frac{C_v}{C_s} \quad \dots(8'91)$$

The voltmeter capacitance C_v varies with deflection (*i.e.*, varies with position of the moving vane) of the voltmeter. Hence an electrostatic voltmeter should be calibrated together with its series multiplier capacitor.

In practice, the capacitor multiplier consists of a set of capacitors connected in series across the voltage to be measured and the electrostatic voltmeter is connected across one of them as shown in Fig. 8'67(b).

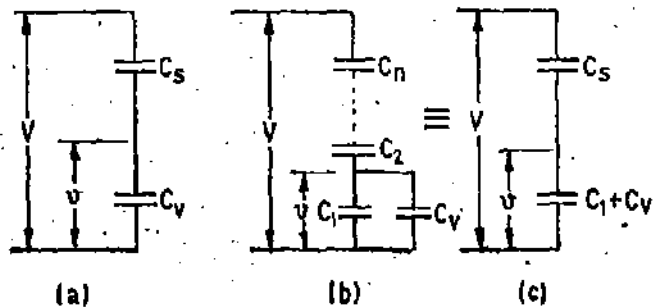

Fig. 8'67. Extension of range by capacitor multipliers.

The resultant parallel capacitance due to C_1 and C_v is $C_1 + C_v$. And the equivalent capacitance C_s in series with this parallel combination is

$$\frac{1}{C_s} = \frac{1}{C_1} + \frac{1}{C_2} + \dots + \frac{1}{C_n}$$

Using Eqn. 8'91, the multiplying factor m is obtained by replacing C_v by $C_1 + C_s$ [See Fig. 8'67 (c)].

$$\text{Hence } m = 1 + \frac{C_1 + C_s}{C_s} \quad \dots (8'92)$$

Again, as C_v varies with deflection, the voltmeter should be calibrated with its multiplier. However, if the capacitance C_1 across which C_v is connected is large compared to the maximum capacitance of the voltmeter, the multiplying ratio may be taken as approximately constant.

8'68. Errors. Electrostatic Instruments are free from errors. Effects due to temperature and frequency are absent. These instruments are not affected by stray magnetic fields but screening has to be provided for stray electrostatic fields.

8'69. Advantages and Disadvantages

Advantages. (i) These instruments draw negligible power from the mains.

(ii) They may be used on both a.c. and d.c.

(iii) They have no frequency and wave-form errors.

(iv) There are no errors caused by stray magnetic fields.

(v) They are particularly suited for high voltages.

Disadvantages. (i) These instruments are expensive, large in size and are not robust in construction.

(ii) Their scale is not uniform.

(iii) The operating forces are small.

Example 8'37. An electrostatic voltmeter reading upto 2000 V is controlled by a spring with a torsion constant of 5×10^{-6} Nm/rad has a full scale deflection of 90° . The capacitance at zero voltage is 15 pF. What is the capacitance when the pointer indicates 2000 V ?

Solution. Deflection $\theta = 90^\circ = \pi/2$ rad.

$$\text{From Eqn. 8'77, final steady deflection } \theta = \frac{1}{2} \cdot \frac{V^2}{K} \cdot \frac{dC}{d\theta}$$

$$\begin{aligned} \text{or rate of change of capacitance } \frac{dC}{d\theta} &= \frac{2\theta K}{V^2} = \frac{2 \times (\pi/2) \times 5 \times 10^{-6}}{(2000)^2} = 3.92 \times 10^{-12} \text{ F/rad} \\ &= 3.92 \text{ pF/rad.} \end{aligned}$$

Change in capacitance when reading from 0 to 2000 V

$$= \frac{dC}{d\theta} \times \theta = 3.92 \times \frac{\pi}{2} = 6.16 \text{ pF}$$

\therefore Capacitance when reading 2000 V, $C = 15 + 6.61 = 21.61$ pF.

Example 8'38. An electrostatic voltmeter is constructed with six parallel, semi-circular fixed plates equi-spaced at 4 mm intervals and five interleaved semi-circular movable plates that move in planes midway between the fixed plates in air. The instrument is spring controlled. If the radius of movable plates is 40 mm, calculate the spring constant if 10 kV corresponds to full scale deflection of 100° . Neglect fringing, edge effects and plate thickness. The permittivity of air is 8.85×10^{-12} F/m.

Solution. Suppose the deflection is θ rad. The fixed and movable plates overlap each other over an angle θ and form a capacitor (See Fig. 8'68).

$$\therefore \text{ Area of plates forming the capacitor } A = \frac{\theta r^2}{2}$$

where

r = radius of movable plate.

Capacitance between fixed and moving plates

$$C = 2 \times \frac{\epsilon A}{d} = 2 \times \frac{\epsilon \theta r^2}{2} \times \frac{1}{d} = \frac{\epsilon \theta r^2}{d}$$

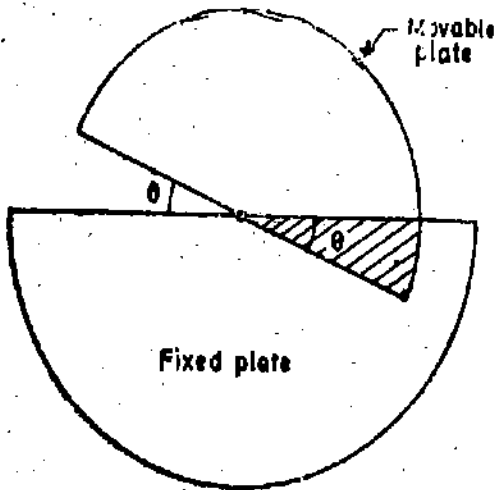

Fig. 8'68

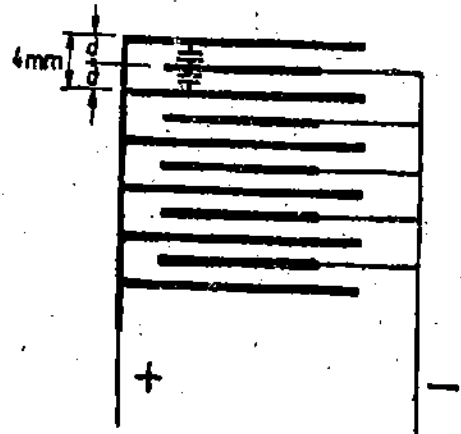

Fig. 8'69

(This is because there are two capacitors, each having a capacitance of $\epsilon A/d$ between fixed and movable plates. The capacitors are in parallel as shown in Fig. 8'69).

$$\frac{dC}{d\theta} = \frac{\epsilon r^2}{d}$$

There are 6 fixed plates and 5 movable plates and hence there are 5 units exerting torque.

$$\text{Torque exerted by each unit} = \frac{1}{2} V^2 \frac{dC}{d\theta} \quad (\text{See Eqn. 8'77})$$

$$\text{Torque exerted by } n \text{ units} \quad T_e = n \times \frac{1}{2} V^2 \frac{dC}{d\theta} = \frac{n}{2} \frac{\epsilon r^2}{d} V^2 = \frac{n}{2} \frac{\epsilon r^2}{d} V^2$$

Let the final steady deflection be θ .

$$\therefore \text{Controlling torque} \quad T_c = K\theta \quad \text{or} \quad K\theta = \frac{n}{2} \frac{\epsilon r^2}{d} V^2$$

$$\therefore \text{Spring constant } K = \frac{n}{2\theta} \frac{\epsilon r^2}{d} V^2 \quad \dots(i)$$

It is given that :

number of units $n=5$, deflection $\theta=100^\circ$, permittivity $\epsilon=8.85 \times 10^{-12}$ (for air)

Separation between fixed plates $2d=4 \text{ mm} \therefore d=2 \text{ mm}=2 \times 10^{-3} \text{ m}$.

Radius of movable plates $=40 \text{ mm}=40 \times 10^{-3} \text{ m}$, Voltage $V=10 \text{ kV}=10 \times 10^3 \text{ V}$

Substituting these values in (i), we have

$$\text{Spring constant } K = \frac{5}{2 \times 100} \times \frac{(8.85 \times 10^{-12}) \times (40 \times 10^{-3})^2 \times (10 \times 10^3)^2}{2 \times 10^{-3}}$$

$$= 17.7 \times 10^{-6} \text{ N-m/degree.}$$

Example 8'39. In an electrostatic voltmeter the full scale deflection is obtained when the moving plate turns through 90° . The torsional constant is $10 \times 10^{-6} \text{ N-m/rad}$. The relation between the angle of deflection and capacitance between the fixed and moving plates is given by

Deflection degree	0	10	20	30	40	50	60	70	80	90
Capactance pF	81.4	121	156	189.2	220	246	272	294	316	334

Find the voltage applied to the instrument when the deflection is 90°.

Solution. The graph between capacitance and deflection is drawn as shown in Fig. 8.70.

The rate of change of capacitance at $\theta=90^\circ$ is found by drawing a tangent to the curve at that point

$$\frac{dC}{d\theta} = \frac{bc}{ab} = \frac{370-250}{100-44} = 1.81 \text{ pF/deg} = 103.5 \text{ pF/rad.}$$

Spring constant $K=10 \times 10^{-6} \text{ N}\cdot\text{m/rad} = 0.1745 \times 10^{-6} \text{ N}\cdot\text{m/deg.}$

Now
$$\theta = \frac{1}{2} \frac{V^2}{K} \frac{dC}{d\theta}$$

or applied voltage

$$V = \sqrt{\frac{2K\theta}{dC/d\theta}} = \sqrt{\frac{2 \times 0.1745 \times 10^{-6} \times 90}{103.5 \times 10^{-12}}} = 552 \text{ V.}$$

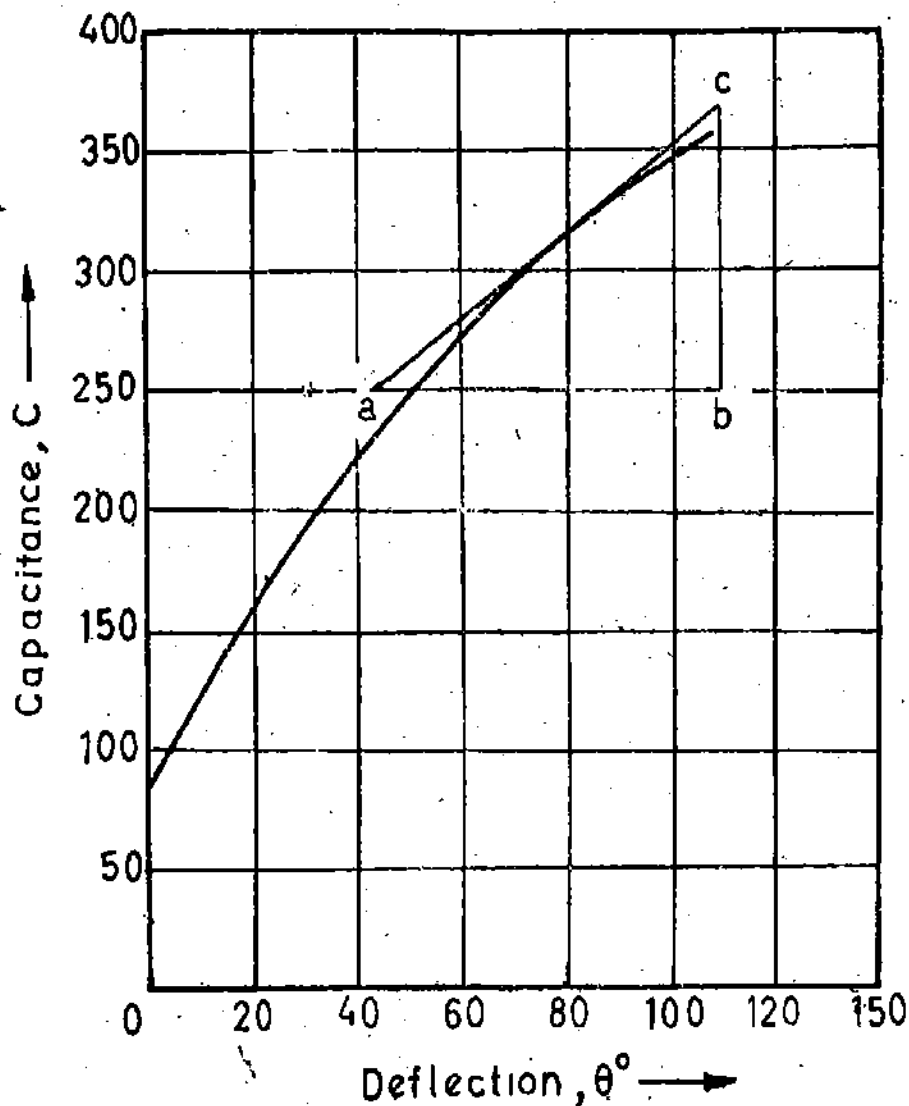

Fig. 8.70

Example 8'40. The movable vane of a quadrant electrometer turned through 25 scale divisions when idiostatically connected to a potential difference of 60 V. When used heterostatically with the quadrants connected to a small voltage V and the needle connected to 900 V supply, the deflection was 10 scale divisions. Determine V .

Solution : From Eqn. 8'82, deflection for idiostatic connection

$$\theta = \frac{\epsilon r^2}{d} V^2 \quad \dots(i)$$

and from Eqn. 8'81 deflection for heterostatic connection $\theta = 2 \frac{\epsilon r^2}{d} V_1 V$..(ii)

where V = voltage being measured, and V_1 = voltage of needle.

Substituting the data given, we have: $\frac{25}{10} = \frac{(60)^2}{2 \times 900 \times V}$ \therefore Voltage $V = 0.8$ volt.

Example 8'41. An absolute electrometer has a movable circular plate 80 mm in diameter. If the distance between the plates during a measurement is 4 mm, find the potential difference when the force of attraction is 2 gm. The dielectric is air, having a permittivity of 8.85×10^{-12} F/m.

Solution : Force of attraction $F = 0.2 \text{ gm} = 0.2 \times 10^{-3} \times 9.81 \text{ N} = 1.962 \times 10^{-3} \text{ N}$.

Distance between plates $d = 4 \text{ mm} = 4 \times 10^{-3} \text{ m}$.

Area of plates $A = \frac{\pi}{4} \left(\frac{80}{1000} \right)^2 = 5.03 \times 10^{-3} \text{ m}^2$.

From Eqn. 8'87,

$$\text{Voltage } V = \sqrt{\frac{2Fd^2}{\epsilon A}} \text{ volt} = \sqrt{\frac{2 \times 1.962 \times 10^{-3} \times (4 \times 10^{-3})^2}{8.85 \times 10^{-12} \times 5.03 \times 10^{-3}}} = 1187 \text{ V.}$$

Example 8'42. An electrostatic voltmeter consists of two attracted plates, one movable, and the other fixed. Both the plates are provided with guard rings so as to make edge effects negligible. It is observed that the application of 10 kV between the plates results in a pull of 5×10^{-3} N on the movable plate. Find the change in capacitance resulting from change in position of the movable plate by 1 mm. Diameter of movable plate is 100 mm.

Solution : Area of movable plate $A = \frac{\pi}{4} \times (100 \times 10^{-3})^2 = 7.85 \times 10^{-3} \text{ m}^2$

Voltage $V = 10 \text{ kV} = 10 \times 10^3 \text{ V}$. Force $F = 5 \times 10^{-3} \text{ N}$.

Distance between plates (See Eqn. 8'87),

$$d = \sqrt{\frac{\epsilon A}{2F}} \cdot V = \sqrt{\frac{8.85 \times 10^{-12} \times 7.84 \times 10^{-3}}{2 \times 5 \times 10^{-3}}} \times 10 \times 10^3 \text{ m} = 26.4 \text{ mm.}$$

Capacitance of a parallel plate capacitor $C = \frac{\epsilon A}{d}$

Now d changes from $d_1 = 26.4 \text{ mm}$ to $d_2 = (26.4 - 1) = 25.4 \text{ mm}$.

\therefore Change in capacitance $= \epsilon A \left(\frac{1}{d_2} - \frac{1}{d_1} \right)$

$$= 8.85 \times 10^{-12} \times 7.84 \times 10^{-3} \left(\frac{1}{25.4 \times 10^{-3}} - \frac{1}{26.4 \times 10^{-3}} \right) \text{ F} = 0.103 \text{ pF.}$$

The change in capacitance may be found as under :

Rate of change of capacitance with distance (See Eqn. 8.78)

$$\frac{dC}{dx} = \frac{2F}{V^2} = \frac{2 \times 5 \times 10^{-3}}{(10 \times 10^3)^2} \text{ F/m} = 100 \text{ pF/m.}$$

$$\text{Change of capacitance} = \frac{dC}{dx} \times \text{distance moved} = 100 \times 10^{-12} \times \frac{1}{1000} = 0.1 \text{ pF.}$$

This result does not tally with the earlier one. The reason is that the rate of change of capacitance is not uniform over the small distance (1 mm) moved by the movable plate.

✓ **Example 8.43.** An electrostatic voltmeter is composed of three square plates of 250 mm side. Two are fixed 100 mm apart in air and are electrically connected. Between this pair and the third which can move into the space between them, a potential difference is applied. With 12 kV, the movable plate is one quarter way in and with 32 kV, it is half way in. What potential difference is required to pull the plate three quarter way in? Neglect fringing and assume that the displacement of the plate produces a proportional control force. The permittivity of air is 8.85×10^{-12} F/m.

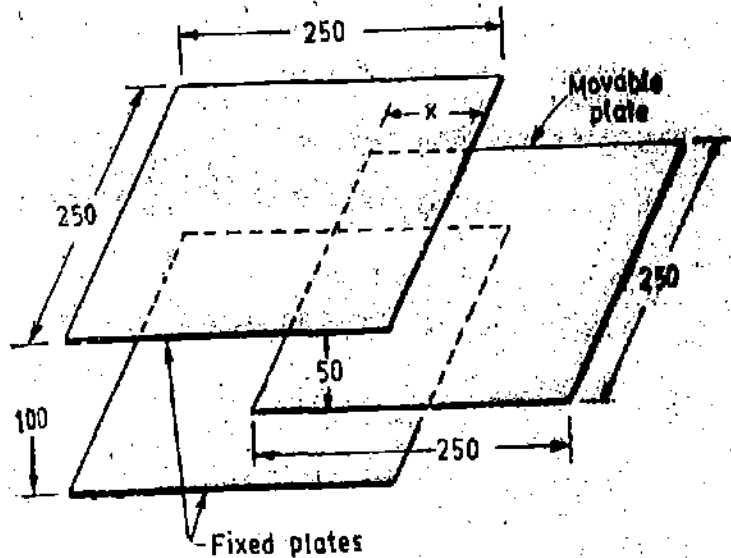

Fig. 8.71

Solution. The arrangement of plates is shown in Fig. 8.71 when the movable plate has moved in a distance x mm.

Area of plates :

$$A = 250 \times x \text{ mm}^2 \\ = 250 \times 10^{-6} \text{ m}^2$$

Distance between plates $d = 50 \text{ mm} = 50 \times 10^{-3} \text{ m}$

The capacitance of the arrangement is

$$C = \frac{2\epsilon A}{d} \text{ (Since there are two capacitors in parallel)} \\ = \frac{2 \times 8.85 \times 10^{-12} \times 250 \times 10^{-6}}{50 \times 10^{-3}} = 0.0885 \times 10^{-12} \text{ F.}$$

Rate of change of capacitance $\frac{dC}{dx} = 0.0885 \times 10^{-12} \text{ F/mm} = 88.5 \times 10^{-12} \text{ F/m.}$

Let x_0 be the initial displacement in mm. \therefore Net displacement $= x - x_0$.

$$\text{Hence, } x - x_0 = \frac{1}{2} \frac{V^2}{K} \frac{dC}{dx}$$

For $V = 12 \text{ kV} = 12000 \text{ V}$, $x = \frac{250}{4} = 62.5 \text{ mm.}$

$$\therefore 62.5 - x_0 = \frac{1}{2} \times \frac{(12000)^2}{K} \times 0.0885 \times 10^{-12} = \frac{6.37}{K} \times 10^{-9}$$

For $V = 32 \text{ kV} = 32000 \text{ V}$, $x = \frac{250}{2} = 125 \text{ mm.}$

$$\therefore 125 - x_0 = \frac{1}{2} \times \frac{(32000)^2}{K} \times 0.0885 \times 10^{-12} = \frac{45.3}{K} \times 10^{-8} \quad \dots (ii)$$

From (i) and (ii), $x_0 = 52.3$ mm and $K = 0.623 \times 10^{-6}$ N/m.

Suppose the voltage applied for a displacement $x = \frac{3}{4} \times 250 = 187.5$ mm is V .

$$\therefore 187.5 - 52.3 = \frac{1}{2} \times \frac{V^2}{0.623 \times 10^{-6}} \times 0.0885 \times 10^{-12} \quad \text{or } V = 43700 \text{ V} = 43.7 \text{ kV.}$$

Example 8'44. The capacitance of a 0–2,000 V electrostatic voltmeter increases uniformly from 42 to 54 pF from zero to full scale deflection. It is required to increase the range of the instrument to 20,000 V by means of an external capacitor. Calculate the value of capacitance required.

Also calculate the area of a pair of plates of an air capacitor suitable for the purpose, assuming distance between the plates = 25 mm. If the capacitor is adjusted to make the full-scale reading correct, what will be per cent error at half-scale reading?

Solution: Multiplying factor $m = \frac{20,000}{2,000} = 10$.

Capacitance of voltmeter at full scale $C_v = 54$ pF.

The multiplying factor with an external capacitance C_s at the full-scale value

$$m = 1 + \frac{C_v}{C_s} \quad (\text{See Eqn. 8'91}) \quad \text{or } 10 = 1 + \frac{54}{C_s}$$

\therefore Capacitance of series capacitor $C_s = \frac{C_v}{m-1} = \frac{54}{10-1} = 6$ pF.

$$\text{Capacitance } C = \frac{\epsilon A}{d} \quad \text{and } \therefore 6 \times 10^{-12} = \frac{8.85 \times 10^{-12} A}{25 \times 10^{-3}}$$

\therefore Area of plates $A = 0.01694 \text{ m}^2 = 16940 \text{ mm}^2$.

The value of the capacitance of voltmeter at half-scale reading = $\frac{54+42}{2} = 48$ pF.

\therefore Multiplying factor at half scale $m = 1 + \frac{48}{6} = 9$.

Reading indicated by voltmeter at half-scale = $\frac{20,000}{2} = 10,000$ V.

Actual reading of voltmeter = $9 \times 1000 = 9000$ V.

Percentage error = $\frac{10,000 - 9000}{9000} \times 100 = 11.1\%$ high.

8'70. Induction Type Instruments

Ammeters and voltmeters which depend upon magnetic induction for the operation are suitable for a.c. measurements only. In fact they have very serious disadvantages which outweigh their advantages and hence induction instruments are not used as ammeters or voltmeters. The induction principle finds its widest application in energy meters as discussed in Chapter 11.

8'69. Principle of Operation. Let us first consider the torque produced by interaction of a flux and a current. Let their instantaneous values be:

$$\phi = \Phi_m \sin \omega t, \quad i = I_m \sin (\omega t - \alpha) \quad (\text{See Fig. 8'72}).$$

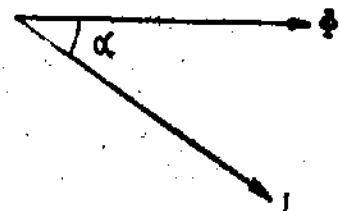

Fig. 8'72

The instantaneous torque is proportional to the product of the instantaneous current and the instantaneous flux.

\therefore Instantaneous torque $\propto \phi i \propto \Phi_m I_m \sin \omega t \sin (\omega t - \alpha)$.

The mean torque over a cycle having a time period T ,

$$T_d \propto \frac{1}{T} \int_0^T \Phi_m I_m \sin \omega t \sin (\omega t - \alpha) dt, \quad \propto \Phi_m I_m \frac{1}{2\pi} \int_0^{2\pi} \sin \theta \sin (\theta - \alpha) d\theta, \quad \propto \frac{\Phi_m I_m}{2} \cos \alpha$$

$$\alpha \Phi I \cos \alpha \quad \dots(8.93)$$

where $\Phi = \frac{\Phi_m}{\sqrt{2}}$ = rms value of flux, $I = \frac{I_m}{\sqrt{2}}$ = rms value of current.

In all induction instruments we have two fluxes produced by currents flowing in the windings of the instrument. These fluxes are alternating in nature and so they produce emfs in a metallic disc or a drum provided for the purpose. These emfs in turn circulate eddy currents in the metallic disc or the drum.

Fig. 8.73 shows a thin circular aluminium disc free to rotate about an axis through its centre. There are two poles P_1 and P_2 producing alternating fluxes ϕ_1 and ϕ_2 which cut the disc. Any annular portion of the disc with centre on the axis P_1 will be linked by alternating flux ϕ_1 , hence it will have an induced emf and this induced emf will produce an eddy current i_1 . Similarly flux ϕ_2 will produce an eddy current i_2 .

Thus we have two fluxes and two eddy currents, and therefore, two torques are produced by :
(i) first flux interacting with eddy current produced by the second flux,

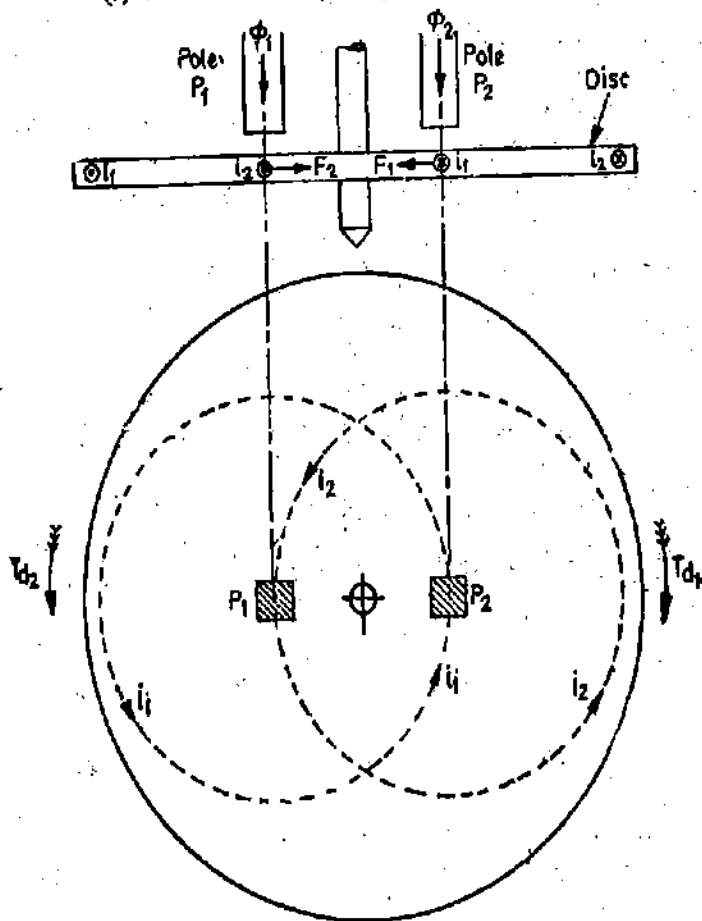

Fig. 8.73. Principle of working of an induction type instrument.

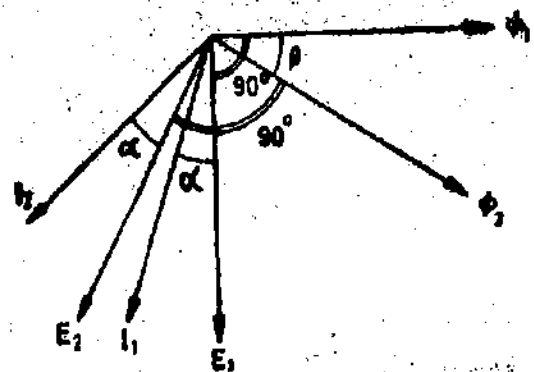

Fig. 8.74. Phasor diagram of an induction type instrument.

and (ii) second flux interacting with eddy current produced by the first flux.

Total torque is the sum of these two torques. We now develop an expression for torque :

Let ϕ_1 and ϕ_2 be the instantaneous values of two fluxes having a phase difference of β and, therefore, we can write :

$$\phi_1 = \Phi_{m1} \sin \omega t, \quad \phi_2 = \Phi_{m2} \sin (\omega t - \beta)$$

Their rms values are $\Phi_1 = \frac{\Phi_{m1}}{\sqrt{2}}$ and $\Phi_2 = \frac{\Phi_{m2}}{\sqrt{2}}$.

Flux Φ_1 produces an emf in the disc by transformer action.

The instantaneous value of this emf is

$$e_1 \propto \left[-\frac{d(\Phi_1)}{dt} \right] \propto \left[-\frac{d}{dt} (\Phi_{m1} \sin \omega t) \right], \propto [-\omega \Phi_{m1} \cos \omega t], \propto [-f \Phi_{m1} \cos \omega t].$$

It is clear from above that e_1 lags the flux by 90° .

Let $E_1 =$ rms value of emf e_1 , $\therefore E_1 \propto f \frac{\Phi_{m1}}{\sqrt{2}} \propto f \Phi_1$... (8'94)

This emf circulates an eddy current having an rms value I_1 . If the impedance of eddy current path is Z ,

$$I_1 = \frac{E_1}{Z} \propto \frac{f}{Z} \Phi_1.$$

I_1 lags the voltage E_1 by an angle α .

The angle between Φ_2 and I_1 is $(90^\circ - \beta + \alpha)$. Refer to phasor diagram shown in Fig. 8'74.

\therefore Average torque produced by interaction of Φ_2 and I_1 is (Use Eqn 8'93).

$$T_{a1} \propto \Phi_2 I_1 \cos (90^\circ - \beta + \alpha), \propto \Phi_2 \Phi_1 \frac{f}{Z} \cos (90^\circ - \beta + \alpha). \quad \dots (8'95)$$

Now take flux Φ_2 and proceed in a similar manner. It produces an eddy emf of rms value

$$E_2 \propto f \Phi_2.$$

E_2 lags the flux Φ_2 by 90° , E_2 circulates eddy currents in the same disc. The rms value of eddy current produced by emf E_2 is :

$$I_2 \propto \frac{f}{Z} \Phi_2.$$

This current lags the emf E_2 by an angle α and, therefore, the angle between flux Φ_1 and current I_2 is $(90^\circ + \beta + \alpha)$. (Refer to Fig. 8'74).

Average torque produced by interaction of flux, Φ_2 and current I_2 is

$$T_{a2} \propto \Phi_1 I_2 \cos (90^\circ + \alpha + \beta), \propto \Phi_1 \Phi_2 \frac{f}{Z} \cos (90^\circ + \alpha + \beta). \quad \dots (8'96)$$

Let the positive directions of flux be as shown and assume that, at the instant under consideration, both fluxes are increasing. Application of Lenz's law shows that the directions of currents i_1 and i_2 will be those as indicated in Fig. 8'71.

Applying the left hand rule, we find that the flux Φ_2 interacting with current i_1 produces a force F_1 acting from right to left.

Similarly flux Φ_1 interacting with current i_2 produces a force F_2 acting from left to right and since the two forces are in opposite direction, they produce two torques T_{a1} and T_{a2} acting in different directions.

Thus the total torque is the difference of the two torques or

$$\text{Total deflecting torque } T_d = T_{a1} - T_{a2}$$

$$\alpha \Phi_2 \Phi_1 \frac{f}{Z} \cos(90^\circ - \beta + \alpha) - \Phi_2 \Phi_1 \frac{f}{Z} \cos(90^\circ + \beta + \alpha)$$

$$\alpha \Phi_2 \Phi_1 \frac{f}{Z} [\sin(\beta - \alpha) + \sin(\beta + \alpha)], \quad \alpha \Phi_1 \Phi_2 \frac{f}{Z} \sin \beta \cos \alpha \quad \dots(8.97)$$

It is clear from Eqn. 8.97 that :

(i) The torque is directly proportional to $\cos \alpha$. Therefore, in order that the torque may be large angle α should be as near zero as possible. Hence, the path of eddy currents should be highly resistive in order that the torque be large.

(ii) The torque is directly proportional to $\sin \beta$. Therefore, angle β should be as near 90° as possible in order that the torque be large. Angle β is the angle between two fluxes and hence the two fluxes should be displaced by an angle as near 90° as possible. Maximum torque is achieved when $\beta = 90^\circ$ i.e., when the two fluxes are displaced by 90° .

8.72. Types of Instruments. As discussed above, the two fluxes must be displaced from each other as near to 90° as possible. There are two ways in which we can achieve this displacement and the type of instruments based upon that are :

- (i) Ferraris type,
- (ii) Shaded pole type.

8.73. Ferraris Type

Construction and Working. The instrument consists of a stationary laminated magnet system consisting of two pairs of coils as shown in Fig. 8.75. A choke coil is connected in series with one pair of coils and a very high resistance is connected in series with the other pair of coils. Thus circuit of one of the pairs of coils is highly inductive while that of the other is highly resistive. The two pairs of coils are supplied from the same source and hence the currents through them are displaced by nearly 90° in time. These currents produce two fluxes, which are in phase with the currents producing them (this is strictly true only if we neglect the iron loss) and hence are nearly 90° out of phase. Thus a rotating field is produced and the instrument operates on the principle of an induction motor.

The rotor consists of a laminated iron core on which an aluminium drum is mounted. The revolving field produced by the stator coils induces eddy currents in the aluminium drum and thus a

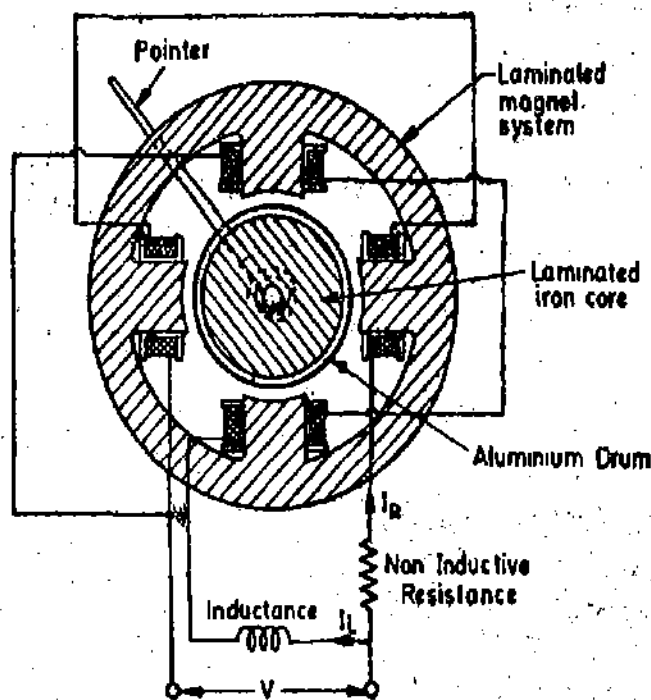

Fig. 8.75. Ferraris type instrument.

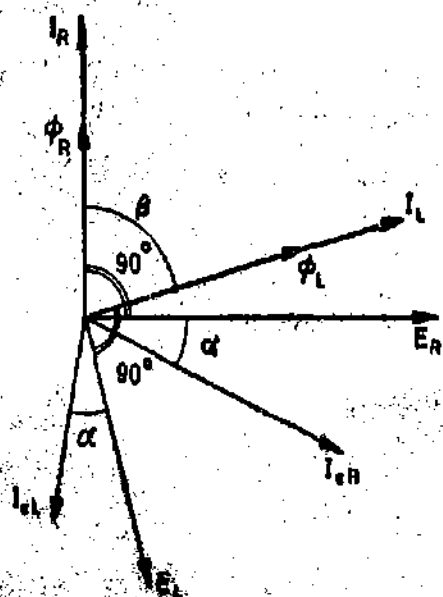

Fig. 8.76. Phasor diagram of Ferraris type of instrument.

torque is produced. Therefore the drum tries to follow the rotation of the revolving field. If the drum were free to rotate, it will revolve in the direction of the revolving field at a speed a little lower than the speed of the revolving field. (The speed of the revolving field is the synchronous speed). But a control spring is provided to exert control and check the rotation so that the deflection is some angle less than 360° , the angle of deflection being determined the deflecting torque and the restoring torque produced by the spring.

The aluminium drum and the laminated iron core are mounted on a spindle which moves in jewelled bearings. A pointer is used for the indication of deflection.

Damping is provided by movement of an aluminium disc in the field of a permanent magnet.

Let I_R = current through the resistive coils, Φ_R = flux produced by resistive coils,

I_L = current through the inductive coils, Φ_L = flux produced by inductive coils.

Now $\Phi_R \propto I_R$ and $\Phi_L \propto I_L$.

From Eqn. 8.97, torque produced is :/

$$T_d \propto \Phi_1 \Phi_2 \frac{f}{Z} \sin \beta \cos \alpha, \quad \propto \Phi_R \Phi_L \frac{f}{Z} \sin \beta \cos \alpha, \quad \propto I_R I_L \frac{f}{Z} \sin \beta \cos \alpha. \quad \dots(8.98)$$

We have I = current being measured for an ammeter,

V = voltage being measured for a voltmeter,

E_R = emf induced by Φ_R ,

I_{eR} = Eddy current produced by E_R ,

E_L = emf induced by Φ_L ,

I_{eL} = eddy current produced by E_L .

The phasor diagram is shown in Fig. 8.76.

Both I_R and I_L are proportional to I , the current being measured for an ammeter. For a voltmeter I_R and I_L are proportional to V , the voltage being measured.

$$T_d \propto I^2 \frac{f}{Z} \sin \beta \cos \alpha \text{ for an ammeter} \quad \dots(8.99)$$

$$\propto V^2 \frac{f}{Z} \sin \beta \cos \alpha \text{ for a voltmeter} \quad \dots(8.100)$$

It is clear from above that the torque is proportional to square of the rms value current (or voltage) being measured.

$$\text{Deflecting torque } T_d = K_1 I^2 \frac{f}{Z} \sin \beta \cos \alpha \quad \dots(8.101)$$

where K_1 is a constant.

If θ is the final steady deflection, controlling torque $T_c = K\theta$
where K is the spring constant.

$$\text{Hence } \theta = \frac{K_1}{K} I^2 \frac{f}{Z} \sin \beta \cos \alpha \quad \dots(8.102)$$

$$= K_2 I^2 \frac{f}{Z} \sin \beta \cos \alpha \quad \dots(8.103)$$

where

$$K_2 = \frac{K_1}{K} = \text{a constant,}$$

8'74. Shaded Pole Type. The instrument has a laminated electromagnet. The poles of the electromagnet are split into two parts. This is done by having a narrow slot which is about $1/3$ the distance from one edge as shown in Fig. 8'77. A heavy section short-circuited copper strip is placed around the smaller of the two areas formed by the slot. This is called a copper shading band and is usually made from an extruded tube of rectangular copper. The portion of pole around which shading band is put is designated as the shaded part of the pole while the free portion is called unshaded part. The electromagnet is provided with an exciting coil which surrounds the whole pole.

Construction. The exciting coil is placed on the poles and a current proportional to current or voltage being measured is passed through it.

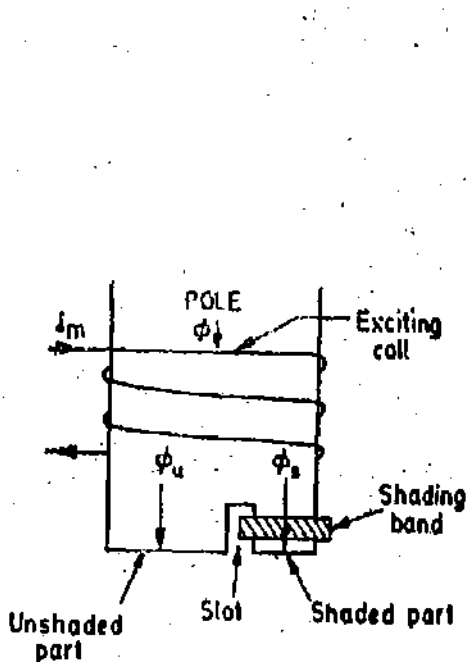

Fig. 8'77. Shaded pole.

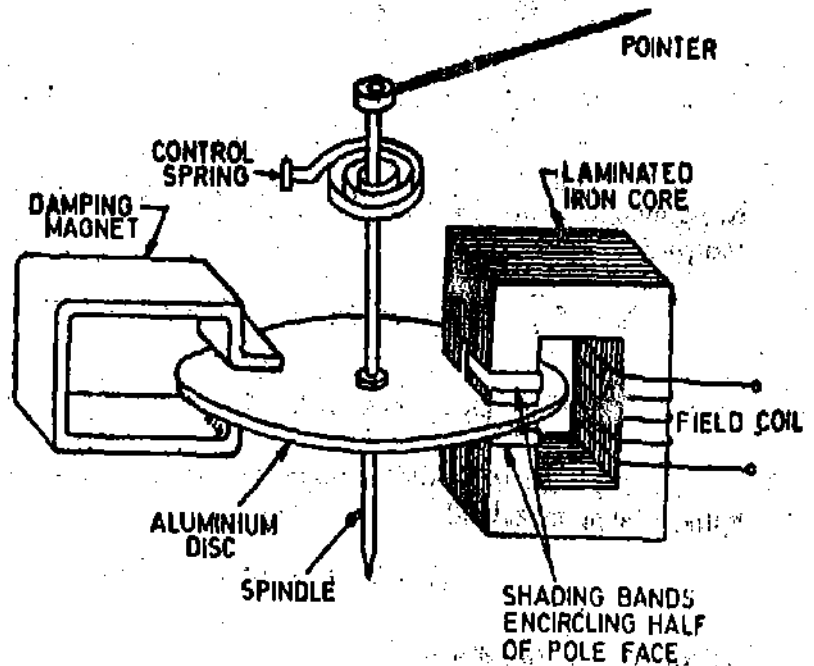

Fig. 8'78. Shaded pole instrument.

The moving system consists of a copper or an aluminium disc which moves in the air gap of the electromagnet. The disc is mounted on a spindle which is pivoted (Fig. 8'78). The control is exerted with the help of a spring. A damping magnet is placed at the opposite side of the electromagnet, so that the disc is used for production of both deflecting and damping torques.

Production of Shifting Field. When the electromagnet exciting coil is supplied with current, it produces a flux. The magnetic axis of flux shifts from the unshaded part to shaded part of the pole. This shift in axis is, in effect, equivalent to an actual physical motion of the pole and, therefore results in production of a torque.

The production of a shifting field is due to difference in flux distributions in shaded and unshaded portions of poles. This difference in distributions may, for simplicity, be attributed to phase shift between the fluxes in the shaded and unshaded portions of the pole. It may be remembered that this difference is due to field produced by eddy currents in the shading band. If the shaded band were open-circuit, there would be no eddy currents in it and hence the fluxes in the two portions would be in phase with each other.

The phase difference between the two fluxes is about 40° to 50° and can be varied by varying the size of the shading band.

Operation. The shifting field produces an emf in the aluminium disc which provides paths for eddy currents to flow. These eddy currents interact with the field to produce a deflecting torque. The disc tries to rotate at a speed little less than the synchronous speed but its motion is checked by the controlling torque produced by the springs. The disc will finally deflect to a position where the deflecting torque is balanced by the controlling torque.

Theory

The phasor diagram of the instrument is shown in Fig. 8.79.

Φ = total flux, Φ_u = flux in the unshaded portion

Φ_s = flux in the shaded portion, E_u = emf induced by Φ_u

E_s = emf induced by Φ_s , I_{eU} = eddy currents produced by E_u

I_{eS} = eddy currents produced by E_s .

From Eqn. 8.97, deflecting torque

$$T_d \propto \Phi_1 \Phi_2 \frac{f}{Z} \sin \beta \cos \alpha$$

$$\propto \Phi_u \Phi_s \frac{f}{Z} \sin \beta \cos \alpha \quad \dots(8.104)$$

Both Φ_u and Φ_s are proportional to I , the current being measured for an ammeter or V , the voltage being measured for a voltmeter.

$$T_d \propto I^2 \frac{f}{Z} \sin \beta \cos \alpha \text{ for an ammeter} \quad \dots(8.105)$$

$$\propto V^2 \frac{f}{Z} \sin \beta \cos \alpha \text{ for a voltmeter} \quad \dots(8.106)$$

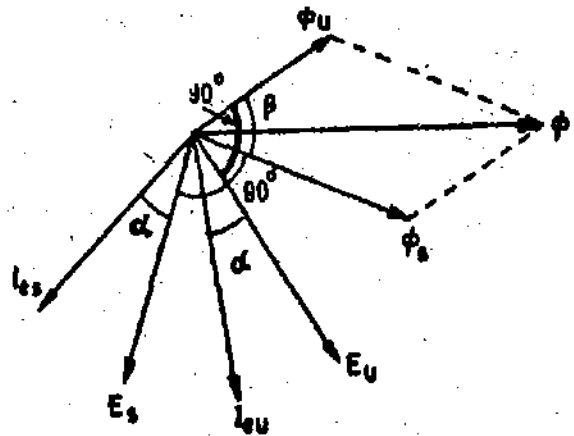

Fig. 8.79. Phasor diagram of a shaded pole instrument.

It is clear from above that the torque is proportional to square of rms value of current or voltage being measured.

$$\therefore T_d = K_1 I^2 \frac{f}{Z} \sin \beta \cos \alpha \quad \dots(8.107)$$

where K_1 is a constant.

$$\text{Final steady deflection } \theta = \frac{K_1}{K} I^2 \frac{f}{Z} \sin \beta \cos \alpha \quad \dots(8.108)$$

$$= K_2 I^2 \frac{f}{Z} \sin \beta \cos \alpha \quad \dots(8.109)$$

8.75. Shape of Scale. From Eqns. 8.103 and 8.109, for both Ferraris and shaded pole types of instruments, for any frequency, we have :

$$\theta \propto I^2$$

and, therefore, the scale is non-uniform and is cramped at the lower end. In the case of shaded pole type of instrument, the shape of scale can be improved by using a cam shaped disc instead of a circular one.

8.76. Advantages and Disadvantages**Advantages**

- (i) A full scale deflection of over 300° can be obtained giving a long open scale.
- (ii) Damping is good.
- (iii) The effect of stray magnetic fields on the readings is small as the operating forces are large.

Disadvantages

- (i) Power consumption is fairly high in these instruments.
- (ii) The cost of instruments is high.

(iii) The large deflection produces large stresses in the springs.

(iv) Serious errors are caused due to changes in frequency and temperature unless properly compensated. Therefore, these instruments are useful only for switch-boards where there is not much variation in frequency.

(v) These instruments are only suitable for a.c.

(vi) The scale is non-uniform.

Example 8.45. An uncompensated shaded pole type of induction instrument is calibrated for 50 Hz. Its deflection is 150° with a current of 10 A. The ratio of resistance to inductance of the aluminium disc eddy current paths is 1500.

Find the deflection of the instrument when measuring 10 A at a frequency of 100 Hz. Comment upon the result.

Solution : The Ratio $\frac{R}{L} = 1500$. $\therefore R = 1500 L$. Suppose $L = n$ henry.

\therefore Reactance of eddy current paths at 50 Hz, $X_1 = 2\pi \times 50 \times n = 314 n \Omega$.

Resistance of eddy current paths $R_1 = 1500 n \Omega$.

Impedance of eddy current paths at 50 Hz, $Z_1 = \sqrt{(1500 n)^2 + (314 n)^2} = 1532.4 n \Omega$.

$$\cos \alpha_1 = \frac{R_1}{Z_1} = \frac{1500 n}{1532.4 n} = 0.978.$$

Reactance at 100 Hz, $X_2 = 2\pi \times 100 n = 628 n \Omega$.

Resistance at 100 Hz, $R_2 = 1500 n \Omega$.

Impedance at 100 Hz, $Z_2 = \sqrt{(1500 n)^2 + (628 n)^2} = 1626.1 n \Omega$.

$$\cos \alpha_2 = \frac{R_2}{Z_2} = \frac{1500 n}{1626.1 n} = 0.922.$$

Now Deflection $\theta = K_2 I^2 \frac{f}{Z} \sin \beta \cos \alpha$ (See Eqn. 8.109)

Deflection with 50 Hz, $\theta_1 = K_2 I^2 \frac{f_1}{Z_1} \sin \beta \cos \alpha_1$

Deflection with 100 Hz, $\theta_2 = K_2 I^2 \frac{f_2}{Z_2} \sin \beta \cos \alpha_2$

(Current I is the same in both cases and β remains the same as long as the shading is the same).

$$\therefore \frac{\theta_2}{\theta_1} = \frac{K_2 I^2 \frac{f_2}{Z_2} \sin \beta \cos \alpha_2}{K_2 I^2 \frac{f_1}{Z_1} \sin \beta \cos \alpha_1} = \frac{Z_1 f_2 \cos \alpha_2}{Z_2 f_1 \cos \alpha_1}$$

\therefore Deflection with 100 Hz and 10 A, $\theta_2 = \theta_1 \times \frac{Z_1 f_2 \cos \alpha_2}{Z_2 f_1 \cos \alpha_1} = 150 \times \frac{1532.4 \times 100 \times 0.922}{1626.1 \times 50 \times 0.978} = 230^\circ$

\therefore Error = $\frac{230 - 150}{150} \times 100 = 53.3$ per cent.

Thus it is clear that the errors caused by frequency in an induction type ammeter will be very large unless properly compensated with connecting a shunt across it. There is an inherent partial compensation in the instrument itself because of increase in the value of impedance of eddy current paths with frequency. In the absence of such an increase the reading should be two times i.e., 300° at 100 Hz if it is 150° at 50 Hz. It is actually 230° due to compensation done by increase in impedance with

increase in frequency. However, this compensation is not sufficient as even with this the error is over 50% and hence it is very serious and has to be compensated for otherwise.

8'77. Rectifier Instruments. Rectifier instruments are used for a.c. measurements by using a rectifier to convert a.c. into a unidirectional d.c. and then to use a d.c. meter to indicate the value of rectified a.c. This method is very attractive, because a PMMC instrument has a higher sensitivity than either the electro-dynamometer type or the moving iron instruments.

Rectifier instruments are particularly suited to measurements on communication circuits and for other light current work where the voltages are low and resistances high. It is essential that for these applications that the current taken by the voltmeters should not exceed say 1 mA in order that there are no loading effects and rectifier instruments satisfy these requirements as they are available in the sensitivity range of 1000 Ω/V to 2000 Ω/V .

8'78. Rectifier Elements. A rectifier element is used to convert the alternating current to direct current or unidirectional current before it flows through the meter. Rectifier type instruments use copper oxide, selenium, doped germanium and silicon crystal diode rectifiers. The copper oxide elements have a peak inverse voltage (PIV) of the order of 2 V and selenium elements have a PIV of about 10 V and also they can handle only limited amounts of current and for these reasons they are becoming obsolete. Germanium diodes have a peak inverse voltage of the order of 300 V and a current rating of approximately 100 mA. Low current silicon diode rectifiers have a PIV of up to 1000 V and a current rating of 500 mA (High-current silicon diodes are seldom used in indicating instruments, but find extensive use in power applications requiring currents as high as 85 A per rectifying element). For these reasons germanium and silicon diodes are being extensively used in modern rectifier instruments.

When low voltage drops in the conducting direction are necessary, germanium diodes are preferred, while silicon diodes are employed when their higher PIV, smaller leakage and low temperature co-efficient are of importance.

8'79. Rectifier Characteristics. An ideal rectifying element would have a current voltage relationship such as shown in Fig. 8'80 *i.e.*, the relationship is linear in the forward direction while

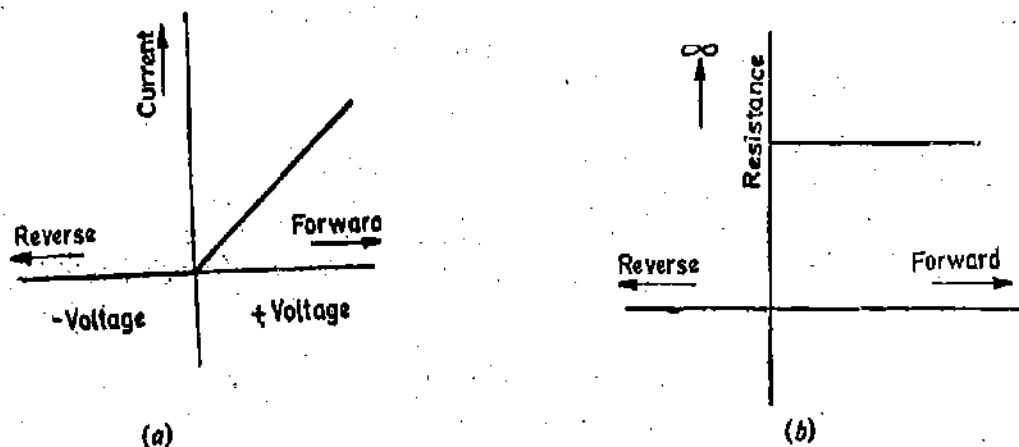

Fig. 8'80. Characteristics of an ideal rectifier element.

no current flows in the backward direction. This means that the rectifier resistance is constant in the forward direction but is infinite in the reverse direction [Fig. 8'81 (b)]. This ideal is not realized in practice. In practice, the rectifier is a non-linear device indicated by characteristics of Fig. 8'81 (a). At low values of forward current the rectifier operates in an extremely low linear part of its characteristic curve, and the resistance is same as compared to resistance at high currents (the resistance decreases with increase in forward current) and also the reverse current is not zero. For a given voltage, the forward current may be as much as 25 times the backward current or even more.

Thus we conclude from above that the resistance of a rectifying element is not constant but is a function of the current.

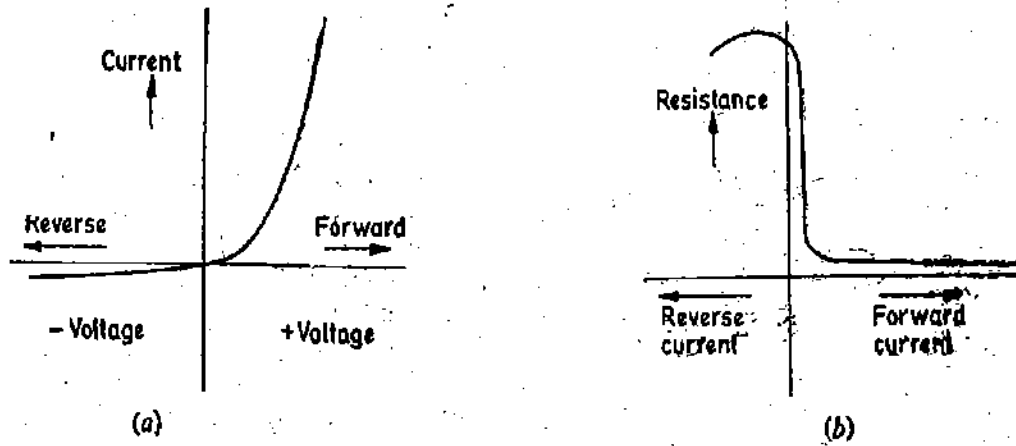

Fig. 8'81. Characteristics of an actual rectifier element.

8'80. Rectifier Voltmeters

8'81. Full Wave Rectifier Circuit. Rectifiers for instrument work sometimes consist of four rectifying elements connected in a bridge configuration, providing full scale rectification. Fig. 8'82 shows an a.c. voltmeter consisting of a multiplier, a bridge rectifier and a PMMC movement.

8'82. Factors Influencing the Performance

The bridge circuit is full wave rectifier producing a pulsating unidirectional output voltage over the complete cycle of the input voltage. Because of the inertia of the moving coil the metre will indicate a steady deflection proportional to the average value of current. For practical purposes since the currents and voltages are expressed in rms values, the meter scale is calibrated in rms value of an alternating sine wave input. A non-sinusoidal waveform has an average value that may differ considerably from the average value of a pure sine wave (for which the meter is calibrated) and the indicated reading may be quite erroneous. The form factor relates the average value and the rms value of time varying voltages and currents :

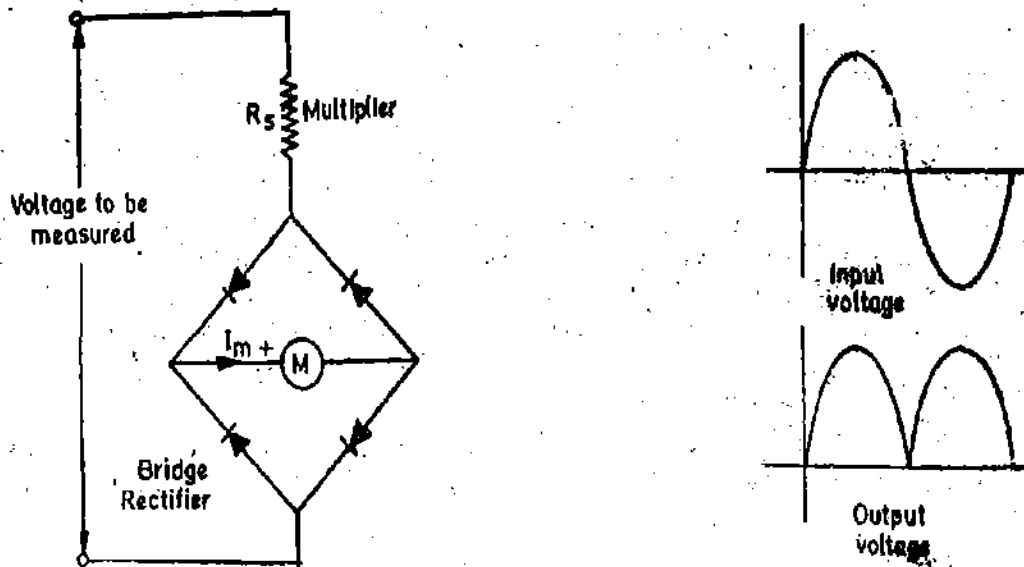

Fig. 8'82. Rectifier voltmeter using bridge rectifier.

$$\text{Form factor} = \frac{\text{rms value of a.c. wave}}{\text{average value of a.c. wave}}$$

$$\text{For a sinusoidal waveform : form factor} = \frac{V_{rms}}{V_{av}} = \frac{V_m/\sqrt{2}}{2V_m/\pi} = 1.11$$

Effect of Wave Form

On the assumption that the current waveforms are sinusoidal the scale of the instrument must be marked in terms of 1.11 times the current actually measured, to give rms values. It is clear

at the outset that these instruments must be subject to considerable waveform errors. A number of current waveforms having the same average value may have rms values which may vary considerably, but in all cases the rectifier instruments will indicate 1.11 times the average value.

Effect of Rectifier Resistance

The effect of non-linear current voltage relationships of rectifier elements (as explained earlier) is to distort the waveform of the current flowing through it. Thus, if a sinusoidal voltage is applied the current flowing will be peaked, its form factor becoming greater than 1.11. This means that the actual rms value of current flowing will be greater than that indicated by the instrument i.e. the instrument reads low. The effect of series resistance is to "swamp" the variable resistance of the rectifying element. Thus greater the series resistance the lesser the error on this account. Since the series resistance has a small value in low range voltmeters and also the rectifier resistance changes considerably over low voltage limits (See Fig. 8'81), the error on this account is appreciable in low range voltmeters.

In practice, the departure from uniformity is inappreciable for instrument ranges exceeding 50 V, when the series resistance has a high value, as the change in rectifier resistance is only a small percentage of change in total resistance. The change in rectifier resistance may lead to difficulties in designing multi-range rectifier instruments incorporating low voltage ranges say 5 V, and therefore, some manufacturers supply a separate low voltage scale.

Effect of Temperature Changes

One of the major drawbacks of rectifier instruments is the errors caused by variation of the resistance of rectifying element with temperature. The compensation for this is carried out by making a part of the series resistor of copper, which has a positive resistance co-efficient and since the rectifier element has a negative resistance temperature co-efficient, the two effects can be made to neutralize each other. In case large temperature variations are expected the meter may be enclosed in a temperature controlled box.

Effect of Rectifier Capacitance

Rectifiers have the property of an imperfect capacitor, which bypasses high frequency currents. Thus the meters show a decreased reading which may be as large as 0.5 per cent per kHz rise in frequency. By decreasing the size of discs and other refinements this error may be decreased to less than 1 per cent per 100 kHz.

Decrease in Sensitivity. The sensitivity of meters decreases by using rectifier elements. This is best explained by the following example :

Example 8'46. An experimental voltmeter uses the bridge rectifier circuit where the PMMC movement has an internal resistance of 250 Ω and requires a d.c. current of 1 mA for full scale deflection. The diodes each have a forward resistance of 50 Ω and infinite resistance in the reverse direction. Calculate (a) the value of the series resistance R_s required for meter deflection when 25 V rms (sinusoidal) is applied to the meter terminal, (b) the sensitivity of the d.c. voltmeter (without rectifying element) and of a c. voltmeter.

A resistance of 250 Ω is placed in parallel with the meter movement, (c) calculate the new value of R_s to give full scale deflection for an input voltage of 25 V rms, (d) calculate the sensitivity of the instrument.

$$\text{Solution : (a) For full scale rectification } V_{av} = \frac{2\sqrt{2}}{\pi} V_{rms} = \frac{2\sqrt{2}}{\pi} \times 25 = 22.5 \text{ V.}$$

$$\text{Resistance of total voltmeter circuit } R_t = \frac{22.5}{1 \times 10^{-3}} = 22500 \Omega.$$

$$\text{But, } R_t = R_s + R_m = 2R_s + R_m \quad \text{where } R_s = \text{forward resistance of each rectifier.}$$

$$\therefore R_s = R_t - 2R_s - R_m = 22500 - 2 \times 50 - 250 = 22150 \Omega.$$

(b) Current for full scale deflection = 1 mA,

Sensitivity of the voltmeter on d.c. $S = \frac{1}{1 \times 10^{-3}} = 1000 \Omega/V.$

Sensitivity of the voltmeter on a.c. $S = \frac{22500}{25} = 900 \Omega/V.$

(c) When a resistance of 250 Ω is placed with the meter movement it shunts the current. Since the resistance of the movement is also 250 Ω , a circuit current of 2 mA is required for production of full scale deflection.

$$R_o = \frac{22.5}{2 \times 10^{-3}} = 11250 \Omega.$$

But $R_o = R_s + 2R_o + \frac{R_m \times R_{sh}}{R_m + R_{sh}}$ i.e., $11250 = R_s + 2 \times 50 + \frac{250 \times 250}{250 + 250}$

\therefore Series resistance required $R_s = 11025 \Omega.$ Sensitivity of meter $S = \frac{11250}{25} = 450 \Omega/V.$

(d) Sensitivity of a.c. voltmeter $S = \frac{9000 \Omega}{10 V} = 900 \Omega/V.$

Thus with a full wave rectifier, the sensitivity of a rectifier voltmeter with a.c. is 90% of its sensitivity as a pure d.c. voltmeter.

8'83. Half Wave Rectifier Circuits. The rectifier may have a half wave circuit as shown in Fig. 8'81 where the current flows through the meter every other half cycle.

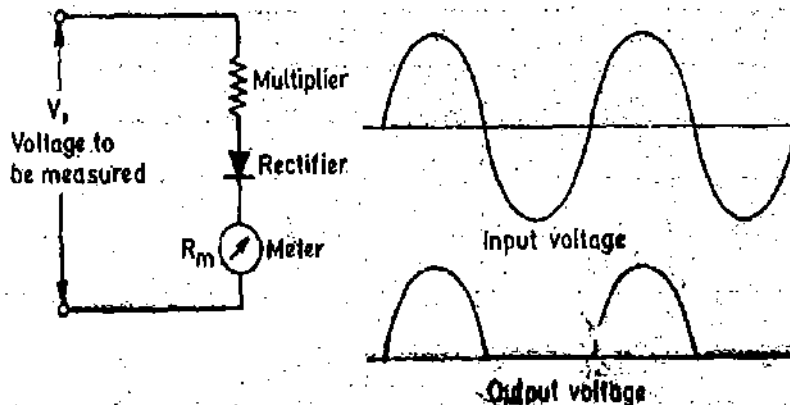

Fig. 8'83. Rectifier voltmeter with half wave rectification.

Average voltage $V_{av} = \frac{1}{\pi} V_m = \frac{\sqrt{2}}{\pi} V_{rms} = 0.45 V_{rms}$

Form factor $= \frac{V_{rms}}{V_{av}} = \frac{1}{0.45} = 2.22.$

In this case the sensitivity of the instrument is reduced to $\frac{1}{2}$ of its value for full wave rectification i.e. 45%.

Example 8'47. A rectifier type instrument uses a bridge rectifier and has its scale calibrated in terms of rms value of a sine wave. It indicates a current of 2.22 A when measuring a voltage having triangular waveshape. Estimate the peak and rms values of current. Also calculate the error.

Solution: The instrument is connected to a full wave rectifier. Thus it is calibrated by multiplying its markings by 1.11. Thus the meter indicates 1.11 times the average value of the rectified wave.

\therefore Average value of current $I_{av} = \frac{2.22}{1.11} = 2 A.$

For a triangular waveshape, the peak value of current is : $I_m = 2I_{av} = 2 \times 2 = 4 \text{ A.}$

$$\text{R.m.s. value of the current } I = \frac{I_m}{\sqrt{3}} = \frac{4}{\sqrt{3}} = 2.31 \text{ A.} \quad \therefore \text{Error} = \frac{2.22 - 2.31}{2.31} \times 100 = 3.9\% \text{ low.}$$

8.84. Multimeters. This arrangement is shown in Fig. 8.84. Two diodes (Rectifier elements) are used in this circuit, forming a full wave rectifier with the meter so connected that it receives only half of the rectified current. Rectifier D_1 conducts during the positive half cycle of the input waveform and causes the meter to deflect according to the average value of this half cycle. The meter move-

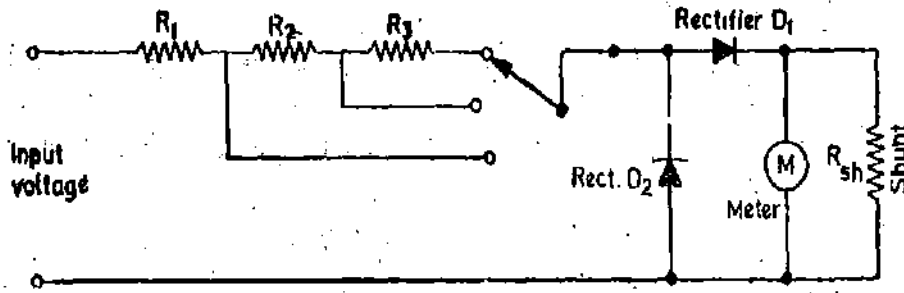

Fig. 8.84. Multivoltmeter.

ment is shunted by a resistance R_{sh} , in order to draw more current through rectifier D_1 and move its operating point into the linear portion of current-voltage characteristics. In the absence of rectifier D_2 , the negative half cycle of the input voltage would apply a reverse voltage across rectifier D_1 , causing a small leakage current in the reverse direction. The average value of the complete cycle would therefore be lower than it should be for half wave rectification. Rectifier D_2 deals with this problem. On the negative half cycle, D_2 conducts heavily and current through the measuring circuit which now is in the opposite direction, bypasses the meter.

The commercial multimeter often uses the same scale markings for both its d.c. and a.c. voltage ranges. Since the d.c. component of a sine wave for half wave rectification equals 0.45 times the rms value, a problem arises immediately. In order to obtain the same deflection on corresponding d.c. and a.c. voltage ranges, the multiplier for the a.c. range must be lowered proportionately. The circuit shown in Fig. 8.85 solves this problem and is illustrated by the following example.

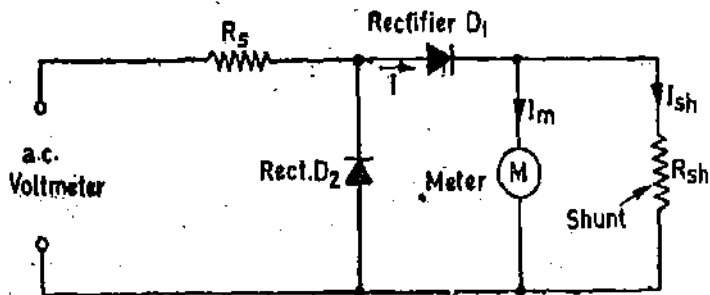

Fig. 8.85. Single range rectifier voltmeter.

Example 8.48. A meter has an internal resistance of 100Ω and requires 1 mA for full scale deflection. It is to be converted to a 10 V a.c. voltmeter using circuit of Fig. 8.85. The shunt resistor, placed across the meter has a value of 100Ω . Rectifiers D_1 and D_2 each have a forward resistance of 400Ω and is assumed to have infinite resistance in the reverse direction. Calculate (a) value of the multiplier R_s and (b) voltmeter sensitivity on the a.c. range.

Solution. In order that the meter draws its full scale current of 1 mA , the source must also deliver current through the shunt resistor. Since the meter resistance R_m and the shunt resistance R_{sh} are equal, the total current I supplied by the source must be $I = 2 \text{ mA}$.

Since it is a half wave rectifier, average value of d.c. emf is :

$$V_{av} = \frac{V_m}{\pi} = \frac{\sqrt{2}V_{rms}}{\pi} = 0.45 V_{rms} = 0.45 \times 10 = 4.5 \text{ V.}$$

Total resistance of the circuit $R_v = \frac{V_{ac}}{I} = \frac{4.5}{2 \times 10^{-3}} = 2250 \Omega$.

But $R_v = R_s + R_{f1} + \frac{R_m R_{sh}}{R_m + R_{sh}}$

where R_s = resistance of multiplier and R_{f1} = forward resistance of rectifier D_1

Since we are interested only in the resistance of the circuit during the half cycle that the meter receives current, and during this period rectifier D_2 presents infinite resistance and hence resistance of rectifier D_2 does not come into picture at all. Thus :

$$R_v = R_s + 400 + \frac{100 \times 100}{200} = R_s + 450$$

Therefore the resistance of multiplier $R_s = R_v - 450 = 2250 - 450 = 1800 \Omega$.

(b) The sensitivity of the voltmeter on 10 V a.c. range is:

$$S = \frac{R_v}{V_{rms}} = \frac{2250}{10} = 225 \Omega/V.$$

The same meter when used on d.c. has a sensitivity of 1000 Ω/V .

885. Simpson's Multimeter. We have dealt with d.c. circuitry of Simpson's multimeter in Art. 822. The circuit for measuring a.c. voltage is reproduced in Fig. 886. Resistances R_9 , R_{13} , R_7 and R_6 form a chain of multipliers for voltage ranges of 1000 V, 250 V, 50 V and 10 V respectively and their values have been indicated. On 2.5 V range resistor R_{23} has a resistance of R_s . Resistor R_{24} shunts the meter and therefore acts to improve the rectifier operation.

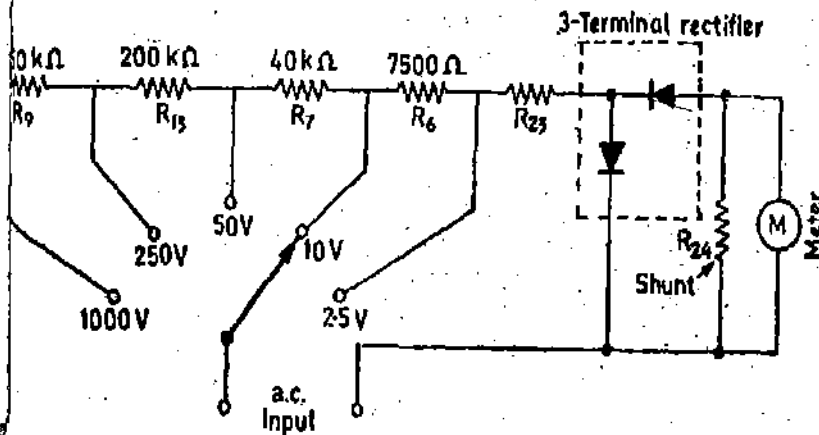

Fig. 886. Simpson's multimeter circuit for measuring a.c. voltages.

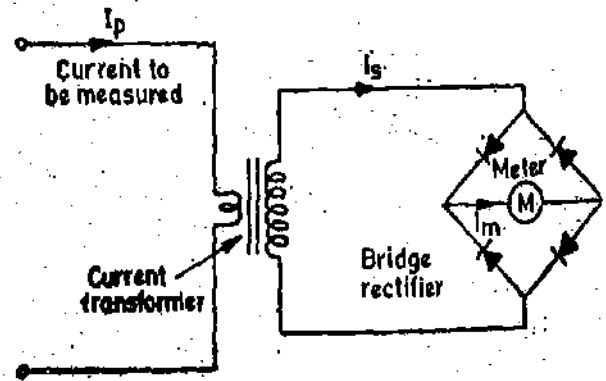

Fig. 887. Rectifier ammeter.

886. Rectifier Ammeters. A rectifier ammeter consists of a bridge-connected rectifier and a moving-coil instrument connected across the secondary of a current transformer (See Fig. 887). It is not possible to use a shunt (as in d.c. moving-coil instruments), as the proportion of the total current passing through the movement would vary widely with the total current, owing to the change of rectifier resistance with current. The resulting scale shape would depart so far from uniformity as to be practically useless. When a current transformer is used the secondary (instrument) current is proportional to the primary current (the current to be measured) whatever the value of instrument resistance, provided this resistance is not too high. The current transformer will differ in some particulars from those described in Chapter 9 e.g., its secondary will have a very large number of turns suitable for currents of the order of 1 mA. As the burden is so small, the transformer can be made very small in size and will be quite cheap; its frequency characteristics may also be made very good. The current range is 0–15 mA.

The effects of temperature coefficient, capacitance, and form factor may be considered along the lines indicated for the case of voltmeters.

8'87. Advantages of Rectifier Instruments. The chief advantages of rectifier instruments may be summarized as

(i) The frequency range extends from about 20 Hz to high audio frequencies ;

With the introduction of germanium and silicon rectifiers, rectifier instruments may be built in half wave configuration with a sensitive PMMC instrument at frequencies in the region of 3000 MHz.

(ii) These instruments have a much lower operating current for voltmeters (or higher value of ohm per volt) than other a.c. instruments, with the exception of electrostatic and valve voltmeters ;

(iii) They have a practically uniform scale for most ranges.

The chief errors and limitations have been dealt with in the general description of rectifier instruments given earlier in Art. 8'79.

Example 8'49. A sinusoidal alternating voltage of amplitude 100 V is applied across a circuit containing a rectifying device which entirely prevents current from flowing in one direction and offers a noninductive resistance of 10 Ω to the flow of current in the other direction. Find the reading on (a) a hot wire, (b) a moving coil ammeter in the circuit.

Solution. Maximum value of voltage applied $V_m = 100$ V

Instantaneous value of voltage $v = V_m \sin \theta = 100 \sin \theta$.

Instantaneous value of current in the forward direction (for a period $0 - \pi$)

$$i_f = \frac{v}{\text{resistance in the forward direction}} = \frac{100 \sin \theta}{10} = 10 \sin \theta.$$

Instantaneous value of current in the reverse direction (for a period π to 2π)

$$i_r = \frac{v}{\text{resistance in backward direction}} = \frac{e}{\infty} = 0$$

$$\text{R.M.S. value of current} = \sqrt{\frac{1}{2\pi} \left[\int_0^{\pi} i_f^2 d\theta + \int_{\pi}^{2\pi} i_r^2 d\theta \right]} = \sqrt{\frac{1}{2\pi} \int_0^{\pi} (10)^2 \sin^2 \theta d\theta} = 5 \text{ A}$$

$$\text{Average value of current } I_{av} = \int_0^{\pi} i_f d\theta + \int_{\pi}^{2\pi} i_r d\theta = \frac{1}{2\pi} \int_0^{\pi} 10 \sin \theta d\theta = 3.185 \text{ A.}$$

A hot wire ammeter reads rms value of current while a moving coil ammeter reads average value.

\therefore Reading of hot wire ammeter = 5 A.

Reading of moving coil ammeter = 3.185 A.

Example 8'50. A resistance of 50 Ω is connected in series with a rectifying device, a moving coil ammeter and a hot wire ammeter. The circuit is then connected across a sinusoidal a.c. supply of 100 V. The resistance of rectifying device is 50 Ω in one direction, and 250 Ω in the opposite direction. Calculate :

- (a) the readings on two ammeters, (b) power supplied from mains,
(c) power dissipated in the rectifying device.

Solution. R.M.S. value of voltage supplied $V_{rms} = 100$ V.

Maximum value of voltage $V_m = \sqrt{2} \times 100$ V.

Instantaneous value of voltage $v = \sqrt{2} \times 100 \sin \theta$.

Resistance in the forward direction $R_f = 50 + 50 = 100 \Omega$.

Resistance in the reverse direction $R_r = 250 + 50 = 300 \Omega$.

Instantaneous value of current in the forward direction

$$i_f = \frac{v}{R_f} = \frac{\sqrt{2} \times 100}{100} \sin \theta = \sqrt{2} \sin \theta.$$

Instantaneous value of current in the reverse direction

$$i_r = \frac{v}{R_r} = \frac{\sqrt{2} \times 100}{300} \sin \theta = \frac{\sqrt{2}}{3} \sin \theta$$

$$\text{R.M.S. value of current } I_{rms} = \sqrt{\frac{1}{2\pi} \left[\int_0^\pi (\sqrt{2} \sin \theta)^2 d\theta + \int_\pi^{2\pi} \left(\frac{\sqrt{2}}{3} \sin \theta \right)^2 d\theta \right]} = 0.745 \text{ A}$$

$$\text{Average value of current } I_{av} = \frac{1}{2\pi} \left[\int_0^\pi \sqrt{2} \sin \theta d\theta + \int_\pi^{2\pi} \frac{\sqrt{2}}{3} \sin \theta d\theta \right] = 0.3 \text{ A}$$

\therefore Reading of hot wire ammeter = 0.745 A. Reading of moving coil ammeter = 0.3 A.

Power taken from the mains

= power supplied in the forward half cycle + power supplied in the backward half cycle

$$= \frac{1}{2} \left(\frac{V^2}{R_f} + \frac{V^2}{R_r} \right) = \frac{1}{2} \left[\frac{(100)^2}{100} + \frac{(100)^2}{300} \right] = 66.7 \text{ W.}$$

Power consumed in 50 ohm resistor = $I^2 R = (0.745)^2 \times 50 = 27.7 \text{ W.}$

Power dissipated in rectifier = total power supplied - power consumed in resistor
 = 66.7 - 27.7 = 39 W.

Example 8.51. A current of $0.5 + 0.3 \sin \omega t - 0.2 \sin 2\omega t$ is passed through the circuit shown in Fig. 8.88. Determine the reading of each instrument if $\omega = 10^6$ rad/s.

Solution: The moving-coil reads average value of current while hot wire reads rms value of current. The electrostatic voltmeters do not take any current for their operation and they read the rms value of voltage.

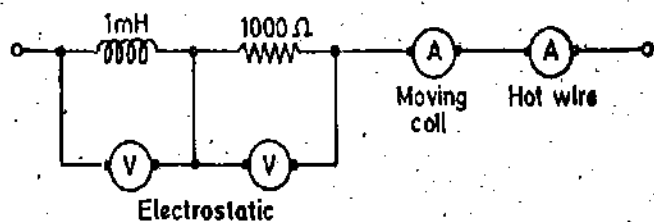

Fig. 8.88

Let i be the instantaneous value of current

$$i = I_0 + I_{1m} \sin \omega t + I_{2m} \sin 2\omega t = 0.5 + 0.3 \sin \omega t - 0.2 \sin 2\omega t.$$

Average value of a sinusoidal quantity over a full number of cycles or over a time very much greater than the time period of a cycle is equal to zero.

$$\therefore I_{av} = i = 0.5 \text{ A.}$$

Hence reading of moving-coil instrument = 0.5 A.

$$I_{rms} = \sqrt{I_0^2 + \left(\frac{I_{1m}}{\sqrt{2}} \right)^2 + \left(\frac{I_{2m}}{\sqrt{2}} \right)^2} = \sqrt{(0.5)^2 + \frac{0.09}{2} + \frac{0.04}{2}} = 0.561 \text{ A.}$$

Hence reading of Hot-wire instrument = 0.561 A.

Reading of Electrostatic voltmeter across 1000Ω resistance $V_R = 0.561 \times 1000 = 561 \text{ V}$.
 Instantaneous value of voltage across 1 mH inductor.

$$v_L = L \frac{di}{dt} = 1 \times 10^{-3} \frac{d}{dt} (0.5 + 0.3 \sin \omega t - 0.2 \sin 2\omega t)$$

$$= 1 \times 10^{-3} \omega (0.3 \cos \omega t - 0.4 \cos 2\omega t) = 300 \cos \omega t - 400 \cos 2\omega t \quad (\because \omega = 10^3)$$

Hence reading of electrostatic voltmeter across 1 mH inductor

$$V_L = \sqrt{\left(\frac{300}{\sqrt{2}}\right)^2 + \left(\frac{400}{\sqrt{2}}\right)^2} = 354 \text{ V.}$$

UNSOLVED PROBLEMS

1. A moving coil instrument has the following data : number of turns = 100, width of coil = 20 mm, depth of coil = 30 mm, flux density in the gap = 0.1 Wb/m^2 . Calculate the deflecting torque when carrying a current of 10 mA. Also calculate the deflection if the control spring constant is $2 \times 10^{-6} \text{ Nm/degree}$. [Ans. $60 \times 10^{-6} \text{ Nm}$, 30°]
2. The following data refers to a moving coil voltmeter.
Resistance, 10,000 ohm ; dimensions of coil 30 mm \times 30 mm ; number of turns on coil, 100 ; flux density in gap, 0.08 Wb/m^2 ; spring constant, $3 \times 10^{-6} \text{ N-m per degree}$. Find the deflection produced by a voltage of 200 V. [Ans. 48°]
3. A moving coil milli-voltmeter has a resistance of 200Ω and the full scale deflection is reached when a potential difference of 100 mV is applied across the terminals. The moving coil has effective dimensions of 30 mm \times 25 mm and is wound with 100 turns. The flux density in the gap is 0.2 Wb/m^2 . Determine the control constant of the spring if the final deflection is 100° and a suitable diameter of copper wire for the coil winding if 20 percent of the total instrument resistance is due to the coil winding. Resistivity of copper is $1.7 \times 10^{-8} \Omega \text{ m}$. [Ans. $7.5 \times 10^{-6} \text{ N-m/degree}$; 0.077 mm]
4. The coil of a measuring instrument has a resistance of 1Ω , and the instrument has a full scale deflection of 250 V when a resistance of 4999Ω is connected in series with it. Find (a) the current range of the instrument when used as an ammeter with the coil connected across a shunt of $1/499 \Omega$, and (b) the value of the shunt resistance for the instrument to give a full-scale deflection of 50 A. [Ans. 25 A ; 0.001001Ω]
5. A moving-coil instrument has at normal temperature a resistance of 10Ω and a current of 45 milliamperes gives full scale deflection. If its resistance rises to 10.2Ω due to temperature change, calculate the reading when a current of 2000 A is measured by means of a 2000 A shunt of constant resistance. What is the percentage error ? [Ans. 44.12 mA, -1.95%]
6. The coil of a moving-coil voltmeter is 40 mm \times 30 mm wide and has 100 turns wound on it. The control spring exerts a torque of $0.25 \times 10^{-3} \text{ N-m}$ when the deflection is 10 divisions on the scale. If the flux density of the magnetic field in the air-gap is 1 Wb/m^2 , estimate the resistance that must be put in series with the coil to give 1 volt per division. Resistance of voltmeter is $10,000 \Omega$. [Ans. $14,000 \Omega$]
7. A direct voltage of 240 V is applied to a uniform 200Ω resistor *abc*. A 40Ω resistor is tapped across *ab*. Find the resistance of *ab* in order that 1 A flows in the 40Ω resistor. [Ans. 71.65Ω]
8. A moving coil instrument has a resistance of 5Ω between terminals and full scale deflection is obtained with a current of 15 mA. This instrument is to be used with a manganin shunt to measure 100 A at full scale. Calculate the error caused by a 10°C rise in temperature :
 (a) when the internal resistance of 5Ω is due to copper only,
 (b) when a 4Ω manganin swamping resistance is used in series with a copper coil of 1Ω resistance.
 The resistance temperature co-efficients of copper and manganin are $0.4\%/^\circ \text{C}$ and $0.015\%/^\circ \text{C}$ rise respectively. [Ans. 3.7% low ; 1% low]
9. Design a multi-range ammeter with ranges of 1 A, 5 A, 25 A and 125 A employing individual shunts in each case. A d'Arsonval movement with an internal resistance of 730Ω and a full scale current of 5 mA is available. [Ans. 3.67Ω , 0.73Ω , 0.146Ω , 0.0292Ω]
10. A basic d'Arsonval movement with a full scale reading of $50 \mu\text{A}$ and an internal resistance of 1800Ω is available. It is to be converted into a 0-1 V, 0-5 V, 0-25 V and 0-125 V multi-range voltmeter using individual multipliers for each range. Calculate the value of the individual multipliers. [Ans. $18.2 \text{ k}\Omega$, $97.5 \text{ k}\Omega$, $497 \text{ k}\Omega$, $2490 \text{ k}\Omega$]
11. The Simpson multimeter model 260 uses a basic d'Arsonval movement of $50 \mu\text{A}$ with an internal resistance of 2000Ω . The multi-voltmeter ranges of this instrument are 0-2.5 V, 0-10 V, 0-50 V, 0-250 V, 0-1000 V and 0-5000 V. The instrument utilizes the potential divider arrangement shown in Fig. 8.15. Calculate the resistance values of R_1 , R_2 , R_3 , R_4 , R_5 , and R_6 . [Ans. $48 \text{ k}\Omega$, $150 \text{ k}\Omega$, $800 \text{ k}\Omega$, $4 \text{ M}\Omega$, $15 \text{ M}\Omega$, $80 \text{ M}\Omega$]
12. Design a series type ohmmeter (as shown in Fig. 8.17). The basic movement requires a current of 0.5 mA for full scale deflection and has an internal resistance of 50Ω . The internal battery has a voltage of 3.0 V. The

desired value of half scale resistance is 3000 Ω. Calculate (a) the values resistances R_1 and R_2 , (b) the range of values of R_2 , if the battery voltage may vary from 2.7 V to 3.1 V. Use value of R_1 as calculated in (a).

[Ans. (a) $R_1=2975 \Omega$, 50 Ω, (b) 62.5–46.8 Ω]

13. A shunt type ohmmeter, with circuit as shown in Fig. 8.18 uses a basic meter with a full scale current of 2 mA and an internal resistance of 25 Ω. The battery has an emf of 1.5 V. Find (a) the value of resistance R_1 , (b) At what point (in percentage of full scale) will 100 Ω be marked on the scale? [Ans. (a) 725 Ω, (b) 80.5%]

14. The inductance of a certain moving iron ammeter is $(8+4\theta+16\theta^2)$ μH, where θ is the deflection in radian from the zero position. The control spring torque is 12×10^{-8} N-m/rad. Calculate the scale positions in radian for currents 1, 2, 3, 4 and 5 A and discuss the scale shape obtained. [Ans. 0.16, 0.571, 1.091, 1.6, 2.04 rad]

15. The inductance of a moving iron ammeter is given by :

$$L = (0.01 + K\theta)^2 \text{ mH}$$

where θ is the deflection from zero position. The angular deflections of the instrument corresponding to 1.5 and 2 A are respectively 90° and 120°. Find the value of K. [Ans. 0.0464×10^{-3}]

16. The relationship between inductance of a moving iron ammeter, the current and the position of the pointer is as follows :

Reading (A)	0.8	1.0	1.2	1.4	1.6	1.8	2.0
Deflection (degree)	16.5	26	36	46.5	57	70	86
Inductance (μH)	527.8	573.9	575	576.2	577.3	578.35	579.43

Calculate the deflecting torque when the current is 1.5 A and 2.1 A. [Ans. 6.45×10^{-8} Nm, 5.73×10^{-8} Nm]

17. The control spring of moving iron ammeter exerts a torque of 0.5×10^{-6} N-m/degree when the deflection is 52°. The inductance of the coil varies with pointer deflection according to :

Deflection (degree)	20	40	60	80
Inductance (μH)	659	702	752	792

Determine the current passing through the meter. [Ans. 0.63 A]

18. The copper coil of a 150 V moving iron voltmeter has a resistance of 400 ohm at 15°C and an inductance of 0.75 H. The current for full scale deflection is 0.05 A.

The temperature coefficients of resistance for copper and eureka at 15°C are 0.004 and 0.00001 Ω/Ω-°C respectively. Calculate :

(a) the percentage increase of resistance of this instrument per degree rise in temperature, (b) the indication when 150 V at 100 Hz is applied, the instrument having been previously calibrated on direct current. [Ans. 0.0542%, 148.17 V]

19. A soft-iron voltmeter for a maximum reading of 120 V has an inductance of 0.6 H and a total resistance of 2,400 Ω. It is calibrated to read correctly on a 60 Hz circuit. What series resistance would be necessary to increase its range to 600 V? Draw up suitable workshop instructions for making up the resistance. [Ans. 9,660 Ω]

20. An alternating current voltmeter, with a maximum scale reading of 50 V, has an inductance of 0.09 H and a total resistance of 500 Ω. The coil is wound with copper wire having a resistance of 50 Ω and the remainder of the voltmeter circuit consists of a non-inductive resistance in series with the coil. Find the capacitance that should be placed across the non-inductive resistor to make the instrument read correctly both on d.c. as well as a.c. [Ans. 0.182 μF]

21. The following measurements were made on a voltmeter of the dynamometer type, having a range of 60 V and a resistance of 780 Ω.

Applied voltage (V)	30	40	50	60
Deflection (degree)	14	24	37	54
Inductance (mH)	74.8	78.5	82.8	88.6

Calculate the deflecting torque when the applied voltage is 45 V. [Ans. 64.6×10^{-8} N-m]

22. The following measurements were made on a 50 V dynamometer type voltmeter having a resistance of 750 Ω.

Deflection (degrees)	10	20	30	50	70	80	90
Mutual Inductance (μH)	67.2	72	77	86	94.4	98	100

A torque of 0.5×10^{-6} Nm is required to give full scale deflection of 90°. Calculate the voltage at half full scale reading. [Ans. 23.3 V]

23. A thermocouple instrument reads 10 ampere at full scale. Determine the current when the meter reads one third of full scale. [Ans. 5.78 A]

24. The spring constant of a 3000 volt electrostatic voltmeter is 7.06×10^{-4} Nm/rad. The full scale deflection of the instrument is 80° . Assuming the rate of change of capacitance with angular deflection to be constant over the operating range, calculate the total change of capacitance from zero to full scale. [Ans. 3.06 pF]

A deflecting electrostatic voltmeter gives full scale deflection of 40° with 9 V applied to its terminals. Its capacitance is 10 pF at zero deflection and 30 pF at 30° , and varies uniformly with deflection. The moment of inertia of moving vanes is 0.02×10^{-8} kg-m². Calculate the undamped period of instrument. [Ans. 18.9 second]

26. There are 7 cells in a kelvin multicellular voltmeter. The needle is in the form of two sectors of a circle of radius 50 mm. The distance between the fixed quadrants is 4 mm and the needle is hung midway between them. Application of a voltage of 1000 V gives a deflection of 90° . Calculate the spring constant. [Ans. 49.3×10^{-6} Nm/rad]

27. The plates of an absolute electrometer, which are 250 mm in diameter and 20 mm apart are charged to a potential difference of 10 kV, calculate the force of attraction between the plates and the charge on each. [Ans. 0.064 N, 0.22 μ C]

28. The movable vane of a quadrant electrometer turns through 40 scale divisions when it is electrostatically connected to a potential of 100 V. When it is used heterostatically with the quadrants connected to a small voltage e and the needle to a 400 V supply, the deflection is 15 scale divisions. Determine the voltage e . [Ans. 3.7 V]

29. The capacity of an electrostatic voltmeter reading from 0 to 2000 V increases from 80 to 90 pF as the pointer moves from zero to full scale deflection. Calculate the value of external capacitor used to increase its range to 20 kV. If the capacitor is adjusted to make the full scale reading correct, what will be the error at half-scale reading? [Ans. 10 pF, 5.27% high]

30. A single element rectifying device is connected in series with a moving coil ammeter and a thermal ammeter and it is found that the circuit has a resistance of 100 Ω in one direction and infinity in the other direction. If a sinusoidal emf of 10 V rms is applied to this circuit what will be the reading of each instrument and what will be the power taken from the supply? [Ans. PMCC 0.045 A, Thermal 0.0707 A, 0.5 W.]

31. In a bridge connected rectifier voltmeter each rectifier has a resistance of 20 Ω in the forward direction and infinity in the reverse direction. The moving coil indicator has resistance of 10 Ω and gives full scale deflection for 10 mA. Determine the series resistance necessary if the instrument is to read the correct rms value at $\frac{1}{2}$ full scale when connected to a source of voltage:

$$v_1 = 100\sqrt{2} \sin \omega t.$$

If this instrument, and an accurate electrodynamic voltmeter are connected across a voltage

$$v_2 = 100\sqrt{2} \sin \omega t + 10\sqrt{2} \sin 3\omega t, \text{ determine reading of each instrument.}$$

[Ans. 17970 Ω ; Rectifier 103.2 V, Electrodynamic 100.5 V]

32. A rectifier voltmeter uses a full wave rectifier. The meter has an internal resistance of 50 Ω and requires a current of 1 mA for full scale deflection. The rectifiers each have zero forward resistance and infinite reverse resistance.

Calculate, (a) the multiplier resistance required for full scale meter deflection with 10 V a.c., (b) sensitivity of d.c. voltmeter, (c) the sensitivity in Ω /V with a.c. [Ans. (a) 89.0 Ω , (b) 1000 Ω /V, (c) 900 Ω /V]

33. A commercial meter of Fig. 8.83 uses a 1 mA basic meter with an internal resistance of 100 Ω . The shunting resistance across the meter is 200 Ω . Diodes D_1 and D_2 each have a forward resistance of 200 Ω and infinite reverse resistance. Calculate the value of series multiplier so that the meter is converted to a 10 V a.c. voltmeter. Determine the sensitivity as an a.c. voltmeter. [Ans. 2733.3 Ω ; 300 Ω /V]

34. A direct current of about 2 A is to be measured accurately. If the following 3 ammeters are available, which would you prefer to use for this purpose? Give clear reasons for your choice.

(i) Permanent magnet moving coil type with 0–5 A range and 0.5 per cent accuracy at full scale.

(ii) Permanent magnet moving coil with 0–3 A range and 1 per cent accuracy at full scale.

(iii) Moving iron type with 0–2.5 A range per cent at full scale.

35. What will be the reading when a voltage

$$e = 200 \sin \omega t + 40 \sin (3\omega t + 30^\circ) + 30 \cos (5\omega t + 21.5^\circ) \text{ volt}$$

is applied to an electrodynamic voltmeter.

[Ans. 145.8 V]

36. An electrodynamic ammeter and a permanent magnet moving coil ammeter are connected in series with a 100 Ω resistor and a rectifier having a forward resistance 50 Ω and backward resistance of 500 Ω . A voltage having triangular waveform and a frequency of 50 Hz and rms value of 100 V is applied to the circuit. Calculate (a) the reading of each ammeter, and (b) the effective power factor of the circuit.

[Ans. (a) dynamometer, 0.486 A; PMCC, 0.361 A (b) 0.856]

37. A millivoltmeter has two scales reading 0–20 mV and 0–100 mV, the resistance of two ranges being 400 Ω and 2000 Ω respectively. When used in conjunction with a thermopile, a certain reading changed from 19.5 to 23.4 mV when the range was altered from the lower to the higher scale. Calculate (a) the resistance of the thermopile, (b) its emf, and (c) the correction multiplier. [Ans. (a) 105.4 Ω ; (b) 24.6 mV; (c) 1.26, 1.05]

Instrument Transformers

9'1. **Introduction.** Transformers are used in a.c. systems for the measurement of current, voltage, power and energy. They are also used in connection with measurement of power factor, frequency and for indication of synchronism.

Transformers find a wide application in protection circuits of power systems for the operation of over current, under voltage and various other types of relays.

In all the above applications, the transformer is put for measurement purposes, the actual measurements being done by measuring instruments. Transformers used in conjunction with measuring instruments for measurement purposes are called "Instrument Transformers". The transformer used for measurement of current is called a "Current Transformer" or simply "C.T." Transformers for voltage measurement are called "Voltage Transformers" or "Potential Transformers" or simply "P.T." for short.

9'2. **Use of Instrument Transformers.** The extension of instrument range, so that current, voltage, power and energy can be measured with instruments or meters of moderate size is of very great importance in commercial metering. Here currents and voltages handled are very large and, therefore, direct measurements are not possible as these currents and voltages are far too large for any meter of reasonable size and cost. The solution lies in stepping down these currents and voltages with instrument transformers so that they could be metered with instruments of moderate size.

Fig. 9'1 shows current being measured by a C.T. The primary winding is so connected that the current being measured passes through it and the secondary is connected to an ammeter. The "C.T." steps down the current to the level of ammeter.

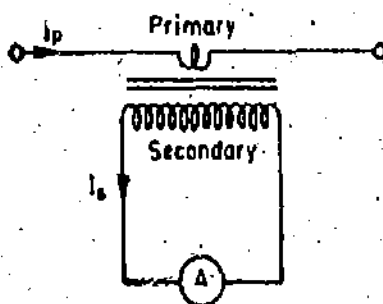

Fig. 9'1. Current transformer.

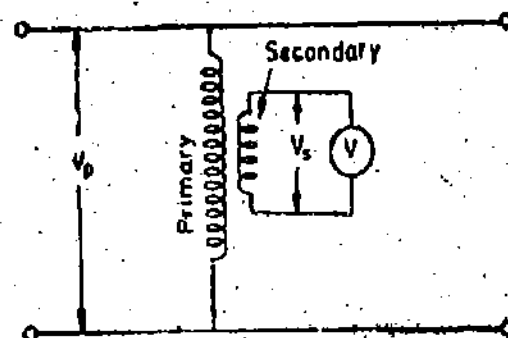

Fig. 9.2. Potential transformer.

Fig. 9'2 shows voltage measurement with P.T. The primary is connected to the voltage being measured and the secondary, to voltmeter. The 'P.T.' steps down the voltage to the level of voltmeter.

It might appear that extension of range could be conveniently done by the use of shunts for currents, and multipliers for voltage measurements, as is done in d.c. measurements. But this method is suitable only for small values of current and voltage. There are certain disadvantages with the use of shunts and multipliers.

Disadvantages of Shunts. (i) It is difficult to achieve accuracy with a shunt on a.c., since division of current between a meter and shunt depends upon the reactance and resistance of two paths. For proper measurements, time constants of meter and shunt should be the same. Therefore, a separate shunt would be needed for each instrument.

Also since measurements are made over a wide frequency range it becomes difficult to obtain good accuracy with shunts.

(ii) The shunt method is limited to capacities of a few hundred ampere at most, since the power consumed by shunts at large currents would be considerable large.

(iii) The problem of insulation of instrument and shunt is quite difficult to solve if measurements are done at high voltages of several hundred or thousand volt above ground.

(iv) The measuring circuit is not isolated electrically from the power circuit.

Disadvantages of Multipliers. Multipliers for voltage measurements do not present any serious difficulties below 1000 V. But their use above this limit becomes impractical owing to the following reasons :

(i) The power consumed by multipliers becomes large as the voltage increases. A power dissipation of about 7.5 W is the upper limit for a self-contained instrument.

(ii) Care has to be exercised to keep leakage currents in high voltage multipliers down to negligible values. However, insulation of multipliers required to prevent leakage currents and the reduction of distributed capacitance to avoid shunt capacitance currents becomes very difficult above a few thousand volt. Special types of construction are needed to prevent the above effects. Hence the construction of multipliers for use at high voltages is very costly and complicated.

(iii) The measuring circuit is not electrically isolated from the power circuit.

Advantages of Instrument Transformers. The current and voltage transformers are extensively used for very precise measurements as well as for routine measurements as they have many advantages :

(i) When instruments are used in conjunction with instrument transformers, their readings do not depend upon their constants (R, L, C) as is the case with shunts and multipliers. The instrument transformers produce practically the same instrument reading regardless of the constants of the instrument or, in fact, the number of instruments connected in the circuit.

(ii) Current transformers have been standardized at 5 A secondary current and the voltage transformers at from 100 to 120 V secondary voltage. These are very moderate ratings and the instruments for measurements are rated near these. Thus a 5 A ammeter may be used to measure 1000 A with the help of a 1000/5 A ratio current transformer or a 110 V voltmeter may be used to measure a voltage of 66 kV with the help of a 66,000/110 V potential transformer. Therefore, very cheap moderate rating instruments may be used to measure large currents and high voltages.

(iii) With the standardization of C.T. and P.T. secondary ratings, it is possible to standardize instruments around these ratings and, therefore, there is great reduction in the costs of transformers and instruments. Replacement is also very easy.

(iv) The measuring circuit is isolated from the power circuit. The fact that the meters in the secondary circuit of an instrument transformer are isolated electrically from the primary side is of very great importance in high voltage systems. Large alternators usually operate at voltages between 11 kV to 20 kV while transmission voltages as high as 750 kV are being used. Therefore, in all electrical systems it is necessary to have a measure of currents and voltages, both for metering purposes and for the operation of protective relays and other equipment. It is impossible to bring the high voltage lines directly to the switchboard to be connected to instruments as even for voltages upto a few thousand volt it would be difficult to insulate the equipment to provide safety for the operating person.

The situation is completely changed with the use of instrument transformers, as only the leads from the secondaries of the instruments transformers are brought to the switchboard for connection to

the metering equipment. The voltages between these leads and between leads and ground are very low and hence the operators can work safely.

In fact instrument transformers are so important for insulating and range extension purposes that it is difficult to imagine the operation on an a.c. system without them.

Summarizing the above, we can say that the use of instrument transformers for range extension has the following advantages :

(1) Moderate size instruments are used for metering *i.e.*, 5 A for current and 100 to 120 V for voltage measurements.

(2) Instruments and meters can be standardized so that there is a saving in overall costs. Replacement of damaged instruments is easy.

(3) Single range instruments can be used to cover a large current or voltage ranges, when used with suitable multi-range instrument transformers or with several single range instrument transformers.

(4) The metering circuit is isolated from the high voltage power circuits. Hence insulation is no problem and the safety is assured for the operators.

(5) There is low power consumption in metering circuit.

(6) Several instruments can be operated from a single instrument transformer.

9.3. Ratios. There are some definitions which must be given here.

Transformation Ratio. It is the ratio of the magnitude of the primary phasor to the secondary phasor.

$$\text{Transformation ratio } R = \frac{|\text{primary phasor}|}{|\text{secondary phasor}|} \quad \dots(9.1)$$

$$= \frac{\text{primary current}}{\text{secondary current}} \text{ for a C.T.} \quad \dots(9.2)$$

$$= \frac{\text{primary voltage}}{\text{secondary voltage}} \text{ for a P.T.} \quad \dots(9.3)$$

Nominal Ratio. It is the ratio of rated primary current (or voltage) to the rated secondary current (or voltage).

$$\text{Nominal ratio } K_n = \frac{\text{rated primary current}}{\text{rated secondary current}} \text{ for a C.T.} \quad \dots(9.4)$$

$$= \frac{\text{rated primary voltage}}{\text{rated secondary voltage}} \text{ for a P.T.} \quad \dots(9.5)$$

$$\text{Turns Ratio. Turns Ratio } n = \frac{\text{number of turns of secondary winding}}{\text{number of turns of primary winding}} \text{ for a C.T.} \quad \dots(9.6)$$

$$= \frac{\text{number of turns of primary winding}}{\text{number of turns of secondary winding}} \text{ for a P.T.} \quad \dots(9.7)$$

Ratio Correction Factor (RCF). The ratio correction factor of a transformer is the transformation ratio divided by nominal ratio.

$$\text{Transformation ratio} = \text{ratio correction factor} \times \text{nominal ratio} \quad \text{or } R = RCF \times K_n \quad \dots(9.8)$$

The ratio marked on the transformers is their nominal ratio.

9.4. Burden. It is convenient to express load across the secondary terminals as the output in volt-ampere at the rated secondary voltage. The rated burden is the volt-ampere loading which is permissible without errors exceeding the limits for the particular class of accuracy.

Total secondary burden

$$\begin{aligned} &= \frac{(\text{secondary induced voltage})^2}{(\text{impedance of secondary circuit including impedance of secondary winding})} \\ &= (\text{secondary current})^2 \times (\text{impedance of secondary circuit including secondary winding}) \end{aligned} \quad \dots (9.9)$$

$$\begin{aligned} \text{Secondary burden due to load} &= \frac{(\text{secondary terminal voltage})^2}{(\text{impedance of load on secondary winding})} \\ &= (\text{secondary current})^2 \times (\text{impedance of load on secondary winding}) \end{aligned} \quad \dots (9.10)$$

9.5. CURRENT TRANSFORMERS. The current transformer is used with its primary winding connected in series with line carrying the current to be measured and, therefore, the primary current is not determined by the load on the current transformer secondary. The primary consists of very few turns and, therefore, there is no appreciable voltage across it. The secondary of the current transformer has larger number of turns, the exact number being determined by the turns ratio. The ammeter, or wattmeter current coil, is connected directly across the secondary terminals. Thus a current transformer operates its secondary nearly under short circuit conditions. One of the terminals of the secondary winding is earthed so as to protect equipment and personnel in the vicinity in the event of an insulation breakdown in the current transformer. Fig. 9.3 shows a circuit for measurement of current and power with a current transformer.

9.6. Theory. Fig. 9.4 represents the equivalent circuit and Fig. 9.5 the phasor diagram of a current transformer. The diagrams are same as for any other transformer.

$$n = \text{turns ratio} = \frac{\text{number of secondary winding turns}}{\text{number of primary winding turns}}$$

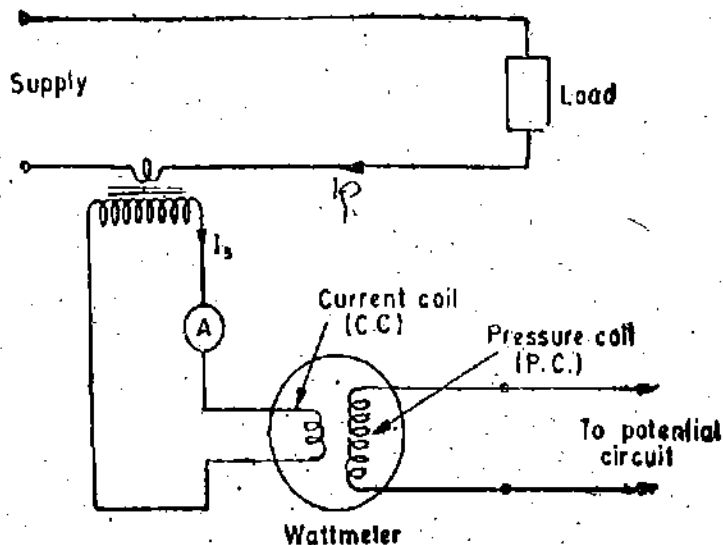

r_s = resistance of the secondary winding,
 x_s = reactance of the secondary winding,
 r_o = resistance of external burden i.e., resistance of meters current coils etc. including leads,
 x_o = reactance of external burden i.e., reactance of meters, current coils, etc. including leads,
 E_p = primary induced voltage,
 E_s = secondary induced voltage,

Fig. 9.3. Use of C.T. for current and power measurement.

N_p = number of primary winding turns, N_s = number of secondary winding turns,
 V_s = voltage at the secondary winding terminals, I_s = secondary winding current,
 I_p = primary winding current, θ = phase angle of transformer,
 Φ = working flux of the transformer,
 δ = angle between secondary induced voltage and secondary current,

$$\delta = \text{phase angle of total burden including impedance of secondary winding} = \tan^{-1} \left(\frac{x_s + x_o}{r_s + r_o} \right)$$

$$\Delta = \text{phase angle of secondary load circuit i.e., of external burden} = \tan^{-1} \frac{x_o}{r_o}$$

I_0 = exciting current,

I_m = magnetising component of exciting current, I_w = loss component of exciting current.

α = angle between exciting current I_0 and working flux Φ .

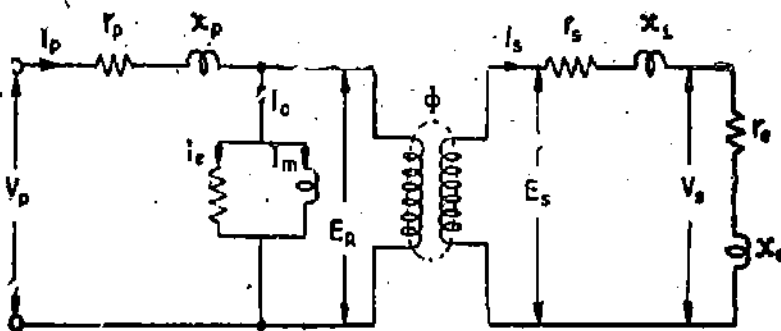

Fig. 9'4. Equivalent circuit of a C.T.

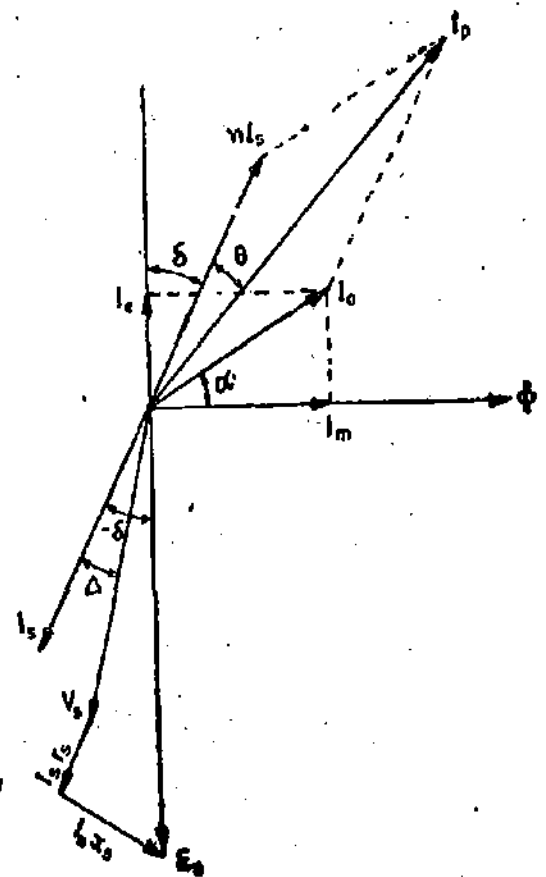

Fig. 9'5. Phasor diagram of a C.T.

Transformation Ratio. Consider a small section of the phasor diagram as shown in Fig. 9'6.

We have $\angle bac = 90^\circ - \delta - \alpha$, $ac = I_0$, $oa = nI_s$ and $oc = I_p$.

$\therefore bc = I_0 \sin(90^\circ - \delta - \alpha) = I_0 \cos(\delta + \alpha)$, $ab = I_0 \cos(90^\circ - \delta - \alpha) = I_0 \sin(\delta + \alpha)$.

Now $(oc)^2 = (oa + ab)^2 + (bc)^2$ or $I_p^2 = [nI_s + I_0 \sin(\delta + \alpha)]^2 + [I_0 \cos(\delta + \alpha)]^2$

$$= n^2 I_s^2 + I_0^2 \sin^2(\delta + \alpha) + 2nI_s I_0 \sin(\delta + \alpha) + I_0^2 \cos^2(\delta + \alpha)$$

$$= n^2 I_s^2 + 2nI_s I_0 \sin(\delta + \alpha) + I_0^2$$

$$\therefore I_p = [n^2 I_s^2 + 2nI_s I_0 \sin(\delta + \alpha) + I_0^2]^{1/2} \quad \dots(9'11)$$

Transformation ratio

$$R = \frac{I_p}{I_s} = \frac{[n^2 I_s^2 + 2nI_s I_0 \sin(\delta + \alpha) + I_0^2]^{1/2}}{I_s} \quad \dots(9'12)$$

Now in a well designed current transformer $I_0 \ll nI_s$. Usually I_0 is less than 1 per cent of I_p and I_p is, therefore, very nearly equal to nI_s .

\therefore Eqn. 9'12 can be written as

$$R \approx \frac{[n^2 I_s^2 + 2nI_s I_0 \sin(\delta + \alpha) + I_0^2 \sin^2(\delta + \alpha)]^{1/2}}{I_s}$$

$$\approx \frac{nI_s + I_0 \sin(\delta + \alpha)}{I_s} \approx n + \frac{I_0}{I_s} \sin(\delta + \alpha) \quad \dots(9'13)$$

Although only approximate, Eqn. 9'13 is sufficiently accurate for practically all purposes. The above theory is applicable to case when the secondary burden has a lagging power factor i.e., when the burden is inductive which is normally the case.

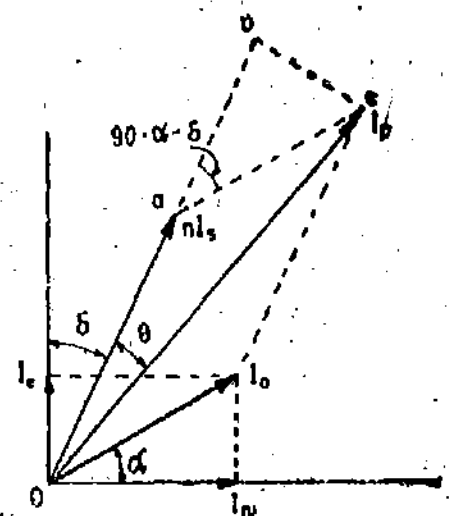

Fig. 9'6. A section of phasor diagram of a C.T.

Eqn. 9.13 can be further expanded as :

$$R \approx n + \frac{I_0}{I_s} (\sin \delta \cos \alpha + \cos \delta \sin \alpha) \approx n + \frac{I_m \sin \delta + I_e \cos \delta}{I_s} \quad \dots(9.14)$$

as

$$I_m = I_0 \cos \alpha \text{ and } I_e = I_0 \sin \alpha$$

Phase Angle. The angle by which the secondary current phasor, when reversed, differs in phase from the primary current, is known as the phase angle of the transformer.

This angle is taken to be +ve if the secondary current reversed leads the primary current. The angle is taken as -ve if secondary current reversed lags behind the primary current.

The angle between I_s reversed and I_p is θ . Therefore, the phase angle is θ .

$$\text{From the phasor diagram (Fig. 9.6) } \tan \theta = \frac{bc}{ob} = \frac{bc}{oa+ab} = \frac{I_0 \cos(\delta+\alpha)}{nI_s + I_0 \sin(\delta+\alpha)}$$

$$\text{As } \theta \text{ is very small, we can write } \theta = \frac{I_0 \cos(\delta+\alpha)}{nI_s + I_0 \sin(\delta+\alpha)} \text{ rad.} \quad \dots(9.15)$$

Now I_0 is very small as compared to nI_s and therefore, we can neglect the term $I_0 \sin(\delta+\alpha)$

$$\therefore \theta \approx \frac{I_0 \cos(\delta+\alpha)}{nI_s} \text{ rad.} \quad \dots(9.16)$$

$$\approx \frac{I_0 \cos \delta \cos \alpha - I_0 \sin \delta \sin \alpha}{nI_s} \approx \frac{I_m \cos \delta - I_e \sin \delta}{nI_s} \text{ rad.} \quad \dots(9.17)$$

$$\approx \frac{180}{\pi} \left(\frac{I_m \cos \delta - I_e \sin \delta}{nI_s} \right) \text{ degree} \quad \dots(9.18)$$

9.7. Errors. It is clear from Eqn. 9.14 that the value of transformation ratio (actual ratio) is not equal to the turns ratio. Also the value is not constant, but depends upon the magnetizing and loss components of the exciting current, the secondary load current and its power factor. This means that the secondary current is not a constant fraction of the primary current but depends upon the factors listed above. This introduces considerable errors into current measurements.

In power measurements, it is necessary that the phase of secondary current shall be displaced by exactly 180° from that of the primary current. It is seen that the phase difference is different from 180° by an angle θ . Thus in power measurements, owing to use of C.T. two types of errors are introduced; one due to actual transformation ratio being different from the turns ratio, and the other due to secondary current not being 180° out of phase with the primary current.

Ratio error. Ratio Error is defined as :

$$\text{Percentage ratio error} = \frac{\text{nominal ratio} - \text{actual ratio}}{\text{actual ratio}} \times 100$$

$$= \frac{K_n - R}{R} \times 100 \quad \dots(9.19)$$

$$\text{Phase angle error. Phase angle } \theta = \frac{180}{\pi} \left[\frac{I_m \cos \delta - I_e \sin \delta}{nI_s} \right] \text{ degree}$$

Approximate formulae for errors. The usual instrument burden is largely resistive with some inductance and therefore, δ is positive and is generally small.

Hence $\sin \delta \approx 0$ and $\cos \delta \approx 1$. Therefore, we can write Eqns. 9.14 and 9.18 as

$$R \approx n + \frac{I_e}{I_s} \quad \dots(9.20)$$

and
$$\theta \approx \frac{180}{\pi} \left[\frac{I_m}{nI_p} \right] \text{ degree} \quad \dots(9'21)$$

But $I_p \approx nI_s$ and therefore, Eqns. 9'20 and 9'21 can be rewritten as :

$$R \approx n + \frac{nI_s}{I_p} = n \left(1 + \frac{I_s}{I_p} \right) \quad \dots(9'22)$$

and
$$\theta = \frac{180}{\pi} \frac{I_m}{I_p} \text{ degree} \quad \dots(9'23)$$

9'8. Characteristics of Current Transformers

1. Effect of P.F. of Secondary Burden on Errors

Ratio Error. It is observed that for all inductive burdens the secondary current, I_s , lags behind the secondary induced voltage, E_s , so that δ is positive. Under these conditions the actual transformation ratio is always greater than the turns ratio (See Eqn. 9'13). For burdens which are sufficiently capacitive I_s leads E_s and so δ is negative. Under these conditions, the actual transformation ratio decreases becoming less than the turns ratio for values of δ approaching -90° .

Phase Angle. Examining Eqn. 9'16, we find that for inductive burdens, phase angle θ is positive for small values of δ (high secondary p.f.) but becomes negative as the secondary burden becomes more inductive and δ approaches 90° . For negative values of δ (sufficiently capacitive burdens) θ is always positive.

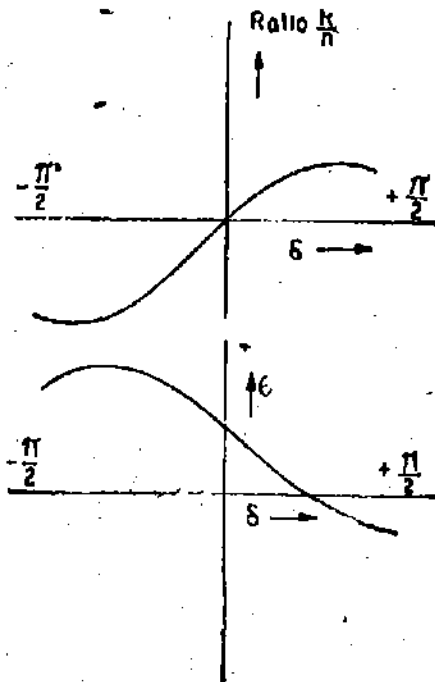

Fig. 9'7. Variation of transformation ratio and phase angle with p.f. of secondary winding circuit.

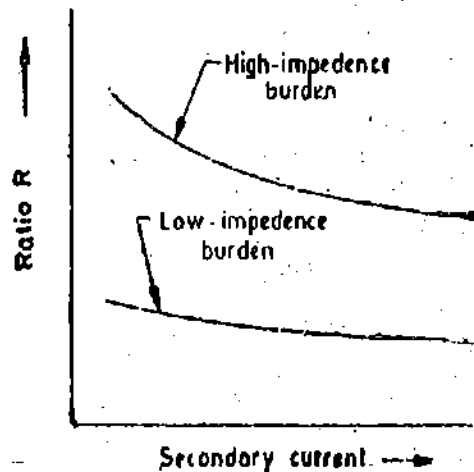

Fig. 9'8. Variation of ratio R with secondary current.

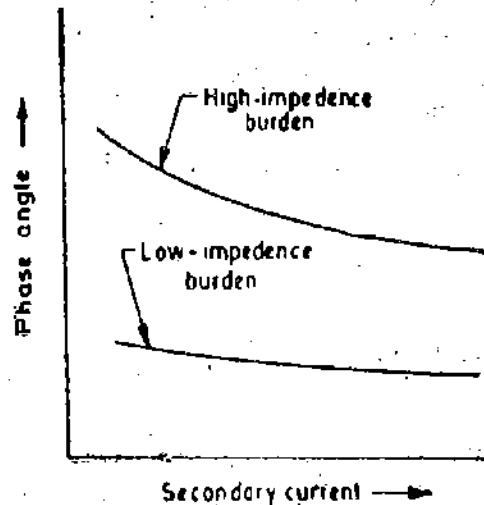

Fig. 9'9. Variation of phase angle with secondary current.

The variation of transformation ratio R and phase angle θ with δ is shown in Fig. 9'7. These conclusions are based upon the assumption that the magnitude of secondary impedance remains constant.

2. Effect of Change of Primary Current. If the primary current changes the secondary current changes proportionately. At low values of current I_p (or I_s) exciting current I_m and loss component I_e are a greater proportion of I_p and, therefore, the errors are greater. As the current I_p increases, there is an increase in I_e and there is a decrease in ratio error and phase angle. It is clear from Eqns. 9'22 and 9'23. The variation of ratio error and phase angle with secondary current is shown in Figs. 9'8 and 9'9.

3. Effect of Change in Secondary Burden. An increase in secondary burden impedance means an increase in volt ampere rating. This necessitates an increase in the secondary induced voltage which can be generated by an increased flux and flux density. Therefore both magnetizing component I_m and I_e are increased. Thus it is expected that errors will increase with increase in secondary burden. In general, a greater burden impedance not only increases the transformation ratio, but also shifts the phase angle between primary and secondary to more positive value as shown in Figs. 9'8 and 9'9.

4. Effect of Change of Frequency. The effect of increase in frequency will result in proportionate decrease in flux density. Thus, in general, the effect of increase in frequency is similar to that produced by decrease in impedance of secondary burden.

A current transformer is seldom used at a frequency which is very different from the one or which it is designed and, therefore, consideration of this effect is not very important.

9'9. Causes of Errors. In an ideal transformer, the actual transformation ratio would be equal to the turns ratio and the phase angle would be zero. However, as a result of physical limitations inherent in electric and magnetic circuits of the transformer, there are departures from this ideal and consequently there are errors caused. The reasons are :

(i) There is some exciting mmf required by the primary winding to produce flux and, therefore, the transformer draws a magnetizing current I_m .

(ii) The transformer input must have a component which supplies the core losses (eddy current and hysteresis losses) and I^2R losses of transformer windings.

Therefore, loss component I_e is required to feed the losses associated with the flux and also the associated copper loss in winding due to flow of I_e .

(iii) The flux density in the core is not a linear function of the magnetizing force, i.e., the transformer core becomes saturated.

(iv) There is always a magnetic leakage and consequently the primary flux linkages are not equal to the secondary flux linkages.

9'10. Reduction of Errors. It is clear from Eqn. 9'22 and 9'23 that for usual types of burdens, the difference between actual transformation ratio and the turns ratio depends largely on the loss component I_e and the transformer phase angle depends largely on magnetizing current I_m . It is obvious that if the ratio has to be close to the turns ratio and the phase angle is to be small, I_e and I_m must be small as compared to I_p .

There are some design features which help us to minimize the errors and they are discussed below :

Design Features

1. Core. In order to minimize the errors the magnetizing current I_m and loss component I_e must be kept to a low value. This means that the core must have a low reluctance and a low core loss. The reduction of reluctance of flux path can be brought about by using materials of high permeability, short magnetic paths, large cross-section of core and a low value of flux density. The current transformers are, in fact, designed for much lower flux densities than that for power transformers. This is especially important for current transformers used for protective relays which are frequently required to have a fair accuracy at currents many times the rated current (20 to 30

times the rated value), in order that the relay operation may be correct in the event of a short circuit on the system, particularly when differential relaying schemes are used.

The number of joints in building up cores should be minimum as far as possible because joints produce air gaps which offer path of high reluctance. The mmf consumed by joints can be reduced by properly lapping the joints and tightly binding the core. The core loss is reduced by choosing materials having low hysteresis and low eddy current losses, and by working the core at low flux densities.

Present-day magnetic materials used in current transformer are divided into three categories :

(i) hot rolled silicon steel ; (ii) cold rolled grain oriented silicon steel ; and (iii) nickel iron alloys.

In current transformer practice hot rolled silicon steels (4% silicon) are used in a variety of forms. For ring type current transformers "ring" stampings are commonly used. For wound type, *T-U*, *L* or *E* and *I* stampings are used. In the highest grades of transformers, the core is built of ring shaped stamping stacked in cylindrical form as shown in Fig. 9'10. An alternative method employs cores that are made of strip wound in spiral form like a clock spring (Fig 9'11). These are called toroidal cores. The latter method is much to be preferred when grain oriented magnetic materials are being as it ensures that the flux path is along the grains and hence there is minimum reluctance. Another advantage of spiral type of cores is that the joints are entirely eliminated.

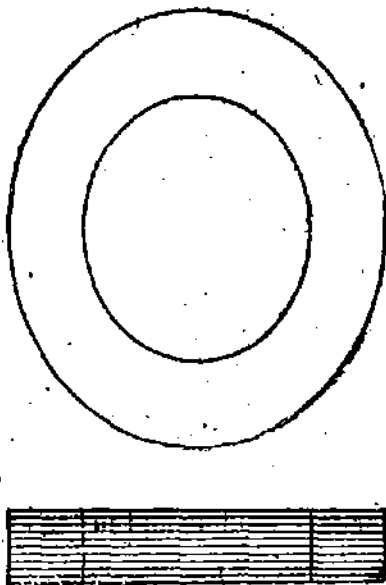

Fig. 9'10. Ring type core.

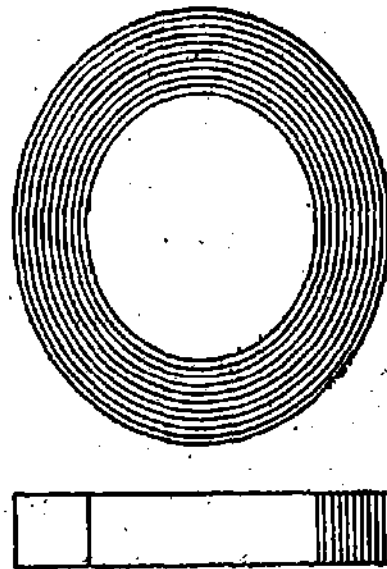

Fig. 9'11. Spiral type core.

High permeability nickel iron cores are used for high precision current transformers. Mumetal (76% Ni) cores are very common as it has the property of high permeability, low loss and small retentivity—all of which are advantageous in current transformer work. But its maximum relative permeability (90,000) occurs with a flux density of only 0.35 Wb/m^2 as compared with maximum relative permeability of silicon steel (4500) occurring at a flux density of about 0.5 Wb/m^2 . Thus Mumetal saturates at low flux density and is, therefore, not useful for protective current transformers like those used for overload relays etc. Also Mumetal (and also other nickel iron alloys) are costlier.

Permender (49% C) has the advantage of a very high saturation density of 2 to 4 Wb/m^2 as compared with 0.7 to 0.8 Wb/m^2 of other high permeability alloys.

Hipernik (50% Fe and 50% Ni) has high permeability at low flux densities and reasonable high saturation density and therefore it is frequently used for current transformers.

2. Primary Current Ratings. Whatever equipment a C.T. is feeding, it is desirable that the ratio of exciting current to primary current should be small. This means that the ratio of excitation mmf to primary mmf should be low. It is difficult to achieve this condition if the latter

quantity (primary current or mmf) is small and an improvement in performance is always obtained by increasing the primary mmf. Satisfactory results can usually be achieved if the total primary mmf at rated current is 500 A. Thus transformers with a rated current of 500 A or more are provided with a single turns primary. Transformers for ratings below 500 A are where possible, provided with multitransformations, if this enable the core size to be reduced.

With the advent of improved magnetic materials and the development of methods for biasing the core to improve permeability single turn primary winding can be used for even 100 A primary current.

3. **Leakage Reactance.** Leakage reactance tends to increase ratio error. Therefore, the two windings, primary and secondary should be close together to reduce the secondary leakage reactance. Use of ring shaped cores around which toroidal windings are uniformly distributed also leads to low leakage reactance.

4. **Turns Compensation.** We have, actual transformation ratio

$$R = n + \frac{I_0}{I_1} \quad (\text{Eqn. 9'20})$$

Thus if we make the "nominal ratio" equal to the turns ratio the actual transformation ratio becomes more than the nominal ratio.

Now if we reduce the turns ratio and keep the nominal ratio equal to the earlier value, the actual transformation ratio will be reduced. This would make actual transformation ratio nearly equal to the nominal ratio. Let us make it clear with the help of an example.

We consider a 1000/5 A current transformer with loss component equal to 0.6 percent of primary current.

$$\text{Its nominal ratio } K_n = \frac{1000}{5} = 200. \quad \text{Loss component } I_0 = \frac{0.6}{100} \times 1000 = 6 \text{ A.}$$

Let the number of primary turns $N_p = 1$.

If the turns ratio is equal to the nominal ratio, we have $n = 200$.

\therefore Secondary turns $N_s = n N_p = 200 \times 1 = 200$.

$$\text{Actual ratio } R = n + \frac{I_0}{I_1} = 200 + \frac{6}{5} = 201.2.$$

Now suppose we do not use 200 turns for the secondary winding and instead use 199 turns.

$$\text{Actual transformation ratio with turn compensation } R = n + \frac{I_0}{I_1} = 199 + \frac{6}{5} = 200.2.$$

Thus we find that by reducing slightly the secondary turns the actual transformation ratio is made nearly equal to the nominal ratio.

Usually the best number of secondary turns is one or two less than the number which would make actual transformation ratio equal to nominal ratio of the transformer. The phase angle error is very little effected by a change of one or two turns in the secondary.

The correction by reduction in secondary winding turns, is exact only for a particular value of current and burden impedance. The C.T. in this case may be called "compensated".

The errors can also be reduced by :

5. **Use of Shunts.** If the secondary current is too large, it may be reduced by a shunt placed across the primary or secondary. This method makes an exact correction only for a particular value and type of burden. It also reduces phase angle error.

6. **Wilson Compensation Method.** Reduction of one or two turns of the secondary winding, no doubt, reduces the ratio error, but it has no effect on the phase angle error. Also this method

is too coarse a method for ratio adjustment and therefore we must use a method which exercises a finer control, say, which is equivalent to reduction to a fraction of a turn.

A compensated type of design was given by S. Wilson of the General Electric Company (Fig. 9'12). This method gives finer adjustments.

It employs a few turns of wire called auxiliary secondary turns passed through a hole in the core and connected in series with the secondary winding. A short circuited turn is placed around one position of core to improve the phase relationships.

The auxiliary turns are connected to magnetize in the same direction around the core as the main secondary winding and thus their effect opposes the flux set up by the primary. The auxiliary turns tend to set up a circulating flux around the hole as indicated by the dotted line in Fig. 9'12 (b). The two fluxes are additive in the section A of the core and subtractive in section B. At low flux densities the addition in flux is equal to the subtraction in flux. However, as the flux densities increase (with larger currents I_p and I_s) section A tends to saturate, so that the flux in section A is no longer linearly proportional to the current and the increase in flux in this portion is less than linear proportional to the current. The action is equivalent to transforming some of the core flux to section B of the core, where it links with the auxiliary turns and gives the effect of increased secondary turns. An increase of secondary turns means a reduction of I_s as compared with an uncompensated transformer causing an increase in ratio R . This action is needed to flatten the curves relating the ratio and phase angle with secondary current (Fig. 9'8 and 9'9) are flattened out so that the errors are practically constant (and of course known over a wide range of secondary current). This is the greatest advantage of this method. The curves can be lowered or raised by adjusting the number of auxiliary turns.

The shorted turns around part of the core makes the flux in that part lag in phase behind the main flux. The action of this turn is like that of a shading band. The small lag effect produced on secondary current I_s brings it closer to primary current I_p and thus the phase angle errors are reduced.

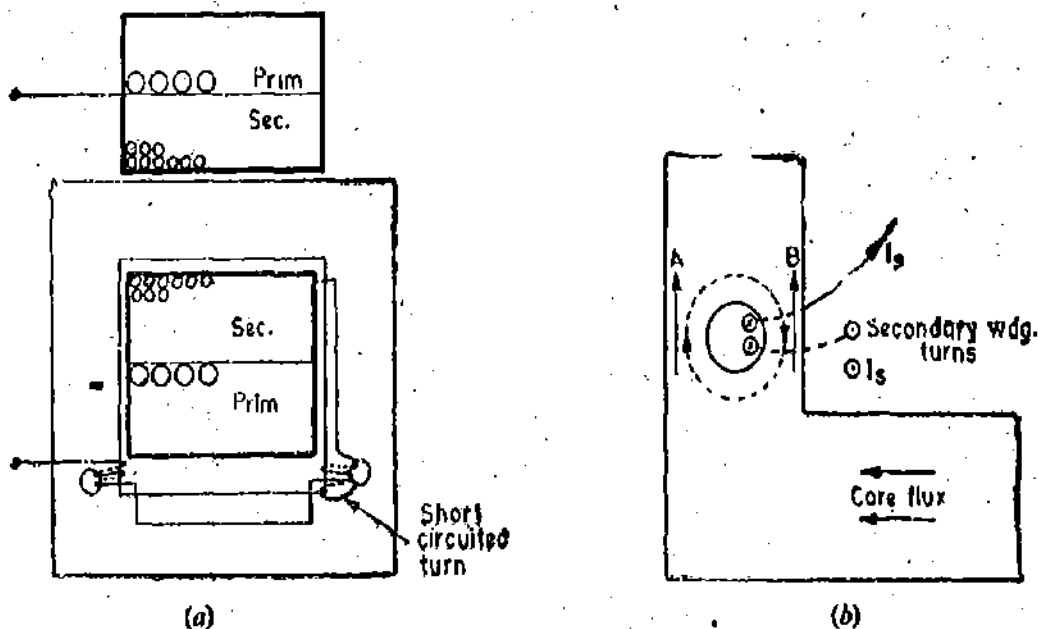

Fig. 9'12. Wilson compensation method.

7. Two Stage Design. This design utilizes a second current transformer to correct the error in secondary current of first transformer. This method in general is applicable to an energy meter because a second coil is needed in the meter to carry the error-correcting current, unless an auxiliary transformer is used.

9'11. Construction of Current Transformers. The current transformers may be classified as :

(i) **Wound type.** A current transformer having a primary winding of more than one full turn wound on core.

(ii) **Bar type.** A current transformer in which the primary winding consists of a bar of suitable size and material forming an integral part of transformer.

Figs. 9'13 and 9 14 shows wound type and bar type transformers respectively.

The simplest form any current transformer can take is the ring type or window type, examples of which are given in Fig. 2'15 which shows three commonly used shapes *i.e.*, stadium, circular and rectangular orifices. The core, if of a nickel-iron alloy or an oriented electrical steel is almost certainly of the continuously wound type. But current transformer using hot rolled steel will consist of stack of ring stampings. Before putting secondary winding on the core, the latter is insulated by means of end collars and circumferential wraps of elephantide or presspahn. These pressboards, in addition to acting as insulating medium, must also protect the secondary winding conductor from mechanical damage due to sharp corners. The secondary winding conductor is put on the core by a toroidal winding machine although hand winding is still frequently adopted if the number of secondary turns is small.

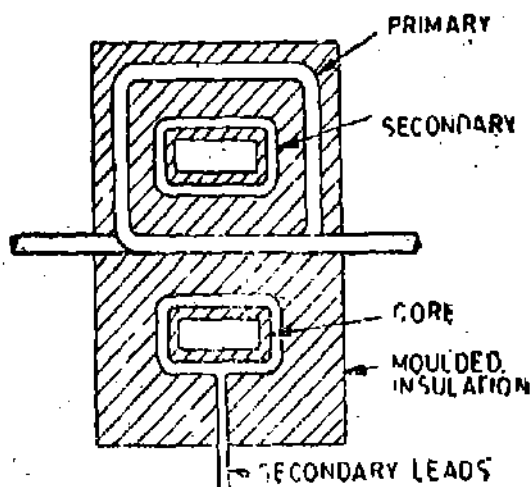

Fig. 9'13. Wound type C.T.

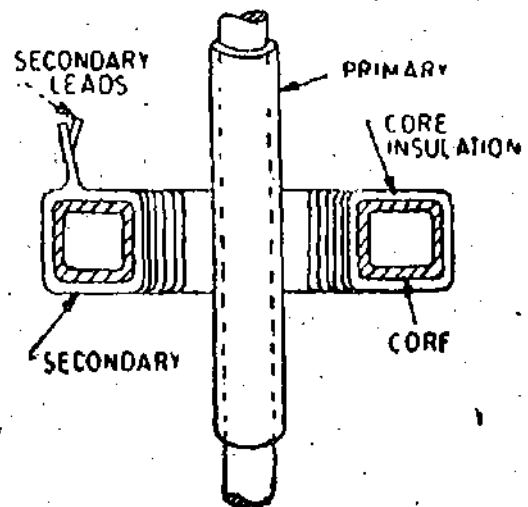

Fig. 9 14. Bar type C.T.

After the secondary winding has been placed on the core, the ring type transformer is completed by exterior taping with or without first applying exterior and rings and circumferential insulating wraps.

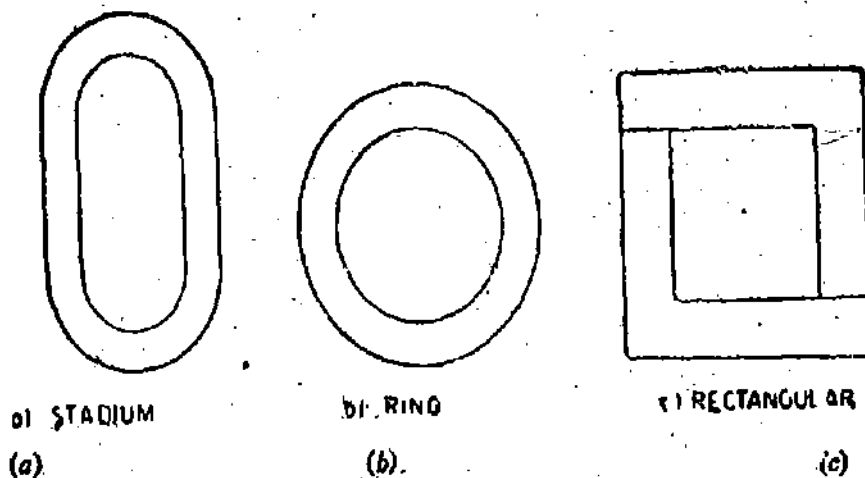

Fig. 9'15. Stampings for window type C.Ts.

A near relative of the ring type current transformer is the so called "bushing type" transformer. This is, in fact, indistinguishable from the ordinary ring type but the term is used when the current transformer fits over a fully insulated primary conductor such as over the oil end of a terminal bushing of a power transformer or oil circuit breaker.

At very high voltages, the insulation of the current carrying conductor from the measuring circuit becomes an expensive problem. At 750 kV, cascaded current transformers are used or alternatively a coaxial shunt is used to modulate a radio frequency signal that is transmitted from the shunt placed in the high voltage line to receiving equipment on the ground, thereby overcoming the insulation problem. However, this type of system has severe limitation in its power output which has to be amplified in order to operate relays etc.

In a split core current transformer (Fig. 9'16), the core is split, each half having two finely ground or lapped gap faces. These current transformers are assembled on to the primary conductor "on site" for either permanent or temporary duty.

In a bar type current transformer, the core and secondary windings are the same as in a ring type transformer but the fully insulated bar conductor constituting the single turn primary is now an integral part of the current transformer. The insulation on the primary conductor may be bakelized paper tube or a resin directly moulded on the bar.

In a low voltage wound type current transformers the secondary winding is wound on a bakelite former or bobbin and the heavy primary conductor is either wound directly on top of secondary, suitable insulation being first applied over the secondary winding or the primary is wound entirely separately, taped with suitable insulating material and then assembled with the secondary winding on the core.

In the manufacture of current transformers the assembly of lamination stacks demands somewhat greater care than ordinary transformers in order to keep down the reluctance of the interleaved corners as low as possible so as to minimize the magnetizing current. Sometimes cut cores are used.

Whenever possible secondary windings should utilize the whole available winding length on the core, the secondary turns being suitably spaced to accomplish this and the insulation between secondary winding and core and earth must be capable of withstanding the high peak voltages caused if the secondary winding is open circuited when primary current is flowing. In the case of a large number of secondary turns, requiring more than one winding layer, the frequently adopted technique is to sectionalize the secondary winding so as to considerably reduce the peak voltage between layers.

With wound primary current transformers this particular problem is rarely met but it is of importance to try to obtain good relative positioning of primary and secondary coils, thus minimizing the axial forces on both coils caused by primary short circuit currents.

Windings. The windings should be close together to reduce the secondary leakage reactance as the leakage reactance increases the ratio error. Round copper wire of about 3 mm² area is frequently used for secondary windings rated at 5 A. Copper strip is used for primary winding, the dimensions of which depend upon the primary current.

When using bar primary, the external diameter of the tube must be large enough to keep the voltage gradient, in the dielectric at its surface, to an acceptable value in order to avoid corona effect.

The windings must be designed to withstand, without damage, the large short circuit forces that are caused when a short circuit takes place on the system in which the current transformer is connected.

The windings are separately wound, and are insulated by tape and varnish for small line voltages. For voltages above 7 kV the transformers are oil immersed or compound filled.

9'12. Clamp on Ammeters. A current transformer with a single conductor is used in combination with a bridge rectifier and a d.c. milli-ammeter to produce a very useful service meter. The core of the transformer can be split with the help of a trigger switch (Fig. 9'16) and therefore the core can be clamped around a live conductor to measure the current. Thus this arrangement avoids the necessity of breaking the circuit in order that a current measuring device be inserted in series with it to measure the value of current flowing. By changing the shunt resistance of the milli-ammeter circuit ranges from 0-5 A to 0-600 A can be obtained.

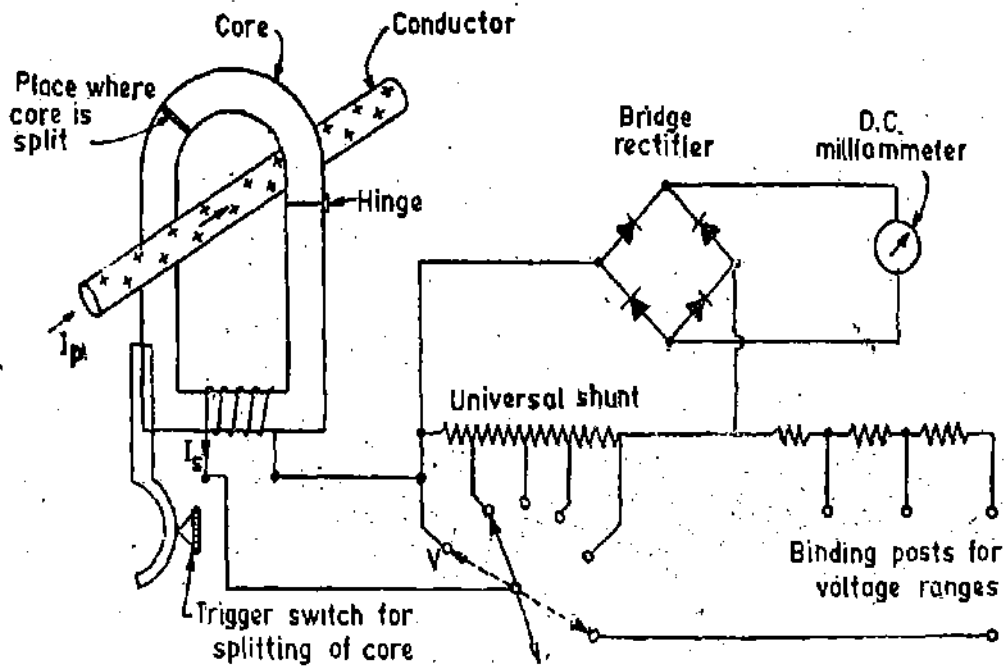

Fig. 9'16. Combined voltmeter and clamp on ammeter circuit.

Range selector switch for current ranges, Position *V* used for measuring voltage.

The same milli-ammeter and rectifier are used with two external binding posts and a range selecting switch for a multi-range a.c. voltmeter.

This type of clamp-on transformer (or split core transformer) is used with recording ammeters. These transformers are designed for a voltage of 5 kV between the primary and the secondary windings. There are several variations of this clamp on transformer which are used for measuring maximum current in a line, real and reactive powers, and the power factor.

9'13. Effect of Secondary Open Circuit. Current transformers are always used with the secondary circuit closed through ammeters, wattmeter current coils, or relay coils. A precaution which should always be observed in using current transformers is the following :

Never open the secondary circuit of a current transformer while its primary is energised. Failure to observe this precaution may lead to serious consequences both to the operating personnel and to the transformer. This is clear from the following :

The difference between a power transformer and a current transformer is that in a power transformer the current flowing in the primary winding is largely the reflection of that flowing in the secondary circuit, whereas in the current transformer, the primary winding is connected in series with the line whose current is being measured or indicated and this current is in no way controlled or determined by the conditions of the secondary circuit of the current transformer.

Under normal operating conditions both primary and secondary windings produce mmfs which act against each other. The secondary mmf is slightly less than the primary mmf and consequently the resultant mmf is small. This resultant mmf is responsible for production of flux in the core and as this mmf is small, the flux density is quite low under normal operating conditions and hence a small secondary voltage is induced.

If winding is open circuited when the primary is carrying current, the primary mmf remains the same while the opposing secondary mmf reduces to zero. Therefore the resultant mmf is equal to the primary mmf $I_p N_p$, which is very large. This large mmf produces a large flux in the core till it saturates. This large flux linking the turns of the secondary winding, would induce a high secondary voltage which could be dangerous to the transformer insulation (although modern CTs are designed to withstand this voltage) and to the person who has opened the circuit. Also the eddy current and hysteresis losses would be very high under these conditions and due to this the trans-

former may be overheated and completely damaged. Even if it does not happen, the core may become permanently magnetized and this gives appreciable ratio and phase angle errors.

Many current transformers are provided with a short circuiting link or a switch at the secondary terminals. If such a link is provided, it should always be closed before any change is made in the secondary circuit with primary excited. The secondary winding can safely be short-circuited since when used for measurement it is practically short-circuited as the impedance of the burden *i.e.* an ammeter or a current coil of a wattmeter is very small.

8.14. Permanent Magnetization and its Demagnetization. The permanent magnetization of core may result from any of the following effects :

(i) When the secondary is open-circuited with primary energized. This causes a large magnetization force which produces a high value of flux density in the core. Now when this force is taken off, it leaves a large residual magnetism.

(ii) A switching transient may leave behind a residual magnetism.

(iii) Permanent magnetization may also result from d.c. current in either winding. This may be due to passage of d.c. current through the windings for finding resistance or to check the polarity. Permanent magnetization may also be due to transient short circuit currents contained in the line in which it is connected. These currents contain d.c. current components in addition to a.c. currents.

The presence of permanent magnetization in the core of a C.T. may reduce its permeability at the flux densities at which it is normally operated and, therefore, results in increase of both its ratio and phase angle errors. Thus, for proper current transformer operation, this permanent magnetization should be removed and the transformer restored to its normal conditions.

Demagnetization of Core. There are several methods of demagnetization of core and the following two methods are usually adopted :

1. The first method is to pass a current through the primary winding equal to that which was passing when C.T. secondary open circuit took place. The secondary circuit is left open. The primary current is drawn from a motor alternator set. The motor is shut down with alternator field still excited. As the speed of the set falls the alternator voltage gradually falls to zero, and the core of the C.T. is passed through a large number of cycles of magnetization of gradually decreasing amplitude, finishing at zero magnetization.

2. In the second method, the primary winding is excited with full current and a very high variable resistance of several hundred ohm is connected across the secondary. This amounts to practically open circuiting the transformer. This secondary resistance is then gradually reduced to zero as uniformly as possible. By this means the magnetization of the transformer core is reduced from a very high value its normal value gradually.

9.15. Current Transformers for High Frequencies. There are certain applications for which current transformers are used to extend the current range of instruments working at high frequencies. One of these applications is extension of current range of thermocouple instruments which are mainly used at high frequencies. Ordinary silicon steel cores are not used for these current transformers as they would result in considerable core loss (and also non-uniform distribution of flux in the cross-section of the core) resulting in large errors. The current transformers used at high frequencies are either air cored or use dust cores.

The theory of these current transformers is developed from a different concept since the leakage reactance of windings in air cored coils is considerably large as compared to the one in iron cored coils.

Let

- L_p = self-inductance of primary winding ; H,
- L_s = self-inductance of secondary winding ; H,
- M = mutual inductance between primary and secondary windings ; H,
- R_s = resistance of secondary winding circuit ; Ω ,

I_p = primary winding current ; A,

I_s = secondary winding current ; A,

K = co-efficient of coupling

f = frequency ; Hz,

$\omega = 2\pi f$ = angular frequency, rad/s.

Emf induced in the secondary winding, $E_s = -j\omega MI_p$

Current through the secondary winding circuit, $I_s = \frac{-j\omega MI_p}{R_s + j\omega L_s}$

\therefore Transformation ratio, $R = \frac{I_p}{I_s}$

$$= \frac{R_s + j\omega L_s}{-j\omega M} = \frac{j\omega L_s}{-j\omega M} \left(1 + \frac{R_s}{j\omega L_s} \right) = -\frac{L_s}{M} \left(1 + \frac{1}{jQ_s} \right)$$

where

$$Q_s = \text{storage factor of secondary winding} = \frac{\omega L_s}{R_s}$$

The magnitude ratio is $R = \frac{I_p}{I_s} = \frac{L_s}{M} \sqrt{1 + \frac{1}{Q_s^2}}$... (9'24)

At high frequencies storage factor Q_s is very high and even if $Q_s > 5$ the term $1/Q_s^2$ becomes very small as compared to unity.

Hence, we can write Eqn. 9'24 as : $R = \frac{I_p}{I_s} \approx \frac{L_s}{M}$... (9'25)

But $M = K\sqrt{L_p L_s}$

\therefore Ratio $R = \frac{L_s}{M} = \frac{L_s}{K\sqrt{L_p L_s}} = \frac{1}{K} \sqrt{\frac{L_s}{L_p}}$... (9'26)

It is clear from above relationships (Eqns. 9'25 and 9'26) that the current ratio is independent of the frequency in case storage factor is secondary winding Q_s is greater than 5.

Example 9'1. A current transformer has a single turn primary and a 200 turns secondary winding. The secondary supplies a current of 5 A to a non-inductive burden of 1 Ω resistance. The requisite flux is set up in the core by an mmf of 80 A. The frequency is 50 Hz and the net cross section of the core is 1000 mm².

Calculate the ratio and phase angle of the transformer. Also find the flux density in the core. Neglect the effects of magnetic leakage, iron losses and copper losses.

Solution. If we neglect the magnetic leakage, the secondary leakage reactance becomes zero. Therefore, the secondary burden is purely resistive and the impedance of burden is equal to the resistance of the secondary winding.

\therefore Impedance of secondary circuit = 1 Ω .

Voltage induced in the secondary winding

$$E_s = \text{current in the secondary} \times \text{impedance of secondary winding} = 5 \times 1 = 5 \text{ V.}$$

As the secondary burden is purely resistive, the secondary current is in phase with secondary induced voltage and the secondary power factor is unity or $\delta = 0$.

The loss component of no load current is to be neglected and, therefore,

$$I_w = 0$$

$$\therefore \text{Exciting current } I_0 = \sqrt{I_m^2 + I_w^2} = I_m = \text{magnetizing component}$$

and $\alpha = 0.$

Magnetizing component of no load current

$$I_m = \frac{\text{magnetizing mmf}}{\text{primary winding turns}} = \frac{80}{1} = 80 \text{ A.}$$

Secondary current $I_s = 5 \text{ A.}$

Reflected secondary current $= n I_s = 200 \times 5 = 1000 \text{ A}$

The phasor diagram is shown in Fig. 9.17.

$$\therefore \text{Primary current } I_p = \sqrt{(nI_s)^2 + (I_m)^2} = \sqrt{(1000)^2 + (80)^2} = 1003.2 \text{ A.}$$

Actual transformation ratio $R = \frac{I_p}{I_s} = \frac{1003.2}{5} = 200.64.$

Phase angle $\theta = \tan^{-1} \frac{I_m}{nI_s} = \tan^{-1} \frac{80}{1000} = 4^\circ 35'$

We know $E_s = 4.45 f \Phi_m N_s$

$$\therefore \text{Maximum flux } \Phi_m = \frac{E_s}{4.44 f N_s} = \frac{5}{4.44 \times 50 \times 200} = 0.1125 \times 10^{-3} \text{ Wb.}$$

Area of core $= 1000 \text{ mm}^2 = 1000 \times 10^{-6} \text{ m}^2$

$$\therefore \text{Maximum flux density } B_m = \frac{0.1125 \times 10^{-3}}{1000 \times 10^{-6}} = 0.1125 \text{ Wb/m}^2.$$

Example 9.2. The magnetizing current of a ring core current transformer, of ratio 1000/5 A, when operating at full primary current and with a secondary burden of non-inductive resistance of 1 Ω is 1 A at a power factor of 0.4.

- Calculate : (i) the phase displacement between primary and secondary currents ;
- (ii) the ratio error at full load, assuming that there has been no compensation.

Solution. The secondary burden is purely resistive and, therefore, secondary p.f. is unity, or $\delta = 0.$ Referring to Fig. 9.18

The p.f. of exciting current is 0.4. $\therefore \cos(90 - \alpha) = 0.4$ or $\alpha = 23^\circ 36'$

Exciting current $I_0 = 1 \text{ A.}$ Nominal ratio $K_n = \frac{1000}{5} = 200.$

Since there is no turn compensation, the turns ratio is equal to nominal ratio or $n = K_n = 200.$

When the primary winding carries rated current of 1000 A secondary winding carries a current of 5 A.

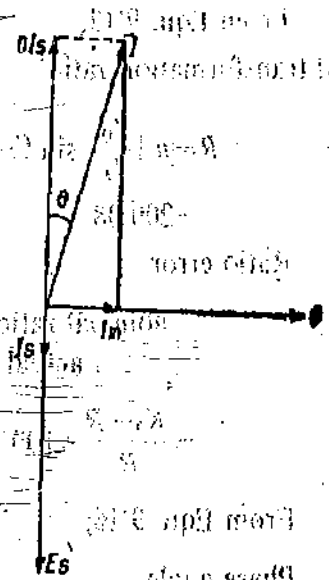

Fig. 9.17

Rated secondary current $I_s = 5$ A

$$\therefore n I_s = 200 \times 5 = 1000 \text{ A.}$$

From Eqn. 9'13,

actual transformation ratio

$$R = n + \frac{I_0}{I_s} \sin(\delta + \alpha) = 200 + \frac{1}{5} \sin(0 + 23^\circ 36')$$

$$= 200.08$$

Ratio error

$$= \frac{\text{nominal ratio} - \text{actual ratio}}{\text{actual ratio}} \times 100$$

$$= \frac{K_n - R}{R} \times 100 = \frac{200 - 200.08}{200.08} \times 100 = -0.04\%$$

From Eqn 9'16,

Phase angle

$$\theta = \frac{180}{\pi} \left[\frac{I_0 \cos(\delta + \alpha)}{n I_s} \right] = \frac{180}{\pi} \left[\frac{\cos 23^\circ 36'}{1000} \right]$$

$$= 0.0525^\circ = 3' 9''.$$

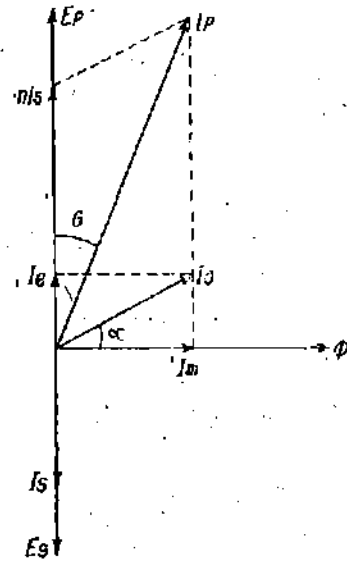

Fig. 9'18

Example 9'3. A 1000/5 A, 50 Hz current transformer has a secondary burden comprising a non-inductive burden of 1.6Ω . The primary winding has one turn. Calculate the flux in the core and ratio error at full load. Neglect leakage reactance and assume the iron loss in the core to be 1.5 W at full load.

Solution : Nominal ratio $K_n = \frac{1000}{5} = 200.$

The turns ratio is assumed equal to the nominal ratio in the absence of any other data.

\therefore Turns ratio $n = K_n = 200$ Primary winding turns $N_p = 1$

\therefore Secondary winding turns $N_s = n N_p = 200$ Secondary impedance $= 1.6 \Omega$

\therefore Secondary induced voltage $E_s = 5 \times 1.6 = 8$ V We have $E_s = 4.44 f \Phi_m N_s.$

or Maximum flux $\Phi_m = \frac{E_s}{4.44 f N_s} = \frac{8}{4.44 \times 50 \times 200} = 180 \times 10^{-6}$ Wb.

Primary induced voltage $E_p = \frac{E_s}{n} = \frac{8}{200}$ V. Iron loss $= 1.5$ W.

Loss component $I_e = \frac{\text{iron loss}}{E_p} = \frac{1.5}{8/200} = 37.5$ A.

The magnetizing component I_m is assumed to be zero as there is no data given,

$$I_m = 0.$$

As the burden is purely resistive and, therefore, the secondary load angle is assumed zero

$$\delta = 0.$$

or

From Eqn. 9'14,

Actual ratio $R = n + \frac{I_m \sin \delta + I_e \cos \delta}{I_s} = 200 + \frac{37.5}{5} = 207.5.$

Ratio error $= \frac{K_n - R}{R} \times 100 = \frac{200 - 207.5}{207.5} \times 100 = -3.61\%.$

Example 9.4. A current transformer with a bar primary has 300 turns in its secondary winding. The resistance and reactance of the secondary circuit are 1.5Ω and 1.0Ω respectively including the transformer winding. With 5 A flowing in the secondary winding, the magnetizing mmf is 100 A and the iron loss is 1.2 W. Determine the ratio and phase angle errors.

Solution : Primary turns $N_p = 1$, Secondary turns $N_s = 300$.

$$\therefore \text{Turns ratio } n = \frac{N_s}{N_p} = 300.$$

$$\text{Secondary burden impedance} = \sqrt{(1.5)^2 + (1.0)^2} = 1.8 \Omega.$$

Secondary circuit power factor :

$$\cos \delta = \frac{\text{resistance}}{\text{impedance}} = \frac{1.5}{1.8} = 0.833 \quad \text{and} \quad \sin \delta = \frac{\text{reactance}}{\text{impedance}} = \frac{1.0}{1.8} = 0.555.$$

$$\text{Secondary induced voltage } E_s = 5 \times 1.8 = 9.0 \text{ V.} \quad \text{Primary induced voltage } E_p = \frac{E_s}{n} = \frac{9}{300} \text{ V.}$$

$$\text{Loss component of current referred to primary } I_o = \frac{\text{iron loss}}{E_p} = \frac{1.2}{9/300} = 40 \text{ A.}$$

$$\text{Magnetizing current } I_m = \frac{\text{magnetizing mmf}}{\text{primary winding turns}} = \frac{100}{1} = 100 \text{ A.}$$

$$\text{Actual ratio } R = n + \frac{I_o \cos \delta + I_m \sin \delta}{I_s} = 300 + \frac{40 \times 0.833 + 100 \times 0.555}{5} = 317.6.$$

In the absence of any information to the contrary we can take nominal ratio to be equal to the turns ratio,

$$\text{or} \quad K_n = n = 300.$$

$$\text{Percentage ratio error} = \frac{K_n - R}{R} \times 100 = \frac{300 - 317.6}{317.6} = -5.54\%.$$

From Eqn. 9.18, we have

$$\text{Phase angle } \theta = \frac{180}{\pi} \left(\frac{I_m \cos \delta - I_o \sin \delta}{n I_s} \right) = \frac{180}{\pi} \left(\frac{100 \times 0.833 - 40 \times 0.555}{300 \times 5} \right) = 2.34^\circ.$$

Example 9.5. A current transformer has a bar primary and 200 secondary turns. The secondary burden is an ammeter of resistance 1.2Ω and reactance 0.5Ω , the secondary winding has a resistance of 0.2Ω and reactance 0.3Ω . The core requires the equivalent of an mmf of 100 A for magnetization and 50 A for core losses.

(i) Find the primary current and ratio error when the secondary ammeter indicates 5 A.

(ii) By how many turns could the secondary winding be reduced in order that the ratio error be zero for this condition.

$$\text{Solution. Total secondary circuit resistance} = 1.2 + 0.2 = 1.4 \Omega.$$

$$\text{Total secondary circuit reactance} = 0.5 + 0.3 = 0.8 \Omega.$$

$$\text{Secondary circuit phase angle } \delta = \tan^{-1} \frac{0.8}{1.4} = 29^\circ 42' \quad \text{or} \quad \cos \delta = 0.8686 \quad \text{and} \quad \sin \delta = 0.4955.$$

$$\text{Primary winding turns } N_p = 1 \quad \text{Secondary winding turns } N_s = 200.$$

$$\therefore \text{Turns ratio } n = 200.$$

$$\text{Magnetizing current } I_m = \frac{\text{magnetizing mmf}}{\text{primary turns}} = \frac{100}{1} = 100 \text{ A.}$$

Loss component $I_0 = \frac{\text{mmf equivalent to iron loss}}{\text{primary winding turns}} = \frac{50}{100} = 50 \text{ A}$

Actual ratio $R = n + \frac{I_0 \cos \delta + I_m \sin \delta}{I_2} = 200 + \frac{50 \times 0.8686 + 100 \times 0.4955}{5} = 218.6$

Primary current $I_1 = \text{actual transformation ratio} \times \text{secondary current} = 218.6 \times 5 = 1093 \text{ A}$

(ii) In order to eliminate the ratio error, we must reduce the secondary turns or in other words we must reduce the turns ratio.

The nominal ratio is 200 and therefore, for zero ratio error the actual transformation ratio should be equal to the nominal ratio,

Nominal ratio $K_n = 200$.

Actual ratio $R = n + \frac{I_0 \cos \delta + I_m \sin \delta}{I_2}$. For zero ratio error $K_n = R$

$200 = n + \frac{50 \times 0.8686 + 100 \times 0.4955}{5} = n + 18.6$

Turns ratio $n = 181.4$

Hence secondary winding turns $N_s = n N_p = 181.4 \times 1 = 181.4$

Reduction in secondary winding turns $= 200 - 181.4 = 18.6$

Example 9.6. The primary magnetizing current of a current transformer with a bar primary, nominal ratio 100/1, operating on an external burden of 1.6 Ω non-inductive, the secondary winding resistance being 0.2 Ω, is 1.9 A, lagging 0.65 to the secondary voltage reversed there being 100 secondary turns. With 1 A flowing in the secondary, calculate (i) the actual ratio of primary current to secondary current, (ii) the phase angle between them in minutes.

Solution. Primary winding turns $N_p = 1$. Secondary winding turns $N_s = 100$.

∴ Turns ratio $n = \frac{N_s}{N_p} = 100$.

Total secondary circuit resistance $= 1.6 + 0.2 = 1.8 \Omega$. Secondary circuit reactance $= 0$.

∴ The secondary p.f. is unity and its phase angle $\delta = 0$. Exciting current $I_0 = 1.9 \text{ A}$.

(This current is exciting current and not magnetizing current according to terminology used in this book.)

$\alpha = \text{angle between } I_0 \text{ and } \Phi = 90^\circ - (\text{angle between } I_0 \text{ and } E, \text{ reversed}) = 90^\circ - 40.6^\circ = 49.4^\circ$

$\cos \alpha = 0.65$ and $\sin \alpha = 0.76$.

Actual ratio $R = n + \frac{I_0 \sin(\delta + \alpha)}{I_2}$ (See Eqn. 9.13)

$= 100 + \frac{1.9}{1.0} \sin(0^\circ + 49.4^\circ) = 101.44$

Phase angle $\theta = \frac{180}{\pi} \cdot \frac{I_0 \cos(\delta + \alpha)}{n I_2}$ degree $= \frac{180}{\pi} \times 1.9 \frac{\cos 49.4^\circ}{100 \times 1} = 0.708^\circ = 42.5'$

Example 9.7. A 100/5 A, 50 Hz current transformer has a bar primary and a rated secondary burden of 12.5 VA. The secondary winding has 196 turns and a leakage inductance of 0.96 mH. With a purely resistive burden at rated full load, the magnetization mmf is 16 A and the loss excitation requires 12 A. Find the ratio and phase angle errors.

Solution. Secondary burden $= 12.5 \text{ VA}$. Secondary winding current $I_2 = 5 \text{ A}$.

∴ Secondary circuit impedance = $\frac{12.5}{(5)^2} = 0.5 \Omega$

Secondary circuit reactance = $2\pi \times 50 \times 96 \times 10^{-3} = 0.3 \Omega$

Phase angle of secondary circuit $\delta = \sin^{-1} \frac{0.3}{0.5} = \sin^{-1} 0.6$

∴ $\sin \delta = 0.6$ and $\cos \delta = \sqrt{(1)^2 - (0.6)^2} = 0.8$

Primary winding turns $N_p = 1$. Secondary winding turns $N_s = 196$.

Turns ratio $n = N_s/N_p = 196$. Nominal ratio $K_n = \frac{1000}{5} = 200$.

Magnetizing current $I_m = \frac{\text{magnetizing mmf}}{\text{primary winding turns}} = \frac{16}{1} = 16 \text{ A}$.

Loss component $I_s = \frac{\text{excitation for loss}}{\text{primary winding turns}} = \frac{12}{1} = 12 \text{ A}$.

Actual ratio $R = n + \frac{I_s \cos \delta + I_m \sin \delta}{I_s} = 196 + \frac{12 \times 0.8 + 16 \times 0.6}{5} = 199.84$.

Ratio error = $\frac{\text{nominal ratio} - \text{actual ratio}}{\text{actual ratio}} \times 100 = \frac{200 - 199.84}{199.84} \times 100 = +0.08\%$.

Phase angle $\theta = \frac{180}{\pi} \left[\frac{I_m \cos \delta - I_s \sin \delta}{n I_s} \right] = \frac{180}{\pi} \left[\frac{16 \times 0.8 - 12 \times 0.6}{196 \times 5} \right] = 0.327^\circ = 19.6'$.

Example 9.8. A current transformer of turns ratio 1 : 199 is rated as 1000/5 A, 25 VA. The core loss and magnetizing component of the primary current are 4 and 7 A under rated conditions. Determine the phase angle and ratio errors for the rated burden and rated secondary current at 0.8 p.f. lagging and 0.8 p.f. leading. Neglect the resistance and leakage resistance of secondary winding.

Solution :

Primary winding turns $N_p = 1$. Secondary winding turns $N_s = 199$. Turns ratio $n = 199$.

Normal ratio $K_n = \frac{1000}{5} = 200$.

Magnetizing current $I_m = 7 \text{ A}$. Loss component $I_s = 4 \text{ A}$.

0.8. P.F. Lagging

For lagging p.f. the secondary phase angle δ is positive.

$\cos \delta = \text{secondary p.f.} = 0.8$, $\sin \delta = \sqrt{(1)^2 - (0.8)^2} = 0.6$.

From Eqn. 9.14, actual ratio, $R = n + \frac{I_s \cos \delta + I_m \sin \delta}{I_s} = 199 + \frac{4 \times 0.8 + 7 \times 0.6}{5} = 200.48$.

∴ Ratio error = $\frac{K_n - R}{R} \times 100 = \frac{200 - 200.48}{200.48} \times 100 = -0.24\%$

and Phase angle $\theta = \frac{180}{\pi} \left[\frac{I_m \cos \delta - I_s \sin \delta}{n I_s} \right] = \frac{180}{\pi} \left[\frac{7 \times 0.8 - 4 \times 0.6}{199 \times 5} \right] = +0.185^\circ = +11'$

0.8. P.F. Leading

For leading p.f. δ is negative. $\cos \delta = 0.8$ and $\sin \delta = -0.6$.

$$\text{Actual ratio } R = n \frac{I_e \cos \delta + I_m \sin \delta}{I_s} = 199 + \frac{4 \times 0.8 - 7 \times 0.6}{5} = 198.8.$$

$$\therefore \text{Ratio error} = \frac{K_n - R}{R} \times 100 = \frac{200 - 198.8}{198.8} \times 100 = +0.603\%$$

$$\text{and Phase angle } \theta = \frac{180}{\pi} \frac{I_m \cos \delta - I_e \sin \delta}{n I_s} = \frac{180}{\pi} \left[\frac{7 \times 0.8 + 4 \times 0.6}{199 \times 5} \right] = 0.46^\circ = 27.6'.$$

Example 9.9. A current transformer having a 1 turn primary is rated at 500/5A, 50 Hz with an output of 15 VA. At rated load with non-inductive burden, the inphase and quadrature components (referred to the flux) of the exciting mmf are 8 and 10 A respectively. The number of turns in the secondary is 98, and the resistance and leakage reactance of the secondary winding are 0.35 Ω and 0.3 Ω respectively.

Calculate the current and phase angle error.

Solution.

Primary winding turns $N_p = 1$. Secondary winding turns $N_s = 98$. \therefore Turns ratio $n = 98$.

$$\text{Nominal ratio } K_n = \frac{500}{5} = 100.$$

Magnetizing current component is in phase while the loss component is in quadrature with the flux.

\therefore Magnetizing mmf = 8 A, Mmf equivalent to loss = 10 A.

$$\text{Magnetizing current } I_m = \frac{\text{magnetizing mmf}}{\text{primary winding turns}} = \frac{8}{1} = 8 \text{ A.}$$

$$\text{Loss current } I_e = \frac{\text{loss mmf}}{\text{primary winding turns}} = \frac{10}{1} = 10 \text{ A.}$$

Output volt-ampere VA = 15.

$$\text{Impedance of secondary load burden} = \frac{\text{VA}}{I_s^2} = \frac{15}{(5)^2} = 0.6 \Omega.$$

It is given that the external burden is purely resistive.

\therefore Resistance of external burden = 0.6 Ω , Reactance of external burden = 0.

Resistance of total secondary burden = 0.6 + 0.35 = 0.95 Ω .

Reactance of total secondary burden = 0 + 0.3 = 0.3 Ω .

$$\text{Secondary phase angle } \delta = \tan^{-1} \frac{0.3}{0.95} = 17^\circ 30'.$$

So, $\cos \delta = 0.95$ and $\sin \delta = 0.3$.

$$\text{Actual ratio } R = n + \frac{I_e \cos \delta + I_m \sin \delta}{5} = 98 + \frac{10 \times 0.95 + 8 \times 0.3}{5} = 100.38.$$

$$\text{Ratio (current) error} = \frac{100 - 100.38}{100.38} \times 100 = -0.38\%.$$

$$\text{Phase angle } \theta = \frac{180}{\pi} \left[\frac{I_m \cos \delta - I_e \sin \delta}{n I_s} \right] = \frac{180}{\pi} \left[\frac{8 \times 0.95 - 10 \times 0.3}{98 \times 5} \right] = 0.537^\circ.$$

Example 9.10. At its rated load of 25 VA, a 100/5 A current transformer has an iron loss of 0.2 W and a magnetizing current of 1.5 A. Calculate its ratio error and phase angle when supplying rated output to a meter having a ratio of resistance to reactance of 5.

Solution. Normal ratio $K_n = \frac{100}{5} = 20$.

In the absence of any other data, the turns ratio is taken equal to the nominal ratio.

or $n = K_n = 20$.

Neglecting the burden of the secondary winding, the total burden of the secondary circuit is equal to the burden of the meter.

∴ Burden of secondary circuit = 25 VA.

Voltage across primary winding $E_p = \frac{VA}{I_p} = \frac{25}{100} = 0.25$ V.

Loss component of current $I_e = \frac{\text{iron loss}}{E_p} = \frac{0.2}{0.25} = 0.8$ A.

Magnetising current $I_m = 1.5$ A.

Secondary circuit phase angle, $\delta = \tan^{-1} \frac{X}{R} = \tan^{-1} \frac{1}{5} = 11^\circ 18'$

∴ $\cos \delta = 0.98$ and $\sin \delta = 0.196$.

Actual ratio $R = n + \frac{I_e \cos \delta + I_m \sin \delta}{I_s} = 20 + \frac{0.8 \times 0.98 + 1.5 \times 0.196}{5} = 20.215$.

Ratio error $= \frac{K_n - R}{R} \times 100 = \frac{20 - 20.215}{20.215} \times 100 = -1.075\%$.

Phase angle $\theta = \frac{180}{\pi} \left[\frac{I_m \cos \delta - I_e \sin \delta}{n I_s} \right] = \frac{180}{\pi} \left[\frac{1.5 \times 0.98 - 0.8 \times 0.196}{20 \times 5} \right] = 0.75^\circ$.

Example 9.11. The resistance and leakage reactance of the secondary winding of a 500/5 A current transformer are 0.02 and 0.03 Ω respectively. The magnetization characteristics of the transformer are as follows :

Secondary emf	V	0.25	0.5	1.0	1.5	2.5
Primary magnetizing component	A	0.9	1.5	2.5	3.2	4.0
Primary core loss component	A	0.5	1.3	2.7	3.9	4.6

An ammeter and a wattmeter current coil are connected in series with the secondary winding. Their respective resistances are 0.04 and 0.06 Ω and reactances 0.06 and 0.08 Ω . Calculate the ratio and phase angle errors of the C.T. when a current of 5 A passes through the instruments, if there is no turns compensation. What should be the turns ratio to minimize the ratio error for this burden ?

Solution. Normal ratio $K_n = \frac{500}{5} = 100$.

With no turn compensation, the turns ratio is equal to the normal ratio.

∴ Turns ratio $n = K_n = 100$.

Total resistance of secondary circuit = $0.02 + 0.04 + 0.06 = 0.12 \Omega$.

Total reactance of secondary circuit = $0.03 + 0.06 + 0.03 = 0.12 \Omega$.

Secondary phase angle = $\tan^{-1} \frac{X_{sc}}{R} = \tan^{-1} \frac{0.12}{0.12} = 45^\circ$.

$\cos \delta = 0.707$ and $\sin \delta = 0.707$
Total secondary impedance = $\sqrt{(0.12^2 + 0.12^2)} = 0.17 \Omega$.

Secondary induced voltage $E_s = 5 \times 0.17 = 0.85 \text{ V}$.

The characteristics of the current transformer are plotted in Fig. 9.19.

Corresponding to $I_e = 0.85$, we have from Fig. 9.19,

$I_e = 2.4 \text{ A}$ and $I_m = 2.26 \text{ A}$.

Actual ratio $R = n + \frac{I_e \cos \delta + I_m \sin \delta}{I_s}$

$= 100 + \frac{2.4 \times 0.707 + 2.26 \times 0.707}{5}$
 $= 100 + 0.66 = 100.66$.

Ratio error $= -\frac{K_n - R}{R} \times 100 = -\frac{100 - 100.66}{100.66} \times 100$
 $= -0.656\%$.

Phase angle $= \frac{180}{\pi} \left[\frac{I_m \cos \delta - I_e \sin \delta}{n I_s} \right]$
 $= \frac{180}{\pi} \left[\frac{2.26 \times 0.707 - 2.4 \times 0.707}{5 \times 100} \right]$ degree

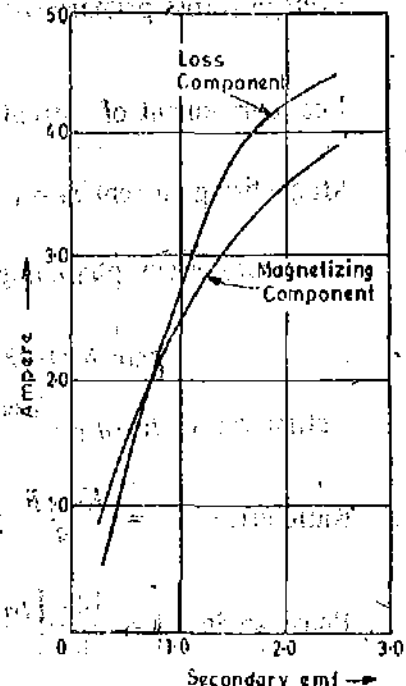

Fig. 9.19

The ratio error can be minimized by making turns ratio $n = 99$.

Actual ratio with $n = 99$ is, $R = 99 + 0.66 = 99.66$. Error = $\frac{100 - 99.66}{99.66} \times 100 = 0.36\%$.

Example 9.12. The range of a thermocouple instrument is extended by an iron cored current transformer. Calculate the value of secondary winding current if the primary winding current is $500 \mu\text{A}$, the primary, secondary and mutual inductances are $50, 500$ and $100 \mu\text{H}$ respectively. The frequency is 1 MHz and secondary circuit resistance is $50 \pi \text{ ohm}$.

Solution : Storage factor of secondary circuit $Q_s = \frac{\omega L_s}{R_s} = \frac{2\pi \times 1 \times 10^6 \times 500 \times 10^{-6}}{50\pi} = 20$

$\frac{1}{Q_s^2} = \frac{1}{(20)^2} = \frac{1}{400}$. Hence $\frac{1}{Q_s^2} \ll 1$.

∴ We can use Eqn. 9.25 for finding the current ratio. Current ratio $R = \frac{L_s}{L_p} = \frac{500 \times 10^{-6}}{50 \times 10^{-6}} = 10$

Secondary winding current $I_s = \frac{I_p}{R} = \frac{500}{10} = 50 \mu\text{A}$.

9.16. Potential Transformers. Potential transformers are used to operate voltmeters, the potential coils of wattmeters and relays from high voltage lines. The primary winding of the trans-

former is connected across the lines carrying the voltage to be measured and the voltage circuit is connected across the secondary winding.

The design of a potential transformer is quite similar to that of a power transformer but the loading of a potential transformer is always small, sometimes only a few volt-ampere. The secondary winding is designed so that a voltage of 100 to 120 V is delivered to the instrument load. The normal secondary voltage rating is 110 V.

9'17. Difference between C.T. and P.T. There are a few differences in the operation of a current transformer and a potential transformer.

(i) The potential transformer may be considered as a 'parallel' transformer with its secondary nearly under open circuit conditions whereas the current transformer may be thought as a 'series' transformer under virtual short circuit conditions. Thus the secondary of a P.T. can be open-circuited without any damage being caused either to the operator or to the transformer.

(ii) The primary current in a C.T. is independent of the secondary circuit conditions while the primary current in a P.T. certainly depends upon the secondary burden.

(iii) In a potential transformer, full line voltage is impressed upon its terminals whereas a C.T. is connected in series with one line and a small voltage exists across its terminals. However, the C.T. carries the full line current.

(iv) Under normal operation the line voltage is nearly constant and, therefore, the flux density and hence the exciting current of a potential transformer varies only over a restricted range whereas the primary current and excitation of a C.T. vary over wide limits in normal operation.

9'18. Theory. The theory of a potential transformer is essentially the same as that of a power transformer. The main point of difference is that the power loading of a P.T. is very small and consequently the exciting current is of the same order as the secondary current while in a power transformer the exciting current is a very small fraction of secondary load current.

Figs. 9'20 and 9'21 show the equivalent circuit and phasor diagram respectively of a potential transformer.

- Φ = working flux,
- I_m = magnetizing component of no load (exciting) current,
- I_e = iron loss component of no load (exciting) current,
- I_0 = no load (exciting) current,
- E_s = secondary winding induced voltage,
- V_s = secondary winding terminal voltage,
- N_p = primary winding turns

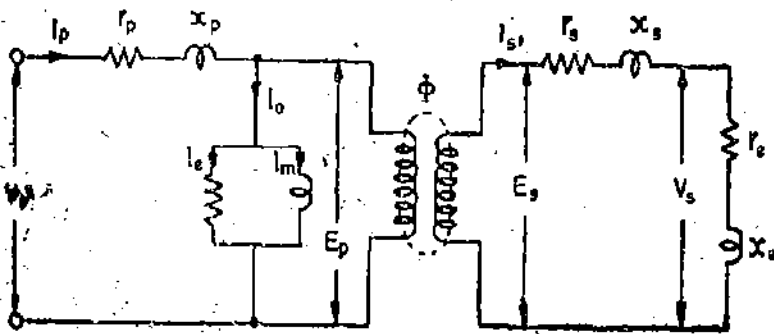

Fig. 9'20. Equivalent circuit of a potential transformer.

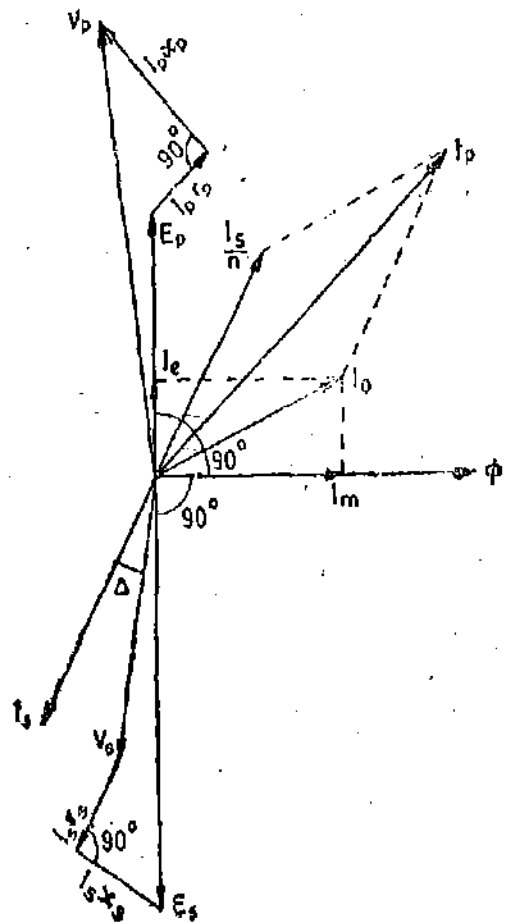

Fig. 9'21. Phasor diagram of a potential transformer.

N_s = secondary winding turns, I_s = secondary winding current,
 r_s = resistance of secondary winding, x_s = reactance of secondary winding,
 r_L = resistance of secondary load circuit, x_L = reactance secondary load circuit

Δ = phase angle of secondary load circuit = $\tan^{-1} \frac{x_L}{r_L}$.

E_p = primary winding induced voltage, I_p = primary winding current,
 r_p = resistance of primary winding, x_p = reactance of primary winding.

Turns ratio $n = \frac{N_p}{N_s}$ $\therefore \frac{E_p}{E_s} = n$.

Secondary voltages when referred to primary side are to be multiplied by n . When secondary currents are referred to primary side, they must be divided by n .

Actual Transformation ratio. An enlarged concise phasor diagram is shown in Fig. 9'22.

- θ = phase angle of the transformer
- = angle between V_p and V_s reversed
- Δ = phase angle of secondary load circuit
- β = phase angle between I_p and V_s reversed.

Now $oa = V_p \cos \theta$.

From the phasor diagram

$$oa = nV_s + nI_s r_s \cos \Delta + nI_s x_s \sin \Delta + I_p r_p \cos \beta + I_p x_p \sin \beta$$

or $V_p \cos \theta = nV_s + nI_s r_s \cos \Delta + nI_s x_s \sin \Delta + I_p r_p \cos \beta + I_p x_p \sin \beta$

$$= nV_s + nI_s (r_s \cos \Delta + x_s \sin \Delta) + I_p r_p \cos \beta + I_p x_p \sin \beta \dots (i)$$

Phase angle θ is very small and, therefore, both V_p and V_s reversed can be taken perpendicular to Φ and, hence,

$\angle ocd = \beta$ (approximately) and $\angle ecd = \Delta$ (approximately).

Thus $I_p \cos \beta = I_e + \frac{I_s}{n} \cos \Delta$ and $I_p \sin \beta = I_m = \frac{I_s}{n} \sin \Delta$.

Now θ is very small usually less than 1° and, therefore, $\cos \theta = 1$ and hence we can write

$V_p \cos \theta = V_p$

Substituting the above values in (i), we have :

$$V_p = nV_s + nI_s (r_s \cos \Delta + x_s \sin \Delta) + \left(I_e + \frac{I_s}{n} \cos \Delta \right) r_p + \left(I_m + \frac{I_s}{n} \sin \Delta \right) x_p$$

$$= nV_s + I_s \cos \Delta \left(n r_s + \frac{r_p}{n} \right) + I_s \sin \Delta \left(n x_s + \frac{x_p}{n} \right) + I_e r_p + I_m x_p \dots (9'27)$$

$$= nV_s + \frac{I_s}{n} \cos \Delta (n^2 r_s + r_p) + \frac{I_s}{n} \sin \Delta (n^2 x_s + x_p) + I_e r_p + I_m x_p$$

$$= nV_s + \frac{I_s}{n} \cos \Delta R_p + \frac{I_s}{n} \sin \Delta X_p + I_e r_p + I_m x_p$$

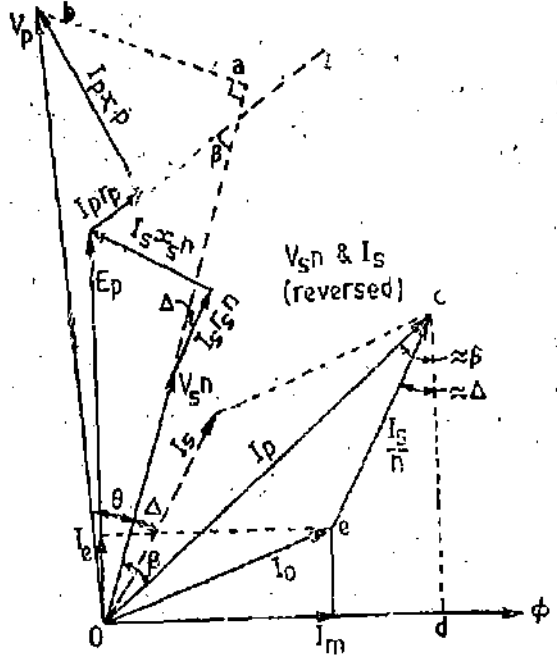

Fig. 9'22. Enlarged and concise phasor diagram of a potential transformer.

$$= nV_s + \frac{I_s}{n} (R_p \cos \Delta + X_p \sin \Delta) + I_e r_p + I_m x_p \quad \dots(9'28)$$

here
and

R_p = equivalent resistance of the transformer referred to the primary side,
 X_p = equivalent reactance of the transformer referred to the primary side.

∴ Actual transformation (voltage) ratio $R = \frac{V_p}{V_s}$

$$= n + \frac{\frac{I_s}{n} [R_p \cos \Delta + X_p \sin \Delta] + I_e r_p + I_m x_p}{V_s} \quad \dots(9'29)$$

Eqn. 9'27 may be written as :

$$\begin{aligned} V_p &= n V_s + n I_s \cos \Delta \left(r_s + \frac{r_p}{n^2} \right) + n I_s \sin \Delta \left(x_s + \frac{x_p}{n^2} \right) + I_e r_p + I_m x_p \\ &= n V_s + n I_s \cos \Delta R_s + n I_s \sin \Delta X_s + I_e r_p + I_m x_p \\ &= n V_s + n I_s (R_s \cos \Delta + X_s \sin \Delta) + I_e r_p + I_m x_p \end{aligned} \quad \dots(9'30)$$

where

R_s = equivalent resistance of transformer referred to secondary side
 X_s = equivalent reactance of transformer referred to secondary side.

∴ Actual transformation (voltage) ratio

$$R = \frac{V_p}{V_s} = n + \frac{n I_s (R_s \cos \Delta + X_s \sin \Delta) + I_e r_p + I_m x_p}{V_s} \quad \dots(9'31)$$

Using Eqns. 9'28 and 9'30, the difference between actual transformation ratio and turns ratio is

$$R - n = \frac{\frac{I_s}{n} [R_p \cos \Delta + X_p \sin \Delta] + I_e r_p + I_m x_p}{V_s} \quad \dots(9'32)$$

$$= \frac{n I_s [R_s \cos \Delta + X_s \sin \Delta] + I_e r_p + I_m x_p}{V_s} \quad \dots(9'33)$$

Phase Angle. $\tan \theta = \frac{ab}{oa} = \frac{I_p x_p \cos \beta - I_p r_p \sin \beta + n I_s x_s \cos \Delta - n I_s r_s \sin \Delta}{n V_s + n I_s r_s \cos \Delta + n I_s x_p \sin \Delta + I_p r_p \cos \beta + I_p x_p \sin \beta}$

The terms in the denominator involving I_p and I_s are small and, therefore, they can be neglected as compared with $n V_s$.

$$\therefore \tan \theta = \frac{I_p x_p \cos \beta - I_p r_p \sin \beta + n I_s x_s \cos \Delta - n I_s r_s \sin \Delta}{n V_s}$$

$$= \frac{x_p \left(I_s + \frac{I_p}{n} \cos \Delta \right) - r_p \left(I_m + \frac{I_s}{n} \sin \Delta \right) + n I_s x_s \cos \Delta - n I_s r_s \sin \Delta}{n V_s}$$

$$= \frac{I_p \cos \Delta \left(\frac{x_p}{n} + n x_s \right) - I_s \sin \Delta \left(\frac{r_p}{n} + n r_s \right) + I_s x_p - I_m r_p}{n V_s}$$

$$= \frac{\frac{I_s \cos \Delta}{n} (x_p + n^2 x_s) - \frac{I_s \sin \Delta}{n} (r_p + n^2 r) + I_e x_p - I_m r_p}{n V_s}$$

$$= \frac{\frac{I_s \cos \Delta}{n} X_p - \frac{I_s \sin \Delta}{n} R_p + I_e x_p - I_m r_p}{n V_s} = \frac{\frac{I_s}{n} (X_p \cos \Delta - R_p \sin \Delta) + I_e x_p - I_m r_p}{n V_s}$$

Since θ is small, $\theta = \tan \theta$. $\therefore \theta = \frac{\frac{I_s}{n} (X_p \cos \Delta - R_p \sin \Delta) + I_e x_p - I_m r_p}{n V_s}$ rad. ... (9'34)

$$= \frac{I_s}{V_s} (X_s \cos \Delta - R_s \sin \Delta) + \frac{I_e x_p - I_m r_p}{n V_s} \text{ rad.} \quad \dots (9'35)$$

9'19. **Errors.** It is clear from above that like current transformers, the potential transformers also introduce errors into measurements.

Ratio (Voltage) Error.

The actual ratio of transformation varies with operating conditions and the error in secondary voltage may be defined as :

$$\text{Percentage ratio error} = \frac{K_n - R}{R} \times 100 \quad \dots (9'36)$$

Phase Angle Error

In an ideal voltage transformer there should not be any phase difference between primary voltage and the secondary voltage reversed. However, in an actual transformer there exists a phase difference between V_p and V_s reversed.

$$\text{Phase angle } \theta = \frac{\frac{I_s}{n} (X_p \cos \Delta - R_p \sin \Delta) + I_e x_p - I_m r_p}{n V_s} \text{ rad.} \quad \dots (9'37)$$

$$= \frac{I_s}{V_s} (X_s \cos \Delta - R_s \sin \Delta) + \frac{I_e x_p - I_m r_p}{n V_s} \quad \dots (9'38)$$

The phase angle is taken as +ve when secondary voltage reversed leads the primary voltage. The angle is -ve when secondary voltage reversed lags the primary voltage.

It should be clear that while measuring voltage, ratio error is only important while for power measurements both ratio and phase angle errors are involved.

9'21. **Reduction of Errors.** There has been improved accuracy of potential transformers with the advent of new materials. There are some modifications in design which lead to smaller total errors.

(ii) **Reduction of Magnetising and Loss Components.** From Eqn. 9'33 it is clear that the difference between actual ratio and the turns ratio is made up of two parts. One is dependent upon the secondary current and the other upon the two components of no load current. It should be understood that unlike in the case of current transformers and power transformers, the values of the two components of no load current are quite comparable with that of the load current. Hence a considerable improvement in the performance can be made by reducing the values of I_m and I_e . Such a reduction requires short magnetic paths, good quality core material, low flux density and suitable precautions in the assembly and interleaving of core.

(ii) **Reduction of Resistance and Leakage Reactance** Winding resistance can be minimized by using thick conductors and by adopting the smallest length of mean turn.

The leakage reactance of windings depends upon the magnitudes of primary and secondary leakage fluxes and, therefore, we should keep the two windings as close as possible. The spacing should be compatible with insulation requirements.

Actually we should keep the flux density in the core as high as feasible without approaching the saturation too closely. A high value of flux density results in lower cross-section of the core which means that the length of mean turn would be small and thus the resistance of the winding becomes smaller.

A high flux density means a high flux in the core and so the windings have lesser number of turns. A small number of turns naturally results in smaller leakage reactance of the windings.

It is generally agreed that the new grain oriented steels allow a flux density of 1.5 Wb/m^2 as compared with the older materials which allow about 1.2 Wb/m^2 .

(iii) **Turns Compensation.** At no load the actual ratio exceeds the turns ratio by an amount $(I_r p + I_m x_p) / V_s$ (See Eqn. 9.29). With an inductive or resistive load there is a further increase of ratio because of voltage drops in resistance and leakage reactance of the windings. If the turns ratio is equal to the nominal ratio, the actual ratio differs from the nominal ratio and thus there are errors.

The solution lies in making the turns ratio less than the nominal ratio. This can be done by either reducing the number of primary turns or increasing the number of secondary turns. This makes it possible to make the actual ratio of transformation equal to the nominal ratio for one particular value and type of burden. At the same time there is a general reduction in the ratio error over the entire working range of burden. The phase angle θ is practically unaffected by a small change in the turns ratio.

9.22. Construction of Potential Transformers. The design and construction of potential transformers are basically the same as those of power transformers but there are few major points of difference:

(i) Power transformers are designed keeping in view the efficiency, regulation and cost. The cost being reduced by using small core and conductor sizes. In designing a potential transformer, economy in material is not a big consideration and the transformers are designed to give desired performance i.e., constancy of ratio and smallness of phase angle. Compared to a power transformer, a potential transformer has larger core and conductor sizes. Economic designs may lead to large ratio and phase angle error which are very undesirable features.

(ii) The output of a voltage transformer is always small and the size is quite large. Therefore, the temperature rise is small and hence there are no thermal problems caused by overloads as in power transformers. In fact, the loading on a potential transformer is limited by accuracy considerations while in a power transformer the load limitation is on heating basis. Actually, the potential transformers are able to carry loads on a thermal basis many times their rated loads. These loads range from 2 to 3 times for low voltage potential transformers and upto 30 or more times for some high voltage transformers.

Core. The core may be of shell or core type of construction. Shell type construction is normally only used for low voltage transformers. Special precautions should be taken to assemble and interleave so that the effect of air gaps at the joints may be minimized.

Windings. The primary and secondary windings are coaxial to reduce the leakage reactance to minimum. In order to simplify the insulation problems, the low voltage winding (secondary) is put next to the core. The primary winding may be a single coil in low voltage transformers but must be subdivided into a number of short coils in high voltage transformers in order to reduce the insulation needed between coil layers.

Insulation. Cotton tape and varnished cambric are used as insulation for coil construction. Hard fibre separators are used between coils. At low voltages, the transformers are usually filled without compound but potential transformers for use at voltages above 7000 volt are oil-immersed. Dry type, porcelain insulated transformers have been developed in the continent for use upto 45 kV.

Bushings. Oil filled bushings are usually used for oil filled potential transformers as this minimizes the overall size of the transformer.

Two bushings are used when neither side of the line is at ground potential. Some potential transformers, connected from line to neutral of grounded neutral systems, have only one high voltage bushing.

It is pertinent to point out here that a current transformer needs only one bushing as leads from the two ends of the primary winding are brought through the same insulator since there is only a small voltage between them, thus saving the expense of another high voltage insulator.

A 2-winding single phase potential transformer is shown in Fig. 9'23.

9'23. High Voltage Potential Transformers. Conventional type potential transformers used for high voltages of 100 kV and above, are very large in size and costly to build because of insulation requirements. For example, a 110 kV potential transformer has an overall height of about 7.5 metre and weighs nearly 5 tonnes. This is a very unwieldy size and also the materials utilized in the transformer construction are very uneconomically utilized.

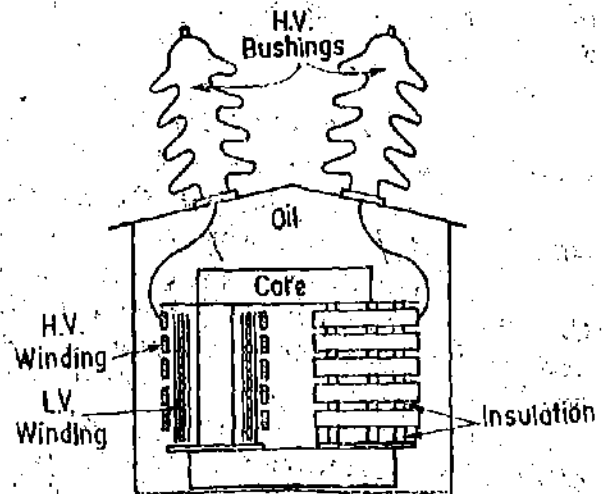

Fig. 9'23. Single phase potential transformer.

Recently there has been a development in the design and construction of P.T.s which has resulted in considerable reduction in size and cost of transformers. Two designs have been developed which eliminate the high voltage lead in bushings. The elimination of bushings reduces the size and cost of transformers. These designs are intended to measure line to ground voltages in a three phase system. The designs employ :

(i) **Insulated Casing.** The transformer is built entirely in an oil filled high voltage insulator. This results economy in space and material.

(ii) **Moulded Rubber Potential Transformer.** Recent developments in the synthetic rubber industry have introduced the moulded rubber potential transformer, replacing the insulating oil and porcelain bushings for some applications. This unit is less expensive than the conventional oil filled P.T., and since the bushings are made of moulded rubber, the difficulties caused due to porcelain breakage are eliminated.

(iii) **Cascaded Transformers.** In a cascaded arrangement, the voltage is divided among a number of transformers.

Suppose the voltage is divided among N transformers and, therefore, each transformer will take $1/N$ of total voltage. In this way each requires insulation corresponding to the lower voltage, with a consequent saving in space and material. The chief application of cascade arrangement is to increase voltage rating of dry type units. This arrangement is explained in details in chapter on High Voltage Measurements.

Protection. Potential transformers can be continuously operated at 1.2 times the rated voltage.

A short circuit on the secondary side of a potential transformer can lead to complete damage of the transformer. In order to protect the power system against short circuits in the potential transformers, fuses are used on the primary (high voltage) side. Fuses are used in the secondary side to protect the P.T. against faulty switching and defective earthing.

9'24. Capacitive Potential Transformers. At voltages above about 100 kV (phase) the conventional electro-magnetic type of potential transformer becomes expensive owing to insulation requirements. A less expensive alternative is capacitive voltage transformer.

This consists of a capacitance potential divider used in conjunction with a conventional auxiliary transformer (Fig. 9'24). The capacitance potential divider steps down the voltage to be measured (say to about 10 kV). The capacitance divider output voltage is further stepped down by the auxiliary transformer to the desired secondary voltage (say 110 V). The auxiliary transformer consists of an inductance L , which may consist wholly or partly of leakage inductance of the windings of auxiliary transformer. The value of this inductance L may be adjusted to equal

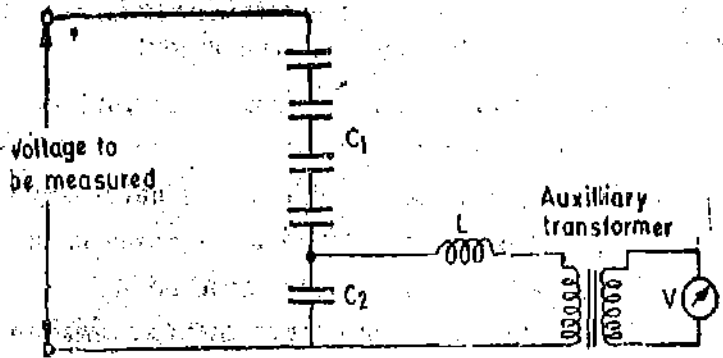

Fig. 9'24. Capacitive potential transformer.

$\frac{1}{\omega^2(C_1 + C_2)}$ so that the voltage drop due

to the current drained from the divider is largely compensated. Thus the overall voltage transformation ratio is independent of burden. The overall ratio is the product of the divider and transformer ratios. This has been explained in the chapter on High Voltage Measurements.

In practice, however, the compensation is not complete because of the losses in the inductance and also due to small changes in frequency which might occur. Nevertheless, the performance of capacitor voltage transformers is not much inferior to that of the electro-magnetic type of potential transformers and, provided the current in the primary of the auxiliary transformer does not exceed about 10% of that in the divider.

9'25. Characteristics of Potential Transformers

1. **Effect of Secondary Current or VA.** If we increase the secondary burden, the secondary current is increased, and, therefore, the primary current increases. Both primary and secondary voltage drops increase and thus for a given value of V_p , the value of V_s decreases and hence the actual ratio increases as the burden increases. The ratio error increases becoming more negative with increase in burden. This variation of ratio error is almost linear with change in burden.

With regard to phase angle, the voltage V_p is more advanced in phase because of increased voltage drops with increase in secondary burden. The phasor V_s reversed is retarded in phase owing to increase in secondary voltage drops. Thus with increase in burden, the phase angle between V_p and V_s reversed increases, becoming more negative.

2. **Effect of Power Factor of Secondary Burden.** If the power factor of secondary burden is reduced, angle Δ is increased. This makes current I_p to shift towards current I_0 (See Fig 9'21). The voltage V_p and V_s come more nearly into phase with E_p and E_s respectively since the voltage drops are almost constant. The result is an increase in V_p relative to E_p . But V_p is constant and, therefore, E_p reduces relative to V_p . The voltage V_s reduces relative to E_s . Therefore, the transformation ratio increases as the power factor of secondary burden reduces. Now with decrease in power factor V_s is advanced in phase and V_p retarded in phase, the phase angle (-ve) reduces with decrease in secondary power factor (lagging).

3. **Effect of Frequency.** For a constant voltage, the flux is inversely proportional to frequency. Increase in frequency reduces the flux and, therefore, I_m and I_0 are decreased and, therefore, the voltage ratio decreases. The decrease is not so much, as with increase in frequency the leakage reactance increases and, therefore, leakage reactance drops are increased giving an increase in ratio. Thus changes in voltage ratio because of change in frequency are dependent upon relative values of I_0 and leakage reactances since the effects produced by them oppose each other.

As regards phase angle error, both effects due to increase in frequency advance V_p and the increase in secondary reactance retards V_s and, therefore, the phase angle is increased as the frequency increases.

4. **Effect of Primary Voltage.** There is no wide variation of supply voltage to which the primary winding of the P.T. is connected. Therefore the study of variation of ratio and phase angle errors with supply voltage are of no importance.

Example 9.13. A potential transformer, ratio 1000/100 volt, has the following constants :

Primary resistance = 94.5 Ω , Secondary resistance = 0.86 Ω ,

Primary reactance = 66.2 Ω , Total equivalent reactance = 110 Ω ,

Magnetising current = 0.02 A at 0.4 power factor.

Calculate : (i) phase angle error at no load

(ii) load in VA at unity power factor at which the phase angle will be zero.

Solution :

No load power factor $\cos \alpha = 0.4$

$$\sin \alpha = \sqrt{(1)^2 - (0.4)^2} = 0.917$$

$\therefore I_e = I_0 \cos \alpha = 0.02 \times 0.4 = 0.008$ A.

$I_m = I_0 \sin \alpha = 0.02 \times 0.917 = 0.01834$ A.

Turns ratio $n = \frac{1000}{100} = 10$.

(i) From Equ. 9.34, phase angle $\theta = \frac{\frac{I_e}{n} (X_p \cos \Delta - R_p \sin \Delta) + I_e X_p - I_m R_p}{n V_s}$ rad.

At no load $I_s = 0$

$$\therefore \theta = \frac{I_e X_p - I_m R_p}{n V_s} = \frac{0.008 \times 66.2 - 0.01834 \times 94.5}{10 \times 1000} \text{ rad} = -4.1'$$

(iii) At unity power factor $\cos \Delta = 1$ and $\sin \Delta = 0$.

$$\theta = \frac{\frac{I_s}{n} X_p + I_e X_p - I_m R_p}{n V_s} \quad \text{For } \theta = 0, \quad \frac{I_s}{n} X_p + I_e X_p - I_m R_p = 0.$$

$$\text{or } I_s = \frac{n}{X_p} (I_m R_p - I_e X_p) = \frac{10}{100} (0.01834 \times 94.5 - 0.008 \times 66.2) = 0.109 \text{ A.}$$

Load $= I_s V_s = 0.109 \times 100 = 10.9$ VA.

Example 9.14. A potential transformer rated 6900/115 V, has 22,500 turns in the primary winding and 375 turns in the secondary winding. With 6900 V applied to the primary, and the secondary circuit open circuited, the primary current is 0.005 A lagging the voltage by 73.7°. With a particular burden connected to the secondary, the primary current is 0.0125 A, lagging the voltage by 53.1°.

Primary winding resistance = 1200 Ω , Primary winding reactance = 2000 Ω ,

Secondary winding resistance = 0.4 Ω , Secondary winding reactance = 0.7 Ω .

(i) Find the secondary current and terminal voltage, using the applied primary voltage $V_p = 6900 + j0$ as reference. Find the load burden also.

(ii) Find the actual transformation ratio and also the phase angle.

(iii) If the actual ratio is equal to the nominal ratio under above conditions, what change should be made in the primary turns ?

Solution : Nominal ratio $K_n = \frac{6900}{115} = 60$.

Primary turns $N_p=22500$. Secondary turns $N_s=375$
 Turns ratio $n = \frac{22500}{375} = 60$. No load current $I_0=0.005$ A.

No load p.f. $= \cos 73.7^\circ = 0.28$ and $\sin 73.7^\circ = 0.96$.

Primary current $I_p=0.0125$ A, Primary power factor $= \cos 53.1^\circ = 0.6$ and $\sin 53.1^\circ = 0.8$.

Now primary voltage V_p is taken as reference and, therefore, we can write :

$$V_p = 6900 + j0, I_p = 0.0125(0.6 - j0.8) = 0.0075 - j0.01$$

$$I_0 = 0.005(0.28 - j0.96) = 0.0014 - j0.0048.$$

[Phasor $\frac{I_s}{n}$ is the phasor difference of I_p and I_0]

$$\therefore \frac{I_s}{n} = (0.0075 - j0.01) - (0.0014 - j0.0048) = 0.0061 - j0.0052.$$

$$I_s \text{ (reversed)} = n \times \frac{I_s}{n} = 60(0.0061 - j0.0052) = 0.366 - j0.312.$$

or $I_s = -(0.366 - j0.312) = -0.366 + j0.312 \therefore$ Secondary current $I_s = 0.48$ A.

Primary induced voltage $E_p = V_p - I_p Z_p$

$$= 6900 - j0 - (0.0075 - j0.01)(1200 + j2000) = 6900 - j0 - (9 + j3) = 6891 - j3 \text{ V.}$$

$$\text{Secondary induced voltage } E_s \text{ (reversed)} = \frac{E_p}{n} = \frac{6891 - j3}{60} = 114.85 - j0.05 \text{ V.}$$

$$E_s = -(114.85 - j0.05) = -114.85 + j0.05 \text{ V.}$$

Secondary terminal voltage $V_s = E_s - I_s Z_s$

$$= -114.85 + j0.05 - (-0.366 + j0.312)(0.4 + j0.7) = -114.49 + j0.18 \text{ or } V_s = 114.49 \text{ V.}$$

Secondary burden $= V_s I_s = 114.49 \times 0.48 = 55 \text{ VA.}$

$$(ii) \text{ Actual ratio} = \frac{V_p}{V_s} = \frac{6900}{114.48} = 60.27.$$

$$V_s \text{ (reversed)} = -(-114.49 + j0.18) = 114.49 - j0.18 \text{ V.}$$

$$\text{Angle by which } V_s \text{ (reversed) lags } V_p = \tan^{-1} \frac{0.18}{114.49} \approx \frac{0.18}{114.49} \text{ rad.} = \frac{0.18}{114.49} \times \frac{180}{\pi} \\ = 0.90^\circ = 0.54'.$$

(iii) The solution to the problem lies in reducing the turns ratio (decreasing number of primary turns) so that the actual ratio equals the nominal ratio.

$$\text{New turns ratio} = \frac{60}{60.27} \times 60$$

$$\therefore \text{ New value of primary turns} = \frac{60}{60.27} \times 60 \times N_s = \frac{60}{60.27} \times 60 \times 375 = 22399.$$

$$\therefore \text{ Reduction in primary turns} = 22500 - 22399 = 101.$$

Here we are neglecting the change in voltage drops caused by change in turns ratio and hence the solution is only approximate.

9.26. Testing of Instrument Transformers

Methods for experimentally testing instrument transformers *i.e.*, finding their ratio and phase angle errors may be broadly classified into two groups :

(i) **Absolute Methods.** In these methods the transformer errors are determined in terms of constants-resistance, inductance and capacitance of the testing circuit.

(ii) **Comparison Method.** In these methods, the errors of the transformer under test are compared with those of a standard current transformer whose errors are known.

Each of these two test methods can be classified, according to measurement technique employed as :

(i) **Deflection Methods.** These methods use the deflections of suitable instruments like electro-dynamometer wattmeters for measuring quantities related to the phasors under consideration or to their deflection. The required ratio and phase angles are then found out from the magnitudes of deflection. These methods may be made direct reading in some cases.

(ii) **Null Methods.** These methods make use of a network in which the appropriate phasor quantities are balanced against one another. The ratio and phase angle errors are then found out from the impedance elements of the network. The method may be made direct reading in terms of calibrated scales on the adjustable elements in the network.

9.27. Current Transformer Testing

1. **Mutual Inductance Method.** This is an absolute method using null technique. The connections are shown in Fig. 9.25.

R_p and R_s are low resistance, non-inductive shunts. R_s is variable while R_p is fixed. R_s has a slide wire for fine adjustment of resistance. The voltage drop across resistance R_p is matched against voltage drop across R_s . A vibration galvanometer is put in the circuit to indicate the balance conditions. Assuming, for the moment that there is no phase difference between I_p and I_s the vibration galvanometer will indicate zero deflection if

$$I_p R_p = I_s R_s \quad \text{or} \quad \frac{I_p}{I_s} = \frac{R_s}{R_p}$$

Therefore, R_s and R_p should be so chosen that the ratio R_s/R_p is nearly equal to the nominal ratio of the current transformer.

Operation. Resistance R_s is adjusted to render the two voltage drops equal. In order to obtain zero deflection the magnitude and also the phase of the voltage drops should be same. Thus a mutual inductance M is put to compensate for phase difference between I_p and I_s as without any phase compensating device it will be impossible to obtain balance with resistance alone.

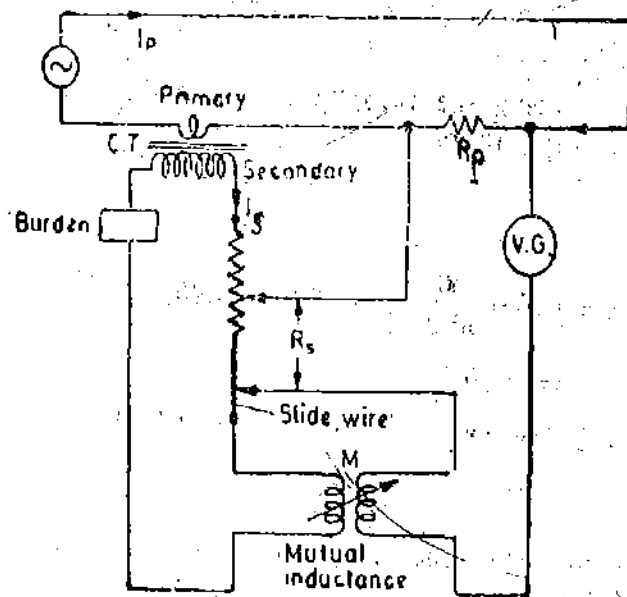

Fig. 9.25. Mutual inductance method.

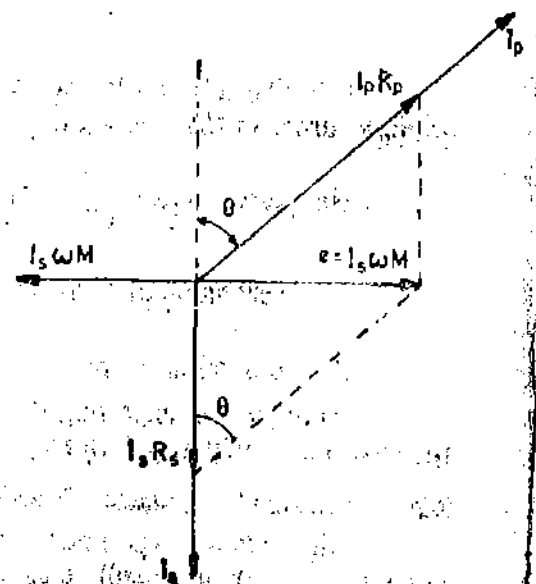

Fig. 9.26. Phasor diagram for mutual inductance method.

Theory. Fig. 9'26 represents the phasor diagram under balance conditions

$$\tan \theta = \frac{I_s \omega M}{I_s R_s} = \frac{\omega M}{R_s} \quad \text{and} \quad \cos \theta = \frac{I_s R_s}{I_p R_p}$$

From these relations we have, Phase angle $\theta = \frac{\omega M}{R_s}$ rad,

Actual ratio $R = \frac{I_p}{I_s} = \frac{R_s}{R_p \cos \theta} \approx \frac{R_s}{R_p}$ as θ is very small.

It should be noted that the secondary load circuit includes the resistance R_s , impedance of primary winding of mutual inductance and also the impedance marked burden. This must be taken into account while stating the burden at which the errors have been measured.

2. Silsbee's Method. Silsbee's method is a comparison method. There are two types of Silsbee's methods; deflectional and null. Only the deflectional method is described here.

The arrangement for this method is shown schematically in Fig. 9'27. Here the ratio and phase angle of the test transformer X are determined, in terms of that of a standard transformer S having the same nominal ratio.

The two transformers are connected with their primaries in series. An adjustable burden is put in the secondary circuit of the transformer under test.

An ammeter is included in the secondary circuit of the standard transformer so that the current may be set to the desired value. W_1 is a wattmeter whose current coil is connected to carry the secondary current of the standard transformer. The current coil of wattmeter W_2 carries a current ΔI which is the difference between the secondary currents of the standard and test transformers. The voltage circuits of the wattmeters (i.e., their pressure coils) are supplied in parallel from a phase shifting transformer at a constant voltage V .

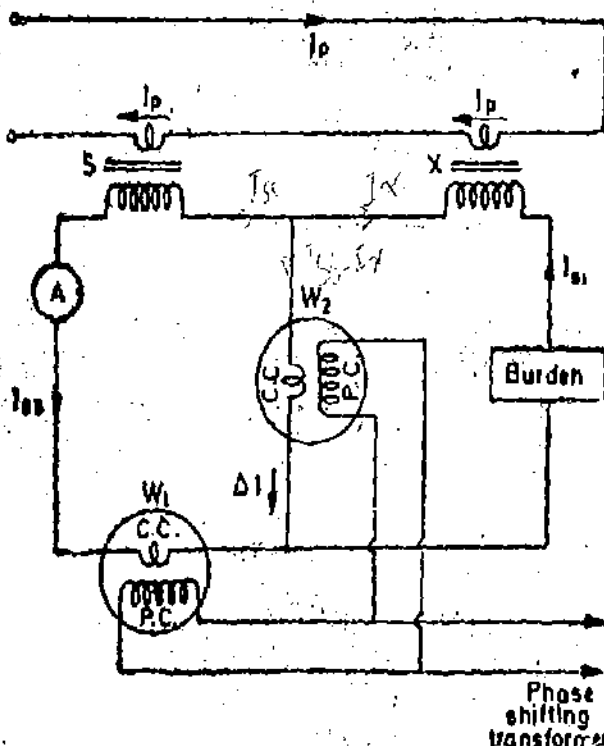

Fig. 9'27. Silsbee's deflectional method.

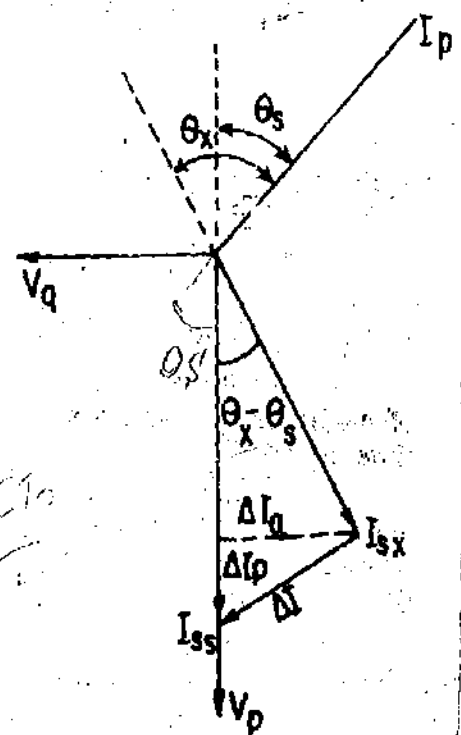

Fig. 9'28. Phasor diagram for Silsbee's method.

Operation and Theory. The phasor diagram is shown in Fig. 9'28.

1. The phase of the voltage is so adjusted that wattmeter W_1 reads zero. Under these

conditions, voltage V is in quadrature with current I_{sx} . The position of voltage phasor for this case is shown as V_q .

Reading of wattmeter W_1 , $W_{1q} = V_q I_{sx} \cos 90^\circ = 0$.

Reading of wattmeter W_2 , $W_{2q} = V_q \times$ component of current ΔI in phase with $V_q = V_q I_q = V_q I_{sx} \sin(\theta_x - \theta_s)$

where $\theta_x =$ phase angle of C.T. under test, $\theta_s =$ phase angle of standard C.T.

2. The phase of voltage V is shifted through 90° so that it occupies a position V_p and is in phase with I_{sx}

Reading of wattmeter W_1 , $W_{1p} = V_p I_{sx} \cos \theta \approx V_p I_{sx}$

Reading of wattmeter W_2 , $W_{2p} = V_p \times$ component of current ΔI in phase with $V_p = V_p \times I_p = V_p [I_{sx} - I_{sx} \cos(\theta_x - \theta_s)]$

If the voltage is kept same for both sets of readings, then $V = V_p = V_q$.

We have, $W_{1q} = V I_{sx} \sin(\theta_x - \theta_s)$, $W_{1p} = V I_{sx}$

$W_{2p} = V [I_{sx} - I_{sx} \cos(\theta_x - \theta_s)] = V I_{sx} - V I_{sx} \cos(\theta_x - \theta_s) = W_{1p} - V I_{sx} \cos(\theta_x - \theta_s)$

as $(\theta_x - \theta_s)$ is very small and, therefore, $\cos(\theta_x - \theta_s) = 1$.

For above, $V I_{sx} = W_{1p} - W_{2p}$.

Actual ratio of transformer under test $R_x = \frac{I_p}{I_{sx}}$

Actual ratio of standard transformer $R_s = \frac{I_p}{I_{sx}}$

$$\therefore \frac{R_x}{R_s} = \frac{I_{sx}}{I_{sx}} = \frac{V I_{sx}}{V I_{sx}} = \frac{W_{1p}}{W_{1p} - W_{2p}} = \frac{1}{1 - (W_{2p}/W_{1p})} \approx 1 + \frac{W_{2p}}{W_{1p}}$$

$$R_x = R_s \left(1 + \frac{W_{2p}}{W_{1p}} \right), \sin(\theta_x - \theta_s) = \frac{W_{2p}}{V I_{sx}}, (\cos \theta_x - \theta_s) = \frac{V I_{sx} - W_{2p}}{V I_{sx}} = \frac{W_{1p} - W_{2p}}{V I_{sx}}$$

$$\therefore \tan(\theta_x - \theta_s) = \frac{W_{2p}}{W_{1p} - W_{2p}} \quad \text{or} \quad (\theta_x - \theta_s) = \frac{W_{2p}}{W_{1p} - W_{2p}} \text{ rad.}$$

or phase angle of test transformer $\theta_x = \frac{W_{2p}}{W_{1p} - W_{2p}} + \theta_s$ rad.

$$\approx \frac{W_{2p}}{W_{1p}} + \theta_s \text{ rad.}$$

as W_{2p} is very small.

Thus if the ratio and phase angle errors of standard transformer are known, we can compute the errors of the test transformer.

W_2 must be a sensitive instrument. Its current coil may be designed for small values. It is normally designed to carry about 0.25 A for testing C.T.'s having a secondary current of 5A.

3. Arnold's Method. This is a comparison method involving null techniques.

This method is used for getting very accurate results. The errors of transformer under test X (Fig 9.29) are compared with those of a standard transformer S . In order to isolate the measuring circuit from the secondaries of C.T.s, a 5/5 current transformer T is used. This transformer has negligible errors.

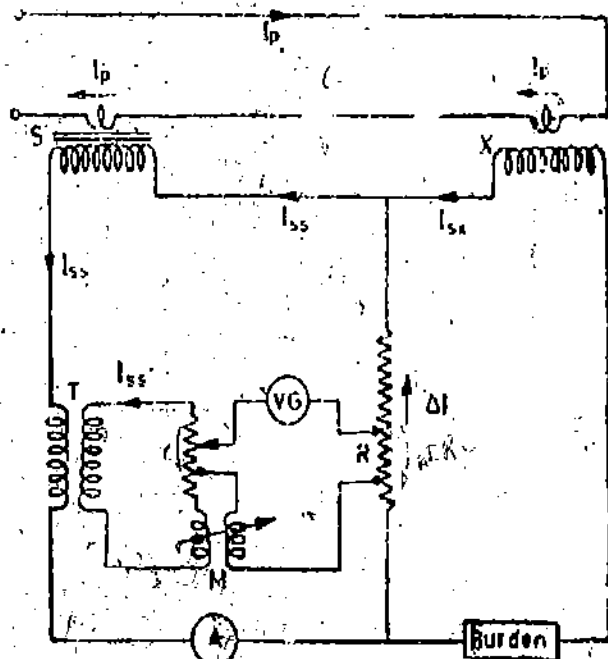

Fig. 9.29. Arnold's Method.

We use the same notations as we did in case of Silsbee's method. Balance is obtained when

$$\Delta I \times R + I_{ss} r - I'_{ss} j\omega M = 0$$

Now $\Delta I = I_{ss} - I_{sx}$ But $I_{ss} = -\frac{I_p}{R_s} (\cos \theta_s + j \sin \theta_s)$... (i)

$= -\frac{I_p}{R_s} (1 + j\theta_s)$ as θ_s is very small and $I_{sx} = -\frac{I_p}{R_x} (1 + j\theta_x)$ as θ_s is $\ll 1$
 $\cos \theta_s = 1$
 $\sin \theta_s = \theta_s$

Thus $I_{sx} = \frac{R_s}{R_x} [1 + j(\theta_x - \theta_s)] I_{ss}$ $\therefore \Delta I = I_{ss} \left[1 - \frac{R_s}{R_x} \{1 + j(\theta_x - \theta_s)\} \right]$

$I'_{ss} = I_{ss}$ as transformer T is 1 : 1 C.T.

Substituting these values of ΔI , and I_{ss} in (i)

$$I_{ss} \left[1 - \frac{R_s}{R_x} \{1 + j(\theta_x - \theta_s)\} \right] R + I_{ss} (j\omega M - r) = 0$$

Equating real quantities : $R \left(1 - \frac{R_s}{R_x} \right) = r$ $\therefore 1 - \frac{R_s}{R_x} = \frac{r}{R}$

Equating imaginary quantities : $\frac{R_s}{R_x} R(\theta_x - \theta_s) = \omega M$ $\therefore \theta_x - \theta_s = \frac{\omega M}{R} \cdot \frac{R_s}{R_x}$ rad.

But $R_x \approx R_s$ and, therefore, $\theta_x - \theta_s = \frac{\omega M}{R}$

\therefore Phase angle of transformer under test $\theta_x = \frac{\omega M}{R} + \theta_s$

Example 9.15 Two current transformers of the same nominal ratio 500/5 A, are tested by Silsbee's method. With the current in the secondary of the standard transformer adjusted at its rated value, the current in the middle conductor $\Delta I = 0.05 e^{-j126.9^\circ}$ A expressed with respect to current in the secondary of standard transformer as the reference. It is known that the standard transformer has a ratio correction factor (RCF) of 1.0015 and phase error +8'. Find RCF and phase angle error of transformer under test.

Solution : Nominal ratio = $\frac{500}{5} = 100$, $I_{ss} = 5$ A.

since I_{ss} is reference

$$I_{ss} = 5 + j0$$

$$\Delta I = 0.05 e^{-j126.9^\circ}$$

$$= 0.05 [\cos 126.9^\circ - j \sin 126.9^\circ]$$

$$= -0.03 - j0.04$$

Now, current in the secondary of test transformer

$$I_{sx} = I_{ss} - \Delta I = 5 + j0 - (-0.03 - j0.04)$$

$$= +5.03 + j0.04$$

or

$$I_{sx} \approx 5.03$$
 A.

Angle between I_{sx} and $I_{ss} = \frac{0.04}{5.03}$ rad. = 27.3'

Phase angle between I_{sx} reversed and $I_p = +27.3' + 8' = +35.3'$

Ratio correction factor RCF of standard transformer = 1.0015

\therefore Actual ratio of standard transformer

$$R_s = \text{RCF} \times \text{nominal ratio} = 1.0015 \times 100 = 100.15$$

Primary current $I_p = R_s \times I_{ss} = 100.15 \times 5 = 500.75$ A.

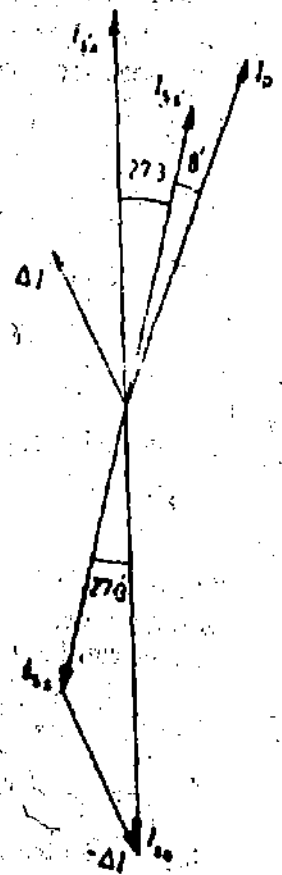

Fig. 9.30.

Actual ratio of transformer under test $R_a = \frac{I_p}{I_s} = \frac{500 \cdot 75}{5 \cdot 03} = 99 \cdot 55$.

Ratio correction factor of test transformer $RCF = \frac{\text{actual ratio}}{\text{nominal ratio}} = \frac{99 \cdot 55}{100} = 0 \cdot 9955$.

9'28. Potential Transformer Testing

1. Absolute null method. Fig. 9'31 shows the connections for testing a potential transformer using a resistance potential divider. The burden with which the transformer is to be tested is connected across the secondary winding, and the normal primary voltage, at normal frequency is applied to the primary winding. One end of the secondary is connected to one end of the primary winding. A non-inductive potential divider is connected across the primary winding. The lower part of the divider consists of a fixed resistor in series with a side-wire *S*, and the upper part consists of a shielded, high voltage resistor in series with the primary of a variable mutual inductor *M*. A capacitor *C* shunts a small part *r* of the upper part of the divider. *VG* is a vibration galvanometer. The resistances are chosen so that the nominal ratio of the test transformer is equal to R/R_1 .

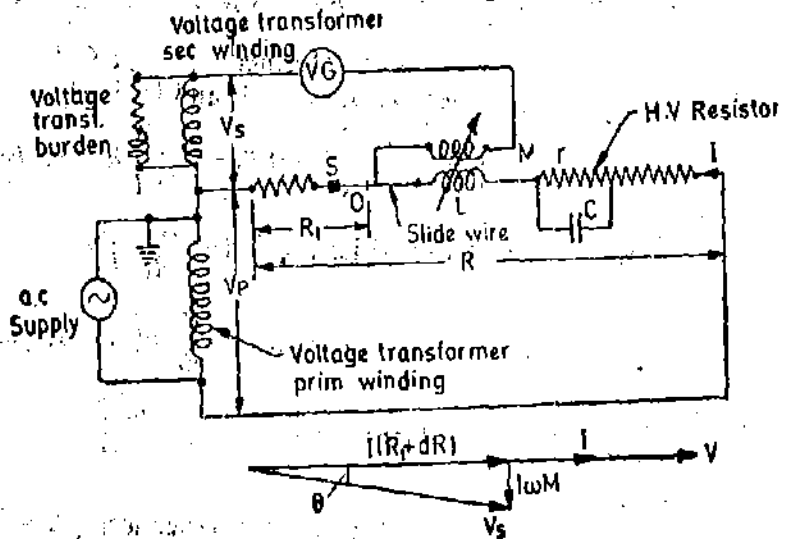

Fig. 9'31 Absolute method of testing potential transformers. The resistances are chosen so that the nominal ratio of the test transformer is equal to R/R_1 .

L is the primary inductance of the mutual inductor and will cause a phase error in the divider. The capacitor *C* compensates for this error in the following manner. The impedance of the whole divider is

$$Z = R - r + j\omega L + \frac{r}{1 + j\omega Cr}$$

$$= R - r + j\omega L + \frac{r}{1 + \omega^2 C^2 r^2} (1 - j\omega Cr) = R - r + \frac{r}{1 + \omega^2 C^2 r^2} + j\omega \left(L - \frac{Cr^2}{1 + \omega^2 C^2 r^2} \right)$$

By making $\frac{Cr^2}{1 + \omega^2 C^2 r^2} = L$, the divider is non-reactive at the operating frequency, which is usually 50 Hz, and the total impedance is then :

$$Z = R - r + \frac{r}{1 + \omega^2 C^2 r^2}$$

The term $\omega^2 C^2 r^2$ is normally small compared with unity and may be neglected, so that the impedance of the divider is equal to *R*. If this term is not negligible, the resistance of the upper part of the divider can be increased by a small amount to correct for it at the operating frequency.

In carrying out the test, the contact on the slide-wire and the mutual inductor are adjusted until the vibration galvanometer gives no deflection.

The phasor diagram corresponding to the balanced condition is shown in Fig. 9'31, in which $I = \frac{V_p}{R}$ is the current in the divider. The phase angle θ of the test transformer is small so that

$$V = I(R_1 + dR) = \frac{V_p}{R} (R_1 + dR)$$

and the transformer ratio is $\frac{V_p}{V_s} = \frac{R}{R_1 + dR}$

The ratio error = $\frac{\text{nominal ratio} - \text{actual ratio}}{\text{actual ratio}}$

$$= \frac{\frac{R}{R_1} - \frac{R}{R_1 + dR}}{\frac{R}{R_1 + dR}} = \frac{R}{R_1 + dR} \left[\frac{R}{R_1} - 1 \right] = \frac{dR}{R_1}$$

The slide-wire can therefore be calibrated directly in values of ratio error.

Phase Angle. From the phasor diagram, $\tan \theta_{\approx} \theta = \frac{\omega M}{R_1 + dR} \approx \frac{\omega M}{R_1}$

and the mutual inductor can be calibrated directly in terms of phase angle.

Special shielding arrangements have to be adopted for the high voltage resistor. If it is surrounded by a simple earthed shield, the capacitance currents flowing between the resistor and shield can cause serious errors. Such errors can be reduced by keeping the resistance of the divider as low as possible, and a value of 20 Ω/V is commonly adopted. The method of shielding is shown in chapter on high voltage testing (Chapter 17). The divider is broken into a number of sections, each enclosed in its own screen, and each screen is held at the midpotential of the section it encloses by means of an auxiliary divider. There is therefore a considerable reduction in the capacitance current from the divider to the shield.

It is not practical to construct resistance dividers suitable for voltage transformer testing at voltages much above 40 kV; the use of a capacitance divider is preferable at higher voltages.

Methods employing Capacitance Dividers. A wide variety of methods of testing voltage transformers with the aid of capacitance dividers have been used. Fig. 9.32 gives the connections of a method of testing PT, using capacitance voltage dividers.

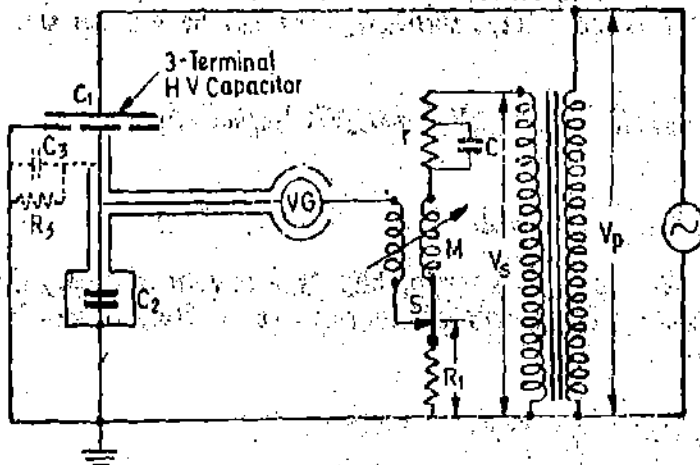

Fig. 9.32. Capacitance divider method of testing potential transformers.

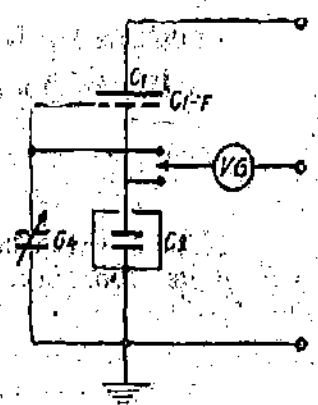

Fig. 9.33

C_1 is a high voltage, compressed-gas, three-terminal capacitor of value 10 pF, and C_2 is a high-quality mica capacitor having a very small power factor. One of the difficulties with capacitance dividers is the existence of the capacitance C_3 of the low-voltage electrode and guard ring of C_1 . This capacitance is often associated with a loss resistance R_3 , and it is therefore important that the value of the mica capacitor C_3 should be large so that $C_2 + C_3$ and R_3 have a negligible power factor. The

capacitance between the h.v. and l.v. electrodes of C_1 is loss-free; hence the phase error of the divider, which should be negligible, is determined by C_2 shunted by C_3 and R_3 . There is therefore a restriction on the minimum value of C_2 and on the minimum ratio of the divider. This difficulty can be overcome by the modification shown in Fig. 9.33, in which the guard ring is connected to earth through a capacitor C_4 which is adjusted so that $C_1/C_2 = C_1 - g/C_4$. The guard ring is then at the same potential as the low-voltage electrode.

A resistance divider having a ratio of 10/1 is connected across the secondary winding of the potential transformer under test. This divider incorporates a variable potential slide-wire S and mutual inductor M for ratio and phase-angle adjustment. It is similar to the arrangement used in the resistance divider equipment previously discussed. C and r are used to compensate for the primary inductance of the mutual inductor M , so that the divider is non-reactive at the test frequency. The slide-wire S , and the mutual inductor, can be calibrated to read ratio error and phase angle directly.

The adoption of a 10/1 ratio in the measuring resistance divider permits ratio errors of either sign to be measured. It has the added advantage that the ratio of the capacitance divider is 10 times the nominal ratio of the test transformer permitting the use of a large value of C_2 and thus minimizing the effect of C_3 and R_3 in the simple arrangement.

The compensation of the measuring resistance divider, and its zero setting, can be very easily checked by comparing it with a simple 10/1 ratio resistance divider.

Clothier and Medina Method. This method has been developed quite recently and uses a variable-tapping transformer for the measuring device. Fig. 9.34 is a simplified circuit diagram. C_1 and C_2 are three-terminal capacitors whose ratio is equal to the nominal ratio of the test transformer 1. The windings of transformer 1 are in series aiding. The errors in transformer 1 are balanced by means of transformer 2 whose ratio can be adjusted a little above or below unity by using decade switches to select the primary turns.

Phase-angle errors are balanced by supplying a current I_R through a high resistance R to the junction of C_1 and C_2 . I_R is in phase with the secondary voltage and therefore in quadrature with the current in C_2 . The value of I_R is adjusted by a switch on transformer 2 using a tuned electronic detector.

Theory. Since the detector voltage is zero at balance, the current in R is aV/R , where aV is the voltage across R with respect to earth and V is the voltage across C_2 . aV can have either sign.

At balance $I_1 = I_2 + I_R$.

$$I_1 = j\omega C_1 V_p, I_2 = j\omega C_2 V, \text{ and } I_R = aV/R \quad \therefore j\omega C_1 V_p = j\omega C_2 V [1 + a/j\omega C_2 R]$$

or

$$\frac{V_p}{V} = \frac{C_2}{C_1} \frac{V}{V} \left[1 - \frac{j}{\omega C_2 R} \right]$$

If the phase angle of the auxiliary transformer is negligible, and its voltage is very nearly equal to its turns ratio, then, if T_1 and T_2 are primary and secondary turns on Transformer 2, and if $T = T_2 - T_1$,

$$\frac{V_p}{V} = \frac{T_2}{T_1} = \frac{T_2}{T_2 - T} = \frac{1}{1 - T/T_2} = \frac{1}{1 - D}, \text{ where } D = T/T_2.$$

The phase angle $\theta = \tan^{-1} \frac{a}{\omega C_2 R}$ rad.

The ratio R_0 of the test transformer is

$$R_0 = \left| \frac{V_p}{V} \right| = \frac{C_2}{C_1} \frac{1}{1 - D} \sqrt{1 + \frac{a^2}{\omega^2 C_2^2 R^2}} = \frac{C_2}{C_1} \frac{1}{1 - D} \sqrt{1 + \theta^2}$$

If the ratio of the capacitance divider is adjusted so that C_2/C_1 is equal to the nominal ratio K_n of the transformer, then

$$\frac{R_n}{K_n} = \frac{1}{1-D} \sqrt{1+\theta_2} \approx 1 + D + D^2 + \frac{1}{2}\theta_2^2$$

In general, $\frac{R_n}{K_n} = 1 + D$ gives sufficient accuracy.

The accuracy of the method depends upon the auxiliary transformer 2. Its ratio is nearly unity, however, and in these conditions it is not difficult to construct a transformer having very small ratio error and phase angle

The guard rings which constitute the third terminals of capacitors C_1 and C_2 are not shown in Fig. 9'34 ; both are connected to earth.

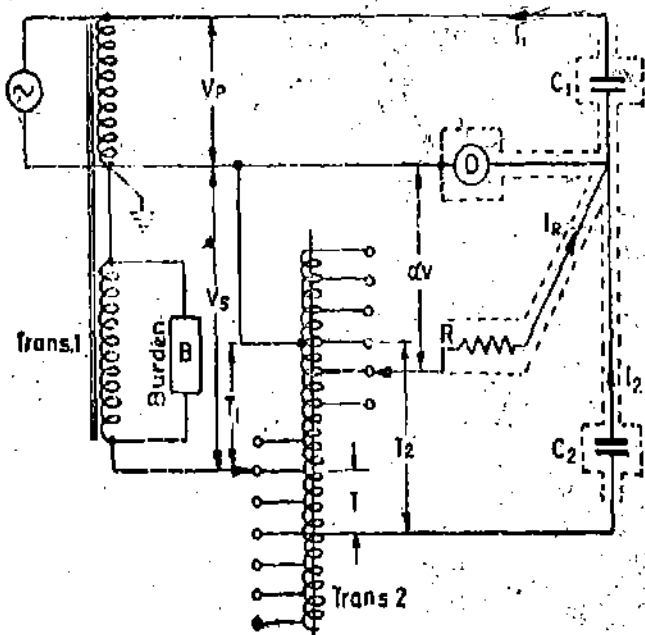

Fig. 9'34. Clothier and Medina absolute method of testing potential transformer.

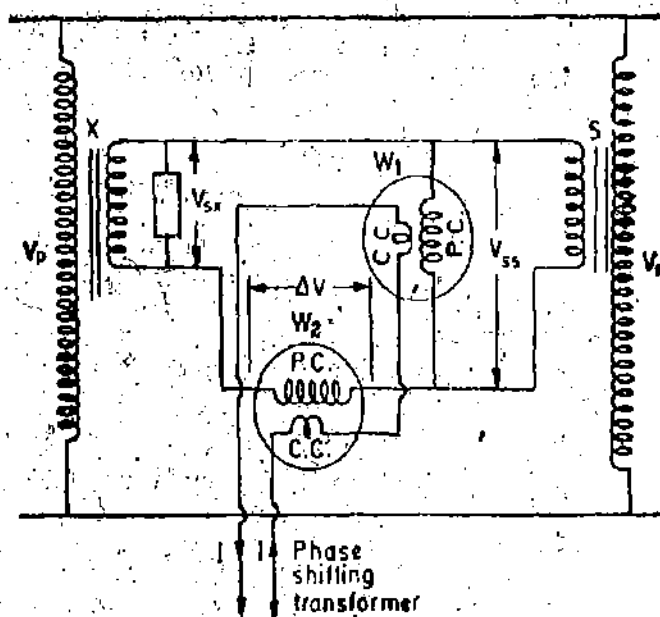

Fig. 9'35. Comparison method using wattmeters.

Comparison Methods

1. **Method Using Wattmeters.** This method is analogous to Silsbee's deflectional comparison method for current transformers. The arrangement is shown in Fig. '35. The ratio and phase angle errors of a test transformer are determined in terms of those of a standard transformer S having the same nominal ratio

The two transformers are connected with their primaries in parallel. A burden is put in the secondary circuit of test transformer. W_1 is a wattmeter whose potential coil is connected across the secondary of standard transformer. The pressure coil of wattmeter W_2 is so connected that a voltage ΔV which is the difference between secondary voltages of standard and test transformers, is impressed across it. The current coils of the two wattmeters are connected in series and are supplied from a phase shifting transformer. They carry a constant current I .

Operation and Theory

1. The phase of the current I is so adjusted that the wattmeter W_1 reads zero. Under these conditions current I is in quadrature with voltage V_{sx} . The position of current phasor for this case is shown in Fig. 9.36 as I_q .

Reading of wattmeter W_1 , $W_{1q} = V_{sx} I_q \cos 90^\circ = 0$.

Reading of wattmeter W_2

$$W_{2q} = \text{component of voltage } \Delta V \text{ in phase with } I_q \times I_q \\ = \Delta V_q I_q = V_{sx} \sin(\theta_x - \theta_s) \times I_q = V_{sx} I_q \sin(\theta_x - \theta_s).$$

2. The phase of current I is shifted through 90° so that it occupies a position I_p in phase with V_{sx} .

Reading of wattmeter W_1 , $W_{1p} = V_{sx} I_p \cos 0 = V_{sx} I_p$.

Reading of wattmeter W_2

$$W_{2p} = \text{component of voltage } \Delta V \text{ in phase with } I_p \times I_p \\ = \Delta V_p \times I_p = [V_{sx} - V_{sx} \cos(\theta_x - \theta_s)] I_p.$$

If the current is kept same for both the readings

$$I = I_p = I_q.$$

$$W_{2q} = V_{sx} I \sin(\theta_x - \theta_s), \quad W_{1p} = V_{sx} I$$

$$W_{2p} = [V_{sx} - V_{sx} \cos(\theta_x - \theta_s)] I$$

$$= V_{sx} I - V_{sx} I \cos(\theta_x - \theta_s) = W_{1p} - W_{2p}$$

as $(\theta_x - \theta_s)$ is very small. $\therefore V_{sx} I = W_{1p} - W_{2p}$.

$$\text{Actual ratio of test transformer } R_a = \frac{V_p}{V_{sx}}$$

$$\text{Actual ratio of standard transformer } R_s = \frac{V_p}{V_{sx}}$$

$$\therefore \frac{R_a}{R_s} = \frac{V_{sx}}{V_{sx}} = \frac{V_{sx} I}{V_{sx} I} = \frac{W_{1p}}{W_{1p} - W_{2p}} \approx 1 + \frac{W_{2p}}{W_{1p}}$$

$$\text{or ratio of transformer under test } R_a = R_s \left(1 + \frac{W_{2p}}{W_{1p}} \right).$$

$$\text{We have, } \sin(\theta_x - \theta_s) = \frac{W_{2q}}{V_{sx} I} \quad \text{and} \quad \cos(\theta_x - \theta_s) = \frac{V_{sx} I - W_{2p}}{V_{sx} I} = \frac{W_{1p} - W_{2p}}{V_{sx} I}$$

$$\text{From above } \tan(\theta_x - \theta_s) = \frac{W_{2q}}{W_{1p} - W_{2p}} \quad \text{or} \quad \theta_x - \theta_s \approx \frac{W_{2q}}{W_{1p} - W_{2p}} \text{ rad.}$$

$$\text{Phase angle of test transformer } \theta_x \approx \frac{W_{2q}}{W_{1p} - W_{2p}} + \theta_s \approx \frac{W_{2q}}{W_{1p}} + \theta_s \text{ rad.}$$

Wattmeter W_2 should have a very low voltage range since only a small voltage ΔV is impressed upon its pressure coil.

2. **Clothier and Medina Comparison Method.** A simplified diagram of the test circuit devised by Clothier and Medina is shown in Fig. 9.37. The primaries of the two transformers are connected in parallel and facilities are provided for fine adjustments of magnitude and phase of the secondary voltage of standard transformer until it equals that of the test transformer.

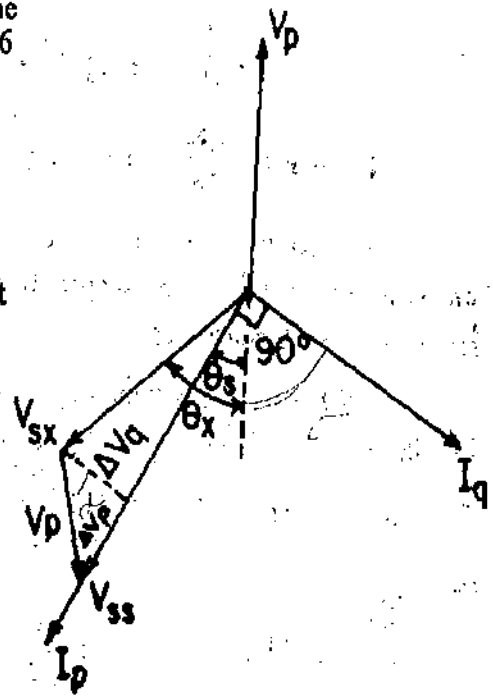

Fig. 9.36 Phasor diagram for Fig. 9.35.

Ratio balance is effected by adjustment of primary turns T_1 of an autotransformer connected to the secondary of the current transformer. The phase balance is done by adjustment of a resistance r through which a current flows, this current being in quadrature with the secondary voltage. The sign of the secondary voltage is selected by a reversing switch. Adjustments of resistance r can be made in steps of 1 in 10,000 in ratio and 0.1° in phase.

At balance :

$$\frac{R_x}{R_s} = \frac{T_1}{T_2} \text{ and } \theta_x = \theta_s \pm rC\omega$$

The circuit uses a tapped inductance L in parallel with resistance r , which ensures that the ratio and phase relations are completely independent. This can be achieved by making L equal to $2/(\omega^2 C)$ for negative and to $2/(3\omega^2 C)$ for positive phase angles.

This equipment is portable and uses an iron cored dynamometer instrument as a detector.

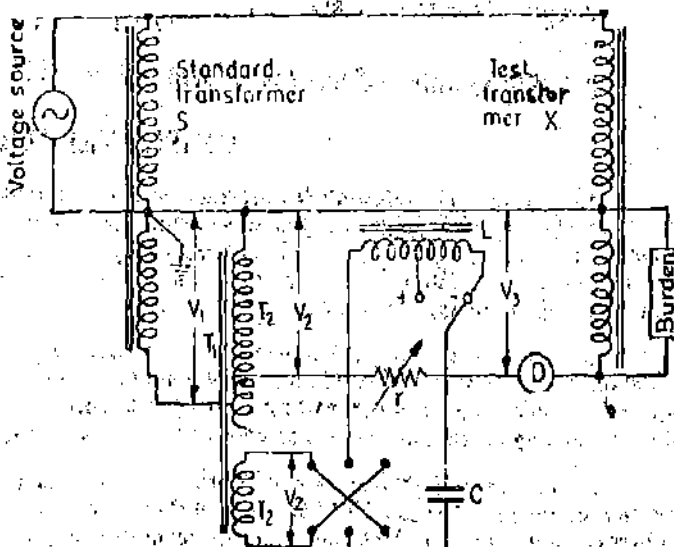

Fig. 9'37. Clothier and Medina comparison Method for testing potential transformers.

Example 9 16. An instrument potential transformer of nominal ratio 24,000/120 V is tested by comparison with a calibrated transformer of the same nominal ratio. The standard transformer is known to have an RCF of 0.9985 and a phase angle error of $-12'$. The secondaries are connected in opposition and the resultant voltage ΔV (terminal voltage of test transformer - terminal voltage of standard transformer) is $0.5 \angle 216.9^\circ$ volt with respect to secondary voltage of standard transformer when the transformers are fed from rated voltage supply. Compute the RCF and phase angle of test transformer.

Solution : V_{sx} = secondary voltage of test transformer,
 V_{ss} = secondary voltage of standard transformer,
 θ_x = phase angle of test transformer,
 and θ_s = phase angle of standard transformer.

Nominal ratio = $\frac{24000}{120} = 200.$

Actual ratio of standard transformer = RCF \times nominal ratio

$R_s = 0.9985 \times 200 = 199.7.$

$V_{ss} = \frac{V_p}{R_s} = \frac{24000}{199.7} = 120.18 \text{ V.}$

$V_{ss} = 120.18 + j 0$

$\Delta V = 0.5 \angle 216.9^\circ = 0.5 (\cos 216.9^\circ + j \sin 216.9^\circ) = -0.4 - j 0.3.$

It is given $V_{sx} = V_{ss} - \Delta V$

or $V_{sx} = \Delta V + V_{ss} = -0.4 - j 0.3 + 120.18 + j 0 = 119.78 - j 0.3.$

$\therefore V_{sx} \approx 119.78 \text{ V.}$

Actual ratio test transformer $R_x = \frac{V_p}{V_{sx}} = \frac{24000}{119.78} = 200.36.$

RCF of test transformer = $\frac{\text{actual ratio}}{\text{nominal ratio}} = \frac{200.36}{200} = 1.0018.$

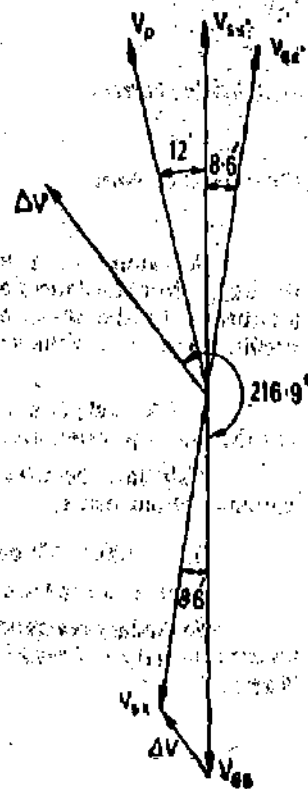

Fig. 9'38

$$\text{Angle between } V_{22} \text{ and } V_{21} = -\frac{0.3}{119.78} \times \frac{180}{\pi} \times 60 = -8.6'$$

\therefore Phase angle of test transformer $\theta_2 = -(12' + 8.6') = -20.6'$. (See Fig. 9.38).

UNSOLVED PROBLEMS

1. A ring-core current transformer with a nominal ratio of 500/5 and a bar primary has a secondary resistance of 0.5Ω and negligible secondary reactance. The resultant of magnetizing and iron loss components of the primary current associated with a full load secondary current of 5 A in a burden of 1.0Ω (non-inductive) is 3 A at a power factor of 0.4. Calculate the true ratio and the phase angle error of transformer on full load. Calculate also the total flux in the core assuming a frequency of 50 Hz
[Ans. 100.24; 0.314° ; 337×10^{-8} Wb]

2. An 8/1 current transformer has an accurate current ratio when the secondary is short circuited. The inductance of secondary is 60 mH and its resistance is 0.5Ω , and the frequency is 50 Hz. Estimate the current ratio and phase angle error when the instrument load resistance is 0.4Ω and inductance is 0.7 mH. Assume no iron loss and magnetizing current equal to 1 percent of primary current. The permeability remains constant. [Ans. 8.001; $0.2'$]

3. A current transformer with 5 primary turns has a secondary burden consisting of a resistance of 0.16Ω and an inductive resistance of 0.12Ω . When the primary current is 200 A, the magnetizing current is 1.5 A and the iron loss current is 0.4 A. Determine any expressions used, the number of secondary turns needed to make the current ratio 100/1 and also the phase angle under these conditions. [Ans. 497; $0.275'$]

4. A current transformer of nominal ratio 1000/5 A, is operating with total secondary impedance $0.4 + j0.3 \Omega$. At rated current the components of the primary current associated with the core-magnetizing and core loss effects are respectively 6 A and 1.5 A. The primary has 4 turns. Calculate the ratio error and phase angle at rated primary current if the secondary has (a) 800 turns (b) 795 turns. [Ans. (a) -0.48% ; $13'$, (b) $+0.14\%$; $13'$]

5. A bar type current transformer of toroidal construction requires 400 A to magnetize it, and 300 A to supply the iron loss for each volt per turn induced in the secondary winding and rated frequency. Across the secondary terminal is connected an impedance of 2Ω with a phase angle ϕ , and the resistance of secondary winding is 0.5Ω . The nominal ratio is 1000/5 A, and it is required to minimize both ratio and phase errors. Determine the necessary values of secondary turns and phase angle ϕ . [Ans. 194; $64^\circ 40'$]

6. The resistance and reactance of the secondary of a 500/5 A current transformer are 0.02Ω and 0.03Ω respectively and the transformers characteristics are given by:

<i>Emf.</i>	V	0.5	0.5	1.0	1.5	2.0
<i>Magnetizing current,</i>	A	0.9	1.5	2.5	3.2	4.0
<i>Core loss component,</i>	A	0.5	1.3	2.7	3.9	4.6

An ammeter, a wattmeter current coil and an induction relay are connected in series to the secondary winding. Their resistances are 0.8Ω , 0.10Ω , 0.14Ω and their reactances 0.09Ω , 0.07Ω and 0.08Ω respectively. If the current in the instruments is 4 A, calculate the ratio and phase angle error (a) when all the instruments are in circuit, (b) when only the wattmeter is in circuit. Calculate the load VA in each case.

[Ans. (a) 1.4% ; $1.25'$, 6.4 VA; (b) -0.601% ; $2.5'$, 1.96 VA]

7. A single phase potential transformer has a turns ratio of 3810/63. The nominal secondary voltage is 63 V and the total equivalent resistance and leakage reactance referred to the secondary side are 2Ω and 1Ω respectively.

Calculate the ratio and phase angle errors when the transformer is supplying a burden of $100 + j200 \Omega$. State the assumptions made. [Ans. -0.80% ; $-0.338'$]

8. A 500/100 V potential transformer has the following constants:

Primary resistance = 47.25Ω , Secondary resistance = 0.43Ω , Primary reactance = 33.1 .

Secondary reactance is negligible; no load primary current = 0.1 A at 0.6 p.f. Calculate (a) the no load angle between primary and reversed secondary voltages, (b) the value of secondary current at unity p.f. when the phase angle is zero. [Ans. (a) $12^\circ 20'$, (b) 0.0271 A]

Measurement of Power and Wattmeters

10.1. Power in D.C. Circuits. The power taken by a load from a d.c. supply is given by the product of readings of an ammeter and a voltmeter when connected in the circuit as shown in Fig. 10.1.

$$\text{Power } P = V \times I \text{ watt.}$$

It should be remembered that the ammeter and voltmeter require power for their operation and allowance must be made for this. Either of the two connections shown in Figs. 10.1 (a) and (b) may be used.

In Fig. 10.1 (a), the ammeter is connected between load and voltmeter. Therefore, the voltmeter not only indicates the voltage V_L across the load, but in addition voltage drop V_a across the

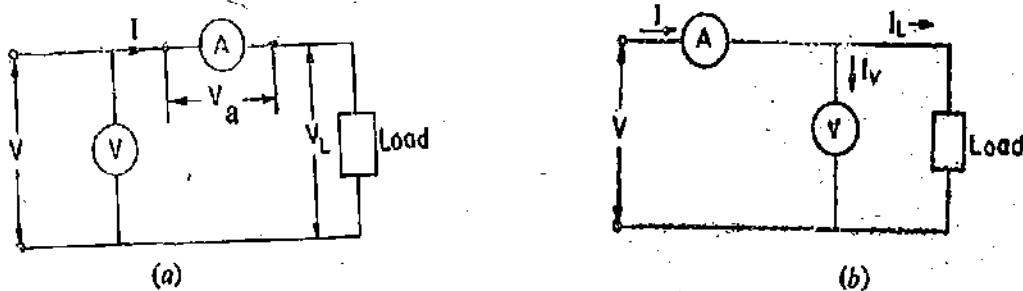

Fig. 10.1. Power measurement in D.C. circuits.

ammeter. If R_a is the resistance of the ammeter, voltage drop

$$V_a = I R_a$$

$$\text{Power consumed by load} = V_L I = (V - V_a) I = VI - V_a I = VI - I^2 R_a$$

$$= \text{power indicated by instruments} - \text{power loss in ammeter.}$$

In Fig. 10.1 (b), voltmeter is connected between load and ammeter. Therefore, ammeter not only indicates the current through the load but in addition current in the voltmeter also.

$$\text{Current through the voltmeter } I_v = \frac{V}{R_v} \text{ where } R_v = \text{resistance of voltmeter.}$$

$$\text{Power consumed by load} = V I_L = V(I - I_v) = V \left(I - \frac{V}{R_v} \right) = VI - \frac{V^2}{R_v}$$

$$= \text{power indicated by instruments} - \text{power loss in voltmeter.}$$

Thus in both the cases, the power indicated by the instruments is equal to the power consumed by the load plus the power consumed by the instrument nearest to the load terminals.

In order to obtain the true power, corrections must be applied for power loss in instruments. Under normal conditions the value of power loss in instruments is quite small as compared with the load power and, therefore, the error introduced on this account is small. However, when the output of the source to be measured is limited, the ammeter and voltmeter may load the circuit too heavily, causing a serious errors.

For a permanently wired installation, when power measurements are required, it is a distinct advantage to instal a wattmeter in place of voltmeter and ammeter. Wattmeter gives direct indication of power and there is no need of multiplying two readings as is the case when voltmeter and ammeter are used. The labour involved is reduced and the accuracy is also increased.

10.2. Power in A.C. circuits. In the case of alternating currents, the instantaneous power varies continuously as the current and voltage go through a cycle. However, we are not interested in the instantaneous power (except where transient conditions are being studied) but in its average value over a cycle. This is because the average power multiplied by time measures the transfer of energy over a time interval, if steady state conditions exist.

The instantaneous power is given by $p = vi$... (10.1)

where p, v, i are the instantaneous values of power, voltage and current respectively.

Thus, if both current and voltage waves are sinusoidal, the current lagging in phase by an angle ϕ , then :

$$v = V_m \sin \omega t \qquad i = I_m \sin (\omega t - \phi).$$

Therefore, the instantaneous power is given by

$$p = vi = V_m I_m \sin \omega t \sin (\omega t - \phi) \qquad \text{or writing } \theta = \omega t \text{ we have}$$

$$p = V_m I_m \sin \theta \sin (\theta - \phi) = V_m \frac{I_m}{2} [\cos \phi - \cos (2\theta - \phi)] \qquad \dots (10.2)$$

$$\text{Average power over a cycle is } P = \frac{V_m I_m}{2\pi} \int_0^{2\pi} \left[\frac{\cos \phi - \cos (2\theta - \phi)}{2} \right] d\theta = \frac{V_m I_m}{2} \cos \phi$$

$$P = VI \cos \phi \qquad \dots (10.3)$$

where V and I are rms values of voltage and current. $\cos \phi$ is the power factor of the load.

The fact the power factor ($\cos \phi$) is involved in the expression for power means that a wattmeter must be used for measurement of power in a.c. circuits instead of merely an ammeter and a voltmeter, since the later method takes no account of the power factor.

10.3. Electrodynamometer Wattmeters

These instruments are similar in design and construction to electro-dynamometer type ammeters and voltmeters described in Chapter 8. The two coils are connected in different circuits for measurement of power. The fixed coils or "field coils" are connected in series with the load and so carry the current in the circuit. The fixed coils, therefore, form the "current coil" of the wattmeter. The moving coil is connected across the voltage and therefore, carries a current proportional to the voltage. A high non-inductive resistance is connected in series with the moving coil to limit the current to a small value. Since the moving coil carries a current proportional to the voltage, it is called the "pressure coil" or "voltage coil" of the wattmeter.

10.4. Construction

1. Fixed Coils. The fixed coils carry the current of the circuit. They are divided into two halves. The reason for using fixed coils as current coils is that they can be made more massive and can be easily constructed to carry considerable current since they present no problem of getting the current in or out. The fixed coils are wound with heavy wire. This wire is stranded or laminated especially when carrying heavy currents in order to avoid eddy current losses in conductors. They are first varnished and baked to exclude moisture and clamped into place, thus forming a rigid solid assembly. In early wattmeters, the current coils were sometimes built to carry load currents of 100 A or more. But in such constructions, it is very difficult to avoid eddy currents. Also the use of heavy current leads introduces stray field errors. Because of these and other errors modern practice

usually limits the maximum current ranges of wattmeters to about 20 A. For power measurements involving large load currents, it is usually better to use a 5 A wattmeter in conjunction with a current transformer of suitable range.

In the case of precision wattmeters, the two halves of the fixed coil, which are connected in series for a basic measuring range, can be connected in parallel to increase the wattmeter current range to twice its original value. Shunts are not used for extension of current range since they are subject to temperature errors.

2. Moving Coil. The moving coil is mounted on a pivoted spindle and is entirely embraced by the fixed current coils. Spring control is used for the movement. Fig. 10.2 shows an electro-dynamometer type wattmeter. The use of moving coil as pressure coil is a natural consequence of design requirements. Since the current of the moving coil is carried by the instrument springs it is limited to values which can be carried by springs without appreciable heating. A series resistor is used in the voltage circuit, and the current limited to a small value, usually between 10 to 50 mA.

pivoted spindle and is entirely embraced

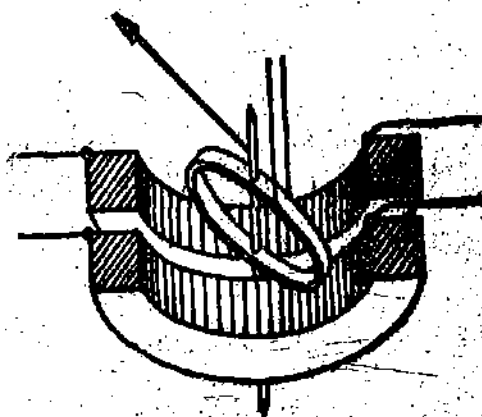

Fig. 10.2. Dynamometer wattmeter.

Both fixed and moving coils are air cored. The voltage rating of the wattmeter is limited to about 600 V by the power requirements of the voltage circuit since most of the power is absorbed by the resistance in series with the moving coil and considerable heat is generated. For higher voltages, the pressure coil circuit is designed for 110 V, and a potential transformer is used to step down the voltage.

a potential transformer is used to step

3. Control. Spring control is used for the instrument.

4. Damping. Air friction damping is used. The moving system carries a light aluminium vane which moves in a sector shaped box.

5. Scales and Pointers. They are equipped with mirror type scales and knife edge pointers to remove reading errors due to parallax.

10.5. Theory. The instantaneous torque of an electro-dynamometer instruments is given by

$$T_i = i_1 i_2 \frac{dM}{d\theta}$$

where i_1 and i_2 are instantaneous values of currents in two coils. Let V and I be the r.m.s. values of voltage and current being measured.

∴ Instantaneous value of voltage across the pressure coil circuit

$$v = \sqrt{2} V \sin \omega t.$$

If the pressure coil circuit has a very high resistance, it can be treated as purely resistive. Therefore, current i_p in the pressure coil is in phase with the voltage and its instantaneous value is :

$$i_p = \frac{v}{R_p} = \sqrt{2} \frac{V}{R_p} \sin \omega t = \sqrt{2} I_p \sin \omega t$$

here $I_p = \frac{V_p}{R_p}$ = rms value of current in pressure coil circuit.

and R_p = resistance of pressure coil circuit.

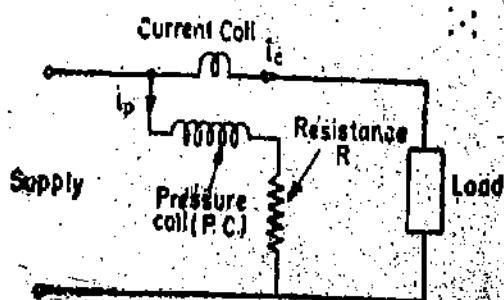

Fig. 10.3. Circuit of electro-dynamometer wattmeter.

If the current in the current coil lags the voltage in phase by an angle ϕ , instantaneous value of current through current coil is :

$$i_c = \sqrt{2} I \sin(\omega t - \phi)$$

$$\begin{aligned} \therefore \text{Instantaneous torque } T_t &= \sqrt{2} I_p \sin \omega t \times \sqrt{2} I \sin(\omega t - \phi) \frac{dM}{d\theta} \\ &= 2 I_p I \sin \omega t \sin(\omega t - \phi) \frac{dM}{d\theta} = I_p I \left[\cos \phi - \cos(2\omega t - \phi) \right] \frac{dM}{d\theta} \quad \dots(10'4) \end{aligned}$$

It is clear from above that there is a component of power which varies as twice the frequency of current and voltage (mark the term containing $2\omega t$).

Average deflecting torque

$$\begin{aligned} T_d &= \frac{1}{T} \int_0^T T_t d(\omega t) = \frac{1}{T} \int_0^T I_p I [\cos \phi - \cos(2\omega t - \phi)] \frac{dM}{d\theta} \cdot d(\omega t) \\ &= I_p I \cos \phi \frac{dM}{d\theta} \quad \dots(10'5) \end{aligned}$$

$$= \frac{VI}{R_p} \cos \phi \frac{dM}{d\theta} \quad \dots(10'6)$$

Controlling torque exerted by springs $T_c = K\theta$

where K = spring constant and θ = final steady deflection.

Since the moving system of the instrument cannot follow the rapid variations in torque (the torque has a double frequency, component), it will take up a position at which the average deflecting torque is equal to the restoring torque of the springs.

$$\therefore \text{At balance position } K\theta = I_p I \cos \phi \frac{dM}{d\theta}$$

$$\text{or deflection } \theta = \frac{I_p}{K} I \cos \phi \frac{dM}{d\theta} \quad \dots(10'7)$$

$$= \frac{VI \cos \phi}{R_p K} \frac{dM}{d\theta} \quad \dots(10'8)$$

$$= K_1 VI \cos \phi \frac{dM}{d\theta} \quad \dots(10'9)$$

$$= \left(K_1 \frac{dM}{d\theta} \right) P \quad \dots(10'10)$$

where P = power being measured = $VI \cos \phi$

$$\text{and } K_1 = \frac{1}{R_p K} \quad \dots(10'11)$$

10'6. Shape of Scale. It is clear from Eqn. 10'10, the deflection is directly proportional to the power being measured and the scale is essentially uniform over the range in which $(dM/d\theta)$ is constant. By suitable designs, the mutual inductance between fixed and moving coil can be made

to vary linearly with angle over a range of 40° to 50° on either side of zero mutual inductance position as shown in Fig. 10.4. If the position of zero mutual inductance is at the midscale, the scale will be uniform over 80° to 100° which covers almost the entire scale range.

10.7. Wattmeter Errors

1. Pressure Coil Inductance

- We have, r_p = resistance of pressure coil,
 L = inductance of pressure coil,
 R = resistance in series with pressure coil,
 R_p = total resistance of pressure coil circuit
 $= r_p + R$,
 V = voltage applied to pressure coil circuit,
 I = current in the current coil circuit,
 I_p = current in the pressure coil circuit,
 Z_p = impedance of pressure coil circuit
 $= \sqrt{(R + r_p)^2 + (\omega L)^2}$.

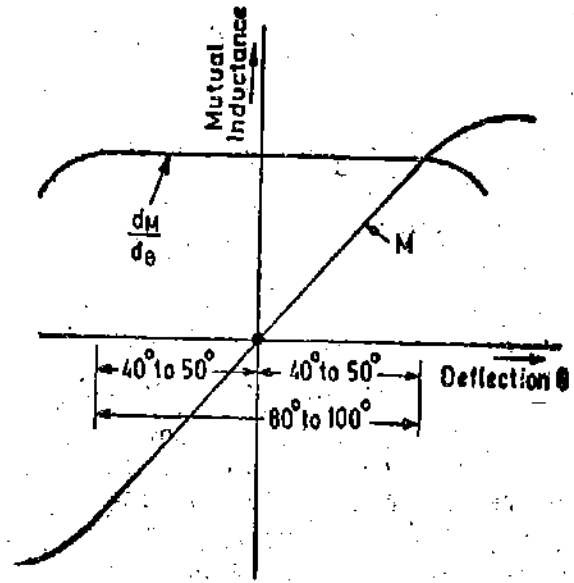

Fig. 10.4. Variation of mutual inductance with deflection.

It was implied in the discussions of the idealized wattmeter that the current in the pressure coil is in phase with the applied voltage. If the pressure coils of the wattmeter has an inductance the current in it will lag the voltage by an angle β where :

$$\beta = \tan^{-1} \frac{\omega L}{R_p} = \tan^{-1} \frac{\omega L}{r_p + R}$$

It will be seen from Fig. 10.5, that for lagging power factor, the angle between current in the current coil circuit and the current in the pressure coil circuit is less than ϕ , by which the load current lags the applied voltage. The angle between the pressure coil current and the current in the current coil is

$$\phi' = \phi - \beta$$

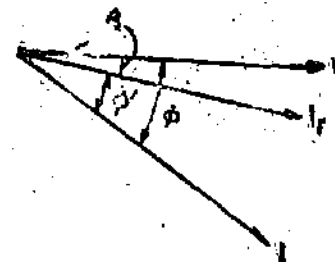

Fig. 10.5. Wattmeter phasor diagram for lagging p.f.

The actual wattmeter reading is :

$$= \frac{I_p I}{K} \cos \phi' \frac{dM}{d\theta} \quad (\text{See Eqn. 10.7})$$

$$= \frac{V}{Z_p K} I \cos (\phi - \beta) \frac{dM}{d\theta} \quad \text{Now } Z_p = \frac{R_p}{\cos \beta}$$

$$\therefore \text{Actual wattmeter reading} = \frac{VI \cos (\phi - \beta)}{K (R_p / \cos \beta)} \cdot \frac{dM}{d\theta} = \frac{VI}{K R_p} \cos \beta \cos (\phi - \beta) \frac{dM}{d\theta} \quad \dots(10.12)$$

In the absence of inductance $Z_p = R_p$ and $\beta = 0$ and therefore the wattmeter will read true power under these conditions.

$$\therefore \text{True power} = \frac{I_p I}{K} \cos \phi \frac{dM}{d\theta} = \frac{VI \cos \phi}{K R_p} \frac{dM}{d\theta} \quad \dots(10.13)$$

It is clear from the above expression that in the absence of inductance, the wattmeter read correctly at all power factors and frequencies.

$$\text{Ratio } \frac{\text{true power}}{\text{actual wattmeter reading}} = \frac{\frac{VI \cos \phi}{KR_p} \cdot \frac{dM}{d\theta}}{\frac{VI \cos (\phi - \beta)}{KR_p} \cos \beta \frac{dM}{d\theta}} = \frac{\cos \phi}{\cos \beta \cos (\phi - \beta)}$$

$$\therefore \text{ True power} = \frac{\cos \phi}{\cos \beta \cos (\phi - \beta)} \times \text{actual wattmeter reading.} \quad \dots(10'14)$$

Correction Factor

It is defined as a factor by which the actual wattmeter reading is multiplied to get the true power.

$$\therefore \text{ Correction factor} = \frac{\cos \phi}{\cos \beta \cos (\phi - \beta)} \text{ for lagging loads} \quad \dots(10'15)$$

It is clear from the phasor diagram (Fig. 10'5) that on lagging loads the wattmeter will read high, as the effect of the inductance of the pressure coil circuit is to bring the pressure coil current more nearly into phase with the load current than would be the case if this inductance were zero. Very serious errors may be introduced by pressure coil inductance at low power factors unless special precautions are taken.

The wattmeter will read low when the load power factor is leading as in that case the effect of pressure coil inductance is to increase the phase angle between load current and pressure coil current (See Fig. 10'6).

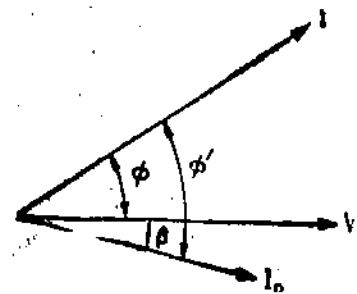

Fig. 10'6. Wattmeter phasor diagram for leading p.f.

$$\text{Correction factor for leading p.f.} = \frac{\cos \phi}{\cos \beta \cos (\phi + \beta)} \quad \dots(10'16)$$

Error

We will discuss only the lagging p.f. loads. The error in terms of instrument deflection is :

$$\text{Actual wattmeter reading} - \text{true power} = \left[1 - \frac{\cos \phi}{\cos \beta \cos (\phi - \beta)} \right] \times \text{actual wattmeter reading} \quad \dots(10'17)$$

$$= \left[1 - \frac{\cos \phi}{\cos (\phi - \beta)} \right] \times \text{actual wattmeter reading}$$

as β is very small, at most a few minutes and, therefore, $\cos \beta$ is nearly equal to unity.

$$\begin{aligned} \therefore \text{ Error} &= \left[1 - \frac{\cos \phi}{\cos \phi \cos \beta + \sin \phi \sin \beta} \right] \times \text{actual wattmeter reading} \\ &= \left[\frac{\sin \phi \sin \beta}{\cos \phi + \sin \phi \sin \beta} \right] \times \text{actual wattmeter reading} \\ &= \left[\frac{\sin \beta}{\cot \phi + \sin \beta} \right] \times \text{actual wattmeter reading} \quad \dots(10'18) \end{aligned}$$

$$\text{We can write Eqn. 10'14 as: } \frac{\text{true power}}{\text{actual wattmeter reading}} = \frac{\cos \phi}{\cos \beta \cos (\phi - \beta)}$$

$$= \frac{1 + \tan^2 \beta}{1 + \tan \phi \tan \beta}$$

Now β is very small and, therefore, $\tan^2 \beta \ll 1$.

$$\frac{\text{True power}}{\text{Actual wattmeter reading}} \approx \frac{1}{1 + \tan \phi \tan \beta}$$

or actual wattmeter reading = true power $(1 + \tan \phi \tan \beta)$... (10.19)

\therefore Error = actual wattmeter reading - true power = $\tan \phi \tan \beta \times$ true power ... (10.20)

Percentage error = $\frac{\text{wattmeter reading} - \text{true power}}{\text{true power}} \times 100 = \tan \phi \tan \beta \times 100$... (10.21)

We have, true power = $VI \cos \phi$ \therefore Error = $\tan \phi \tan \beta \times VI \cos \phi = VI \sin \phi \tan \beta$ (10.22)

It is clear from Eqn. 10.22 that the error is serious at low power factors.

Compensation for Inductance of Pressure Coil

Many wattmeters are compensated for errors caused by inductance of pressure coil by means of a capacitor connected in parallel with a portion of multiplier (series resistance) as shown in Fig. 10.7.

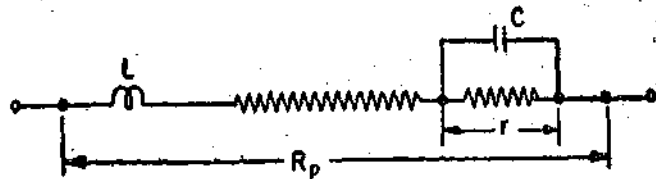

Fig. 10.7. Compensation for inductance of pressure coil circuit.

The total impedance of the circuit may be written as :

$$Z_p = (R_p - r) + j\omega L + \frac{r - j\omega Cr^2}{1 + \omega^2 C^2 r^2}$$

If the value of circuit constants are so chosen that for power frequencies $\omega^2 C^2 r^2 \ll 1$.

We have approximately, $Z_p \approx R_p - r + j\omega L + r - j\omega Cr^2 \approx R_p + j\omega(L - Cr^2)$.

If we make, $L = Cr^2$, then $Z_p \approx R_p$ and $\beta = 0$.

Thus the error caused by pressure coil inductance is almost completely eliminated.

This type of compensation is very slightly effected by change in frequency and can be used for frequencies at which $\omega^2 C^2 r^2 \ll 1$.

The frequency range over which the above compensation holds good is 10 kHz.

2. Pressure Coil Capacitance. The pressure coil circuit may possess capacitance in addition to inductance. This capacitance is mainly due to interturn capacitance of the series resistance. The effect capacitance is opposite to that produced by inductance, therefore, the wattmeter reads high on lagging power factor of the load.

The phase angle between pressure coil current and the applied voltage depends upon the reactance of the pressure coil circuit. The inductive reactance is normally greater than the capacitive reactance and, therefore, the phase angle varies with frequency, increasing with increase in frequency.

3. Error due to Mutual Inductance Effects. Errors are caused due to mutual inductance between current and pressure coils of the wattmeter. These errors are quite low at power frequency but they increase and become more important as the frequency is increased.

The effect of mutual inductance is to increase the phase angle for the connection in which the pressure coil is connected on the load side and to decrease the phase angle when the current coil is connected on the load side. This change in phase angle is $\tan^{-1} \left(\frac{\omega M}{R_p} \right)$.

If the self-capacitances are neglected, following expression may be used for computing power :

$$P_w = P + I^2 R_c + \left[\frac{L+M}{R_p} \right] \omega VI \sin \phi$$

where P_w is the wattmeter indication and P is the power in the load. This expression is used when the current coil is on the load side.

The problem of effects of mutual inductance is further complicated by the fact that it is not constant. We have seen in Art. 8'4 that the mutual inductance between the two coils varies as the moving coil (pressure coil) deflects. Thus the error caused by mutual inductance varies with relative positions of the two coils.

Instruments have been developed whose coil systems are so arranged that they are always in a zero position of mutual inductance and thus are free from errors caused by mutual inductance effects. These instruments also develop a maximum torque for every value of current (since M is always zero and thus $dM/d\theta$ is always maximum). The Drysdale Torsion-head wattmeter is an example of such an instrument.

4. Errors caused because of Connections. There are two alternate methods of connecting a wattmeter in a circuit. These are shown in Figs. 10'8 (a) and (b). Errors are introduced in the measurement owing to power loss in the current and the pressure coils.

In the connection of Fig. 10'8 (a), the pressure coil is connected on the supply side and, therefore, the voltage applied to the pressure coil is the voltage across the load plus the voltage drop across the current coil. Thus the wattmeter measures the power loss in its current coil in addition to the power consumed by load.

$$\begin{aligned} \text{Power indicated by wattmeter} &= \text{power consumed by load} + \text{power loss in current coil} \\ &= \text{power consumed by load} + I^2 R_c \end{aligned}$$

where

$$R_c = \text{resistance of current coil.}$$

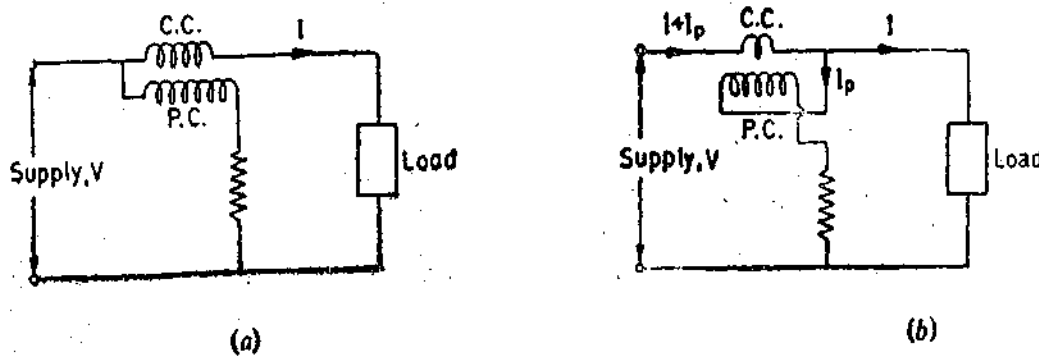

Fig. 10'8. Wattmeter Connections.

In connection of Fig. 10'8 (b), the current coil is on supply side and therefore it carries the pressure coil current plus the load current. Hence the wattmeter reads the power consumed in the load plus the power loss in the pressure coil.

$$\begin{aligned} \therefore \text{Power indicated by wattmeter} &= \text{power consumed by load} + \text{power loss in pressure coil} \\ &= \text{power consumed by load} + \frac{V^2}{R_p} \end{aligned}$$

If the load current is small, the voltage drop in the current coil is small, so that connection of Fig. 10'8 (a) introduces a very small error. On the other hand, if the load current is large, the value of pressure coil current is very small as compared with the load current and hence power loss

in pressure coil will be small as compared with the load power and, therefore, connection of Fig. 10'8 (b) is preferable.

It should be noted that in an uncompensated wattmeter, the reading of the wattmeter includes the power loss in the coil connected on the load side. The use of above connections for different applications [connection (a) for small current and (b) for large current] holds good only if the power loss in the instruments is to be neglected. However, if accuracy requires that the power loss in the instruments be taken into account, connection (b) is preferable. This is because for a constant voltage, the power loss V^2/R_p in the pressure coil circuit is constant and, therefore, the true power consumed by the load can be obtained by subtracting V^2/R_p from the wattmeter reading. The value of V^2/R_p can be calculated or observed directly by simply reading the wattmeter with load disconnected.

Compensation. The power taken by the pressure coil circuit is constant if the voltage is constant and becomes a smaller percentage of total as a larger amount of power is measured. However, in cases, where the load current is large and the power factor is small, connection (b) may result in large error since the total power measured is small. Hence in wattmeters which are designed for low power factor measurements, a compensating coil may be used in the instrument to compensate for the error caused by power loss in the pressure coil circuit. The arrangement using a compensating coil is shown in Fig. 10'9.

In connection 10 8 (b) the current coil carries a current of $I+I_p$ and produces a field corresponding to this current. The compensating coil is connected in series with the pressure coil circuit (Fig. 10'9) and is made as nearly as possible identical and coincident with the current coil. It is so connected that it opposes the field of the current coil. The compensating coil carries a current I_p and produces a field corresponding to this current. This field acts in opposition to the current coil field. Thus the resultant field is due to current I only. Hence the error caused by the pressure coil current flowing in the current coil is neutralized.

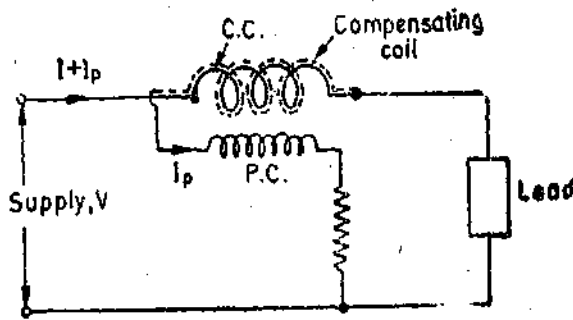

Fig. 10'9. Compensation for power loss in pressure coil circuit.

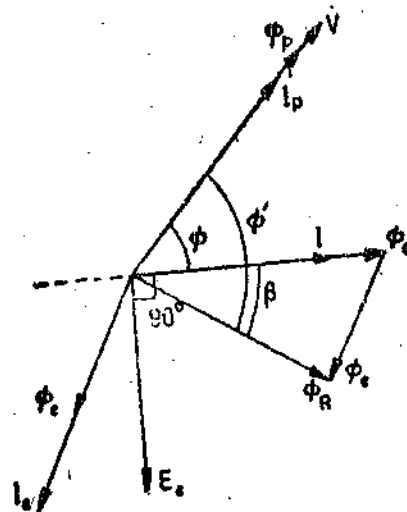

Fig. 10'10. Phasor diagram for illustrating the effect of eddy currents.

5. Eddy Current Errors. Eddy currents are induced in the solid metal parts and within the thickness of the conductors by alternating magnetic field of the current coil. These currents produce a field of their own and alter the magnitude and phase of the current coil field and thus cause errors.

Refer to the phasor diagram shown in Fig. 10'10.

The phase of eddy emf E_e is 90° behind the current coil flux Φ_c . The eddy current I_e lags eddy emf E_e by a small angle. I_e produces a flux Φ_e and therefore the resultant flux is Φ_R . It is clear from Fig. 10'10, that the resultant flux is less than the current coil flux Φ_c and lags it by a small angle.

Since the resultant flux lags the current coil flux, the phase angle between the fluxes Φ_p and

Φ_n , which produce the torque, is increased. As the magnitude of the field is decreased and the angle between fluxes is increased, the torque produced is decreased for lagging power factors.

This error is similar in principle to the error caused by the inductance of pressure coil except that the sign of error is opposite. From Fig. 10'10, it is clear that the wattmeter will read low for lagging power factors and high for leading power factors.

The error caused by eddy currents is not easily calculable and may be serious if the metal parts are not well removed from the current coil. In fact solid metal parts should be avoided as far as possible. Stranded conductors should be used for the current coil if the current carried is large. This reduces the eddy currents induced within the thickness of the coil.

6. Stray Magnetic Field Errors. The electro-dynamometer wattmeter has a relatively weak operating field and, therefore, it is particularly effected by stray magnetic fields resulting in the serious errors. Hence these instruments should be shielded against effects of stray magnetic fields.

Laminated iron shields are used in portable laboratory instruments while steel cases are sometimes provided to shield the switch-board instruments. Precision type of wattmeters are not provided with shields in order to keep down errors caused by eddy currents and to avoid the small d.c. errors which may be caused by permanent magnetism of the shield. Such wattmeters use an astatic system as shown in Fig. 8'43.

7. Errors Caused by Vibration of Moving System. This error is found occasionally on alternating currents. The torque on the moving system varies cyclically with a frequency which is twice that of the voltage (See Eqn. 10'4). If the pointer, spring or some other part of the moving system has a natural frequency which is in approximate resonance with the frequency of torque pulsation, the moving system would vibrate with a considerable amplitude. These vibrations not only make the position of the pointer difficult to read but also the mean position of the pointer may be displaced from that corresponding to the average value of power. These vibrations are avoided by designing the instruments in such a way that the natural frequency of the moving system is very much away from twice the frequency of the system on which the wattmeter is intended to be used.

8. Temperature Errors. The indication of a wattmeter is effected by changes in room temperature. This is because any change in room temperature changes the resistance of the pressure coil and the stiffness of the springs. These effects are opposite in nature and would nearly neutralize each other, if the pressure coil circuit were composed of copper and of a resistance alloy having a negligible temperature co-efficient, in the ratio of 1 : 10.

Example 10'1. In a dynamometer wattmeter the moving coil has 500 turns of mean diameter 30 mm. Estimate the torque if the axes of the field and moving coils are at (a) 60° (b) 90° when the density in the field coils is 15×10^{-3} Wb/m², the current in moving coil is 0'05 A and the power factor is 0'866.

Solution. Let us take the position of moving coil when its axis is coincident with that of fixed coil as reference. Let θ be the deflection from the reference position, i.e., θ be the angle between axes of two coils

Flux linking with moving coil = area \times component of flux density perpendicular to area

$$= \frac{\pi}{4} D^2 \times B \times \cos \theta,$$

where

D = mean diameter of pressure coil.

$$\text{Flux linkages of moving coil} = N \times \frac{\pi}{4} D^2 \times B \cos \theta = \frac{\pi}{4} ND^2 B \cos \theta.$$

$$\text{Mutual inductance } M = \frac{\text{flux linkages of moving coil}}{\text{current of fixed coil}} = \frac{\pi}{4I} ND^2 B \cos \theta = M_{\max} \cos \theta$$

where

$$M_{\max} = \text{maximum mutual inductance} = \frac{\pi}{4I} ND^2 B.$$

$$\text{Rate of change of flux linkages } \frac{dM}{d\theta} = \frac{\pi}{4I} ND^2 B \sin \theta = M_{max} \sin \theta.$$

$$\text{From Eqn. 10'6, torque exerted } T_d = \frac{V}{R_p} I \cos \phi \frac{dM}{d\theta} = \left(\frac{VI \cos \phi}{R_p} \right) M_{max} \sin \theta$$

$$= (I_p I \cos \phi) M_{max} \sin \theta = I_p I \times \frac{\pi}{4I} ND^2 B \sin \theta \cos \phi = \frac{\pi}{4} ND^2 B I_p \cos \phi \sin \theta.$$

We have $B = 15 \times 10^{-3} \text{ Wb/m}^2$; $I_p = 0.05 \text{ A}$; $N = 500$; $D = 30 \times 10^{-3} \text{ m}$; $\cos \phi = 0.866$.

(a) For $\theta = 60^\circ$, $\sin \theta = 0.866$.

$$\therefore \text{Deflecting torque } T_d = \frac{\pi}{4} \times 500 \times (30 \times 10^{-3})^2 \times 15 \times 10^{-3} \times 0.05 \times 0.866 \times 0.866$$

$$= 199 \times 10^{-6} \text{ Nm}$$

(b) when $\theta = 90^\circ$, $\sin \theta = 1$

$$\therefore T_d = \frac{\pi}{4} \times 500 \times (3 \times 10^{-2})^2 \times 15 \times 10^{-3} \times 0.05 \times 0.866 \times 1 = 230 \times 10^{-6} \text{ Nm.}$$

Example 10'2. An uncompensated spring controlled dynamometer wattmeter reads 250 W with d.c. currents of 1 A and 0.05 A in its current and potential coils respectively. Calculate what this wattmeter will read when the current coil current is $10 \sin(377t + 15^\circ) + 5 \sin(1131t)$ ampere and the potential coil voltage is $500 \cos(377t - 30^\circ) + 800 \sin(754t + 45^\circ)$ volt. Calculate also the resistance of the potential coil circuit assuming it to be purely resistive.

Solution: With d.c. Power $P = 250 \text{ W}$. Current coil current $I = 1 \text{ A}$.

$$\text{Voltage across pressure coil circuit } V = \frac{250}{1} = 250 \text{ V.}$$

$$\text{Pressure coil current } I_p = 0.05 \text{ A. } \therefore \text{Pressure coil circuit resistance } R_p = \frac{250}{0.05} = 5000 \Omega.$$

With a.c. Instantaneous current $i = 10 \sin(377t + 15^\circ) + 5 \sin(1131t)$

Putting $377t = \theta$, we have $i = 10 \sin(\theta + 15^\circ) + 5 \sin(3\theta)$.

$$\text{Instantaneous voltage } v = 500 \cos(377t - 30^\circ) + 800 \sin(754t + 45^\circ)$$

$$= 500 \cos(\theta - 30^\circ) + 800 \sin(2\theta + 45^\circ)$$

Instantaneous power $p = vi$

$$= 500 \times 10 \sin(\theta + 15^\circ) \cos(\theta - 30^\circ) + 500 \times 5 \sin(3\theta) \cos(\theta - 30^\circ)$$

$$+ 800 \times 10 \sin(\theta + 15^\circ) \sin(2\theta + 45^\circ) + 800 \times 5 \sin(3\theta) \sin(2\theta + 45^\circ).$$

$$\text{Average power over a cycle } P = \frac{1}{2\pi} \int_0^{2\pi} vi \, d\theta.$$

We have the following identities :

$$(i) \frac{1}{2\pi} \int_0^{2\pi} A \sin(\theta + \alpha) \cdot B \sin(\theta + \beta) \, d\theta = \frac{1}{2} AB \cos(\alpha - \beta).$$

$$(ii) \frac{1}{2\pi} \int_0^{2\pi} A \sin(\theta + \alpha) \cdot B \cos(\theta + \beta) d\theta = \frac{1}{2} A B \sin(\alpha - \beta).$$

$$(iii) \frac{1}{2\pi} \int_0^{2\pi} A \sin(m\theta + \alpha) \cdot B \sin(n\theta + \beta) d\theta = 0$$

$$\text{and } (iv) \frac{1}{2\pi} \int_0^{2\pi} A \sin(m\theta + \alpha) \cdot B \cos(n\theta + \beta) d\theta = 0.$$

$$\text{Therefore, } \frac{1}{2\pi} \int_0^{2\pi} 500 \times 10 \sin(\theta + 15^\circ) \cos(\theta - 30^\circ) d\theta = \frac{1}{2} \times 500 \times 10 \sin 45^\circ = 1760$$

$$\text{Now } \frac{1}{2\pi} \int_0^{2\pi} 500 \times 5 \sin(3\theta) \cos(\theta - 30^\circ) d\theta = 0; \quad \frac{1}{2\pi} \int_0^{2\pi} 800 \times 10 \sin(\theta + 15^\circ) \sin(2\theta + 45^\circ) d\theta = 0;$$

$$\text{and } \frac{1}{2\pi} \int_0^{2\pi} 800 \times 5 \sin(3\theta) \sin(2\theta + 45^\circ) d\theta = 0.$$

Hence average power $P = 1760$ W.

Example 10.3. A wattmeter has a current coil of 0.1Ω resistance and a pressure coil of 6500Ω resistance. Calculate the percentage errors, due to resistance only with each of the methods of connection, when reading the input to an apparatus which takes :

(a) 12 A at 250 V with unity power factor, and (b) 12 A at 250 V and 0.4 power factor.

Solution : (a) Power = $VI \cos \phi = 250 \times 12 \times 1 = 3000$ W.

The two possible ways in which the pressure coil can be connected are shown in Figs. 10.8 (a) and 10.8 (b).

For connection of Fig. 10.8 (a), the error is caused by power lost in the current coil.

Power loss in current coil = $I^2 R_c = (12)^2 \times 0.1 = 14.4$ W.

$$\therefore \text{Error} = \frac{14.4}{3000} \times 100 = 0.48\%.$$

For connection of Fig. 10.8 (b), error is caused by power lost in pressure coil.

$$\text{Power loss in pressure coil} = \frac{V^2}{R_p} = \frac{(250)^2}{6500} = 9.6 \text{ W. } \therefore \text{Error} = \frac{9.6}{3000} \times 100 = 0.32\%$$

(b) Power = $250 \times 12 \times 0.4 = 1200$ W. For connection of Fig. 10.8 (a)

$$\text{Error} = \frac{14.4}{1200} \times 100 = 1.2\%.$$

For connection of Fig. 10.8 (b) error = $\frac{9.6}{1200} \times 100 = 0.8\%$.

Example 10.4. A wattmeter has a current coil of 0.03Ω resistance and a pressure coil of 6000Ω resistance. Calculate the percentage error if the wattmeter is so connected that :

(i) the current coil is on the load side, (ii) the pressure coil is on the load side

(a) if the load takes 20 A at a voltage of 220 V and 0.6 power factor in each case. (b) What load current would give equal errors with the two connections ?

Solution : (a) Power consumed by load = $220 \times 20 \times 0.6 = 2640$ W.

(i) The wattmeter measures the loss in the current coil for this connection.

$$\text{Loss in current coil} = I^2 R_c = (20)^2 \times 0.03 = 12 \text{ W. } \therefore \text{Error} = \frac{12}{2640} \times 100 = 0.45 \%$$

(ii) The wattmeter measures the loss in the pressure coil circuit for this connection.

$$\text{Loss in pressure coil circuit} = \frac{V^2}{R_p} = \frac{(220)^2}{6000} = 8.06 \text{ W. } \text{Error} = \frac{8.06}{2640} \times 100 = 0.31 \%$$

(b) For equal error for the two connections

$$I^2 R_c = \frac{V^2}{R_p} \quad \text{or} \quad I^2 = \frac{V^2}{R_c R_p} = \frac{(220)^2}{0.03 \times 6000} \quad \therefore I = 16.5 \text{ A.}$$

Example 10.5. A wattmeter is rated at 10 A and 25 V. The current coil has a resistance of 0.06Ω and a reactance of 0.02Ω . The potential coil circuit may be assumed to be purely resistive having a resistance of 6250Ω . Find the error due to the two different connections shown in Fig. 10.8. The load is 10 A at a power factor of 0.174 lagging. The voltage across the load is 25 V.

Solution : Power = $VI \cos \phi = 25 \times 10 \times 0.174 = 43.5$ W. When the current coil is on the load side the voltage drops in its resistance and reactance of current coil are :

$$IR_c = 10 \times 0.06 = 0.6 \text{ V, and } IX_c = 10 \times 0.02 = 0.2 \text{ V.}$$

$$\cos \phi = 0.174 \text{ or } \phi = 80^\circ$$

The voltage across pressure coil

$$V_p = 25 + 0.6 \cos 80^\circ + 0.2 \sin 80^\circ - j(0.6 \sin 80^\circ + 0.2 \cos 80^\circ) = 25.3 \angle -1.4^\circ \text{ V.}$$

$$\therefore \text{Power indicated by wattmeter} = 25.3 \times 10 \times \cos(80^\circ - 1.4^\circ) = 50 \text{ W.}$$

$$\text{Error} = \frac{50 - 43.5}{43.5} \times 100 = 14.94 \%$$

When pressure coil is used on the load side as shown in Fig. 10.8 (b),

$$\text{Power lost in pressure coil circuit} = \frac{(25)^2}{6250} = 0.1 \text{ W. } \text{Error} = \frac{0.1}{43.5} \times 100 = 0.23 \%$$

The error in the case of connection [Fig. 10.8 (b)] is negligible and this connection should be preferred.

Example 10.6. A dynamometer wattmeter is used to measure the power factor of a $20 \mu\text{F}$ capacitor. The pressure coil of the wattmeter having a resistance 1000Ω and an inductive reactance of 15Ω is connected across a 50 Hz supply. The current coil of the wattmeter, a variable resistor R and the capacitor are connected in series across the same supply. The wattmeter deflection is made zero by adjusting the value of R to 1.65Ω . If the current coil resistance is 0.1Ω and its inductance negligible ; determine the power factor of the capacitor.

$$\text{Solution : Phase angle of pressure coil circuit } \beta = \tan^{-1} \frac{15}{1000} = 0.015 \text{ rad} = 51.6'$$

$$\text{Capacitive reactance } X_c = \frac{10^6}{2\pi \times 50 \times 20} = 159.2 \Omega.$$

Let r be the series resistance of the capacitor.

Total resistance of the load circuit including resistance of current coil.

$$= 0.1 + 1.65 + r = 1.75 + r \text{ ohm.}$$

$$\therefore \phi = \text{phase angle of load circuit} = \tan^{-1} \frac{159.2}{1.75 + r}$$

The load circuit has a leading p.f. as the reactance is capacitive.

For leading p.f.

Reading of wattmeter $\propto \cos \beta \cos (\phi + \beta)$.

For a wattmeter reading to be zero, $\cos \beta \cos (\phi + \beta) = 0$

$$\text{or} \quad \cos (\phi + \beta) = 0$$

$$\text{or} \quad \phi + \beta = 90^\circ$$

$$\text{or} \quad \phi = 90^\circ - 51.6' = 89^\circ 8.4'$$

$$\text{and} \quad \tan \phi = 66.6$$

$$\text{Hence,} \quad \frac{159.2}{1.75 + r} = 66.6 \text{ or resistance of capacitor } r = 0.64 \Omega$$

$$\text{Impedance of capacitor} = \sqrt{(159.2)^2 + (0.64)^2} = 159.2 \Omega.$$

$$\text{Power factor of capacitor} = \frac{0.64}{159.2} = 0.004.$$

Example 10.7. The current coil of a wattmeter is connected in series with an ammeter and an inductive load. A voltmeter and the voltage coil are connected across a 100 Hz supply. The ammeter reading is 4.5 A and the voltmeter and wattmeter readings, are respectively, 240 V and 23 W. The inductance of voltage circuit is 10 mH and its resistance 2000 Ω . If the voltage drops across the ammeter and the current coil are negligible, what is the percentage error in the wattmeter reading.

Solution : Inductive reactance of pressure coil $= 2\pi \times 100 \times 10 \times 10^{-3} = 6.28 \Omega$.

Resistance of pressure coil circuit $= 2000 \Omega$.

$$\text{Phase angle of pressure coil circuit } \beta = \tan^{-1} \frac{6.28}{2000} = 0.00314 \text{ rad.} = 0.18^\circ = 10.8'$$

For an inductive load : Reading of wattmeter $\propto \cos \beta \cos (\phi - \beta)$

True power $\propto \cos \phi$ where $\cos \phi = \text{load power factor}$.

$$\therefore \text{ True power} = \frac{\cos \phi}{\cos \beta \cos (\phi - \beta)} \times \text{reading of wattmeter} \quad \dots(i)$$

But true power $= I^2 R = (4.5)^2 R = (4.5)^2 Z \cos \phi$, where $R = \text{resistance of load}$.

$$\text{Impedance of load } Z = \frac{240}{4.5} = 53.3 \Omega \quad \therefore \text{ True power} = (4.5)^2 \times 53.3 \cos \phi.$$

Reading of wattmeter $= 23 \text{ W}$.

Substituting these values in (i), we have :

$$(4.5)^2 \times 53.3 \cos \phi = \frac{\cos \phi}{\cos \beta \cos (\phi - \beta)} \times 23 \text{ or } \cos \beta \cos (\phi - \beta) = \frac{23}{(4.5)^2 \times 53.3} = 0.0213$$

$$\text{or } \cos 0.18^\circ \cos (\phi - 0.18^\circ) = 0.0213$$

$$\text{or } \phi = 88.96^\circ$$

$$\text{Percentage error} = \tan \phi \tan \beta \times 100 = 55.06 \times 0.00314 \times 100 = 17.3\%$$

Example 10.8. A dynamometer type of wattmeter is rated at 10 A and 100 V with a full scale reading of 1000 W. The inductance of the voltage circuit is 5 mH and its resistance is 3000 Ω .

If the voltage drop across the current coil of the wattmeter is negligible, what is the error in the wattmeter at the rated VA rating with zero power factor. Frequency is 50 Hz.

Solution : Reactance of pressure coil $\omega L = 2\pi \times 50 \times 5 \times 10^{-3} = 1.57 \Omega$.

Pressure coil phase angle $\beta = \tan^{-1} \frac{1.57}{3000} = 0.000523 \text{ rad.}$

Power factor of load, $\cos \phi = 0$ or $\sin \phi = 1$.

From Eqn. 10.22, error with zero p.f. $= VI \sin \phi \tan \beta = 100 \times 10 \times 1 \times 0.000523 = 0.523 \text{ W.}$

Example 10.9. An electro-dynamometer wattmeter is used for measurement of power in a single phase circuit. The load voltage is 100 V and the load current is 9 A at a lagging power factors of 0.1. The wattmeter voltage circuit has a resistance of 3000 Ω and an inductance of 30 mH. Estimate the percentage error in the wattmeter reading when the pressure coil is connected

(i) on the supply side, and (ii) on the load side.

The current coil has a resistance of 0.1 Ω and negligible inductance. The frequency is 50 Hz.

Comment upon the result.

Solution : Load power $= 100 \times 9 \times 0.1 = 90 \text{ W.}$

Load power factor $\cos \phi = 0.1$, $\therefore \phi = 84.26^\circ$ and $\sin \phi = 0.995$ and $\tan \phi = 9.95$.

Resistance of pressure coil circuit $R_p = 3000 \Omega$

Reactance of pressure coil circuit $= 2\pi \times 50 \times 30 \times 10^{-3} = 9.42 \Omega$.

As the phase angle of pressure coil circuit is small, $\beta \approx \tan^{-1} \frac{9.42}{3000} = 0.00314 \text{ rad.}$

(i) When the pressure coil is connected on the load side, the wattmeter measures power loss in pressure coil circuit in addition to load power.

True power $= VI \cos \phi = 100 \times 9 \times 0.1 = 90 \text{ W.}$

Let us consider only the effect of inductance.

From Eqn. 10.19 reading of wattmeter

$$= \text{true power} (1 + \tan \phi \tan \beta) = 90 (1 + 9.95 \times 0.00314) = 92.81 \text{ W.}$$

$$\text{Power loss in pressure coil circuit} = \frac{V^2}{R_p} = \frac{(100)^2}{3000} = 3.33 \text{ W.}$$

\therefore Reading of wattmeter considering the power loss in pressure coil circuit

$$= 92.81 + 3.33 = 96.14 \text{ W.}$$

$$\text{Percentage error} = \frac{96.14 - 90}{90} \times 100 = 6.82\%$$

(ii) When the current coil is on the load side, the wattmeter measures the power in the load plus the power loss in the current coil. In fact, the current coil acts as a load.

$$\therefore \text{Total power} = \text{power consumed in load} + I^2 R_c = 90 + (9)^2 \times 0.1 = 98.1 \text{ W.}$$

$$\text{Impedance of load} = \frac{100}{9} = 11.1 \Omega.$$

$$\text{Resistance of load} = 11.1 \times 0.1 = 1.11 \Omega. \quad \text{Reactance of load} = 11.1 \times 0.995 = 11.05 \Omega.$$

$$\text{Resistance of load plus resistance of current coil} = 1.11 + 0.1 = 1.21 \Omega.$$

$$\text{Reactance} = 11.05 \Omega.$$

$$\text{Impedance of load including current coil} = \sqrt{(1.21)^2 + (11.05)^2} = 11.1 \Omega.$$

$$\text{Power factor of load including current coil} = \frac{1.21}{11.1} = 0.109$$

$$\therefore \phi = 83.74^\circ \text{ and } \tan \phi = 9.12.$$

$$\therefore \text{Reading of wattmeter} = 98.1 (1 + 9.2 \times 0.00314) = 100.9 \text{ W.}$$

$$\text{Percentage error} = \frac{100.9 - 90}{90} \times 100 = 12.1\%$$

It is clear from above that in low power factor circuits we should not use a connection where the current coil is on the load side as it results in greater errors.

Example 10.10. The current coil of a dynamometer wattmeter is connected to a 24 V d.c. source in series with a 6Ω resistor. The potential circuit is connected through an ideal rectifier in series with a 50 Hz source of 100 V. The inductance of pressure circuit and current coil resistance are negligible. Compute the reading of the wattmeter.

$$\text{Solution : Current through the current coil} = \frac{24}{6} = 4 \text{ A.}$$

The pressure coil is energised by an ideal rectifier. Therefore, the pressure coil carries current during one half cycle and in the other half cycle there is no current in it. This means that there is a deflecting torque on the meter during one half cycle.

$$\therefore \text{Reading of wattmeter} = \text{average power over a cycle}$$

$$= \frac{1}{2\pi} \left[\int_0^{2\pi} vi \, d\theta \right] = \frac{1}{2\pi} \left[\int_0^{\pi} \sqrt{2} \times 100 \sin \theta \times 4 \, d\theta \right] = 181 \text{ W.}$$

10.8. Torsion head Electro-dynamometer Wattmeters

These instruments are used for precision laboratory measurements. The moving or pressure coil is suspended from a torsion head with the help of a metallic suspension. This suspension serves as a lead to the coil. The moving coil is situated entirely, inside the fixed current coil. The system is made 'astatic' to eliminate the errors caused by stray magnetic fields.

The torsion head is provided with a scale. When the wattmeter is connected in a circuit to measure power, there is a deflection of the moving system from its zero position. The reading is taken in terms of scale divisions through which the torsion head is turned back to bring the moving system from its deflected position to zero position. The number of divisions turned through when multiplied by the constant of the instrument gives the value of power.

For these wattmeters, a deflection of a few degrees is allowed on either side of zero.

Eddy current errors are minimized by winding the fixed coil with stranded conductors and by the use, wherever possible, of non-conducting materials for frames and supports.

In the Drysdale single phase astatic wattmeter, the moving coil is stitched to a flat strip of mica. The moving coil is divided into two parts wound so that current circulates in clockwise direction in one part and anticlockwise in the other part thus providing an astatic movement. The moving system is suspended by a silk fibre together with a spiral spring which gives the required torsion. The current is led into the moving coil by two fine phosphor bronze wires. The fixed coil is also divided into two halves, which are wound so as to have opposite directions of current. The conductor used for current coil has 10 strands insulated from each other. Thus in fact there are 10 current coils which may be connected in different combinations to give different current ranges. Damping is provided by mica strip which carries the moving (pressure) coil. The error due to pressure coil inductance can be made negligible if the resistance of pressure coil circuit is at least $3000 \Omega/\text{mH}$ of inductance.

10.9. Ferrodynamic Wattmeters. The operating torque can be considerably increased by using iron cores for the coils. Ferrodynamic wattmeters employ cores of low loss iron so that there is a large increase in the flux density and consequently an increase in operating torque with little loss in accuracy.

Fig. 10.11 shows a ferrodynamic wattmeter. The fixed coil is wound on a laminated core having pole pieces designed to give a uniform radial field throughout the air gap. The moving coil is asymmetrically pivoted and is placed over a hook shaped pole piece.

This type of construction permits the use of a long scale upto about 270° and gives a deflecting torque which is almost proportional to the average power.

With this construction there is a tendency on the part of the pressure coil to creep (move further on the hook) when only the pressure coil is energised. This is due to the fact that coil tries to take up a position where it links with maximum flux. The creep causes errors and a compensating coil is put to compensate for this voltage creep.

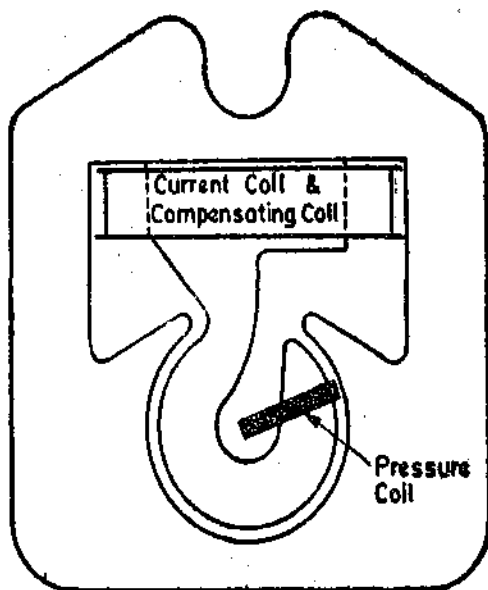

Fig. 10.11. Ferrodynamic wattmeter.

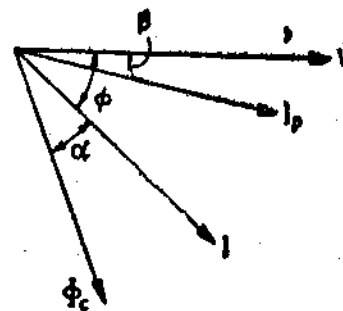

Fig. 10.12. Phasor diagram of Ferrodynamic wattmeter.

The use of ferromagnetic core makes it possible to employ a robust construction for the moving element. Also the instrument is less sensitive to external magnetic fields. On the other hand, this construction introduces complementary errors due to non-linearity of magnetization curve and introduction of large eddy current and hysteresis losses in the core.

The iron losses cause the phase angle of flux Φ_c (produced by the current coil) to lag behind current I in this coil by an angle α (See Fig. 10.12). Therefore the deflection is :

$$\theta = I_p I \frac{dM}{d\theta} \cos(\phi + \alpha - \beta) = K_1 \frac{dM}{d\theta} \cdot V I \cos(\phi + \alpha - \beta)$$

Fulfilling the condition $\alpha = \beta$, we have

$$\theta = K_1 \frac{dM}{d\theta} V I \cos \phi = K_2 P.$$

Thus the phase angle error of the wattmeter will be zero.

In order to fulfil the condition $\alpha = \beta$ at comparatively high values of α , angle β is increased. This requires the inductance of pressure coil circuit to be increased which is done by using unifilar winding for the series resistor instead of a bifilar winding. Owing to large iron losses and a large inductance the calibration is useful over a very narrow range of frequency.

A capacitance may be used to shunt the moving coil and a part of its series resistance so as to compensate for the effects of inductance of coil and the iron losses.

10'10. Cambridge Reflecting Wattmeter. It is a precision type dynamometer wattmeter which employs nickel iron cores. The moving coil assembly is entirely surrounded by the nickel-iron core (Fig. 10'13) and therefore it provides good screening. Since the reluctance of iron parts is negligible the reluctance of the magnetic circuit is entirely provided by iron and therefore hysteresis effects are

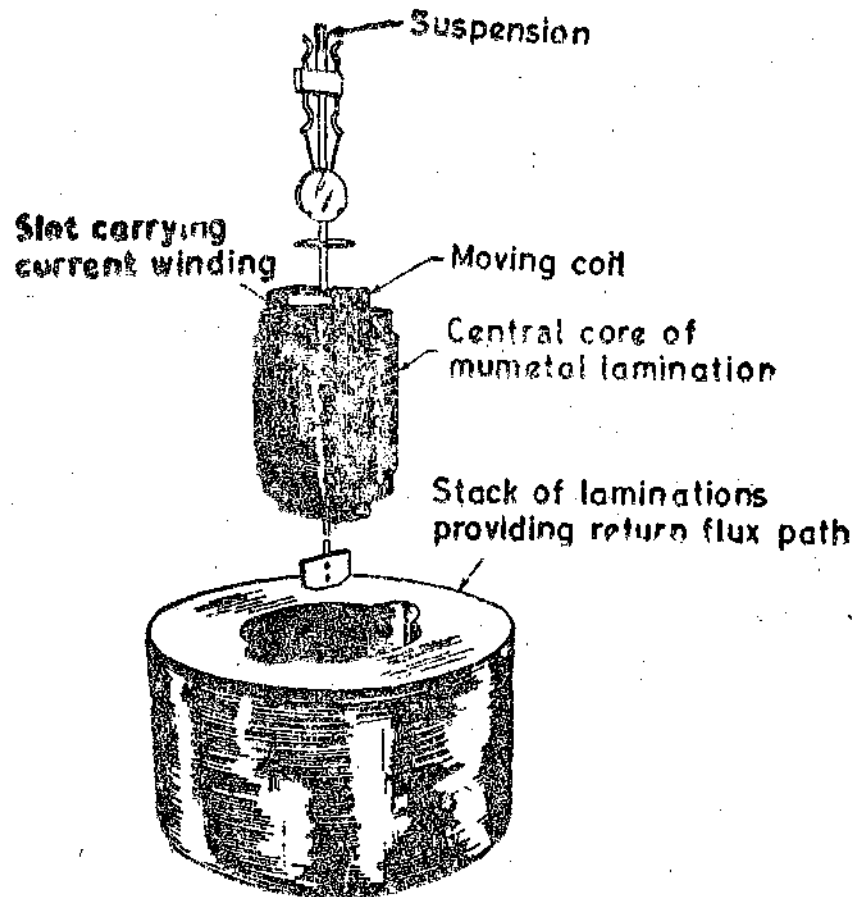

Fig. 10'13. Cambridge reflecting wattmeter.

negligible. The eddy current losses are reduced by laminating the cores. The eddy current losses can be compensated over a wide range of frequencies by connecting a capacitor across a part of pressure coil circuit resistor.

10'11. Low Power Factor Wattmeters (Electrodynamometer type)

Measurement of power in circuits having low power factor by ordinary electro-dynamometer wattmeters is difficult and inaccurate because :

(i) the deflecting torque on the moving system is small (owing to low power factor) even when the current and pressure coils are fully excited ;

(ii) errors introduced because of inductance of pressure coil tend to be large at low power factors.

Special features are incorporated in an electro-dynamometer wattmeter to make it a low power factor type of wattmeter. These features are discussed in details below :

1. Pressure Coil Current

The pressure coil circuit is designed to have a low value of resistance, so that the current, flowing through it, is increased to give an increased operating torque. The pressure coil current in a low power factor wattmeter may be as much as 10 times the value employed for high power factor wattmeters.

2. Compensation for Pressure coil Current

The power being measured in a low power factor circuit is small and current is high on account of low power factor, connection of Fig. 10.8 (a) cannot be used because owing to large load current there would be a large power loss in the current coil and, therefore, the wattmeter will give a large error.

If we use connection of Fig. 10.8 (b), the power loss in the pressure coil circuit is included in the reading given by the wattmeter. Thus with this connection also the wattmeter will give a serious error as the power loss in the pressure coil may be a large percentage of the power being measured.

Therefore, it is absolutely necessary to compensate for the pressure coil current in a low power factor wattmeter. This compensation is the same as is shown in Fig. 10.9.

3. Compensation for Inductance of Pressure coil

The error caused by pressure coil inductance is : $V I \sin \phi \tan \beta$. (Eqn. 10.22)

Now, with low power factor, the value of ϕ is large and, therefore, the error is correspondingly large. Hence in a low power factor wattmeter we must compensate for the error caused by inductance of the pressure coil. This is done by connecting a capacitor across a part of series resistance in the pressure coil circuit as shown in Fig. 10.7.

If we incorporate the features discussed above, the low factor wattmeter can be represented as shown in Fig. 10.14.

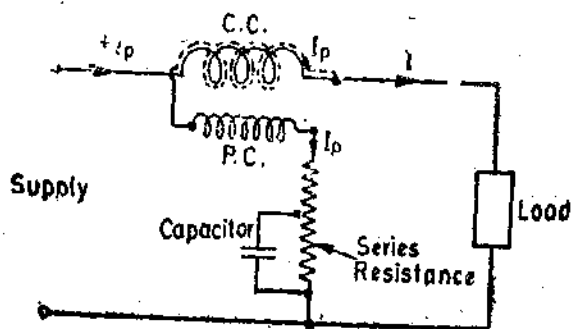

Fig. 10.14. Low power factor wattmeter.

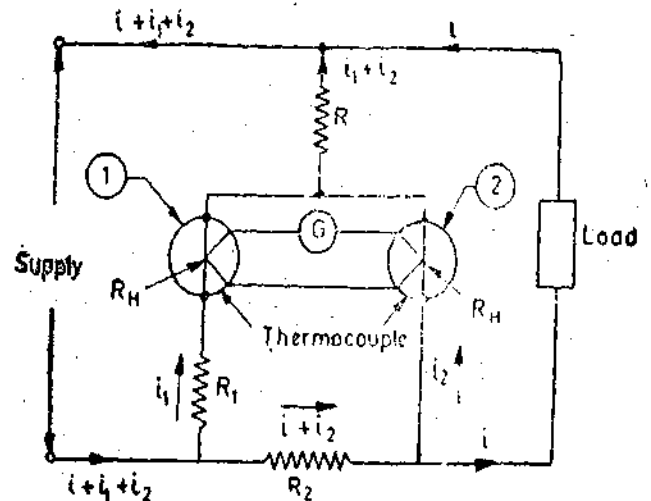

Fig. 10.15. Thermocouple wattmeter (thermal watt-converter).

4. Small Control Torque. Low power factor wattmeters are designed with to have a small control torque so that they give full scale deflection for power factors as low as 0.1.

10.12. Thermocouple Wattmeter (Thermal Watt Converter). The arrangement for measuring power with thermocouples is shown in Fig. 10.15. This method uses two similar thermocouples whose outputs are connected in opposition with a galvanometer in between.

R_H is the resistance of each thermocouple heating element

Emf of thermocouple 1

$$e_1 \propto \text{heat produced by heating element} \propto i_1^2 R_H$$

Emf of thermocouple 2 $e_2 \propto i_2^2 R_H$

$$\text{Emf across the galvanometer} = e_1 - e_2$$

$$\therefore \text{Instantaneous deflecting torque of galvanometer } T_i = K_1(e_1 - e_2) = K_2(i_1^2 - i_2^2)$$

where K_1 and K_2 are constants.

Let v be the instantaneous voltage at the load, and i the instantaneous load current.

$$\text{Therefore, we can write } i_1(R_H + R_1) = (i_1 + i_2)R_2 + i_2 R_H \quad \text{and} \quad i_2 R_H + (i_1 + i_2)R = v.$$

From these two equations we get :

$$i_1 = \frac{v(R_H + R_2) + iR_2(R_H + R)}{(R_H + R)(R_H + R_1) + R(R_H + R_2)}; \quad i_2 = \frac{v(R_H + R_1) - iR_2R}{(R_H + R)(R_H + R_1) + R(R_H + R_2)}$$

Instantaneous deflecting torque of galvanometer $T_i = K_2 (i_1^2 - i_2^2)$

Substituting the values of i_1 and i_2 in the above expression and assuming $R_1 = R_2$ for simplicity, we have :

$$T_i \propto \left\{ \frac{2viR_1(R_H + 2R)}{(R_H + R_1)[(R_H + R_1)^2 + R^2]} + \frac{i^2R_1^2[(R_H + R)^2 - R^2]}{(R_H + R_1)^2[(R_H + R_1)^2 + R^2]} \right\} = K(Avi + Bi^2) \quad \dots(10.23)$$

where A and B are constants involving the resistances. If $R_H + R$ is not very different from R , then B is almost equal to zero and Bi^2 may be neglected as compared to Avi

$$\therefore \text{Instantaneous torque } T_i = K'vi = \text{instantaneous power}, \quad \dots(10.24)$$

where K' is a constant.

Thus the galvanometer may be calibrated to read the power.

The above analysis assumes that the two thermocouples are identical and also that they have a square law response.

The commercial thermo-couple wattmeters use a number of thermocouples connected in the form of a chain so as to increase the output. They also use current and potential transformers.

A thermal watt converter used for a.c. circuits is described below.

The power in an a.c. circuit is given by $P = VI \cos \phi$. Fig. 10.16 shows a phasor diagram where current I lags behind voltage V by an angle ϕ .

The sum S of the two phasors can be found by relationship

$$S^2 = V^2 + I^2 + 2VI \cos \phi \quad \dots(i)$$

where S represents the sum of phasors V and I .

Similarly the difference D , between the two phasors is found from

$$D^2 = V^2 + I^2 - 2VI \cos \phi \quad \dots(ii)$$

Subtracting (ii) from (i) we obtain

$$S^2 - D^2 = 4VI \cos \phi \quad \text{or} \quad \text{Power } P = VI \cos \phi = \frac{1}{4}(S^2 - D^2) \quad \dots(10.25)$$

Thus a circuit arrangement capable of measuring quantity $S^2 - D^2$ can measure a quantity proportional to $VI \cos \phi$ representing power. A thermal watt converter using instrument transformers can be used for the purpose.

Fig. 10.17 shows the schematic diagram of the elementary circuit of the thermal watt-converter. The plain arrows show the direction of the current from the current transformer, and flagged arrows show the direction of the current in potential circuit at a given instant of time.

The heating element of thermocouple A receives the sum of the currents produced by the current transformer and the potential circuit. The heating element of thermocouple B , however, receives the difference of these currents. Through proper design, the heat generated in the thermocouples and hence the developed emf, is proportional to the square of the current in the heater. Therefore, thermocouple A develops an emf proportional to S^2 and thermocouple B develops an emf proportional to D^2 . The outputs of these thermocouples are so connected that the two emfs oppose each other. Then the emf measured by the millivoltmeter is :

$$E = K(S^2 - D^2) = K_1P \quad \dots(10.26)$$

where K and K_1 are constants.

Therefore, the deflection of the millivoltmeter is proportional to power.

In practice, chains of thermocouples are used instead of single thermocouples in order to obtain greater emf and hence greater sensitivity. The thermocouples are self heating and are similar

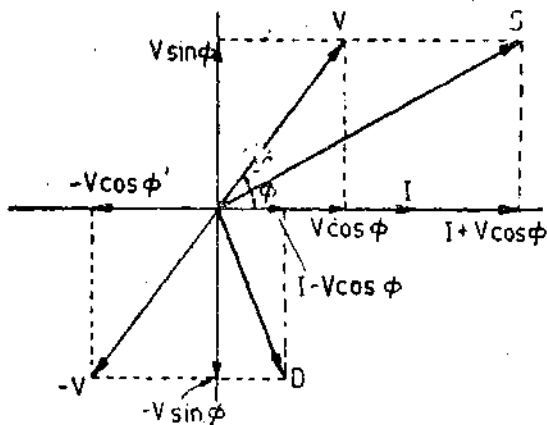

Fig. 1.016.

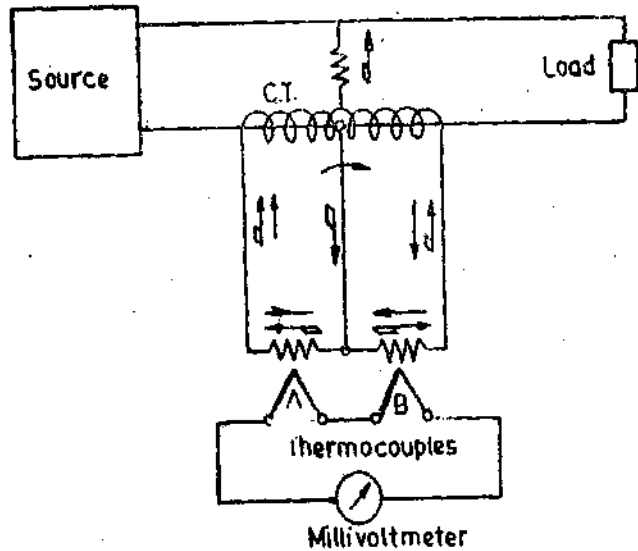
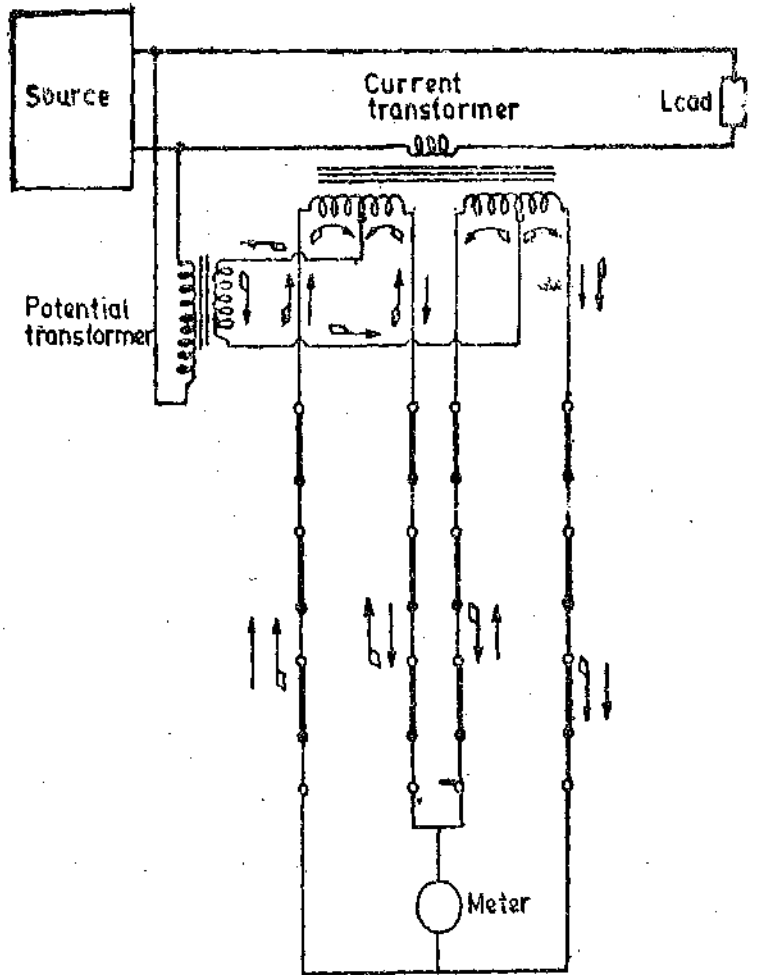

Fig. 10'17. Elementary circuit of a thermal watt converter.

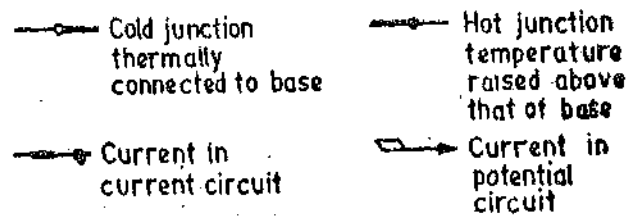

Fig. 10'18. Circuit diagram of thermal watt converter.

to those of the bridge type element discussed on page 252. . The practical circuit is shown in Fig. 10'18.

Thermal wattconverters are widely used for measurement of power in different circuits, and the sum of their outputs can be applied to a recording potentiometer for graphic record of total power consumed. They are also used for calibration of both d.c. as well as a.c. instruments and for instrumentation process monitoring.

Thermocouple wattmeters can be used for measurements of power in several circuits and the sum of their outputs can be applied to a recording potentiometer which records the total power.

10'13. Electrostatic Wattmeters. The electrostatic wattmeter is a precision or laboratory type instrument and has no commercial applications. It finds its greatest sphere of application in the measurement of power of small magnitude and low power factor and also when the voltage of the system is high as for example, in cable dielectric loss measurements.

Although for dielectric loss measurements, it has been superseded by more sophisticated bridge methods, but it requires less expensive apparatus, is easy to handle and is capable of very

accurate results. A conventional type of quadrant electrometer may be used to measure power when connected as shown in Fig. 10'19.

Let e = instantaneous value of voltage across load,
 i = instantaneous value of load current,
 v, v_1 and v_2 = instantaneous values of potential of needle and two pairs of quadrants respectively.

The instantaneous torque $T: \alpha(v-v_1)^2 - (v-v_2)^2$... (i)

Now $v-v_2$ = voltage across load = e and $v-v_1 = (v-v_2) + (v_2-v_1) = e + iR$.

Substituting these values in (i)

$$T: \alpha(e+iR)^2 - (e)^2 \quad \alpha 2eiR + i^2R^2 \quad \alpha 2R \left[ei + \frac{i^2R}{2} \right]$$

α instantaneous power in load plus half the power loss in the non-inductive resistance.

The simple connections given in Fig. 10'19 have the disadvantage that the power measured is different from the actual (true) power by an amount equal to half the power loss in the resistance R .

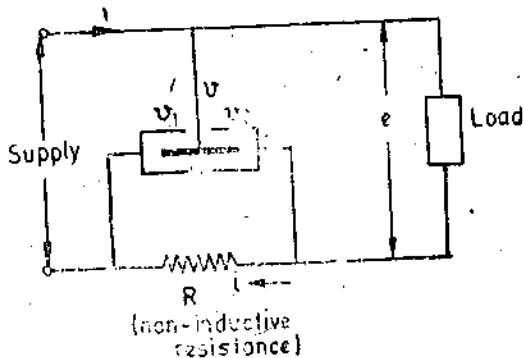

Fig. 10'19. Electrostatic wattmeter.

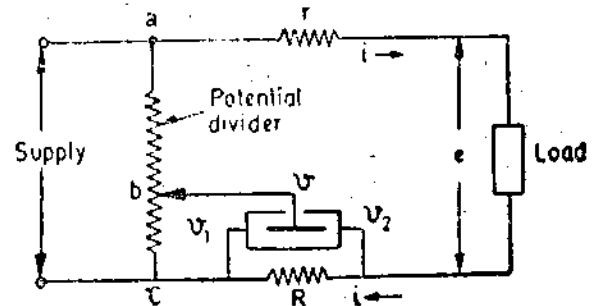

Fig. 10'20. Electrostatic wattmeter (Due to Prof. Miles Walker).

This disadvantage may be overcome by many methods. One of the methods is given below. The connections of this method which is due to Prof. Miles Walker, are shown in Fig. 10'20.

There is a non-inductive resistor r connected in series with the load, and the needle of the electrometer is connected to a suitable point on the potential divider. This potential divider may be the high voltage winding of the supply transformer from which tapings are brought out.

Let $\frac{\text{voltage between } a \text{ and } c}{\text{voltage between } b \text{ and } c} = n$.

Voltage between a and $c = ir + e + iR = e + ir + iR$

Voltage between b and $c = v - v_1 \quad \therefore v - v_1 = \frac{e + ir + iR}{n}$

and $v - v_2 = (v - v_1) - (v_2 - v_1) = (v - v_1) - iR = \frac{e + ir + iR}{n} - iR$

The instantaneous torque is $T: \alpha(v-v_1)^2 - (v-v_2)^2, \alpha \left(\frac{e + ir + iR}{n} \right)^2 - \left(\frac{e + ir + iR}{n} - iR \right)^2$

$$\alpha 2iR \left(\frac{e + ir + iR}{n} \right) - i^2R^2, \alpha \frac{2iRe}{n} + \frac{2i^2rR}{n} + \frac{2i^2R^2 - ni^2R^2}{n}$$

Now if we make $r = \frac{R}{2} (n-2)$,

the instantaneous torque is thus $T_i \propto \frac{2iRe}{n} + 2i^2 \frac{R^2}{2n} (n-2) + \frac{2i^2 R^2 - ni^2 R^2}{n}$, $\propto \frac{2iRe}{n}$,

$\propto ei$

\propto true instantaneous power in load.

Therefore, the instrument can be calibrated to read the true power directly.

Electrostatic wattmeters do not suffer from the errors at low power factor which are inherent in the electro-dynamometer type. They are free from waveform, frequency and eddy current errors. However, they have the disadvantage of having a very small deflecting torque.

10.14. Induction Type Wattmeters The induction type wattmeters work on the same principle as that of induction ammeters and voltmeters (see page 270). These wattmeters can only be used for a.c. power measurements.

Construction The instrument consists of two laminated electromagnets. One is called a "shunt" magnet and its coil is excited by voltage of the circuit and hence this coil carries a current proportional to the voltage. The second magnet is called a "series" magnet and its coil is excited by the load current (or a definite fraction of it). The coil which carries a current proportional to the voltage is known as "pressure coil" while the coil carrying the load current is known as "current coil".

A thin aluminium disc mounted on a spindle is so placed that it cuts the flux of both the magnets (Fig. 10.21).

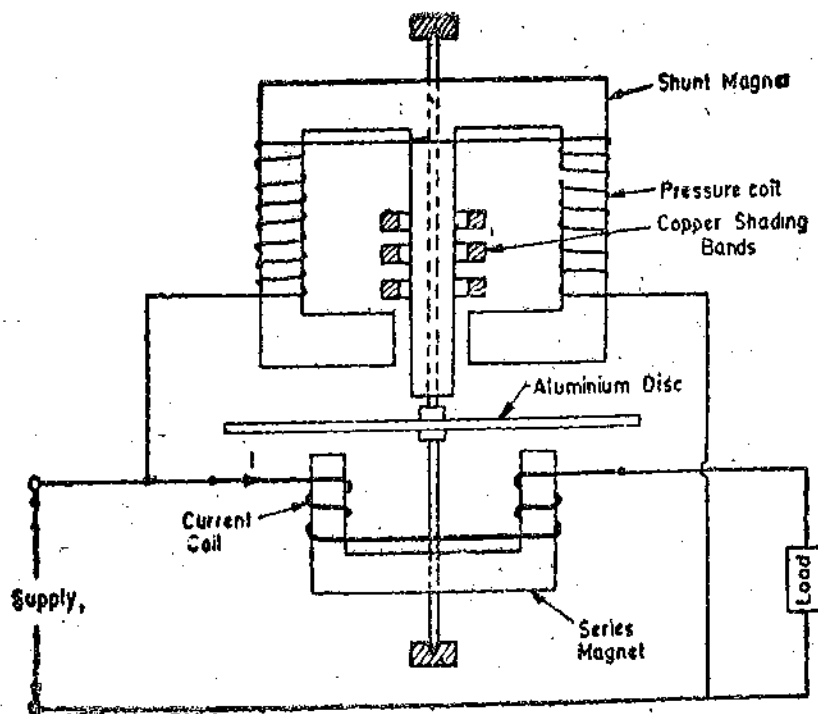

Fig. 10.21. Induction type wattmeter.

For the arrangement shown in Fig. 10.21, the pressure coils are so connected that they force the flux through the central limb. The series magnet carries two current coils in series. These coils are so wound that they magnetize the core in the same direction.

The central limb is provided with copper shading bands. The position of these shading bands is adjustable in order to make the shunt magnet flux lag exactly 90° behind the applied voltage.

The instrument is provided with springs for exerting the controlling torque.

Unlike the dynamometer type of instrument, the pressure coil of an induction wattmeter is made as inductive as possible in order that the shunt magnet flux lags the applied voltage by nearly 90° .

Eddy current damping is used for the instrument.

Principle of Operation. The shunt and series magnets produce alternating fluxes. These fluxes produce eddy emfs in the disc and in turn cause eddy currents to flow. These eddy currents interact with the fluxes to produce a deflecting torque.

Theory. The theory and operation of induction type wattmeter is similar to that of an induction type watthour meter. The only difference is that in an induction wattmeter, a control spring restricts the motion of the disc by exerting a controlling torque while in an induction watthour energy meter, the disc is allowed to rotate continuously. Therefore, for theory of this instrument, refer to Chapter 11 on induction type watthour meters.

$$\text{Deflecting torque } T_d = K_1 VI \cos \phi = K_1 P$$

where $P = VI \cos \phi = \text{power in the circuit,}$

$$\text{Controlling torque } T_c = K\theta$$

$$\therefore \text{ Deflection } \theta = \frac{K_1}{K} P = K' VI \cos \phi.$$

where K_1 and K' are constants.

Shape of Scale. The deflection is directly proportional to the power being measured and therefore, the instrument has a uniform scale.

Errors (i) Temperature changes cause variation in the resistance of the moving element, and, therefore, the magnitude of eddy currents changes. This causes changes in the deflecting torque. The error on this account is partly neutralized by a balancing effect due to change in temperature of the windings.

(ii) Variation of frequency effect the reactances of windings and, therefore, cause errors. But these instruments are very useful as panel instruments where the variation in frequency are not much.

Advantages and Disadvantages

Advantages. (i) These instruments have a large deflecting torque and, therefore, are unaffected by stray magnetic fields.

(ii) They are robust in construction and have a very long scale extending upto 300° .

Disadvantages. (i) They have a heavy moving system and are less accurate.

(ii) Their power consumption is high.

(iii) They can be used only on a.c.

10.15. Lipman Type Induction Wattmeter. A Lipman type induction wattmeter is shown in Fig. 10.22. The wattmeter consists of two parts—a fixed and a moving system. The fixed system consists of a U shaped electromagnet energized by the potential coil. Another coil is also wound around the core of this electromagnet. This coil is used for power factor compensation through an adjustable resistance.

The magnetic circuit is completed through an internal fixed cruciform core. The current coil is wound around one of the limbs of the cruciform core. The moving system consists of a thin aluminium cylinder which is free to rotate in the air gap between the poles of the external and the internal electromagnets. The spindle to which the moving cylinder is attached revolves between two

jewelled bearings. The pointer is attached to this spindle. The damping is due to eddy currents produced by a permanent magnet. Controlling torque is produced by springs.

The flux Φ_p is produced by the potential coil while flux Φ_c is produced by the current coil. It is clear that flux Φ_p (due to potential coil) passes horizontally through the rotor (aluminium cylinder) while flux Φ_c (due to current coil) passes horizontally through the rotor.

The two fluxes are 90° apart in space and are alternating in nature with a phase displacement in time and, therefore, they produce a torque (as is produced in a Ferraris type of instrument). The two fluxes Φ_p and Φ_c are brought in quadrature with each other in time with the help of the adjustable resistance R . The advantage of this instrument is that its power consumption is small.

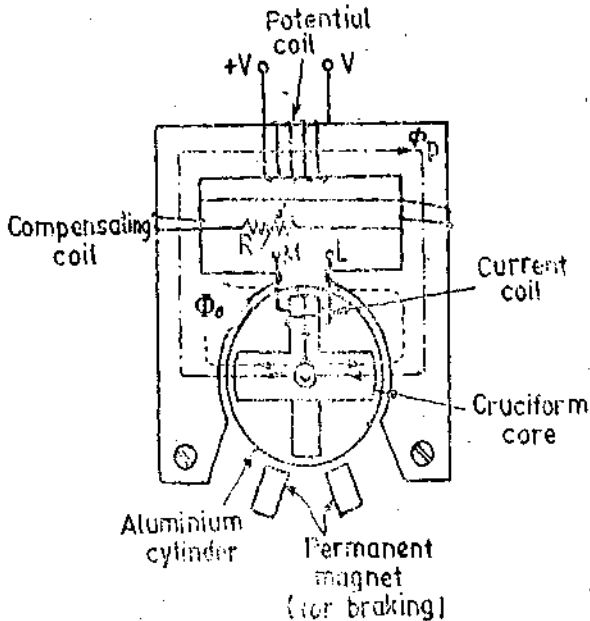

Fig. 10'22. Lipman type induction wattmeter.

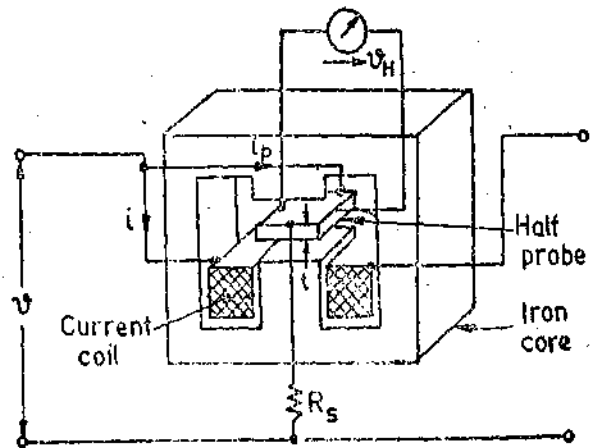

Fig. 10'23. Hall effect multiplier.

10'16. Hall Effect Multiplier. In applications where the power is to be controlled or processed further, Hall Effect Multipliers are used. A Hall effect multiplier is shown in Fig. 10'23. The Hall effect multiplier uses a Hall effect element as explained in Art 6'3 page 125.

The current is passed through the current coil which produces a magnetic field proportional to the current i . This field is perpendicular to the Hall effect element. A current i_p , proportional to the voltage is passed through the Hall element in a direction perpendicular to field as shown. The current is limited by the multiplier resistance R_s . The output voltage of the Hall effect multiplier is :

$$v_H = R_H \frac{i_p B}{t} \quad \dots(10'27)$$

where R_H = Hall co-efficient ; V-m/A-Wb m^{-2} ,
 B = flux density ; Wb/ m^2 ,

t = thickness of Hall element ; m.

Now $B \propto i$ and $i_p = \frac{v}{R_s} \propto v$.

Hence $v_H \propto vi$

\therefore The output voltage of the Hall effect multiplier is proportional to instantaneous power.

Hence the voltmeter connected at the output terminals can be calibrated in terms of power. The Hall effect voltage which is representative of the power, can be processed further for control and other purposes. This is the major advantage of Hall effect multiplier over electrodynamicometer wattmeters the output of the later being the deflection of a pointer which cannot be processed further.

10.17. Measurement of Power using Instrument Transformers. Power measurements are made

in high voltage circuits connecting the wattmeter to the circuit through current and potential transformers as shown in Fig. 10.24.

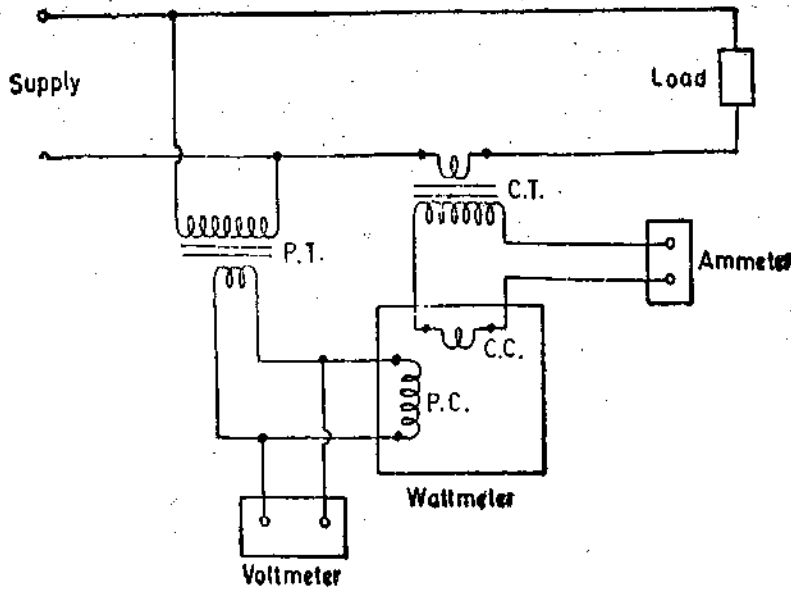

The primary winding of the C.T. is connected in series with the load and the secondary winding is connected in series with an ammeter and the current coil of a wattmeter.

The primary winding of the potential transformer is connected across the supply lines and a voltmeter and the potential coil circuit of the wattmeter are connected in parallel to the secondary winding of the transformer. One secondary terminal of each transformer and the casings are earthed.

Fig. 10.24. Power measurement using instrument transformers.

are subject to ratio and phase angle errors. The errors in good modern instrument transformers are small and may be ignored for many purposes. However, they must be considered in precision work. Also in some power measurements these errors, if not taken into account, may lead to very inaccurate results.

Voltmeters and ammeters are effected by only ratio errors while wattmeters are influenced in addition by phase angle errors. Corrections can be made for these errors if test information is available about the instrument transformers and their burdens.

Fig. 10.25 gives the phasor diagrams for the current and voltages of load, and in the wattmeter coils. Fig. 10.25 (a) refers to a load having lagging power factor while Fig. 10.25 (b) to a load with leading power factor.

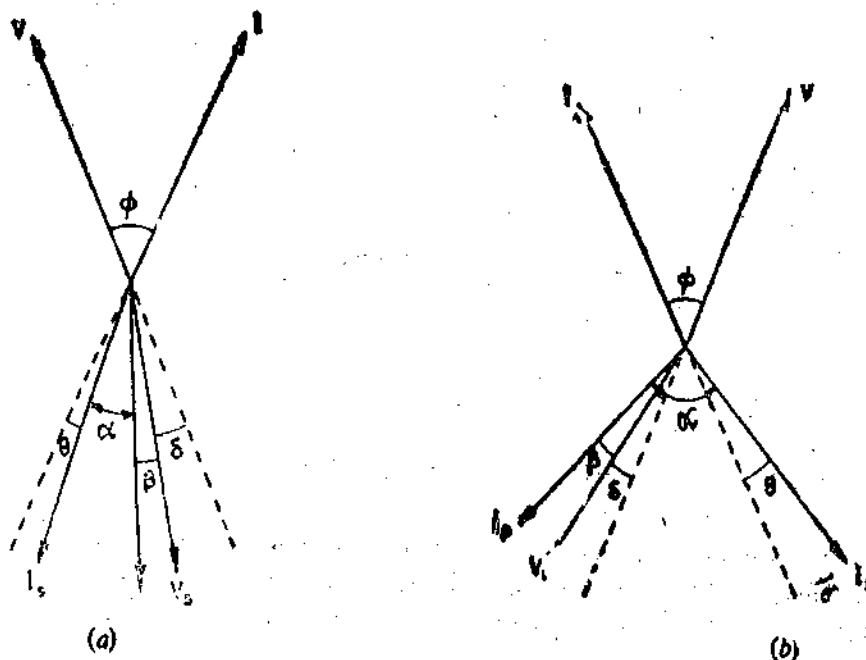

Fig. 10.25. Phasor diagrams for arrangement for power measurement with instrument transformers.

Let V = voltage across the load,

I = load current,

ϕ = phase angle between current and voltage,

α = phase angle between currents in the current and pressure coils of wattmeter,

V_s = voltage across secondary of the potential transformer,

= voltage across the pressure coil circuit of wattmeter,

I_s = secondary current of current transformer = current in wattmeter current coil,

I_p = current in the wattmeter pressure coil,

β = angle by which I_s lags V_s on account of inductance of pressure coil,

δ = phase angle of potential transformer,

and θ = phase angle of current transformer.

The phasors shown dotted are V and I reversed.

For lagging power factor. Consider Fig. 10'24 (a). The phase angle of C.T. is +ve (I_s reversed leads I) and the phase of P.T. is -ve (V_s reversed lags V). For such a case, phase angle of load is :

$$\phi = \alpha + \theta + \delta + \beta \quad \dots(10'28)$$

In general the phase angle of P.T. may be negative or positive.

For positive phase angle of P.T., phase angle of load $\phi = \alpha + \theta - \delta + \beta \quad \dots(10'29)$

Leading power factor. Fig. 10'24 (b) shows the case when the phase angle of P.T. is negative. For such a case,

Phase angle of load $\phi = \alpha - \theta - \delta - \beta \quad \dots(10'30)$

If the phase angle of P.T. is +ve, $\phi = \alpha - \theta + \delta - \beta \quad \dots(10'31)$

Correction factors. The correction factors—neglecting for the present, the ratio of transformer is:

$$K = \frac{\cos \phi}{\cos \beta \cos \alpha} \quad \dots(10'32)$$

where α can be calculated from Eqns. 10'27 to 10'31 depending upon the conditions of the circuit.

\therefore Power = $K \times$ actual ratio of P.T. \times actual ratio of C.T. \times wattmeter reading, $\dots(10'33)$

= $K \times RCF$ of P.T. $\times RCF$ of C.T. \times nominal ratio of P.T. \times nominal ratio of C.T. \times wattmeter reading. $\dots(10'34)$

Example 10'11. The indication on a 110 V, 5 A wattmeter used in conjunction with potential and current transformers of nominal ratios of 100/1 and 20/1, is 350 W. If the resistance and inductance of the wattmeter pressure coil circuit are 362 Ω and 100 mH respectively and the ratio errors and phase angles of potential and current transformers at particular working conditions are +0.8%, -45' and -0.2%, +90', what is the true value of the power being measured? The load phase angle is 50° lagging. Frequency is 50 Hz.

Solution. Reactance of pressure coil circuit = $2\pi \times 50 \times 10 \times 10^{-3} = 3.14 \Omega$.

Resistance of pressure coil circuit = 362 Ω .

Phase angle of pressure coil circuit $\beta = \tan^{-1} \frac{3.14}{362} = 30'$

Phase angle of current transformer $\theta = +90'$.

Phase angle of potential transformer $\delta = -45'$, Phase angle of load = 50°.

Phase angle between pressure coil current I_p and current I_s of wattmeter current coil (See Fig. 10'26).

$$\alpha = \phi - \theta - \beta - \delta = 50^\circ - 90' - 30' - 45' = 47^\circ 15'$$

$$\text{Correction factor } K = \frac{\cos \phi}{\cos \beta \cos \alpha}$$

$$= \frac{\cos 50^\circ}{\cos 30' \times \cos 47^\circ 15'} = 0.947.$$

$$\text{Percentage ratio error} = \frac{K_n - R}{R} \times 100$$

$$\therefore \text{Actual ratio } R = \frac{K_n \times 100}{100 + \text{percentage ratio error}}$$

$$\text{Actual ratio of C.T.} = \frac{20 \times 100}{100 - 0.2} = 20.04.$$

$$\text{Actual ratio of P.T.} = \frac{100 \times 100}{100 + 0.8} = 99.2.$$

From Eqn. 10'32.

$$\text{Power of load} = 0.947 \times 20.04 \times 99.2 \times 350 \times 10^{-3} \text{ kW.}$$

$$= 658.9 \text{ kW.}$$

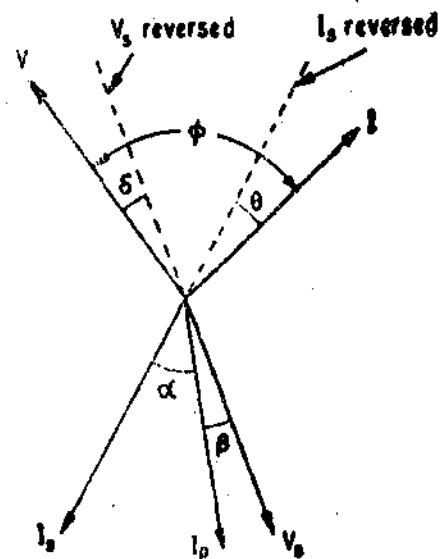

Fig. 10'26

Example 10'12. The power in a single phase high voltage circuit is measured by using instrument transformers with voltmeter, ammeter and wattmeter. Observed readings of the instruments (assuming no errors) are 115 V, 4.5 A and 200 watt. Characteristics of the transformers are

P.T. : nominal ratio : 11500/115 V ; ratio correction factor 0.995 ; phase angle, $-25'$.

C.T. : nominal ratio. 25/5 A ; ratio correction factor 0.997, phase angle ; $+15'$.

Neglecting the voltage phase angle in the voltmeter calculate the true power.

Solution. The phasor diagram is drawn in Fig. 10'27.

Phase angle between secondary current and voltage = α

$$\cos \alpha = \frac{\text{wattmeter reading}}{V.P.T.} = \frac{200}{115 \times 4.5} = 0.3865.$$

$$\therefore \alpha = 67^\circ 16'$$

From the phasor diagram 10'27, phase angle of load

$$\phi = \alpha + \theta + \delta = 67^\circ 16' + 15' + 25' = 67^\circ 56'.$$

$$\therefore \cos \phi = 0.3757.$$

$$\text{Correction factor } K = \frac{\cos \phi}{\cos \beta \cos \alpha}$$

$\beta = 0$ as inductance of pressure coil circuit is negligible.

$$\therefore K = \frac{0.3757}{1 \times 0.3865} = 0.972$$

From Eqn. 10'33, actual power

$$= 0.972 \times 0.995 \times 0.997 \times \frac{11500}{115} \times \frac{25}{5} \times 200 = 96430 \text{ W,}$$

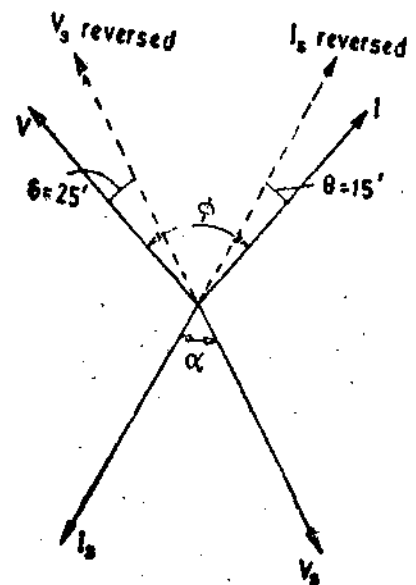

Fig. 10'27

10.18. Power in Poly-Phase Systems

Blondel's Theorem. If a network is supplied through n conductors, the total power is measured by summing the readings of n wattmeters so arranged that a current element of a wattmeter is in each line and the corresponding voltage element is connected between that line and a common point. If the common point is located on one of the lines, then the power may be measured by $n-1$ wattmeters.

Consider the simple case of a 3 phase, 3 wire system and load as shown in Fig. 10.28.

The potential coils of the wattmeters are connected to a common point C . The potential of point C is different from that of the neutral point O of the load. Let this difference be v .

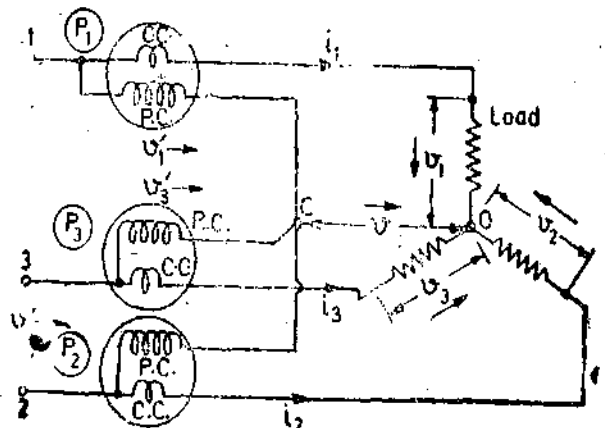

Fig. 10.28. Power measurement

The instantaneous power in the load

$$p = v_1 i_1 + v_2 i_2 + v_3 i_3$$

Reading of wattmeter P_1 , $p_1 = v_1' i_1$

Reading of wattmeter P_3 , $p_3 = v_3' i_3$

Reading of wattmeter P_2 , $p_2 = v_2' i_2$

Now

$$v_1 = v + v_1', v_2 = v + v_2', \text{ and } v_3 = v + v_3'$$

$$\therefore p_1 = (v_1 - v) i_1, p_2 = (v_2 - v) i_2 \text{ and } p_3 = (v_3 - v) i_3.$$

Sum of the wattmeter readings = $p_1 + p_2 + p_3$

$$= (v_1 - v) i_1 + (v_2 - v) i_2 + (v_3 - v) i_3 = v_1 i_1 + v_2 i_2 + v_3 i_3 - v (i_1 + i_2 + i_3)$$

Applying Kirchhoff's current law $i_1 + i_2 + i_3 = 0$

$$\therefore \text{Sum of the wattmeter readings} = v_1 i_1 + v_2 i_2 + v_3 i_3 = p. \tag{10.35}$$

Eqn. 10.35 represents the total instantaneous power measured by the three wattmeters. Hence the sum of the readings is equal to the total power in the load.

10.19. Measurement of Power in Three Phase Circuits

1. **Three Wattmeter Method.** The connections as employed for a 3 phase 4 wire system are shown in Fig. 10.29.

In this case, the common point C of pressure coils and the neutral O of the load coincide and therefore,

$$v = 0$$

and $v_1 = v_1', v_2 = v_2', v_3 = v_3'$.

Sum of the instantaneous readings of the wattmeters $p = p_1 + p_2 + p_3 = v_1 i_1 + v_2 i_2 + v_3 i_3$

Instantaneous power of load

$$= v_1 i_1 + v_2 i_2 + v_3 i_3$$

Hence these three wattmeters measure the power of the load.

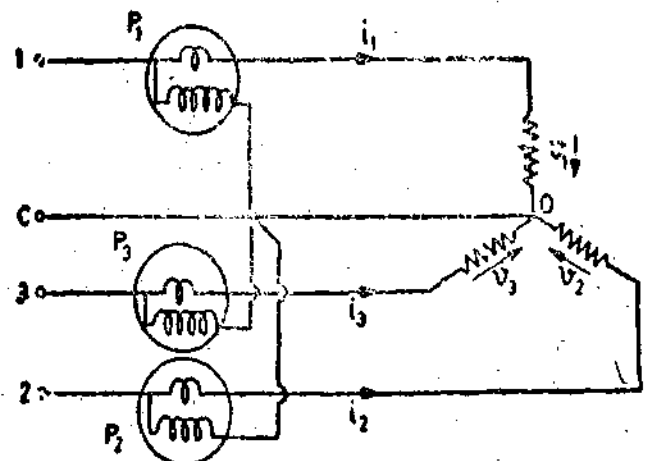

Fig. 10.29. Three wattmeter method.

2. **Two Wattmeter Method.** In a three phase three wire system we require 3 elements. But if we make the common points of the pressure coils coincide with one of the lines, then we will require only $n-1=2$ elements.

$$\text{Instantaneous power consumed by load} = v_1 i_1 + v_2 i_2 + v_3 i_3$$

Let us consider two wattmeters connected to measure power in three phase circuits as shown in Fig. 10.30 (Star connection) and Fig. 10.31 (Delta connection).

Star (Wye) connection. Instantaneous reading of P_1 wattmeter $p_1 = i_1(v_1 - v_3)$.
 Instantaneous reading of P_2 wattmeter $p_2 = i_2(v_2 - v_3)$
 Sum of instantaneous readings of two wattmeters $= p_1 + p_2$
 $= i_1(v_1 - v_3) + i_2(v_2 - v_3) = v_1 i_1 + v_2 i_2 - v_3(i_1 + i_2)$

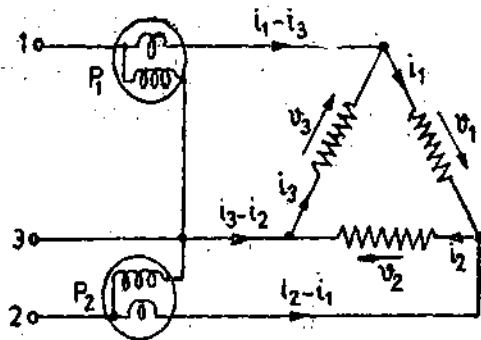
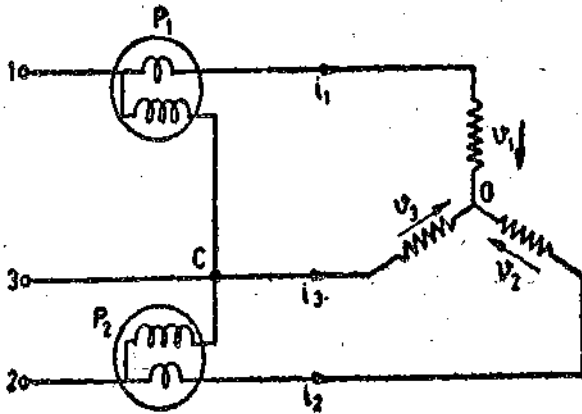

Fig. 10'30. Two wattmeter method (Star connection).
 From Kirchhoff's law (Fig. 10'29)

Fig. 10'31. Two wattmeter method (Delta connection).

$$i_1 + i_2 + i_3 = 0 \quad \text{or} \quad i_3 = -(i_1 + i_2)$$

\therefore Sum of instantaneous readings of two wattmeters $= v_1 i_1 + v_2 i_2 + v_3 i_3$

Therefore, the sum of the two wattmeter reading is equal to the power consumed by the load. This is irrespective of whether the load is balanced or unbalanced.

Delta Connection

Instantaneous reading of P_1 wattmeter $p_1 = -v_3(i_1 - i_3)$

Instantaneous reading of P_2 wattmeter $p_2 = v_2(i_2 + i_1)$

\therefore Sum of instantaneous readings of wattmeters P_1 and P_2

$$p_1 + p_2 = -v_3(i_1 - i_3) + v_2(i_2 + i_1) = v_2 i_2 + v_3 i_3 - i_1(v_2 + v_3)$$

From Kirchhoff's voltage law, $v_1 + v_2 + v_3 = 0 \quad \therefore v_1 = -(v_2 + v_3)$

Hence sum of instantaneous readings of wattmeter

$$= v_2 i_2 + v_3 i_3 - i_1(-v_1) = v_1 i_1 + v_2 i_2 + v_3 i_3$$

Therefore, the sum of the two wattmeter readings is equal to the power consumed by the load. This is irrespective of whether the load is balanced or unbalanced.

Fig. 10'32 shows the phasor diagram for a balanced star connected load of Fig. 10'30.

Let V_1, V_2, V_3 be the rms values of phase voltage and I_1, I_2, I_3 be the rms values of phase currents.

The load is balanced, therefore

Phase voltages $V_1 = V_2 = V_3 = V$ (say)

Line voltages $V_{12} = V_{23} = V_{13} = \sqrt{3}V$

Phase currents $I_1 = I_2 = I_3 = I$ (say)

Line currents $I_1 = I_2 = I_3 = I$

Power factor $= \cos \phi$.

The phase currents lag the corresponding phasor voltages by an angle ϕ .

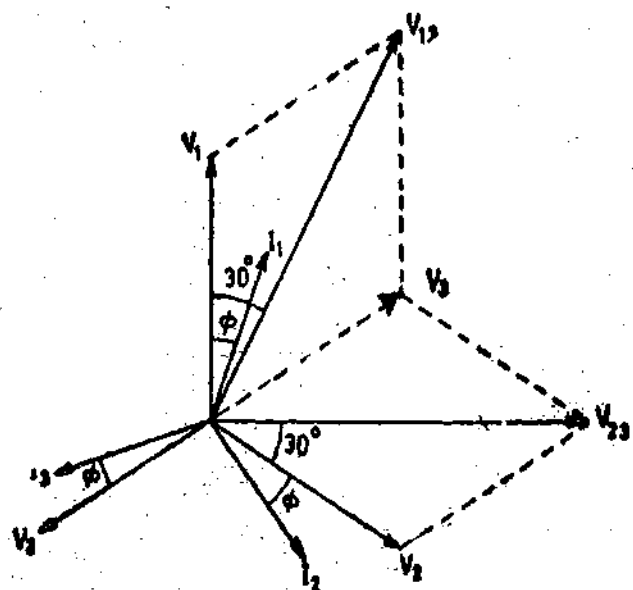

Fig. 10'32. Phasor diagram for balanced star connected load.

The current through wattmeter P_1 is I_1 and voltage across its pressure coil is V_{13} . I_1 leads V_{13} by an angle $(30^\circ - \phi)$.

$$\therefore \text{Reading of } P_1 \text{ wattmeter, } P_1 = V_{13} I_1 \cos(30^\circ - \phi) = \sqrt{3} VI \cos(30^\circ - \phi) \quad \dots(10.36)$$

The current through wattmeter P_2 is I_2 and voltage across its pressure coil is V_{23} . I_2 lags V_{23} by an angle $(30^\circ + \phi)$

$$\therefore \text{Reading of } P_2 \text{ wattmeter, } P_2 = V_{23} I_2 \cos(30^\circ + \phi) = \sqrt{3} VI \cos(30^\circ + \phi) \quad \dots(10.37)$$

Sum of reading of two wattmeters

$$P_1 + P_2 = \sqrt{3} VI [\cos(30^\circ - \phi) + \cos(30^\circ + \phi)] = 3 VI \cos \phi. \quad \dots(10.38)$$

This is the total power consumed by load.

$$\therefore \text{Total power consumed by load } P = P_1 + P_2 \quad \dots(10.39)$$

Difference of readings of two wattmeters

$$P_1 - P_2 = \sqrt{3} VI [\cos(30^\circ - \phi) - \cos(30^\circ + \phi)] = \sqrt{3} VI \sin \phi \quad \dots(10.40)$$

$$\frac{P_1 - P_2}{P_1 + P_2} = \frac{\sqrt{3} VI \sin \phi}{3 VI \cos \phi} = \frac{\tan \phi}{\sqrt{3}} \quad \text{or} \quad \phi = \tan^{-1} \sqrt{3} \frac{P_1 - P_2}{P_1 + P_2} \quad \dots(10.41)$$

$$\text{Power factor } \cos \phi = \cos \left(\tan^{-1} \sqrt{3} \frac{P_1 - P_2}{P_1 + P_2} \right)$$

Effect of power factor on the readings of wattmeters :

(1) With unity p.f. $\cos \phi = 1$ and $\phi = 0$

The readings of the two wattmeters are :

$$P_1 = \sqrt{3} VI \cos(30^\circ - \phi) = \sqrt{3} VI \cos 30^\circ = \frac{3}{2} VI$$

$$\text{and} \quad P_2 = \sqrt{3} VI \cos(30^\circ + \phi) = \sqrt{3} VI \cos 30^\circ = \frac{3}{2} VI$$

$$\text{Total power } P = 3 VI \cos \phi = 3 VI.$$

Thus at unity power factor, the readings of the two wattmeters are equal, each wattmeter reads half of total power.

(2) When p.f. = 0.5, we have $\phi = 60^\circ$.

$$\text{Therefore, } P_1 = \sqrt{3} VI \cos(30^\circ - \phi) = \sqrt{3} VI \cos(30^\circ - 60^\circ) = \frac{3}{2} VI$$

$$\text{and} \quad P_2 = \sqrt{3} VI \cos(30^\circ + \phi) = \sqrt{3} VI \cos(30^\circ + 60^\circ) = 0$$

$$\text{Total power } P = 3 VI \cos \phi = \frac{3}{2} VI.$$

Therefore, when the power factor is 0.5, one of the wattmeters reads zero and the other reads total power.

(3) When p.f. = 0, we have $\phi = 90^\circ$

$$\text{Therefore, } P_1 = \sqrt{3} VI \cos(30^\circ - \phi) = \sqrt{3} VI \cos(30^\circ - 90^\circ) = -\frac{\sqrt{3}}{2} VI$$

$$\text{and} \quad P_2 = \sqrt{3} VI \cos(30^\circ + \phi) = \sqrt{3} VI \cos(30^\circ + 90^\circ) = -\frac{\sqrt{3}}{2} VI$$

$$\text{Total power } P = 3 VI \cos \phi = 0$$

Therefore, with zero power factor, the readings of the two wattmeters are equal but of opposite sign.

It should be noted that when the power factor is below 0.5, one of the wattmeters will give negative indication. Under these conditions in order to read the wattmeter, we must either reverse the current coil or the pressure coil connections. The wattmeter will then give a positive reading but this must be taken as negative for calculating the total power.

3. **One Wattmeter Method.** The method can be used only when the load is balanced. The connections are shown in Fig. 10.33. The current coil is connected in one of the lines and one end

of the pressure coil to the same line, other end being connected alternately to the other two lines. The phasor diagram is shown in Fig. 10'33.

We have, $V_1 = V_2 = V_3 = V$, $I_1 = I_2 = I_3 = I$ and $V_{13} = V_{12} = \sqrt{3}V$.

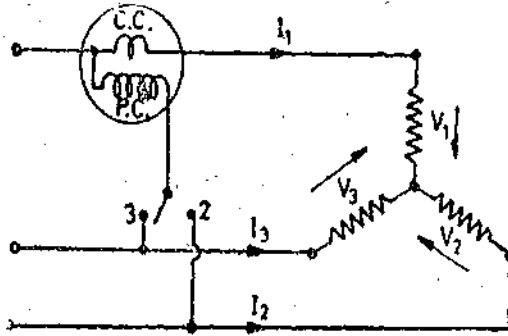

Fig. 10'33. One wattmeter method.

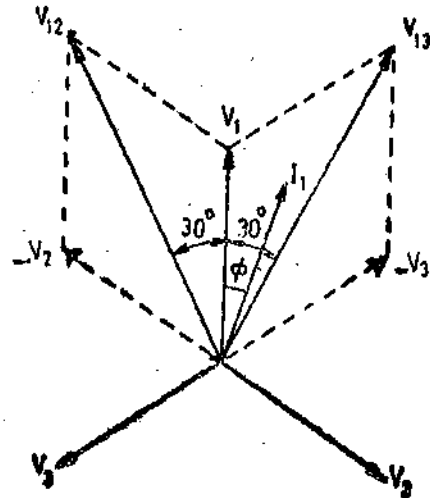

Fig. 10'34. Phasor diagram of one wattmeter method.

Reading of wattmeter when the switch is at 3

$$P_1 = V_{13} I_1 \cos (30^\circ - \phi) = \sqrt{3} VI \cos (30^\circ - \phi)$$

Reading of wattmeter when the switch is at 2

$$P_2 = V_{12} I_1 \cos (30^\circ + \phi) = \sqrt{3} VI \cos (30^\circ + \phi)$$

Sum of the two wattmeter readings

$$P_1 + P_2 = \sqrt{3} VI [\cos (30^\circ - \phi) + \cos (30^\circ + \phi)] = 3 VI \cos \phi.$$

Thus the sum of the two readings is the power consumed by the load, or $P = P_1 + P_2$.

Proceeding as in the two wattmeter method, $\tan \phi = \sqrt{3} \frac{P_1 - P_2}{P_1 + P_2}$... (10'41)

and power factor $\cos \phi = \cos \left[\tan^{-1} \sqrt{3} \frac{P_1 - P_2}{P_1 + P_2} \right]$

10'20. Three Phase Wattmeters. A dynamometer type three phase wattmeter consists of two separate wattmeter movements mounted together in one case with the two moving coils mounted on the same spindle. The arrangement is shown in Fig. 10'35.

There are two current coils and two pressure coils.

A current coil together with its pressure coil is known as an element. Therefore, a three-phase wattmeter has 2 elements.

The connections of 2 elements of a 3 phase wattmeter are the same as that for two wattmeter method using two single phase wattmeters.

The torque on each element is proportional to the power being measured by it. The total torque deflecting the moving system is the sum of the deflecting torque of the two elements.

Deflecting torque of element 1 $\propto P_1$ Deflecting torque of element 2 $\propto P_2$

\therefore Total deflecting torque $\propto (P_1 + P_2) \propto P$

Hence the total deflecting torque on the moving system is proportional to the total power.

In order that a 3 phase wattmeter read correctly, there should not be any mutual interference between the two elements. A laminated iron shield may be placed between the two elements to eliminate the mutual effects.

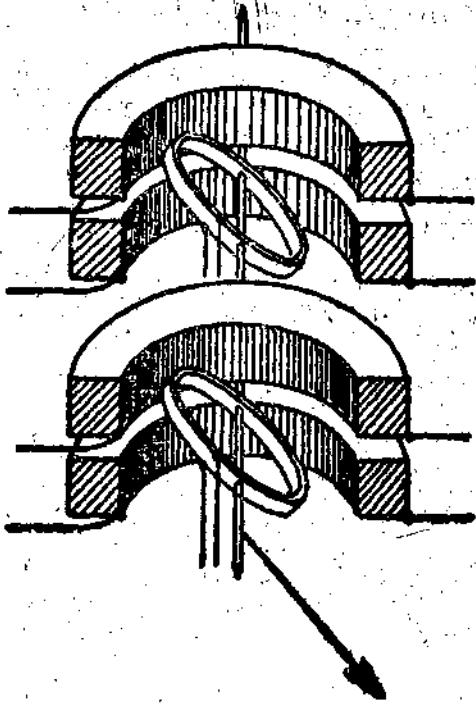

Fig. 10'35. Three phase two element wattmeter.

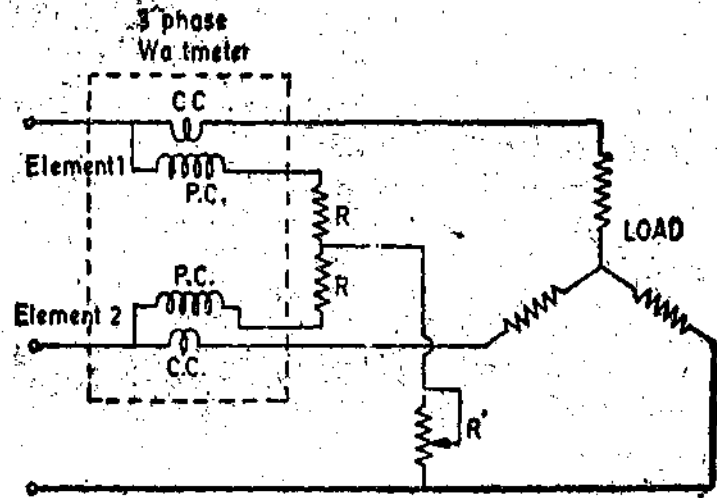

Fig. 10'36. Compensation for mutual effects between two elements of a 3 phase wattmeter.

Compensation for mutual effects can be done by using Weston's method. The arrangement is shown in Fig. 10'36. Resistance R' may be adjusted to compensate for errors caused by mutual interference.

10'21. Measurement of Reactive Power. The reactive power in a circuit is $Q = VI \sin \phi$.

It is often convenient and even essential that the reactive power be measured. For example, in load monitoring, such a measurement gives the operator or load despatcher information concerning the nature of the load. Also the reactive power serves as a check on power factor measurements, since ratio of reactive and active power is $\tan \phi = Q/P$.

Also the apparent power VI , which determines the line and generator capacity, may be determined from measurements of active and reactive power.

$$VI = \sqrt{P^2 + Q^2}$$



(a)

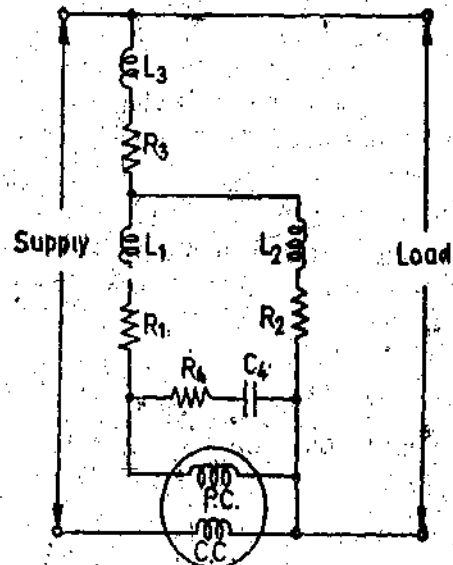

(b)

Fig. 10'37. Single phase varmeter.

1. **Single Phase Varmeters.** In a single phase circuit reactive power can be measured by a varmeter (volt-ampere reactive meter). This is an electrodynamic wattmeter in whose pressure coil circuit a large inductive reactance is substituted for the series resistance so that the pressure coil current is in quadrature with the voltage. Under these conditions the wattmeter reads :

$$VI \cos (90^\circ - \phi) = VI \sin \phi = \text{reactive power.}$$

The circuit of a varmeter is shown in Fig. 10'37 (b).

It should be noted that varmeters do not read correctly if harmonics are present or if the frequency is different from that used when calibrating the instrument.

2. **Polyphase Varmeters.** In three phase circuits phase shifting necessary for the measurement of reactive power is usually obtained from phase shifting transformers. This phase shifting may be done with two auto-transformers connected in an "Open Delta" configuration as shown in Fig. 10'38. The current coils of the wattmeters are connected in series with the lines as usual. The potential coils are connected as shown. Phase-line 2 is connected to the common terminals of the two auto-transformers, and phase 1 and 3 lines are connected to 100% taps on the

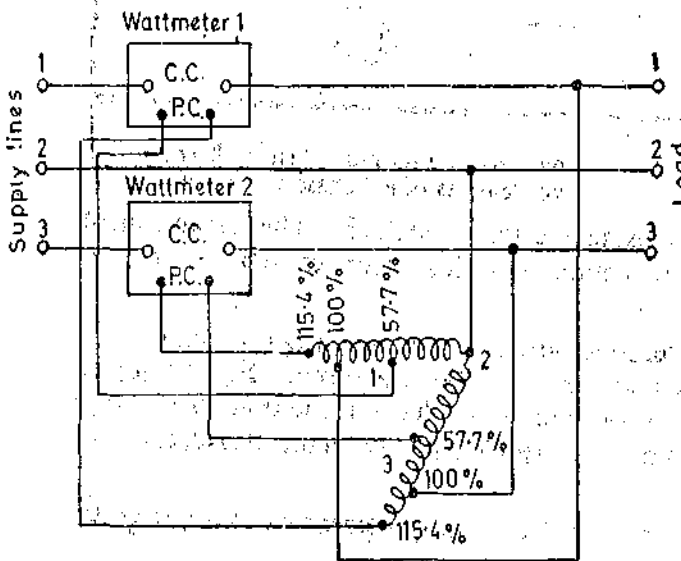

Fig. 10'38. Reactive power measurement with two auto-transformers.

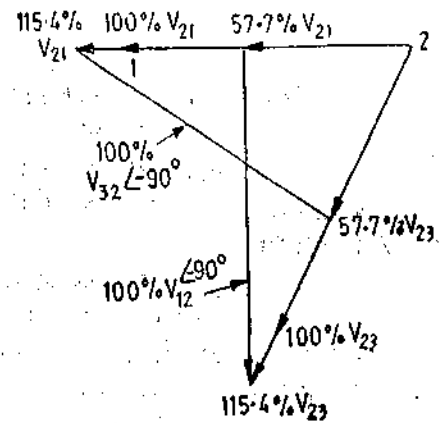

Fig. 10'39. Phasor diagram for connection of Fig. 10'38.

transformers. Both transformers will produce 115.4 percent of line voltage across the total winding. The pressure coil of wattmeter 1 is connected from 57.7 percent tap on transformer 1 to the 115.4 percent tap on transformer 2, which produces a voltage equal to line voltage but shifted by 90°. This is shown in phasor diagram of Fig. 10'39. The pressure coil of wattmeter 2 is connected in a similar way. Since both the coils receive a voltage equal to the line voltage but displaced by 90°, the wattmeters read the reactive power consumed by the load. The arithmetic sum of the two wattmeters gives the total reactive power supplied to the load.

3. **Reactive power measurement in three phase circuits.** In the case of balanced three phase circuits, it is simple to use a single wattmeter to read the reactive power. The current coil of the wattmeter is connected in one line and the pressure coil is connected across the other two lines as shown in Fig. 10'40 (a).

Referring to Fig. 10'40 (b).

Current through the current coil = I_2 .

Voltage across the pressure coil = V_{13} .

∴ Reading of wattmeter = $V_{13} I_2 \cos (90 + \phi) = \sqrt{3} VI \cos (90 + \phi) = -\sqrt{3} VI \sin \phi$

Total reactive volt amperes of the circuit $Q = 3 VI \sin \phi = (-\sqrt{3}) \times \text{reading of wattmeter}$

Phase angle $\phi = \tan^{-1} \frac{Q}{P}$

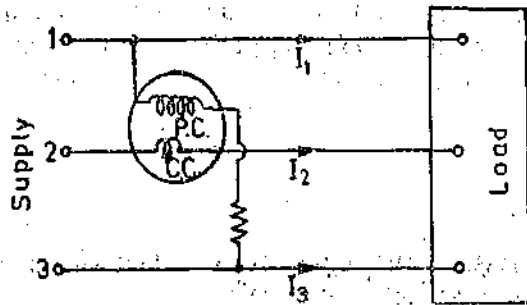

Fig. 10.40. (a) Reactive power measurement with one wattmeter.

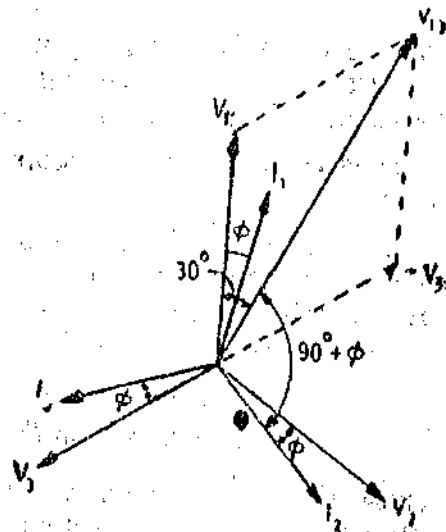

Fig. 10.40 (b) Phasor diagram for connections of Fig. 10.40 (a).

10.22. Summation Metering. It is sometimes necessary and convenient to measure the total power in a number of three phase branch circuits and to indicate the summation on a single instrument. This summation is done with a polyphase wattmeter together with current transformers. The function of current transformers is to add the currents from various branches as shown in Fig. 10.41. This diagram shows two circuits whose power is to be summed up.

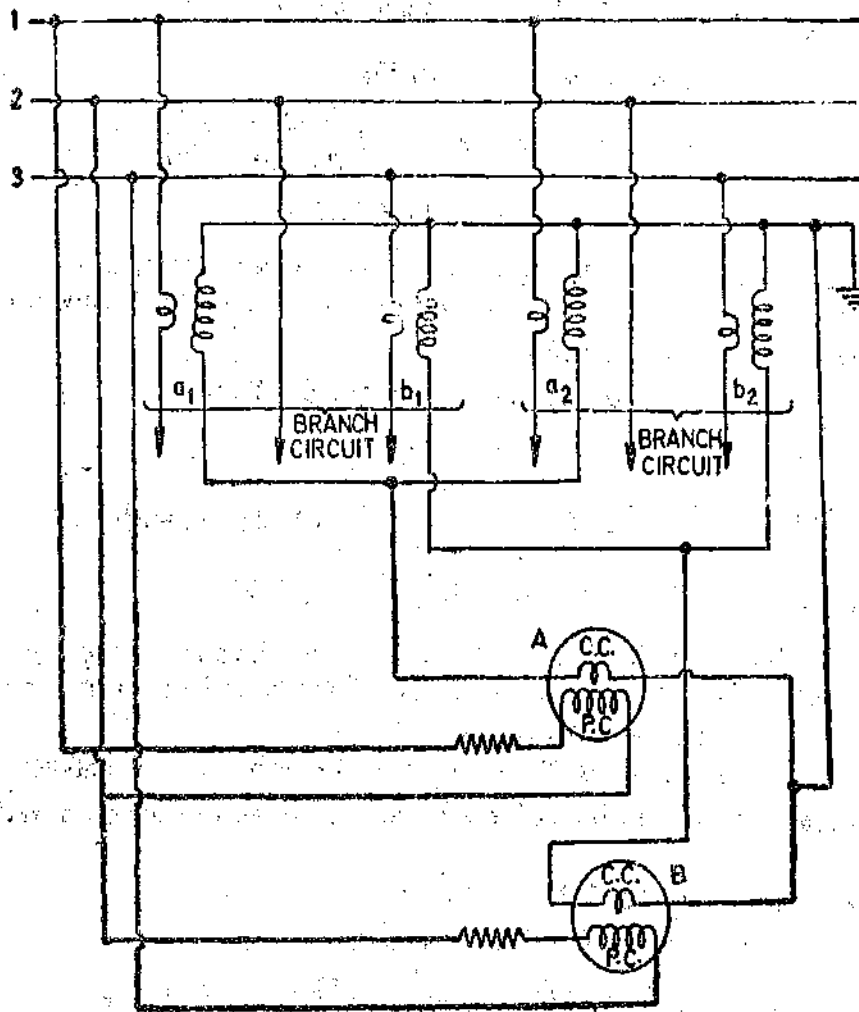

Fig. 10.41. Summation metering.

4. If the reactance of the pressure coil circuit of a wattmeter is 1 per cent of its resistance, calculate the percentage error due to this cause at power-factors of 0.8, 0.5 and 0.1 respectively. [Ans. 0.75%, 1.7%, 9.95%]
5. If the current in the pressure coil of a wattmeter lags 2° behind the voltage, and the instrument is accurate when $\cos \phi = 1$, find the percentage error when $\cos \phi = 0.8, 0.6$ and 0.4 respectively. [Ans. 2.56%, 4.59%, 7.94%]
6. The voltage circuit of an electrodynamic wattmeter has an inductance of 8 mH and a resistance of 2000 Ω . What is the percentage error of the instrument when measuring an inductive load having a phase angle of 89° at 50 Hz. Neglect the impedance of the current coil and assume the potential circuit current is negligible as compared with the load current. [Ans. 7.2%]
7. A certain circuit takes 10 A at 200 V and the power absorbed is 1000 W. If the wattmeter's current coil has a resistance of 0.15 Ω and its pressure coil a resistance of 5000 Ω and an inductance of 0.3 H, find: (a) the error due to resistance for each of the two possible methods of connection; (b) the error due to inductance if the frequency is 50 Hz; (c) the total error in each case. [Ans. (a) 15 W, 8 W (b) 33 W (c) 48 W, 41 W]
8. A dynamometer wattmeter measures power in a 50 Hz, single phase circuit without error, at all power factors. The resistance of the voltage coil and its series resistance are 400 Ω and 10,000 Ω respectively. The series resistance has a distributed self-capacitance equivalent to a shunt capacity of 20 pF. What is the self-capacitance of the pressure coil? [Ans. 2mH]
9. A voltage: $100 \sin \omega t + 40 \cos (3 \omega t - 30^\circ) + 50 \sin (5 \omega t + 45^\circ)$ V is applied to the pressure circuit of a wattmeter and through the current coil is passed a current of $8 \sin \omega t + 6 \cos (5 \omega t - 120^\circ)$ A. What will be the reading on the wattmeter? What percentage of this power is due to fundamental? [Ans. 439 W; 91.2%]
10. The inductive reactance of the pressure coil circuit of a dynamometer wattmeter is 0.4 per cent of its resistance at normal frequency and the capacitance is negligible. Calculate the percentage error and correction in or due to reactance for loads at (i) 0.707 p.f. lagging (ii) 0.5 p.f. lagging. [Ans. (a) 0.996, 0.4%; (b) 0.993, 0.7%]
11. The total resistance of the pressure circuit of a wattmeter is 4000 Ω and the inductance of the pressure coil circuit is 6.5 mH. Give the theory of the shunted capacitor method of compensating the inductance error and determine across what portion of the series resistance a 0.1 μ F capacitor should be shunted to effect compensation. [Ans. 255 Ω]
12. The resistance of the pressure circuit of a wattmeter is 200 times its reactance, the phase error of the potential transformer is 0.25° and the phase error of the current transformer 0.3° at full load, double this at 1/5 th load non-inductive, and 50 per cent more on loads of power-factor 0.5. Find the percentage errors of the wattmeter at full and at 1/5th load of power-factor 0.5 inductive. [Ans. 1.69%, 2.44%]
13. A 100 V, 5 A range wattmeter is used in conjunction with instrument transformers to measure power consumed by a load at 6 kV taking 100 A at 0.5 lagging power factor. The instrument transformers have the following data:
- P.T. nominal ratio = 60 : 1; ratio error = +1%; phase angle = -1° .
- C.T. nominal ratio = 20 : 1; ratio error = -0.5% ; phase angle = $+2^\circ$.
- Assuming the wattmeter reads correctly, find the error in the indicated power due to transformer errors. [Ans; 9.5% high]
14. In a particular measurement, the wattmeter readings were 5000 and 1000 W. Calculate the power and power factor if (a) both meters read direct and (b) one of the meters has to be reversed. [Ans. (a) 6000 W, 0.656 (b) 4000 W : 0.359]
15. Two wattmeters connected to measure the power in a 440 V, 3 phase balanced system gave readings of 5000 W and 1000 W, the latter reading being obtained after reversing the current coil connection of wattmeter. Determine what value of capacitance will cause the whole power to be read by the first wattmeter. Assume delta connection. The frequency is 50 Hz. [Ans. 497 μ F]

Measurement of Energy and Industrial Metering

11.1. General. Energy is the total power delivered or consumed over a time interval, that is
 $\text{energy} = \text{power} \times \text{time}.$

Electrical energy developed as work or dissipated as heat may be expressed as:

$$W = \int_0^t vi \, dt \quad \dots(11.1)$$

If v is expressed in V, i in A and t in s, the unit of energy is joule or watt second which is 1 watt over an interval of one second. If the unit of time is taken as hour, energy is then expressed in watt hours. In many instances, this unit, is of inconvenient size and a larger unit is used—the kilowatt hour, *i.e.*, energy consumed when power is delivered at an average rate of 1000 watt for one hour.

11.2. Motor Meters. Motor meters are used for measurement of energy on both d.c. and a.c. circuits. For d.c. circuits, the meter may be an ampere hour meter or a watt hour meter.

In motor meters the moving system revolves continuously unlike in the indicating instruments where it deflects through a fraction of a revolution. The speed of rotation is proportional to power in the case of watt hour meters and ampere hours in the case of ampere hour meters. Thus the total number of revolutions made by a watt hour meter in a given interval of time is proportional to the energy supplied (and in the case of ampere-hour meters, to the total quantity of electricity supplied). In this connection a term called meter constant is used. **Meter Constant** is defined as the number of revolutions made per kilowatt-hour (kWh). The value of meter constant is usually marked on the meter.

11.3. Braking. In a motor meter the speed of the moving system is controlled by a braking system. The braking system consists of a permanent magnet (braking magnet) so placed that it induces eddy currents in some part of the moving system. These eddy currents produce a braking (retarding) torque which is proportional to the speed of the moving system. The part in which eddy currents are produced is usually an aluminium disc. The disc is mounted on the moving system and, therefore, when the moving system revolves this disc cuts through the field of the permanent magnet.

Emf generated in the disc $e = K_1 \Phi n$

where Φ = flux of the permanent magnet, n = speed of rotation, and K_1 = a constant.

Let r be the resistance of the eddy current paths. Therefore, eddy current produced is:

$$i = \frac{e}{r} = K_1 \frac{\Phi n}{r}$$

The braking torque is produced by the interaction of the eddy current and the field of the permanent magnet. This torque is directly proportional to the product of flux of the magnet, magnitude of eddy current and the effective radius R from the axis of the disc.

$$\therefore \text{Braking torque } T_B = K_2 \Phi i R = K_1 K_2 \frac{\Phi^2 n R}{r} = K_3 \frac{\Phi^2 n R}{r} \quad \dots(11.2)$$

where K_2 and K_3 are constants.

If the radius R of the disc is constant $T_B = K_4 \frac{\Phi^2 n}{r}$... (11'3)

The moving system attains a steady speed when the driving torque is equal to the deflecting torque.

Braking torque at steady speed N is : $T_B = K_3 \frac{\Phi^2 NR}{r} = K_5 N$... (11'4)

Let T_d be the driving torque at the steady speed N .

At steady speed, $T_B = T_d$ $\therefore K_3 \frac{\Phi^2 NR}{r} = T_d$

or steady speed $N = \frac{r}{K_3 \Phi^2 R} \cdot T_d$... (11'5)

$= K' T_d$... (11'6)

Hence the steady speed attained by a meter for a constant value of driving torque T_d is directly proportional to the resistance, r , of the eddy current paths, inversely proportional to square of flux Φ of permanent magnet and inversely proportional to radius R . In order that the calibration of the meter remain the same, it is essential that the value of Φ and r should remain constant. Thus it is very important that the strength of braking magnet shall remain constant throughout the life of the meter. This constancy is assured by careful design and proper treatment of the magnet during manufacture. Temperature changes affect the value of resistance r and thus cause errors. An increase in temperature increases the resistance r and thus the braking torque is reduced.

It is necessary that the steady speed of the meter should be low and in order to achieve this the disc resistance be low and that flux of the magnet and the effective radius of the disc be large. An aluminium disc is generally preferred to a copper disc since the resistance per unit weight of aluminium is smaller. Frictional forces are limiting factor on the weight and the size of the disc and thus the radius of the disc cannot be increased unduly. Therefore in order to obtain low steady speeds, strong magnets, having large pole areas are used. The air gap is kept as small as mechanical considerations permit.

The braking torque can be adjusted by using a magnetic shunt whose distance from the magnet can be changed. If the magnetic shunt is brought near the poles, it will bypass a larger amount of flux and so the disc will cut through a smaller flux resulting in reduced braking torque. On the other hand if it is moved away from the magnet, it will bypass lesser flux giving a larger braking torque. The braking torque can also be varied by varying the radius R (See page 136). If the magnet is placed at a larger radius, the braking torque would also be larger.

11'4. Friction. Errors caused by friction are considerably more important in motor meters than the corresponding errors in the indicating instruments. This is because the friction forces are always present in a motor meter and therefore affect the speed of the rotor for any value of current or power.

Static Friction. Friction forces which exist when the rotor is just about to start revolving may prevent it from starting at all if the load is small. This friction force will also cause serious errors at low loads as the friction force is comparable to load at low loads. This will make the meter registration lower than the actual consumption. Static friction may be taken as constant when the meter is running, and may be compensated for by providing a small constant driving torque. This constant torque is applied to the rotor independent of the load.

Running Friction. When the meter is running normally, a friction torque is applied to the rotor and the magnitude of this torque is proportional to the speed of the rotor. This friction torque is of no importance as it merely adds to the braking action.

However, in some meters, such as mercury motor type, a frictional torque is produced which

is proportional to the square of the speed. This running friction causes serious errors and has to be compensated for.

The friction forces in a meter, are unavoidable. However, they must be reduced to a minimum and must remain practically constant over long periods of time. Therefore the moving parts should be made light. The jewels and pivots should be kept in good order. Spring loaded bearings should be used as their use results in lower static friction and higher life for the jewel.

The counting mechanism should have the minimum possible friction, and the worm and worm wheel connection to the spindle should be properly adjusted. The driving torque of the meter should be high so that the irregularities in friction may not cause errors.

11.5. Energy Meters for A.C. Circuits

Induction type of energy meters are universally used for measurement of energy in domestic and industrial a.c. circuits. Induction type of meters possess lower friction and higher torque/weight ratio. Also induction type meters are inexpensive and accurate and retain their accuracy over a wide range of loads and temperature conditions.

11.6. Single Phase Induction Type Watt-hour Meters

11.7. Construction. The construction varies in details from one manufacturer's product to the next. However, the differences are very minor in nature.

There are four main parts of the operating mechanism :

- (i) driving system,
- (ii) moving system,
- (iii) braking system,
- and (iv) registering system.

Fig. 11.1 shows the construction of a single phase induction type energy meter.

Driving System. The driving system of the meter consists of two electro-magnets. The core of these electromagnets is made up of silicon steel laminations. The coil of one of the electromagnets is excited by the load current. This coil is called the current coil. The coil of second electromagnet is connected across the supply and, therefore, carries a current proportional to the supply voltage. This coil is called the pressure coil. Consequently the two electromagnets are known as series and shunt magnets respectively.

Copper shading bands are provided on the central limb. The position of these bands is adjustable. The function of these bands is to bring the flux produced by the shunt magnet exactly in quadrature with the applied voltage.

Moving System. This consists of an aluminium disc mounted on a light alloy shaft. This disc is positioned in the air gap between series and shunt magnets. The upper bearing of the rotor (moving system) is a steel pin located in a hole in the bearing cap fixed to the top of the shaft. The rotor runs on a hardened steel pivot, screwed to the foot of the shaft. The pivot is supported by a jewel bearing. A pinion engages the shaft with the counting or registering mechanism.

A unique design for the suspension of the disc is used in the floating-shaft energy meter. Here the rotating shaft has a small magnet at each end, where the upper magnet of the shaft is attracted

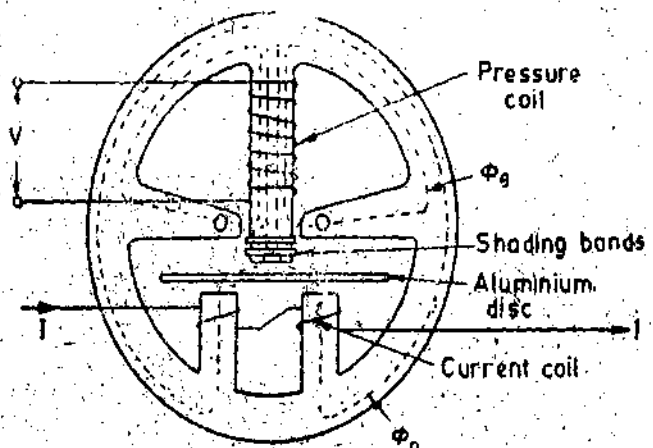

Fig. 11.1. Single phase energy meter.

to a magnet in the upper bearing and the lower magnet of the shaft is attracted to a magnet in the lower bearing. The moving system thus floats without touching either bearing surface, and the only contact with the movement is that of the gear connecting the shaft with the gear of the train, thus the friction is drastically reduces.

Braking System. A permanent magnet positioned near the edge of the aluminium disc forms the braking system. The aluminium disc moves in the field of this magnet and thus provides a braking torque. The position of the permanent magnet is adjustable, and therefore, braking torque can be adjusted by shifting the permanent magnet to different radial positions as explained earlier.

Registering (counting) Mechanism. The function of a registering or counting mechanism is to record continuously a number which is proportional to the revolutions made by the moving system.

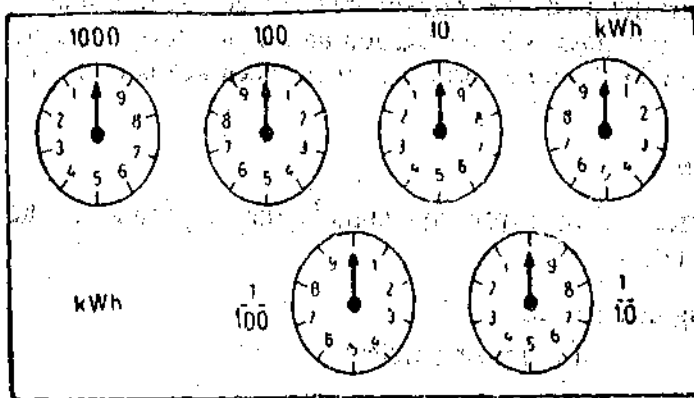

Fig. 11.2. Pointer type of register.

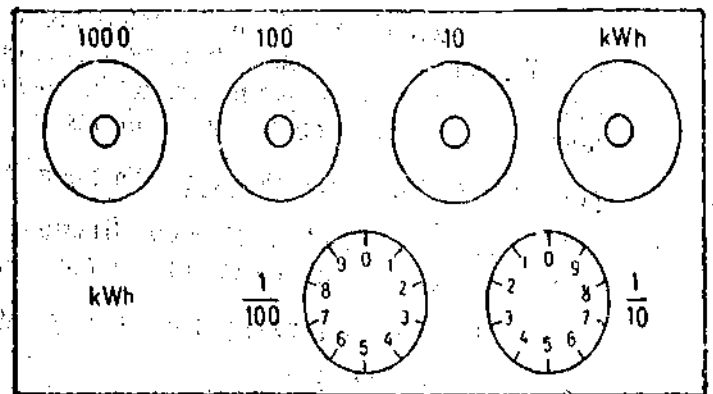

Fig. 11.3. Cyclometer register.

By a suitable system, a train of reduction gears the pinion on the rotor shaft drives a series of five or six pointers. These rotate on round dials which are marked with ten equal divisions. The pointer type of register is shown in Fig. 11.2. Cyclo-meter register as shown in Fig. 11.3 can also be used.

11.8. Theory and Operation. The mode of action of this type of meter is similar to the Ferraris type of instrument as explained on page 270. A simple functional diagram of the

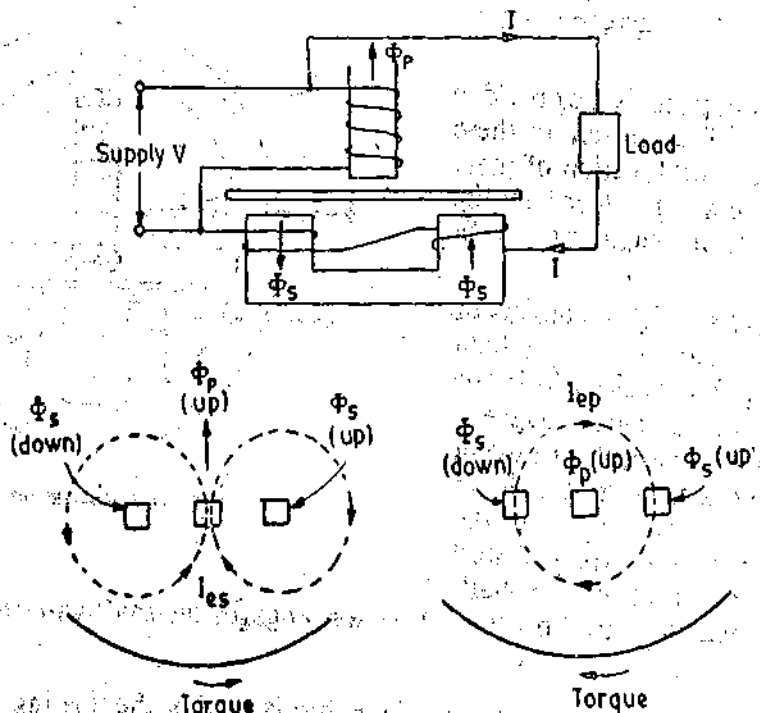

Fig. 11.4. Working of a single phase induction type energy meter.

driving system of the meter is given in Fig. 11'4. The corresponding phasor diagram is given in Fig. 11'5.

The supply voltage is applied across the pressure coil. The pressure coil winding is highly inductive as it has very large number of turns and the reluctance of its magnetic circuit is very small owing to presence of air gaps of very small length. Thus the current I_p through the pressure coil is proportional to the supply voltage and lags it by a few degrees less than 90° . This is because the winding has a small resistance and there are iron losses in the magnetic circuit.

Current I_p produces a flux Φ_p . This flux divides itself into two parts Φ_a and Φ_b . The major portion Φ_a flows across the side gaps as reluctance of this path is small. The reluctance to the path of flux Φ_b is large and hence its magnitude is small. This flux Φ_b goes across aluminium disc and hence is responsible for production of driving torque. Flux Φ_p is in phase with current I_p and is proportional to it. Therefore flux Φ_p is proportional to voltage V and lags it by an angle a few degrees less than 90° . Since flux Φ_p is alternating in nature, it induces an eddy emf in the disc which in turn produces eddy current, I_{ep} .

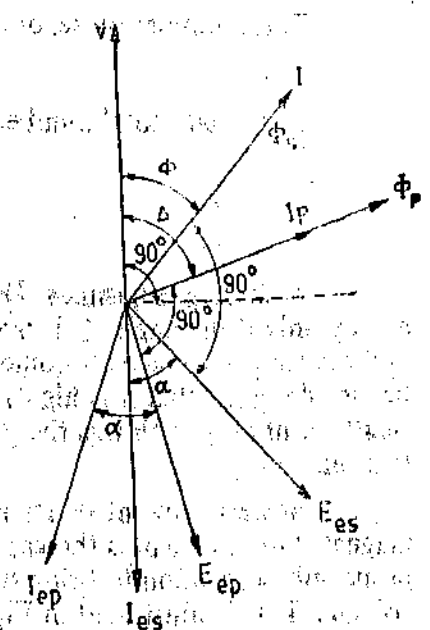

Fig. 11'5. Phasor diagram of single phase induction type energy meter.

The load current I flows through the current coil and produces a flux Φ_s . This flux is proportional to the load current and is in phase with it. This flux produces eddy current I_{es} in the disc. Now the eddy current I_{es} interacts with flux Φ_p to produce a torque and eddy current I_{ep} interacts with Φ_s to produce another torque. These two torques are in the opposite direction (as shown in Fig. 11'4) and the net torque is the difference of these. The theory of induction type instruments has been dealt within details on page 270.

Let V = applied voltage,

I = load current,

ϕ = phase angle of load,

I_p = pressure coil current,

Δ = phase angle between supply voltage and pressure coil flux. f = frequency,

Z = impedance of eddy current paths,

α = phase angle of eddy current paths,

E_{ep} = eddy emf induced by flux Φ_p ,

I_{ep} = eddy current due to flux Φ_p ,

E_{es} = eddy emf induced by flux Φ_s ,

I_{es} = eddy current due to flux Φ_s .

From Eqn. 8'97, net driving torque

$$T_d \propto \Phi_1 \Phi_2 \frac{f}{Z} \sin \beta \cos \alpha = K_1 \Phi_1 \Phi_2 \frac{f}{Z} \sin \beta \cos \alpha$$

where K_1 = a constant.

Now β = phase angle between fluxes Φ_1 and Φ_2 .

In our case, the two fluxes are Φ_p and Φ_s ,

$\therefore \beta$ = phase angle between fluxes Φ_p and $\Phi_s = (\Delta - \phi)$ (See Fig. 11'5)

\therefore Driving torque $T_d = K_1 \Phi_p \Phi_s \frac{f}{Z} \sin (\Delta - \phi) \cos \alpha$

But $\Phi_p \propto V$ and $\Phi_s \propto I$.

$\therefore T_d = K_2 VI \frac{f}{Z} \sin (\Delta - \phi) \cos \alpha$

If f , Z and α are constant, $T_d = K_3 VI \sin(\Delta - \phi)$... (11.7)

If N is the steady speed, braking torque $T_B = K_4 N$.

At steady speed the driving torque must equal the braking torque.

$\therefore K_4 N = K_3 VI \sin(\Delta - \phi)$, $N = K VI \sin(\Delta - \phi)$... (11.8)

If $\Delta = 90^\circ$, $N = K VI \sin(90 - \phi) = K VI \cos \phi$... (11.9)
 $= K \times (\text{power})$.

Thus in order that the speed of rotation is proportional to power, angle Δ should be equal to 90° . Hence the flux Φ_p must be made to lag the supply voltage by exactly 90° .

Total number of revolutions $= \int N dt = K \int VI \sin(\Delta - \phi) dt$... (11.10)

If $\Delta = 90^\circ$, total number of revolutions $= K \int (VI \cos \phi) dt$... (11.11)

$= K \int (\text{power}) dt = K \times (\text{energy})$

11.6. Lag Adjustment Devices. It is clear from Eqn. 11.10 that the meter will register true energy only if the angle Δ is made equal to 90° . Thus the angle between the shunt magnet flux Φ_p and the supply voltage V should be equal to 90° . This requires that the pressure coil winding should be so designed that it is highly inductive and has a low resistance and the iron losses in the core are small. But even with this the phase of flux Φ_p is not 90° with respect to voltage V but a few degrees less than 90° .

However, by introducing a magnetic shunt circuit which allows the main portion of the shunt magnet flux to bypass the gap in which the disc is located, it is possible to introduce an mmf in the proper phase relation to bring the shunt magnet flux in the disc air gap in exact quadrature with the voltage. This is illustrated in Fig. 11.6.

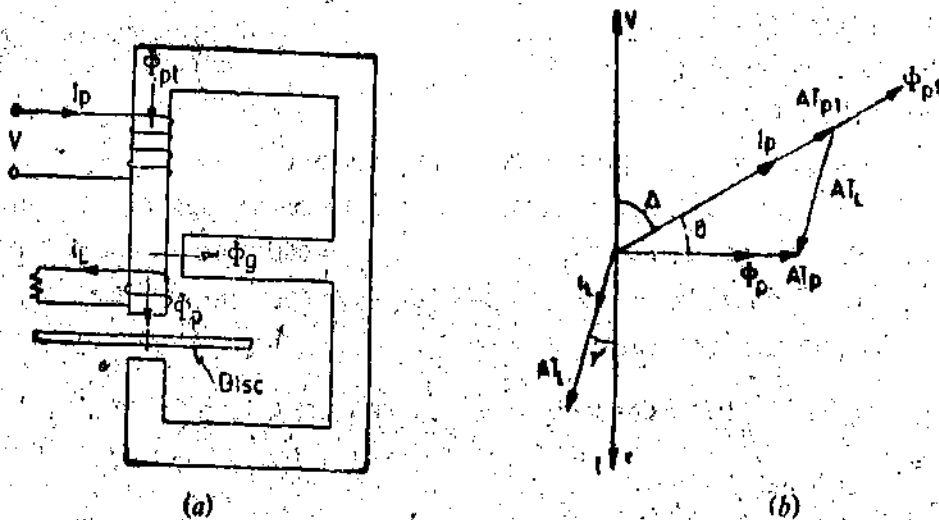

Fig. 11.6. Adjustment of lag angle with "lag coils".

The required mmf is obtained from a 'lag coil' which is located on the central limb of the shunt magnet close to the disc gap and links with the flux that cuts the disc.

The pressure coil is excited by voltage V and carries a current I_p which produces an mmf AT_{pt} which in turn produces a flux Φ_{pt} lagging the voltage by an angle $90^\circ - \Delta$. The flux Φ_{pt} divides itself into two parts Φ_p and Φ_p . Flux Φ_p cuts the disc and also links with the "lag coil". A voltage e_L is induced in this coil lagging Φ_p by 90° . This voltage circulates a current i_L through the lag coil. i_L lags behind e_L by an angle γ which depends upon the reactance and resistance of the lag coil. The lag coil current produces an mmf AT_L . The flux Φ_p in the disc air gap will be

created by the combined action of the main mmf AT_p in phase with I_p and the lag coil mmf AT_L in phase with I_L . Thus the flux Φ_p will be in phase with the resultant mmf AT_p . Hence it is clear that the phase of flux Φ_p can be adjusted by varying the mmf of the shading coil either in magnitude or in phase or both.

The arrangements for adjusting the mmf of the lag coil are:

1. **Adjustable resistance.** A few turns of fairly thick wire are placed around the central limb of the shunt magnet and the circuit is closed through a low adjustable resistance (Fig. 11'7). The resistance of this circuit is altered to adjust the lag angles of flux Φ_p . An increase in resistance decreases the current and mmf in the lag coil and therefore the value of lag angle θ is decreased. The value of lag angle θ is increased by decreasing the resistance of the lag coil circuit. The resistance of the lag coil is so adjusted that Δ becomes equal to 90° .

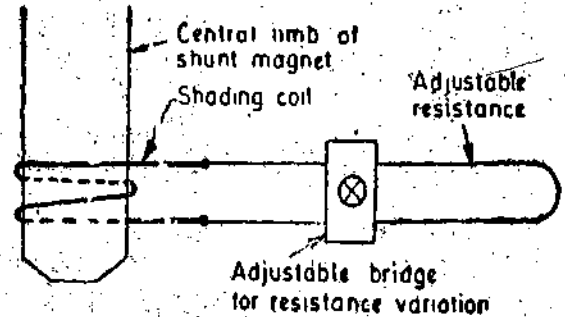

Fig. 11'7. Lag adjustment with adjustable resistance.

2. **Shading bands.** In this arrangement copper shading bands L_1 are placed around the central limb of shunt magnet instead of a lag coil with adjustable resistance (Fig. 11'8). The adjustment can be done by moving the shading bands along the axis of the limb. As the shading bands are moved up the limb, they embrace more flux. This results in greater values for induced emf, current and the mmf AT_L produced by the shading bands and therefore the value of lag angle θ increases. When the shading bands are moved down limb, mmf AT_L decreases and the lag angle is reduced. The adjustment is so done that ' θ ' is such that it makes $\Delta = 90^\circ$.

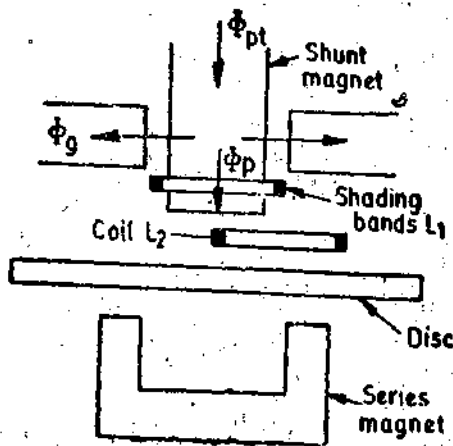

Fig. 11'8. Lag adjustment with change of position of shading bands.

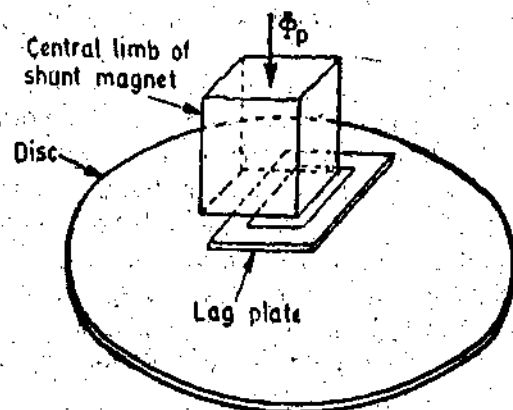

Fig. 11'9. Lag plate.

3. **Lag plate.** In some meters a single-turn lag coil consisting of a punched "lag plate" is used. (See Fig 11'9). The material and cross section of the lag plate are such that appropriate values of impedance, and of mmf are obtained. The lag plate is situated in the air gap directly beneath the central limb of the shunt magnet, and the lag angle is adjusted by moving the plate either radially with respect to the axis of the disc or parallel to the axis of the disc, so that it links with more or less of active shunt magnet flux (Φ_p). Thus its induced voltage and consequently current and mmf are altered.

Hence by providing any of the above arrangements, the shunt magnet flux Φ_p can be brought in exact quadrature with applied voltage V . This adjustment is known as "lag adjustment". Sometimes it is referred to as "power factor", "quadrature" or "inductive load adjustment".

11'7. **Light Load or Friction Compensation.** Despite every care taken in the design of both the jewelled-pivot bearing, which forms the lower bearing for the spindle, and of the simple sleeve or pin-type bearing at the top of the spindle, friction errors are liable to be serious, particularly at light loads. In order to ensure accurate registration at low loads, it is therefore necessary to arrange for a

small torque, practically independent of the load on the meter, which acts in the direction of rotation and which is nearly as possible equal in magnitude to the friction torque. This is usually obtained by means of a small shading loop (or vane) situated between the centre pole of the shunt magnet and the disc and slightly to one side of the centre-line of the pole. This is shown as L_2 in Fig 11.8. The interaction between the portions of the flux which are shaded and unshaded by this loop and the currents they induce in the disc results in a small driving torque whose value can be adjusted by lateral movement of the loop. The tests for correct adjustment are freedom from serious errors at light loads and the value of the load necessary to start the meter. Other arrangements of non-symmetrical shading loops are also used.

In meters provided with lag plates, the additional torque to compensate for the friction can be produced by displacing the plate in a direction parallel to the direction of motion of the disc.

11.8. Creep. In some meters a slow but continuous rotation is obtained even when there is no current flowing through the current coil and only pressure coil is energized. This is called **creeping**. The major cause for creeping is over-compensation for friction. If the friction compensating device is adjusted to give a driving torque to compensate for starting friction which is bigger than the running friction, there is a tendency for the disc to run even when there is no current through the current coils because the friction compensating torque is independent of the load current as the compensating device is voltage actuated. The other causes of creeping are excessive voltage across the potential coil (which is responsible for production of excessive torque by the friction compensating device), vibrations, and stray magnetic fields.

In order to prevent this creeping two diametrically opposite holes are drilled in the disc; the disc will come to rest with one of the holes under the edge of a pole of the shunt magnet, the rotation being thus limited to a maximum of half a revolution. The action may be understood by reference to Fig. 11.10. If a hole is under the edge of a pole, the circular eddy-current paths in the disc will be distorted as shown. The effective centre of the eddy-current paths is then at A' and this point is the central point of the equivalent magnetic pole produced by the currents. Examination of polarities shows that there is a resulting force on the disc, tending to move A' away from the pole axis A . Thus the disc may creep until the hole reaches a position near the edge of a pole, but further movement is opposed by the torque produced in the manner just described. The magnitude of this torque is not sufficient to affect the action of the meter on load.

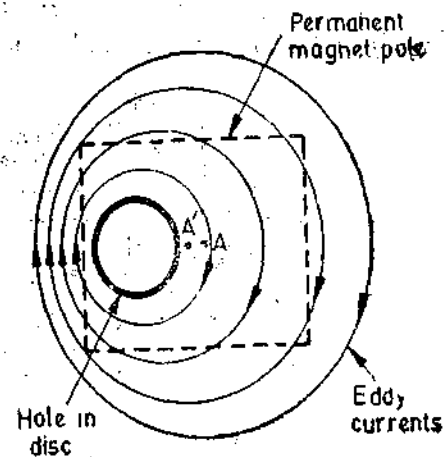

Fig. 11.10. Prevention of creep by drilling holes in disc

In some cases a small piece of iron is attached to the edge of the disc. The force of attraction exerted by the brake magnet on the iron piece is sufficient to prevent creeping of disc.

11.9. Over-Load Compensation. The disc revolves continuously in the field of the series magnet under load conditions and, therefore, there is a dynamically induced emf in the disc because of this rotation. This emf causes eddy currents which interact with the field of the series magnet to produce a braking torque. This self-braking torque is obviously proportional to the square of the load current and it assumes increasing importance as the load rises. Thus at high values of load current the registration tends to be lower than the actual.

In order to minimize the self-braking action, the full load speed of the disc is kept as low as

possible. This speed is nearly 40 rpm. The current coil flux Φ_c is made small as compared pressure with coil flux Φ_p . Thus the dynamically induced emf (which causes the braking torque) is very small as compared with statically induced emf which is produced by flux alterations at the rate of 50 Hz and which is responsible for production of driving torque.

It is customary to add an overload compensating device. This usually takes the form of a magnetic shunt for the series magnet core as shown in Fig. 11.11. The magnetic shunt approaches saturation and so its permeability decreases at overloads. Thus at large currents the magnetic shunt diverts less of series magnet flux, so that a larger portion of the flux appears in the disc air gap and contributes to driving torque.

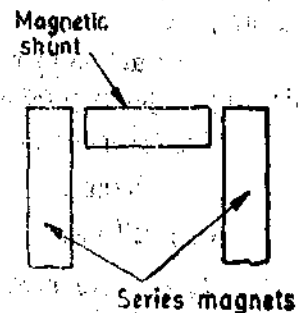

Fig. 11.11. Overload compensation device.

11.10. Voltage Compensation. A certain amount of variation is permitted in the declared voltage of supply. Therefore, energy meters must be compensated for this variation. Voltage variations cause errors owing to two reasons :

(i) The relationship between shunt magnet flux and the supply voltage is not linear owing to saturation in iron parts ;

(ii) The shunt magnet flux Φ_p produces a dynamically induced emf in the disc which in turn results in a self-braking torque which is proportional to square of the supply voltage.

Compensation for voltage variations is provided by using a saturable magnetic shunt which diverts a greater proportion of the flux into the active path when the voltage rises. The compensation can be conveniently provided by increasing the reluctance of the side limbs of the shunt magnet. This is done by providing holes in the side limbs shown in Fig. 11.11.

11.11. Temperature Compensation. An increase in temperature is accompanied by a rise in resistance of all copper and aluminium parts and results in :

(i) a small decrease in the potential coil flux and a reduction in angle of lag between V and Φ_p ,

(ii) a decrease in torques produced by all shading bands,

(iii) an increase in the resistance of the eddy current paths,

and (iv) a decrease in the angle of lag ' α ' of the eddy currents.

If we examine the above effects we find that the errors introduced by variations of temperature of an induction meter are usually small since the various effects produced tend to neutralize each other. An increase in temperature increases the resistance of the pressure coil so that it takes less current resulting in reduced flux of the shunt magnet. This reduces the driving torque. But the flux of the braking magnet is also decreased owing to increase in temperature thereby reducing the braking torque. Again an increase in temperature increases the resistance of the eddy current paths in the disc and this reduces both the driving and the braking torques. Hence these effects tend to neutralize each other. The temperature errors are certainly negligible with non-inductive loads but these errors are quite serious at low power factor loads.

The effect of increase of temperature, in general, is to cause the meter to run fast and to register high. Therefore, the temperature effects can be compensated for by simply using a temperature shunt on the brake magnet. Special magnetic materials, such as 'Mutemp' are available which show a considerable decrease in permeability with increase in temperature.

11.12. Errors. The errors caused by the driving system are :

(i) **Incorrect magnitude of fluxes.** This may be due to abnormal values of current or voltage. The shunt magnet flux may be in error due to changes in resistance of coil or due to abnormal frequencies.

(ii) **Incorrect phase angles.** There may not be proper relationship between the various phasors.

This may be due to improper lag adjustments, abnormal frequencies, change in resistance with temperature, etc.

(iii) **Lack of symmetry in magnetic circuit.** In case the magnetic circuit is not symmetrical, a driving torque is produced which makes the meter creep.

The errors caused by the braking system are :

- (i) changes in strength of brake magnet,
- (ii) changes in disc resistance,
- (iii) self-braking effect of series magnet flux, and
- (iv) abnormal friction of moving parts.

11.13. Adjustments. Some adjustments are carried out in energy meters so that they read correctly and their errors are within allowable limits. The sequence of these adjustments is :

1. **Preliminary Light Load Adjustment.** The disc is so positioned that the holes are not underneath the electromagnets. Rated voltage is applied to the potential coil with no current through the current coil. The light load device is adjusted until the disc just fails to start.

2. **Full Load Unity Factor Adjustment.** The pressure coil is connected across the rated supply voltage and rated full load current at unity power factor is passed through the current coils. The position of the brake magnet is adjusted to vary the braking torque so that the meter revolves at the correct speed within required limits or error.

3. **Lag Adjustment (Low Power Factor Adjustment).** The pressure coil is connected across rated supply voltage and rated full load current is passed through the current coil at 0.5 p.f. lagging. The lag device is adjusted till the meter runs at correct speed.

4. With rated supply voltage, rated full load current and unity power factor, the speed of the meter is checked and full load unity p.f. and low p.f. adjustments are repeated until the desired accuracy limits are reached for both the conditions.

5. **Light Load Adjustment.** Rated supply voltage is applied across the pressure coil and a very low current (about 5 per cent of full load) is passed through the meter at unity power factor. The light load adjustment is done so that the meter runs at correct speed.

6. Full load unity power factor and light load adjustments are again done until speed is correct for both loads *i.e.*, full load as well as light load.

7. The performance is rechecked at 0.5 p.f. lagging.

8. **Creep Adjustment.** As a final check on light load adjustment, the pressure coil is excited by 110 per cent of rated voltage with zero load current. If the light load adjustment is correct, the meter should not creep under these conditions.

11.14. Polyphase Energy Meters. Energy in polyphase circuits can be measured by a group of single phase energy meters connected as required by Blondel's Theorem. The total energy is the sum of the readings of all energy meters (a negative sign is used for the reading of any meter which runs backwards). However, in commercial measurements, the above arrangement is not used but instead polyphase energy meters are used.

Similar to the case of wattmeters for measurement of power in polyphase circuits, the electrical energy in a ' n ' conductor system requires $(n-1)$ measuring elements for measurement of total energy. Thus a 3 phase, 3 wire system requires a 2 element energy meter and a 3 phase 4 wire system requires a 3 element energy meter.

In polyphase wattmeters the elements are mounted on the same spindle which drives the registering mechanism. Thus the registering mechanism registers the net effect of all the elements.

Polyphase wattmeters may be 'multi-disc type' or single disc type. In the multi-disc type, each element drives a separate disc. In the single disc type meter, all the elements drive the same disc. This disc is slotted or laminated in sectors to prevent interaction between eddy currents produced by one element with the flux produced by another element.

11.15. Two Element Energy Meter. Fig. 11.12 shows a 2 element energy meter which is used for 3 phase 3 wire systems. The meter shown in the diagram is provided with 2 discs, one

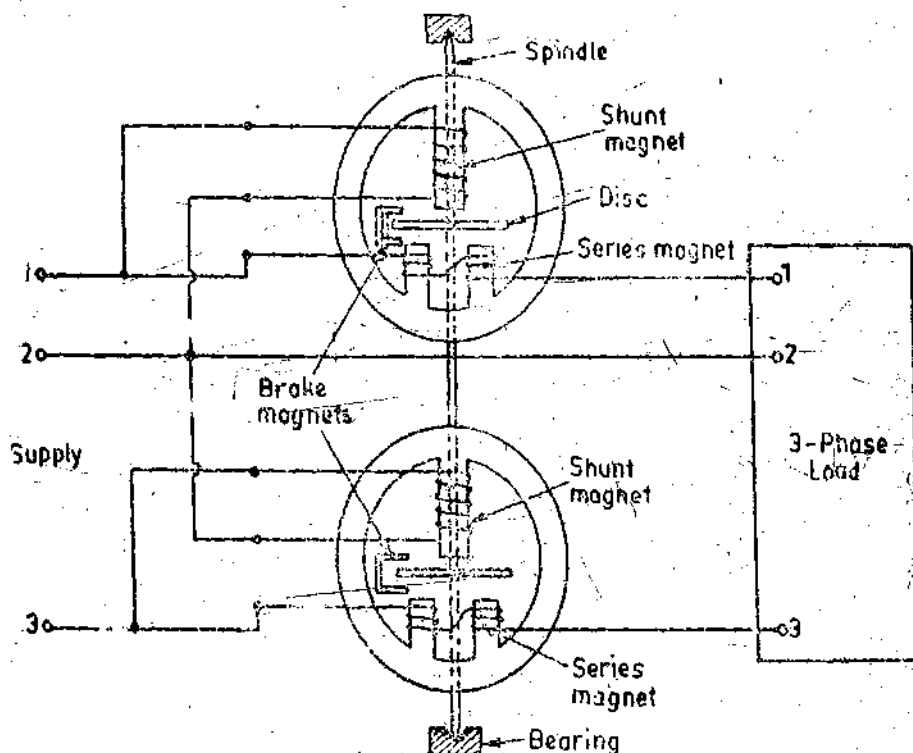

Fig. 11'12. Two element energy meter.

for each element. It is essential that the driving torque of the two elements be exactly equal for equal amounts of power passing through each. Thus in addition to normal compensating devices attached to each element, an adjustable magnetic shunt is provided on one or both the elements to balance the torques of the two. The necessary adjustment is made with the coils energized from a single phase supply. The pressure coils are connected in parallel and the current coils in series in such a manner that the torques produced by the two elements oppose each other. The magnetic shunt is adjusted to a position where the two torques are exactly equal and opposite and therefore there is no rotation of disc. This way the two elements are rendered exactly similar.

The usual lag, light load and unity power factor adjustments are made independently for each element as explained earlier in Art. 11'13.

11'16. Industrial Metering and Tariffs. The rating of a power generating plant must be equal to the simultaneous maximum demand it has to meet. This means that a fixed sum proportional to the maximum demand to be met has to be spent for the plant required. This type of expenses which include the cost of plant, buildings, transmission and distribution equipment, part of staff salaries are called "Fixed Charges". In addition to above, expenses have to be incurred for fuel and also for maintaining the plant. These expenses are proportional to the number of units generated and are called "Running Charges"

Thus if the total cost of electric supply is to be shared equitably by various consumers, every consumer should pay a fixed sum proportional to his maximum demand in addition to a sum proportional to the energy consumed by him.

In a.c. systems the size of the plant is determined not only by the kW capacity required but also by the power factor at which the plant is required to work. Consumers should be encouraged to draw power at high power factors because a system working at low power factor has the following disadvantages :

- (i) Cost of power station and distribution equipment is more for low power factor loads.

(ii) Low power factor makes the regulation poor so that it becomes increasingly difficult to maintain the supply voltage within specified limits.

(iii) The current drawn from the supply by low power factor loads is high. Therefore the loss in the cables, lines and other equipment will be higher at low power factors. Or if the losses are to be kept the same, the sizes of conductors and other equipment will have to be increased.

Tariffs for industrial users should take the above factors into account. There are various types of tariffs which try to balance the costs incurred with the nature of the consumer's load. Some of the industrial tariffs are :

1. **Kilo watt-hour Tariff.** The most straight-forward but not the most usual form, is a charge per kilowatt-hour consumed. Thus the consumer's bill is directly proportional to the energy used. It is also known as "Flat Rate" charge.

2. **Maximum Demand Tariff.** It is a two part tariff. The total charges are divided into two parts, one being simple charge per kilowatt-hour of energy consumed with another fixed charge which is based upon the maximum demand. This maximum demand is actually the average over a predetermined period of time. This period is usually 15 to 30 minutes.

3. **Power factor Tariffs.** Power factor tariffs are devised to make a distinction between overall charge per kilowatt-hour to be recovered from two types of consumers : (i) those having good power factors (who should be charged less) and (ii) those having poor power factors (who should be charged more). Power factor Tariffs are two part type. There are three different types of power factor tariffs :

(i) **kVA Maximum Demand Tariffs.** The maximum demand is measured in kVA and a demand charge per kVA may be recovered in addition to the charges levelled for the energy consumption.

(ii) **Average Power Factor Tariffs.** In this case an average power factor say 0.8 lagging may be assumed as reference and a surcharge for each 0.01 by which the average p.f. falls below this figure (0.8 in our case) may be made. Also, if the average p.f. is above this reference figure, a discount may be allowed in a similar manner.

(iii) **kWh and kVAh Tariffs.** In this type of tariff both kilowatt-hour (kWh) and reactive kilovolt-ampere-hour (kVAh) are separately charged.

The above brief consideration of tariffs is sufficient to show that special meters like maximum demand indicators, reactive kilovolt-ampere hour meters and kilovolt-ampere hour meters have to be installed at industrial establishments in order to have balance between costs of power production with the money recovered from different types of consumers.

11-17. Maximum Demand Indicators. The chief requirement of these indicators is that they shall record the maximum power taken by a consumer during a particular period. The maximum demand indicators shall be so designed that any sudden momentary increase in loads such as due to short circuits on the system or due to high starting currents of motors are not taken into account. Therefore a maximum demand indicator must be designed to record the average power over successive predetermined periods. These periods may be of 15 to 30 minutes duration.

Maximum demand indicators are of four types.

(i) Recording demand indicators. (ii) Average demand indicators (Merz Price maximum demand indicator). (iii) Thermal type maximum demand indicators. (iv) Digital maximum demand indicators.

1. **Recording Demand Indicators.** This meter is recording type watt-meter which records the power drawn at any instant on a chart. The chart can be examined to know the maximum demand of the consumer. This seems simple but the labour required in examination of the chart and the calculation of energy consumed during specified demand intervals is costly and therefore this is normally not used.

2. **Average Demand Indicator (Merz Price Maximum Demand Indicator).** This type of demand indicator is not a separate instrument but is a fitting which can be attached as a unit with any type of energy meter. Thus the maximum demand indicator together with the energy meter

registers the total energy consumption and the maximum value of the average power over equal intervals of time which may be of 15 or 30 minute duration.

Construction and Operation. It consists of a special dial mechanism with a pointer driven forward by a gear train which is normally coupled to the energy meter spindle. This dial system is engaged to the meter spindle for a predetermined time interval say half an hour. After the expiry of this time interval, a reset device comes into operation which brings the mechanism back to zero position. The pointer, however, does not return to zero but is lightly held by a special friction

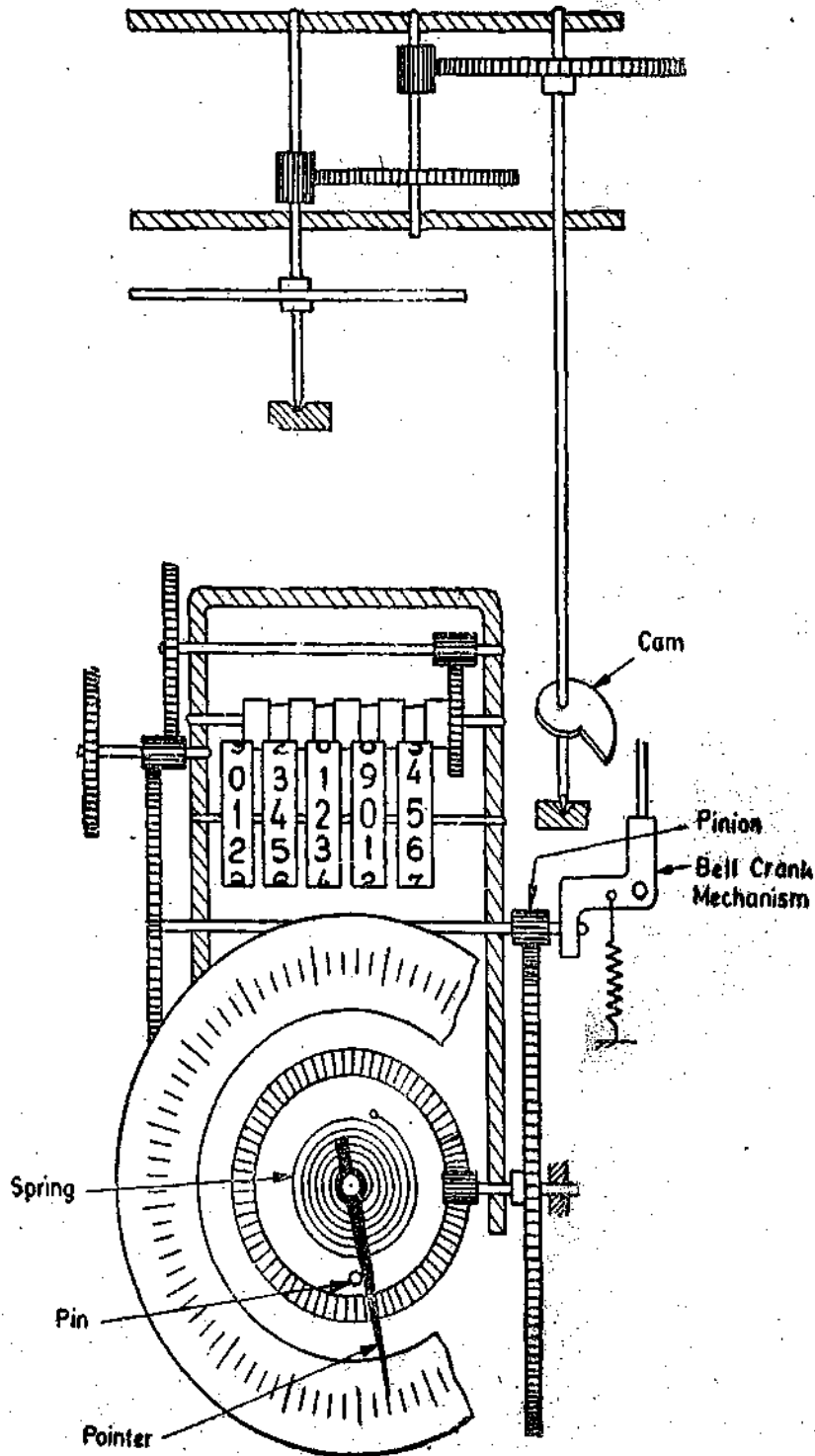

Fig. 11.13. Merz Price Maximum Demand Indicator.

device and continues indicating the energy consumed during the previous half hour. The pointer will not move forward unless the energy consumed in some subsequent time interval exceeds the one recorded by the pointer. In this way the maximum demand expressed in energy consumed per half hour, for any given period of the time is obtained.

The reset device for returning the driving mechanism of the demand indicator to zero at the end of every half hour, is operated by a switch actuated by either a small synchronous motor of the electric clock-type or by an ordinary spring driven clock-mechanism. In some cases the spring of the clock is wound electrically. Duration of the time intervals depends upon the setting of the switch which may be altered as desired.

Fig. 11'13. shows a Merz-Price maximum demand indicator. A pin drives the pointer forward for a period say half hour. The energy consumed during this period is indicated on the dial. At the end of this period a cam controlled by a timing gear momentarily disengages the pinion (as indicated) by means of a bell crank. This allows the driving mechanism and the pin to return to zero position under the action of a spring. The pointer, however, remains at its position and continues recording the energy consumed during the previous half hour period. During the next half hour period the pin is again driven forward, but the pointer is only moved forward if the energy consumed during a subsequent period exceeds that consumed during all previous periods.

There are a number of variations in details of construction. For instance, the cam may be replaced by an electromagnetic relay and a clutch may be substituted for the bell crank releasing device.

The average maximum demand can be calculated by the following simple formula :

$$\text{Average maximum demand in kW} = \frac{\text{maximum energy recorded over a time interval in kWh}}{\text{time interval in hours}} \quad \dots(11'12)$$

Maximum demand meters of this type can also be used to measure the maximum demand in terms of kVAh or kVArh by attaching to a suitable meter element which will measure such quantities.

Advantages. The instrument is more accurate than the thermal type. Its scale is also uniform.

Disadvantages. (i) This meter is costly since it involves mechanisms of great complexity.

(ii) The meter suffers from a serious disadvantage. If the maximum demand occurs sometime after the start of one time interval and continues over only a part of the next interval, the real maximum is not indicated since it is split up into two different time intervals. The thermal lagged meters whose indication does not depend upon preselected times but whose integration is continuous, do not suffer from this disadvantage as they have a very long response time.

3. Thermal lagged Maximum Demand Indicator

Construction. This consists of two similar flat coils of bimetal strips as shown in Fig. 11'14. One is called the actuating coil and the other compensating coil. The actuating coil is surrounded by a heater element which carries the load current or a current proportional to the load current. The two coils are coupled together at their outer ends. The inner end of the actuating coil is fixed and the inner end of the compensating coil carries a needle. This needle moves the maximum demand pointer.

Operation. A bimetal strip is made by welding together, strips of two metals on their flat surface. These metals have different co-efficients of thermal expansion. Thus when a bimetal strip is heated, it will curl up. The direction of curling is towards the metal of lower coefficient of expansion when the temperature is raised, and towards that having the higher co-efficient when the temperature is lowered. Thus curling up with heat is responsible for the operation of a thermal type of maximum demand indicator.

When current passes through the heater element, it heats up the actuating coil causing it to curl. This movement is transferred to the compensating coil (since the two are coupled together) causing the needle to move. The movement of the needle causes the maximum demand pointer to move forward with it. When the current decreases

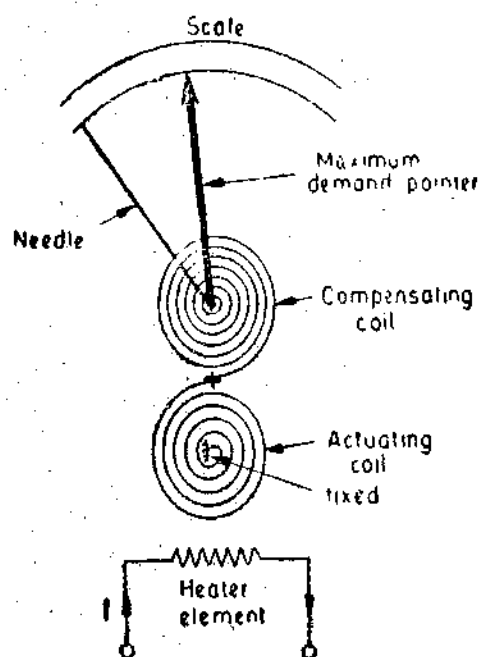

Fig. 11'14. Thermal type maximum Demand (Current or VA) Indicator.

in the heater element, the actuating coil straightens and brings the needle back towards a lower reading but the maximum demand pointer is fixed at its original position by a special friction arrangement. The maximum demand pointer will remain at its position until a larger current than the earlier ones causes it to advance further.

For a given current, the final steady temperature rise of the bimetal strip will not occur instantaneously. The temperature rises slowly in an exponential form to its final steady value. The deflection is proportional to temperature rise which in turn is proportional to the square of current and, therefore, deflection at any instant is :

$$D = K_1 (1 - e^{-K_2 t}) \times I^2 \quad \dots(11.13)$$

K_2 is a function of heat storage capacity of the system.

Hence the meter approaches its final deflection asymptotically and the meter can be so designed that the practical attainment of final steady temperature corresponds reasonably well with the demand interval. Truly speaking the bimetal strip will attain its final steady temperature only at time $t = \infty$ but meters can be designed which attain a temperature which is 99 percent of final steady temperature after an interval of 30 minutes.

The compensating coil is included to prevent changes in air temperature from affecting the demand indicated. An increase in the air temperature will cause both the coils to curl by the same amount and, therefore, if the compensating coil is designed to deflect the needle backwards this will compensate for the forward deflection caused by the actuating coil owing to increase in air temperature. This is known as a differential action.

Advantages. (i) The indicator is suitable for both a.c. and d.c. supplies.

(ii) It is robust, cheap and can withstand momentary heavy overloads.

Disadvantages. (i) When the meter is calibrated in kVA or VA instead of in A, its reading is only correct if the supply voltage remains constant.

(ii) As the deflection is proportional to square of current, the scale is not uniform and is cramped at its lower end. By suitable design, scale can be made fairly uniform down to about one fourth of its full load value.

The meter can be made to read the maximum demand in kW if two bimetallic coils which are heated by currents in two resistors (R, R) of a circuit are used as shown in Fig. 11.15. A small transformer is connected across the line and its secondary supplies to each of the heaters a current Ke where K is a constant and e is the instantaneous line voltage. The instantaneous load current i is taken from the junction point between the heaters so that each heater carries a current $i/2$

Current in heater 1, $i_1 = Ke + i/2$

Current in heater 2, $i_2 = Ke - i/2$.

Heats produced by the heaters are

$$H_1 = (Ke + i/2)^2 R = \left(K^2 e^2 + Kei + \frac{i^2}{4} \right) R$$

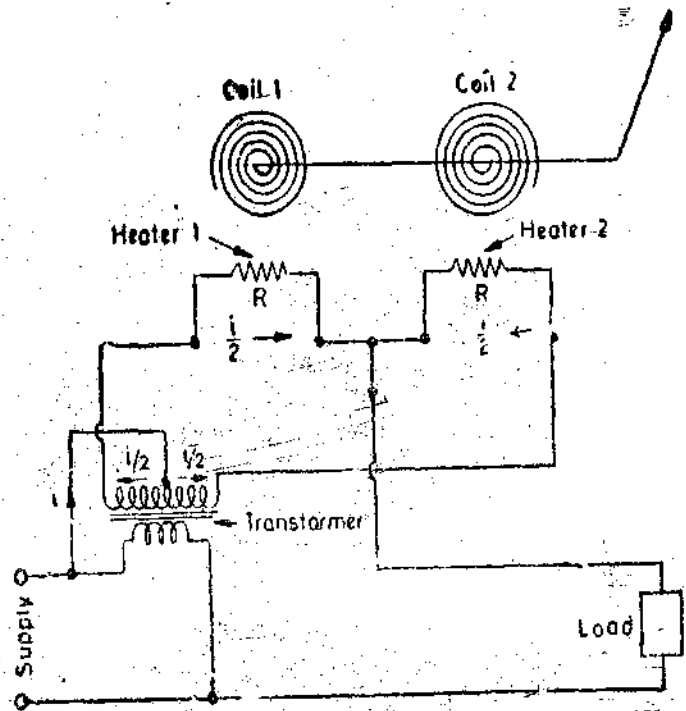

Fig. 11.15. Thermal type maximum demand power indicator.

$$H_2 = (Ke - i/2)^2 R = \left(K^2 e^2 - Kei + \frac{i^2}{4} \right) R.$$

The heats produced by heaters cause the bimetallic coils to curl up and cause deflections. The coils are so connected that they cause deflections in the opposite direction.

Net deflection of the pointer $\propto H_1 - H_2 \propto 2K Rei \propto$ instantaneous power.

Therefore the meter reads the maximum demand directly in W or kW. The rise in temperature is exponential and hence the deflection may be expressed as

$$D = K_1 (1 - e^{-K_2 t}) \times \text{power}.$$

4. **Digital Maximum Demand Indicator.** It has been mentioned earlier that the maximum demand tariff has been used for decades by industrial and other large power consumers. The system has proved itself very useful. It averages the power consumption over specified intervals of time called as Demand Integration Periods. The maximum value of all these measurements is determined and transferred into a cumulative register at the end of a demand integration period which is usually a month. Conventional tariff rate charging devices are rather complicated. They are normally driven by the rotor of an induction type energy meter (as is the case in Merz Price Maximum Demand Indicator) or by a continuously running motor through a servo-mechanism. This has the disadvantage that frequent maintenance is required and its operation is less reliable than that of the meter to which it is attached.

Control Unit with Stores. The block diagram of a digital maximum demand indicator is shown in Fig. 11.16. A substandard meter is used. It incorporates solid state pulse transmitter which scans the disc and sends a pulse frequency proportional to the measured power to maximum demand mechanism. In between, the pulses pass through a pulse shaper (*IF*) and an electronic pulse scaler (*EG*) adapting to the pulse weight to the substandard meter.

The electronic scaler can be used for reducing the pulse ratio down to 1 : 127 or increasing it up to 127 : 1. This allows adaptation to all ordinary meter constants.

The pulses are quantized by the solid state scalar (*EG*) and flow to central processing unit (*CPU*) of the maximum demand mechanism, where they are summated in a store (*SP*₁). They represent, at any time, the instantaneous average power. The period of time during which this summation takes place (15 or 30 minutes) is governed by the demand integration period timer (*MPZ*). After the demand integration period has elapsed, the pulse conditioner (*MP*) and a comparator *V* in the *CPU* draw a comparison between the four digit average power just determined and the four digit value in a store (*SP*₂) which contains the maximum demand value of previous demand integration periods. If the average stored in *SP*₁ of the demand period just completed exceeds that of *SP*₂, the contents of *SP*₁ are transferred to *SP*₂ as the new maximum demand. The contents of store *SP*₁ are then erased and *SP*₂ is employed for determining the next power average. If *SP*₁ is smaller than *SP*₂, the preceding demand integration period does not contain a new maximum demand. The contents of *SP*₂ remain unchanged while the contents of *SP*₁ are erased. The procedures are carried through on completion of each demand integration period. The store contents of *SP*₁ and *SP*₂ can also be read out on a Light Emitting Diode (*LED*) array through switch *S*₁.

At the end of one month, the value recognized to be the maximum demand is transferred from store *SP*₂ and added to a five digit cyclometer register (*K*) and the count of the second three digit cyclometer register (*R*) is increased by the value 1. This second cyclometer register (*R*) counts the number of cumulations. As at the end of a demand integration period is not the end of a month, it is important that before the maximum demand is transferred to 5 digit cumulative register (*K*) the maximum demand ascertained by that time should be again compared with power average of demand integration period in progress. This ensures that the final though not entirely completed power range is included in the maximum demand computation. At the end of the cumulation procedure, the two store contents *SP*₁ and *SP*₂ are cancelled. There are two ways of resetting the maximum demand monthly, that is initiating the cumulation by :

- (i) Hand resetting by changing over switch S_2 .
- (ii) Energization through a ripple control receiver or a solid state monthly resetting timer.

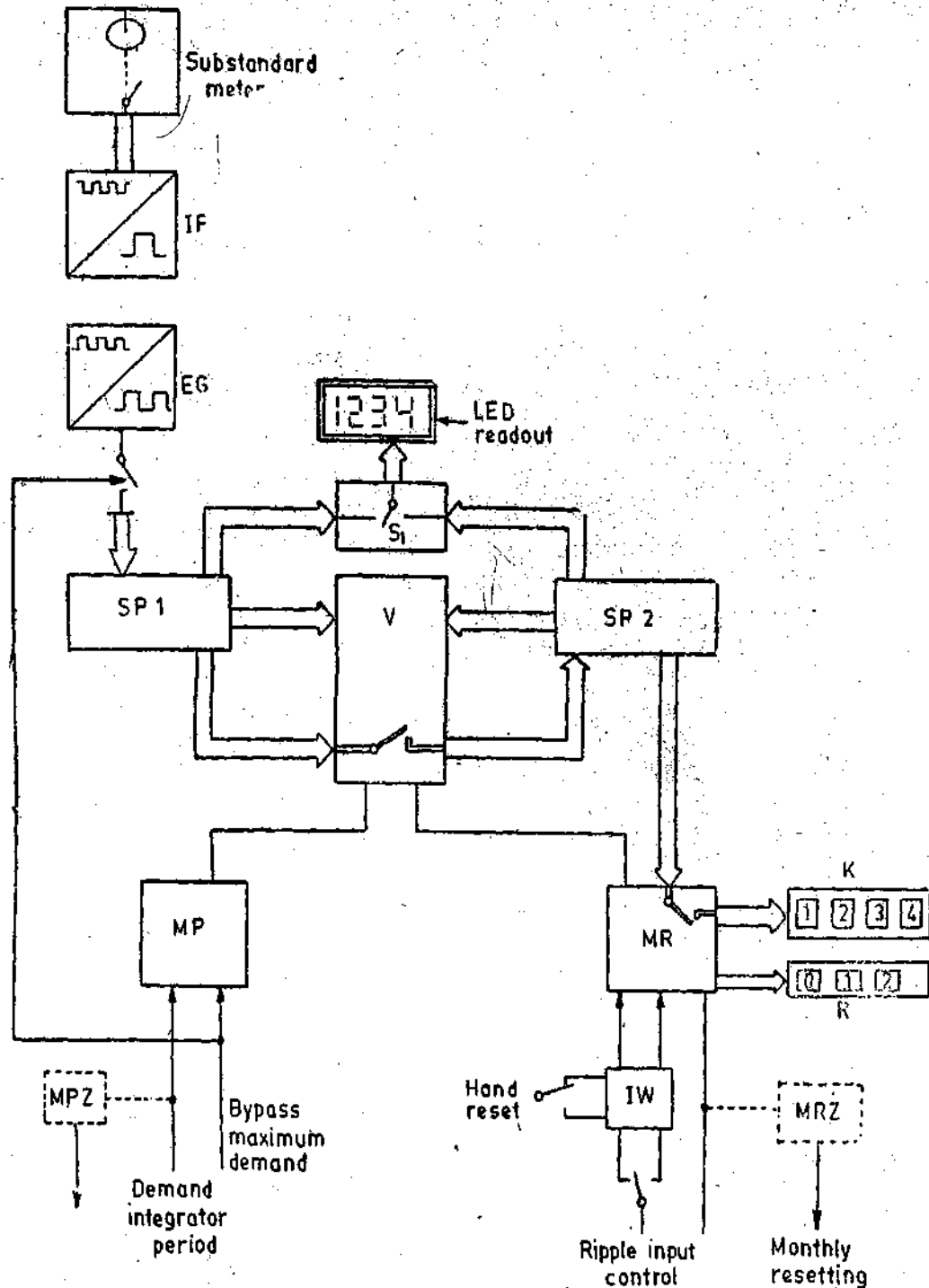

- IF* Pulse shaper
- EG* Solid state descaler
- SP₁* Store for power average
- SP₂* Store for maximum demand
- V* Comparator
- MP* Conditioner for demand integration period pulse
- MPZ* Demand integration period timer
- MR* Monthly resetting pulse conditioner
- MRZ* Monthly resetting timer
- IW* Pulse gate
- K* Commulative register
- R* Register for indicator of number of commutations

Fig. 11'16. Digital maximum demand indicator.

The control input for the maximum demand bypass is so wired and equipped that the maximum demand mechanism measures the maximum demand at definite times only. These times can be set by an external time switch.

Timers MPZ and MRZ

Demand integration period timer (MPZ). The demand integration period timer is designed for 15 or 30 minutes. A 50 Hz timing pulse derived from the mains frequency drives a solid state meter which emits pulses at 1 s intervals. The scaled down pulses operate a second scaler which in turn fixes a 15 or 30 minute demand integration period.

Monthly resetting timer MRZ. The timer is driven by 1 s pulses from the demand integration period timer, scaling the incoming pulses down in such a manner that a pulse is sent out every 730.5 hours.

Power supply. The power supply is through mains via transformer and rectifier. In case of supply failure a Ni Cd battery is used.

Advantages. The advantages of a digital maximum demand indicator are :

- (i) Reaction free scanning of rotor disc.
- (ii) No certification of meter when maximum demand mechanism fails.
- (iii) Measurement throughout the full demand integration period (resetting interval less than 0.0005 s).
- (iv) Four digit readout for instantaneous average power and maximum demand.
- (v) Easy to adjust meter constants.
- (vi) Long service life and high reliability by maintenance free static components.
- (vii) Low power consumption (about 3.5 W).

11.18. Measurement of VAh and VARh. For a circuit with a supply voltage V , load current I and power factor $\cos \phi$, we can write :

$$(VI)^2 = (VI \cos \phi)^2 + (VI \sin \phi)^2$$

Now if both sides of the above equation are multiplied by the quantity h^2 , where h is the time in hours, we have :

$$(VIh)^2 = (VIh \cos \phi)^2 + (VIh \sin \phi)^2 \quad \dots(11.14)$$

$$\text{or } (VAh)^2 = (Wh)^2 + (VARh)^2 \quad \dots(11.15)$$

where VAh=volt-ampere hours, Wh=watt-hours, and VARh=volt-ampere hours reactive.

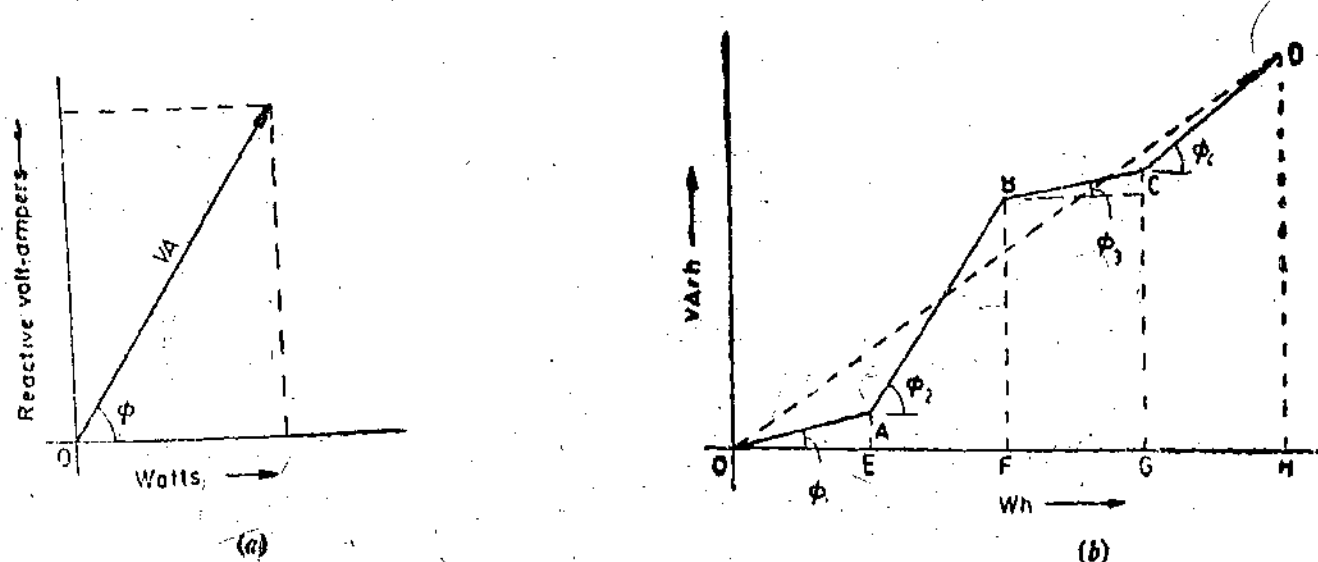

Fig. 11.17

Expressing the above equation in the units encountered in big systems

$$(kVAh)^2 = (kWh)^2 + (kVARh)^2 \quad \dots(11.16)$$

Equations 11'14, 11'15 and 11'16 hold good only for the condition that $\cos \phi$ is maintained constant throughout the time period of h -hours. In practice this condition is usually not met. Let us consider a circuit where the power factor $\cos \phi$ varies irregularly from time to time. If a graph is plotted with watt-hour readings horizontally and reactive volt ampere vertically, the readings being taken at hourly intervals, then at the end of several hours the graph obtained would be somewhat as shown in Fig. 11'17 (b).

At the end of first hour the energy in Wh is OE and VARh is equal to AE and, therefore, the VAh, provided that p.f. $\cos \phi_1$ has remained constant during first hour, is given by OA as :

$$OA = \sqrt{(OE)^2 + (AE)^2}$$

At the end of 2nd hour the total Wh recorded is OF and the total VARh is BF . But the total VAh is not represented by line OB , since the p.f. during second hour is $\cos \phi_2$, which differs from $\cos \phi_1$. The true VAh is given by $(OA+AB)$ which is of course, greater than OB . Thus over a period of four hours [as represented in Fig. 11'17 (b)], the total Wh recorded is OH and the total VARh is DH . If we apply Eqn. 11'15, the total VAh is OD . But the true VAh is not OD but $(OA+AB+BC+CD)$ which is larger than OD .

It is clear that whatever be the shape of lines, between O and D its length can never be less than the straight line OD . Thus if the power factor varies from one instant to the next, even by a small amount the true total VAh is always greater than the value given by expression

$$VAh = \sqrt{(Wh)^2 + (VARh)^2}$$

There will be a further complication in polyphase circuits having unbalanced loads—as in these circuits the active and reactive powers would be different for different phases.

Thus in view of the above considerations, we conclude that the measurement of VAh or kVAh is not a simple matter. Meters required for these measurements are a combination of watt-hour meters and reactive volt-ampere hour meters. Energy (watt-hour) meters have been described earlier and, therefore, we must consider the reactive volt-ampere meters before we go to describe the complicated volt-ampere hour meters.

11'19. VARh Metering. There are three distinct reasons for measuring the reactive kilovolt ampere hours, viz.

- (i) Measurement of VARh is a means of charging bulk consumers for failing to maintain a high power factor.
- (ii) VARh measurement is required for the measurement of VAh.
- (iii) VARh measurement is used as a record of operating conditions when there is an exchange of energy between two or more interconnected power stations.

Integrating meters for registering VARh are usually based upon induction type energy meter element.

Consider Eqn. 11'10 of a single phase energy meter.

The total number of revolutions made in a specified time

$$= K \int VI \sin (\Delta - \phi) dt$$

In case of energy meters angle Δ is made nearly 90° the meter registers the energy consumed. However if, we make $\Delta = 0$ or 180° (by giving an additional quadrature shift) the total number of revolutions in a specified time

$$= K \int VI \sin (0 - \phi) dt = K \int VI \sin \phi dt = K \int (VARh) dt.$$

Thus an induction type energy meter can be converted into a reactive volt-ampere hour meter if the pressure coil flux is brought into phase with the voltage. Hence we conclude that a VARh

meter is an ordinary induction type energy meter with an additional quadrature shift. Several methods are available to achieve the required additional 90° phase shift. The methods employed are :

(i) Special devices are used so as to achieve the requisite phase shifts in the current and voltage circuits.

(ii) Normal energy meters are used but voltages applied have an effective displacement of 90° from those normally applied for energy measurements. This arrangement is particularly suited to polyphase systems.

Normal induction type of energy meters can be used to register VARh with the help of following schemes. These schemes apply to 3-phase 3 wire systems.

(i) **Single Element System.** A normal single phase induction type energy meter is used. The current coil is connected in series with one of the phases while the pressure coil is connected across the other two phases [Fig. 11'18 (a)]. This connection is the same as used for measurement of reactive power.

Total number of revolutions

$$= K \int V_{13} I_2 \cos (90 + \phi) dt = -\sqrt{3} K \int VI \sin \phi dt$$

$$= \sqrt{3} \times K \times (\text{VARh of each phase}).$$

Thus if the system is balanced the meter registers the total VARh. The system suffers from the disadvantage that it can only be used for balanced loads.

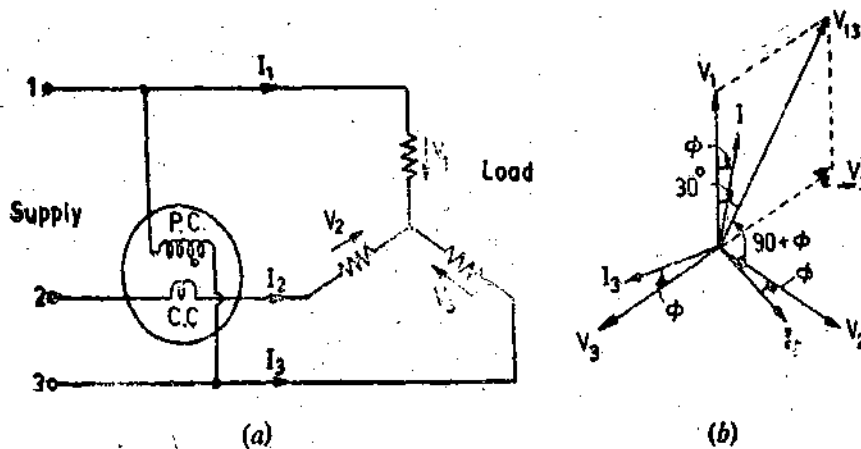

Fig. 11'18. Single element system for measuring VARh in a 3 phase 3 wire system.

(ii) **Crossed Phase Method.** This method can be used for unbalanced currents in a 3 phase 3 wire system. In this case a 2 element polyphase energy meter is used. A neutral point is obtained by means of a choke as shown in Fig. 11'19 (a). Each current is associated with a voltage differing in phase from the voltage normally used for power or energy measurements [Fig. 11'19 (b)]. In this method we must assure that torques acting on the two elements are opposite in direction. Evidently the registration requires a multiplier of value $\sqrt{3}$, since the voltage across the pressure coil is $1/\sqrt{3}$ of that used for power or energy measurements. This is clear from the following :

Total number of revolutions $= K \int [V_3 I_1 \cos (120^\circ + \phi) - V_1 I_3 \cos (120^\circ - \phi)] dt$

Taking a case of balanced currents

Total number of revolutions $= K \int VI [\cos (120^\circ + \phi) - \cos (120^\circ - \phi)] dt$

$$= K \int (\sqrt{3} VI \sin \phi) dt$$

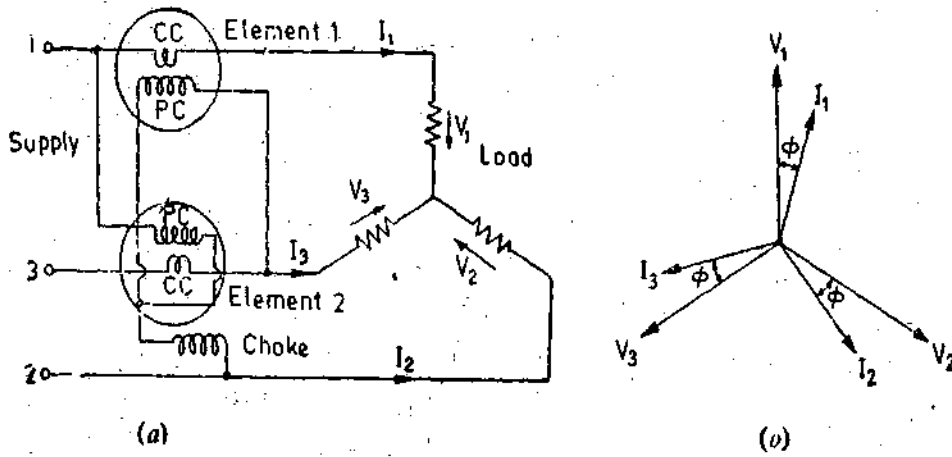

Fig. 11'19. Crossed phase method of metering VARh in a 3 phase 3 wire system.

(iii) Autotransformer Method. This method uses a two element watt hour meter with a phase shifting arrangement employing two open delta connected auto-transformers as shown in Fig. 10'38 page 366. The meter will thus register VARh.

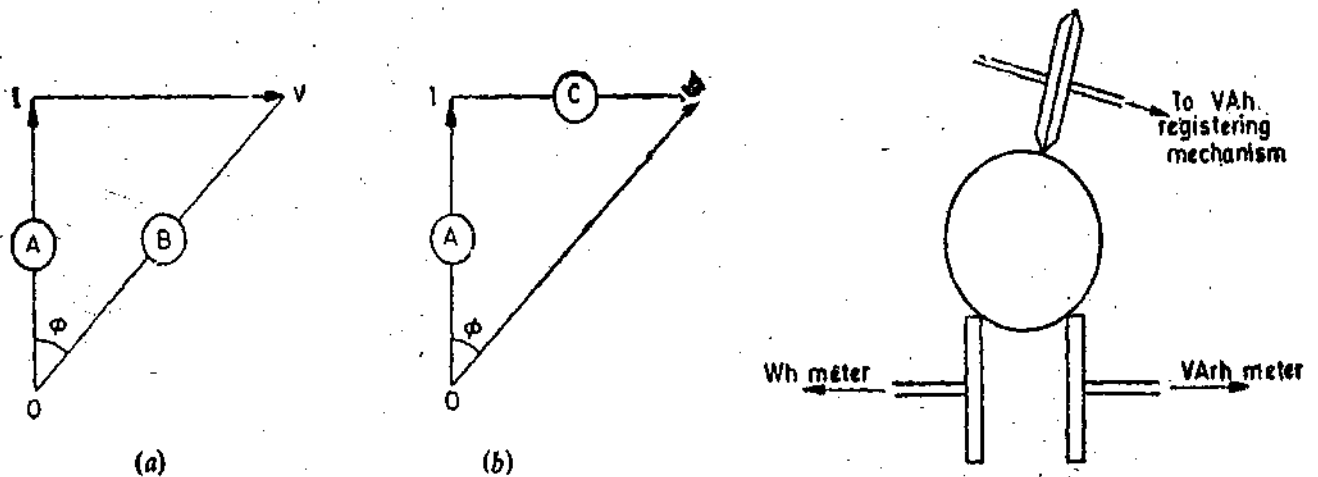

Fig. 11'20. Methods of VAh metering.

Fig. 11'21. VAh metering with ball and disc friction gearing.

11'20. Measurement of VAh. Volt-ampere hours are sometimes measured where the added expense for such measurement is justified. Fig. 11'20 illustrates the two alternative methods of metering volt-ampere hours. *OI* represents the active power *W* and *OV* represents the apparent power *VA*. In Fig. 11'20 (a) meter *A* is the watt hour meter while meter *B* registers the volt-ampere hours. This meter *B* may be maximum demand indicator which gives *VA* demand.

$$VAh = \text{reading of meter } B$$

In Fig. 11'20 (b), *A* is a meter which records watt hours and *C* is a reactive volt-ampere hour meter. The volt-ampere hours may be calculated from these two readings,

$$VAh = \sqrt{(Wh)^2 + (VARh)^2}$$

$$= \sqrt{(\text{reading of meter } A)^2 + (\text{reading of meter } C)^2}$$

This principle of vector addition is utilised for the construction of a meter which measures VAh directly. The action of this meter is based upon an ingenious form of ball and disc friction gearing used to couple three shafts together as shown in Fig. 11'21. Two of these shafts are driven, one by a watt hour meter and the other by a reactive volt-ampere hour meter. Due to the peculiar action of the friction gearing unit, the third shaft takes up a speed proportional to the square root of the sum of the squares of the speeds of the two shafts. Hence the friction gearing sums up the two speeds vectorially in accordance with the following expression :

$$VA = \sqrt{(W)^2 + (VAr)^2}$$

Therefore, the speed of this third shaft is proportional to the VA in the circuit. This shaft is connected to VAh registering mechanism which records the VAh.

Actually it is not very necessary to meter volt ampere hours since the information required is merely for the establishment of an acceptable power factor index for estimating the cost of energy supplied. The power factor does not normally remain constant and, therefore, the average power factor is taken as a power factor index.

$$\text{Average power factor } \cos \phi_a = \frac{Wh}{VAh} = \frac{Wh}{\sqrt{(Wh)^2 + (VArh)^2}}$$

Thus for the arrangement of Fig. 11'20 (a) $\cos \phi_a = \frac{\text{reading of meter A}}{\text{reading of meter B}}$

For the arrangement of Fig. 11'20 (b)

$$\cos \phi_a = \frac{\text{reading of meter A}}{\sqrt{(\text{reading of meter A})^2 + (\text{reading of meter C})^2}}$$

Average power factor is also known as "average energy factor".

2. Trivector Meter This meter measures kVAh and also kVA of maximum demand. The meter consists of a kWh meter and a reactive kVAh meter in the case with a special summator mounted between them. Both the meters drive the summator through a complicated gearing which arranges for the summator to register kVAh correctly at all power factors.

Actually five different gear systems are used:

- (1) Watt-hour meter driving alone at normal speed. This corresponds to unity power factor.
- (2) Watt-hour speed slightly reduced. Reactive meter speed considerably reduced. Corresponding to phase angle $22\frac{1}{2}^\circ$ and power factor 0.925.
- (3) Both speeds reduced by the same factor. Phase angle 45° , power factor 0.707.
- (4) Watt-hour speed considerably reduced, reactive meter speed slightly reduced. Phase-angle $67\frac{1}{2}^\circ$, power-factor 0.38.
- (5) Reactive meter driving alone at normal speed. Power-factor zero.

The final drive from each gear system is taken to a ratchet-coupling linked to a common register shaft. By this means the shaft is always driven by the planet wheel (or direct drive) which has the maximum speed, while all four of the slower shafts merely idle on the ratchets. If the power-factor changes by an appreciable amount then the drive shifts to a different ratchet as a new shaft takes up the fastest running speed. This is shown by the speed/power-factor curves for the two component meters. For a given VI product the speed of the watt-hour meter varies as $\cos \phi$, consequently the curve of 'speed/phase-angle' over a range of $0-90^\circ$ lagging takes the form (1) of Fig. 11'22 while the speed variations of the reactive meter follow curve (5). Thus, if only the two ungeared drives were available, then the speed of the final spindle would follow curve (1) for a range of phase angle variations $0-45^\circ$, but would move to curve (5) for angles $45-90^\circ$. Now taking conditions at the first differential gear the fundamental speeds are reduced by means of suitable gears to give the curves (2') and (2'') for the drive speeds from the two component meters. The planet wheel speed is the sum of these two speed-curves (2'). Similarly curve (3) applies to the second differential gear where the speed reduction ratios are equal, and curve (4) to the third differential where the speed ratios are the same as for curve (2) but in the reverse order. Continuing the resultant speed curves, and bearing in mind the fact that the register drive takes up the fastest ratchet speed, the overall curve (6) is obtained. If the gearing is modified a little to give slightly fast running at the peaks of the curve then the maximum effective error is not more than one or two per cent [curve (7)].

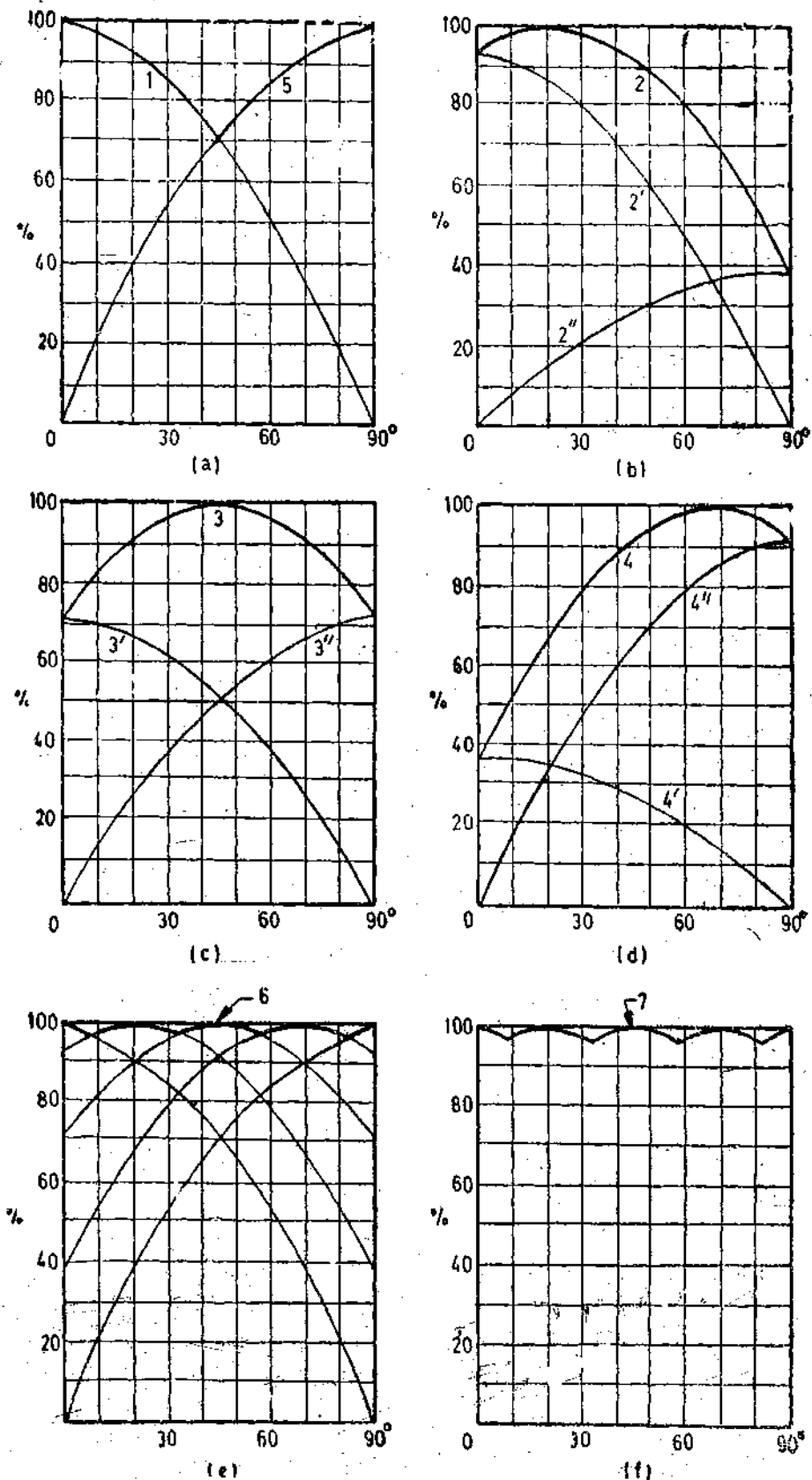

Fig. 11'22

3. **VAn meter using Bridge Connected Rectifiers.** This meter utilizes a 3 phase bridge connected rectifier for summing up the 3 line currents. This meter, therefore, operates satisfactorily on unbalanced loads. The circuit is shown in Fig. 11'23. The three current transformers supply the bridge connected rectifier with currents proportional to the line currents. The components of the direct current I_d due to each of the currents I_1' , I_2' , and I_3' are each independent of the phase of

the corresponding current, so that the total current I_b is a measure of the arithmetic sum of the line currents of the system. This current is passed through the control winding of a transducer, and the alternating current I_c in the output circuit of the transducer (fed from the auxiliary transformer) is proportional to I_b . I_c is passed through the current coil of a conventional induction meter; the voltage circuit is fed from the lines, as shown. The phase angle between pressure coil current I_p and current coil I_c will be constant, so that the meter speed will be proportional to the product of line voltage and I_c , and hence to the product of line voltage and line current as summed by the rectifier.

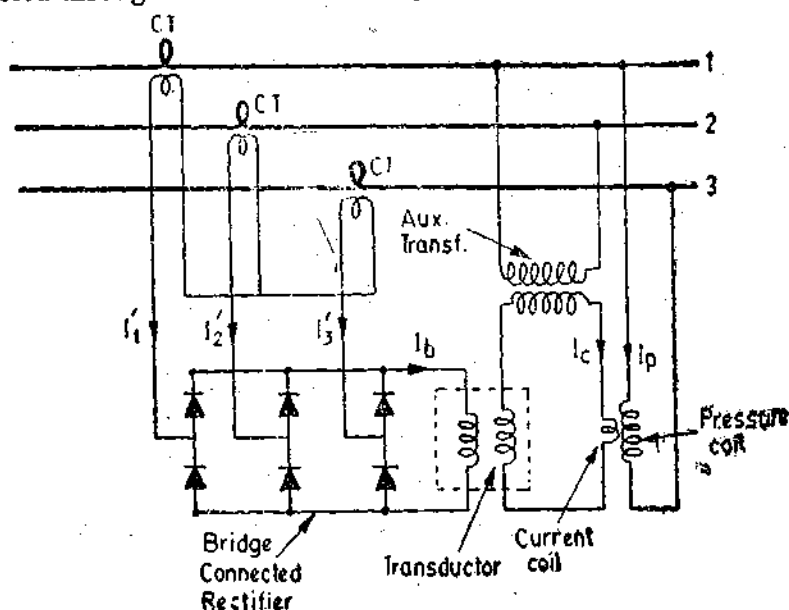

Fig. 11'23. Bridge connected rectifier VAh meter.

ENERGY METER TESTING

11'21. Types of Tests. The term 'testing' includes the checking of the actual registration of the meter as well as the adjustments done to bring the errors of the meter within the prescribed limits.

A.C. Meters. A.C. meters should be tested for the following conditions :

1. At 5 per cent of marked current with unity power factor.
2. At 100 or 125 per cent of marked current with unity power factor.
3. At one intermediate load with unity power factor.
4. At marked current and 0.5 lagging power factor.

In addition meters should be subjected to the following tests :

1. Creep Test. With an applied voltage of 110 percent of its marked value and with the current circuit open, the meter should not revolve through more than one revolution, i.e., it should not creep.

2. Starting Test. At 0.5 per cent of marked value of current and with normal voltage the meter should start and run. Accuracy is not checked at this current.

11'22. Phantom Loading. When the current rating of a meter under test is high a test with actual loading arrangements would involve a considerable waste of power. In order to avoid this "Phantom" or "Fictitious" loading is done.

Phantom loading consists of supplying the pressure circuit from a circuit of required normal voltage, and the current circuit from a separate low voltage supply. It is possible to circulate the rated current through the current circuit with a low voltage supply as the impedance of this circuit is very low. With this arrangement the total power supplied for the test is that due to the small pressure coil current at normal voltage, plus that due to the current circuit current supplied at low voltage. The total power, therefore, required for testing the meter with Phantom loading is comparatively very small. This point is illustrated by the following example.

Example 11'1. A 220 V, 5 A d.c. energy meter is tested at its marked ratings. The resistance of the pressure circuit is 8800 Ω and that of current coil is 0.1 Ω . Calculate the power consumed when testing the meter with

- (i) Direct loading arrangements.
- (ii) Phantom loading with current circuit excited by a 6 V battery.

Solution. The two testing arrangements are shown in Fig. 11'24.

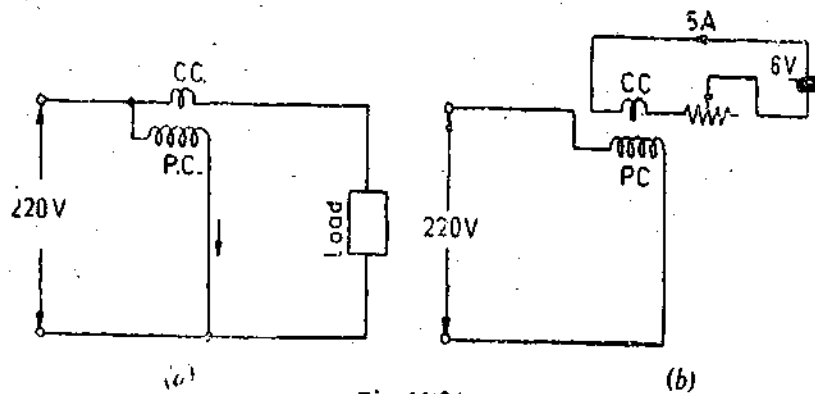

Fig. 11'24

(i) Direct loading :

$$\text{Power consumed in pressure circuit} = \frac{(220)^2}{8800} = 5.5 \text{ W.}$$

$$\text{Power consumed in current circuit} = 220 \times 5 = 1100 \text{ W.}$$

$$\text{Total power consumed} = 5.5 + 1100 = 1105.5 \text{ W.}$$

(ii) Phantom loading :

$$\text{Power consumed in pressure circuit} = \frac{(220)^2}{8800} = 5.5 \text{ W.}$$

$$\text{Power consumed in current circuit} = 6 \times 5 = 30 \text{ W.}$$

$$\text{Total power consumed} = 5.5 + 30 = 35.5 \text{ W.}$$

This power consumption is considerably smaller than the one with direct loading.

11'23. Testing Methods. Three main methods of testing motor meters are given below.

Method A. This method involves a long period Dial test.

Long Period Dial Test. A rotating substandard meter is used to measure the amount of energy passing through the meter being tested in a given time. The current circuits of the two meters are connected in series and thus carry the same current while the voltage circuits are connected in parallel across the same supply. The meters are started and stopped simultaneously. The registrations of two meters are compared at the end of the test period (which is an hour or even more) and the error is calculated as below. Let

D_x = registration of meter under test in kWh,

D_s = registration of sub-standard meter in kWh.

$$\therefore \text{Percentage error} = \frac{D_x - D_s}{D_s} \times 100.$$

This test is called the "long period dial test" and is performed to check the gearing and to ensure that the readings given by registration mechanism are correct.

These tests (as they extend over long periods) give an opportunity of discovering errors due to self-heating. After the end of a long period dial test, a short time test at full load is done to detect the errors caused by heating.

Method B. A rotating substandard meter is used. The current coils of the substandard meter and the meter under test are connected in series, and their pressure coils are connected in parallel. Arrangements are provided to start and stop the two meters simultaneously. This test extends over a short period and therefore it is known as a short period test.

For short periods test

(a) either the revolutions of the test meter disc are compared with those made by the disc of substandard meter during the same time,

(b) or the speeds of the discs of test and substandard meters are directly compared.

Let K_x = number of revolutions per kWh for the meter under test,

K_s = number of revolutions per kWh for the substandard meter.

R_x = number of revolutions made by the meter under test,

R_s = number of revolutions made by the substandard meter during the test interval,

N_x = speed of disc of meter under test,

N_s = speed of disc of substandard meter,

t = time interval in hours.

(a) When revolutions are compared.

Energy recorded by meter under test during test interval = $\frac{R_x}{K_x}$.

Energy recorded by substandard meter during test interval = $\frac{R_s}{K_s}$.

$$\therefore \text{Percentage error} = \frac{(R_x/R_x - R_s/K_s)}{R_s/K_s} \times 100$$

(b) When speeds are compared :

Energy recorded by meter under test = $\frac{N_x t}{K_x}$.

Energy recorded by substandard meter under test = $\frac{N_s t}{K_s}$.

$$\therefore \text{Percentage error} = \left(\frac{N_x K_s}{K_s N_x} - 1 \right) \times 100.$$

An additional requirement of method B is one "long period dial test", extending over an hour at full load. This is done in order to check the registering mechanism and also the effect of time. The meter is then again subjected to a short time test at full load to check for any effect due to heating.

Method C. In this method precision grade indicating instruments are used as reference standard. These indicating instruments are connected in the circuit of meters under test. The current and voltage are held constant during the test. The number of revolutions made by the meter disc during the test are recorded. The time taken is also measured.

Energy recorded by meter under test = $\frac{R_x}{K_x}$ kWh.

Energy computed from the readings of the indicating instrument = kW \times t

where

R_x = number of revolutions made by disc of meter under test.

K_x = number of revolutions per kWh per meter under test,

kW = power in kilowatt as computed from readings of indicating instruments, and

t = time in second.

$$\therefore \text{Percentage error} = \frac{(R_x/K_x - \text{kW} \times t)}{\text{kW} \times t}$$

In addition to this test, a 'long period dial test' is required to check the registration mechanism.

Before conducting any of these tests on a watt hour meter its potential circuit must be connected to the supply for one hour in order to enable the self-heating of the potential coil to stabilise.

11'24. Meter Testing Circuits. These circuits incorporate Phantom loading arrangements. Therefore separate power supplies are used for potential and current circuits. In addition provision must be made for varying the phase of either current or voltage so that the meter can be tested at the desired power factor. A simple circuit for testing single phase induction type meters is shown in Fig. 11'25.

Pressure Circuit Supply. The potential circuit is supplied with the help of an input transformer having an output voltage of 250 V. The primary side this transformer is connected to an auto-transformer which provides fine control of output voltage from 0 to 250 V.

Current Circuit Supply. The current circuit is supplied separately through a transformer. The primary of this transformer is connected to the same supply to which the pressure circuit is connected. The transformer has a tapped secondary and a switch is used to select the tapping which gives the required current. Fine adjustments of current can be done by a variable resistor included in the current circuit.

Phase Shifting Arrangement. Two types of phase shifting arrangements are employed :

(i) The potential circuit is supplied from the secondary of a phase shifting transformer. The primary of this phase shifting transformer is connected to the same supply which feeds the current circuit. The phase of the potential circuit can be varied by rotating the rotor of the phase shifting transformer through an appropriate angle. Arrangement of Fig. 11'25 uses a phase shifting transformer.

(ii) Two similar alternators are coupled together and driven by a motor. One of the alternators supplies the potential circuit and the other supplies the current circuit. One of the alternators is mounted on a cradle so that its stator can be rocked around. Therefore, the position of the stator of this alternator can be changed with reference to the stator of the other alternator. Fig. 11'26 shows an arrangement for phase shifting of alternator supplying the current, the phase of current in the current circuit can be altered with respect to phase of voltage across the pressure coil circuit. The angle through which the alternator stator is moved gives a measure of the phase angle between current and voltage. The frequency of the two currents is the same as the two alternators are identical and are mounted on the same shaft.

When Phantom loading is used an equalizing lead is necessary (Fig. 11'26) in order to ensure that the potential difference between the current and the pressure coils of the meters is zero, as it is when they are in service.

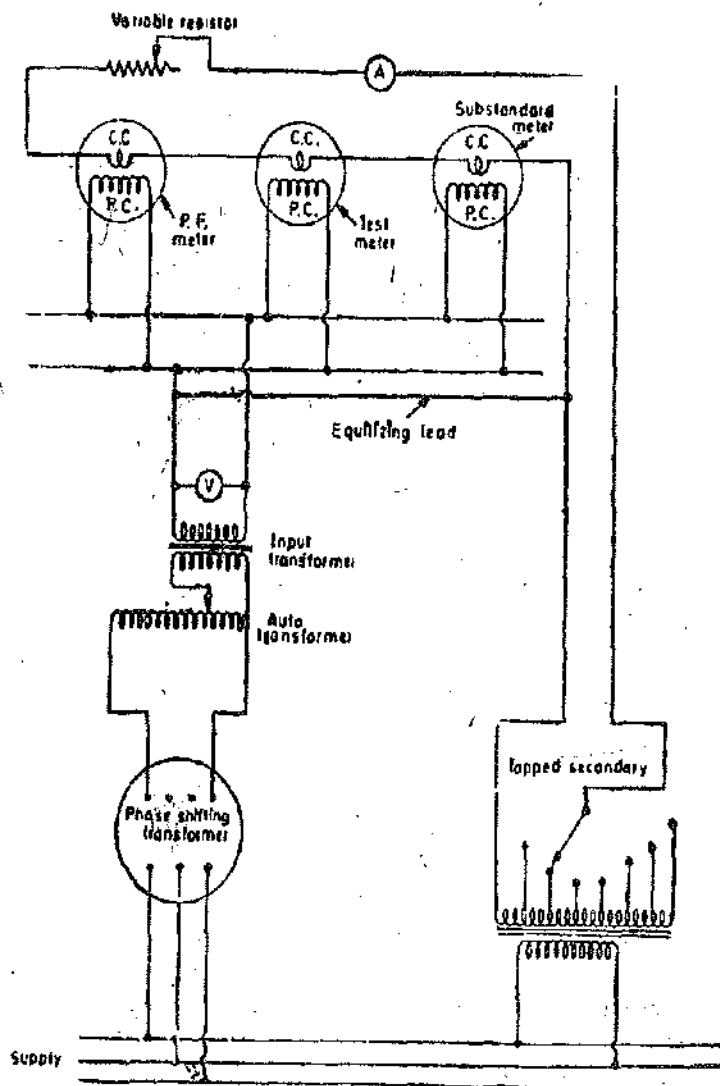

Fig. 11'25. Testing of a.c. meters by Phantom loading (Phase shifting device in the pressure circuit).

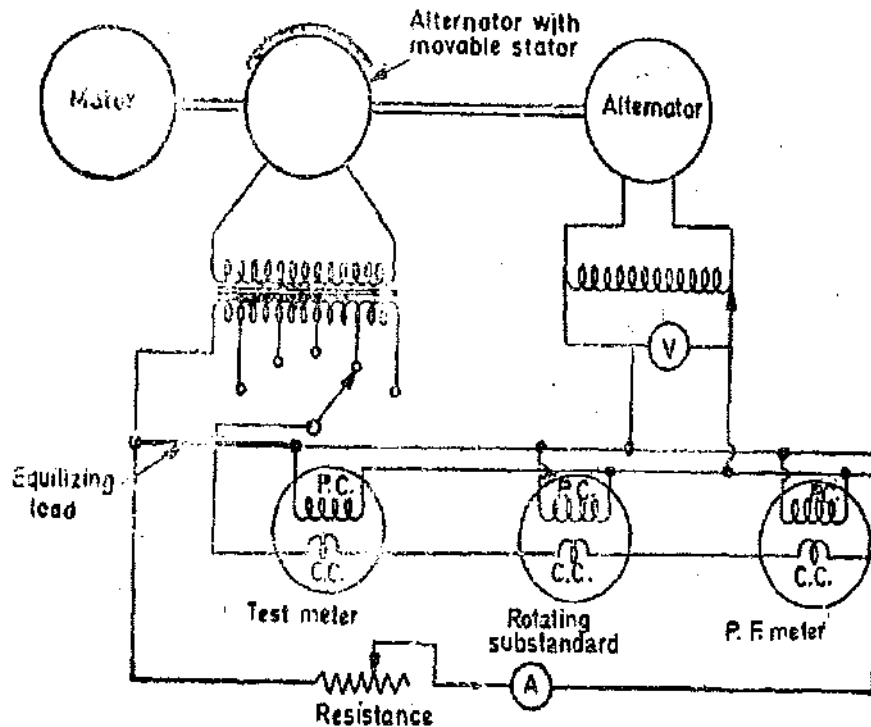

Fig. 11'26. Testing of a.c. meters by Phantom Loading
(Phase shifting device in the current circuit).

Example 11'2. The meter constant of a 230 V, 10 A watt-hour meter is 1800 revolutions per kWh. The meter is tested at half load and rated voltage and unity power factor. The meter is found to make 80 revolutions in 138 s. Determine the meter error at half load.

Solution. Actual energy consumed at half load during 69 s

$$= VI \cos \phi \times t \times 10^{-3} = 230 \times 5 \times 1 \times \frac{138}{3600} \times 10^{-3} = 44.08 \times 10^{-3} \text{ kWh}$$

$$\text{Energy recorded} = \frac{\text{number of revolutions made}}{\text{revolutions/kWh}} = \frac{80}{1800} = 44.4 \times 10^{-3} \text{ kWh}$$

$$\therefore \text{Error} = \frac{44.44 - 44.08}{44.08} \times 100 = 0.817\% \text{ fast.}$$

Example 11'3. An energy meter is designed to make 100 revolutions of disc for one unit of energy. Calculate the number of revolutions made by it when connected to load carrying 40 A at 230 V and 0.4 power factor for an hour. If it actually makes 360 revolutions, find the percentage error.

Solution: Energy actually consumed $= VI \cos \phi \times t \times 10^{-3} = 230 \times 40 \times 0.4 \times 1 \times 10^{-3} = 3.68 \text{ kWh.}$

The meter makes 100 revolutions for one unit i.e. one kWh of energy consumed.

\therefore Number of revolutions made $= 3.68 \times 100 = 368.$

In case the meter makes 360 revolutions, error $= \frac{360 - 368}{368} \times 100 = 2.17\% \text{ low.}$

Example 11'4. The constant for a three phase, 3 element integrating wattmeter is 0.12 revolution of disc per kWh. If the meter is normally used with a potential transformer of ratio 22,000/110 V and a current transformer of ratio 500/5 A; find the error expressed as a percentage of the correct reading, from the following test figures for the instrument only :

Line Voltage = 100 V ; current = 5.25 A ; power factor = 1

Time to complete 40 revolutions = 61 s.

Solution : Actual energy consumed during the test period

$$= \sqrt{3} \times \text{ratio of P.T.} \times \text{ratio of C.T.} \times V_s I_s \cos \phi \times t$$

$$= \sqrt{3} \times \frac{22000}{110} \times \frac{500}{5} \times 110 \times 5.25 \times 1 \times \frac{61}{3600} \times 10^{-3} = 339 \text{ kWh.}$$

Energy recorded by meter during the test period

$$= \frac{\text{number of revolutions made}}{\text{number of revolutions per kWh}} = \frac{40}{0.12} = 333.3 \text{ kWh.}$$

$$\text{Percentage error} = \frac{333.3 - 339}{339} \times 100 = 1.68\% \text{ slow.}$$

Example 11.5. A 230 V, single phase, watt hour meter has a constant load of 4 A passing through it for 6 hours at unity power factor. If the meter disc makes 2208 revolutions during this period, what is the meter constant in revolutions per kWh. Calculate the power factor of the load if the number of revolutions made by the meter are 1472 when operating at 230 V and 5 A for 4 hours.

Solution : Energy supplied = $VI \cos \phi \times t \times 10^{-3} = 230 \times 4 \times 1 \times 6 \times 10^{-3} = 5.52 \text{ kWh.}$

$$\text{Meter constant} = \frac{\text{revolutions}}{\text{kWh}} = \frac{2208}{5.52} = 400 \text{ rev/kWh}$$

$$\text{Energy consumed when the meter makes 1472 revolutions} = \frac{1472}{400} = 3.68 \text{ kWh.}$$

$$\text{Now energy consumed} = VI \cos \phi \times t \times 10^{-3} \quad \text{or } 230 \times 5 \times \cos \phi \times 4 \times 10^{-3} = 3.68.$$

$$\therefore \text{Power factor } \cos \phi = 0.8.$$

Example 11.6. A correctly adjusted, single phase, 240 V induction watthour meter has a meter constant of 600 revolutions per kWh. Determine the speed of the disc, for a current of 10 A at a power factor of 0.8 lagging.

If the lag adjustment is altered so that the phase angle between voltage flux and applied voltage is 86° . Calculate the error introduced at (a) unity p.f. (b) 0.5 p.f. lagging.

Solution : Energy consumed in one minute with rated current and 0.8 p.f. lagging

$$= 240 \times 10 \times 0.8 \times \frac{1}{60} \times 10^{-3} = 0.032 \text{ kWh.}$$

$$\therefore \text{Revolutions made in one minute} = 0.032 \times 600 = 19.2. \quad \therefore \text{Speed of disc} = 19.2 \text{ rpm.}$$

When lag adjustment is altered : Steady speed $N = KVI \sin (\Delta - \phi)$

If the lag adjustment is correctly done $\Delta = 90^\circ$

Under this condition, steady speed $N = KVI \sin (90^\circ - \phi) = KVI \cos \phi$

\therefore Error introduced because of incorrect lag adjustment

$$= \frac{KVI [\sin (\Delta - \phi) - \cos \phi]}{KVI \cos \phi} \times 100 = \frac{\sin (\Delta - \phi) - \cos \phi}{\cos \phi} \times 100 \text{ percent.}$$

We have, $\Delta = 86^\circ$

(a) At unity p.f. $\phi = 0$

$$\therefore \text{Error} = \frac{\sin (86^\circ - 0^\circ) - 1}{1} \times 100 = -0.24\%.$$

(b) At 0.5 p.f. lagging, $\phi = 60^\circ$

$$\therefore \text{Error} = \frac{\sin (86^\circ - 60^\circ) - \sin 60^\circ}{\sin 60^\circ} \times 100 = +12.3\%.$$

Thus it is evident that at low power factors the error due to voltage flux not being in quadrature with applied voltage is very serious even though the phase displacement differs from 90° by a small value of 4° .

Example 11.7. A single phase induction type energy meter is adjusted to read correctly at unity power factor. It is observed that at $1/4$ full load current of 0.5 lagging power factor the effective voltage magnet flux lags behind the current magnet flux by 27° . Will it introduce any error in the measurement? If so, calculate the percentage error introduced.

Solution: Power factor $= \cos \phi = 0.5$ lagging. Phase angle $\phi = 60^\circ$.

Thus the phase angle between applied voltage and load current is 60° . Under ideal conditions, the voltage magnet flux Φ_v should lag behind the applied voltage V by 90° and the current magnet flux Φ_i should be in phase with load current I . This is shown in Fig. 11.27 (a).

$$\text{Energy registered} = K \int VI \sin(\Delta - \phi) dt \propto \sin(\Delta - \phi).$$

Now under ideal conditions $\Delta = 90^\circ$

$$\therefore \text{Energy registered under ideal conditions} \propto \sin(90^\circ - \phi) \propto \cos \phi \propto \cos 60^\circ.$$

The phasor diagram for actual working conditions is shown in Fig. 11.27 (b).

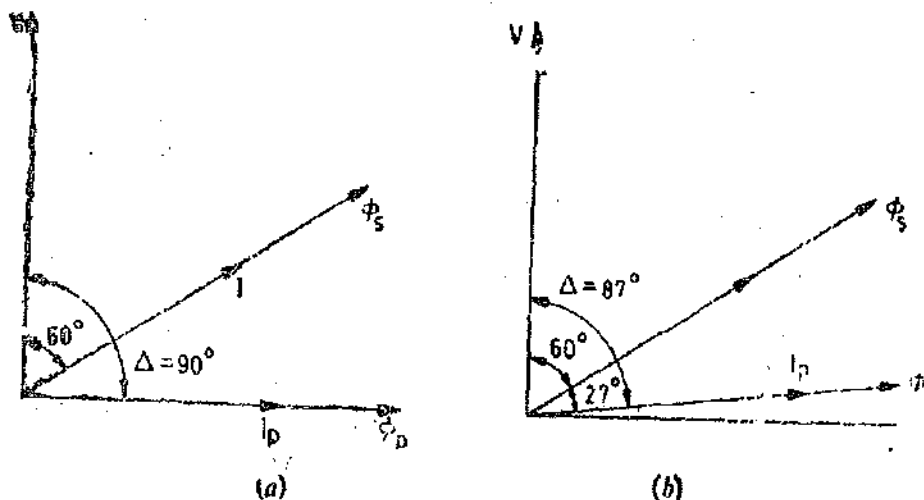

Fig. 11.27

Now $\Delta = 87^\circ$.

\therefore Energy registered under actual working conditions

$$\propto \sin(\Delta - \phi) \propto \sin(87^\circ - 60^\circ) \propto \sin 27^\circ.$$

It is clear from the above that the energy registered under actual working conditions (existing in the meter) is not the same as under ideal conditions. Therefore, the meter does not read correctly.

$$\text{Error} = \frac{[\sin 27^\circ - \cos 60^\circ]}{\cos 60^\circ} \times 100 = \frac{0.454 - 0.5}{0.5} \times 100 = -9.2\%$$

Example 11.8. On investigation a power company found that the polyphase meter through which an industrial plant was being served was incorrectly connected. The error resulted from incorrect polarity markings of one of the potential transformers. During two months the indicated demand had been 400 and 600 kW and the watt hour meter had registered 17000 and 25000 kWh. A careful test showed that power factor was 72 percent most of the time.

(a) By what factor should the demand meter and watt-hour meter readings be multiplied?

(b) The demand charge was Rs. 7.5 per kW per month and the energy charges 5 paise per kWh. Calculate the loss suffered by the company because of the error.

Solution : If the meters are correctly connected :

Torque on element 1 = $KVI \cos (30^\circ + \phi)$ and torque on element 2 = $\sqrt{3} K \cos (30^\circ - \phi)$.

The resultant torque is thus $T_a = KVI [\cos (30^\circ + \phi) + \cos (30^\circ - \phi)] = \sqrt{3} KVI \cos \phi$

where $K = \text{a constant.}$

In case one of the P.Ts. is wrongly connected (i.e., with its polarity reserved) the torque on that element is reserved. Let us consider that the connections on P.T. feeding element 1 is reversed. Therefore, deflecting torques are :

$$\text{Element 1} = K[-VI \cos (30^\circ + \phi)]. \quad \text{Element 2} = KVI \cos (30^\circ - \phi).$$

Therefore, the resultant torque on the meter

$$T_a = KVI [-\cos (30^\circ + \phi) + \cos (30^\circ - \phi)] = KVI \sin \phi.$$

From above it is clear that if one of the P.Ts. is connected with reserved polarity, the meter reads corresponding to a power $VI \sin \phi$ instead of $\sqrt{3} VI \cos \phi$.

$$\therefore \text{ True reading} = \sqrt{3} \frac{\cos \phi}{\sin \phi} \times \text{indicated reading} = \sqrt{3} \cot \phi \times \text{indicated reading.}$$

Hence in order to get true readings, the readings of the meter must be multiplied by a factor $\sqrt{3} \cot \phi$.

$$\text{Now} \quad \cos \phi = 0.72 \quad \text{or} \quad \phi = 44^\circ \quad \text{and} \quad \cot \phi = 1.035.$$

Thus the meter readings must be multiplied by a factor $\sqrt{3} \times 1.035 = 1.8$ in order to get true readings.

Bill of the consumer for two months

$$= 7.5[400 + 600] + \frac{5}{100}[17000 + 26000] = \text{Rs. } 9650.$$

$$\text{True bill} = 1.8 \times 9650 = \text{Rs. } 17370.$$

$$\text{Loss suffered by company} = 17370 - 9650 = \text{Rs. } 7720.$$

Example 11.9. A large consumer has a kVA demand and a kVAh tariff measured by 'sine' and 'cosine' watthour type meters each equipped with a Merz Price demand indicator. The tariff is Rs. 10 per month per kVA of demand plus 4 paise per kVAh. Determine the monthly bill for 30 days based upon the following readings :

'sine' meter advances by 90,000, reactive kVAh demand indicator 150 kVAR, 'cosine' meter advances by 120,000 kWh, and demand indicator 200 kW. What is the average monthly power factor and the total cost per unit ?

Solution : In a month, $\text{kVArh} = 90,000$ and $\text{kWh} = 120,000$.

$$\therefore \text{ Total kVAh in a month} = \sqrt{(\text{kWh})^2 + (\text{kVArh})^2} = \sqrt{(120,000)^2 + (90,000)^2} = 150,000.$$

$$\text{Average p.f.} \quad \cos \phi_a = \frac{\text{kWh}}{\text{kVAh}} = \frac{120,000}{150,000} = 0.8.$$

Now, maximum kVAR demand = 150, and Maximum kW demand = 200.

$$\text{Maximum demand in kVA} = \sqrt{(\text{kW})^2 + (\text{kVAR})^2} = \sqrt{(200)^2 + (150)^2} = 250.$$

$$\text{Monthly bill} = 10 \times 250 + \frac{4}{100} \times 150,000 = \text{Rs. } 8500.$$

$$\therefore \text{ Cost per unit} = \frac{8500}{120,000} \times 100 = 7 \text{ paise.}$$

Example 11.10. The following readings are obtained for one month of 30 days :

kVAhr meter = 83,830, kWh meter = 291,940, Demand indicator = 1400 kW.

Find out the average monthly load factor and power factor.

Solution : Average load over a month

$$= \frac{\text{units consumed in a month}}{\text{number of hours in a month}} = \frac{291940}{30 \times 24} = 405.5 \text{ kW}$$

$$\text{Average monthly load factor} = \frac{\text{average load}}{\text{maximum demand}} = \frac{405.5}{1400} = 0.289.$$

$$\text{Total kVAh in a month} = \sqrt{(\text{kWh})^2 + (\text{kVArh})^2} = \sqrt{(291,940)^2 + (83830)^2} = 303,600.$$

$$\text{Average p.f.} \quad \cos \phi_a = \frac{\text{kWh}}{\text{kVAh}} = \frac{291,940}{303,600} = 0.963.$$

Example 11.11. A 240 V, 5 A, single phase energy meter has a registration constant of 1200 revolutions per kWh. It is tested by means of a 240 V, 5 A wattmeter having 500 scale divisions which can be read to 0.1 division and a stop watch which can be read to 0.01 second and which has negligible error. When tested at full load, the meter makes 40 revolutions in 99.8 s. If the human error in timing be taken as ± 0.05 s, estimate the limits within which the error of the meter may lie. The wattmeter is accurate to within 0.05 percent of its full scale reading.

Solution : Energy registered by the energy meter in 40 revolutions

$$= \frac{40}{1200} \text{ kWh} = \frac{40}{1200} \times 1000 \times 3600 = 120 \times 10^3 \text{ Ws}$$

Power registered by wattmeter at 240 V and 5 A = $240 \times 5 = 1200 \text{ W}$.

Range of wattmeter = 1200 W. Scale divisions = 500.

$$\therefore 1 \text{ scale division} = \frac{1200}{500} = 2.4 \text{ W.}$$

Observational error of wattmeter = $\pm 0.1 \times 2.4 = \pm 0.24 \text{ W}$.

$$\text{Constructional error of wattmeter} = \pm \left(\frac{0.05}{100} \times 1200 \right) = \pm 0.6 \text{ W.}$$

Total error of wattmeter = $\pm 0.24 \pm 0.6 = \pm 0.84 \text{ W}$.

\therefore Wattmeter reading = $1200 \pm 0.84 \text{ W}$.

Observational error of stop watch = $\pm 0.05 \text{ s}$.

Constructional error of stop watch = $\pm 0.01 \text{ s}$.

Total error of stop watch = $\pm 0.05 \pm 0.01 = \pm 0.06 \text{ s}$.

\therefore Reading of stop watch = $99.8 \pm 0.06 \text{ s}$.

Energy obtained from readings of stop watch and wattmeter = $(1200 \pm 0.84)(99.8 \pm 0.06) \text{ W-s}$.

$$\therefore \text{Limits of error of energy meter} = \frac{120 \times 10^3 - \{(1200 \pm 0.84)(99.8 \pm 0.06)\}}{120 \times 10^3} \times 100.$$

Using the positive sign :

$$\text{Percentage error} = \frac{120 \times 10^3 - \{(1200 - 0.84)(99.8 - 0.06)\}}{120 \times 10^3} \times 100 = +0.33\%.$$

Using the negative sign :

$$\text{Percentage error} = \frac{120 \times 10^3 - \{(1200 + 0.84)(99.8 + 0.06)\}}{120 \times 10^3} \times 100 = +0.07\%.$$

UNSOLVED PROBLEMS

1. The declared constant of a 5 A, 220 V d.c. watthour meter is 3275 revolutions per kWh. Calculate the speed of the disc at full load.

In a test run at half load, the meter takes 59.5 s to complete 30 revolutions. Calculate the error of the meter. [Ans. 1 r.p.s., 0.84% fast]

2. A 50 A, 230 V meter on full load test makes 61 revolutions in 37 s. If the normal disc speed is 3200 revolutions per kWh, find the percentage error. [Ans. 0.75% low]

3. A watt hour meter is calibrated to measure energy on a 250 V supply. On test a steady current of 15 A is passed through it 5 hours at unity power factor. If the meter readings before and after the test are 8234.21 kWh and 8253.13 kWh respectively, calculate the percentage error.

If the spindle turns through 290 revolutions during 5 minutes when a current of 20 A is passing through the meter at 250 V and 0.87 power factor, calculate the meter constant. [Ans. 0.9% high; 800 revolutions/kWh]

4. The current and flux produced by series magnet of an induction watthour meter are in phase but there is an angular departure of 3° from quadrature between voltage and the shunt magnet flux. The speed of disc at full load and unity power factor is 40 rpm. Assuming the meter to register correctly under this condition, calculate its speed at $1/4$ full load and 0.5 power factor lagging. Also find the percentage error. [Ans. 4.51 rpm, 9.2%]

5. Two single phase watthour meters are connected through current and potential transformers, to a three phase system. The ratios of the transformers may be considered to be correct, but the phase angle of potential transformers is $15'$ (leading) and that of current transformers $3'$ (leading). The power factor of the system is 0.75 lagging. Determine the relative speeds of the disc. [Ans. 3.2 : 1]

6. A single phase induction watthour meter, tested at its full load rating of 240 V, 10A, is 1% slow at unity power factor and correct at a power factor of 0.5 lagging. Assuming that the friction error is compensated at all power factors, estimate the error at rated VA when the power factor is (i) 0.8 lagging and (ii) 0.8 leading. [Ans. 0.57% slow; (ii) 1.43% slow]

7. Calculate the monthly bill in the case of a consumer whose maximum demand is 120 kW, average monthly load factor is 30 percent, and where tariff in use is Rs. 12 per kW of maximum demand and 3 paise per kWh consumed. [Ans. Rs. 3513.6]

8. A balanced, three-phase delta-connected load on a 400-V, 50-Hz supply has an impedance of $5 + j7 \Omega$ phase. The current coil of a watthour meter W_1 is connected in the line R and that of a watthour meter W_2 in line Y. The volt coils of the two instruments have a common connection on line B, but have their other terminals cross connected, i.e., the volt coil of W_1 is connected to line Y and that of W_2 to line R. Show that the reactive kVAh of the load may be determined from the reading of either watthour meter, and calculate the watthour meter reading and the total reactive kVAh if the time interval is 1 hour. Would the method described apply to an unbalanced load? [Ans. 26.22 kWh; 45.4 kVAh]

9. A rotating substandard energy meter is tested by a wattmeter of the same VA rating having a 500 division scale which can be read to 0.1 division, and a stop watch having a negligible error with a scale which can be read to 0.01 s. The wattmeter is accurate to within 0.05 percent of its full scale reading at all parts of the scale, and the total error in starting and stopping the stop watch does not exceed 0.1 s. Determine the duration necessary for a test of the energy meter at 100 percent load to enable the measured accuracy of the meter to be guaranteed to within 0.1 percent. For a test of the same duration at 10 percent load, calculate limits of accuracy of the determination. [Ans. 370 s; 0.73%]

10. A large consumer has a kVA demand and a kVAh tariff measured by 'sine' and 'cosine' watthour type meters, each equipped with a Merz Price Demand Indicator. The tariff is Rs. 15 per kVA + Re 0.1 per kVAh. Determine the consumer's monthly bill for 30 days based on the following readings: sine meter registers 100 MVAh, demand indicator 125 kVA and cosine meter registers 125 MWh and demand indicator 180 kW. What are the monthly power factor, load factor and average cost per unit? [Ans. Rs. 19280, 0.781, 0.964, Re. 0.154]

Measurement of Phase and Frequency

(Including Synchrosopes and Phase Sequence Indicators)

POWER FACTOR METERS

12.1. Introduction. On measuring the current, voltage and power in an a.c. circuit, its power factor can be calculated from the relationship $\cos \phi = P/VI$.

This method of determining the power factor of an electric circuit is however, of low accuracy, has a number of disadvantages and is rarely used in practice. It is obviously desirable to have an instantaneous indication of the power factor of an a.c. circuit, especially where this is varying continuously, without having recourse to mathematical calculations of readings of several instruments. Power factor meters indicate directly, by a single reading, the power factor of the circuit to which they are connected. The accuracy obtained with the use of power factor meters is sufficient for most purposes other than high precision testing.

Power factor meters—like wattmeters—have a current circuit and a pressure circuit. The current circuit carries the current in the circuit whose power factor is to be measured, or a definite fraction of this current. The pressure circuit is connected across the circuit whose power factor is to be measured and is usually split up into two parallel paths—one inductive and the other non-inductive. The deflection of the instrument depends upon the phase difference between the main current and currents in the two paths of the pressure circuit, *i.e.* upon the power factor of the circuit. The deflection will be indicated by a pointer.

The moving system of power factor meters is perfectly balanced and there are no controlling forces. Hence when a power factor meter is disconnected from a circuit the pointer remains at the position which it occupied at the instant of disconnection.

There are two types of power factor meters :

(i) Electrodynamometer type, and (ii) Moving Iron type.

These instruments are described in details below :

12.2. Single Phase Electrodynamometer Power Factor Meter

Construction. The construction of a single phase electrodynamometer type power factor meter is shown in Fig. 12.1. It consists of a fixed coil which acts as the current coil. This coil is split up into two parts and carries the current of the circuit under test. Therefore, the magnetic field produced by this coil is proportional to the main current. Two identical pressure coils *A* and *B* pivoted on a spindle constitute the moving system. Pressure coil *A* has a non-inductive resistance *R* connected in series with it, and coil *B* has a highly inductive choke coil *L* connected in series with it. The two coils are connected across the voltage of the circuit. The values of *R* and *L* are so adjusted that the two coils carry the same value of current at normal frequency, *i.e.* $R = \omega L$. The current through coil *A* is in phase with the circuit voltage while that through coil *B* lags the voltage by an angle Δ which is nearly equal to 90° . The angle between the planes of coils is also made equal to Δ . There is no controlling device. Connections to moving coils are made by thin silver or gold ligaments which are extremely flexible and thus give a minimum control effect on the moving system.

Theory. In order to simplify the problem, we assume that the current through coil *B* lags the voltage by exactly 90° . Also that the angle between planes of coils is exactly 90° , (*i.e.*, $\Delta = 90^\circ$).

Now, there will be two deflecting torques, one acting on coil *A* and the other on coil *B*. The coil windings are so arranged that the torques due to the two coils are opposite in direction. Therefore the pointer will take up a position where these two torques are equal.

Let us consider the case of a lagging power factor of $\cos \phi$.

Deflecting torque acting on coil *A*

$$T_A = KVI M_{max} \cos \phi \sin \theta \quad (\text{see Eqn. 8.71 page 242})$$

where

θ = angular deflection from the plane of reference

M_{max} = maximum value of mutual inductance between the two coils.

This torque say acts in the clockwise direction.

Deflecting torque acting on coil *B* is :

$$T_B = KVI M_{max} \cos (90^\circ - \phi) \sin (90^\circ + \theta) = KVI M_{max} \sin \phi \cos \theta$$

This torque acts in the anticlockwise direction. The value of M_{max} is the same in the two expressions, owing to similar constructions of the coils.

The coils will take up such a position that the two torques are equal.

Hence at equilibrium $T_A = T_B$

or $KVI M_{max} \cos \phi \sin \theta = KVI M_{max} \sin \phi \cos \theta$ or $\theta = \phi$

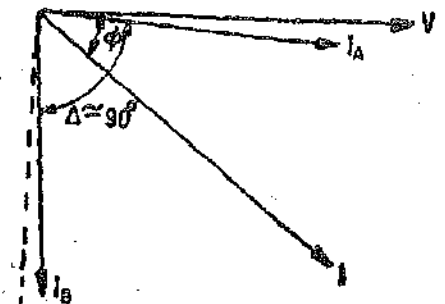
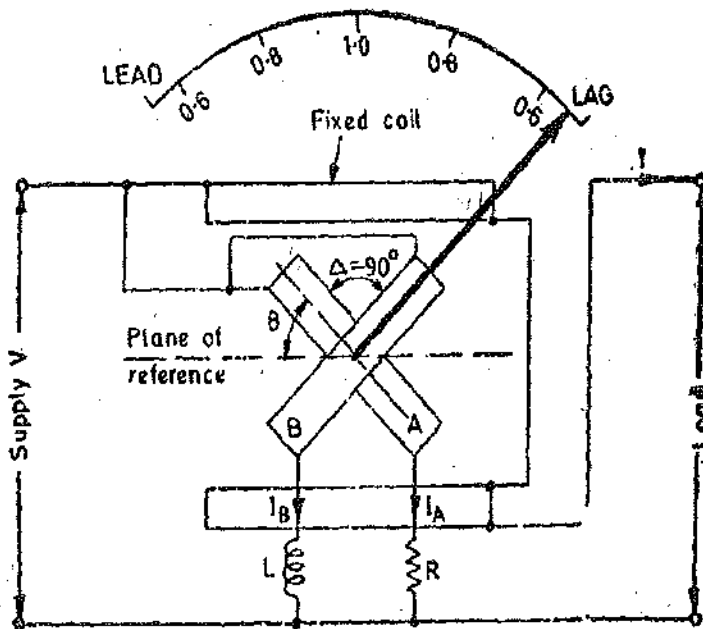

Fig. 12'1. Single phase dynamometer type power factor meter.

Fig. 12'2. Phasor diagram for Fig. 12'1.

Therefore the deflection of the instrument is a measure of phase angle of the circuit. The scale of the instrument can be calibrated in directly in terms of power factor.

The instrument must be designed for, and calibrated at, the frequency of the supply on which it is to be used. In case the meter is used for any other frequency or if the supply contains harmonics it will give rise to serious errors in the indication on account change in the value of reactance of choke coil.

12'3. Three Phase Electrodynamometer Power Factor Meter — Construction. Fig. 12'3 shows the construction and connections of a 3 phase power factor meter. This meter is only useful for balanced loads.

The two moving coils are so placed that the angle between their planes is 120° . They are connected across two different phases of the supply circuit. Each coil has a series resistance. There is no necessity for phase splitting by artificial means, since the required phase displacement between currents I_A and I_B in the two moving coils can be obtained from the supply itself as shown.

Theory. Voltage applied across coil A is V_{12} and as its circuit is resistive, current I_A is in phase with V_{12} . Voltage applied across coil B is V_{13} and current I_B is in phase with V_{13} as the circuit of coil is resistive.

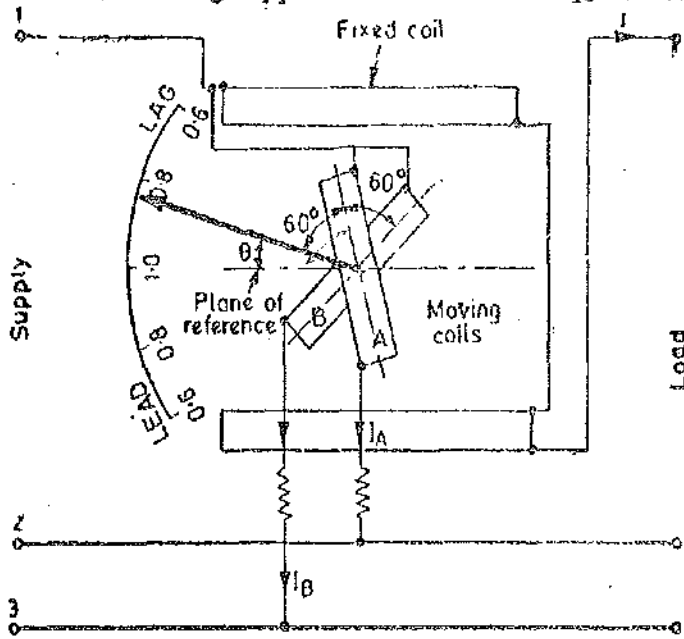

Fig. 12.3. Three phase dynamometer type factor meter.

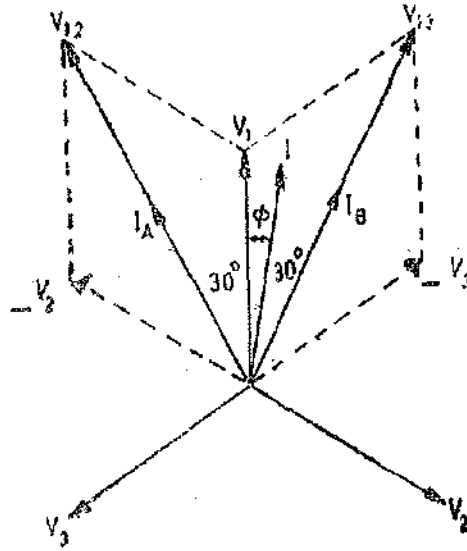

Fig. 12.4. Phasor diagram for Fig. 12.3.

Let ϕ = phase angle of circuit
and θ = angular deflection from the plane of reference

Now $V_1 = V_2 = V_3 = V$.

Torque acting on coil A is :

$$T_A = KV_1 I M_{max} \cos(30^\circ + \phi) \sin(60^\circ + \theta) = \sqrt{3} KVI M_{max} \cos(30^\circ + \phi) \sin(60^\circ + \theta).$$

Torque acting on coil B is :

$$T_B = KV_{13} I M_{max} \cos(30^\circ - \phi) \sin(120^\circ + \theta) = \sqrt{3} KVI M_{max} \cos(30^\circ - \phi) \sin(120^\circ + \theta).$$

Torques T_A and T_B act in the opposite directions and the moving system takes up a position where $T_A = T_B$.

$$\therefore \cos(30^\circ + \phi) \sin(60^\circ + \theta) = \cos(30^\circ - \phi) \sin(120^\circ + \theta)$$

Solving the above expression, we have : $\theta = \phi$.

Thus the angular deflection of the pointer from the plane of reference is equal to the phase angle of the circuit to which the meter is connected.

The three phase power factor meter gives indications which are independent of waveform and frequency of supply, since the currents in the two moving coils are equally affected by any change of frequency.

For measurement of power factor in 3 phase unbalanced systems a two element power factor meter (where 2 sets of fixed coils and 2 sets of moving coils mounted on the spindle) has to be used.

12.4. Moving Iron Power Factor Meters. These instruments may be divided into two categories, according to whether the operation of the instrument depends upon a rotating magnetic field or a number of alternating fields.

12.5. Rotating Field Power Factor Meter. The essential features of a rotating field type of instrument are shown in Fig. 12.5.

A_1, A_2, A_3 are three fixed coils, with their axes displaced 120° from each other and intersecting on the centre line of the instrument. These three coils are connected respectively in lines 1, 2 and 3 of a three phase supply. Usually current transformers are used for the purpose. P is a fixed coil connected in series with a high resistance across one pair of lines say 2 and 3. There is an iron cylinder C inside coil P . Two sector shaped iron vanes V and V' are fixed to this cylinder. The two vanes are 180° apart. The spindle also carries damping vanes and a pointer. There are no control springs.

Theory. Coil P and the iron system produce an alternating flux, which interacts with the fluxes produced by coils A_1 , A_2 and A_3 . This causes the moving system to take up an angular position determined by the phase angle of the current.

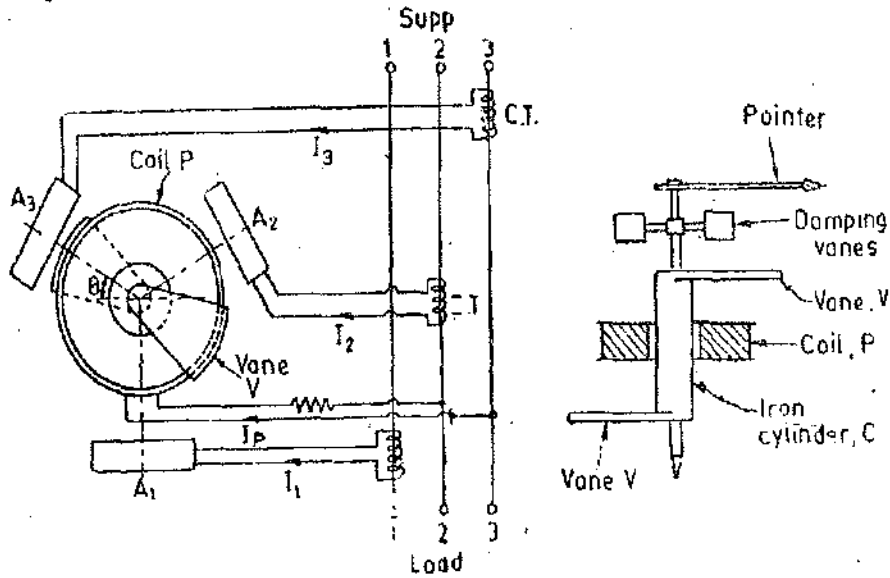

Fig. 12.5. Rotating field moving iron p.f. meter.

The theory of the moving iron instrument may be developed in a similar manner to that of the electro-dynamometer type instruments if we consider the cylinder C and the vanes V, V to be magnetized by current I_p in coil P which is in phase with and proportional to the line voltage of the system. (This is very nearly true as coil P has a large resistance connected in series with it). Then if the effects of hysteresis and eddy currents are ignored, the iron cylinder, the vanes and the coil P are equivalent electromagnetically to a rectangular moving coil pivoted within coils A_1 , A_2 and A_3 , the centre-line of the moving coil being coincident with the axis of the iron vanes.

Fig. 12.6 shows the phasor diagram of the instrument. Now by arguments similar to those used for the electro-dynamometer type of instrument, we can write the expression for total torque acting on the moving system due to currents in coils A_1 , A_2 and A_3 .

The total deflecting torque

$$T_d \propto I_1 I_p \cos(90^\circ - \phi) \sin(90^\circ + \theta) + I_2 I_p \cos(330^\circ - \phi) \sin(210^\circ + \theta) + I_3 I_p \cos(210^\circ - \phi) \sin(330^\circ + \theta).$$

For a steady deflection, the total torque must be zero. Also considering the system to be balanced i.e., $I_1 = I_2 = I_3$, we have

$$\cos(90^\circ - \phi) \sin(90^\circ + \theta) + (\cos 330^\circ - \phi) \sin(210^\circ + \theta) + \cos(210^\circ - \phi) \sin(330^\circ + \theta) = 0$$

Solving the above expression, we have : $\theta = \phi$.

Therefore the deflection of iron vane from the reference axis is a direct measure of the phase angle between each line current and the corresponding phase voltage.

It may be noted that the three fixed coils A_1 , A_2 , A_3 produce a rotating magnetic field and therefore owing to this there will be an induction motor action tending to drag the moving system continuously in the direction of the rotating magnetic field. This effect can be made negligibly small by using high resistivity metal for the moving irons so as to reduce the value of induced currents.

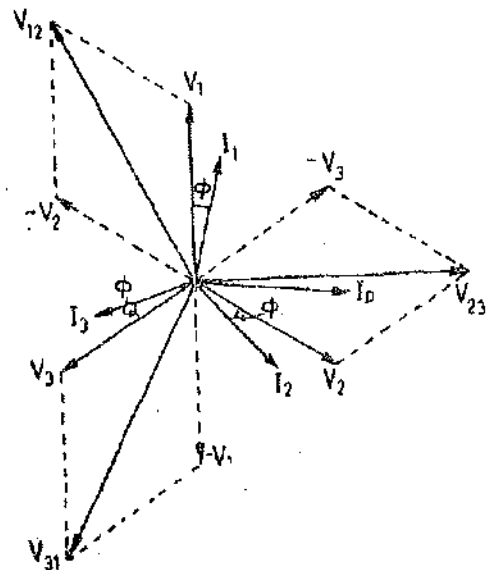
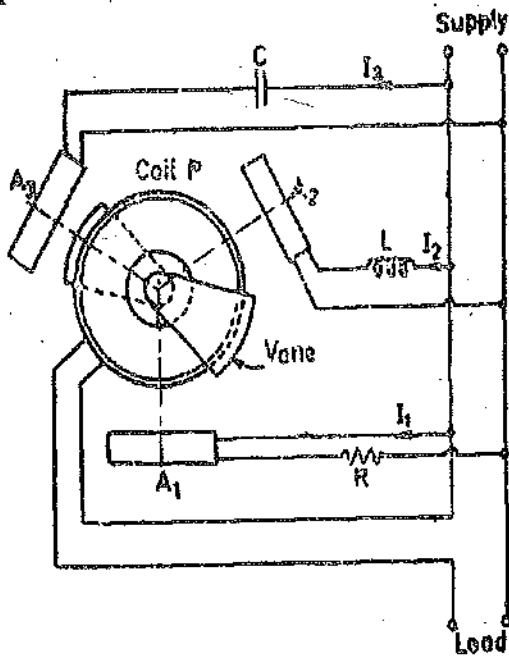
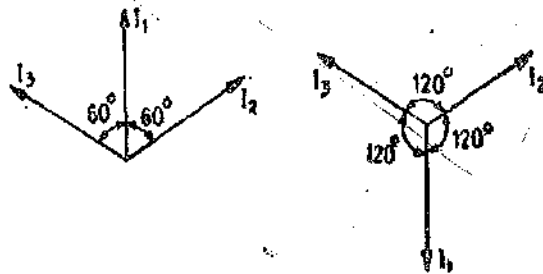

Fig. 12.6. Phasor diagram for Fig. 12.5.

A single phase power factor meter, based upon the principle outlined above is possible if we provide 3 fixed coils displaced by 120° in space. These coils are connected through impedances to the



lines as shown in Fig. 11.7. The values of R , L and C are chosen so that current in coil A_1 is in phase with the line voltage, current in coil A_2 lags by 60° , and current in coil A_3 leads by 60° . The connections of coil A_1 are reversed with respect to the connections of other coils so that the currents in the three coils are 120° out of phase with each other. Coil P is excited by the line current. The rest of the arrangement is similar to that described for the three phase wattmeter. The fixed coil assembly consisting of coils A_1 , A_2 and A_3 has equal currents in each phase displaced 120° in time and since the coil axes are displaced 120° in space a revolving



(i) Before reversal of connections of coil A_1 (ii) After reversal of connections of coil A_1

Fig. 12.7. Single phase moving iron power factor meter.

field is produced which makes the system behave similarly to that for a balanced 3 phase supply.

12.6. Alternating Field Power Factor Meter (Nadler Lipman Type). This instrument is due to Lipman and is manufactured by M/s Nadler Brothers.

Construction. Fig. 12.8 shows the construction of a Nadler Lipman type instrument used for balanced currents. The moving system comprises of three pairs of iron vanes and cylinders which are fixed to a common spindle. This spindle is pivoted in jewel bearings and carries damping vanes and a pointer. The iron vanes are sector shaped, the arc subtending an angle of 120° . The vanes forming each pair (which are magnetically connected to the same iron cylinder) are fixed 180° apart as in the rotating field instrument. The cylinders are separated on the spindle by distance pieces S . These distance pieces are made of a non-magnetic material. The axis of symmetry of the three pairs of vanes are displaced by 120° from each other. The iron cylinders and the vanes are magnetized by three fixed co-axial pressure coils P_1, P_2, P_3 . These pressure coils are mounted co-axially with the spindle and are excited by currents proportional to the phase voltages of the three phase system.

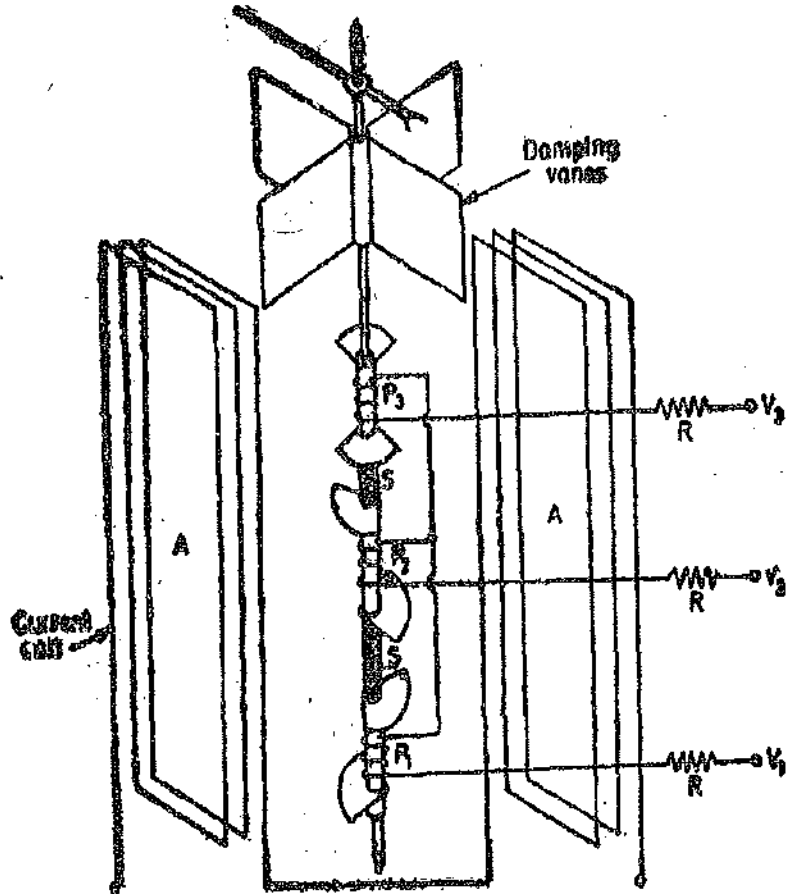

The current coil A , is wound in two equal parts which are mounted

Fig. 12.8. Nadler Lipman power factor meter.

parallel to each other on opposite sides of the spindle. Coil A is supplied with current proportional to the current in one of the lines of the three phase system. There are no control forces.

Theory. The angular position of the moving system is determined by the phase angle of the line current with respect to the phase voltage. The operation of this instrument can be analyzed in a similar manner as used for rotating field type instrument. The rotating field type instrument has three current coils and one pressure coil while the alternating field type has three pressure coils and one current coil. In one case there are three fluxes due to three line currents, displaced from each other by 120° in space as well as in time; together with a flux due to line voltage. In the second case there are three fluxes due to three phase voltages, displaced by 120° in space as well as in time together with a flux due to a line current. Thus the relationship between angular deflection of the moving element and phase angle of the system is the same in both the cases.

The moving system deflects into such a position that the mean torque on one pair of vanes is neutralized by the other two torques, so that the resultant torque is zero. In this steady position, the deflection of the iron vane which is magnetized by the same phase as the current coil, is equal to the phase angle of the circuit. (Provided effect of iron losses and the pressure coil inductance is neglected). The instrument as shown is used for balanced currents, but it can be modified for use on an unbalanced three phase circuit and for two phase and single phase circuits.

It may be noted here that the three coils together with their vanes and cylinders lie in three different planes and therefore no rotating magnetic field is produced. Hence in this instrument there is no tendency for the moving system to rotate continuously as is the case in rotating field type instrument

12.7. Advantages and Disadvantages of Moving Iron P.F. Meters

Advantages. (1) The working forces are very large as compared with those in dynamometer type.

(2) All the coils in a moving iron instrument are fixed and therefore the use of ligaments is eliminated.

(3) The scale extends over 360° .

(4) These instruments are simple and robust in construction. They are comparatively cheap also.

Disadvantages. (1) Errors are introduced in these meters owing to losses in iron parts. These losses are dependent upon the load and the frequency. They are less accurate than the dynamometer type.

(2) The calibration of these instruments is appreciably affected by variations in supply frequency, voltage and waveform.

FREQUENCY METERS

Yes

12.8. Types of Frequency Meters

The different types of frequency meters are :

- Yes —
- | | |
|--------------------------------|--------------------------------|
| 1. Mechanical resonance type ; | 2. Electrical resonance type ; |
| 3. Electrodynamometer type ; | 4. Weston type ; |
| 5. Ratiometer type ; | 6. Saturable core type. |

The frequency can also be measured and compared by other arrangements like electronic counters, frequency bridges, stroboscopic methods and cathode ray oscilloscope.

12.9. Mechanical Resonance Type Frequency Meter (Vibrating Reed Type)

Construction. This meter consists of a number of thin steel strips called reeds. These reeds are placed in a row alongside and close to an electromagnet as shown in Fig. 12.9. The electromagnet

has a laminated iron core and its coil is connected in series with a resistance, across the supply whose frequency is to be measured.

The reeds are approximately about 4 mm wide and 1/2 mm thick. All the reeds are not exactly similar to each other. They have either slightly different dimensions or carry different weights or flags at their tops.

The natural frequency of vibration of the reeds depends upon their weights and dimensions. Since the reeds have different weights and sizes, their natural frequencies of vibration are different. The reeds are arranged in ascending order of natural frequency, the difference in frequency is usually 1/2 Hz. Thus the natural frequency of first reed may be 47 Hz, of the second 47.5 Hz, of the next 48 Hz and so on.

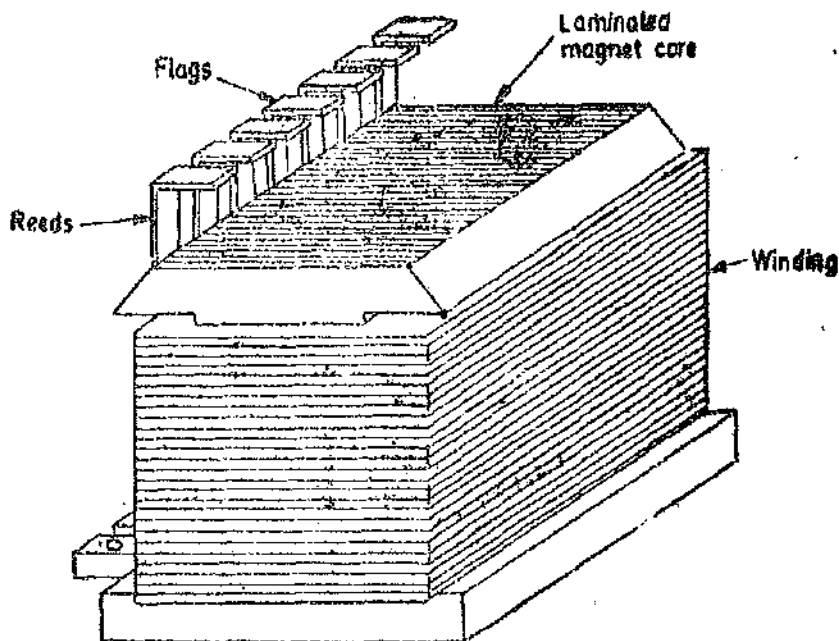

Fig. 12'9. Vibrating reed type frequency meter.

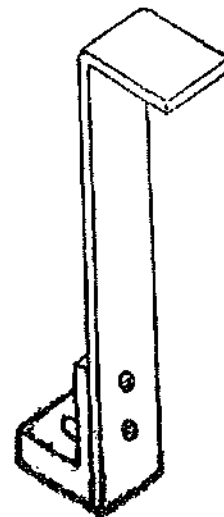

Fig. 12'10. Reed of mechanical resonance frequency meter.

The reeds are fixed at the bottom end and are free at the top end. Since the reeds on a frequency meter are arranged to be viewed end on, they have a portion bent over at the free end to serve as a flag as shown in Fig. 12'10. The flags are painted white to afford maximum contrast against their black background.

Operation. When the frequency meter is connected across the supply whose frequency is to be measured, the coil of electromagnet carries a current i which alternates at the supply frequency. The force of attraction between the reeds and the electromagnet is proportional to i^2 and therefore this force varies at twice the supply frequency.

Thus the force is exerted on the reeds every half cycle. All the reeds will tend to vibrate, but the reed whose natural frequency is equal to twice the frequency of supply will be in resonance and will vibrate most. Normally the vibration of other reeds is so slight as to be unobservable. The tuning in these meters is so sharp that as the excitation frequency departs from the resonant frequency the amplitude of vibration decreases rapidly becoming negligible for a frequency perhaps 1 to 2 percent away from resonance. This is clear from Fig. 12'11.

When the 50 Hz reed is vibrating with its maximum amplitude (when it is in resonance) some vibrations of 49.5 Hz and 50.5 Hz reeds may be observed as shown in Fig. 12'12 (b) but very little vibrations will be observed on 49 Hz and 51 Hz reeds. For a frequency exactly midway between that of the reeds, both will vibrate with amplitudes which are equal in magnitude, but considerably less than the amplitude which is at resonance. Fig. 12'12 (c) shows the condition of vibrating reeds when

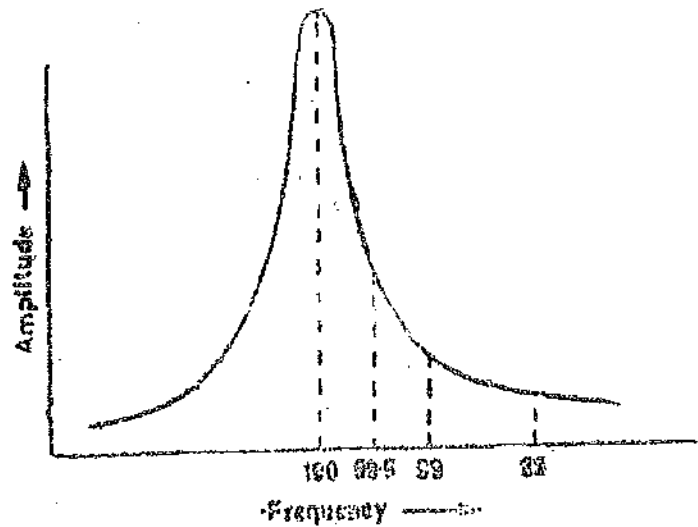

Fig. 12'11. Variation of amplitude of vibrations with frequency.

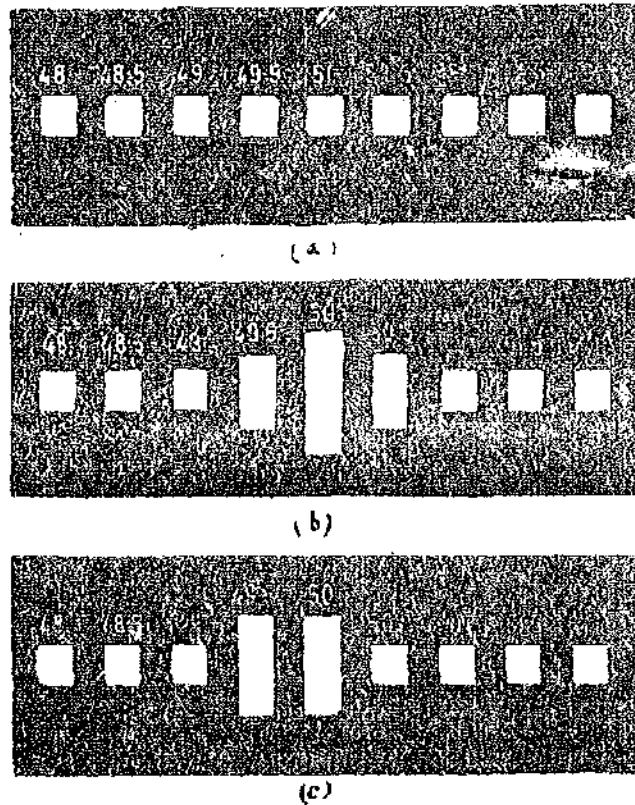

Fig. 12'12. Indications from vibrating reeds.

the frequency is exactly midway between 49.5 Hz and 50 Hz. Fig. 12'12 (a) shows the condition of the reeds when the frequency meter is unexcited *i.e.* is not connected to the supply.

Frequency Range. The usual frequency span of these meters is six Hz say 7 Hz to 53 Hz. The frequency range of a set of reeds may be doubled in a simple manner. In the presence of an alternating flux alone, the reeds are attracted two times in a cycle and the reed whose frequency is twice the frequency of supply responds. If, however, the electromagnet is polarized by a direct flux superposed on the alternating flux and is equal in magnitude, the fields (d.c and a.c.) will cancel each other in one half cycle and reinforce during the other half cycle and so the reeds will be attracted only once in a cycle. Thus a reed whose natural frequency is 100 Hz will respond to 50 Hz when the electromagnet is unpolarized and to 100 Hz when the electromagnet is polarized. It is clear from above that the range of the frequency meter will be doubled with polarization.

The polarization may be accomplished by using a d.c. winding in addition to the a.c. winding or by using a permanent magnet.

Advantages and Disadvantages. An advantage of the reed type of frequency meter is that the indication is virtually independent of the waveform of the supply voltage. The indication is independent of magnitude of applied voltage also provided the voltage is not too low, as at low voltages the amplitude of vibrations will not be sufficient and thus the readings will not be reliable.

The disadvantage is that such instruments cannot be read much closer than half the frequency difference between adjacent reeds. Thus they cannot be used for precision measurements. The reliability of readings also depends upon the accuracy with which the meter reeds have been tuned.

12.10. Electrical Resonance Type Frequency Meters. Two types of electrical resonance frequency meters being described here.

1. Ferrodynamic Type Frequency Meter-Construction. Fig. 12.13 shows the construction of an electrical resonance frequency meter. It consists of a fixed coil which is connected across the supply whose frequency is to be measured. This coil is called magnetizing coil. The magnetizing coil is mounted on a laminated iron core. The iron core has a cross-section which varies gradually over the length, being maximum near the end where the magnetizing coil is mounted and minimum at the other end. A moving coil is pivoted over this iron core. A pointer is attached to the moving coil. The terminals of the moving coil are connected to a suitable capacitor C . There is no controlling force.

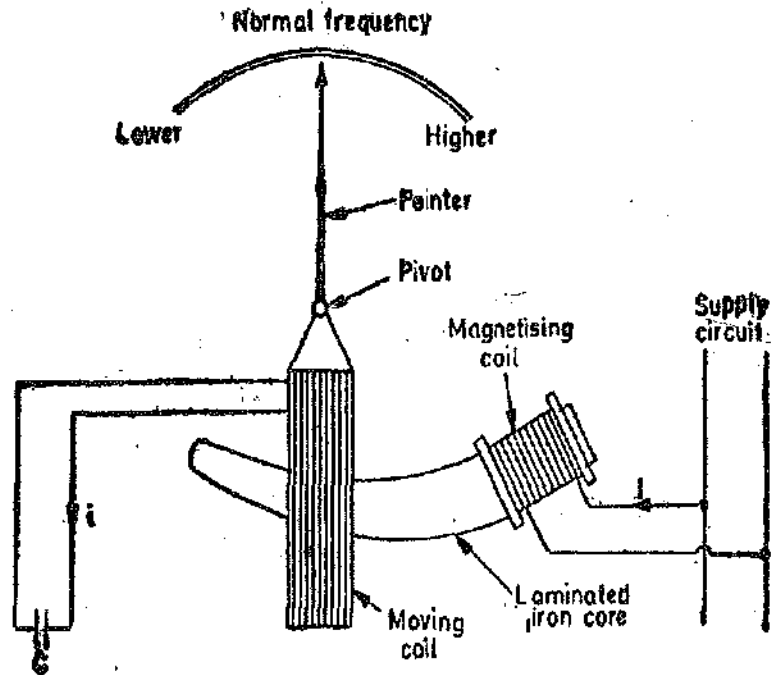

Fig. 12.13. Electrical resonance frequency meter (ferro-dynamic).

The iron core has a cross-section which varies gradually over the length, being maximum near the end where the magnetizing coil is mounted and minimum at the other end. A moving coil is pivoted over this iron core. A pointer is attached to the moving coil. The terminals of the moving coil are connected to a suitable capacitor C . There is no controlling force.

Theory and Operation. The operation of the instrument can be understood from the three phasor diagrams shown in Figs. 12.14 (a), (b), and (c). The magnetizing coil carries a current I and

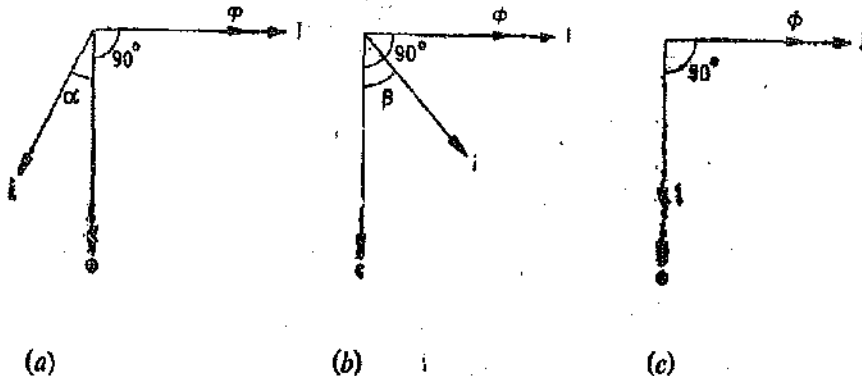

Fig. 12.14. Phasor diagrams for electrical resonance (ferrodynamic type) frequency meter.

this current produces a flux Φ . If we neglect the resistance of the coil and the iron losses in the core, flux Φ is in phase with current I . Flux Φ , being alternating in nature, induces an emf e in the moving coil. This emf lags behind the flux by 90° . The emf induced circulates a current i in the moving coil. The phase of this current i depends upon the inductance L of the moving coil and the capacitance C .

In Fig. 12'14 (a), the circuit of the moving coil is assumed to be inductive and therefore current i lags behind the emf e by an angle α . The torque acting on the moving coil is thus :

$$T_d \propto Ii \cos (90^\circ + \alpha)$$

In Fig. 11'14 (b), the moving coil circuit is assumed to be largely capacitive and therefore current i leads the emf e by an angle β and therefore the deflecting torque is :

$$T_d \propto Ii \cos (90^\circ - \beta)$$

This torque is obviously opposite to what was in the case represented in Fig. 12'14 (a).

In Fig. 12'14 (c) the inductive reactance is supposed to be equal to the capacitive reactance and, therefore, the circuit is under resonance conditions. Thus the moving coil circuit is purely resistive and so current i is in phase with emf e . This is because inductive reactance $X_L = 2\pi fL$ equals the capacitive reactance $X_C = 1/2\pi fC$, and, therefore, the net reactance of the circuit is zero.

The deflecting torque is, therefore,

$$T_d \propto Ii \cos 90^\circ = 0.$$

Hence the deflecting torque on the moving coil is zero when the inductive reactance equals the capacitive reactance.

Coming to actual operation of the instrument, for a fixed frequency, the capacitive reactance is constant but the inductive reactance of moving coil is not constant. This is because the inductance of moving coil is dependent upon the position which the moving coil occupies on the iron core. The inductance and hence inductive reactance is maximum when the moving coil occupies a position close to the magnetizing coil and minimum when it is at the other end.

The value of capacitance C is so chosen that the moving coil occupies a convenient mean position on the iron core when the frequency is at its normal value. Fig. 12'13 shows the position of the moving coil for normal frequency. This means that at this position, the value of inductance is such that for normal frequency the inductive reactance is equal to capacitive reactance. Now suppose that the frequency increases above the normal value. Under these conditions the inductive reactance becomes larger than the capacitive reactance. This is because inductive reactance $X_L \propto f$ and capacitive reactance $X_C \propto 1/f$. Thus the circuit becomes largely inductive (as $X_L > X_C$) and, therefore, there is a torque produced [See Fig. 12'14 (a)]. This torque tries to pull the moving coil to an equilibrium position, i.e., a position where the inductive reactance should equal the capacitive reactance. Since inductive reactance is larger than the capacitive reactance, this torque must move the coil to a position where its inductive reactance must come down to a value such that it equals the capacitive reactance. A decreased inductive reactance is obtained if the moving coil moves away from the magnetizing coil. The coil will come to rest when $X_L = X_C$ or when $f = 1/2\pi\sqrt{LC}$, i.e., under conditions of electrical resonance.

If the frequency decreases below the normal, value of capacitive reactance becomes more than the inductive reactance and hence there is a torque produced [See Fig. 12'14. (b)]. This torque moves the coil to a position where its inductive reactance tends to become larger and thus equal capacitive reactance. Therefore, the moving coil deflects towards the magnetizing coil.

An advantage of this instrument is that great sensitivity is achieved with its use as the inductance of moving coil changes gradually with variation of its position on the iron core.

2. **Electrodynamometer type Frequency Meter-Construction.** The schematic diagram of this meter is shown in Fig. 12'15. The fixed coil is divided into two parts 1 and 2. The two parts of the fixed coil form two separate resonant circuits. Fixed coil 1 is in series with an inductance, L_1 , and a capacitance, C_1 forming a resonant circuit of frequency, f_1 slightly below the lower end of the instrument scale. Fixed coil 2 is in series with inductance L_2 and capacitance C_2 forming a resonant circuit of frequency f_2 slightly higher than the upper end of the instrument scale. In the case of instruments for power frequency measurements, the circuits may be tuned to frequencies of 40 Hz and 60 Hz respectively, with 50 Hz in the middle of the scale.

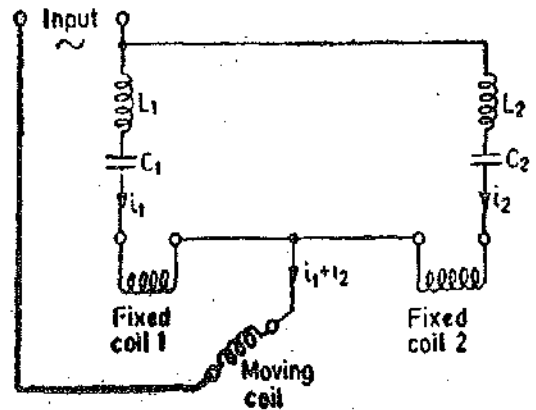

Fig. 12'15. Electro-dynamometer type frequency meter.

Operation. The two parts of fixed coil are arranged as shown in the diagram, their return circuits being through the movable coil. The torque on the movable element is proportional to the current through the moving coil. This current is the sum of the currents in the two parts of the fixed coil. For applied frequency, within the limits of the frequency range of the instrument, the circuit of fixed coil 1 operates above resonant frequency (as $X_{L1} > X_{C1}$) with current i_1 through it, lagging the applied voltage. The circuit of fixed coil 2 operates below the resonant frequency (as $X_{C2} > X_{L2}$) with current i_2 leading the applied voltage. One fixed coil circuit is inductive and the other is capacitive and therefore the torques produced by the two currents i_1 and i_2 act in opposition on the moving coil. The resultant torque is a function of frequency of the applied voltage and therefore the meter scale can be calibrated in terms of frequency. The instrument scale spreads over an angle of about 90° .

The controlling torque is provided by a small iron vane mounted on the moving system.

This meter is used only for power frequency measurements and is used in power systems for monitoring the frequency.

12'11. Weston Frequency Meter

Construction. This frequency meter consists of two coils mounted perpendicular to each other. Each coil is divided into two sections. The connections are as shown in Fig. 12'16. The branch circuit of coil A has a resistor R_A connected in series with it while coil B has a reactance coil L_B in series. Circuit of coil A is in parallel with a reactance coil L_A while that of coil B is in parallel with resistance R_B . The moving element is a soft iron needle. This needle is pivoted on a spindle which also carries a pointer and damping vanes. There is no controlling force. The series reactance coil L acts to suppress higher harmonics in the current of instrument and therefore tends to minimize the waveform errors in its indication.

Operation. The meter is connected across the supply and the two coils carry currents. These currents set up two magnetic fields which are at right angles to each other. The magnitude of the field depends upon the value of current flowing in the coil. Both these fields act upon the soft iron needle and the needle takes up a position which depends upon the relative magnitudes of the two fields and hence of the currents.

The meter is so designed that the values of various resistances and inductances are such that for normal frequency of supply the value of voltage drops across reactance L_A and resistance R_B send equal currents through coils A and B. Therefore, the needle takes up a position which is at 45° to both the coils and the pointer is at the centre of the scale as shown in Fig. 12'16.

Now if the frequency increases above its normal value, reactances of L_A and L_B increase while resistances R_A and R_B remain the same. This means that with an increase in frequency, the voltage impressed upon coil A increases as compared with that across coil B. Hence the current in coil A increases while it decreases in coil B (owing to increase in reactance of L_B). Thus the field of coil A becomes stronger than that of coil B. The tendency of the needle is to deflect towards the

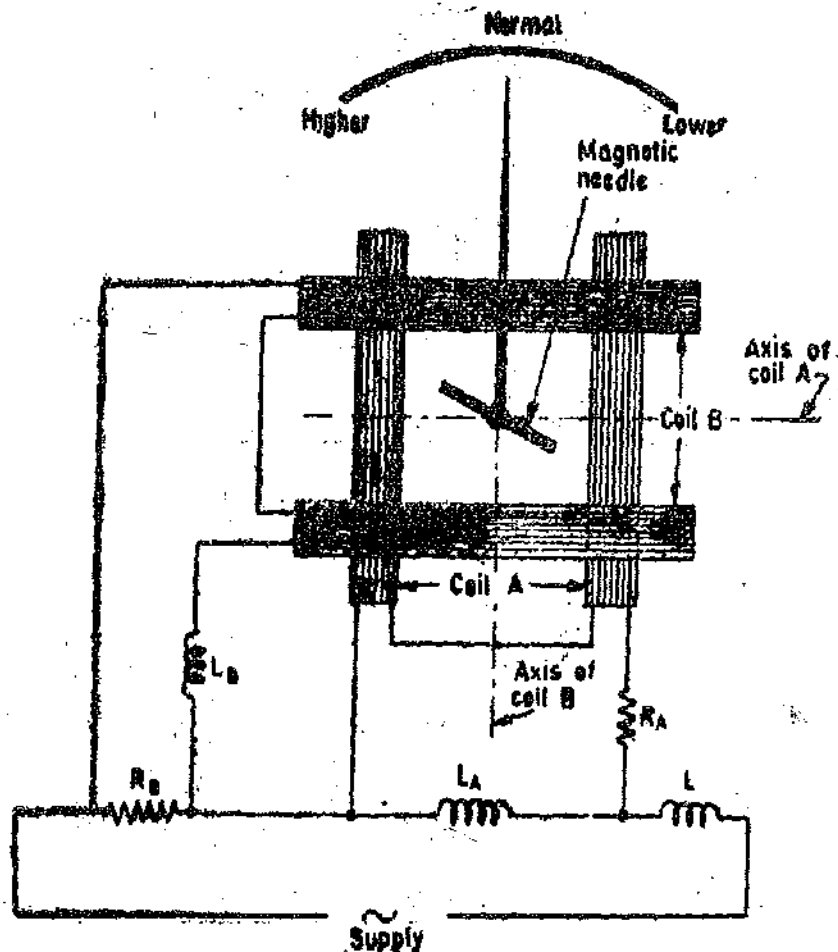

Fig. 12.16. Weston frequency meter.

stronger field and therefore, it tends to set itself in line with axis of coil A. Thus the pointer deflects to the left.

When the frequency decreases an opposite action takes place and the pointer deflects to the right.

12.12. Ratiometer Type Frequency Meter

Construction. A ratiometer type frequency meter consists of a ratiometer which gives a linear relationship between the current ratio and the deflection. The two coils of this ratiometer are fed with rectified output currents of two separate bridge rectifiers as shown in Fig 12.17. The input sides of the two bridge rectifiers are connected to alternating current supply whose frequency is to be measured. Input side of one bridge rectifier has a series capacitance C and the other has series resistance R .

Theory and Operation. Let V be the supply voltage and f be its frequency. Output current of bridge rectifier 1 is :

$$I_1 \propto I_0 \propto 2\pi fVC.$$

Output current of bridge rectifier 2

$$I_2 \propto I_R \propto \frac{V}{R}.$$

(The above relationships hold good only if the waveform is sinusoidal)

$$\therefore \text{Deflection } \theta = K \frac{I_1}{I_2} \quad (\text{see Equ. 8.51, page 217})$$

$$= K_1 \frac{2\pi f VC}{V/R} = 2\pi K_1 CRf$$

Now K_1 , C and R are constants. $\therefore \theta = K_2 f$.

Thus the instrument has a linear scale of frequency in case the ratiometer is so designed that the deflection is directly proportional to the ratio of two currents.

It is clear from above that the supply voltage V does not appear in the expression for deflection. Thus the instrument may be used for a fairly wide range of voltage below the maximum specified. However, the voltage should not be too low otherwise distortions are introduced which make the meter read wrongly.

This meter may be used upto a frequency of 5000 Hz.

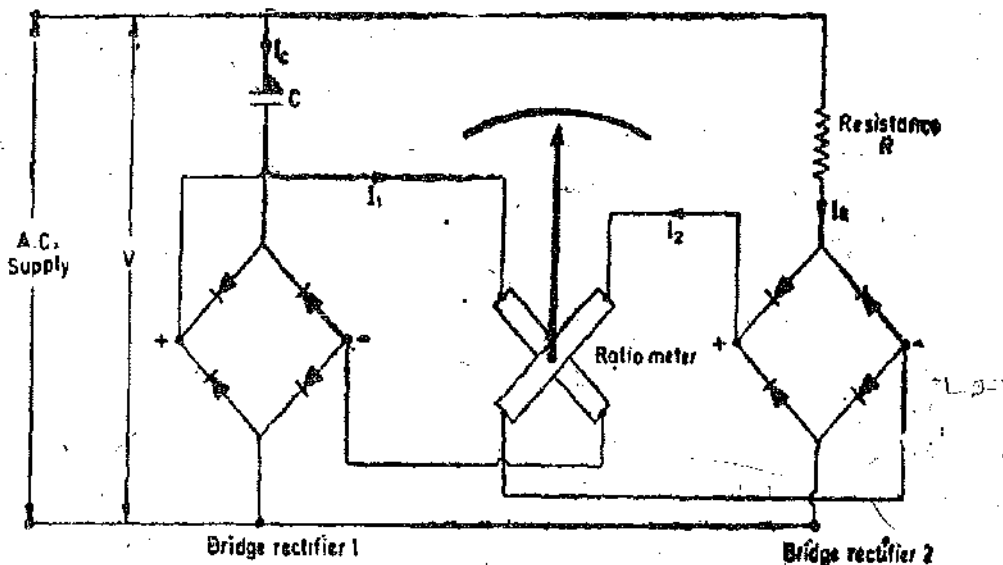

Fig. 12 17. Ratiometer type frequency meter.

12 13. Saturable Core Frequency Meter. A saturable core frequency meter is shown in Fig. 12 18. This meter has a saturable core transformer as its primary detector. The core assembly consists of three parts viz : (i) an outer core which is made of magnetic material and has a sufficiently large cross-section so that it does not saturate ; (ii) a leg A made of non-magnetic material ; (iii) a leg B which is made of magnetic material, the cross-section of leg A being the same as that of B. The leg B saturates at low values of mmfs.

The primary (input) winding is wound around both legs A and B. The secondary winding consists of two coils, one around leg A and the other around B. The two coils are connected in series. The emfs induced in these two coils oppose each other. When there is saturation, the rate of increase of induced voltage in the secondary coil over leg A will equal the rate of increase of induced voltage in secondary coil wound over magnetic leg B. Thus the rate of increase in these two coils will cancel, and the secondary output voltage will not be a function of the primary voltage but will be a function of frequency only.

Let Φ be the difference between the flux of leg A and leg B. Then the induced emf in the secondary winding is :

$$e = N \frac{d\Phi}{dt}$$

and the average secondary voltage per half cycle is :

$$E_{av} = \frac{\omega}{\pi} \int_0^{\pi/\omega} e dt = \frac{\omega}{\pi} N \int_{-\Phi_m}^{+\Phi_m} d\Phi = 4N f \Phi_m \quad \text{or frequency } f = \frac{E}{4N\Phi_m} = KE$$

where K is a constant after the magnetic leg B becomes saturated. The output of this circuit is rectified and the current in the d.c. meter is :

$$I_{av} = \frac{E_{av}}{R}$$

where R includes the resistance of the bridge rectifier, the meter and the resistance R_1 . Therefore

$$f = KR I_{av}$$

The deflection θ is directly proportional to current I_{av} as current is detected by a PMMC meter or deflection $\theta \propto I_{av} \propto f$.

Thus the deflection of meter is directly proportional to the frequency.

This type of frequency meter has the advantage that it can measure frequencies over a wide range and is especially well suited for use in tachometer systems.

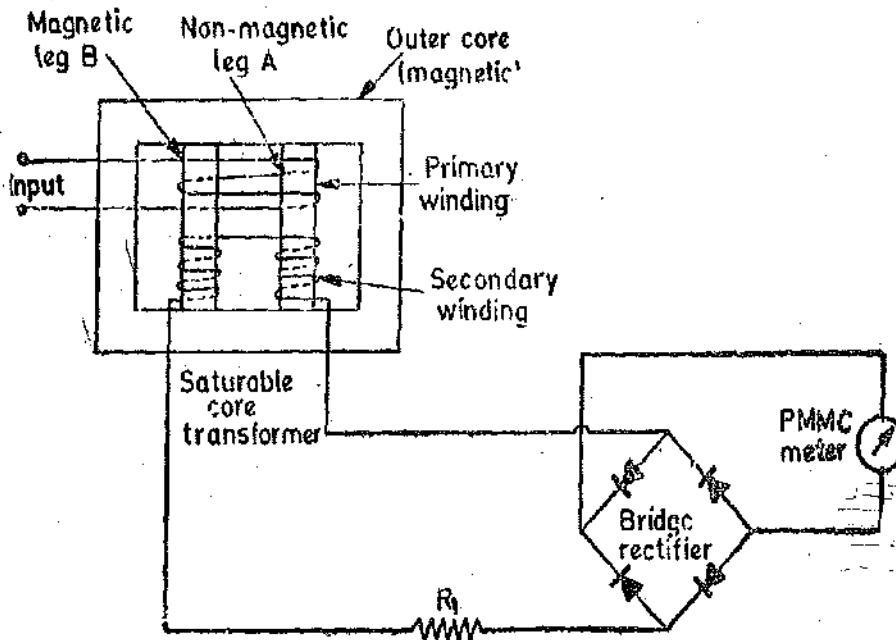

Fig. 12'18. Saturable core frequency meter.

SYNCHROSCOPES

12'14. Synchronizing. A synchroscope is used to determine the correct instant for closing the switch which connects an alternator to the power station busbars. This process of connecting at the correct instant or synchronizing is necessary when an unloaded "incoming" machine is to be connected to the busbars in order to share the load.

The correct instant of synchronizing is when the busbar and the incoming machine voltages

- (i) are equal in magnitude,
- (ii) are in phase,
- and (iii) have the same frequency.

For a 3 phase machine the phase sequence of the two should be the same. This condition is verified by a phase sequence indicator.

The voltages can be checked with the help of a voltmeter. The function of the synchroscope is to indicate the difference in phase and frequency of voltage of the busbar and the incoming machine.

Synchrosopes may either be of the electro-dynamometer type or the moving iron type. Both types are special forms of respective power factor meters.

12'15. Electro-dynamometer (Weston) type Synchroscope

Construction. Fig. 12'19 shows a simple circuit of a Weston type synchroscope. It consists of a three limbed transformer. The winding on one of the outer limbs is excited from busbars and that

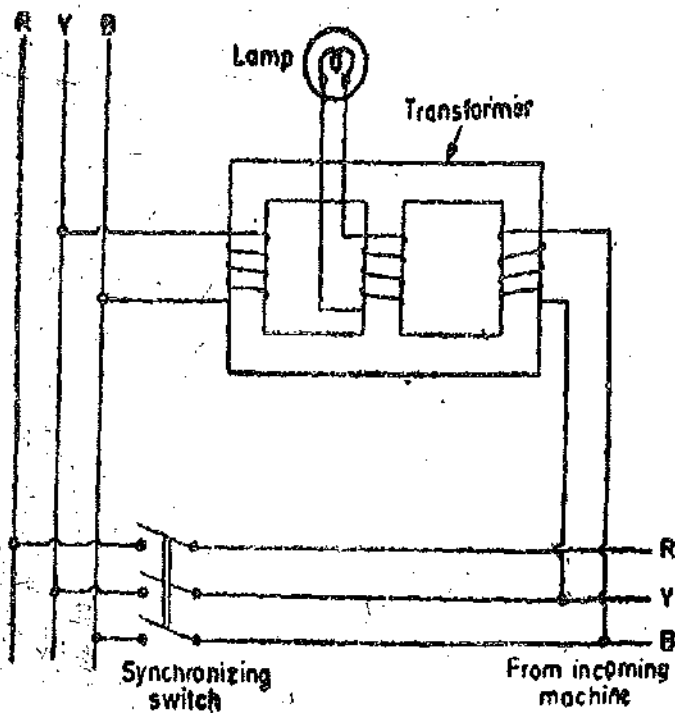

Fig. 12'19. Weston type synchroscope.

on the other outer limb by the incoming machine. The winding on the central limb is connected to a lamp.

The windings on the outer limbs produce two fluxes which are forced through the central limb. The resultant flux through the central limb is equal to the phasor sum of these fluxes. This resultant flux induces an emf in the winding of the central limb. The two outer limb windings are so arranged that when the busbar and the incoming machine voltages are in phase, the two fluxes through the central limb are additive and thus emf induced in the central limb winding is maximum. Hence under these conditions the lamp glows with maximum brightness. When the two voltages are 108° out of phase with each other the resultant flux is zero and hence no emf is induced in the central limb winding, with the result the lamp does not glow at all and is dark. If the frequency of the incoming machine is different from that of the busbars, the lamp will be alternately bright and dark or in other words the lamp flickers. The frequency of flickering is

equal to the difference in frequencies of the busbar and the incoming machine.

The correct instant of synchronizing is when the lamp is flickering at a very slow rate and is at its maximum brightness.

One of the defects of this simple circuit is that it does not indicate whether the incoming machine is too fast or too slow. This defect can be corrected by introducing an electro-dynamometer

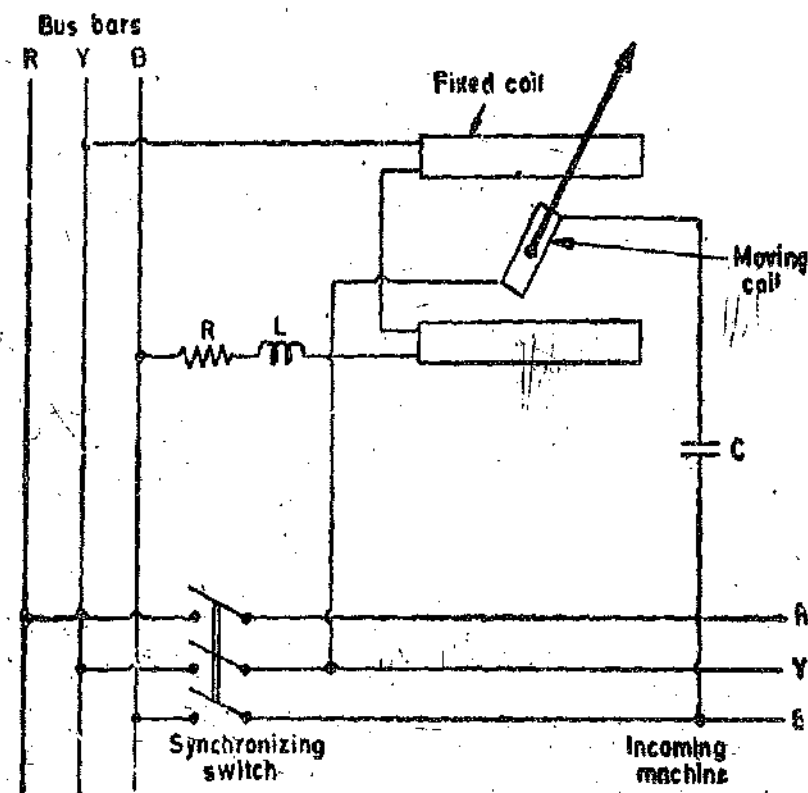

Fig. 12'20. Weston type synchroscope.

type instrument into the circuit shown in Fig. 12'19. This instrument is connected as shown in Fig. 12'20.

The electro-dynamometer instrument consists of a fixed coil divided into two parts. The fixed coil is designed to carry a small current and is connected in series with a resistance across the busbars. The moving coil is connected in series with a capacitor across the terminals of the incoming machine. The instrument is provided with control springs which act as current leads for the moving coil. The shadow of the pointer is thrown on an opal glass.

When the two voltages are in phase with each other, currents I_1 and I_2 in fixed and moving coils respectively will be in quadrature with each other [Fig. 12'21 (a)] and, therefore, there will be no torque on the instrument. The control springs are so arranged that the pointer is in vertical position under this condition. Also the lamp is at its maximum brightness and the pointer is silhouetted against the opal glass.

If the incoming machine voltage V_2 is leading on the busbar voltage V_1 and the incoming machine slightly too slow, the conditions of the circuit will slowly change from those shown in

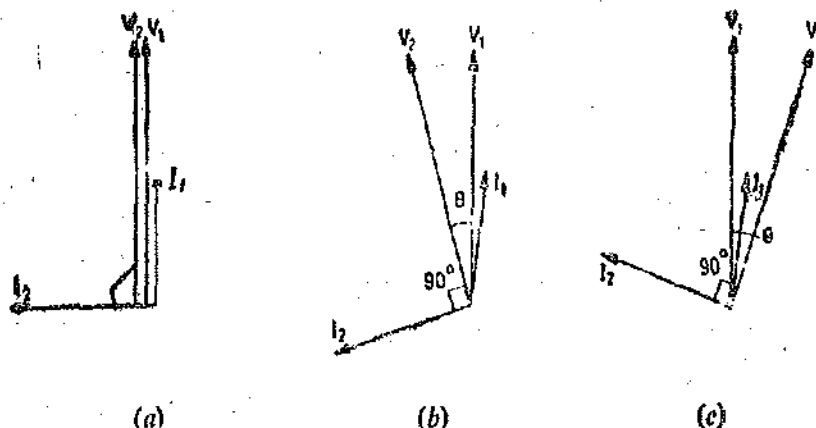

Fig. 12'21. Phasor diagrams for different conditions.

Fig. 12'21 (b) to those shown in Fig. 12'21 (c). Then the torque will change from $KI_1I_2 \cos (90 + \theta)$ to $KI_1I_2 \cos (90 - \theta)$ i.e., from a negative value through zero to a positive value. And during this period lamp will be bright and the pointer will be seen to move from left hand side of dial through the vertical position to the right hand side of dial. The dial can thus be marked with directions Fast and Slow as shown in Fig. 12'22.

During this period when the voltages V_1 and V_2 are 180° out of phase the pointer will move back. But it will not be visible as under these conditions as the lamp is dark.

The visible movement of the pointer is therefore a series of traverses on the dial in one direction. If the incoming machine is too fast the visible traverses will be in the other direction. The correct instant of synchronizing is when the pointer is visible at its central position and is moving very slowly.

It may be observed that in order to have an exact quadrature relationship between currents I_1 and I_2 when voltages V_1 and V_2 are in phase, is obtained only if a small inductance L is introduced in the fixed coil circuit.

12'16. Moving Iron Synchroscopes

Construction. Fig. 12'23 shows the construction of a moving iron synchroscope which is due to Lipman. It has a fixed coil divided into two parts. This fixed coil A is designed for a small value of current and is connected in series with a resistance across two phases of the busbar. There are two iron cylinders C_1 and C_2 mounted on the spindle. Each iron cylinder is provided with two iron vanes whose axes are 180° out with each other. The iron cylinders are excited by two pressure coils P_1 and P_2 which are connected to two phases of the incoming machine. One of the coils has a series resistance

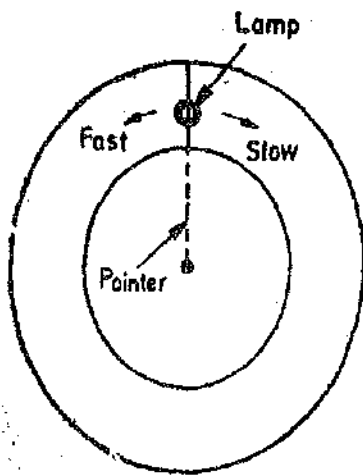

Fig. 12'22. Dial of a Weston synchroscope.

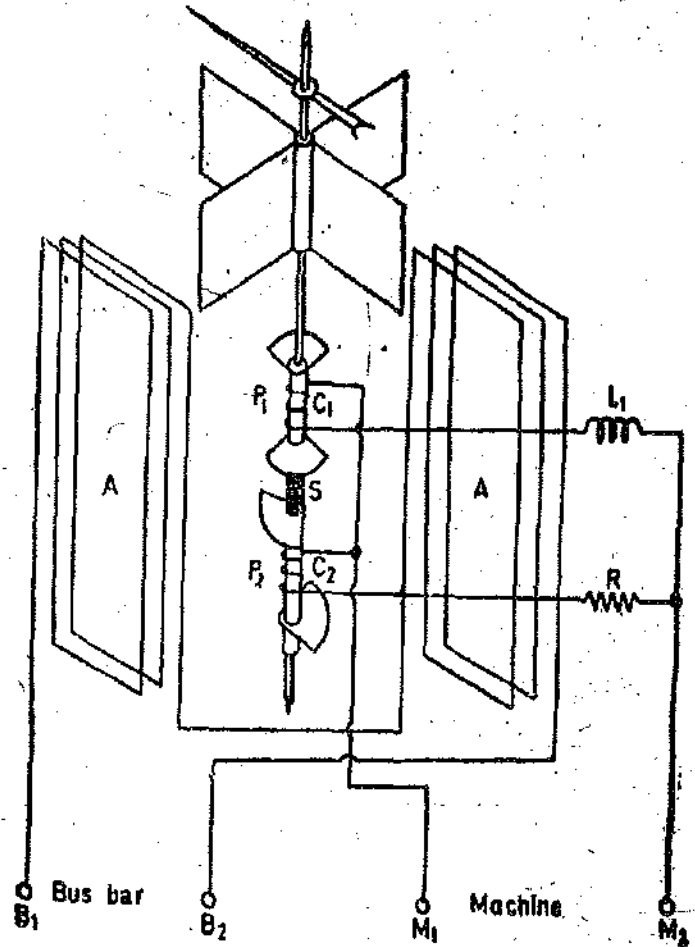

Fig. 12'23. Nalder Lipman type synchroscope.

and the other has a series inductance. This is done in order to create an artificial phase difference of 90° between the currents of two pressure coils. There are no control springs. The instrument is provided with a pointer which moves over a dial marked Fast and Slow.

Theory and Operation. When the frequency of incoming machine is the same as that of the busbars, the instrument behaves exactly like the corresponding form of the power factor meter. The deflection of the pointer from the plane of reference is equal to phase difference between the two voltages.

However if the frequencies of the two voltages are different, the pointer rotates continuously at a speed corresponding to difference in frequency of the two voltages. The direction of rotation depends whether the incoming machine is too fast or too slow.

Let V_1 and V_2 be the voltages of busbar and incoming machine respectively. Let the frequencies of the two voltages be equal.

Torques produced by coils P_1 and P_2 . $T_1 = KV_1V_2 \sin \theta \cos (\pm \alpha)$

$T_2 = KV_1V_2 \sin (90 - \theta) \cos (90 \pm \alpha) = K_1V_1V_2 \cos \theta \sin (\pm \alpha)$

where θ = deflection of the pointer from plane of reference. This plane of reference is the vertical position of the pointer.

α = phase angle between the two voltages.

The two torques are in opposite direction, therefore, under equilibrium $T_1 = T_2$

$$KV_1V_2 \sin \theta \cos (\pm \alpha) = K_1V_1V_2 \cos \theta \sin (\pm \alpha). \quad \text{or} \quad \theta = \pm \alpha.$$

Thus the pointer is stationary and its deflection from plane of reference equals the phase difference between two voltages.

If the frequency of the incoming machine differs from that of the busbars, the torques are

$$T_1 = K_1 V_1 V_2 \sin \theta \cos (\pm 2\pi f' t \pm \alpha)$$

and $T_2 = K_1 V_1 V_2 \sin (90^\circ - \theta) \cos [90^\circ - (\pm 2\pi f' t \pm \alpha)] = K_1 V_1 V_2 \cos \theta \sin (\pm 2\pi f' t \pm \alpha)$

where $f' = f_2 - f_1 = \text{difference in two frequencies.}$

Hence at equilibrium

$$\sin \theta \cos (\pm 2\pi f' t \pm \alpha) = \cos \theta \sin (\pm 2\pi f' t \pm \alpha) \quad \text{or} \quad \theta = \pm 2\pi f' t \pm \alpha.$$

Thus the moving system rotates with a frequency corresponding to difference in the two frequencies. The direction of rotation depends upon whether the frequency of incoming machine is higher (f' positive) or lower (f' negative) than the frequency at the busbars.

The instant of synchronizing is when the pointer is stationary ($f' = 0$) and when it is at its vertical position.

Moving iron synchrosopes are more common in use. They are cheap and their operation is simple and also they have a 360° scale.

12.17. Phase Sequence Indicators. These instruments are used to determine the phase sequence of three phase supplies. There are two types of phase sequence indicators.

(i) Rotating type. (ii) Static type.

(i) Rotating Type. The principle of working of these meters is similar to that of 3 phase induction motors.

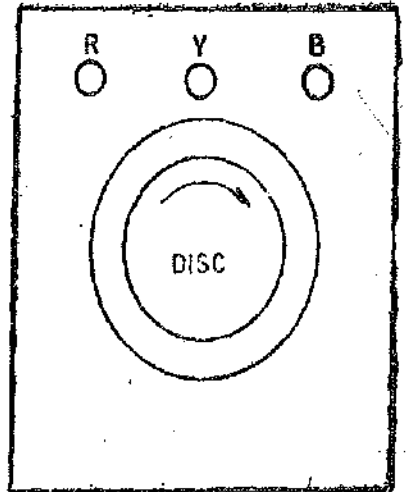

Fig. 12.24. Phase sequence indicator.

They consist of three coils mounted 120° apart in space. The three ends of the coils are brought out and connected to three terminals marked RYB as shown in Fig. 12.24. The coils are star connected and are excited by the supply whose phase sequence is to be determined. An aluminium disc is mounted on the top of the coils. The coils produce a rotating field and eddy emfs are induced in the disc. These emfs cause eddy currents to flow. A torque is produced with the interaction of the current with the field. The disc revolves because of the torque and the direction of rotation depends upon the phase sequence of the supply.

An arrow indicates the direction of the rotation of the disc. If the direction of the rotation is the same as that indicated by the arrow head, the phase sequence of the supply is the same as marked on the terminals of the instrument. However, if the disc revolves opposite to the direction indicated by the arrowhead, the sequence of the supply is opposite to that marked on the terminals.

(ii) Static Type. One arrangement consists of two lamps and an inductor as shown in Fig. 12.25 (a). When the phase sequence is RYB, lamp 1 will be dim and lamp 2 will glow brightly. If the phase sequence is RB Y, lamp 1 will glow brightly and lamp 2 will be dim.

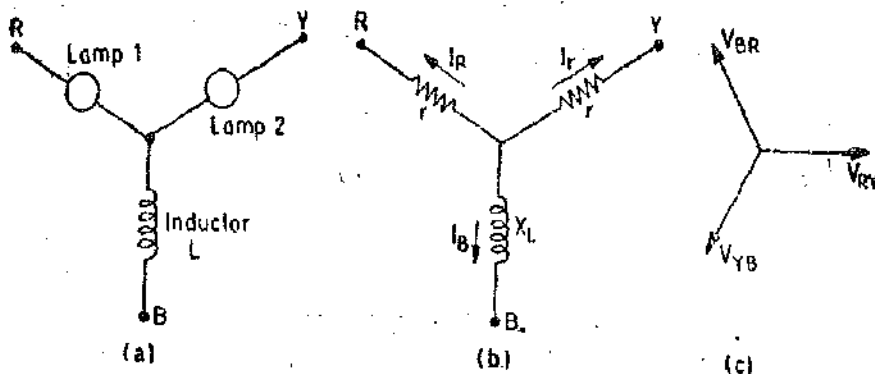

Fig. 12.25. Circuit of a static phase sequence indicator.

The principle of operation may be understood from the following analysis. Assume that the phase sequence is RYB and that phasor relations of voltages V_{RY} , V_{YB} and V_{BR} are as shown in Fig. 12.25 (c).

$$V_{RY} = V(1+j0), \quad V_{YB} = V(-0.5-j0.866), \quad V_{BR} = V(-0.5+j0.866).$$

Assume the currents to be as shown in Fig. 12.25 (b), that is : $I_R + I_Y + I_B = 0$.

From Figs. 12.25 (b) and (c), $V_{RY} + V_Y r - I_R r = 0, \quad V_{YB} + I_B jX_L - I_Y r = 0$.

Solving for I_R and I_Y , we have :

$$I_R = \frac{V_{RY}}{r} + I_Y \quad \text{and} \quad I_Y = \frac{\left(V_{YB} - \frac{V_{RY} jX_L}{r} \right)}{(R + 2jX_L)}$$

then $\frac{I_R}{I_Y} = 1 + \frac{(1 + j2X_L/r)}{(V_{YB}/V_{RY}) - jX_L/r}$. But $\frac{V_{YB}}{V_{RY}} = -0.5 - j0.866$.

If the inductor is designed so that $X_L = R$ at the line frequency,

$$\frac{I_B}{I_Y} = -0.134 + j0.232 \quad \text{or} \quad \frac{I_R}{I_Y} = 0.27$$

Thus the voltage drop across lamp 1 ($I_R r$) is only 27% of that across lamp 2 (i.e., $I_B r = 0.27 I_Y r$). Thus if the phase sequence is RYB lamp 1 glows dimly while lamp 2 glows brightly.

It can be shown that, if the inductor is replaced by a capacitor of such value that $X_C = X_L$, the ratio I_R/I_Y is 3.7, which means in this case lamp 1 glows brightly and lamp 2 glows dimly if the phase sequence is RYB.

Another, similar phase sequence indicator consists of two neon lamps and a capacitor basically as shown in Fig. 12.26 (a). Actually a resistor must be used in series with each neon lamp

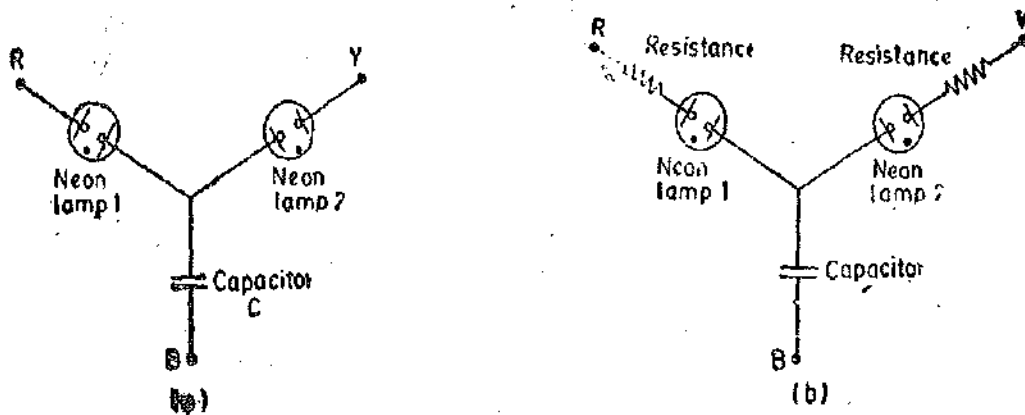

Fig. 12.26. Phase sequence indicators using neon lamp and capacitor.

to limit the current as shown in Fig. 12.26 (b). When the phase sequence is RYB, lamp 1 will glow and lamp B will be dark. This is because when neon lamps are used as indicators, the lamp which has the lower voltage will not glow at all, as the voltage across it is lower than the breakdown voltage of the lamp.

Example 12.1. In a deflectional frequency meter working on the principle of electrical resonance, there are two parallel circuits each consisting of an inductance and a capacitance in series. One circuit has $C_1 = 1 \mu F$ and is tuned to a frequency, $f_1 = 60$ Hz. The other has $C_2 = 1.5 \mu F$ and is tuned to a frequency f_2 , below 50 Hz. The resistance of each circuit is $R_1 = R_2 = 100 \Omega$. What must be the inductance of the second circuit, and to what frequency must it be tuned, in order that the current in both the circuits shall be same at a frequency of 50 Hz ?

Solution. For resonant circuit frequency, $f_1 = \frac{1}{2\pi\sqrt{L_1 C_1}}$

MEASUREMENT OF PHASE AND FREQUENCY

$$\therefore \text{Inductance of circuit 1 } L_1 = \frac{1}{4\pi^2 f_1^2 C_1} = \frac{1}{4\pi^2 \times (60)^2 \times 1 \times 10^{-6}} = 7.05 \text{ H.}$$

$$\begin{aligned} \text{Impedance of circuit 1 at 50 Hz, } Z_1 &= R_1 + j \left(\omega L_1 - \frac{1}{\omega C_1} \right) \\ &= 100 + j \left(2\pi \times 50 \times 7.05 - \frac{1}{2\pi \times 50 \times 1 \times 10^{-6}} \right) = 100 + j971 \Omega. \end{aligned}$$

$$\begin{aligned} \text{Impedance of circuit 2 at 50 Hz, } Z_2 &= R_2 + j \left(\omega L_2 - \frac{1}{\omega C_2} \right) \\ &= 100 + j \left(2\pi \times 50 \times L_2 - \frac{1}{2\pi \times 50 \times 1.5 \times 10^{-6}} \right) = 100 + j(314 L_2 - 2120). \end{aligned}$$

For equal currents in two circuits, $Z_1 = Z_2$, or $314L_2 - 2120 = 971$
or inductance of circuit 2, $L_2 = 9.82 \text{ H.}$

$$\text{Resonant frequency of circuit 2, } f_2 = \frac{1}{2\pi} \sqrt{\frac{1}{9.82 \times 1.5 \times 10^{-6}}} = 41.15 \text{ Hz.}$$

Measurement of Resistance

13.1. **Classification of Resistances.** The classification of resistances, from the point of view of measurement, is as follows :

(i) **Low Resistance.** All resistances of the order of 1 ohm and under may be classified as low resistances.

(ii) **Medium Resistances.** This class includes resistances from 1 ohm upwards to about 100,000 ohm.

(iii) **High Resistances.** Resistances of the order of 100,000 ohm and upwards are classified as high resistances.

The classification outlined above is not rigid, but forms a basis for techniques, followed for measurement, which may be different for different classes.

MEASUREMENT OF MEDIUM RESISTANCES

13.2. **Methods of Measurement of Medium Resistances.** The different methods used for measurement of medium resistances are :

- | | |
|---------------------------------|---------------------------|
| (i) Ammeter-Voltmeter method. | (ii) Substitution method. |
| (iii) Wheatstone bridge method. | (iv) Ohmmeter method. |

13.3. **Ammeter Voltmeter Method.** This method is very popular since the instruments required for this test are usually available in the laboratory. The two types of connections employed for ammeter-voltmeter method are shown in Figs. 13.1 (a) and (b). In both the cases, if readings of ammeter and voltmeter are taken, then the measured value of resistance is given by

$$R_m = \frac{\text{voltmeter reading}}{\text{ammeter reading}} = \frac{V}{I} \quad \dots(13.1)$$

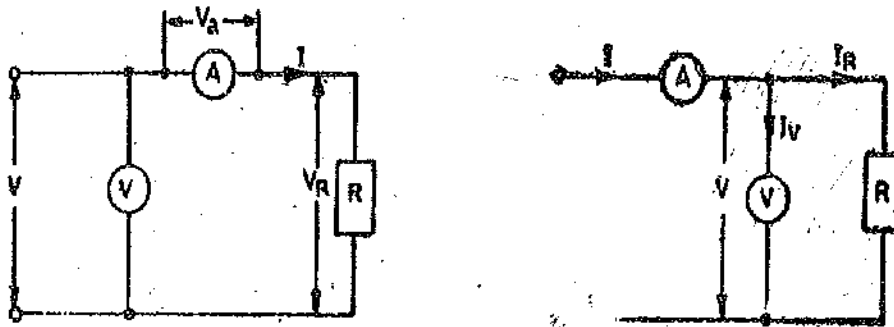

Fig. 13.1. Measurement of resistance by ammeter-voltmeter method.

The measured value of resistance R_m , would be equal to the true value, R , if the ammeter resistance is zero and the voltmeter resistance is infinite, so that the conditions in the circuit are not disturbed. However, in practice this is not possible and hence both the methods give inaccurate results.

Circuit of Fig. 13.1 (a). In this circuit the ammeter measures the true value of the current through the resistance but the voltmeter does not measure the true voltage across the resistance. The voltmeter indicates the sum of the voltages across the ammeter and the resistance.

Let R_a be the resistance of the ammeter. \therefore Voltage across the ammeter, $V_a = IR_a$.

Now, measured value of resistance

$$R_{m1} = \frac{V}{I} = \frac{V_R + V_a}{I} = \frac{IR + IR_a}{I} = R + R_a \quad \dots(13'2)$$

\therefore True value of resistance, $R = R_{m1} - R_a \quad \dots(13'3)$

$$= R_{m1} \left(1 - \frac{R_a}{R_{m1}} \right) \quad \dots(13'4)$$

Thus the measured value of resistance is higher than the true value. It is also clear from above that the true value is equal to the measured only if the ammeter resistance, R_a , is zero.

$$\text{Relative error, } \epsilon_r = \frac{R_{m1} - R}{R} = \frac{R_a}{R} \quad \dots(13'5)$$

It is clear from Eqn. 13'5 that the error in measurements would be small if the value of resistance under measurement is large as compared to the internal resistance of the ammeter. Therefore the circuit of Fig. 13'1 (a) should be used when measuring high resistance values.

Circuit of Fig. 13'1 (b). In this circuit the voltmeter measures the true value of voltage but the ammeter measures the sum of currents through the resistance and the voltmeter.

Let R_v be the resistance of the voltmeter

$$\therefore \text{Current through the voltmeter, } I_v = \frac{V}{R_v}$$

$$\text{Measured value of resistance, } R_{m2} = \frac{V}{I} = \frac{V}{I_R + I_v} = \frac{V}{V/R + V/R_v} = \frac{R}{1 + R/R_v}$$

$$\text{True value of resistance, } R = \frac{R_{m2} R_v}{R_v - R_{m2}} = R_{m2} \left(\frac{1}{1 - R_{m2}/R_v} \right) \quad \dots(13'6)$$

From Eqn. 13'6 it is clear that the true value of resistance is equal to the measured value only if the resistance of voltmeter, R_v , is infinite. However, if the resistance of voltmeter is very large as compared to the resistance under measurement :

or $R_v \gg R_{m2}$, so that R_{m2}/R_v is very small,

$$\text{Thus we have: } R = R_{m2} \left(1 + \frac{R_{m2}}{R_v} \right) \quad \dots(13'7)$$

Thus the measured value of resistance is smaller than the true value.

$$\text{Relative error, } \epsilon_r = \frac{R_{m2} - R}{R} = -\frac{R_{m2}^2}{R_v R} \quad \dots(13'8)$$

$$\text{The value of } R_{m2} \text{ is approximately equal to } R. \therefore \epsilon_r = -\frac{R}{R_v} \quad \dots(13'9)$$

It is clear from Eqn. 13'8 that the error in measurement would be small if the value of resistance under measurement is very small as compared to the resistance of the voltmeter. Hence the circuit of Fig. 13'1 (b) should be used when measuring low resistance values.

The Ammeter-Voltmeter method, in the two forms explained above, is a simple method but is, essentially a comparatively rough method, the accuracy being limited by those of ammeters and voltmeters used, even if corrections are made for the voltage drop across the ammeter for connections of Fig. 13'1 (a) and for the shunting effect for connections of Fig. 13'1 (b). If the two instruments are of 0.5% accuracy and are read near full scale, the instrumental error in the result may be any thing from 0 to 1%. If read near half scale, the percentage error may be twice as great and for lower readings may mount considerably higher. With less accurate instruments the possible error, of course,

is increased. It is difficult to secure much better than 1% accuracy in a resistance value under usual conditions, and the error sometimes may be considerably higher. However, the method is useful in some laboratory work in which high accuracy is not required.

The suitability of a particular method for resistance measurement depends upon the relative values of resistance under measurement and the resistance of the meters.

The division point between the two methods is at the resistance for which the relative errors given by the two methods are equal.

The relative errors for the two cases are equal when

$$\frac{R_a}{R} = \frac{R}{R_v} \quad (\text{See eqns. 13'5 and 13'9})$$

or when true value of resistance $R = \sqrt{R_a R_v}$... (13'10)

For resistances greater than the value given by Eqn. 13'10 the method of Fig. 13'1 (a) is used while for lower resistances method of 13'1 (b) is used.

Example 13'1. In the measurement of a resistance, R , by the voltmeter-ammeter method, connections as in Fig. 13'1 (a) and 13'1 (b) are used. The resistance of ammeter is 0.01Ω and that of voltmeter, 2000Ω . In case of (b) the current measured is 2 A and the voltage 180 V . Find the percentage error in calculating resistance R as a quotient of the readings and the true value of R . Also find the reading of the voltmeter in case of (a) if the current indicated by the ammeter is 2 A .

Solution : Case (b) See Fig. 13'1 (b)

$$\text{Measured value of resistance } R_m = \frac{V}{I} = \frac{180}{2} = 90 \Omega.$$

$$\text{Current through the voltmeter } I_v = \frac{V}{R_v} = \frac{180}{2000} = 0.09 \text{ A.}$$

$$\text{Current through the resistance } I_R = I - I_v = (2.0 - 0.09) \text{ A.}$$

$$\text{True value of resistance } R = \frac{V}{I_R} = \frac{180}{(2.0 - 0.09)} = 94.3 \Omega.$$

$$\text{Percentage error} = \frac{R_m - R}{R} \times 100 = \frac{90 - 94.3}{94.3} = -4.56\%.$$

Case (a) See Fig. 13'1 (a)

$$\text{Reading of voltmeter } V = V_a + V_R = I(R_a + R) = 2(0.01 + 94.3) = 188.62 \text{ V.}$$

Example 13'2. A resistance of approximate value of 80Ω is to be measured by voltmeter-ammeter method using a 1 A ammeter having a resistance of 2Ω and a 50 V voltmeter having a resistance of 5000Ω .

(a) Suggest which one of the two methods should be used ?

(b) Supposing in the suggested method the following measurements are made :

$$I = 0.42 \text{ A} \quad \text{and} \quad V = 35.5 \text{ V.}$$

What is the resulting error if the accuracy of the instruments is $\pm 0.5\%$ at full scale and the errors are standard deviations.

Solution. (a) Value of resistance for which the errors are equal for the two types of connections

$$R = \sqrt{R_a R_v} = \sqrt{2 \times 5000} = 100 \Omega.$$

Since the resistance to be measured has a value less than 100Ω , the method of Fig. 13'1 (b) should be used as it results in smaller error.

$$\text{Measured value of resistance } R_m = \frac{V}{I} = \frac{35.5}{0.42} = 84.5 \Omega.$$

$$\text{True value of resistance } R = R_{m2} \left(\frac{1}{1 - R_{m2}/R_v} \right) = 84.5 \left(\frac{1}{1 - 84.5/5000} \right) = 86 \Omega$$

$$(b) \text{ Error in ammeter reading} = \frac{0.5}{100} \times 1 = 0.005 \text{ A.}$$

$$\therefore \text{ Percentage error at } 0.42 \text{ A reading} = \frac{0.05}{0.42} \times 100 = 1.19\%$$

$$\text{Error in voltmeter reading} = 0.5 \times \frac{50}{100} = 0.25 \text{ V.}$$

$$\therefore \text{ Percentage error at } 35.5 \text{ V reading} = \frac{0.25}{35.5} \times 100 = 0.71\%$$

Since the errors correspond to standard deviations, error due to ammeter and voltmeter

$$= \sqrt{(1.19)^2 + (0.71)^2} = \pm 1.38\%$$

$$\text{Absolute error due to ammeter and voltmeter} = \pm \frac{1.38}{100} \times 86 = \pm 1.2 \Omega.$$

\therefore The resistance is specified as $86 \pm 1.2 \Omega$.

Example 13.3. A resistance R is measured using the connections of Fig. 13.1 (a). The current measured is 10 A on range 10 A and the voltage measured is 125 V on 150 V range. The scales of the ammeter and voltmeter are uniform, the total scale divisions of ammeter are 100 and that of voltmeter are 150. The scales of these instruments are such that 1/10 of a scale division can be distinguished. The constructional error of the ammeter is $\pm 0.3\%$ and that of voltmeter $\pm 0.4\%$. The resistance of the ammeter is 0.25Ω . Calculate the value of R and the limits of possible error in the results.

Solution :

$$\text{Reading error of ammeter} = \pm \frac{1}{10 \times 100} \times 100 = \pm 0.1\%$$

$$\text{Reading error of voltmeter} = \pm \frac{1}{10 \times 125} \times 100 = \pm 0.08\%$$

$$\text{Total error of ammeter } \delta I = \pm 0.3 \pm 0.1 = \pm 0.4\%$$

$$\text{Total error of voltmeter } \delta V = \pm 0.4 \pm 0.08 = \pm 0.48\%$$

Now, resistance $R = V/I$ and therefore total systematic error in measurements

$$= \pm \delta V \pm \delta A = \pm 0.48 \pm 0.4 = \pm 0.88\%$$

$$\text{Measured value of resistance } R_{m2} = \frac{125}{10} = 12.5 \Omega.$$

$$\text{True value of resistance } R = R_{m1} \left(1 - \frac{R_a}{R_{m1}} \right) \quad (\text{See Eqn. 13.5})$$

$$= 12.5 \left(1 - \frac{0.25}{12.5} \right) = 12.25 \Omega.$$

Therefore the value of R is specified as : $12.25 \Omega \pm 0.88\% = 12.25 \pm 0.12 \Omega$.

13'4. Substitution method. The connection diagram for this method is shown in Fig. 13'2. R is the unknown resistance while S is a standard variable resistance. 'A' is an ammeter and 'r' is a regulating resistance. There is a switch for putting R and S into the circuit alternately.

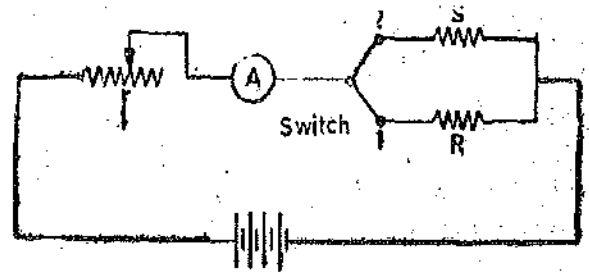

Fig. 13'2. Substitution method.

The switch is put at position '1' and resistance R is connected in the circuit. The regulating resistance r is adjusted till the ammeter pointer is at a chosen scale mark. Now, the switch is thrown to position '2' putting the standard variable resistance S in the circuit. The value of S is varied till the same deflection—as was obtained with R in the circuit—is obtained. The settings of the dials of S are read. Since the substitution of one resistance for another has left the current unaltered, and provided that the emf of battery and the position of r are unaltered, the two resistances must be equal. Thus the value of unknown resistance R is equal to the dial settings of resistance S .

This is a more accurate method than the ammeter—voltmeter method, as it is not subject to the errors encountered in the latter method. However, the accuracy of this method is destroyed if there is any change in the battery emf during the time the readings on the two settings are taken. Thus in order to avoid errors on this account, a battery of ample capacity should be used so that its emf remains constant.

The accuracy of the measurement naturally depends upon the constancy of the battery emf and of the resistance of the circuit excluding R and S , upon the sensitivity of the instrument, and upon the accuracy with which standard resistance S is known.

This method is not widely used for simple resistance measurements and is used in a modified form for the measurement of high resistances. The substitution principle, however, is very important and finds many applications in bridge methods and in high frequency a.c. measurements.

Example 13'4. In a measurement of resistance by substitution method a standard $0.5 \text{ M}\Omega$ resistor was used. The galvanometer has a resistance of $10 \text{ k}\Omega$ and gives deflections as follows :

- (i) With standard resistor, 41 divisions.
- (ii) With unknown resistance, 51 divisions.

Find the unknown resistance.

Solution. The deflection of the galvanometer is directly proportional to the current passing through the circuit and hence is inversely proportional to the total resistance of the circuit. Let S , R and G be respectively the resistances of standard resistor, unknown resistor and the galvanometer. Also let θ_1 be the deflection with standard resistor in circuit and θ_2 with unknown resistor in circuit.

$$\frac{\theta_1}{\theta_2} = \frac{R+G}{S+G}$$

Hence unknown resistance $R = (S+G) \frac{\theta_1}{\theta_2} - G = (0.5 \times 10^6 + 10 \times 10^3) \times \frac{41}{51} - 10 \times 10^3$
 $= 0.4 \times 10^6 \Omega = 0.4 \text{ M}\Omega.$

13'5. Wheatstone Bridge. A very important device used in the measurement of medium resistances is the Wheatstone bridge. Fig. 13'3 shows the basic circuit of a Wheatstone bridge. It has four resistive arms, together with a source of emf (a battery) and a null detector, usually a galvanometer G or other sensitive current meter. The current through the galvanometer depends on the potential difference between points c and d . The bridge is said to be balanced when there is no current through the galvanometer or when the potential difference across the galvanometer is zero. This occurs when the voltage from point 'c' to point 'a' equals the voltage from point 'd' to point 'a'; or, by referring to the other battery terminal, when the voltage from point 'c' to point 'b' equals the voltage from point 'd' to point 'b'.

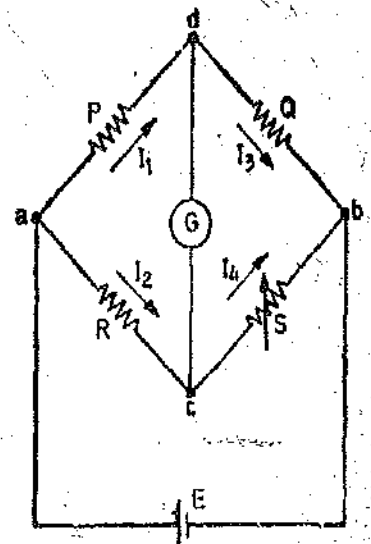

Fig. 13'3. Wheatstone bridge.

For bridge balance, we can write :

$$I_1 P = I_2 R$$

...(13'11)

For the galvanometer current to be zero, the following conditions also exist :

$$I_1 = I_3 = \frac{E}{P+Q} \quad \dots(13'12)$$

and

$$I_2 = I_4 = \frac{E}{R+S} \quad \dots(13'13)$$

where

$E = \text{emf of the battery.}$

Combining Eqns. 13'11, 13'12 and 13'13 and simplifying, we obtain :

$$\frac{P}{P+Q} = \frac{R}{R+S} \quad \dots(13'14)$$

from which

$$QR = PS \quad \dots(13'15)$$

Eqn. 13'15 is the well known expression for the balance of wheatstone bridge. If three of the resistances are known, the fourth may be determined from Eqn. 13'15 and we obtain :

$$R = S \frac{P}{Q} \quad \dots(13'16)$$

where S is called the 'standard arm' of the bridge and P and Q are called the 'ratio arms'.

In the industrial and laboratory form of the bridge, the resistors which make up P , Q and S are mounted together in a box, the appropriate values being selected by dial switches. Battery and galvanometer switches are also included together with a galvanometer and a dry battery in the portable sets. P and Q normally consist of four resistors each, the values being 10, 100, 1000 and 10,000 Ω respectively S consists of a 4 dial or 5 dial decade arrangement of resistors. Fig. 13'4 shows the commercial form of Wheatstone bridge.

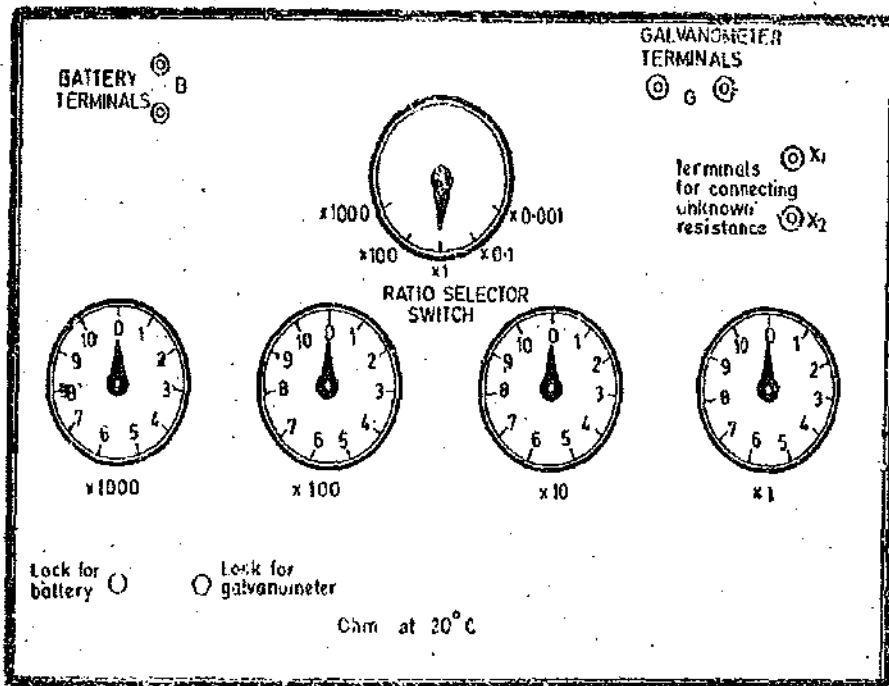

Fig. 13'4. Commercial form of Wheatstone bridge.

13'6. Sensitivity of Wheatstone Bridge. It is frequently desirable to know the galvanometer response to be expected in a bridge which is slightly unbalanced, so that a current flows in the galvanometer branch of the bridge network. This may be used for :

- (i) selecting a galvanometer with which a given unbalance may be observed in a specified bridge arrangement,

(ii) determining the minimum unbalance which can be observed with a given galvanometer in the specified bridge arrangement,

and (iii) determining the deflection to be expected for a given unbalance.

The sensitivity to unbalance can be computed by solving the bridge circuit for a small unbalance. The solution is approached by converting the Wheatstone bridge of Fig. 13'3 to its "Thevenin Equivalent" circuit. Assume that the bridge is balanced when the branch resistances are P, Q, R, S so that $P/Q = R/S$. Suppose the resistance R is changed to $R + \Delta R$ creating an unbalance. This will cause an emf e to appear across the galvanometer branch. With galvanometer branch open, the voltage drop between points a and d is :

$$E_{ad} = I_1 P = \frac{EP}{P+Q}$$

$$\text{Similarly } E_{ac} = I_2(R + \Delta R) = \frac{E(R + \Delta R)}{R + \Delta R + S}$$

Therefore voltage difference between points c and d is :

$$e = E_{ac} - E_{ad} = E \left[\frac{R + \Delta R}{R + \Delta R + S} - \frac{P}{P + Q} \right] \quad \dots(13'17)$$

$$\text{and since } \frac{P}{P+Q} = \frac{R}{R+S}$$

$$\begin{aligned} \therefore e &= E \left[\frac{R + \Delta R}{R + \Delta R + S} - \frac{R}{R + S} \right] = \frac{ER}{R + S} \left[\frac{1 + \Delta R/R}{1 + \Delta R/(R + S)} - 1 \right] \\ &\approx \frac{ER}{R + S} \left[\left(1 + \frac{\Delta R/R}{R} \right) \left(1 - \frac{\Delta R}{R + S} \right) - 1 \right] \end{aligned}$$

as ΔR is very small compared with $R + S$

$$\text{Neglecting the terms containing } \Delta R^2, \text{ we get } e = \frac{ES\Delta R}{(R + S)^2} \quad \dots(13'18)$$

Let S_V be the voltage sensitivity of galvanometer.

$$\text{Therefore, deflection of galvanometer is : } \theta = S_V e = S_V \frac{ES\Delta R}{(R + S)^2} \quad \dots(13'19)$$

The bridge sensitivity S_B is defined as the deflection of the galvanometer per unit fractional change in unknown resistance.

$$\text{Bridge sensitivity } S_B = \frac{\theta}{\Delta R/R} \quad \dots(13'20)$$

$$= \frac{S_V E S R}{(R + S)^2} \quad \dots(13'21)$$

From Eqn. 13'21 it is clear that the sensitivity of the bridge is dependent upon bridge voltage, bridge parameters and the voltage sensitivity of the galvanometer.

Rearranging the terms in the expression for sensitivity

$$S_B = \frac{S_V E}{(R + S)^2 / SR} = \frac{S_V E}{\frac{R}{S} + 2 + \frac{S}{R}} \quad \dots(13'22)$$

From Eqn. 13'22, it is apparent that maximum sensitivity occurs where $R/S = 1$. As the ratio becomes either larger or smaller, the sensitivity decreases. Since the accuracy of measurement is dependent upon sensitivity a limit can be seen to the usefulness for a given bridge, battery and galvanometer combination.

As explained above the sensitivity is maximum when the ratio is unity. The sensitivity with ratio $P/Q = R/S = 1000$ would be about $1/1000$ of that for unity ratio. The sensitivity with $P/Q = R/S = 1/1000$ would similarly be about $1/1000$ of that for unity ratio.

Thus the sensitivity decreases considerably if the ratio $P/Q = R/S$ is greater or smaller than unity. This reduction in sensitivity is accompanied by a reduction in accuracy with which a bridge can be balanced

13.7. Galvanometer Current. The current through the galvanometer can be found out by finding the Thevenin equivalent circuit. The Thevenin or open circuit voltage appearing between terminals d and c with galvanometer circuit open circuited is

$$E_0 = E_{ac} - E_{ad} = I_2 R - I_1 P = \frac{ER}{R+S} - \frac{EP}{P+Q} = E \left[\frac{R}{R+S} - \frac{P}{P+Q} \right] \quad \dots(13.23)$$

The resistance of the Thevenin Equivalent circuit is found by looking back into terminals c and d (Fig. 13.3) and replacing the battery by its internal resistance. In most cases, however, the extremely low resistance of the battery can be neglected and this simplifies the solution as we can assume that terminals a and b are shorted. The Thevenin equivalent resistance can be calculated by referring to Fig. 13.5.

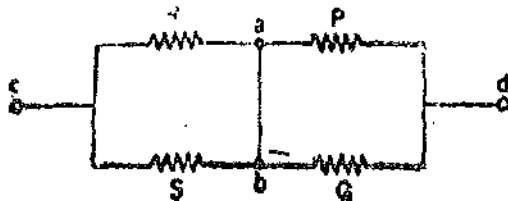

Fig. 13.5. Finding resistance of bridge looking into terminals c and d .

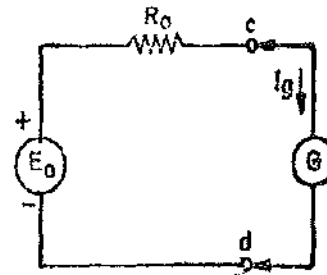

Fig. 13.6. Thevenin equivalent circuit of wheatstone bridge.

Thevenin equivalent resistance of bridge $R_0 = \frac{RS}{R+S} + \frac{PQ}{P+Q}$... (13.24)

The Thevenin equivalent of the bridge circuit therefore reduces to a Thevenin generator with an emf E_0 and an internal resistance R_0 . This circuit is shown in Fig. 13.6.

\therefore The current in the galvanometer circuit $I_g = \frac{E_0}{R_0 + G}$... (13.25)

where

$G =$ resistance of the galvanometer circuit.

The deflection of the galvanometer for a small change in resistance in the unknown arm is

$$\theta = \frac{S_v E S \Delta R}{(R+S)^2}$$

But $S_v = \frac{S_i}{R_0 + G}$ where $S_i =$ current sensitivity of the galvanometer.

$$\therefore \theta = \frac{S_i E S \Delta R}{(R_0 + G)(R+S)^2} \quad \dots(13.26)$$

Also bridge sensitivity, $S_B = \frac{\theta}{\Delta R/R} = \frac{S_i E S R}{(R_0 + G)(R+S)^2}$... (13.27)

13.8. Precision Measurement of Medium Resistances with Wheatstone Bridge. It is sometimes necessary to measure resistances to a precision of 1 part in 10,000 or even greater by comparing them with standard resistances. In such cases more than ordinary precautions are necessary in order to secure the required accuracy. The following factors should be taken into consideration.

(i) **Resistance of connecting leads.** A lead of 22 SWG wire having a length of 25 cm has a

resistance of about 0.012Ω and this represents more than 1 part in 100 for a 10Ω resistance or more than one part in 10,000 for a 100Ω resistance.

2. **Thermo-electric Effects.** Thermoelectric emfs are often present in the measuring circuit and they must be taken into account since they affect the galvanometer deflection in the same way as an emf occurring because of unbalance. The effect of thermoelectric emfs and other parasite emfs on the measurement may be eliminated by reversing the battery connections to the bridge through a quick acting switch and adjusting the balance until no change in galvanometer deflection can be observed on reversal. The results are obtained by averaging the two readings. This way the effect of thermo-electric emfs is eliminated with the added advantage of doubling the sensitivity of the bridge.

3. **Temperature Effects.** The errors caused by change of resistance due to change of temperature produces serious errors in measurements especially in the case of resistances made up of materials having a large value of resistance temperature coefficient. For example in the case of copper, which has a resistance temperature coefficient of $0.004 \Omega/\Omega\text{-}^\circ\text{C}$, a change in temperature of 1°C will cause an error of 0.4% or 1 part in 250.

4. **Contact Resistance.** Serious errors may be caused by contact resistances of switches and binding posts. A dial may have a contact resistance of about 0.003Ω and thus a 4 dial resistance box has a contact resistance of about 0.01Ω . This value is quite high especially when low resistance measurements are being done. Another aspect of the contact resistance is that error caused by it are difficult to account for since its magnitude is uncertain.

In precision resistance measurements, the most accurate comparisons are made on an equal ratio bridge with a fixed standard resistance nominally equal to resistance under test. Then with equal leads, equal currents and equal heating of the ratio arms, the possible errors are minimized. The problem is then reduced to that of determining the exact ratio of the unknown resistance, R , to the standard resistance S or the difference between them. The different methods used for this purpose are :

(i) **Change in Ratio Arms.** Small known changes are made in the ratio arms and the exact balance is obtained.

(ii) **Using a High Resistance Shunt.** In this case the bridge is balanced by means of an adjustable high resistance put in parallel with one of the bridge arms. A decade resistance box is used for this purpose. Suppose the test resistance, R , is slightly lower in value than the standard resistance, S and let the balance be obtained with a resistance xS put in parallel with S . The resistance of this arm is then $xS^2/(S+xS)$, i.e. $S/(1+1/x)$.

$$\therefore \text{Value of unknown resistance } R = \frac{P}{Q} \cdot \frac{S}{1+1/x}$$

Since x is very large and therefore $1/x$ is very small and hence we can write,

$$R = \frac{P}{Q} \cdot S \left(1 - \frac{1}{x} \right) \quad \dots(13.28)$$

$$\text{For an equal arm bridge, } P=Q \text{ and therefore, } R=S \left(1 - \frac{1}{x} \right) \quad \dots(13.29)$$

The fractional difference, $1/x$ between S and R can be known. Since this method determines the fractional difference and x has a large value, the high resistance put in parallel with S need not be particularly accurate.

(iii) **Carey Foster Slide Wire Bridge.** A slide wire bridge is used for the purpose of determining the difference between the standard and the unknown resistances. The details are explained below.

13'9. **Carey-Foster Slide-wire Bridge.** The connections of this bridge are shown in Fig. 13'7, a slide-wire of length L being included between R and S as shown. This bridge is specially suited for the comparison of two nearly equal resistances.

Resistances P and Q are first adjusted so that the ratio P/Q is approximately equal to the ratio R/S . Exact balance is obtained by adjustment of the sliding contact on the slide-wire. Let l_1 be the distance of the sliding contact from the left-hand end of the slide wire. The resistances R and S are then interchanged and balance again obtained. Let the distance now be l_2 .

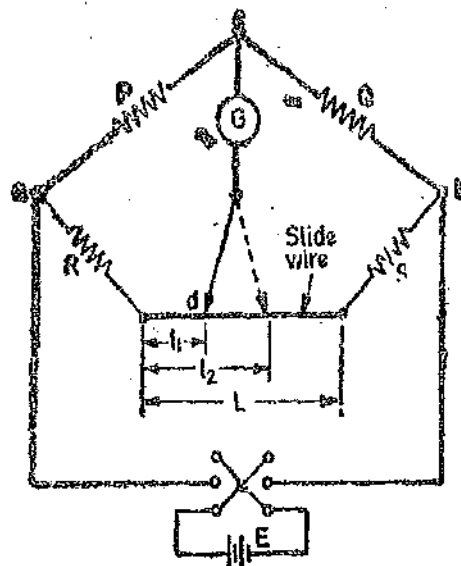

Fig. 13'7. Carey-Foster Slide-wire bridge.

Then, for the first balance,
$$\frac{P}{Q} = \frac{R + l_1 r}{S + (L - l_1) r}$$

where r is the resistance per unit length of the slide-wire.

For the second balance,
$$\frac{P}{Q} = \frac{S + l_2 r}{R + (L - l_2) r}$$

Now,
$$\frac{P}{Q} + 1 = \frac{R + l_1 r + S + (L - l_1) r}{S + (L - l_1) r} = \frac{R + S + Lr}{S + (L - l_1) r}$$

also
$$\frac{P}{Q} + 1 = \frac{S + l_2 r + R + (L - l_2) r}{R + (L - l_2) r} = \frac{S + R + Lr}{R + (L - l_2) r}$$

$$\therefore S + (L - l_1) r = R + (L - l_2) r, \quad \text{Hence } S - R = (l_1 - l_2) r \quad \dots(13'30)$$

Thus the difference between S and R is obtained from the resistance per unit length of the slide-wire together with the difference $(l_1 - l_2)$ between the two slide-wire lengths at balance.

The slide-wire is calibrated—i.e. r is obtained by shunting either S or R by a known resistance and again determining the difference in length $(l_1' - l_2')$.

Suppose that S is known and that S' is its value when shunted by a known resistance ; then

$$S - R = (l_1 - l_2) r \quad \text{and} \quad S' - R = (l_1' - l_2') r$$

$$\therefore \frac{S - R}{l_1 - l_2} = \frac{S' - R}{l_1' - l_2'}, \quad \text{from which} \quad R = \frac{S(l_1' - l_2') - S'(l_1 - l_2)}{(l_1' - l_2') - (l_1 - l_2)} \quad \dots(13'31)$$

Eqn. 13'31 shows that this method gives a direct comparison between S and R in terms of lengths only, the resistances of P and Q , contact resistances, and the resistances of connecting leads being eliminated.

As it is important that the two resistors R and S shall not be handled or disturbed during the measurement, a special switch is used to effect the interchanging of these two resistors during the test.

13'10. **Kelvin Varley Slide.** A Kelvin-Varley slide is used for voltage division. This method is very precise and finds extensive applications. A Kelvin Varley slide is shown in Fig. 13'8. It consists of several decades of resistors which are interconnected. The voltage division is carried out successively. Each voltage division decade is made up of eleven equal resistors with successive division decades having a total resistance equal to twice the value of a unit resistor in the previous decade. For example, in the Kelvin Varley Slide shown in Fig. 13'8, there are four decade dividers. This decade is constructed using 11 resistance coils having a resistance of 10 kΩ each. The second

decade divider has 11 resistors of $2\text{ k}\Omega$ each*. Similarly the 3rd decade has 11 resistors of $400\ \Omega$ each and the fourth and final decade has 10 resistors of $80\ \Omega$ each.

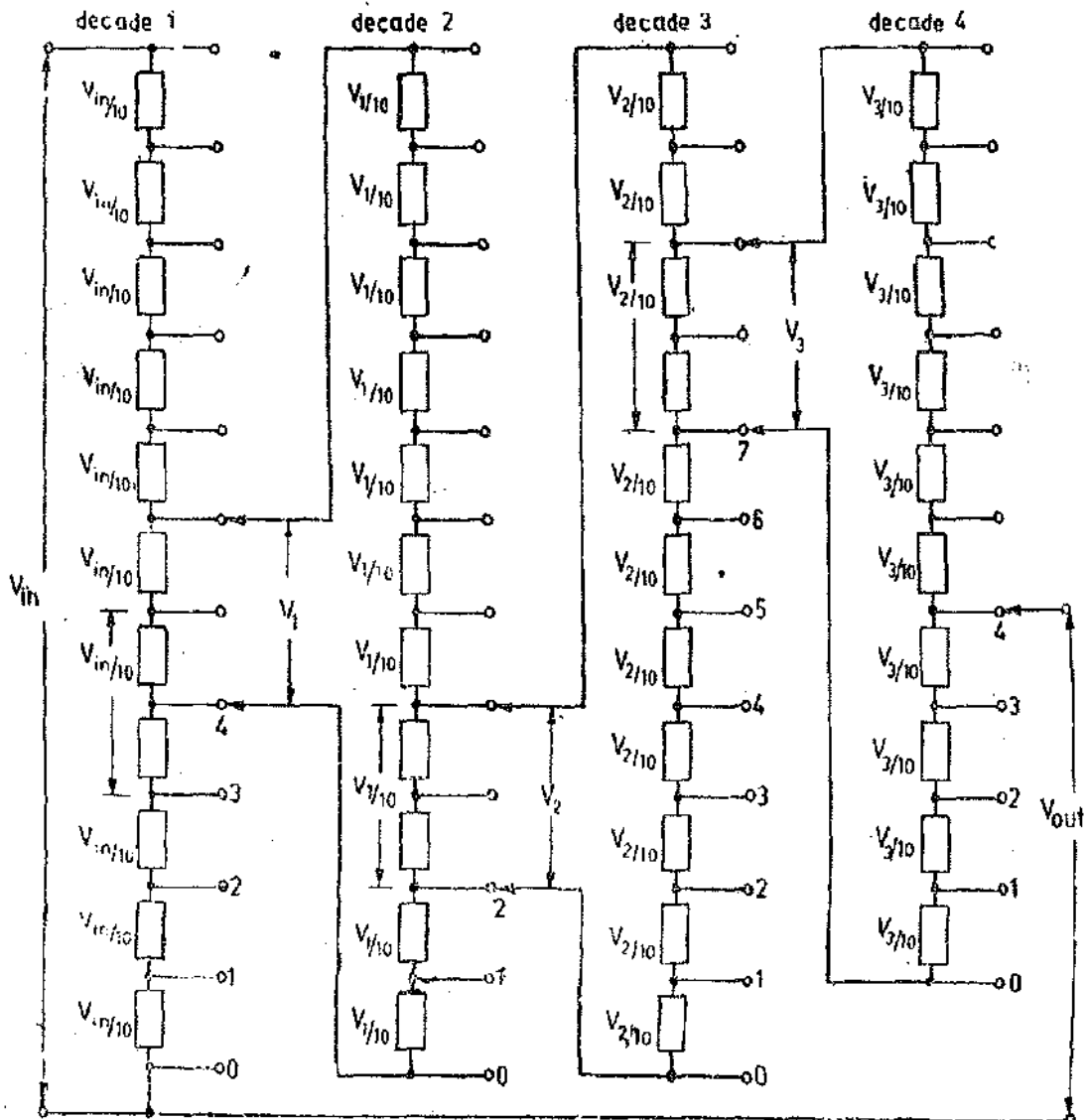

Fig. 13*8. Kelvin-Varley divider set to 0.4274.

The use of 11 resistors to obtain a decade voltage division enables the Kelvin Varley Slide to have a constant input resistance irrespective of which switch positions are connected on the various decades. (However this is strictly true if output terminals are open circuited). For example decade 3 has a constant input resistance of :

$$9 \times 400 + \frac{2 \times 400 \times 10 \times 80}{800 + 800} = 4000\ \Omega = 4\text{ k}\Omega$$

Decade 2 has an input resistance of

$$9 \times 2000 + \frac{2 \times 2000 \times 4000}{4000 + 4000} = 20,000\ \Omega = 20\text{ k}\Omega$$

The input terminal impedance is $100\text{ k}\Omega$ irrespective of the switch position if it is assumed that the output current is negligible.

The advantage of using the Kelvin-Varley Slide is the reduction of errors which arise on account of switch contact resistance due to current sharing within the device. The disadvantages

*Resistance of each unit in first decade is $10\text{ k}\Omega$. The second decade has a total resistance of $2 \times 10 = 20\text{ k}\Omega$. Therefore each unit in the second decade has a resistance of $20/10 = 2\text{ k}\Omega$. In other words we can say that if the first decade consists of 11 coils of resistance r ohm each, the next decade has 11 coils of $r/5$ ohm each and the third decade has 11 coils of $2r/5$ ohm each.

of the Kelvin Varley Slide are its calibration and the errors on account of temperature. The errors on account of temperature are due to the fact that the resistors carry different currents and the changes in the value of resistance is different on account of different self-heating conditions. The temperature effects can be reduced to negligible proportions by using resistors made of materials having a low resistance temperature co-efficient. The error may be reduced to as low a value as ± 0.1 ppm. The principle of Kelvin Varley Slides is used with advantage in potentiometers and universal shunts.

Fig. 13'9 shows the use of Kelvin Varley slide in a Wheatstone bridge. The device is used to replace the simple slide wire with the advantage that it gives greater accuracy.

For the case shown in Fig. 13 9

$$\frac{R}{S} = \frac{7554}{5346}$$

13'11. Limitations of Wheatstone Bridge. The use of Wheatstone bridge is limited to the measurement of resistances ranging from a few ohm to several megohm. The upper limit is set by the reduction in sensitivity to unbalance caused by high resistance values. The upper limit can be extended to a certain extent by increasing the emf applied to the bridge but in this case care has to be taken to avoid overheating of any arm of the bridge. Inaccuracy may also be introduced on account of leakage over insulation of the bridge arms when measuring very high resistances. For measurement of very high resistances, a megohm bridge (described in Art 13'25 page 448) is preferable.

The lower limit for measurement is set by the resistance of the connecting leads and by contact resistance at the binding posts. The error caused by leads may be corrected fairly well, but contact resistance presents a source of uncertainty that is difficult to overcome. The lower limit for accurate measurement is in the neighbourhood of 1 to 5 ohm. For low resistance measurements, therefore, a Kelvin bridge (described in Art. 13'16 page 440) is generally preferred.

Example 13'5. A resistance of approximately 3000 Ω is needed to balance a bridge. It is obtained on a 5 dial resistance box having steps of 1000, 100, 10, 1 and 0.1 Ω . The measurement is to be guaranteed to 0.1 percent. For this accuracy, how many of these dials would it be worth adjusting.

Solution. Limiting value of 3000 Ω resistor

$$= 3000 \pm 3000 \times \frac{0.1}{100} = 3000 \pm 3 \Omega = 2997 \text{ to } 3003 \Omega.$$

Thus it would be worth adjusting the 1000, 100, 10 and 1 Ω dials.

Example 13'6. Each of the ratio arms of a laboratory type Wheatstone bridge has guaranteed accuracy of $\pm 0.05\%$, while the standard arm has a guaranteed accuracy of $\pm 0.1\%$. The ratio arms are both set at 1000 Ω and the bridge is balanced with standard arm adjusted to 3,154 Ω . Determine the upper and the lower limits of the unknown resistance, based upon the guaranteed accuracies of the known bridge arms.

Solution. Value of unknown resistance $R = \frac{P}{Q} \cdot S = \frac{1000}{1000} \times 3154 = 3154 \Omega.$

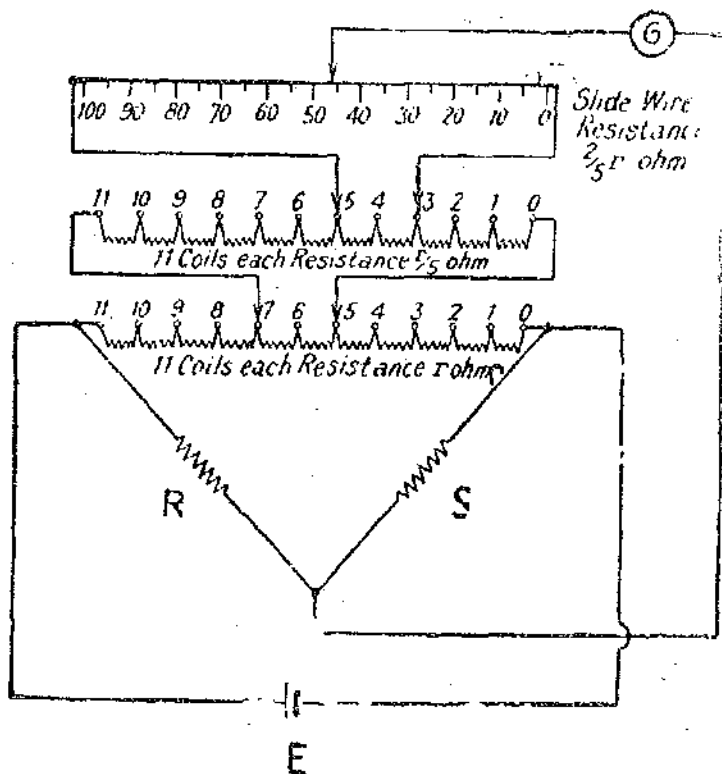

Fig. 13'9. Kelvin-Varley slide.

∴ Percentage error in determination of R

$$\frac{\delta R}{R} = \pm \frac{\delta P}{P} \pm \frac{\delta Q}{Q} \pm \frac{\delta S}{S} = \pm 0.05 \pm 0.05 \pm 0.1 = \pm 0.2\%$$

∴ Limiting values of $R = 3154 \pm 0.2\% = 3091$ to 3217Ω .

Example 13.7. In the Wheatstone bridge of Fig. 13.3, the values of resistances of various arms are $P = 1000 \Omega$, $Q = 100 \Omega$, $R = 2,005 \Omega$ and $S = 200 \Omega$. The battery has an emf of 5 V and negligible internal resistance. The galvanometer has a current sensitivity of $10 \text{ mm}/\mu\text{A}$ and an internal resistance of 100Ω . Calculate the deflection of galvanometer and the sensitivity of the bridge in terms of deflection per unit change in resistance.

Solution. Resistance of unknown resistor required for balance

$$R = \frac{P}{Q} \cdot S = \frac{1000}{100} \times 200 = 2000 \Omega.$$

In the actual bridge the unknown resistor has a value of $2,005 \Omega$ or the deviation from the balance conditions is

$$\Delta R = 2,005 - 2000 = 5 \Omega.$$

$$\begin{aligned} \text{Thevenin source generator emf } E_0 &= E \left[\frac{R}{R+S} - \frac{P}{P+Q} \right] \\ &= S \left[\frac{2005}{2005+200} - \frac{1000}{1000+100} \right] = 1.0308 \times 10^{-3} \text{ V.} \end{aligned}$$

Internal resistance of bridge looking into terminals c and d

$$R_0 = \frac{RS}{R+S} + \frac{PQ}{P+Q} = \frac{2005 \times 200}{2005+200} + \frac{1000 \times 100}{1000+100} = 272.4 \Omega.$$

$$\text{Hence the current through the galvanometer } I_g = \frac{E_0}{R_0+G} = \frac{1.0308 \times 10^{-3}}{272.4+100} \text{ A} = 2.77 \mu\text{A}.$$

Deflection of the galvanometer $\theta = S_i I_g = 10 \times 2.77 = 27.7 \text{ mm}$.

$$\text{Sensitivity of bridge } S_B = \frac{\theta}{\Delta R} = \frac{27.7}{5} = 5.54 \text{ mm}/\Omega.$$

Example 13.8. A Wheatstone bridge has ratio arms of 1000Ω and 100Ω and is being used to measure an unknown resistance of 25Ω . Two galvanometers are available. Galvanometer 'A' has a resistance of 50Ω and a sensitivity of $200 \text{ mm}/\mu\text{A}$ and galvanometer 'B' has values of 600Ω and $500 \text{ mm}/\mu\text{A}$. Which of the two galvanometers is more sensitive to a small unbalance on the above bridge, and what is the ratio of sensitivities? The galvanometer is connected from the junction of the ratio arms to the opposite corners. Comment upon the results.

Solution. The arrangement of this bridge is shown in Fig 13.3. Value of standard resistance under balance conditions.

$$S = R \cdot \frac{Q}{P} = 25 \times \frac{1000}{100} = 250 \Omega.$$

Internal resistance of bridge looking into terminals c and d

$$R_0 = \frac{RS}{R+S} + \frac{PQ}{P+Q} = \frac{25 \times 250}{25+250} + \frac{100 \times 1000}{100+1000} = 113.6 \Omega.$$

From Eqn. 13'26 the deflection for a small change in resistance

$$\theta = \frac{S_i ES \Delta R}{(R_0 + G)(R + S)^2}$$

∴ Ratio of deflections for two galvanometers

$$\begin{aligned} \frac{\theta_A}{\theta_B} &= \frac{(S_i)_A ES \Delta R}{(R_0 + G_A)(R + S)^2} \bigg/ \frac{(S_i)_B ES \Delta R}{(R_0 + G_B)(R + S)^2} = \frac{(S_i)_A}{(S_i)_B} \cdot \frac{R_0 + G_B}{R_0 + G_A} \\ &= \frac{200}{500} \times \frac{(113.6 + 600)}{(113.6 + 50)} = 1.75. \end{aligned}$$

Thus galvanometer *A* has a sensitivity of 1.75 times that of galvanometer *B* as far as this bridge is concerned, even though on its own galvanometer *A* is less sensitive than galvanometer *B*.

Example 13'9. A highly sensitive galvanometer can detect a current as low as 0.1 nA. This galvanometer is used in a Wheatstone bridge as a detector. Each arm of the bridge has a resistance of 1 kΩ. The input voltage applied to the bridge is 20 V. Calculate the smallest change in resistance which can be detected. The resistance of the galvanometer can be neglected as compared with the internal resistance of bridge.

Solution. Now $P = Q = R = S = 1 \text{ k}\Omega = 1000 \text{ }\Omega$.

∴ The internal resistance of bridge

$$R_0 = \frac{RS}{R+S} + \frac{PQ}{P+Q} = \frac{1000}{1000+1000} + \frac{1000}{1000+1000} = 1000 \text{ }\Omega.$$

Let the change in resistance be ΔR .

∴ Output voltage of bridge due to unbalance

$$E_0 = E \frac{S \Delta R}{(R+S)^2} = 20 \times \frac{1000 \times \Delta R}{(1000+1000)^2} = 5 \times 10^{-3} \Delta R$$

$$\text{Current through the galvanometer} = \frac{E_0}{R_0} = \frac{5 \times 10^{-3} \Delta R}{1000} = 0.1 \times 10^{-9}$$

∴ The smallest change in resistance which can be detected $\Delta R = 20 \times 10^{-6} \text{ }\Omega = 20 \text{ }\mu\Omega$.

Example 13'10. A regular Wheatstone bridge is used to measure high resistances (in the megohm range). The bridge has ratio arms of 10,000 Ω and 10 Ω.

The adjustable arm has a maximum value of 10,000 Ω. A battery of 10 V emf and negligible resistance is connected from the junction of ratio arms to the opposite corner ?

(a) What is the maximum resistance that can be measured by this arrangement?

(b) If the galvanometer has a sensitivity of 200 mm/μA and a resistance of 50 Ω, how much unbalance is needed to give a galvanometer deflection of 1 mm for the maximum resistance of part (a) ?

(c) If the galvanometer of part (b) is replaced by a galvanometer of sensitivity of 1000 mm/μA and a resistance of 1000 Ω, calculate the change in resistance to cause a deflection of 1 mm.

Solution. The arrangement of the bridge is shown in Fig. 13'3.

Now we have, unknown resistance $R = P/Q \times S$

$$\begin{aligned} \text{The maximum value of } R \text{ is } R &= (\text{maximum value of } P/Q) \times (\text{maximum value of } S) \\ &= \frac{10,000}{10} \times 10,000 = 100 \text{ M}\Omega. \end{aligned}$$

(b) Internal resistance of bridge

$$R_0 = \frac{RS}{R+S} + \frac{PQ}{P+Q} = \frac{10 \times 10^6 \times 10 \times 10^3}{10 \times 10^6 + 10 \times 10^3} + \frac{10 \times 10^3 \times 10}{10 \times 10^3 + 10} \approx 10,010 \Omega.$$

From Eqn. 13.26, change in resistance needed for 1 mm deflection.

$$\Delta R = \frac{0(R_0 + G)(R+S)^2}{S_i E S} = \frac{1 \times (10,010 + 50)(10 \times 10^6 + 10 \times 10^3)^2}{200 \times 10^6 \times 10 \times 10^3} \approx 0.5 \text{ M}\Omega.$$

(c) The change in resistance to cause 1 mm deflection with galvanometer having a resistance, $G = 1000 \Omega$ and current sensitivity of $S_i = 1000 \text{ mm}/\mu\text{A}$ is

$$\Delta R = \frac{1 \times (10,010 + 1000)(10 \times 10^6 + 10 \times 10^3)^2}{1000 \times 10^6 \times 10 \times 10^3} \Omega \approx 0.1 \text{ M}\Omega.$$

Example 13.11. A Wheatstone bridge is used for measuring the value of change of resistance of a strain gauge which forms one of the arms of the bridge. All the arms of the bridge including the strain gauge have a resistance of 100Ω each. The maximum allowable power dissipation from the strain gauge is 250 mW . Determine the value of maximum permissible current through the strain gauge and maximum allowable value of bridge supply voltage. Suppose a source of 20 V is available, find the value of series resistance to be connected between the source and the bridge to limit the input voltage of the bridge to permissible level.

Solution. The resistance of strain gauge $R = 100 \Omega$. Suppose I is the current through each arm under balanced conditions.

$$\therefore I^2 R = P, \text{ where } P = \text{power dissipation.}$$

$$\text{Hence, maximum permissible current} = \sqrt{P/R} = \sqrt{\frac{250 \times 10^{-3}}{100}} = 0.05 \text{ A} = 50 \text{ mA}$$

The maximum allowable voltage which can be applied to the bridge

$$= 2 \times 50 \times 10^{-3} \times 100 = 10 \text{ V}$$

\therefore Voltage across the series resistor $= 20 - 10 = 10 \text{ V}$.

$$\text{Current through the series resistor} = 2 \times 50 \times 10^{-3} \times 100 \times 10^{-3} \text{ A}$$

$$\therefore \text{Resistance of series resistor } R_s = \frac{10}{100 \times 10^{-3}} = 100 \Omega.$$

Example 13.12. In a Carey-Foster's bridge a resistance of 1.0125Ω is compared with a standard resistance of 1.0000Ω , the slide wire has a resistance of 0.0250Ω in 100 divisions. The ratio arms nominally each 10Ω , are actually 10.05Ω and 9.95Ω respectively.

How far (in scale divisions) are the balance positions from those which would obtain if ratio arms were true to their nominal value? The slide wire is 100 cm long.

Solution.

Balance with ratio arms equal to nominal values. Let l_1 be the distance of balance point on slide wire from the unknown resistance end in cm of slide wire. Let r be the resistance per cm length of slide wire.

$$\therefore r = \frac{0.0250}{100} = 0.00025 \Omega/\text{cm as length of wire is } 100 \text{ cm.}$$

In this case $P = Q = 10 \Omega$, $S = 1.000 \Omega$ and $R = 1.0125 \Omega$.

Under balance conditions,

$$\frac{P}{Q} = \frac{R + l_1 r}{S + (100 - l_1)r} \quad \text{or} \quad \frac{10}{10} = \frac{1.0125 + 0.00025 l_1}{1.0000 + 0.025 - 0.00025 l_1} \quad \text{or } l_1 = 25 \text{ cm.}$$

Thus the balance is obtained at 25 and 75 scale divisions.

Balance arms equal to true values :

Now in this case $P=9.05 \Omega$ and $Q=10.05 \Omega$.

Under balance conditions

$$\frac{9.95}{10.05} = \frac{1.0125 + 0.00025 l_1}{1.0000 + 0.025 - 0.00025 l_1} \quad \text{or} \quad \frac{1 - 0.005}{1 + 0.005} = \frac{1.0125 + 0.00025 l_1}{1.0250 - 0.00025 l_1} \quad \text{or} \quad l_1 \approx 5 \text{ cm.}$$

Thus the balance is obtained at 5 and 95 cm.

MEASUREMENT OF LOW RESISTANCE

13.12. Introduction. The methods used for measurement of medium resistances are unsuitable for measurement of low resistances *i.e.* resistances having a value under 1Ω . The reason is that the resistance of leads and contacts, though small, are appreciable in comparison in the case of low resistances. For example a contact resistance of 0.002Ω causes a negligible error when a resistance of 100Ω is being measured but the same contact resistance would cause an error of 10% if a low resistance of the value of 0.02Ω is measured. Hence special type of construction and techniques have to be used for the measurement of low resistances in order to avoid serious errors occurring on account of the factors mentioned above.

13.13. Construction of Low Resistances. Low resistances are constructed with four terminals as shown in Fig 13.10. One pair of terminals CC' (called the current terminals) is used to lead current to and from the resistor. The voltage drop is measured between the other two terminals PP' , called the potential terminals.

The voltage V , indicated in Fig. 13.9, is thus I_R times the resistance R between terminals PP' and does not include any contact resistance drop that may be present at the current terminals CC' .

Resistors of low values are thus measured in terms of resistance, between potential terminals, which becomes perfectly and precisely definite in value and is independent of the contact resistance drop at the current terminals.

Contact resistance drop at the potential terminals need not be a source of error, as current crossing at these terminals is usually extremely small or even zero for null methods. Also this contact resistance now becomes a part of the potential circuit and is, therefore, a negligible part of the total resistance of the potential circuit since potential circuits have a high value of resistance.

13.14. Methods for Measurement of Low Resistance. The methods for measurement of low resistance are :

1. Ammeter voltmeter method.
2. Kelvin's double bridge method.
3. Potentiometer method (This is explained in chapter 14).
4. Ducter (This has been explained in Art. 8.26 Page 219).

13.15. Ammeter Voltmeter Method. The ammeter voltmeter method explained in Art. 12.3 is used. For low resistances circuit of Fig. 13.1(b) and re-illustrated in Fig. 13.9 is employed.

$$\text{True value of resistance } R = R_m \left(\frac{1}{1 - R_m/R_v} \right)$$

where R_m = measured value of resistance = V/I and R_v = resistance of voltmeter.

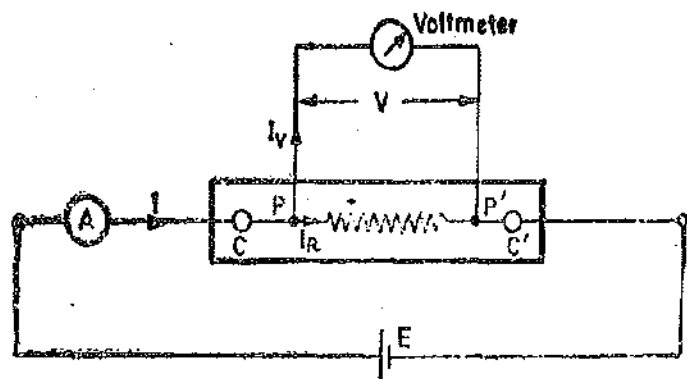

Fig. 13.10. Ammeter voltmeter method for measuring 4 terminal resistances.

13.16. Kelvin Double Bridge

Principle of Kelvin Bridge. The Kelvin bridge is a modification of the Wheatstone bridge and provides greatly increased accuracy in measurement of low value resistances. An understanding of the Kelvin bridge arrangement may be obtained by a study of the difficulties that arise in a Wheatstone bridge on account of the resistance of the leads and the contact resistances while measuring low valued resistors.

Consider the bridge circuit shown in Fig. 13.11 where r represents the resistance of the lead that connects the unknown resistance R to standard resistance S . Two galvanometer connections indicated by dotted lines, are possible. The connection may be either to point 'm' or to point 'n'. When the galvanometer is connected to point m , the resistance, r , of the connecting leads is added to the standard resistance, S , resulting in too low an indication for unknown resistance R . When the connection is made to point n , the resistance, r , is added to the unknown resistance resulting in too high a value for R .

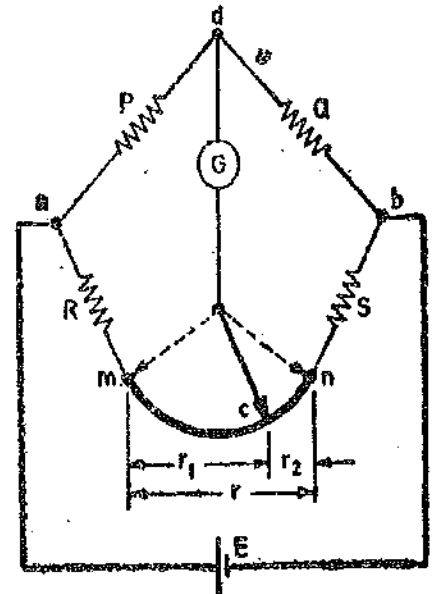

Fig. 13.11. Illustrating principle of Kelvin bridge.

Suppose that instead of using point m , which gives a low result, or n , which makes the result high, we make the galvanometer connection to any intermediate point 'c' as shown by full line in Fig. 13.11. If at point 'c' the resistance r is divided into two parts, r_1 and r_2 , such that

$$\frac{r_1}{r_2} = \frac{P}{Q} \quad \dots(13.33)$$

Then the presence of r_1 the resistance of connecting leads, causes no error in the result. We have,

$$R + r_1 = \frac{P}{Q} \cdot (S + r_2) \quad \dots(13.34)$$

but $\frac{r_1}{r_2} = \frac{P}{Q}$ (See Eqn. 13.33)

or $\frac{r_1}{r_1 + r_2} = \frac{P}{P + Q}$ or $r_1 = \frac{P}{P + Q} \cdot r$ as $r_1 + r_2 = r$ and $r_2 = \frac{Q}{P + Q} \cdot r$.

\therefore We can write Eqn. 13.34 as $\left(R + \frac{P}{P + Q} r \right) = \frac{P}{Q} \left(S + \frac{Q}{P + Q} r \right)$ or $R = \frac{P}{Q} \cdot S$ $\dots(13.35)$

Therefore we conclude that making the galvanometer connection as at c , the resistance of leads does not affect the result.

The process described above is obviously not a practical way of achieving the desired result, as there would certainly be a trouble in determining the correct point for galvanometer connections. It does, however, suggest the simple modification, that two actual resistance units of correct ratio be connected between points m and n , the galvanometer be connected to the junction of the resistors. This is the actual Kelvin bridge arrangement, which is shown in Fig. 13.12.

The Kelvin double bridge incorporates the idea of a second set of ratio arms—hence the name double bridge—and the use of four terminal resistors for the low resistance arms. Fig. 13.12 shows the schematic diagram of the Kelvin bridge. The first of ratio arms is P and Q . The second set of ratio arms, p and q is used to connect the galvanometer to a point c at the appropriate potential between points m and n to eliminate the effect of connecting lead of resistance r between the known resistance, R , and the standard resistance, S .

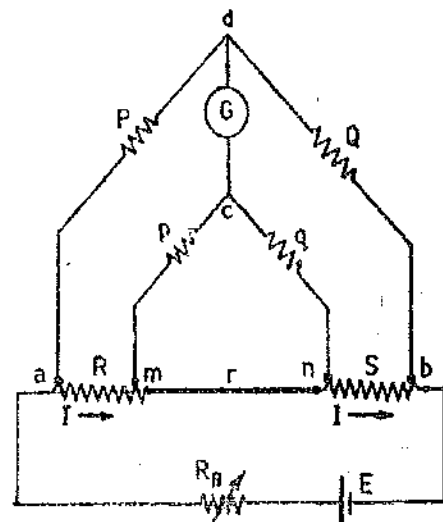

Fig. 13.12. Kelvin double bridge.

The ratio p/q is made equal to P/Q . Under balance conditions there is no current through the galvanometer, which means that the voltage drop between a and d , E_{ad} is equal to the voltage drop E_{amc} between a and c .

$$\text{Now, } E_{ad} = \frac{P}{P+Q} E_{ab}, \text{ and } E_{ab} = I \left[R+S + \frac{(p+q)r}{p+q+r} \right] \quad \dots(13'36)$$

$$\text{and } E_{amc} = I \left[R + \frac{p}{p+q} \left\{ \frac{(p+q)r}{p+q+r} \right\} \right] \quad \dots(13'37)$$

For zero galvanometer deflection, $E_{ad} = E_{amc}$

$$\text{or } \frac{P}{P+Q} I \left[R+S + \frac{(p+q)r}{p+q+r} \right] = I \left[R + \frac{p}{p+q} \left\{ \frac{(p+q)r}{p+q+r} \right\} \right]$$

$$\text{or } R = \frac{P}{Q} \cdot S + \frac{qr}{p+q+r} \left[\frac{P}{Q} - \frac{p}{q} \right] \quad \dots(13'38)$$

$$\text{Now, if } P/Q = p/q, \text{ Eqn. 13'38 becomes, } R = \frac{P}{Q} \cdot S \quad \dots(13'39)$$

Eqn. 13'39 is the usual working equation for the Kelvin bridge. It indicates that the resistance of connecting lead, r , has no effect on the measurement, provided that the two sets of ratio arms have equal ratios. Eqn. 13'38 is useful, however, as it shows the error that is introduced in case the ratios are not exactly equal. It indicates that it is desirable to keep r as small as possible in order to minimize the errors in case there is a difference between ratios P/Q and p/q .

The effect of thermo-electric emfs can be eliminated by making another measurement with the battery connections reversed. The true value of R being the mean of the two readings.

In a typical Kelvin bridge, the range of resistance covered is $0.1 \mu\Omega$ to 1.0Ω . The accuracies are as under :

From $1000 \mu\Omega$ to 1.0Ω ,..... 0.05% .

From $100 \mu\Omega$ to $1000 \mu\Omega$,..... 0.2% to 0.05% .

From $10 \mu\Omega$ to $100 \mu\Omega$,..... 0.5% to 0.2% , limited by thermoelectric emfs.

In this bridge there are four internal resistance standards of 1Ω , 0.1Ω , 0.01Ω and 0.001Ω respectively.

13'17. Kelvin Bridge Ohmmeter. This is a modified form of the Kelvin bridge and is intended for the rapid measurement of the winding resistances of machines and transformers, and for the measurement of contact and earth conductor resistances. The accuracy is of the order of $\pm 0.2\%$. This instrument is direct reading and the balance is obtained by rotating a single dial.

Fig. 13'13 gives the circuit diagram of a typical Kelvin bridge ohmmeter. The ratio arms P/Q and p/q of Fig. 13'12 are replaced by a combination of fixed resistors P and p and a double slide wire enabling the bridge ratio to be varied continuously between values $10/1$ to $200/1$.

Six standard resistors are used and these range from 0.01Ω to 1000Ω . The ratio dial is calibrated from 0.5Ω to $10^5 \Omega$ on the $\times 1$ range using 100Ω standard resistor. The overall range of the instrument is from 0.00005Ω to $10^5 \Omega$.

13'18. Unbalanced Kelvin Bridge. The galvanometer current of unbalanced Kelvin bridge can be found by the same Thevenin method as was used for Wheatstone bridge. The Thevenin source generator voltage, referring to Fig. 13'12 is :

$$E_o = E_{ad} - E_{amc}, \quad \text{where } E_{ad} = \frac{P}{P+Q} \cdot E_{ab} \quad \dots(13'40)$$

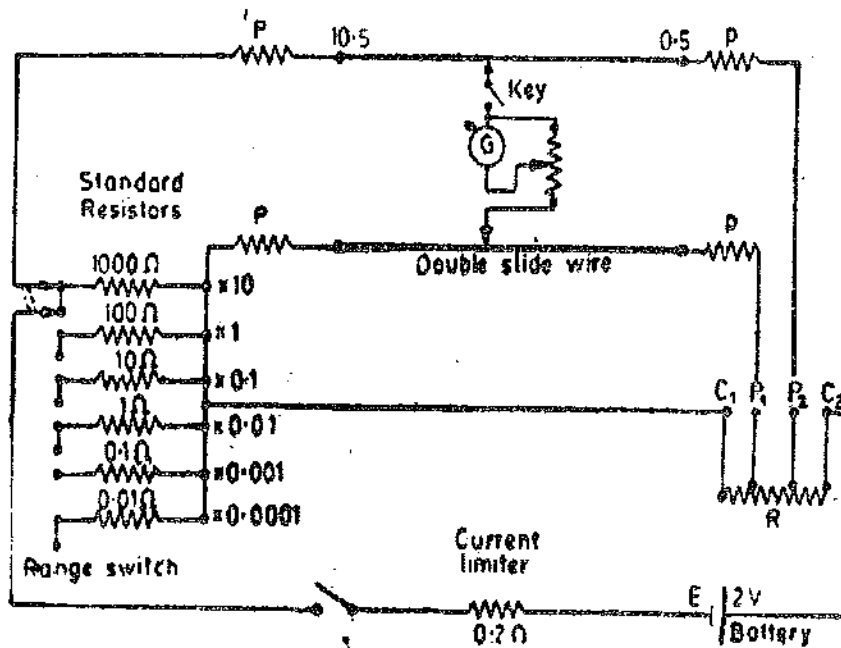

Fig. 13'13. Kelvian bridge ohmmeter.

$$E_{amo} = \frac{R + \frac{pr}{p+q+r}}{R + S + \frac{(p+q)r}{p+q+r}} E_{ab} \quad \dots(13'41)$$

The circuit for the Thevenin equivalent resistance as seen from galvanometer terminals *c* and *d* is shown in Fig. 13'14 (a) where R_0 is the resistance in the battery circuit.

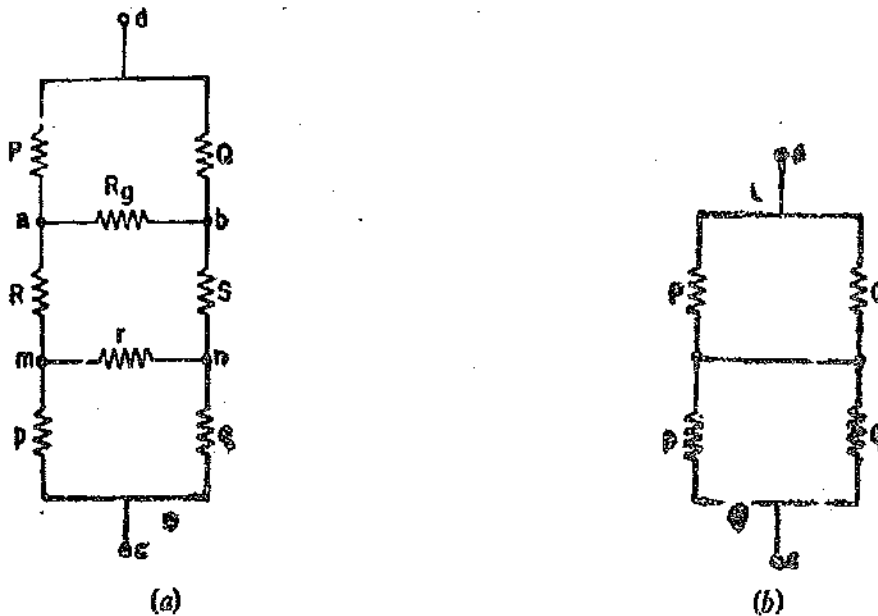

Fig. 13'14. Equivalent circuit for calculation of resistance of Kelvin bridge.

However, R, S, r and R_0 are usually very small and may be neglected with no appreciable loss in accuracy. The equivalent circuit then reduces to the one as shown in Fig. 13'14 (b). Therefore, Thevenin equivalent resistance

$$R_0 = \frac{PQ}{P+Q} + \frac{pq}{p+q} \quad \dots(13'42)$$

The galvanometer current $I_0 = \frac{E_0}{R_0 + G} \quad \dots(13'43)$

Example 13.14. A 4 terminal resistor of approximately $50 \mu\Omega$ resistance was measured by means of a Kelvin bridge having the following component resistances :

Standard resistor = $100.03 \mu\Omega$; Inner ratio arms = 100.31Ω and 200Ω ; outer ratio arms = 100.24Ω and 200Ω ; resistance of link connecting the standard and the unknown resistance = $700 \mu\Omega$. Calculate the unknown resistance to the nearest $0.01 \mu\Omega$.

Solution. From Eqn. 13.38 the unknown resistance

$$R = \frac{P}{Q} \cdot S + \frac{qr}{p+q+r} \left[\frac{P}{Q} - \frac{p}{q} \right]$$

$$= \frac{100.24}{200} \times 100.03 \times 10^{-6} + \frac{200 \times 700 \times 10^{-3}}{100.31 + 200 + 700 \times 10^{-6}} \left[\frac{100.24}{200} - \frac{100.31}{200} \right]$$

$$= 49.97 \times 10^{-6} \Omega = 49.97 \mu\Omega.$$

Example 13.15. A Kelvin double bridge (shown in Fig. 13.12) each of the ratio arms $P=Q=p=q=1000 \Omega$. The emf of the battery is 100 V and a resistance of 5Ω is included in the battery circuit. The galvanometer has a resistance of 500Ω and the resistance of the link connecting the unknown resistance to the standard resistance may be neglected. The bridge is balanced when the standard resistance $S=0.001 \Omega$.

- Determine the value of unknown resistance.
- Determine the current (approximate value) through the unknown resistance R at balance.
- Determine the deflection of the galvanometer when the unknown resistance, R , is changed by 0.1 percent from its value at balance. The galvanometer has a sensitivity of $200 \text{ mm}/\mu\text{A}$.

Solution. (a) At balance, the value of unknown resistance

$$R = \frac{P}{Q} \cdot S = \frac{1000}{1000} \times 0.001 = 0.001 \Omega.$$

(b) If we examine the Kelvin bridge circuit, we find that resistors P , Q and p , q are in parallel with the resistance of link, r . Since r is negligible and P , Q , p and q have large values, the effect of ratio arms can be neglected for the purpose of calculation of current.

\therefore Current under balance conditions

$$I = \frac{E}{R_B + R + S} = \frac{100}{5 + 0.001 + 0.001} \approx 20 \text{ A}$$

where

R_B = resistance in the battery circuit.

(c) The value R is changed by 0.1 per cent

\therefore New value of $R = 1.001 \times 0.001 = 0.001001 \Omega$.

Voltage between points a and b (Fig. 13.12)

$$E_{ab} = \frac{R+S+r}{R_B+R+S+r} \cdot E = \frac{R+S}{R_B+R+S} E \text{ as } r=0$$

$$\approx \frac{R+S}{R_B} = \frac{0.001 + 0.001001}{5} \times 100 = 40 \times 10^{-3}$$

From Eqns. 13.40 and 13.41 $E_o = E_{ad} - E_{abc}$

$$= \left(\frac{P}{P+Q} - \frac{R}{R+S} \right) E_{ab} = \left(\frac{1000}{1000+1000} - \frac{0.001001}{0.001+0.001001} \right) \times 40 \times 10^{-3}$$

$$= 0.01 \times 10^{-3} \text{ V} = 0.01 \text{ mV}.$$

Since R , S , r and R_0 are quite small as compared to P , Q , p and q , we can use circuit of Fig. 13.14 (b) for the calculation of internal resistance, R_0 , as viewed from terminals c and d .

$$R_0 = \frac{PQ}{P+Q} + \frac{pq}{p+q} = \frac{1000 \times 1000}{1000+1000} + \frac{1000 \times 1000}{1000+1000} = 1000 \Omega.$$

Galvanometer current

$$I_g = \frac{E_0}{R_0 + G} = \frac{0.01 \times 10^{-3}}{1000 + 500} = 0.0067 \times 10^{-6} \text{ A} = 0.0067 \mu\text{A}.$$

\therefore Deflection of galvanometer $\theta = S I_g = 200 \times 0.0067 = 1.34 \text{ mm}.$

MEASUREMENT OF HIGH RESISTANCE

13.19. Introduction. High resistances of the order of hundreds or thousands of megohm are often encountered in electrical equipment, and frequently must be measured. Common examples are :

- (i) insulation resistance of components and built up electrical equipment like machines and cables ;
- (ii) resistance of high resistance circuit elements like in vacuum tube circuits ;
- (iii) leakage resistance of capacitors ;
- (iv) volume resistivity of a material, *i.e.*, the resistance between two faces of unit area separated by unit distance with all conduction from face to face being through the body of the material ;
- (v) Surface resistivity, *i.e.*, the resistance between two lines of unit length and unit distance apart, the lines being on the surface of the material and all conduction being on the surface.

13.20. Difficulties in Measurement of High Resistances. High accuracy is rarely required in such measurements, hence simple circuits are used. Since the resistances under measurement have high values, very small currents are encountered in the measurement circuits. This aspect leads to several difficulties :

(i) The insulation resistance of the resistor may be comparable with the actual value of the resistor. Thus leakage currents are produced. These leakage currents are of comparable magnitude to the current being measured and must be eliminated from the measurement. Leakage currents no doubt introduce errors, but they generally vary from day to day, depending upon the humidity conditions and therefore cause additional unpredictable complications.

(ii) Due to electrostatic effect, stray charges can appear in the measuring circuit causing errors. Alternating fields can also effect the measurements considerably. Therefore, critical points of the measuring circuit must be carefully screened.

(iii) In order to obtain definite ratios in the potential distribution with respect to surroundings, one point of the circuit may be connected to earth for accuracy in measurements.

(iv) In measurement of insulation resistance the specimen often has considerable capacitance. On application of a direct voltage a large charging current flows initially which gradually decays down after a short interval. Further, insulating materials possess the property of dielectric absorption, *i.e.* after the main charging current has decayed down, further charge is slowly absorbed over a considerable period of time, perhaps for minutes or even hours. Thus measurement of true conduction current should be delayed until after the cessation of the charging and absorbing currents. But since the absorbing currents take a considerably long time to decay, it is usually inevitable that the conduction current measured includes some absorption current. The testing conditions, including the time between the application of voltage and observation of the current, must be specified.

(v) Fairly high voltages are used in tests in order to raise the currents to reasonable values

in order to be measured. So normally a sensitive galvanometer or micro-ammeter is required and adequate steps have to be taken to prevent damage to these delicate instruments.

A voltage supply of 100 V upto a few kV is often used depending upon the nature and breakdown voltage of the test object. The power supply unit is d.c. transistorized source. Proper smoothing and stabilization circuits are used to ensure constancy of voltage with time.

13'21. Use of Guard Circuit. Some form of guard circuits are generally used to eliminate the errors caused by leakage currents over insulation. Fig. 13'15 illustrates the operation of a guard circuit. In Fig 13'15 (a), a high resistance mounted on a piece of insulating material is measured by the ammeter-voltmeter method. The micro-ammeter measures the sum of the current through the resistor (I_R) and the current through the leakage path around the resistor (I_L). The measured value of resistance computed from the readings indicated on the voltmeter and the micro-ammeter, will not

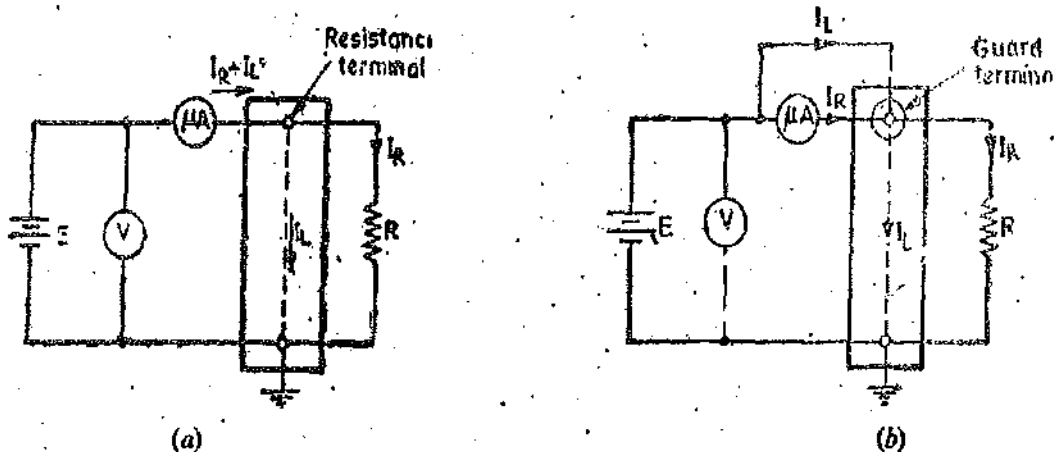

Fig. 13'15. Application of guard circuit for measurement of high resistance.

be true value but will be in error. In Fig. 13'15 (b) a guard terminal has been added to resistance terminal block. The guard terminal surrounds the resistance terminal entirely and is connected to the battery side of the micro-ammeter. The leakage current I_L , now bypasses the micro-ammeter which then indicates the current I_R through the resistor and thus allows the correct determination of the resistance value from the readings of voltmeter and microammeter. The guard terminal and resistance terminal are almost at the same potential and thus there will be no flow of current between them.

13'22. Methods for Measurement of High Resistance. The different methods employed are :

1. Direct deflection method.
2. Loss of charge method.
3. Megohm bridge.
4. Meggar (This is explained in Art. 8'25 on page 218).

13'23. Direct Deflection Method. The direct deflection method is basically that of Fig. 13'15 (b). For high resistances, such as insulation resistance of cables, a sensitive galvanometer of d'Arsonval type (usually having a current sensitivity of at 1000 mm/ μ A at a scale distance of 1 metre) is used in place of the microammeter. In fact many sensitive type of galvanometers can detect currents from 0.1–1 nA. Therefore, with an applied voltage of 1k V, resistances as high as 10^{12} to $10 \times 10^{12} \Omega$ can be measured.

An illustration of the direct deflection method used for measuring insulation resistance of a cable is shown in Fig. 13'16. The galvanometer G , measures the current I_R between the conductor and the metal sheath. The leakage current I_L , over the insulating material is carried by the guard wire wound on the insulation and therefore does not flow through the galvanometer.

Cables without metal sheaths can be tested in a similar way if the cable, except the end or

ends on which connections are made, is immersed in water in a tank. The water and the tank then form the return path for the current. The cable is immersed in slightly saline water for about 24 hours and the temperature is kept constant (at about 20°C) and then the measurement is taken as in Fig. 13.17.

The insulation resistance of the cable $R = \frac{V}{I_R}$.

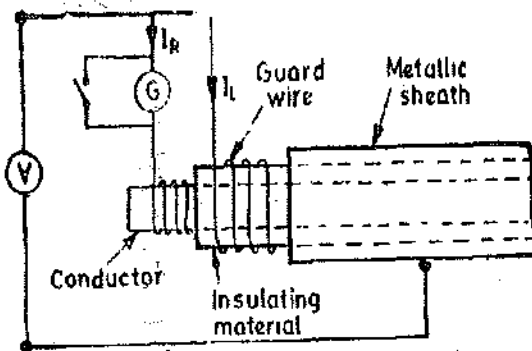

Fig. 13.16. Measurement of insulation resistance of cable having sheath.

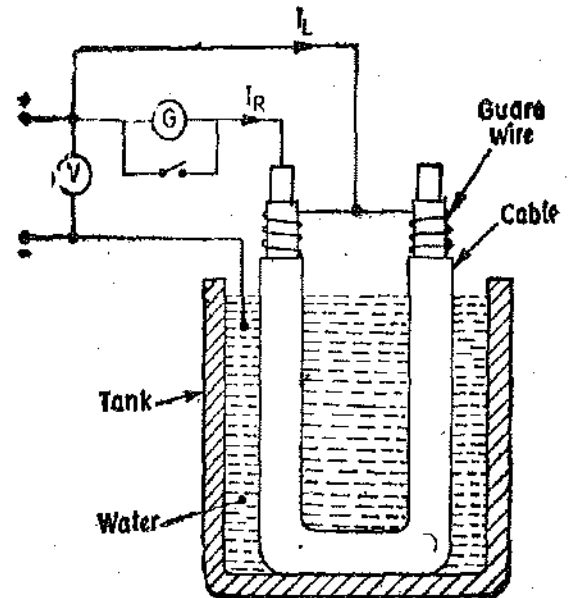

Fig. 13.17. Measurement of insulation resistance of cable having no conducting sheath.

In some cases, the deflection of the galvanometer is observed and its scale is afterwards calibrated by replacing the insulation by a standard high resistance (usually 1 MΩ), the galvanometer shunt being varied, as required to give a deflection of the same order as before.

In tests on cables the galvanometer should be short-circuited before applying the voltage. The short-circuiting connection is removed only after sufficient time has elapsed so that charging and absorption currents cease to flow. The galvanometer should be well shunted during the early stages of measurement, and it is normally desirable to include a protective series resistance (of several megohm) in the galvanometer circuit. The value of this resistance should be subtracted from the observed resistance value in order to determine the true resistance. A high voltage battery of 500 V emf is required and its emf should remain constant throughout the test.

Measurement of Volume and Surface Resistivity. The direct deflection method is often used for measurement of insulation resistance of insulating material samples available in sheet form. In such cases we are interested in the measurement of volume resistivity and the surface resistivity of the material.

Fig. 13.18 shows the schematic diagram for measurement of volume and surface resistivities of a specimen of insulating material. The specimen is provided with tin foil or colloidal graphite electrodes; the upper electrode having a guard ring. For measurement of volume resistivity (which in fact is the specific resistance) readings of voltage applied and the current through the galvanometer are taken. Leakage currents over the edge of the specimen will flow between the guard ring and the lower electrode and hence will not introduce error into the measurement. The volume resistivity, ρ , can be calculated as follows ;

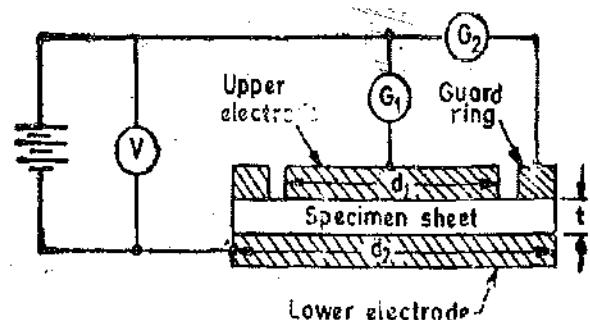

Fig. 13.18. Measurement of volume and surface resistivities of insulating material specimen

Let d_1 = diameter of the upper electrode disc,
 t = thickness of the specimen sheet, V_1 = reading of voltmeter
 and I_1 = current through galvanometer G_1 .

∴ Resistance of specimen $R = \frac{V_1}{I_1}$. But $R = \frac{\rho t}{\pi d_1^2}$.

∴ Volume resistivity of specimen, $\rho = \frac{\pi d_1^2 R}{t} = \frac{\pi d_1^2 V_1}{t I_1}$... (13'44)

If we want to measure surface resistivity, the galvanometer is placed in position G_2 . In this position the galvanometer measures the leakage current and current flowing between upper and lower electrodes will be eliminated from measurement. Let

d_2 = diameter of lower electrode disc, V_2 = reading of voltmeter
 and I_2 = current through galvanometer G_2 .

∴ Surface resistance $R_s = \frac{V_2}{I_2}$.

The leakage current flows along a path of length t and width πd_2 and therefore, surface resistivity,

$\rho_s = \frac{R_s \times \pi d_2}{t} = \frac{\pi d_2}{t} \cdot \frac{V_2}{I_2}$... (13'45)

Other forms of specimen and electrodes are also used. For example, the electrodes and guard ring may be mercury, either placed in specially machined recesses, in moulded insulating materials, or retained by metal rings on the surface of sheet materials.

13'24. Loss of Charge Method. In this method, (Fig. 13'19) the insulation resistance R , to be measured is connected in parallel with a capacitor C and a electrostatic voltmeter. The capacitor is charged to some suitable voltage, by means of a battery having voltage V and is then allowed to discharge through the resistance. The terminal voltage is observed over a considerable period of time during discharge.

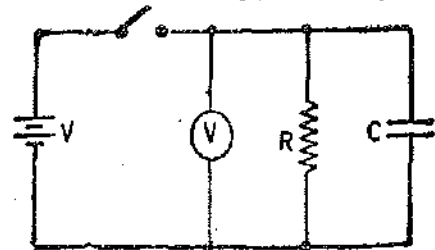

Fig. 13'19. Loss of charge method.

The voltage across the capacitor at any instant t after the application of voltage is

$v = Ve^{-t/CR}$ or $\frac{V}{v} = e^{t/CR}$

or Insulation resistance $R = \frac{t}{C \log_e V/v} = \frac{0.4343 t}{C \log_{10} V/v}$... (13'46)

The variation of voltage v with time shown in Fig. 13'20.

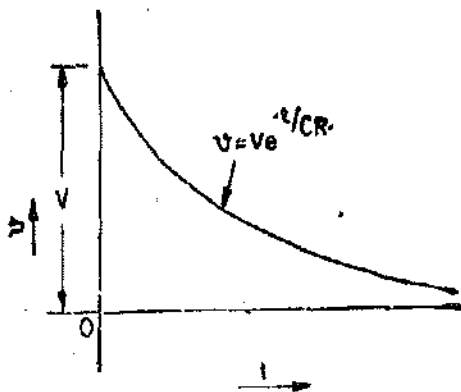

Fig. 13'20

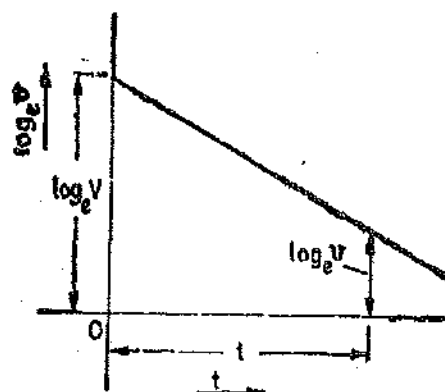

Fig. 13'21

From Eqn. 13'46 it follows that if V , v , C and t are known the value of R can be computed.

If the resistance R is very large the time for an appreciable fall in voltage is very large and thus this process may become time consuming. Also the voltage-time curve will thus be very flat and unless great care is taken in measuring voltages at the beginning and end of the time t , a serious error may be made in the ratio V/v causing a considerable corresponding error in the measured value of R . More accurate results may be obtained by change in the voltage $V-v$ directly and calling this change as e , the expression for R becomes :

$$R = \frac{0.4343 t}{C \log_{10} \frac{V}{V-e}} \quad \dots(13.47)$$

This change in voltage may be measured by a galvanometer.

However, from the experimental point of view, it may be advisable to determine the time t from the discharge curve of the capacitor by plotting curve of $\log_e v$ against time t . This curve is linear as shown in Fig. 13.21 and thus determination of time t from this curve for the voltage to fall from V to v yields more accurate results.

This method is applicable to some high resistances, but it requires a capacitor of a very high leakage resistance as high as the resistance being measured. The method is very attractive if the resistance being measured is the leakage resistance of a capacitor as in this case auxiliary R and C units are not required.

Actually in this method we do not measure the true value of resistance since we assume here that the value of resistance of electrostatic voltmeter and the leakage resistance of the capacitor have infinite value. But in practice corrections must be applied to take into consideration the above two resistances. Fig. 13.22 shows the actual circuit of the test where R_1 represents the leakage resistance of capacitor. Then if R' is the resistance of R_1 and R in parallel the discharge equation for capacitance gives

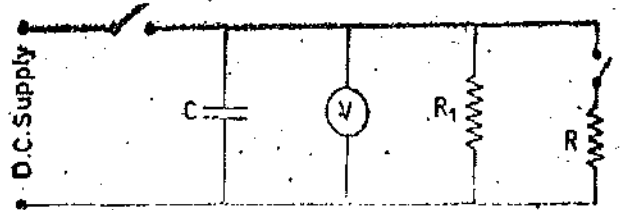

Fig. 13.22. Loss of Charge method considering effects of leakage resistance of capacitor.

$$R' = \frac{0.4343 t}{C \log_{10} V/v} \quad \dots(13.48)$$

The test is then repeated with the unknown resistance R , disconnected and the capacitor discharging through R_1 . The value of R_1 obtained from this second test and substituted into the expression

$$R' = \frac{R R_1}{R + R_1} \quad \dots(13.49)$$

in order to get value of R .

The leakage resistance of the voltmeter, unless very high should also be taken into consideration.

13.25. Megohm Bridge Method. Fig. 13.23 (a) shows a very high resistance R with its two main terminals A and B , and a guard terminal, which is put on the insulation. This high resistance may be diagrammatically represented as in Fig. 13.23 (b). The resistance R is between main terminals A and B and the leakage resistance R_{AG} and R_{BG} between the main terminals A and B of from a "Three terminal resistance".

Let us consider take the hypothetical case of a 100 MΩ resistance. We assume that each of the leakage resistances is 100 MΩ i.e. $R_{AG} = R_{BG} = 100$ MΩ. Let this resistance be measured by an ordinary Wheatstone bridge as shown in Fig. 13.24 (a). It is clear that the Wheatstone will bridge measure a resistance of $\frac{100 \times 200}{100 + 200} = 67$ MΩ instead of 100 MΩ thus giving an error of 33 percent.

However if the same resistance is measured by a modified Wheatstone bridge as shown in Fig. 13.24 (b) with the guard connection C connected as indicated the error in measurement is considerably reduced. For the arrangement shown in Fig. 13.24 (b) resistance R_{BG} is put in parallel with the galvanometer and thus it has no effect on the balance and only effects the sensitivity of the galvano-

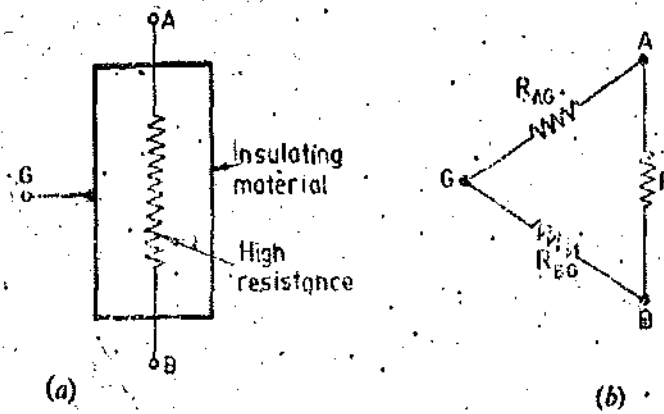

Fig. 13'23: Three Terminal Resistances.

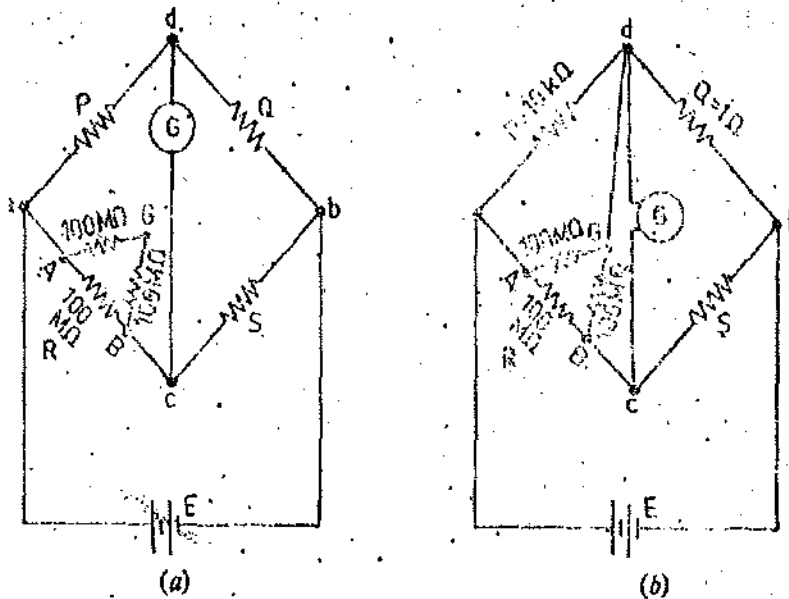

Fig. 13'24. Use of guard circuit for measurement of high resistance.

meter slightly. The resistance $R_{AG} = 100 \text{ M}\Omega$ is put in parallel with a resistance $P = 100 \text{ k}\Omega$ and therefore for the arrangement shown the measured value has an error of only 0.01 percent and this error is entirely negligible for measurements of this kind.

The arrangement of Fig. 13'24 (b) illustrates the operation of Megohm bridge.

Fig. 13'25 shows the circuit of a completely self-contained Megohm bridge which includes power supplies, bridge members, amplifiers, and indicating instrument. It has a range from $0.1 \text{ M}\Omega$ to $10^8 \text{ M}\Omega$. The accuracy is within 3% for the lower part of the range to possibly 10% above $10,000 \text{ M}\Omega$.

Sensitivity for balancing against high resistance is obtained by use of adjustable high voltage supplies of 500 V or 1000 V and the use of a sensitive null indicating arrangement such as a high gain amplifier with a vacuum tube or a transistor voltmeter or a cathode ray oscilloscope. The dial on Q is calibrated 1-10-100-1000 $\text{M}\Omega$, with main decade 1-10 occupying greater part of the dial space. Since unknown resistance $R = PS/Q$, the arm Q is

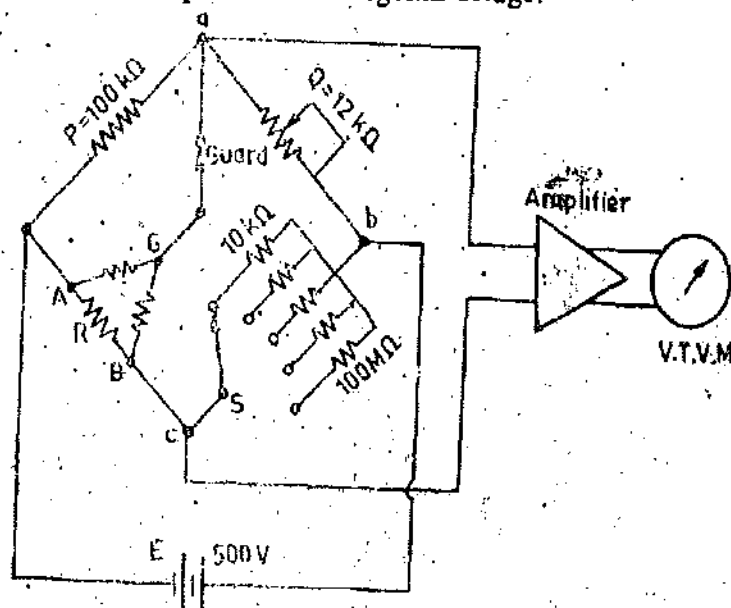

Fig. 13'25: Megohm bridge

made, tapered, so that the dial calibration is approximately logarithmic in the main decade, 1—10. Arm *S* gives five multipliers, 0.1, 1, 10, 100 and 1000.

The junction of ratio arms *P* and *Q* is brought on the main panel and is designated as 'guard' terminal.

13.26. Measurement of Insulation Resistance with Power On. In certain cases, it is necessary to measure the insulation resistance of the distribution system when the circuit is live. Fig. 13.26 shows the necessary arrangement of the two wire d.c. distribution system. Two voltage measurements

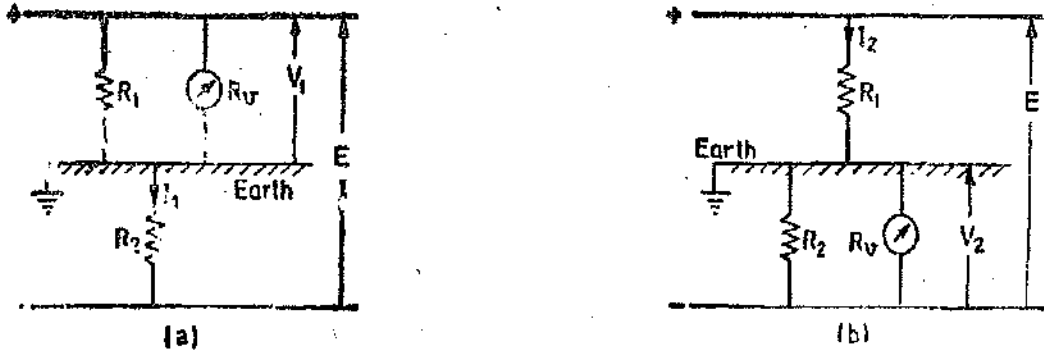

Fig. 13.26. Measurement of insulation resistance when power is on.

are done first with voltmeter connected between positive main and the ground [Fig. 13.26 (a)] and the second with voltmeter connected between negative main and ground [Fig. 13.26 (b)]. Let

R_1 = insulation resistance between positive main and earth,

R_2 = insulation resistance between negative main and earth,

R_v = resistance of the voltmeter,

V_1 = measured voltage between positive main and earth,

V_2 = measured voltage between negative main and earth,

and

E = measured voltage between positive main and negative main.

If I_1 is the current flowing from positive main to negative main in Fig. 13.26 (a),

we have $E = \left(\frac{R_1 R_v}{R_1 + R_v} + R_2 \right) I_1 = \left(\frac{R_1 R_v + R_1 R_2 + R_2 R_v}{R_1 + R_v} \right) I_1$ and $V_1 = \left(\frac{R_1 R_v}{R_1 + R_v} \right) I_1$.

$$\therefore \frac{E}{V_1} = \frac{R_1 R_v + R_1 R_2 + R_2 R_v}{R_1 R_v} \quad \dots (i)$$

$$\text{Similarly} \quad \frac{E}{V_2} = \frac{R_1 R_v + R_1 R_2 + R_1 R_v}{R_2 R_v} \quad \dots (ii)$$

Therefore from (i) and (ii) we have: $\frac{V_2}{V_1} = \frac{R_2}{R_1}$ or $R_2 = R_1 \frac{V_2}{V_1}$.

Substituting this value of R_2 in (i),

$$\frac{E}{V_1} = \frac{R_1 \frac{V_2}{V_1} (R_1 + R_v) + R_1 R_v}{R_1 R_v} = \frac{R_1 \frac{V_2}{V_1} + R_v \frac{V_2}{V_1} + R_v}{R_v}$$

$$\text{or} \quad R_1 = R_v \frac{E - (V_1 + V_2)}{V_2} \quad \dots (13.50)$$

$$\text{Similarly,} \quad R_2 = R_v \frac{E - (V_1 + V_2)}{V_1} \quad \dots (13.51)$$

These measurements must be made with a high resistance voltmeter whose resistance, R_v , should be comparable with the insulation resistances being measured.

This method cannot be used if one of the mains is earthed, and is generally applicable if the insulation resistances to be measured are more than 1 or 2 M Ω .

Example 13'16. Drive an expression for insulation resistance of single core cable. The conductor of a cable has a diameter of 5 mm and the overall diameter of the cable is 25 mm. If the insulation resistance of the cable is 16,000 Ω /km, calculate the specific resistance of insulating material.

Solution. Let d = diameter of conductor,

D = diameter of insulated cable,

L = length of cable,

and ρ = resistivity of insulating material.

Let us consider an annular ring of width dx at a radius x from the centre as shown in Fig. 13'27. Insulation resistance of this annular ring is :

$$dR_x = \frac{\rho dx}{2\pi xL}$$

\therefore Total insulation resistance of cable

$$R = \int_{d/2}^{D/2} \frac{\rho dx}{2\pi xL}$$

$$= \frac{\rho}{2\pi L} \log_e \frac{D}{d} = \frac{2.303 \rho}{2\pi L} \log_{10} \frac{D}{d} = \frac{0.367}{L} \rho \log_{10} \frac{D}{d}$$

Now in this example we have

$D = 25 \times 10^{-3}$ m ; $d = 5 \times 10^{-3}$ m ; $L = 1$ km = 1000 m and $R = 16,000 \Omega$.

$$\text{Specific resistance } \rho = \frac{RL}{0.367 \log_{10} D/d} = \frac{16000 \times 1000}{0.367 (\log_{10} 2.5/0.5)} = 62.5 \times 10^{-6} \Omega\text{-m.}$$

Example 13'17. A test voltage is applied for several minutes between the conductor of a 400 metre length of cable and earth. The galvanometer connected in series reads 250 divisions, the value of universal shunt being 2.5 with a standard resistance of 1 M Ω in circuit, the scale reading is 350, the value of shunt being 1000. Calculate the insulation resistance of the cable. What would be the insulation resistance of the same cable of length 100 metre ?

Solution. Since we have a universal shunt with the galvanometer and therefore the current through the circuit is proportional to the deflection of the galvanometer times universal shunt multiplier. Deflection of galvanometer with unknown resistance ' R ' is circuit 250 divisions and the shunt multiplier is 2.5.

\therefore Current through the circuit with unknown resistance connected is :

$$I_R K \times 250 \times 2.5 = 625 K \text{ where } K \text{ is a constant.}$$

Deflection of galvanometer with standard resistance ' S ' in circuit is 350 divisions and the shunt multiplier is 1000.

\therefore Current through the circuit with standard resistance connected is :

$$I_S = K \times 350 \times 1000 = 350,000 K$$

Now $I_R R = I_S S = E$, where E = voltage of the source,

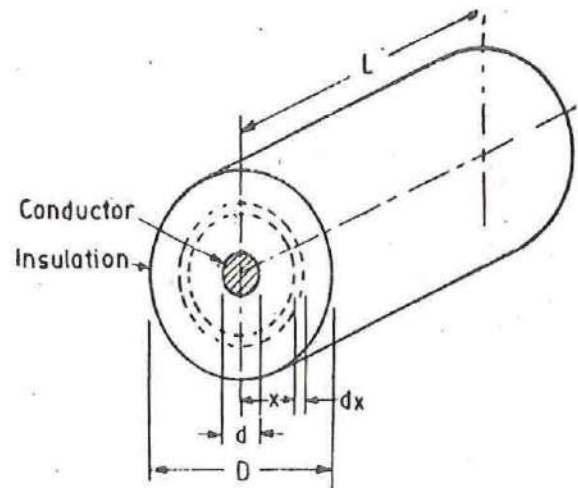

Fig. 13'27. Insulated cable.

∴ Insulation resistance of 400 metre long cable

$$R = \frac{I_s}{I_b} \cdot S = \frac{350,000 \text{ K}}{625 \text{ K}} \times 1 = 560 \text{ M}\Omega.$$

The insulation resistance is inversely proportional to length of cable and therefore insulation resistance of 1000 metre long cable

$$= 560 \times \frac{400}{1000} = 224 \text{ M}\Omega$$

Example 13'18. A length of cable is tested for insulation resistance by the loss of charge method. An electrostatic voltmeter of infinite resistance is connected between the cable conductor and earth, forming therewith a joint capacitance of 600 pF. It is observed that after charging the voltage falls from 250 V to 92 V in 1 minute. Calculate the insulation resistance of the cable.

Solution. From Eqn. 13'46 insulation resistance of cable :

$$R = \frac{0.4343 t}{C (\log_{10} V/v)} = \frac{0.4343 \times 60}{600 \times 10^{-12} (\log_{10} 250/92)} = 100 \times 10^9 \Omega = 100,000 \text{ M}\Omega.$$

Example 13'19. A cable is tested by loss of charge method using a ballistic galvanometer, with following results : Discharged immediately after electrification, deflection 200 divisions. Discharged after 30 s and after electrification : (i) deflection 126 divisions, (ii) when in parallel with a resistance of 10 MΩ, deflection 100 divisions. Calculate the insulation resistance of the cable.

Solution. Suppose R is the insulation resistance of the cable and let R' be the resultant resistance of parallel combination of insulation resistance, R and the 10 MΩ resistance.

$$\therefore R = \frac{0.4343 \times 30}{C \log_{10} 200/126} = \frac{0.4343 \times 30}{0.201 C} \quad \text{and} \quad R' = \frac{0.4343 \times 30}{C \log_{10} 200/100} = \frac{0.4343 \times 30}{0.301 C}$$

$$\text{Thus we have : } \frac{R'}{R} = \frac{0.201}{0.301} = 0.667. \quad \text{or} \quad R' = 0.667 R.$$

$$\text{Now } R' = \frac{R \times 10}{R + 10} \quad \text{or} \quad 0.667 R = \frac{R \times 10}{R + 10} \quad \therefore R = 5 \text{ M}\Omega.$$

Example 13'20. The following voltage readings were taken with a 250 V, 1000 Ω/V voltmeter.

Between mains, 218 V ; positive main to earth, 188 V ; negative main to earth, 10 V.
Calculate the insulation resistance of each main.

Solution. Resistance of voltmeter, $R_v = 250 \times 1000 = 250,000 \Omega$.

From Eqn. 13'50, insulation resistance of positive main

$$R_1 = R_v \frac{E - (V_1 + V_2)}{V_2} = 250 \times 10^3 \times \frac{218 - (188 + 10)}{10} = 500 \times 10^3 \Omega = 0.5 \text{ M}\Omega.$$

From Eqn. 13'51, insulation resistance of negative main,

$$R_2 = R_v \frac{E - (V_1 + V_2)}{V_1} = 250 \times 10^3 \times \frac{218 - (188 + 10)}{188} = 26.6 \times 10^3 \Omega = 0.266 \text{ M}\Omega.$$

UNSOLVED PROBLEMS

1. A voltmeter of resistance 500 Ω and a milliammeter of 1.0 Ω resistance are used to measure a resistance by ammeter-voltmeter method. If the voltmeter reads 20 V and the milliammeter 100 mA, calculate the value of

measured resistance (*i*) if the voltmeter is put across the resistance and the milliammeter connected series in (*ii*) if the voltmeter is put across the resistance only. [Ans. 199 Ω ; 333 Ω]

2. In a laboratory a voltmeter of 200 Ω resistance and an ammeter of 0.02 Ω resistance are available. Calculate the value of resistance that can be measured by the ammeter voltmeter method for which the two different circuit measurements give equal errors. [Ans. 2 Ω]

3. In a measurement of resistance by the substitution method, a standard resistance of 100 kΩ is used. The galvanometer has a resistance of 2000 Ω, and gives the following deflections :

- (i) With unknown resistance—46 divisions,
- (ii) With standard resistance—40 divisions.

Find the value of unknown resistance. [Ans. 86.7 kΩ]

4. The four arms of a Wheatstone bridge are as follows :

$$AB=100 \Omega ; BC=10 \Omega ; CD=4 \Omega \text{ and } DA=50 \Omega.$$

The galvanometer has a resistance of 20 Ω and is connected across *BD*. A source of 10 V d.c. is connected across *AC*. Find the current through the galvanometer. What should be the resistance in the arm *DA* for 10 current through the galvanometer ? [Ans. 5.15 mA ; 40 Ω]

5. The four arms of a Wheatstone bridge are as follows :

$$AB=100 \Omega ; BC=1000 \Omega ; CD=4000 \Omega \text{ and } DA=400 \Omega.$$

The galvanometer has a resistance of 100 Ω, a sensitivity of 100 mm/μA and is connected across *AC*. A source of 4 V d.c. is connected across *BD*. Calculate the current through the galvanometer and its deflection if the resistance of arm *DA* is changed from 400 Ω to 401 Ω. [Ans. 1.63 μA ; 16.3 mm]

6. In a Wheatstone bridge, the ratio arms *AB*=10 Ω and *BC*=100 Ω ; standard-resistance across *CD*=10 Ω. The shunt across 10 Ω ratio arm has to be changed from 22310 to 27670 Ω, when the resistor *R*₂ was changed for *R*₁ in the arm *DA*. Calculate in magnitude the difference between the resistances of *R*₁ and *R*₂. The bridge is balanced in both the cases. [Ans. 86.8 μΩ]

7. A modified Wheatstone bridge network is constituted as follows :

AB is a resistance *P* in parallel with resistance *p* ; *BC* is a resistance *Q* in parallel with a resistance *q* ; *CD* and *DA* are resistances *R* and *S* respectively. The nominal values of *P*, *Q* and *S* are each 10 Ω. With resistance *R* in circuit, balance is obtained with *p*=30,000 Ω and *q*=25,000. With *R* replaced by a standard resistance of 10 Ω, balance is obtained when *p*=15,000 Ω and *q*=40,000 Ω. Calculate the value of *R*. [Ans. 9.99952 Ω]

8. A Wheatstone bridge is used to measure the resistance of a resistor. The bridge was balanced with the values shown in Fig. 13.28. It is found that, due to presence of chemical impurities emfs are set up at points *x*₁ and *x*₂ of respective values 12 mV and 22 mV with polarities being shown in the diagram. Calculate ;

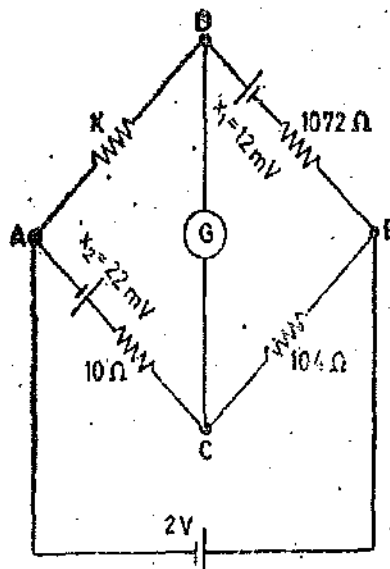

Fig. 13.28

- (i) the apparent value of *X*, (ii) the true of *X*,
- (iii) the % error in the apparent value of *X*. [Ans. 103 Ω ; 115.7 Ω ; -12.3%]

9. A Kelvin bridge is balanced with the following constants : Outer ratio arm 100 Ω and 1000 Ω ; Inner arms, ratio 99.92 Ω and 1000.6 Ω ; Resistance of link, 0.1 Ω ; Standard resistance, 0.00377 Ω.

Calculate the value of unknown resistance. [Ans. 0.000467 Ω]

10. The ratio arms of a Kelvin bridge are 100Ω each. The galvanometer has an internal resistance of 500Ω and a current sensitivity of $200 \text{ mm}/\mu\text{A}$. The unknown resistance is 0.1002 and the standard resistance is set at 0.1000Ω . A d.c. current of 10 A is passed through the standard and the unknown resistance from a 2.2 V battery in series with a rheostat.

Calculate the deflection of the galvanometer. Neglect the resistance of the link. Find also the resistance unbalance to produce a deflection of 1 mm . [Ans. 3320 mm ; $0.6 \mu\Omega$]

11. Calculate insulation resistance of a cable in which the voltage falls from 100 to 80 V in 20 s . The capacitance is 300 pF . [Ans. $298000 \text{ M}\Omega$]

12. A cable immersed in a testing tank is charged to a voltage of 200 V , an electrostatic voltmeter being connected between core and tank. After one minute's electrification, the cable and voltmeter are isolated and is found that in 20 s the voltage falls to 150 V . The test is repeated with a resistance of $20 \text{ M}\Omega$ between core and tank and the voltage is found to fall to 100 V in the same time. Calculate the insulation resistance of the cable, that of the voltmeter being given as $50 \text{ M}\Omega$. [Ans. $64 \text{ M}\Omega$]

13. The following observations were made for a loss of charge method for the determination of a high resistance R . The charged capacitor of capacitance $12.5 \mu\text{F}$ was connected across an electrostatic voltmeter and R in parallel, and the voltage measured after intervals of time.

time, s	0	100	200	300	400	500	600
voltage, V	150	121	97	83	65	57	34

A further set of readings was taken with resistor R removed from circuit, as follows :

time, s	0	200	400	600
voltage, V	150	143	133	121

The readings of voltmeter were subject to large random errors. Calculate an accurate value of resistance R . [Ans. $52.5 \text{ M}\Omega$]

14. A high resistance of $200 \text{ M}\Omega$ has a leakage resistance of $400 \text{ M}\Omega$ between each of its main terminals and the guard terminal. Find the percentage error in measurement if the above resistance is measured by an ordinary Wheatstone bridge without providing guard circuit. [Ans. 20% low]

15. Two mains are working at potential difference of 220 V . A 250 V voltmeter having $10,000 \Omega/\text{V}$ when connected between positive main and earth reads 149 V and the reading is 42 V when connected between negative main and earth. Calculate the insulation resistance of each main with respect to earth. [Ans. 1.73 and $0.486 \text{ M}\Omega$]

Potentiometers

D.C. POTENTIOMETERS

14'1. Introduction. A potentiometer is an instrument designed to measure an unknown voltage by comparing it with a known voltage. The known voltage may be supplied by a standard cell or any other known voltage—reference source (See Art. 4'29 page 95). Measurements using comparison methods are capable of a high degree of accuracy because the result obtained does not depend upon the actual deflection of a pointer, as is the case in deflectional methods, but only upon the accuracy with which the voltage of the reference source is known.

Another advantage of the potentiometers is that since a potentiometer makes use of a balance or null condition, no current flows and hence no power is consumed in the circuit containing the unknown emf when the instrument is balanced. Thus the determination of voltage by a potentiometer is quite independent of the source resistance.

Since in potentiometer measures voltage, it can also be used to determine current simply by measuring the voltage drop produced by the unknown current passing through a known standard resistance.

The potentiometer is extensively used for a calibration of voltmeters and ammeters and has in fact become the standard for the calibration of these instruments. For the above mentioned advantages the potentiometer has become very important in the field of electrical measurements and calibration.

14'2. Basic Potentiometer Circuit.

The principle of operation of all potentiometers is based on the circuit of Fig. 14'1, which shows the schematic diagram of the basic slide wire potentiometer.

With switch 'S' in the "operate" position and the galvanometer key *K* open, the battery supplies the "working current" through the rheostat *R* and the slide wire. The working current through the slide wire may be varied by changing the rheostat setting. The method of measuring the unknown voltage, *E*, depends upon finding a position for the sliding contact such the galvanometer shows zero deflection, *i.e.*, indicates null condition, when the galvanometer key, *K*, is closed. Zero galvanometer deflection or a null means that the unknown voltage, *E*, is equal to the voltage drop E_1 across portion *ac* of the slide wire. Thus determination of the value of unknown voltage now becomes a matter of evaluating the voltage drop E_1 along the portion *ac* of the slide wire.

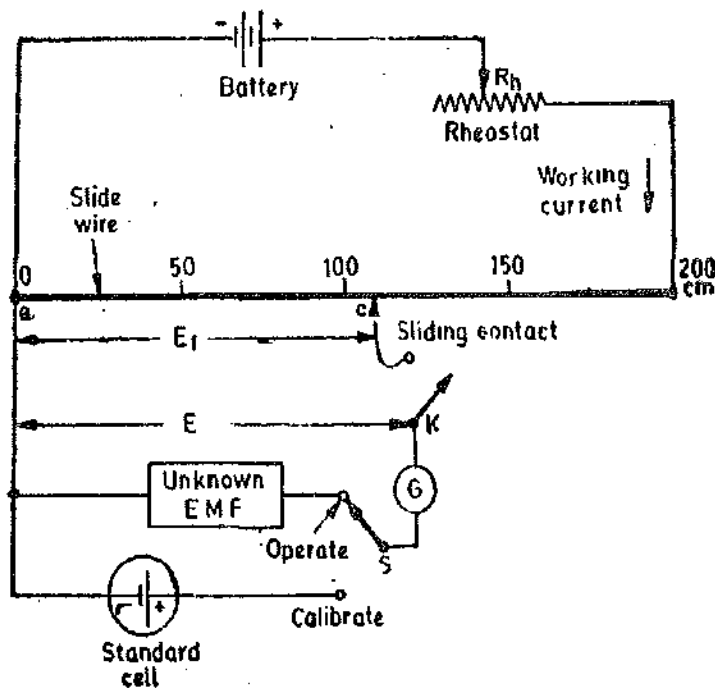

Fig. 14'1. Circuit diagram of a basic slide wire potentiometer.

The slide wire has a uniform cross-section and hence uniform resistance along its entire length. A calibrated scale in cm and fractions of cm, is placed along the slide wire so that the sliding contact can be placed accurately at any desired position along the slide wire. Since the resistance of slide wire is known accurately, the voltage drop along the slide wire can be controlled by adjusting the value of working current. The process of adjusting the working current so as to match the voltage drop across a portion of sliding wire against a standard reference source is known as "Standardisation".

Standardisation. The procedure for standardisation of the potentiometer is illustrated by the following example :

The slide wire of Fig. 14.1 has a total length of 200 cm and a resistance of 200 Ω . The emf of the standard cell is 1.0186 V. Switch 'S' is thrown to "calibrate" position and the sliding contact is placed at 101.86 cm mark on the slide wire scale. The rheostat *R* is now adjusted so as to vary the working current. This adjustment is carried on till the galvanometer shows no deflection when key 'K' is pressed. Under these conditions, the voltage drop along the 101.86 cm portion of slide wire is equal to standard cell voltage of 1.0186 V. Since the 101.86 cm portion of the slide wire has a resistance of 101.86 Ω , the working current in fact has been adjusted to a value :

$$\frac{1.0186}{101.86} \times 1000 = 10 \text{ mA.}$$

The voltage at any point along the slide wire is proportional to the length of slide wire. This voltage is obtained by converting the calibrated length into the corresponding voltage, simply by placing the decimal point in the proper position e.g. 153.6 cm. = 1.536 V. If the potentiometer has been calibrated once, its working current is never changed.

14.3. Laboratory type (Crompton's) Potentiometer. The slide-wire type of potentiometer described in Art. 14.2 is not a practical form of construction. The long slide wire is awkward, and even for the length shown cannot be read to a very great degree of precision. Modern laboratory type potentiometers use calibrated dial resistors and a small circular wire of one or more turns, thereby reducing the size of the instrument. The circuit of a simple laboratory type potentiometer is shown in Fig. 14.2. There is one dial switch with fifteen steps, each having a precision resistor. There is also a single turn circular slide wire. For the case shown, the resistance of slide wire is 10 Ω and the dial resistors have a value of 10 Ω each. Thus the dial has a total resistance of 150 Ω and in addition the slide wire has a resistance of 10 Ω . The working current of the potentiometer is 10 mA and therefore each step of dial switch corresponds to 0.1 V. The slide wire is provided with 200 scale divisions and since the total resistance of slide wire corresponds to a voltage drop of 0.1 V, each division of slide wire corresponds to $0.1/200 = 0.0005$ V. It is quite comfortable to interpolate readings upto 1/5 of a scale division and therefore with this potentiometer it is possible to estimate the readings upto 0.0001 V.

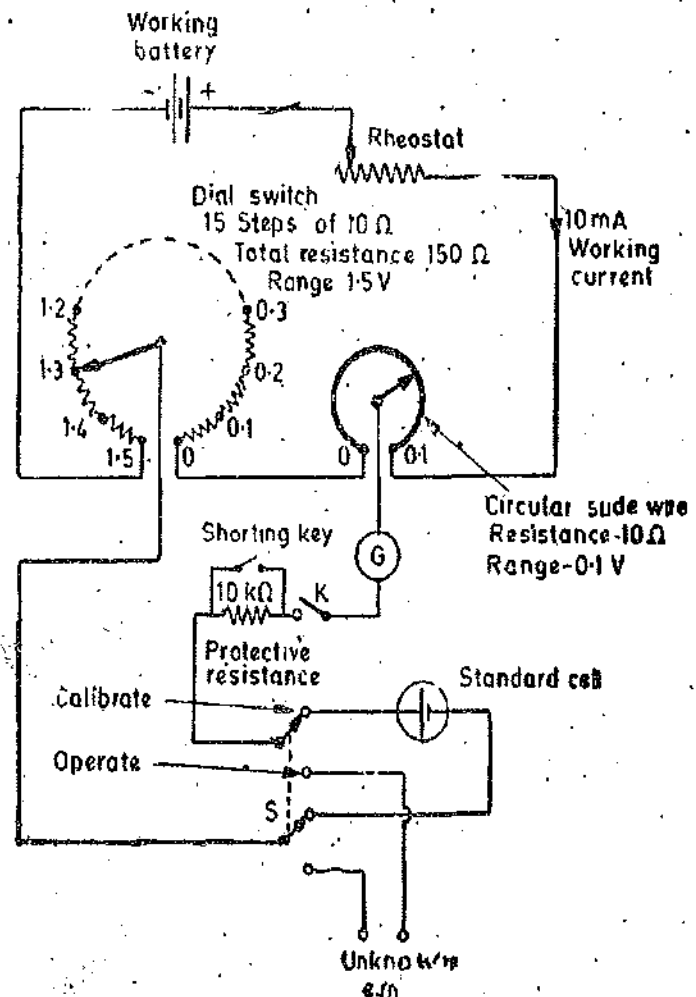

Fig. 14.2. Laboratory type potentiometer.

This potentiometer is provided with a double throw switch which allows the connection

of either the standard cell or the unknown emf to be applied to the working circuit. A key and a protective resistance (usually about $10\text{ k}\Omega$) is used in the galvanometer circuit. In order to operate the galvanometer at its maximum sensitivity provision is made to short the protective resistance when near the balance conditions.

The following steps are used when making measurements with the above potentiometer :

1. The combination of dial resistors and the slide wire is set to the standard cell voltage. Supposing the value of emf of standard cell is 1.0186 V , the dial resistor is put at 1.0 V and the slide wire is put at 0.0186 setting.

2. The switch S is thrown to the calibrate position and the galvanometer key is tapped while the rheostat is adjusted for zero deflection on the galvanometer. The protective resistance is kept in the circuit in the initial stages so as protect the galvanometer from being getting damaged.

3. As the balance or null point is approached, the protective resistance is shorted so as to increase the sensitivity of the galvanometer. Final adjustments are made for zero deflection with the help of the rheostat.

This completes the standardisation process for the potentiometer.

4. After completion of standardisation, the switch ' S ' is thrown to operate position thereby connecting the unknown emf into the potentiometer circuit. With the protective resistance in the circuit, the potentiometer is balanced by means of the main dial and the slide wire.

5. As the balance is approached, the protective resistance is shorted, and final adjustments are made to obtain true balance.

6. The value of unknown emf is read off directly from the settings the of dial and the slide wire.

7. The standardisation of the potentiometer is checked again by returning the switch S to the calibrate position. The dial settings are kept exactly the same as in the original standardisation process. If the new reading does not agree with the old one, a second measurement of unknown emf must be made. The standardisation should be again checked after the completion of measurement. This potentiometer is a form of Crompton's Potentiometer.

14.4. Multiple-Range Potentiometer. The single-range potentiometer shown in Fig. 14.2 is frequently constructed to cover a range of 1.6 V —though, of course, it can be designed for any desired voltage within reasonable and practical limits. For example a Crompton's potentiometer is designed to measure voltages upto 1.9 V by simply adding three more resistance steps to the main dial.

The circuit of a single potentiometer may be modified in a simple way to add a second range, which is usually by a second factor, such as 0.1 or 0.01 , in order that the direct reading features of the original circuit may still be utilized.

Fig. 14.3 shows the schematic diagram of a duo-range (two range) potentiometer. The two ranges are obtained by using two resistors R_1 and R_2 and a range selecting switch S . The operation of duo-range potentiometer of Fig. 14.3 may be more easily understood and analyzed by redrawing in its simplified form by omitting the galvanometer and calibration (standardizing) circuit. The simplified diagram is shown in Fig. 14.4.

In Fig. 14.4 the total resistance of measuring of circuit, R_m , consists of resistance of main dial in series with that of slide wire. The main dial has fifteen steps of $10\ \Omega$ each and therefore it has a total resistance of $150\ \Omega$. The resistance of slide wire is $10\ \Omega$. The measuring circuit current I_m must be equal to 10 mA in order to produce a voltage drop of 1.6 V across the measuring circuit resistance R_m i.e. resistance of the main dial and the slide wire in series. The diagrams 14.3 and 14.4, with the range switch S in $\times 1$ position, represent an identical arrangement as shown in Fig. 14.2. When the range switch S is thrown to position $\times 0.1$, the measuring current I_m must be reduced to $1/10$ of its original value i.e. 1 mA in order to produce a voltage drop of 0.16 V across the measuring circuit resistance R_m .

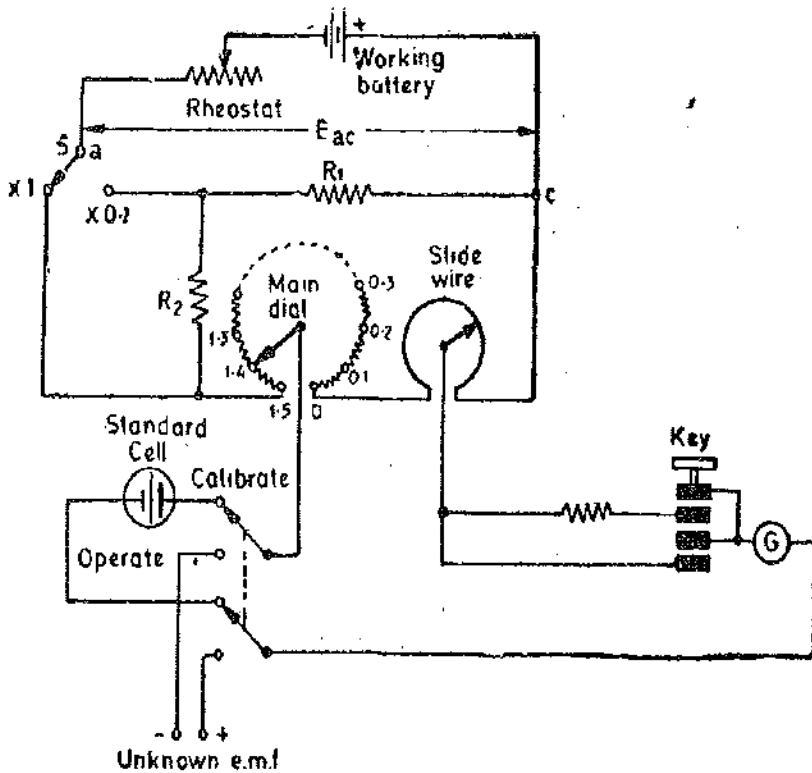

Fig. 14.3. Duo-range type potentiometer.

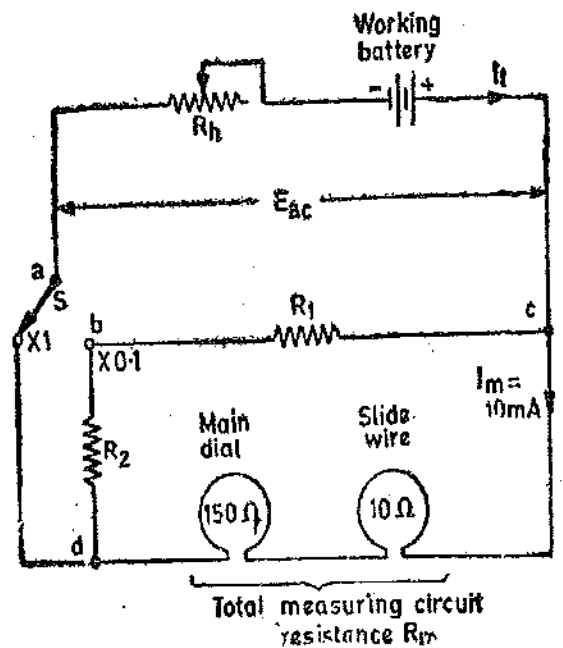

Fig. 14.4. Simplified diagram of a duo-range potentiometer.

The design of circuit of a duo-range potentiometer should be such that it is possible to change the measuring ranges without re-adjusting the rheostat or changing the value of working voltage of the battery. This is essential so that once the instrument has been calibrated on $\times 1$ range, calibration of the $\times 0.1$ range is not necessary. The above requirement means that the voltage E_{ac} in Fig. 14.4 remains the same for both positions of range switch S . This condition is satisfied only when the total battery current has the same value for each measuring range.

In order to analyse the operation of duo-range potentiometer of Fig. 14.4, we draw simple circuit diagrams for the two ranges. Fig. 14.5 shows the circuit for $\times 1$ range while Fig. 14.6 shows the circuit for $\times 0.1$ range.

On range $\times 1$ (Fig. 14.5), the range resistors R_1 and R_2 are in parallel with total measuring resistance R_m . On the $\times 0.1$ range (Fig. 14.6), the range resistor R_1 is in parallel with the series combination of R_2 and R_m .

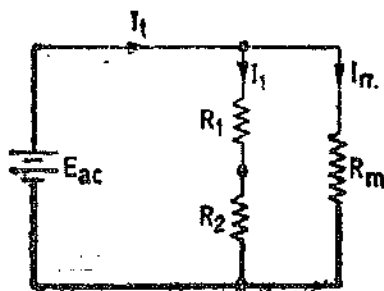

Fig. 14.5. Circuit for $\times 1$ range.

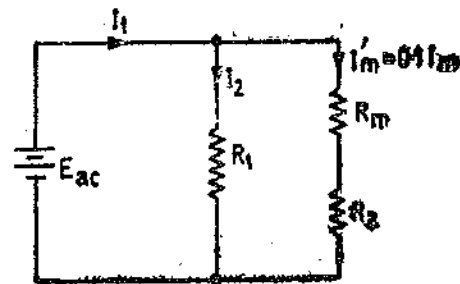

Fig. 14.6. Circuit for $\times 0.1$ range.

In order that the total current I_t drawn from the battery is the same, we must have

$$\frac{R_m(R_1 + R_2)}{R_1 + R_2 + R_m} = \frac{R_1(R_m + R_2)}{R_1 + R_2 + R_m}$$

or $R_2 R_m = R_1 R_2$ or $R_1 = R_m$.

This means that range resistance R_1 must equal the resistance of the measuring circuit in order that the total current drawn from the battery is the same for both the ranges.

Now current through the measuring circuit on $\times 0.1$ range should be $1/10$ of the current in the measuring circuit on $\times 1$ range.

This means that $I_{m'} = 0.1 I_m$.

$$\text{Now } I_m = \frac{E_{ac}}{R_m} \quad \dots(i)$$

$$\text{and } I_{m'} = \frac{E_{ac}}{R_m + R_2} \quad \text{or } 0.1 I_m = \frac{E_{ac}}{R_m + R_2} \quad \dots(ii)$$

From (i) and (ii), we have : $0.1(R_m + R_2) = R_m$

$$R_2 = 9 R_m = 9 R_1.$$

For the circuit of Fig. 14.4, where measuring circuit resistance $R_m = 160 \Omega$, we have :

$$R_1 = R_m = 160 \Omega, \quad \text{and } R_2 = 9 R_m = 1440 \Omega.$$

With this arrangement the total current drawn from the battery is 11 mA for each of the two ranges.

The above mentioned potentiometer measures voltages upto 1.6 V on $\times 1$ range and upto 0.16 V on the $\times 0.1$ range. On the lower range the dial readings are simply multiplied by the range factor of 0.1 to get the voltage being measured. If the slide wire has 100 scale divisions and each division can be interpolated to one fifth of a division, the resolution of the potentiometer is :

$$\frac{1}{5} \times \frac{1}{100} \times 0.01 \text{ V} = 20 \mu\text{V}, \text{ on the } \times 0.1 \text{ range.}$$

The duo-range potentiometer has two distinct advantages in having the low range for small voltages :

- (i) precision of reading is increased by one decimal place,
- and (ii) a greater part of reading is made on the dial resistors which have inherently a greater accuracy than the slide wire.

The duo-range potentiometer given in Fig. 14.3 is constructed for a voltage ratio of 10 : 1. A similar arrangement may be used for any other ratio by proper selection of range resistors R_1 and R_2 . Precision laboratory type of potentiometers often have three voltage ranges usually of 1.0, 0.1 and 0.01.

14.5. Constructional Details of Potentiometers. All the resistors in a potentiometer, with the exception of slide wires are made of manganin. This is because manganin has a high stability, a low temperature co-efficient and has freedom from thermo-electric effects against copper.

The slide wire is usually made of platinum-silver alloy and the sliding contacts are of a copper-gold-silver alloy. This combination of materials for slide wire and sliding contacts results in a good contact, freedom from thermo-electric emfs and minimum wear of slide wire.

The current controlling rheostat is usually a combination of a stud dial and a multturn slide wire.

It is very important that internal thermo-electric emfs in a potentiometer are minimum. The use of manganin resistors helps in this direction. It is desirable that all the parts work at the same temperature. Therefore, all the parts are covered in a single case. This has the added advantage of protecting the contacts from fumes and dust which may cause corrosion and appearance of volatic emf's at the joints. Potentiometers designed specially for thermocouple measurements have copper terminals.

In order to prevent leakage, all the parts must be enclosed, so as to protect them from moisture. The working parts are normally mounted on ebonite or keramot panels.

14'6. Precision type Potentiometers. The potentiometers described so far are simple instruments capable of a precision of $100 \mu\text{V}$ for readings upto 1.6 V . The difficulties to get accurate results mainly arise because of lack of uniformity of slide wire and the difficulties in maintaining the contacts in good shape. However, for some applications higher precision and accuracy are needed, requiring changes in design features. Some of the features are explained below :

14'7. Vernier Potentiometer. The limitations imposed, on performance of ordinary potentiometers by slide wire are eliminated in a vernier potentiometer. This instrument has two ranges : the normal range of 1.6 V down to $10 \mu\text{V}$ and a lower range of 0.16 V down to $1 \mu\text{V}$.

This potentiometer uses the Kelvin Varley arrangement shown in Fig. 14'7. However, in this potentiometer there are three measuring dials. The first dial measures upto 1.5 V (on the XI range) in steps 0.1 V ; the middle dial has 102 studs and reads upto 0.1 V in steps of 0.001 V ; the third dial also has 102 studs and reads from -0.0001 V to 0.001 V in steps of 0.00001 V (i.e., $10 \mu\text{V}$). There is no slide wire. The resistances of the middle dial shunt two of the coils of first dial. The moving arm of middle dial carries two arms spaced two studs apart. In actual practice the resistance of second dial is greater than that between two studs in the main (first) dial, so that the voltage drop across the second dial is greater than 0.1 V . If this is not done the voltage drop in switch contact resistances and leads would render the converge of middle dial to less than 0.1 V . The third deal is obtained from a shunt circuit which permits a true zero and a small negative setting to be obtained.

The vernier potentiometer reads to increment of 0.00001 V ($10 \mu\text{V}$) on range XI and has readability of $1 \mu\text{V}$ on $\times 0.1$ range. If a third range of $\times 0.01$ is provided, the readability becomes $0.1 \mu\text{V}$. This does not mean, unfortunately, that small voltages can be read with assurance to $0.1 \mu\text{V}$. Measurements are subject to stray thermal and contact emfs in the potentiometer, galvanometer and the measuring circuits. These emfs may be of the order of one to several microvolt and are difficult to locate and control. These emfs can be minimized only by special construction i.e., proper selection of metals for resistors, terminals and connecting leads and also by the use of thermal shields.

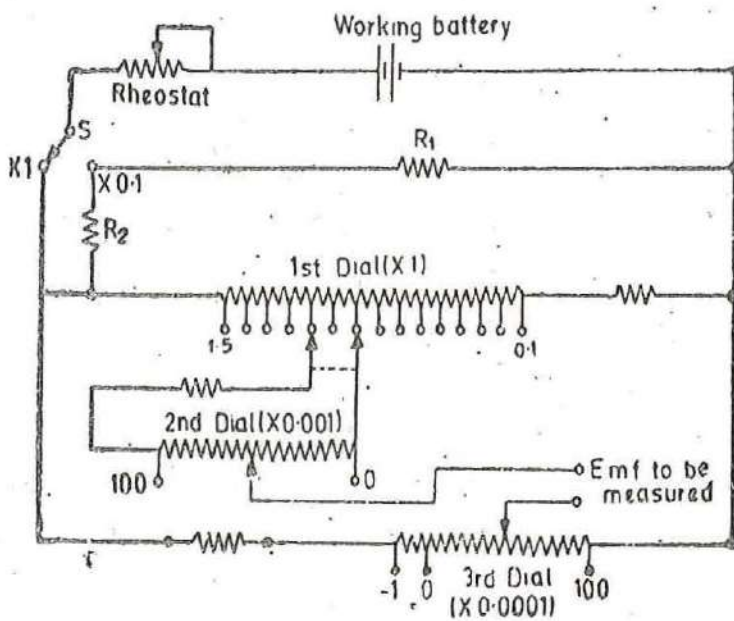

Fig. 14'7. A duo-range vernier potentiometer.

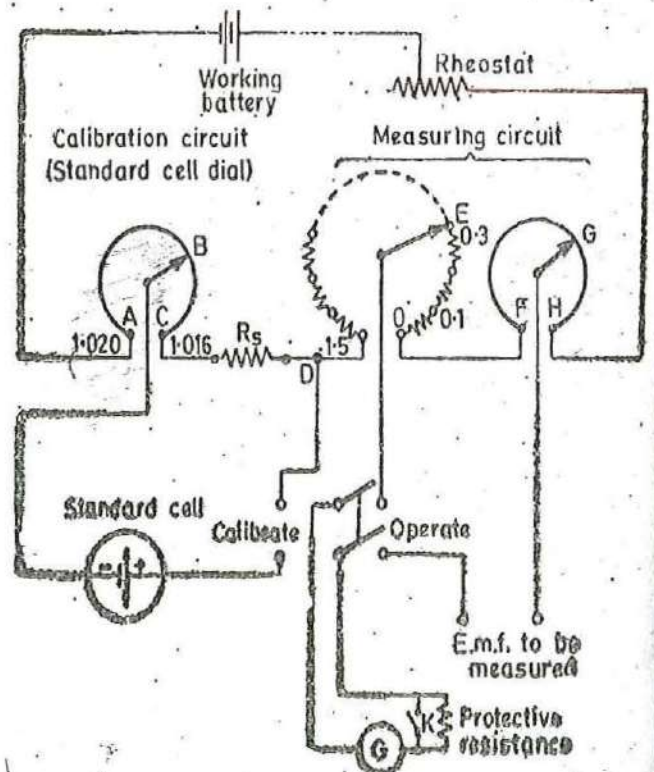

Fig. 14'8. Single range potentiometer using independent calibrating circuit.

14'8. Standard Cell Dial. All modern potentiometers incorporate a separate standard cell dial circuit (calibrating circuit).

This provides a means of standard cell balance resistance to suit the emf value of the particular standard cell used. Also a separate standard cell dial permits the operator to check the standard cell balance at any time during the course of measurement without disturbing the potentiometer setting. Fig. 14'8 shows a separate standard cell dial incorporated in a single range potentiometer.

This potentiometer is provided with an independent standardizing circuit *AD* which can be set on any range of standard cell emf from 1'016 V to 1'020 V. A drop of 1'016 V is provided by resistance *R_s* and the remaining drop of 0'004 V is provided by the slide wire *AC*. Thus a considerable change in standard cell emf owing to temperature changes can be allowed for the operation of circuit, Fig. 14'8. The slide wire of calibrating circuit is set to read the emf of the standard cell which is connected to the potentiometer. The selector switch *S* is put at the calibrate position and the rheostat is adjusted, so that there is no current flowing through the galvanometer. This fixes the working current to its proper value. The switch *S* is then thrown to the operate position and unknown emf is read by adjusting the measuring circuit dial and slide wire.

The standardizing circuit may be checked for constancy of working current, any time during the measurements by simply throwing the switch *S* back to calibrate position. This process does not disturb the measuring circuit while convenience and speed of measurements is increased.

14'9. True Zero. In the student type potentiometers described in Art. 14'2 it is impossible to obtain true zero because the two contacts cannot coincide absolutely. This drawback is eliminated in the simplified circuit of Fig. 14'9. The slide wire *BC* is provided with a shunt resistor which is tapped at *D*. This tapping is made *O* on the main dial. When the contact is in a position such that $\frac{r_1}{r_3} = \frac{r_2}{r_4}$ there is no potential difference between zero stud and 0 hence the slide wire has a true zero. The slider can travel a little lower than zero position giving a small negative reading. The movement of slider above zero gives positive reading. The range of slide wire is usually from -0'005 V to +0'105 V.

14'10. Brooks Deflectional Potentiometer. This potentiometer is used for applications where the voltage to be measured is continuously changing. With conventional type of potentiometers it becomes impossible to obtain exact balance even when the changes are slow since it is difficult to follow the changes by manipulation of the dials.

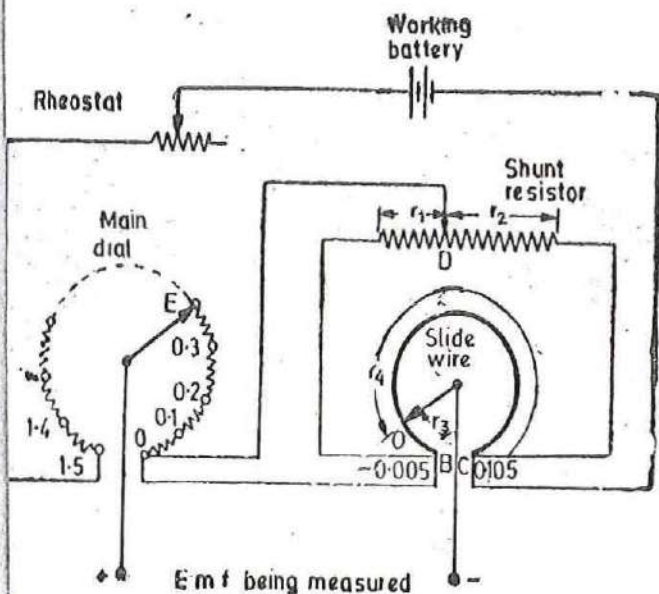

Fig. 14'9. Potentiometer with true zero.

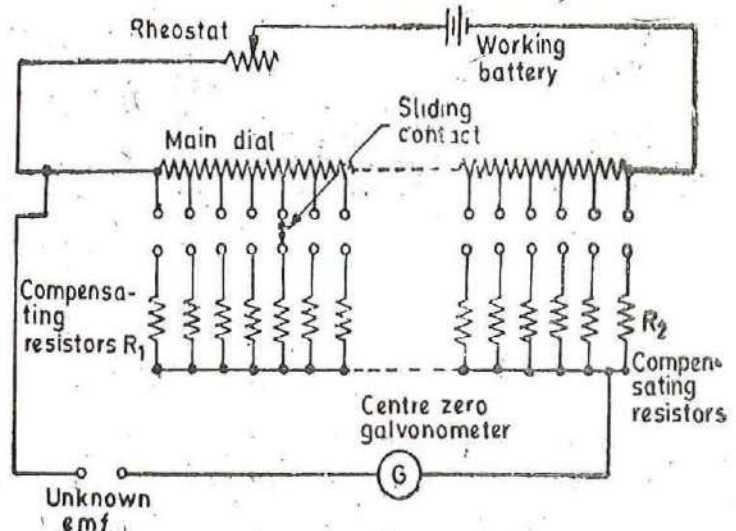

Fig. 14'10. Deflectional Potentiometer.

Fig. 14.10 shows a deflectional potentiometer. In this potentiometer only one or two main dials, consisting of decade resistance boxes, are used. A centre zero type galvanometer is included in the circuit to indicate deflection. The galvanometer circuit includes a set of compensating resistors R_1, R_2 . The values of the compensating resistors is such that the resistance of the potentiometer circuit, as viewed from terminals where the unknown emf is applied, remains constant irrespective of the position of the sliding contacts. This means that current through the galvanometer will always be proportional to the out of balance current whatever may be the setting of the main dials. Thus the galvanometer scale can be calibrated to read the out of balance emf directly. The value of the unknown emf is obtained by adding the galvanometer reading to the main dial setting. The main dial setting is kept nearly equal to the emf being measured.

The potentiometer is used to monitor the value of temperature where a thermocouple is employed. The output of the thermocouple is fed to the unknown emf terminals.

Reasonably rapid changes in galvanometer indication can be followed with ease which are impossible to take with conventional potentiometers.

Example 14.1. A simple slide wire is used for measurement of current in a circuit. The voltage drop across a standard resistor of 0.1Ω is balanced at 75 cm. Find the magnitude of the current if the standard cell emf of 1.45 V is balanced at 50 cm.

$$\text{Solution : Voltage drop per unit length} = \frac{1.45}{50} = 0.029 \text{ V/cm.}$$

$$\text{Voltage drop across 75 cm length} = 0.029 \times 75 = 2.175 \text{ V.}$$

$$\therefore \text{Current through resistor } I = \frac{2.175}{0.1} = 21.75 \text{ A.}$$

Example 14.2. A basic slide wire potentiometer has a working battery voltage of 3.0 V with negligible internal resistance. The resistance of slide wire is 400Ω and its length is 200 cm. A 200 cm scale is placed along the slide wire. The slide wire has 1 mm scale divisions and it is possible to read upto $1/5$ of a division. The instrument is standardized with 1.018 V standard cell with sliding contact at the 101.8 cm mark on scale. Calculate (a) working current, (b) the resistance of series rheostat, (c) the measurement range and (d) the resolution of instrument.

Solution : (a) Since the instrument is standardized with an emf of 1.018 V with sliding contact at 101.8 cm; it is obvious that a length 101.8 cm represents a voltage of 1.018 V.

$$\text{Resistance of 101.8 cm length of wire} = \frac{101.8}{200} \times 400 = 203.6 \Omega$$

$$\therefore \text{Working current } I_m = \frac{1.018}{203.6} = 0.005 \text{ A} = 5 \text{ mA.}$$

(b) Total resistance of the battery circuit = resistance of rheostat + resistance of slide wire

$$\therefore \text{Resistance of rheostat } R_h = \text{total resistance} - \text{resistance of slide wire}$$

$$= \frac{3}{5 \times 10^{-3}} - 400 = 600 - 400 = 200 \Omega.$$

(c) The measurement range is the total voltage across the slide wire.

$$\therefore \text{Range of voltage} = (5 \times 10^{-3}) \times 400 = 2.0 \text{ V}$$

(d) A length of 200 cm represents 2.0 volts and therefore 1 mm represents a voltage of

$$\frac{2.0}{200} \times \frac{1}{10} \text{ V} = 1.0 \text{ mV}$$

Since it is possible to read $1/5$ of 1 mm. Resolution of instrument is $1/5 \times 1 = 0.2 \text{ mV}$.

Example 14.3. A single range student type potentiometer has a 18 step dial switch where each step represents 0.1 V. The dial resistors are 10 Ω each. The slide wire of the potentiometer is circular and has 11 turns and a resistance of 11 Ω . The slide wire has 100 divisions and interpolation can be done to one fourth of a division. The working battery has a voltage of 6.0 V and negligible internal resistance. Calculate (a) the measuring range of potentiometer, (b) the resolution, (c) working current, and (d) setting of rheostat.

Solution : (a) Total resistance of measuring circuit

$$R_m = \text{resistance of dial} + \text{resistance of slide wire} = 18 \times 10 + 11 = 191 \Omega$$

Since each step of 10 Ω represents a voltage drop of 0.1 V, range of instrument

$$= 191 \times \frac{0.1}{10} = 1.91 \text{ V.}$$

(b) The slide wire has a resistance of 11 Ω and therefore voltage drop across slide wire

$$= 11 \times \frac{0.1}{10} = 0.11 \text{ V.}$$

The slide wire has 11 turns and therefore voltage drop across each turn

$$= \frac{0.11}{11} = 0.01 \text{ V.}$$

Each turn is divided into 100 divisions and therefore each division represents a voltage drop of

$$\frac{0.01}{100} = 0.0001 \text{ V.}$$

Since each turn can be interpolated to $\frac{1}{4}$ of a division,

$$\therefore \text{Resolution of instrument} = \frac{1}{4} \times 0.0001 \text{ V} = 0.000025 \text{ V} = 25 \mu\text{V.}$$

(c) The voltage drop across working circuit of potentiometer is 1.91 V and the resistance is 191 Ω .

$$\therefore \text{Working current } I_m = \frac{1.91}{191} = 0.001 \text{ A} = 10 \text{ mA.}$$

$$(d) \text{ Total resistance across battery circuit} = \frac{6.0}{10 \times 10^{-3}} = 600 \Omega.$$

The resistance of potentiometer working circuit is 191 Ω .

$$\therefore \text{Resistance of series rheostat } R_h = 600 - 191 = 409 \Omega.$$

Example 14.4. A duo-range potentiometer is designed for two ranges : X 1 and X 0.1. The circuit of Fig. 14.3 is used. The main dial consists of 15 steps of 20 Ω each, and the slide wire has a resistance of 30 Ω . The standard cell voltage is 1.019 V. The potentiometer is designed to have a measuring range of 1.65 V d.c. on the X 1 range. Calculate (a) the value of measuring current on each range, (b) the resistance of range resistors R_1 and R_2 , (c) the current supplied by battery for each range, and (d) the resistance of rheostat if the battery has a voltage of 6.0 V.

Solution : (a) An examination of the data shows that if we assume each step of dial resistor to represent 0.1 V, the voltage drop across the main dial is $0.1 \times 15 = 1.5 \text{ V}$. Now each step has a resistance of 20 Ω and therefore voltage drop across the 30 Ω slide wire = $\frac{30}{20} \times 0.1 = 0.15 \text{ V}$.

Therefore total voltage drop across the measuring circuit = $1.5 + 0.15 = 1.65 \text{ V}$.

Thus to design a 1.65 V potentiometer, each step of main dial should represent 0.1 V.

Total resistance of measuring circuit $R_m = 15 \times 20 + 30 = 330 \Omega$.

∴ Measuring circuit current on X 1 range, $I_m = \frac{1.65}{330} = 0.005 \text{ A} = 5 \text{ mA}$.

(b) The simplified circuits of X 1 and X 0.1 range potentiometers are given in Figs. 14.5 and 14.6. The analysis is also given along side which can be referred to.

∴ $R_1 = R_m = 330 \Omega$ and $R_2 = 9R_1 = 9 \times 330 = 2970 \Omega$.

Range : X1

Referring to Fig. 14.5,

Current $I_1 = \frac{I_m R_m}{R_1 + R_2} = \frac{(5 \times 10^{-3}) \times 330}{330 + 2970} = 0.5 \times 10^{-3} \text{ A} = 0.5 \text{ mA}$.

Total battery current $I_t = I_m + I_1 = 5 + 0.5 = 5.5 \text{ mA}$.

Range : X 0.1

Referring to Fig. 14.6, working current $I_m' = 0.1 I_m = 0.1 \times 5 = 0.5 \text{ mA}$.

Current $I_2 = \frac{I_m' (R_m + R_2)}{R_1} = \frac{0.5 \times 10^{-3} (330 + 2970)}{330} = 5 \times 10^{-3} \text{ A} = 5 \text{ mA}$.

Total battery current $I_t = I_m' + I_2 = 0.5 + 5 = 5.5 \text{ mA}$.

(d) Voltage drop across working circuit = 1.65 V

Voltage of battery = 6.00 V

Voltage drop across rheostat = 6.00 - 1.65 = 4.35 V

Battery current = $5.5 \times 10^{-3} \text{ A}$

∴ Resistance of rheostat $R_h = \frac{4.35}{5.5 \times 10^{-3}} = 791 \Omega$.

14.11. **Volt-Ratio Box.** General purpose potentiometers cover a maximum voltage range of approximately 0-1.6 V in case of American Instruments and 0-1.8 V in case of British Instruments. If higher voltage ranges have to be measured a precision potential divider, called a volt-ratio box, is used. The volt-ratio box provides multiple ranges as shown in Fig. 14.11.

The voltage to be measured is connected to the appropriate binding post. Sometimes the volt-ratio box is provided with selector switch for voltage ranges. Supposing the voltage to be measured is connected between common terminal and 300 V switch. If the reading of the potentiometer is 0.826, then the value of unknown voltage is $0.826 \times \frac{300}{1.5} = 165.2 \text{ V}$.

It was stated earlier that the potentiometer consumes no power from the source under balance conditions. However, when a volt-ratio box is used, this statement is no longer true. An examination of Fig. 14.11 indicates that a current must flow through resistance R , in order to produce a voltage drop so that a voltage measurement be made by the potentiometer in order that the unknown voltage be determined. Therefore, the resistance of the volt-ratio box represents a load on the unknown voltage source and thus consumes power. The value of volt-ratio box

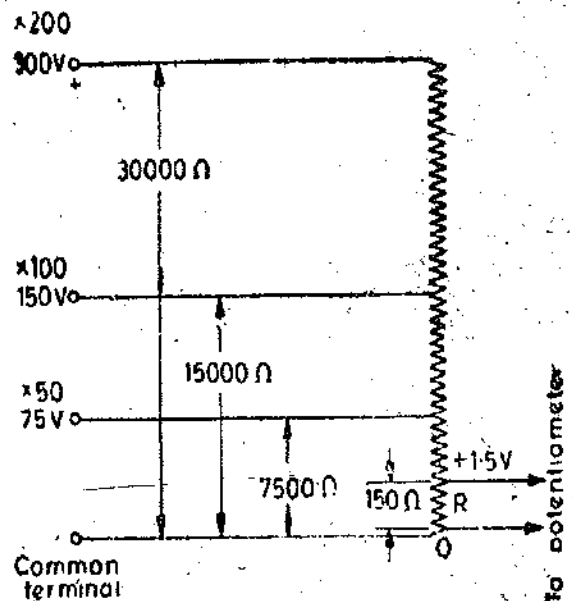

Fig. 14.11. Volt-Ratio box.

resistance should be as high as possible in order that the power consumption is low. However, low values of resistance are preferred since they have a greater degree of stability. Also low values of resistance give greater galvanometer sensitivity and also minimize the effects of high resistance leakage paths around the terminals.

Thus the choice of volt-ratio box resistance involves a compromise between low and high values. Volt-ratio boxes are usually constructed with resistances of 100 Ω/V or 200 Ω/V of the nominal voltage range, allowing a maximum current of 10 mA or 5 mA respectively from the measured source. Fig. 14'11 shows a volt-ratio box with a resistance of 100 Ω/V and a maximum current of 10 mA.

14.12. Application of D.C. Potentiometers. In addition to measurement of voltage, the potentiometer is the usual basis for calibration of all voltmeters, ammeters and wattmeters. The potentiometer may also be used for measurement of current, power and resistance. Since the potentiometer is a d.c. device, the instruments to be calibrated must be d.c. or electro-dynamometer types.

1. Calibration of Voltmeter. Fig. 14'12 shows the circuit for calibration of a voltmeter. The foremost requirement in this calibration process is that a suitable stable d.c. voltage supply is available since any changes in the supply voltage will cause a corresponding change in the voltmeter calibration.

Fig. 14'12 shows a potential divider network, consisting of two rheostats, one for coarse and the other for fine control of calibrating voltage. These controls are connected to the supply source and with the help of these controls it is possible to adjust the voltage so that the pointer coincides exactly

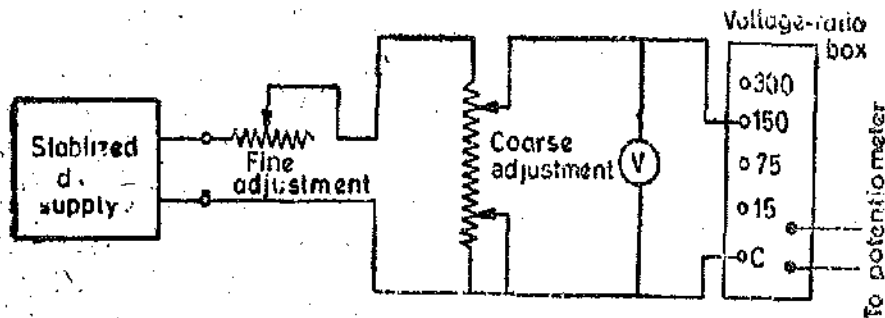

Fig. 14'12. Calibration of voltmeter with potentiometer.

with a major division of the voltmeter. The voltage across the voltmeter is stepped down to a value suitable for application to a potentiometer with the help of a volt-ratio box. For accuracy of measurements, it is necessary to measure voltages near the maximum range of the potentiometer, as far as possible.

Thus if a potentiometer has a maximum range of 1.6 V, to achieve high accuracy we will have to use low voltage ranges for voltages less than 1.6 V and use appropriate tappings on volt-ratio box for voltages higher than 1.6 V.

The potentiometer measures the true value of voltage. If the potentiometer reading does not agree with the voltmeter reading, a negative or positive error is indicated. A calibration curve may be drawn with the help of the readings of voltmeter and potentiometer.

2. Calibration of Ammeter. Fig. 14'13 shows the circuit for calibrating an ammeter. A standard resistance of suitable value and sufficient current carrying capacity is placed in series with the ammeter under calibration. The voltage across the standard resistor is measured with the help of potentiometer and the current through the standard resistance (and hence the ammeter) can be computed.

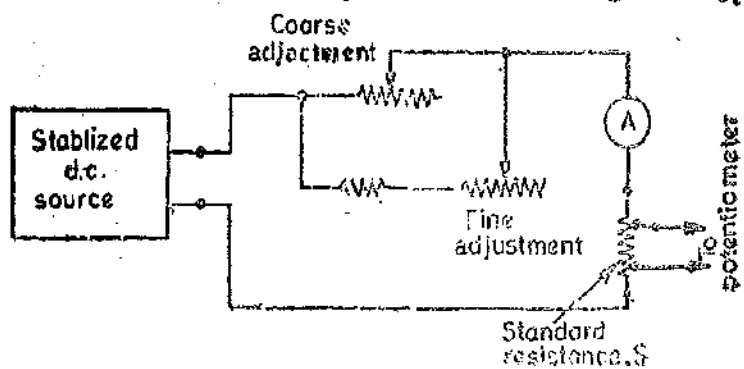

Fig. 14'13. Calibration of an ammeter with potentiometer.

$$\text{Current } I = \frac{V_s}{S}$$

where V_s = voltage across the standard resistor as indicated by the potentiometer,
and S = resistance of standard resistor.

Since the resistance of the standard resistor is accurately known and the voltage across the standard resistor is measured by a potentiometer, this method of calibrating an ammeter is very accurate. A calibration curve indicating the errors at various scale readings of the ammeter may be plotted.

3. Measurement of Resistance. The circuit of measurement of resistance with a potentiometer is shown in Fig. 14.14. The unknown resistance, R , is connected in series with a standard resistor S .

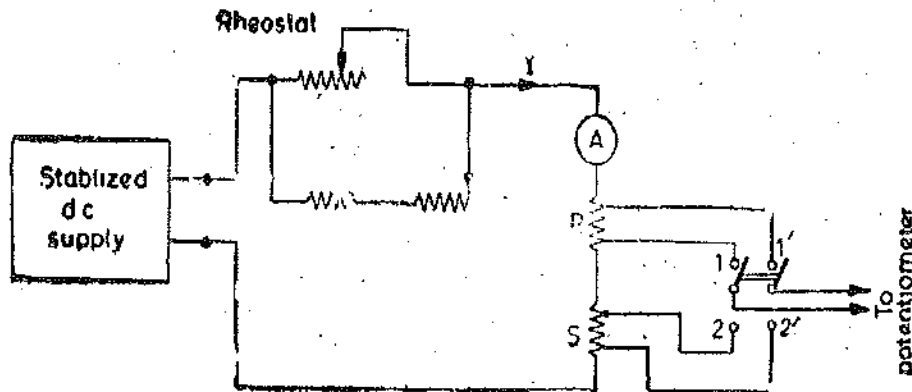

Fig. 14.14. Measurement of resistance with potentiometer.

The current through the circuit is controlled with the help of a rheostat. A two pole double throw switch is used. This switch, when put in position 1, 1' connects the unknown resistance to the potentiometer. Suppose the reading of the potentiometer is V_R .

$$V_R = IR \quad \dots(i)$$

Now the switch is thrown to position 2, 2', this connects the standard resistor to the potentiometer. Suppose the reading of potentiometer is V_S .

$$V_S = IS \quad \dots(ii)$$

$$\text{From (i) and (ii)} \quad R = \frac{V_R}{V_S} \cdot S$$

Since the value of standard resistance S is accurately known value of R can also be accurately known.

The accuracy of this method depends upon the assumption that there is no change in the value of current when the two different measurements are taken. Therefore a stable d.c. supply is absolutely necessary. The difficulty of ensuring this condition is the chief disadvantage of this method.

The resistance of the standard resistor, S , which must be accurately known, should be of the same order as the resistance, R , under measurement. The ammeter inserted in the circuit is merely for indicating whether the current flowing through the circuit is within the capacity of the resistors or not otherwise the exact value of current flowing need not be known. It is desirable that the current flowing through the circuit be so adjusted that the value of voltage drop across each resistor is of the order of 1 volt.

The potentiometer method of measurement of resistance is suitable for measurement of low resistances.

4. Measurement of Power. The circuit for measurement of power with a potentiometer is shown in Fig. 14.15. Two measurements are made, one across the standard resistance, S , connected in series with the load and the other across the output terminals of the volt-ratio box.

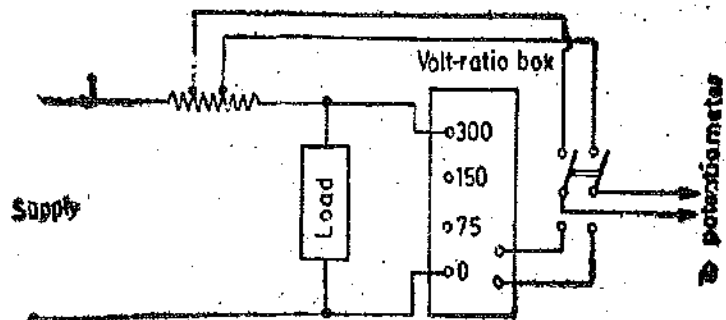

Fig. 14.15. Measurement of power with potentiometer.

The current in the circuit can be computed from the voltage drop across the standard resistance and the voltage across the load can be computed from the potentiometer reading across the output terminals of volt-ratio box,

Let V_R = reading of potentiometer when connected across S ,
 V_B = reading of potentiometer when connected across volt ratio box.

\therefore Current through the load $I = \frac{V_B}{S}$.

Voltage across the load $V = KV_R$, where K = multiplying factor of volt-ratio box.

\therefore Power consumed $= VI = KV_R \frac{V_B}{S}$.

5. Calibration of Wattmeter. For the calibration of a wattmeter, a circuit similar to Fig. 14'15 may be used. Such an arrangement, however, results in a considerable consumption of power especially when the wattmeter has a large rating. In order to save expenditure of power, the arrangement of Fig. 14'16 is used. The current coil of wattmeter is supplied from a low voltage supply and a series rheostat is inserted to adjust the value of current.

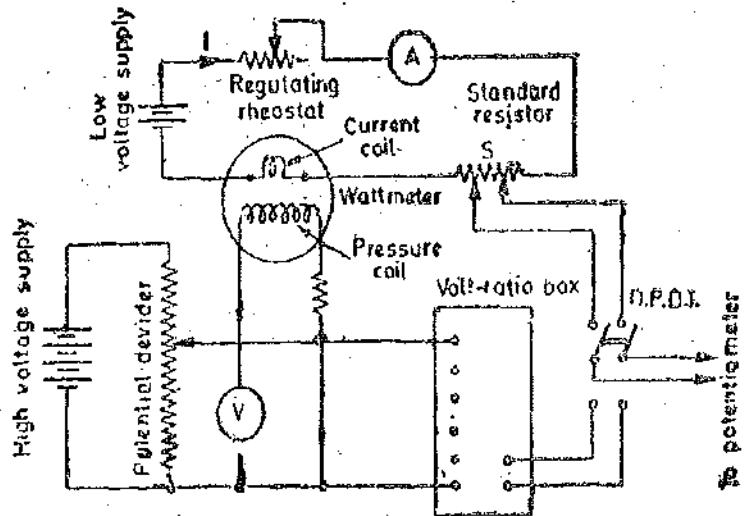

Fig. 14'16. Calibration of wattmeter with a d.c. potentiometer.

The potential circuit is supplied from the supply: A volt-ratio box is used to step down the voltage for the potentiometer to read. As explained earlier on page 394, this type of arrangement is known as "Phantom Loading". The voltage, V , and the current, I , are measured in turn with the potentiometer employing a double pole double throw (D.P.D.T.) switch. The true power is then VI and the wattmeter reading may be compared with this value.

Example 14'5. During the measurement of a low resistance using a potentiometer the following readings were obtained :

voltage drop across the low resistance under test = 0'4221 V,

voltage drop across a 0'1 Ω standard resistance = 1'0235 V.

Calculate the value of unknown resistance, current and the power lost in it.

Solution. Resistance of unknown resistor $R = \frac{V_R}{V_B} \cdot S = \frac{0'4221}{1'0235} \times 0'1 = 0'041218 \Omega$.

Current through the resistor = $\frac{V_B}{S} = \frac{1'0235}{0'1} = 10'235 \text{ A}$.

Power loss in unknown resistance = $I^2 R = (10'235)^2 \times 0'041218 = 4'13 \text{ W}$.

Example 14'6. In the measurement of low resistance by means of a potentiometer, the following readings were obtained :

voltage drop across low resistance under test = 0'83942 V,

voltage drop across a 0'1 Ω standard resistance connected in series with the unknown resistance = 1'01575 V,

The resistance of standard resistor at the temperature of test is 1.00014Ω . Upon setting the potentiometer dials to zero and breaking the current passing through the unknown resistance, the thermal emf of latter produced a galvanometer deflection equivalent to $23 \mu\text{V}$, the direction of the deflection being the same as that produced by an increase of the potentiometer reading during the voltage measurement. Calculate the resistance of the unknown.

Solution. Indicated voltage drop across the unknown resistance = 0.83942 V .

Thermal emf with unknown resistance = $23 \mu\text{V} = 0.000023 \text{ V}$.

\therefore Actual voltage drop across unknown resistance $V_R = 0.839420 - 0.000023 = 0.839397 \text{ V}$.

\therefore Unknown resistance $R = \frac{V_R}{S} \times S = \frac{0.839397}{1.01575} \times 0.10014 = 0.08273 \Omega$.

Example 14.7. A potentiometer that is accurate to $\pm 0.0001 \text{ V}$ (Standard Deviation) is used to measure current through a standard resistance of $0.1 \pm 0.1\%$ (Standard Deviation). The voltage across the resistance is measured to be 0.2514 V . What is the current and to what accuracy it has been determined?

Solution. Current $I = \frac{V}{S} = \frac{0.2514}{0.1} = 2.514 \text{ A}$.

Since $I = \frac{V}{S}$,

the fractional standard deviation of current is

$$\frac{\delta I}{I} = \sqrt{\left(\frac{\delta V}{V}\right)^2 + \left(\frac{\delta S}{S}\right)^2} = \sqrt{\left(\frac{0.0001}{0.2514}\right)^2 + (0.001)^2} = 0.00112$$

Percentage accuracy of measurement of current = $\pm 0.00112 \times 100 = \pm 0.112\%$.

14.13. Protection of Standard Cell and Galvanometer. When the potentiometer is not balanced, the galvanometer circuit carries current. This current may be excessively high if the working point is far away from balance conditions. Another delicate component in the potentiometer set up is the standard cell, in which the current must be limited to 0.1 mA otherwise it will be damaged. The usual practice to protect a galvanometer against overcurrents is to shunt it with a low resistance. But if this practice is followed in a potentiometer, it will not only fail to protect the standard cell but on the other hand increase the current in the standard cell during the standardizing process. This is because the resistance of the circuit decreases considerably on account of a low resistance put in parallel with the galvanometer.

Therefore a series resistance is used to limit the current in both the standard cell and the galvanometer. This resistance should be sufficiently large to protect the circuit if the polarity of standard cell should accidentally be reversed. The current in the galvanometer circuit is to be limited to 0.1 mA and assuming a voltage of 1.02 V for the standard cell, the total series resistance of the circuit should be

$$R = \frac{1.02 + 1.02}{0.1 \times 10^{-3}} = 20,400 \Omega.$$

Thus a series resistance of at least $20,000 \Omega$ be inserted in the standard cell circuit in order to protect it against overcurrents.

14.14. Self-Balancing Potentiometers. The self-balancing potentiometer is widely used in industry because its action is automatic and thus eliminates the constant attention of an operator. In addition to its automatic self-balancing features, it also draws a curve of the quantity being measured with the help of recording mechanism. Besides it can be mounted on a switchboard or panel and thus acts as a monitoring device for the quantity under measurements. Hence a self-balancing potentiometer is very useful for instrumentation purposes.

Operation and Components. The emf being measured is balanced against a known emf. In a normal potentiometer any unbalance emf would produce a deflection through the galvanometer. But in a self balancing potentiometer, this unbalance emf is applied to the input of an amplifier which amplifies the signal. This amplified output emf is made to drive a motor that moves a sliding contact which balances the potentiometer.

However, there are some inherent disadvantages in the above set-up. The unbalance emf is d.c. and this is fed to a d.c. amplifier. Now d.c. amplifiers are not stable and therefore their output is subject to a drift, and hence working of the system with a d.c. amplifier is not satisfactory.

To overcome the above difficulty, a convertor is placed between the potentiometer and the amplifier. The convertor consists of a vibrating reed which is excited with alternating current. The reed operates a double throw switch reverses the flow of current through the primary winding of a transformer for each vibration cycle of the reed. Since the current through the primary winding reverses, an alternating voltage is induced in the secondary winding of the transformer. The secondary winding of the transformer is connected to an a.c. amplifier. Thus the unbalance d.c. emf from potentiometer is converted to a.c. and is amplified. This amplified a.c. output is proportional to the unbalance d.c. emf input to the convertor.

The amplifier output is impressed on the control winding of a two phase induction motor. The second winding of the motor is supplied by the line voltage (a.c.). The a.c. line voltage is shifted 90° in phase with respect to the voltage supplied by the converter. This phase shift is achieved by having a capacitor in the converter driving circuit. The output of amplifier on one phase (i.e. the control winding) of the two phase motor will either lead or lag, by 90° , the a.c. line voltage applied to the other phase of the motor. The direction of rotation of the motor depends upon the phase of the amplifier output voltage which, in turn depends upon the polarity of the unbalance d.c. emf fed to the converter. Thus if the emf being measured is greater than the balancing voltage of the potentiometer the motor will rotate in one direction. If the emf being measured is smaller than the balancing voltage, the polarity of unbalance voltage is reversed and thus the output voltage of the amplifier is shifted by 180° and the motor revolves in the opposite direction.

The shaft of the motor is connected mechanically to the slide wire in such a way, that the rotation of the motor decreases the unbalance in the potentiometer circuit. When the emf being measured is equal to the potentiometer voltage, the amplifier output voltage is zero and the motor thus stops rotating. Therefore under any condition of unbalance, the amplifier output voltage will cause the motor to move and cause the sliding contact to come to balance conditions.

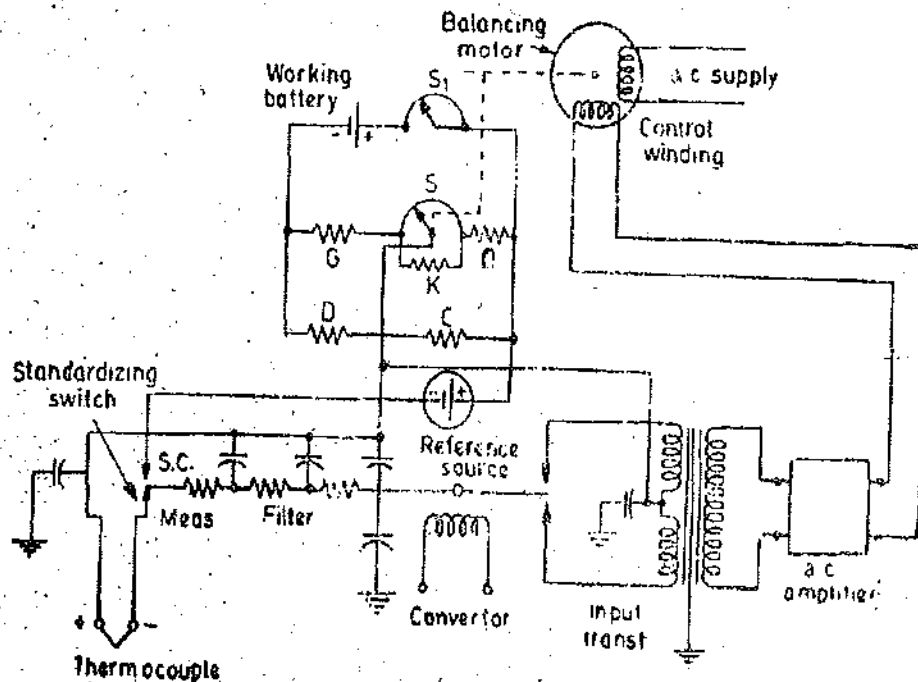

Fig. 14-17. Self-balancing potentiometer.

The circuit diagram of a Leeds Northrup speed O-Max self-balancing potentiometer is shown in Fig. 14'17. This circuit is used to record the temperature of thermocouples. The emf produced by a thermocouple is a function of the temperature difference between its hot and cold junctions. The variation in temperature of the reference junction is compensated by an electrical compensating circuit. The drop across resistor D , which is made of nickel copper alloy, compensates for the change in temperature of reference junction. Resistor G balances the voltage drop across D at the desired base temperature. Zero suppression may also be included in resistor G . Resistance K and slide wire S form the actual measuring circuit and resistor B produces correct voltage drop for the calibration of the circuit with the reference voltage. The reference voltage is provided by a Zener source. The working current can be adjusted by a rheostat S_1 .

The signal supplied to the potentiometer is filtered with a low pass filter. The filter capacitors across the input circuit have no effect upon the d.c. emf supplied to the potentiometer but variations in the input signal and any stray a.c. signals that may be impressed upon the input signal are smoothed out by the filter.

The motor, which moves the slide wire contact to maintain potentiometer balance, is mechanically coupled to a pen mechanism. The pen, actuated by the mechanism, moves over a chart which is driven by a separate clock motor. Thus the temperature is recorded on the strip chart.

We have already mentioned some of the applications of self-balancing potentiometers. There are many more applications. They are even used in multiplying and dividing networks in analogue computers and in special function generators.

A.C. POTENTIOMETERS

14'15. Introduction. The d.c. potentiometer is an accurate and versatile instrument and thus it is obvious that the potentiometer principle be applied to measurement of alternating currents and voltages. The principle of alternating current potentiometer is the same as that of the direct current potentiometer. The most important difference between a d.c. and an a.c. potentiometer is that, whereas in a d.c. potentiometer only the magnitudes of the unknown emf and potentiometer voltage drop have to be made equal to obtain balance, in the a.c. instrument both magnitudes and phases of the two have to be same to obtain balance. Thus an ordinary d.c. potentiometer cannot be used for a.c. measurements and certain modifications have to be made and additional features incorporated in it so that it may be used for a.c. work.

The a.c. potentiometer is a complicated instrument and there are certain important factors which must be considered for its operation. They are :

1. A necessary requirement for balance in an a.c. potentiometer is the equality of voltages being compared at all instants. This requires equal phase and magnitude at all instants. Thus in other words it means that the frequency and waveform of the current in the potentiometer circuit must exactly be the same as that of the voltage being measured. Thus in all a.c. potentiometers the potentiometer circuit must be supplied from the same source as the voltage or current being measured.

2. A vibration galvanometer, which is a tuned device, is usually used as a detector in a.c. potentiometers. The presence of harmonics in one or both of the voltages being compared, the balance point may not be the same if a tuned detector (responding to only one frequency) is used. As an alternative arrangement, if an average indicating detector is used, it may not show the same balance point as an rms indicating device. In the presence of harmonics, it may be possible that a balance can never be achieved, the detector showing only a minimum balance. In such a situation, the accuracy of measurements is seriously affected. Therefore, the source of a.c. supply is made as sinusoidal as possible.

3. The ratio of two voltages (*i.e.*, the unknown voltage and the voltage across the potentiometer) may be determined with a high degree of precision, the accuracy with which the value in volt can be stated is determined by the accuracy with which the reference voltage (*i.e.* voltage across the potentiometer) is known or the accuracy with which a reference (working) current can be known. There being no a.c. reference source (the reference source in d.c. being a standard cell or a Zener source), the absolute accuracy with which an a.c. voltage can be measured in an a.c. potentiometer cannot be comparable with corresponding type of d.c. measurement.

4. Extraneous or stray emfs picked up from stray fields or couplings between portions of the potentiometer circuit seriously effect the result. These emfs must be eliminated, compensated for or measured since they may add vectorially to the emf being measured.

14'16. **Standardizing of A.C. Potentiometers and use of Transfer Instruments.** The a.c. potentiometers are made direct reading type, *i.e.*, the readings are read off directly from the dial settings. In order to do that the a.c. potentiometer must be standardized as is done in the case of d.c. instruments. The standardization is done with the help of a standard d.c. source, *i.e.*, a standard cell or a Zener source and a transfer instrument. This transfer instrument is usually an electro-dynamo-meter milli-ammeter, so constructed that its response to alternating currents is the same as its d.c. response. Such an instrument can be calibrated on d.c. and then brought to the same setting on a.c. Alternatively a thermocouple type of instrument may be used as a transfer instrument.

14'17. **Types of A.C. Potentiometers.** A.C. potentiometers may be classified according to the manner in which the value of unknown voltage may be measured by the instrument dials and scales. The a.c. potentiometers may be broadly classified as :

1. **Polar Type.** In these instruments, the magnitude of the unknown voltage is read from one scale and its phase angle, with respect to some reference phasor, is read directly from a second scale. Provision is made to read phase angles up to 360°. The voltage is read in the form $V \angle \theta$ (See Fig. 14'18).

2. **Co-ordinate Type.** These instruments are provided with two scales to read respectively the inphase component ' V_1 ' and the quadrature component ' V_2 ' of the unknown voltage V . These components are 90° out of phase with each other.

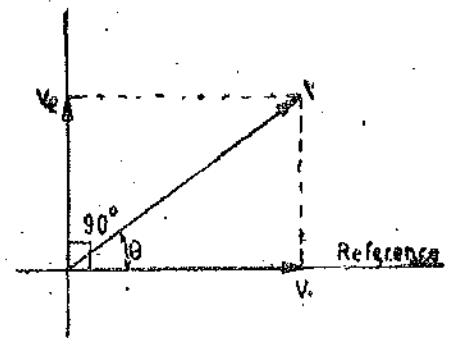

Fig. 14'18

Then voltage $V = \sqrt{V_1^2 + V_2^2}$ and its phase angle with respect to current in the 'inphase' portion of the potentiometer is $\theta = \tan^{-1} (V_2/V_1)$. Provision is made in these potentiometers to read both positive and negative values of V_1 and V_2 so that all angles up to 360° are covered.

14'18. **Drysdale Polar Potentiometer.** This instrument consists of a potentiometer of ordinary d.c. type, except that the resistance coils are non-inductively wound and the following auxiliary apparatus is used :

1. **Drysdale Phase Shifting Transformer.** The phase shifting transformer consists of a laminated silicon steel stator which houses a two or a three phase winding. The rotor is also a laminated structure having slots in which a winding is provided. There is a small air gap between the rotor and the stator. When current flows in the stator winding, a rotating field is produced, thereby inducing an emf in the rotor winding. The rotor can be adjusted at will through any required angle, the phase displacement of rotor emf being equal to the angle through which the rotor has been moved from its zero position. A scale and pointer are provided on top of the instrument to indicate the angle through which rotor has been moved from its zero position. The scale is graduated both in degrees and cosines of the angles.

A phase shifter operated from a single phase supply may also be used by means of a phase

splitting device. This device is shown in Fig. 14'19. In this phase shifter it is only necessary to have two separate windings displaced by 90° in space on the stator. One winding is fed directly from the supply while the other winding is connected in series with a resistance R and a variable capacitor C . The values resistance of R and capacitance C are adjusted until the currents through the two windings are equal and are 90° displaced from each creating a uniform revolving field. The quadrature adjustment is explained in Art. 14'18.

For a particular position of the rotor the induced emf due to each of the stator winding is proportional to the cosine of the angular displacement from position of maximum emf. The emf induced in rotor winding due to stator winding 1,

$$e_1 = KI \sin \omega t \cos \theta$$

and that due to stator winding 2 is

$$e_2 = KI \sin (\omega t + 90^\circ) \cos (\theta + 90^\circ) = -KI \cos \omega t \sin \theta$$

\therefore The resultant emf in the rotor $e = KI [\sin \omega t \cos \theta - \cos \omega t \sin \theta] = KI \sin (\omega t - \theta)$.

The above relationship shows that the rotor emf has a constant amplitude but the phase angle is given by rotor position θ .

When a three phase supply is available, it is usual to employ a three phase shifting transformer as it is less sensitive to small changes in frequency than the phase splitting circuit using single phase supply.

2. **Transfer Instrument.** A precision type electro-dynamometer ammeter is required for standardization purposes. In order to standardize the a-c potentiometer the slide wire circuit is switched on to a direct-current supply, and the standard current is obtained in the ordinary way, using a standard cell. This standard current, required to make the potentiometer direct reading, is measured by a precision ammeter which is included in the battery supply circuit of the potentiometer. During operation on alternating current, the ammeter is still included in the supply circuit, and the rms value of the slide-wire current is maintained at the same value as was required on direct current. Since the coils of the potentiometer are non-inductively wound, the potentiometer remains direct reading when used with an alternating current supply. A change over switch, to enable the potentiometer to be used on either direct or alternating current, is also included in the auxiliary apparatus.

Operation with Alternating Current. A simplified diagram of connections of the potentiometer for use with alternating currents is given in Fig. 14'20. The Kelvin-Varley slide principle is employed in the slide-wire circuit as shown. *V.G.* is a vibration galvanometer—used as a detector for measurements at commercial frequencies. This must be carefully tuned to give resonance at the frequency of the circuit under test. r is a shunting resistor for the reduction of the range of the potentiometer. When this shunt is put in circuit by the switch S_1 , the resistor R is simultaneously connected in series with the slide wire circuit in order that the resistance of the working portion of the potentiometer may be maintained constant. R' is a rheostat for adjustment of the slide-wire current. A is the precision ammeter as mentioned above. The phase-shifting transformer whose connections are given in Fig 14'19 is omitted for the sake of clearness.

The potentiometer is first standardized by adjusting rheostat R' , and the standard current is

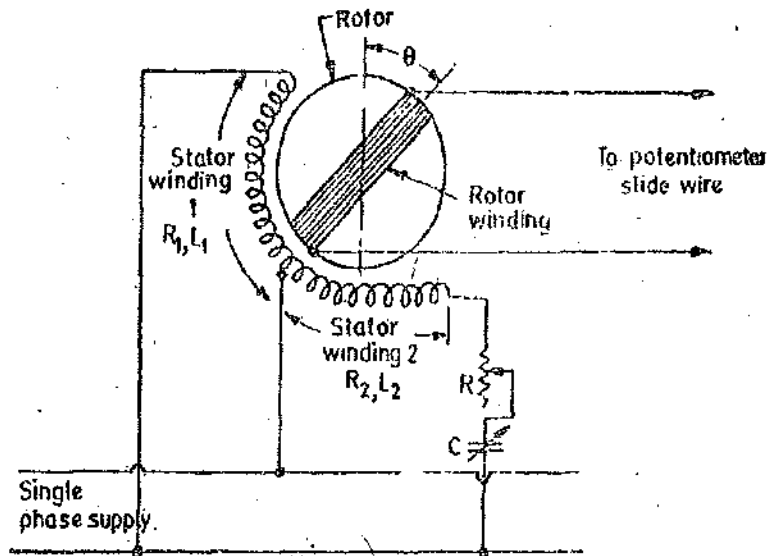

Fig. 14'19. Drysdale phase shifting transformer.

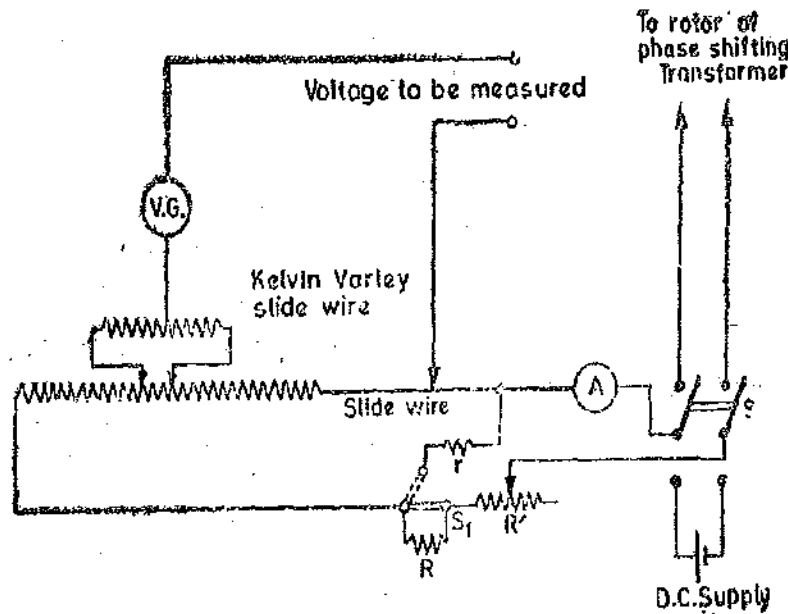

Fig. 14'20. Drysdale (Polar-type) A.C. Potentiometer.

noted, the switch *S* being thrown over to the battery side for this standardization, the vibration galvanometer being replaced by a d'Arsonval galvanometer.

The switch *S* is then thrown over to the alternating supply side, the standard cell and d'Arsonval galvanometer being previously replaced by the alternating voltage to be measured and the vibration galvanometer, respectively. The stator windings of the phase-shifter are then adjusted to exact quadrature by means of the variable resistor and capacitor, these being adjusted until the alternating current in the slide-wire is constant for all positions of the rotor.

Balance of the potentiometer is obtained by successive adjustment of the sliding contacts of the slide-wire circuit and of the rotor of the phase-shifter. The readings of potentiometer dials and the slide-wire, at balance, give the magnitude of the voltage being measured, as in the case of direct-current measurements, while the reading on the scale of the phase-shifter gives the phase of the voltage being measured relative to the supply voltage. If the voltage measured is that across a standard resistance through which the current in the circuit under test is flowing, the magnitude of this current is obtained by dividing the measured value of the voltage by the value of the standard resistance, while its phase relative to the voltage of the circuit is read off from the scale of the phase shifting transformer. For accurate results it is necessary that the voltage and frequency of the supply are steady and that the waveform of the voltage are reasonably sinusoidal.

14'18. Gall-Tinsley (co-ordinate type) A.C. Potentiometer. This potentiometer consists of two separate potentiometer circuits enclosed in a common case. One is called the "in-phase" potentiometer and the other the "quadrature" potentiometer. The slide-wire circuits are supplied with currents which have a phase difference of 90°. On the first of these potentiometers, that component of the "unknown" voltage which is in phase with the current in the slide-wire circuit of the potentiometer is measured. On the other potentiometer the component of the "unknown" voltage in phase quadrature with the current in its slide-wire circuit is measured. Since the two slide-wire currents are in quadrature, the two measured values are the quadrature components of the unknown voltage. If these measured values are V_1 and V_2 respectively, then the unknown voltage is given by $V = \sqrt{V_1^2 + V_2^2}$, and its phase difference from the current in the "in-phase" potentiometer slide-wire circuit is given by the angle θ where $\tan \theta = V_2/V_1$.

Fig. 14'21 shows the connections of the potentiometer, simplified somewhat for the purpose of clearness. The in-phase and quadrature potentiometer circuit are shown, with their sliding contacts *bb'* and *cc'* and rheostats *R* and *R'* for current adjustment. The supplies to the potentiometer are obtained from a single-phase supply by means of the arrangement shown in Fig. 14'22.

T_1 and T_2 are two step-down transformers which supply about 6 V to the potentiometer circuits. They also serve to isolate the potentiometer from the line and are usually provided with earthed screens between the windings. The supply to T_2 is obtained through a variable resistor R and variable capacitor C for the purpose of phase splitting. Quadrature phase displacement is obtained by adjusting C and R .

Referring again to Fig. 14'21, $V.G.$ is a vibration galvanometer (tuned to the supply frequency) and K is its key. A is a reflecting dynamometer instrument for maintaining the current in the two slide-wires at the standard value (50 mA). S_1 and S_2 are two "sign-changing" switches which may be necessary to reverse the direction of the unknown emf applied to the slide-wires. The necessity of these switches depends on the relative phases of the unknown and slide wire-voltages. S_3 is a selector switch by which the unknown voltages to be measured are placed in the circuit. There are four pairs of terminals for the application of such voltages, the connections to only one pair—to which an unknown voltage V is applied—being shown in the figure. The selector switch, when in the position shown in the figure—called the "test position"—allows the current in the quadrature potentiometer slide-wire to be compared with that in the in-phase potentiometer wire, utilizing the mutual inductance M for the purpose.

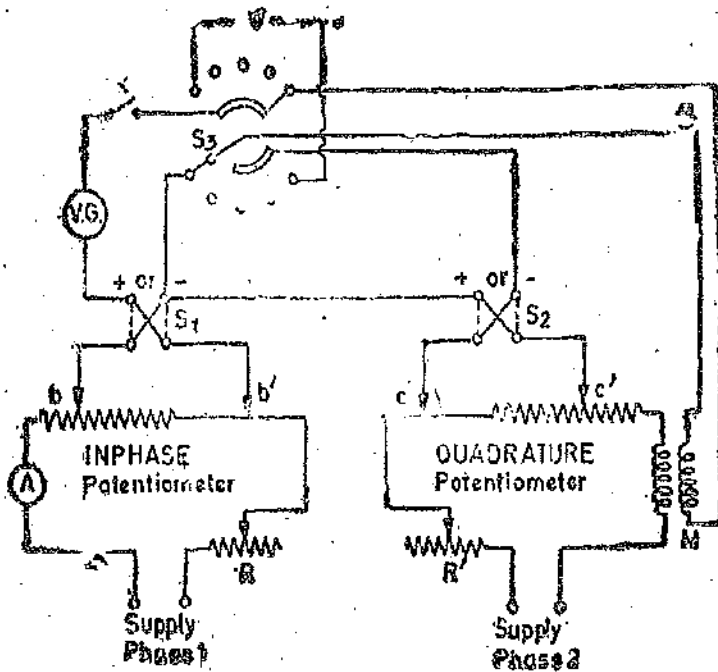

Fig. 14'21 Connections of gall-tinsley a.c. potentiometer.

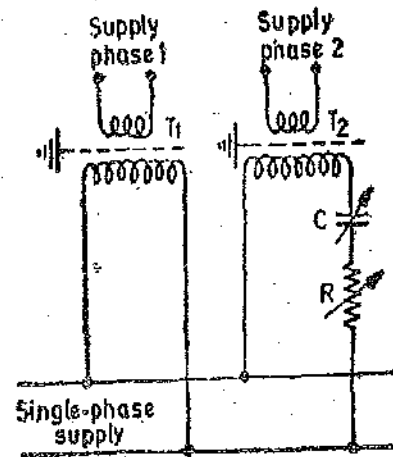

Fig. 14'22. Phase-splitting circuit.

Operation. The current in the in-phase potentiometer wire is first adjusted to its standard value by means of a direct current supply and a standard cell, the vibration galvanometer being replaced by a galvanometer of the d'Arsonval type for this purpose. The dynamometer ammeter is of the torsion head type, and the torsion head is turned to give zero deflection on direct current. This setting is left untouched during the calibration with alternating current, the slide-wire current being adjusted to give zero deflection again. The vibration galvanometer is then placed in circuit and the direct current supply is replaced by the alternating supplies.

Now, the magnitude of the current in the quadrature potentiometer wire must be the same as that in the in-phase potentiometer—namely, the standard value of 50 mA. These two currents must also be exactly in quadrature. Rheostat R is adjusted until the current in the in-phase potentiometer wire is the standard value (as indicated on A). The selector switch S_3 is then switched on to the test position (shown in Fig. 14'21). The emf induced in the secondary winding of the mutual inductor M —assuming M to be free from eddy current effects—will lag 90° in phase behind the current in the primary winding, i.e., in the quadrature potentiometer slide-wire. Also, if i is the primary current, then the emf induced in the secondary is $2\pi \times \text{frequency} \times M \times i$, where M is

the value of the mutual inductance. Therefore, for given values of frequency and mutual inductance, the induced emf when i has the standard value 50 mA, can easily be calculated. Now, if $f=50$ Hz and $M=0.0636$ H, the secondary induce emf $=2\pi \times 50 \times 0.0636 \times 0.050=1.0$ V, when i has the standard value.

The slide-wire of the in-phase potentiometer is thus set to this calculated value of induced emf in the secondary of M (the slide-wire current being maintained at its standard value), and rheostat R and capacitor C (See Fig. 14.22) are adjusted until exact balance is obtained. For balance the current in the quadrature potentiometer slide-wire must be both equal to the standard value and also must be exactly 90° out of phase with the current in the in-phase slide-wire. This latter condition follows from the fact that the emf in the secondary of M lags 90° in-phase behind the primary current, and, therefore, for this emf to be in-phase with the voltage drop across a portion of the in-phase slide-wire, the current in the primary of M must be in exact quadrature with the current in this in-phase slide-wire. Any difference in polarity between the two circuits is corrected for by the sign-changing switches S_1 and S_2 .

These adjustments having been made, the unknown voltage is switched in circuit by means of the selector switch S_3 . In this position of S_3 , the two slide-wire circuits are in series with one another and with the vibration galvanometer. Balance is obtained by adjusting both pairs of sliding contacts (bb' and cc') together with the reversal of switches S_1 and S_2 , if necessary. At balance, the reading of the slide-wire of the in-phase potentiometer, together with the position of S_1 , gives the magnitude and sign of the in-phase component of the unknown voltage, while the reading of the quadrature potentiometer, with the position of S_2 , gives the magnitude and sign of the quadrature component.

For example, if both S_1 and S_2 are in the positive position and V_1 and V_2 are the in-phase and quadrature components respectively of the unknown voltage V , then the phase of V is as shown in Fig. 14.23, while its magnitude is $\sqrt{V_1^2 + V_2^2}$.

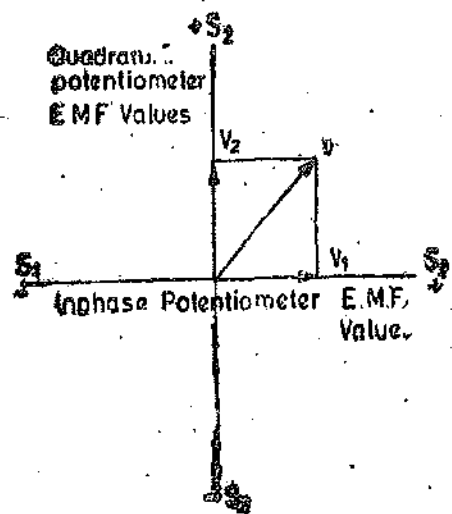

Fig. 14.23

Errors. The errors which may occur in using this potentiometer may be due to :

(a) Slight differences in the reading of the reflecting dynamometer instrument on a.c. as compared with the reading on d.c. Such errors may cause the standard current value on a.c. to be slightly incorrect.

(b) Mutual inductance between the various parts of the circuit. An error in the nominal value of the mutual inductance M would cause the current in the quadrature slide-wire circuit to be somewhat different from the standard value.

(c) Inaccuracy of the method of measuring the frequency, which again would cause an error in the quadrature slide-wire standard current value.

(d) The fact that inter-capacitance, earth capacitance and mutual inductance effects are present in the slide wire coils and affect the potential gradient.

(e) The existence of harmonics in the supply waveform. Standardization of the potentiometer is based upon an rms value of current, while the potential balances on the slide-wires are dependent upon the fundamental only.

14.19. Quadrature Adjustments of Currents. The action of the phase-splitting circuit may be understood by referring to Fig. 14.24, which gives an equivalent circuit for the two potentiometers. R_1 and L_1 are the equivalent resistance and inductance of the in-phase potentiometer circuit, and R_2 and L_2 those of the quadrature potentiometer. When the potentiometer currents are equal and in quadrature, $I_2 = jI_1$

or
$$\frac{V}{R_1 + R_2 + j(\omega L_2 - 1/\omega C)} = j \frac{V}{R_1 + j\omega L_1} \dots(14.1)$$

Therefore, $R_1 + j\omega L_1 = j(R + R_2) - (\omega L_2 - 1/\omega C)$

By separating real and imaginary parts, we obtain the conditions for phase splitting as :

$$R_1 + \omega L_2 = 1/\omega C \quad \dots (14'2)$$

and $\omega L_1 - R_2 = R \quad \dots (14'3)$

The phase splitting is adjusted by means of R and C .

This phase-splitting circuit has been used in later forms of the a.c. potentiometer in place of the original quadrature device described by D.C. Gall, which used a transformer and variable resistor.

14'20. Campbell-Larsen Potentiometer. In this instrument the two rectangular components of the voltage under test are measured in terms of the voltage drops across a slide-wire resistor (for the in-phase component) and the voltage induced in the secondary of a mutual inductor (for the quadrature component). In the original Larsen potentiometer the slide-wire and primary circuit of the mutual inductor were in series and carried the same current, but difficulties in construction of the latter and in the operation of the potentiometer at different frequencies led to Campbell's modification of the instrument.

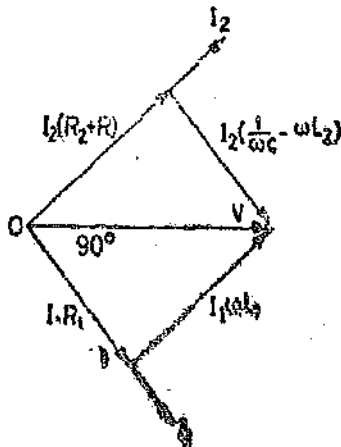
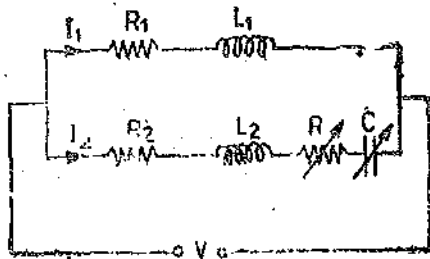

Fig. 14'24. Phase-splitting circuit.

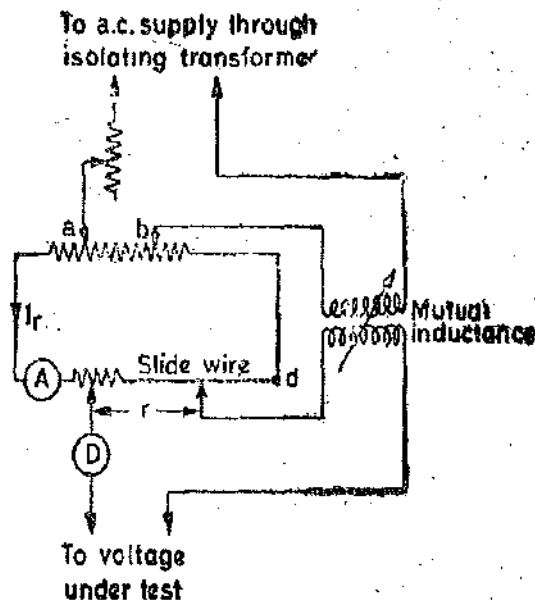

Fig. 14'25. Campbell Larsen potentiometer.

A simplified circuit, as modified, is shown in Fig. 14'25. D is an a.c. detector—either a vibration galvanometer or telephones, depending upon the frequency. While current I passes through the primary of the mutual inductor M , only a portion of this current, namely I_r , passes through the slide-wire circuit. If the resistance between the movable contacts ab is S and round the path adb is R , then $I_r = IS/(R+S)$. The setting of S , by means of a dial resistance, is arranged to be proportional to the frequency at which the test is being carried out, the dial being calibrated directly in terms of frequency. Since $R+S$ is constant in magnitude, $I_r \propto S \propto$ frequency, so that both the voltage drop in the slide-wire $I_r r$ and the voltage in the secondary of the mutual inductor are proportional to frequency. S and M are chosen so that the settings of r and M give the two components of the voltage being measured directly in volt.

A special thermal device is used for the a.c. standardization. The preliminary d.c. standardization utilizes a standard cell, and the reference current, indicated on A , is thus obtained

The a.c. supply to the potentiometer and the voltage under test must be obtained from the same source, but the instrument is isolated through a transformer.

14.21. Applications of A.C. Potentiometers. Such applications are numerous, as the a.c. potentiometer and only a limited number of applications can be given in the space available here.

1. Voltmeter Calibration. Low voltages—up to 15 V or thereabouts—can be measured directly. Higher voltages can be measured by using a volt-box (for medium voltages) or two capacitors in series (for high voltages) in conjunction with the potentiometers.

2. Ammeter Calibration. The measurement of various alternating currents required for such calibration may be made by the use of non-inductive standard resistors with the potentiometer, the method being similar to that adopted when the calibration is to be carried out with direct current.

3. Wattmeter and Energy-meter Testing. The testing circuit for wattmeters and energy meters is the same as that used in the case of d.c. measurements (See Fig. 14.16). A phase shifting transformer is included in the potential circuit to vary the phase of voltage with respect to current so that the energy meter is tested at various power factors.

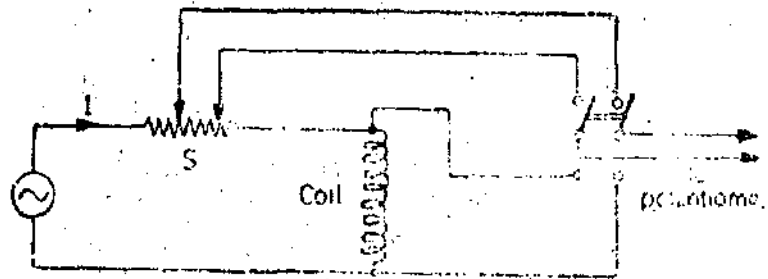

Fig. 14.26. Measurement of self reactance of a coil.

4. Measurement of Self Reactance of a Coil. A standard resistance S is connected in series with the coil whose reactance is to be measured (Fig. 14.26).

Two voltage measurements are done, one across the standard resistance and the other across the coil. Supposing we are using a polar type of potentiometer and the readings are :

voltage across standard resistor $S = V_s \angle \theta_s$

voltage across the coil $= V_c \angle \theta_c$

\therefore Current through coil $I = \frac{V_s}{S} \angle \theta_s$

Impedance of coil $Z = \frac{V_c}{I} = \frac{S V_c \angle \theta_c}{V_s \angle \theta_s} = \frac{S V_c}{V_s} \angle (\theta_c - \theta_s)$

\therefore Resistance of coil $R = Z \cos (\theta_c - \theta_s) = \frac{S V_c}{V_s} \cos (\theta_c - \theta_s)$

Reactance of coil $X = Z \sin (\theta_c - \theta_s) = \frac{S V_c}{V_s} \sin (\theta_c - \theta_s)$

5. Other Applications. The practical field of usefulness of a.c. potentiometers is in engineering measurements in which an accuracy of 0.5 to 1 % is adequate, and in cases where the potentiometer method may be more convenient and simpler than other types of voltage determination. The potentiometer method is indispensable when one is concerned with accurate measurements of ratio of two voltages but when one does not need to know accurately the precise magnitude of either of them. Another type of measurement in which a.c. potentiometers are used is that in which a voltage must be resolved into its two components. The a.c. potentiometer gives excellent results in magnetic testing (See chapter 18) and precise testing of instrument transformers.

Example 14.8 Calculate the inductance of a coil from the following measurements on an a.c. potentiometer.

Voltage drop across a 0.1 Ω standard resistor connected in series with the coil—0.613/12° 6' V

Voltage across the test coil through a 100/1 volt-ratio box = $0.781/50^\circ 48'$ V.

Frequency is 50 Hz.

Solution. Current through the coil $I = \frac{0.613/12^\circ 6'}{0.1} = 6.13/12^\circ 6'$ A.

Voltage drop across the coil $V = 100 \times 0.781/50^\circ 48' = 78.1/50^\circ 48'$ V.

\therefore Impedance of coil $Z = \frac{V}{I} = \frac{78.1/50^\circ 48'}{6.13/12^\circ 6'} = 12.74/38^\circ 42' \Omega$.

Resistance of coil $R = 12.74 \cos 38^\circ 42' = 9.94 \Omega$.

Reactance of coil $X = 12.74 \sin 38^\circ 42' = 7.95 \Omega$.

Inductance of coil $L = \frac{X}{2\pi f} = \frac{7.95}{2\pi \times 50} \text{ H} = 25.3 \text{ mH}$.

Example 14.9. A co-ordinate type potentiometer is used for determination of impedance of a coil and the results obtained are :

Voltage across a 1.0Ω resistor in series with the coil : $+0.238$ V on in-phase dial and -0.085 V on quadrature dial.

Voltage across a 10 : 1 potential divider used with the coil : $+0.3375$ V on inphase dial and $+0.232$ V on quadrature dial.

Calculate the resistance and reactance of the coil.

Solution. Current through the coil $I = \frac{(+0.238 - j0.085)}{1.0} = 0.238 - j0.085$ A.

Voltage across the coil $V = 10(0.3375 + j0.232) = 3.375 + j2.32$ V.

\therefore Impedance of coil $Z = \frac{V}{I} = \frac{3.375 + j2.32}{0.238 - j0.085} = 9.62 + j13.3 \Omega$.

\therefore Resistance of coil $R = 9.62 \Omega$.

Reactance of coil $X = 13.3 \Omega$.

Example 14.10. In the measurement of power by a polar potentiometer, the following readings were obtained :

Voltage across a 0.2Ω standard resistance in series with the load = $1.46/32^\circ$ V.

Voltage across a 200 : 1 potential divider across the line = $1.37/56^\circ$ V.

Estimate the current, voltage, power and power factor of the load.

Solution. Current through the load $I = \frac{1.46/32^\circ}{0.2} = 7.3/32^\circ$ A.

Magnitude of current $I = 7.3$ A.

Voltage across the load $V = 200(1.37/56^\circ) = 274/56^\circ$ V.

Magnitude of voltage $V = 274$ V.

Phase angle of the load $= 56^\circ - 32^\circ = 24^\circ$.

Power factor of load $= \cos 24^\circ = 0.9135$ (lagging).

Power consumed by load $= VI \cos \phi = 274 \times 7.3 \times 0.9135 = 1820$ W.

Example 14.11. A current of 10 A at frequency of 50 Hz was passed through the primary of a mutual inductor having a negligible phase defect. The voltage of primary and secondary terminals were measured on a co-ordinate potentiometer and are given below ;

With secondary open circuited :

Secondary voltage = $-2.72 + j1.57$ V. Primary voltage = $-0.211 + j0.352$ V.

With secondary short circuited : Primary voltage = $-0.051 + j0.329$ V.

The phase of primary current relative to the potentiometer current was same in both the tests.

Determine the resistances and self-inductances of the two windings. Find also the mutual inductance.

Solution. The voltage equations in the phasor form can be written as

$$E_1 = I_1(R_1 + jX_1) + I_2(jX_m), \quad E_2 = I_2(R_2 + jX_2) + I_1(jX_m).$$

- where E_1 = voltage of primary winding, E_2 = voltage of secondary winding,
 I_1 = current of primary winding, I_2 = current of secondary winding,
 R_1 = resistance of primary winding, R_2 = resistance of secondary winding,
 X_1 = self-reactance of primary winding, X_2 = self-reactance of secondary winding,
 and X_m = mutual reactance.

Under open circuit conditions : $I_2 = 0$ $\therefore E_2 = I_1(jX_m)$.

Let $I_1 = I_p + jI_q$, where I_p and I_q are the phase and quadrature components of I_1 .

Therefore, we can write : $E_2 = (I_p + jI_q)(jX_m) = (-I_q + jI_p)X_m$.

From the data given, we have : $-2.72 + j1.57 = -I_q X_m + jI_p X_m$.

or $I_p X_m = 1.57$ V. and $I_q X_m = 2.72$ V.

or $X_m \sqrt{I_p^2 + I_q^2} = 3.14$ V.

but $\sqrt{I_p^2 + I_q^2} = I = 10$ A. $\therefore X_m = \frac{3.14}{10} = 0.314 \Omega$.

Hence mutual inductance $M = \frac{X_m}{2\pi f} = \frac{0.314}{2\pi \times 50}$ H = 1.0 mH.

From (i) and (ii) : $I_p = \frac{1.57}{0.314} = 5.0$ A and $I_q = \frac{2.72}{0.314} = 8.66$ A.

At open circuit $E_1 = I_1(R_1 + jX_1) = (I_p + jI_q)(R_1 + jX_1)$
 $= (I_p R_1 - I_q X_1) + j(I_p X_1 + I_q R_1)$.

Putting the numerical values, we get : $-0.211 + j0.352 = (5R_1 - 8.66X_1) + j(5X_1 + 8.66R_1)$.

Equating real and the imaginary terms, we have : $5R_1 - 8.66X_1 = -0.211$... (iii)

and $5X_1 + 8.66R_1 = 0.352$ (iv)

Solving (iii) and (iv), we get $R_1 = 0.02 \Omega$, and $X_1 = 0.0359 \Omega$.

\therefore Self-inductance of primary winding : $L_1 = \frac{0.0359}{2\pi \times 50}$ H = 0.114 H.

At short circuit of secondary winding : $E_2 = 0$, $\therefore E_2 = I_2(R_2 + jX_2) + I_1(jX_m) = 0$

or $I_2 = -\frac{jX_m}{R_2 + jX_2} I_1$.

Thus $E_1 = I_1(R_1 + jX_1) + I_2(jX_m) = I_1(R_1 + jX_1) + I_1 \frac{X_m^2}{R_2 + jX_2}$

Now at short circuit : $E_1 = 0.051 + j0.329$

Also $I_1(R_1 + jX_1) = -0.211 + j0.352$

\therefore $-0.051 + j0.329 = -0.211 + j0.352 + \frac{(5 + j8.66) \times (0.314)^2}{R_2 + jX_2}$

$$\text{or } R_2 + jX_2 = \frac{0.494 + j0.856}{0.16 - j0.023} = 2.27 + j5.66 \Omega \quad \therefore X_2 = 5.66 \Omega$$

$$\text{Self-reactance of secondary winding } L_2 = \frac{5.66}{2\pi \times 50} \text{ H} = 18 \text{ mH}$$

$$\text{Resistance of secondary winding } R_2 = 2.27 \Omega$$

UNSOLVED PROBLEMS

1. The emf of a standard cell is measured with a potentiometer which gives a reading of 1.01892 V. When a 1 M Ω resistor is connected across the standard cell terminals, the potentiometer reading drops to 1.01874 V. Calculate the internal resistance of the cell. [Ans. 176.6 Ω]

2. A standard cell of 1.0185 V used with a simple potentiometer balances at 50 cm. Calculate (a) the emf of the cell that balances at 72 cm; (b) the percentage error in voltmeter which balances at 64.5 cm when reading 1.23 V; (c) the percentage error in an ammeter that reads 0.43 A when balanced at 43.2 cm with voltage drop across a 2 Ω resistor in the ammeter circuit. [Ans. (a) 1.467 V; (b) 1.2% high; (c) 2.3% low]

3. A slide wire potentiometer is used to measure the voltage between two points of a certain d.c. circuit. The potentiometer reading is 1.0 volt. Across the same two points when a 10,000 Ω/V voltmeter is connected, the indicated reading on the voltmeter is 0.5 V on its 5 V range.

Calculate the input resistance between two points. [Ans. 50,000 Ω]

4. A slide wire potentiometer has a battery of 4 V and negligible internal resistance. The resistance of slide wire is 100 Ω and its length 200 cm. A standard cell of 1.018 V is used for standardizing the potentiometer and the rheostat is adjusted so that balance is obtained when the sliding contact is at 101.8 cm.

(a) Find the working current of the slide wire and the rheostat setting.

(b) If the slide wire has divisions marked in mm and each division can be interpolated to one fifth, calculate the resolution of the instrument. [Ans. 20 mA; 100 Ω ; 0.2 mV]

5. In the circuit of Fig. 14.8, the working voltage of battery is 3.03 V. The current in the working circuit is 2 mA. Determine (a) the resistance of main dial in the measuring circuit, (b) the resistance of the slide wire in the measuring circuit, (c) the resistance R , and (d) the resistance of slide wire in the calibrating circuit. [Ans. 750 Ω ; 10 Ω ; 508 Ω ; 2 Ω]

6. Design a volt-ratio box with a resistance of 20 Ω/V and ranges 3 V, 10 V, 30 V, 100 V. The volt ratio box is to be used with a potentiometer having a measuring range of 1.6 V.

Hint: The output of the volt ratio box should be designed for a voltage of 1.5 V.

[Ans. Resistance at output terminals = 30 Ω ; The total resistances at input terminals are: 60 Ω , 200 Ω , 600 Ω , and 2000 Ω]

7. Measurements for the determination of the impedance of a coil are made on a coordinate type of potentiometer. The results are: Voltage across 1 Ω standard resistance in series with the coil +0.952 V on inphase dial and -0.340 V on quadrature dial; Voltage across 10:1 potential divider connected to the terminals of the coil:

+1.35 V on inphase dial and +1.28 V on quadrature dial. Calculate the resistance and reactance of the coil. [Ans. $R=8.82 \Omega$ and $X=15.5 \Omega$]

8. Power is measured with an a.c. potentiometer. The voltage across a 0.1 Ω standard resistance connected in series with the load is $0.35 - j0.10$ V. The voltage across 10:1 potential divider connected to the supply is $0.8 + j0.15$ V. Determine the power consumed by the load and the power factor. [Ans. 795 W; 0.895]

9. The current taken by a small iron core choke coil is measured by a co-ordinate type a.c. potentiometer. A 1.0 Ω resistance is connected in series with the choke coil. The voltage measurements across the resistance and the choke coil are made. The data obtained:

$$\text{Voltage across } 1.0 \Omega \text{ resistance} = +0.8 - j0.75 \text{ V.}$$

$$\text{Voltage across coil} = +1.2 + j0.3 \text{ V.}$$

Assuming sinusoidal voltage and current, determine the core loss and the magnetizing current of the coil.

[Ans. 0.735 W; 0.951 A]

10. A resistor of 150 Ω is connected in series with a 1000 turn iron cored coil across a 50 Hz supply. The voltages across the resistor and across the coil measured by an a.c. potentiometer are $0.0587 - j0.0650$ V and $0.8593 + j0.5010$ V respectively. The voltage measured across a 500 turn search coil wound over the core is $-0.4175 - j0.2565$ V. Find the iron loss in the core, the copper loss in the coil and the leakage flux considering the circuit as a transformer. [Ans. 0.155 mW; 0.024 mW; 0.07 μ Wb]

11. A non-reactive resistor of 1000 Ω is connected in series with a coil and a capacitor to a 50 Hz supply. If the voltages across each, measured by an a.c. potentiometer are $+0.6 - j0.24$ V, $+0.6 + j0.4$ V and $-0.1 - j0.4$ V respectively, find the power dissipated and the mean stored energy in each component.

[Ans. 0.418, 0.264, 0.036 mW and 0.061, 0.421 μ J]

Power System Measurements

MEASUREMENT OF EARTH RESISTANCE

15.1. Necessity of Earth Electrode. The provision of an earth electrode for an electrical system is necessitated by the following reasons :

1. All the parts of electrical equipment, like casings of machines, switches and circuit breakers, lead sheathing and armouring of cables, tanks of transformers, etc. which have to be at earth potential, must be connected to an earth electrode. The purpose of this is to protect the various parts of the installation, as well as the persons working, against damage in case the insulation of a system fails at any point. By connecting these parts to an earthed electrode, a continuous low resistance path is available for leakage currents to flow to earth. This current operates the protective devices and thus the faulty circuit is isolated in case a fault occur.

2. The earth electrode ensures that in the event of overvoltage on the system due to lightning discharges or other system faults, those parts of equipment which are normally 'dead' as far as voltages are concerned, do not attain dangerously high potentials.

3. In a three phase circuit the neutral of the system is earthed in order to stabilize the potential of the circuit with respect to earth.

15.2. Necessity of Measurement of Resistance of Earth Electrode. An earth electrode will only be effective so long it has a low resistance to the earth and can carry large currents without deteriorating. Since the amount of current which an earth electrode will carry is difficult to measure, the resistance value of the earth electrode is taken as sufficiently reliable indication of its effectiveness. Thus the resistance of earth electrode should be low to give good protection and it must be measured.

15.3. Factors affecting Earth Resistance. The main factors on which the resistance of any earthing system depends are :

1. Shape and material of earth electrode or electrodes used.
2. Depth in the soil at which the electrodes are buried.
3. Specific resistance of soil surrounding and in the neighbourhood of electrodes. The specific resistance of the soil is not constant but varies from one type of soil to another. The amount of moisture present in the soil affects its specific resistance and hence the resistance of earth electrode is not a constant factor but suffers seasonal variations. This calls for periodic testing to ensure that the earth system remains reasonably effective.

The specific resistance of soils varies between wide limits and is very much dependent upon its moisture content. Approximate figures for specific resistance of soil are $80 \times 10^3 \Omega\text{m}$ for moist clay to $80 \times 10^6 \Omega\text{m}$ for sand of normal moisture content. A decrease of moisture content of 30% is capable of producing an increase of 300 to 400% in specific resistance. Thus it is necessary to make regular checks for earth resistance during the year round.

15.4. Methods of Measuring Earth Resistance

1. Fall of Potential Method. Fig. 15.1 shows the circuit for measurement of earth resistance with fall of potential method. A current is passed through earth electrode E to an auxiliary electrode B (which is usually an iron spike) inserted in earth at a distance away from the earth electrode. A second auxiliary electrode A is inserted in earth between E and B . The potential difference V between E and A is measured for a given current I . The flow of ground currents is shown in Fig. 15.2 (c). The lines of the first electrode current diverge and those of the second electrode current converge. As a result the current density is much greater in the vicinity of the electrodes than at a distance from them. The potential distribution between the electrodes is shown in Fig. 15.2 (b). It is apparent from this curve that the potential rises in the proximity of electrodes E and B and is constant along the middle section. The resistance of earth, therefore, is $R_E = V/I$ or V_{EA}/I . The position of electrodes E and B is fixed and the position of electrode A is changed and resistance measurements are done for various positions of electrode A .

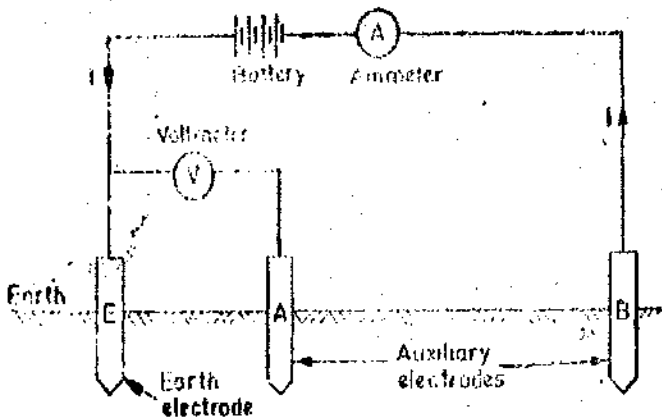

Fig. 15'1. Measurement of earth resistance by fall of potential method.

A graph is plotted between earth resistance against the distance between electrode *E* and *A*. This graph is shown in Fig. 15'3.

From Fig. 15'3, it is clear that the measured value of earth resistance depends upon the position of the auxiliary electrode *A*. The earth resistance rises rapidly initially. When the distance between earth electrode *E* and auxiliary electrode *A* is increased, it then becomes constant, and when the auxiliary electrode *A* approaches the auxiliary electrode *B*, the resistance rises again. The placing

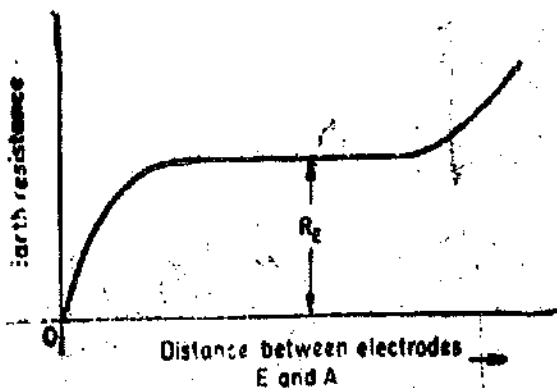

Fig. 15'3. Variation of earth resistance with distance between electrodes *E* and *A*.

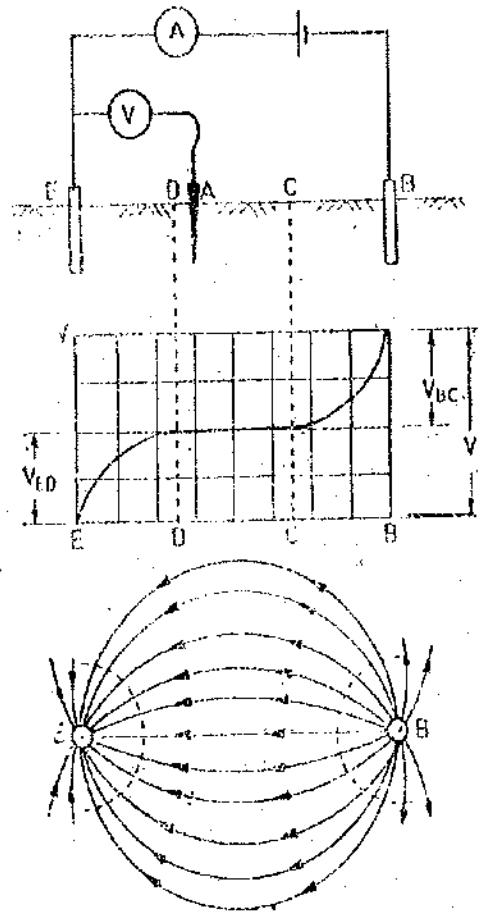

Fig. 15'2. Distribution of potentials between two earthing electrodes.

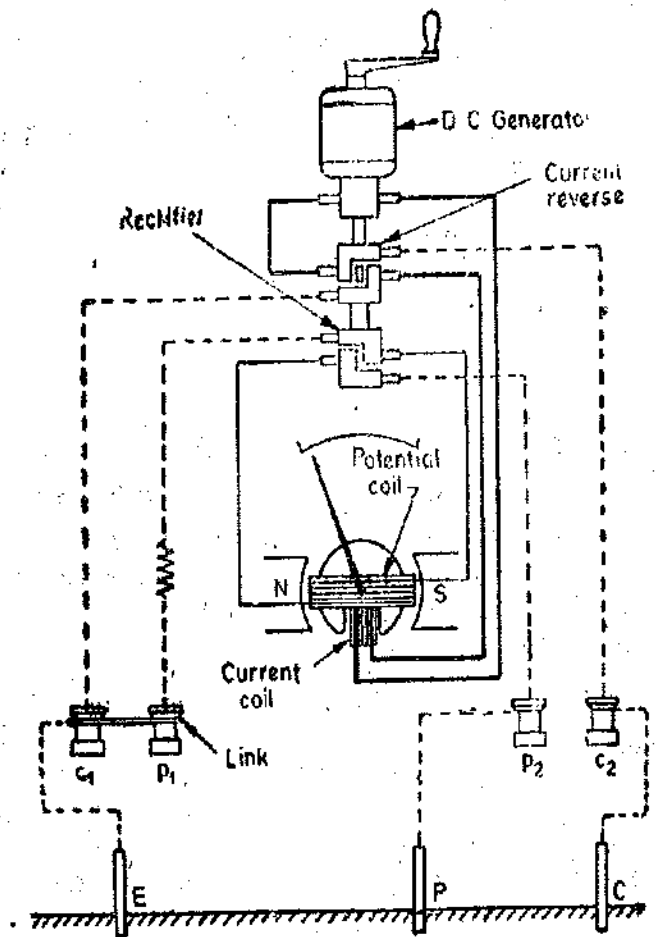

Fig. 15'4. Earth tester.

of electrodes is thus very important and serious error may be caused by incorrect placing of the electrodes. The correct value of resistance of earth, R_E , is when the auxiliary electrode A is at such a distance that the resistance lies on the flat part of curve of Fig. 15'3.

The spacing between the earth electrode E and the auxiliary electrodes A, B should be large so as to get proper results. The distance may be a few hundred metres in case the earth resistance is low.

2. Earth Tester. The resistance of earth can be measured by an earth tester shown in Fig. 15'4. The "Earth Tester" is a special type of Megger (See Art. 8'25 page 218) and it has some additional constructional features and they are :

- (i) a rotating current reverser, and (ii) a rectifier.

Both these additional features consist of simple commutators made up of 'L' shaped segments. They are mounted on the shaft of the hand driven generator. Each commutator has four fixed brushes. One pair of each set of brushes is so positioned that they make contact alternately with one segment and then with the other as the commutator rotates. The second pair of each of set of brushes is positioned on the commutator so that continuous contact is made with one segment whatever the position of the commutator.

The earth tester has four terminals P_1, P_2 and C_1, C_2 . Two terminals P_1 and C_1 are shorted to form a common point to be connected to the earth electrode. The other two terminals P_2 and C_2 are connected to auxiliary electrodes P and C respectively.

The indication of the earth tester depends upon the ratio of the voltage across the pressure coil and the current through the coil. The deflection of its pointer indicates the resistance of earth directly. Although the "Earth Tester", which is a permanent magnet moving coil instrument and can operate on d.c. only, yet by including the reverser and the rectifying device it is possible to make measurements with a.c. flowing in the soil.

The sending of a.c. current through the soil has many advantages and therefore this system is used. The use of a.c. passing through the soil eliminates unwanted effects due to production of a back emf in the soil on account of electrolytic action. Also the instrument is free from effects of alternating or direct currents presents in the soil.

Example 15'1. On a 250 V supply a fault having a resistance of 20Ω develops between the unearthed end of the winding of an electric heater and the frame. If the resistance of the substation earth electrode is 4Ω that of human body 2000Ω , and the safe maximum current through the body is 25 mA, what is the safe maximum resistance of consumer's earth electrode ?

Solution. Fig. 15'5 shows the diagrammatic representation of the problem. Let R be the resistance of earth electrode at the consumer end.

Voltage drop across the human body
 $= 25 \times 10^{-3} \times 2000 = 50 \text{ V.}$

\therefore Voltage between points a and b
 $= 250 - 50 = 200 \text{ V.}$

Current $I = \frac{200}{20+4} = \frac{200}{24} \text{ A.}$

Current through human body

$$= I \frac{R}{R+2000}$$

$$= 25 \times 10^{-3} \text{ A}$$

or $\frac{200}{24} \cdot \frac{R}{R+2000} = 25 \times 10^{-3}$

or $200 R = 0.6 R + 1200$

or Resistance of earth electrode on consumer end $R \approx 6 \Omega$.

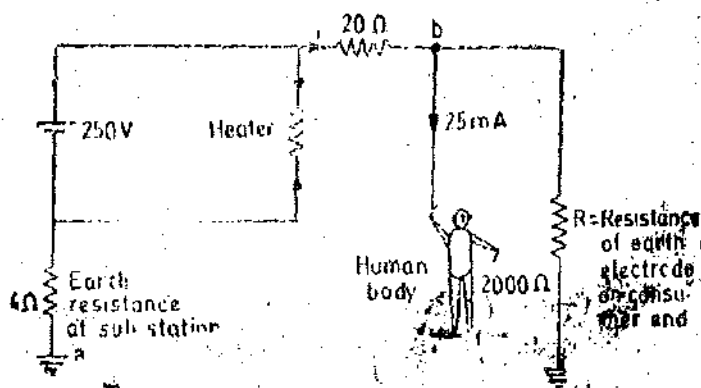

Fig. 15'5

LOCALIZATION OF CABLE FAULTS

15.6. Types of Faults. In this section, faults occurring in cables which are in use on lower distribution voltages will be considered. The common faults which are likely to occur in such cables are :

1. **Ground fault.** The insulation of the cable may breakdown causing a flow of current from the core of the cable to the lead sheath or to the earth. This is called "Ground Fault".
2. **Short circuit fault.** If the insulation between two conductors is faulty, a current flows between them. This is called a "Short Circuit Fault".
3. **Open circuit fault.** An open circuit fault occurs when a conductor gets broken or when a joint pulls out.

15.6. Methods Used for Localizing Faults. The methods used localizing ground and short circuit faults differ from those used for localizing open circuit faults.

15.7. Methods Used for Localizing Ground and Short Circuit Faults. In the case of multi-core cables it is advisable, first of all, to measure insulation resistance of each core to earth and also between cores. This enables us to sort out the core that is earthed in case of ground fault ; and to sort out the cores that are shorted in case of a short circuit fault. Loop tests are used for location of ground and short circuit faults. These tests can only be used if a sound cable runs along with the faulty cable or cables. The loop tests work on the principle of a Wheatstone bridge. The advantage of these tests is that their set up is such that the resistance of fault is connected in the battery circuit and therefore does not effect the result. However, if the fault resistance is high, the sensitivity is adversely affected. In this section only two types of tests viz., Murray, and Varley loop tests are being described.

15.8. Murray Loop Test. The connection for this test are shown in Fig. 15.6. Fig. 15.6 (a) relates to the ground fault and Fig. 15.6 (b) relates to the short circuit fault.

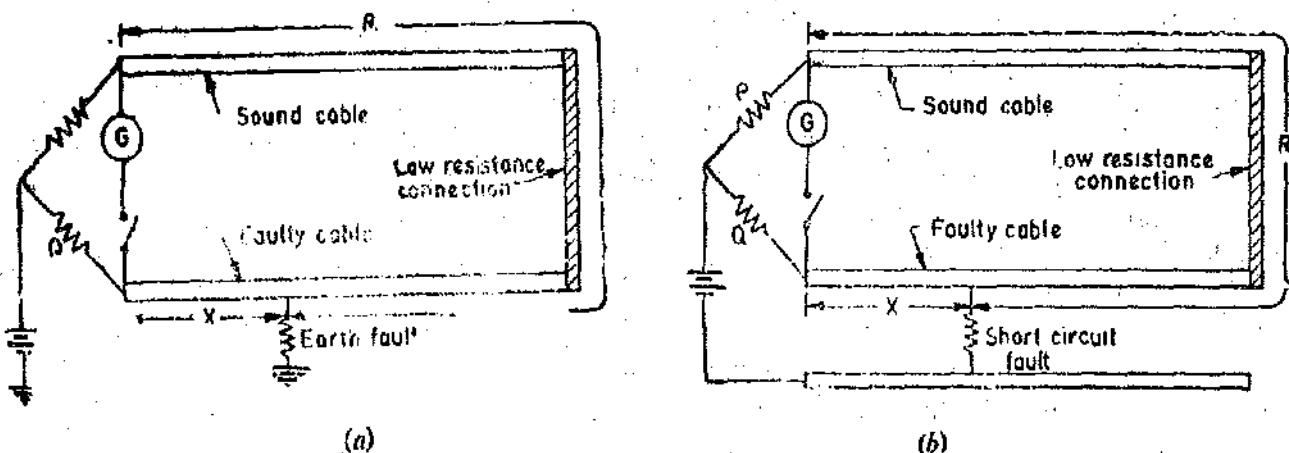

Fig. 15.6. Murray loop test.

In both cases, the loop circuit formed by the cable conductors is essentially a Wheatstone bridge consisting of resistances P , Q , R and X . G is a galvanometer for indication of balance,

The resistors P , Q forming the ratio arms may be decade resistance boxes or slide wires.

$$\text{Under balance conditions : } \frac{X}{R} = \frac{Q}{P} \quad \text{or} \quad \frac{X}{R+X} = \frac{Q}{P+Q}$$

$$\therefore X = \frac{Q}{P+Q} (R+X) \quad \dots(15.1)$$

Here $(R+X)$ is total loop resistance formed by the sound cable and the faulty cable. When the conductors have the same cross-sectional area and the same resistivity, the resistances are proportional

to lengths. If l_1 represents the length of the fault from the test end and l the length of each cable. Then

$$l_1 = \frac{Q}{P+Q} \cdot 2l \quad \dots(15'2)$$

The above relation shows that the position of the fault may be located when the length of the cable is known. Also, the fault resistance does not alter the balance condition because it (resistance) enters the battery circuit. However, if the magnitude of the fault resistance is high, difficulty may be experienced in obtaining the balance condition on account of decrease in sensitivity and hence accurate determination of the position of the fault may not be possible. In such a case, the resistance of the fault may be reduced by applying a high direct or alternating voltage—in consistence with the insulation rating of the cable—on the line so as to carbonize the insulation at the point of the fault.

15'9. Varley Loop Test. In this test we can determine experimentally the total loop resistance instead of calculating it from the known lengths of the cable and its resistance per unit length. The necessary connections for the ground fault are shown in Fig. 15'7 (a) and for the short circuit fault in Fig. 15'7 (b). The treatment of the problem, in both cases, is identical.

A single pole double throw switch K is used in this circuit. Switch K is first thrown to position '1' and the resistance S is varied and balance obtained.

Let the value of S for balance be S_1 . The four arms of the Wheatstone bridge are $P, Q, R+X, S_1$. At balance:

$$\frac{R+X}{S_1} = \frac{P}{Q} \quad \dots(15'3)$$

This determines $R+X$ i.e., the total loop resistance as P, Q and S_1 are known.

The switch K is then thrown to position '2' and the bridge is rebalanced. Let the new value of S for balance be S_2 . The four arms of the bridge now are $P, Q, R, X+S_2$.

At balance, $\frac{R}{X+S_2} = \frac{P}{Q}$

or $\frac{R+X+S_2}{X+S_2} = \frac{P+Q}{Q}$ or $X = \frac{(R+X)Q - S_2P}{P+Q} \quad \dots(15)$

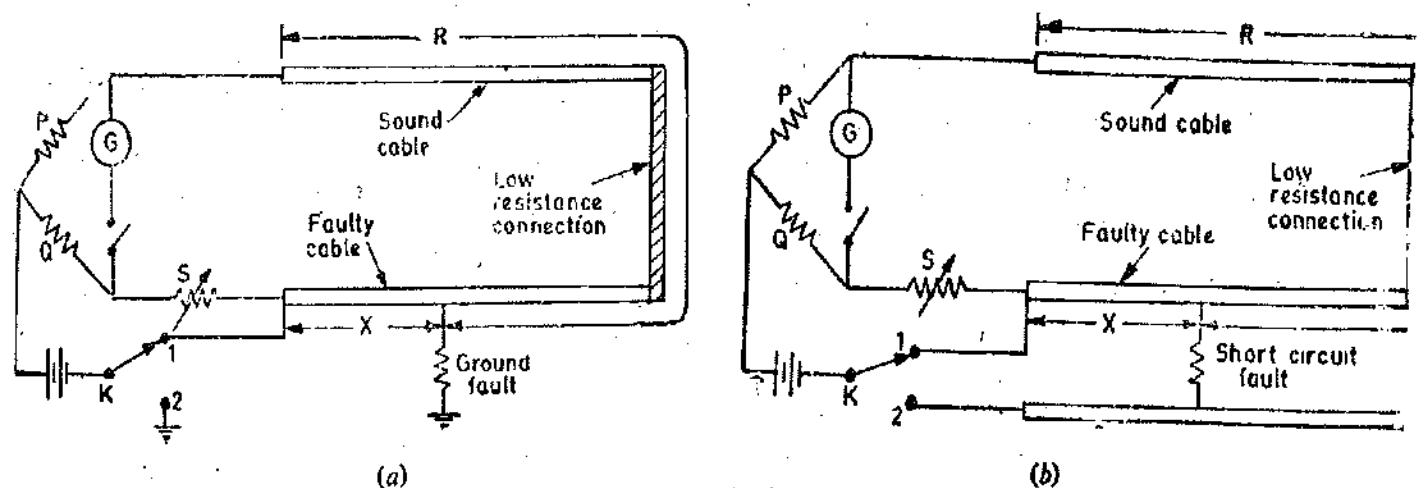

Fig. 15'7. Varley loop test.

Hence X is known from the known values of P, Q, S_2 from this equation and $R+X$ (the total resistance of 2 cables) as determined from Equ. 15'3. Knowing the value of X , the position of the fault is determined. Now:

$$\frac{X}{R+X} = \frac{l_1}{2l} \text{ or } l_1 = \frac{X}{R+X} \cdot 2l \quad \dots(15'5)$$

where l_1 = length of fault from the test end and l = total length of conductor.

Eqns. 15.2 (for Murray loop test) and 15.4 (for Varley loop test) are valid only when the cable sections are uniform throughout the loop. Corrections must be applied in case the cross-sections of faulty and sound cables are different or when the cross-section of the faulty cable is not uniform over its entire length. Since temperature affects the value of resistance, corrections must be applied on this account if the temperatures of the two cables are different. Corrections may also have to be applied in case the cables have a large number of joints.

Example 15.2. In a test for a fault to earth by Murray loop test, the faulty cable has a length of 5.2 km. The faulty cable is looped with a sound cable of the same length and cross-section. The resistances of ratio arms are 100 Ω and 41.2 Ω at balance. Calculate the distance of the fault from the test end.

If the decade resistance boxes forming the ratio arms have limits of error of $\pm 0.5\%$ (standard deviation) of the dial reading, what is the limit of error in the above calculated result?

Solution. Let X be the resistance of cable from the test end to place of fault and $R+X$ be the total resistance of loop. P and Q are the ratio arms.

$$\therefore \frac{X}{R} = \frac{Q}{P}$$

$$\text{or } X = \frac{Q}{P+Q} (X+R) = \frac{41.2}{141.2} (X+R) = 0.292 (X+R).$$

Let l_1 be the distance of fault from test end l be the length of each cable and r resistance per unit length.

$$\therefore X = r l_1 \quad \text{and} \quad X+R = 2rl.$$

$$\therefore \text{Distance of fault from test end : } l_1 = 0.292 \times 2 \times 5.2 = 3.03 \text{ km.}$$

Limiting fractional error of unknown resistance

$$\frac{\delta X}{X} = \sqrt{\left(\frac{\delta P}{P}\right)^2 + \left(\frac{\delta P + \delta Q}{P+Q}\right)^2} = \sqrt{\left(\frac{\pm 0.5}{100}\right)^2 + \left(\frac{\pm 0.5}{100}\right)^2} = 0.707\%$$

$$\text{Therefore limiting error of distance} = 3.03 \times \frac{0.707}{100} \times 1000 = 21.4 \text{ m.}$$

Example 15.3. In a test by Murray loop method for a fault to earth on a 520 metre length of cable having a resistance of 1.1 Ω per 1000 metre, the faulty cable is looped with a sound cable of the same length but having a resistance 2.92 Ω per 1000 metre. The resistances of the other two arms of the testing network, at balance, are in the ratio of 2.7 : 1. Calculate the distance of fault from the testing end of the cable.

Solution. Suppose r_1 and r_2 are the resistances per unit length of faulty and sound cable respectively. Let l be the length of each cable and l_1 be the distance of fault from the test end.

Referring to Fig. 15.6 (a),

$$\frac{X}{R} = \frac{Q}{P} \quad \text{or} \quad X = \frac{Q}{P+Q} (X+R) \quad \dots(i)$$

$$\text{Now} \quad X = r_1 l_1 = \frac{1.1}{1000} l_1$$

$$\text{and} \quad X+R = r_1 l + r_2 l = \left(\frac{1.1}{1000} + \frac{2.92}{1000}\right) \times 520 = 1.76 \Omega.$$

$$\text{Substituting these values in (i), we have : } \frac{1.1}{1000} l_1 = \frac{1}{2.7+1} \times 1.76$$

$$\therefore l_1 = 432 \text{ m.}$$

Example 15.4. A short circuit fault is located by Varley loop test. The circuit of Fig. 15.7 (b) is used for the purpose. The ratio arms are set at $P=5 \Omega$ and $Q=10 \Omega$ and the values of variable resistance S are 16Ω for position 1 of switch K and 7Ω for position 2. The sound and faulty cables are identical and have a resistance of $0.4 \Omega/\text{km}$. Determine the length of each cable and the distance of fault from the test end.

Solution. Let S_1 be the value of resistance S_1 for position 1 and S_2 for position 2.

$$\therefore \frac{R+X}{S_1} = \frac{P}{Q}$$

$$\text{Hence resistance of loop } R+X = \frac{P}{Q} S_1 = \frac{5}{10} \times 16 = 8 \Omega.$$

$$\text{Resistance of each cable} = \frac{8}{2} = 4 \Omega.$$

$$\therefore \text{Length of each cable} = \frac{4}{0.4} = 10 \text{ km.}$$

$$\text{At position 2 we have: } \frac{R}{X+S_2} = \frac{P}{Q}$$

$$\text{or } \frac{R+X+S_2}{X+S_2} = \frac{P+Q}{Q} \text{ or } \frac{8+7}{X+7} = \frac{5+10}{10} \text{ or } X=3.0 \Omega.$$

$$\therefore \text{Distance of fault from testing end} = \frac{3.0}{0.4} = 7.5 \text{ km.}$$

15.10. Location of Open-Circuit Faults in Cables

The location of an open circuit in a cable can be done by a capacitance test. The principle of this method is based upon the fact that the capacitance of a cable length is proportional to its length.

Fig. 15.8 shows a cable which is open circuited at a distance l_1 from end 1. Capacitance measurements are done at end 1 of the cable. Suppose the capacitance value is C_1 . The capacitance measurements are done at end 2 and suppose the measured capacitance is C_2 .

$$\therefore \text{Total capacitance of cable} \\ C = C_1 + C_2.$$

Since capacitance is proportional to the length of the cable, we can write.

$$C = Kl \text{ and } C_1 = Kl_1$$

where K is a constant.

$$\therefore \text{Distance of open circuit fault from end 1 is: } l_1 = \frac{C_1}{C} l = \frac{C_1}{C_1 + C_2} l. \quad \dots(15.6)$$

In case the total capacitance of the cable is known, only one capacitance measurement (i.e. from end 1 of cable) is necessary. The capacitance measurements may be done by any of the known methods like using a De Sauty's bridge or using a ballistic galvanometer.

Fig. 15.8 shows the measurement of capacitance, C_1 , of cable length on end 1, with the help of a capacitance bridge. A frequency generator is used as a source of supply. The cable capacitance

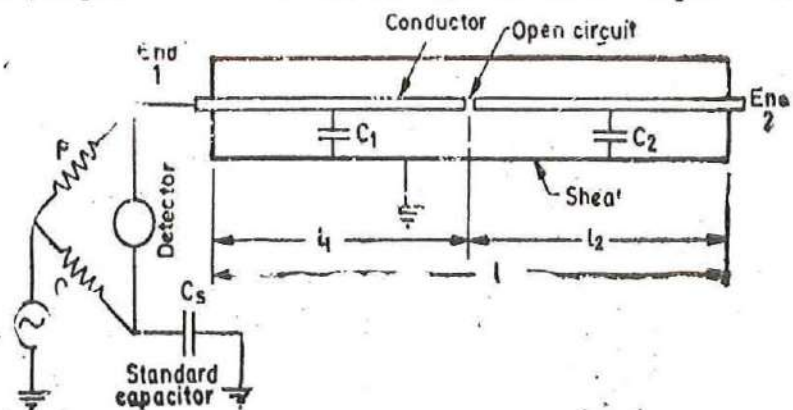

Fig. 15.8. Location of open circuit faults in cables.

is measured in terms of the standard capacitance, C_s , and the non-inductive resistors P and Q . The resistors are adjusted to get balance.

At balance $\frac{P}{Q} = \frac{1/\omega C_1}{1/\omega C_s}$ or capacitance $C_1 = C_s \cdot \frac{Q}{P}$... (15.7)

The location of an open circuit fault by capacitance method using a ballistic galvanometer is illustrated by the following example.

Example 15.5. A cable is 3500 km long and has a capacitance of 700 μF . An open circuit fault occurs on this cable and the fault is located by performing capacitance measurements using a ballistic-galvanometer. The cable is charged to a voltage of 500 V d.c. and then discharged through the ballistic galvanometer which gives an initial deflection of 80° with an Ayrton Shunt setting of 100.

The galvanometer when calibrated without shunt gives an initial deflection of 50° for a charge 1000 μC . Calculate the distance of open circuit fault on the cable from the test end.

Solution. Constant of galvanometer = $\frac{1000}{50} = 20 \mu\text{C/degree}$.

Charge of the cable length on the test end side = $100 \times 20 \times 80 = 160,000 \mu\text{C}$.

Capacitance of the cable length on the test end side $C_1 = \frac{\text{charge}}{\text{voltage}} = \frac{160000}{500} = 320 \mu\text{F}$.

Capacitance per unit length = $\frac{700}{3500} = 0.2 \mu\text{F/km}$.

\therefore Distance of open circuit from test end = $\frac{320}{0.2} = 1600 \text{ km}$.

SYMMETRICAL COMPONENTS AND THEIR MEASUREMENT

15.11. Introduction to Symmetrical Components. An unbalanced system consisting of three phasors can be resolved into three systems of phasors which are each balanced but have different phase sequences. These are referred to as positive sequence, negative sequence and zero sequence systems. They constitute the symmetrical components of the three unbalanced phasors. Thus a

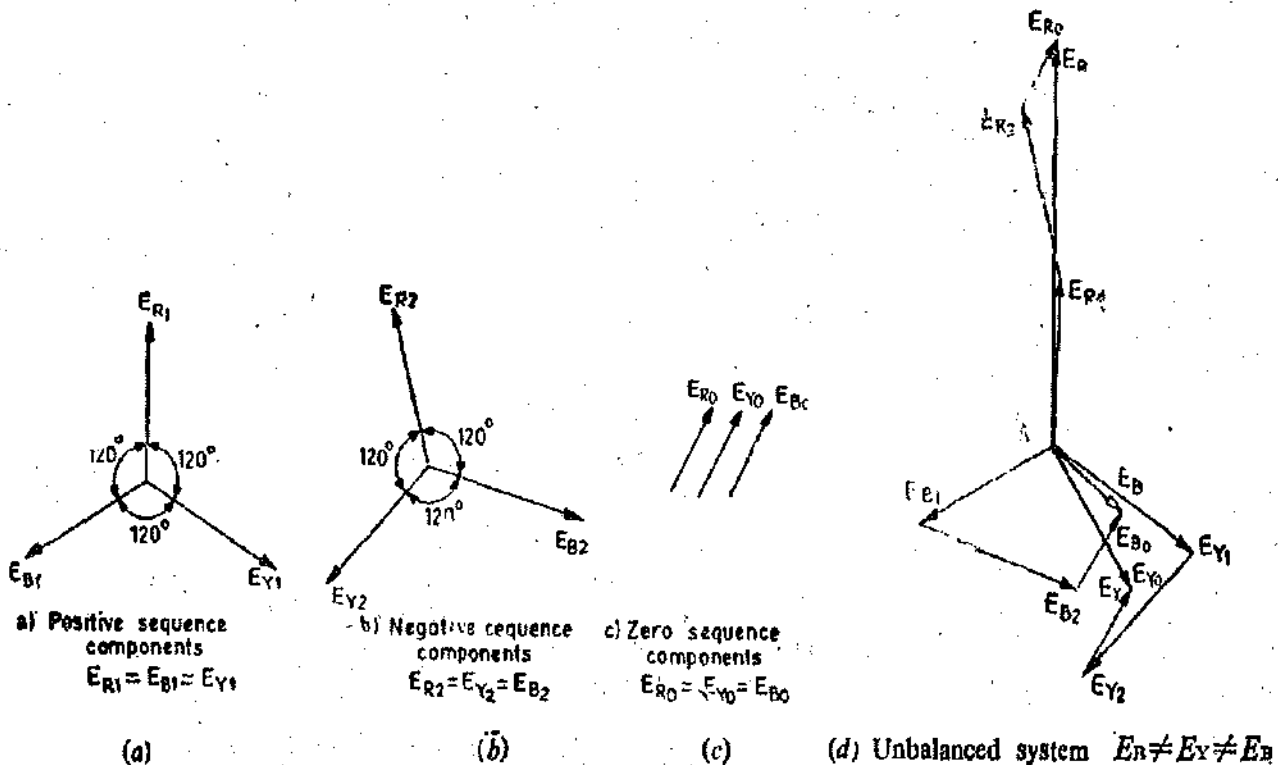

Fig. 15.9. Unbalanced system with its symmetrical components.

system of three unbalanced phasors is split into three components, each of which forms part of a balanced system.

Fig. 15.9 shows the positive, negative and zero sequence systems of phasors in diagrams (a), (b) and (c). The phase sequence for positive sequence phasors is RYB while in the negative sequence it is RBY. The zero sequence phasor components are co-phasal. The three component systems are balanced in themselves, i.e. the positive sequence components E_{R1} , E_{Y1} and E_{B1} are equal in magnitude and so are negative sequence components E_{R2} , E_{Y2} and E_{B2} and zero sequence components E_{R0} , E_{Y0} and E_{B0} .

In Fig. 15.9 (d) the three component phasors E_{R1} , E_{R2} and E_{B0} and E_{Y1} , E_{Y2} and E_{Y0} , and E_{B1} , E_{B2} and E_{B0} are added to give phasors E_R , E_Y and E_B respectively. It is noticed the result is an unbalanced system of phasors E_B , E_Y and E_R . Conversely, the unbalanced system of three phasors E_R , E_Y and E_B can be split up into three balanced systems, i.e. positive, negative and zero sequence systems as shown in diagrams 15.9 (a), (b) and (c).

For the mathematical treatment of symmetrical components an operation 'a' is introduced. The multiplication of a phasor by operator 'a' rotates the phasor by 120° .

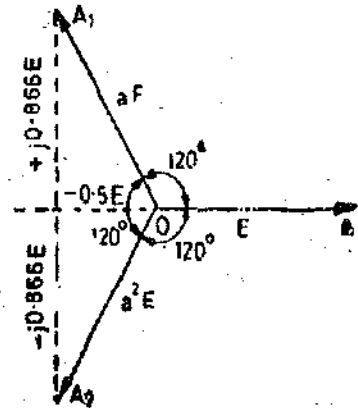

Fig. 15.10

Let us consider Fig. 15.10 in which OA represents a phasor E where $E = E(1 + j0)$.

OA_1 represents a phasor aE and OA_2 represents the phasor a^2E .

Obviously, $OA = E = E(1 + j0) = E$

$$OA_1 = aE = -0.5 E + j0.866 E = (-0.5 + j0.866) E$$

and $OA_2 = a^2E = -0.5 E - j0.866 E = (-0.5 - j0.866) E$

$$\therefore a = 0.5 + j0.866 \quad \dots(15.8)$$

$$\text{and } a^2 = 0.5 - j0.866 \quad \dots(15.9)$$

Now if we multiply phasor $OA_2 (= a^2E)$ by a , we rotate it a further 120° to OA , so that

$$a^3E = E \quad \therefore a^3 = 1 \quad \dots(15.10)$$

Thus summarizing the above results

$$a = -0.5 + j0.866, a^2 = -0.5 - j0.866, a^3 = 1$$

$$a^4 = a^1, a^5 = a^2, a^6 = a^3 = -0.5 - j0.866, \text{ and so on.}$$

$$\text{From above, we have : } a + a^2 + 1 = (-0.5 + j0.866) + (-0.5 - j0.866) + 1 = 0 \quad \dots(15.11)$$

Since the magnitudes of 3 phasors forming each set of symmetrical components are equal, we have the following results :

Positive Sequence System

$$E_{R1}, E_{Y1} = a^2 E_{R1}, \text{ and } E_{B1} = a E_{R1}, \text{ with } E_{R1} = E_{Y1} = E_{B1}$$

Negative Sequence System

$$E_{R2}, E_{Y2} = a E_{R2}, \text{ and } E_{B2} = a^2 E_{R2}, \text{ with } E_{R2} = E_{Y2} = E_{B2}$$

Zero Sequence Components

$$E_{R0} = E_{Y0} = E_{B0}$$

15.12. Calculation of Symmetrical Components. The three phasors forming an unbalanced system may be expressed as :

$$E_R = E_{R0} + E_{R1} + E_{R2} = E_{R0} + E_{R1} + E_{R2}$$

$$E_Y = E_{Y0} + E_{Y1} + E_{Y2} = E_{R0} + a^2 E_{R1} + a E_{R2}$$

$$\text{and } E_B = E_{B0} + E_{B1} + E_{B2} = E_{R0} + a E_{R1} + a^2 E_{R2}$$

The three symmetrical components may be derived in terms of E_R , E_Y and E_B as follows :

$$E_R = E_{R0} + E_{R1} + E_{R2}$$

$$aE_Y = aE_{R0} + a^3E_{R1} + a^2E_{R2} = aE_{R0} + E_{R1} + a^2E_{R2}$$

$$a^2E_Y = a^2E_{R0} + a^4E_{R1} + a^3E_{R2} = a^2E_{R0} + aE_{R1} + E_{R2}$$

$$aE_B = aE_{R0} + a^2E_{R1} + aE_{R2} = aE_{R0} + a^2E_{R1} + E_{R2}$$

$$a^2E_B = a^2E_{R0} + a^3E_{R1} + a^4E_{R2} = a^2E_{R0} + E_{R1} + aE_{R2}$$

$$\begin{aligned} \text{Now } E_R + aE_Y + a^2E_B &= (E_{R0} + E_{R1} + E_{R2}) + (aE_{R0} + E_{R1} + a^2E_{R2}) + (a^2E_{R0} + E_{R1} + aE_{R2}) \\ &= E_{R0}(1 + a + a^2) + 3E_{R1} + E_{R2}(1 + a^2 + a) = 3E_{R1} \text{ as } 1 + a + a^2 = 0 \end{aligned}$$

$$\therefore \text{ Positive sequence component } E_{R1} = \frac{E_R + aE_Y + a^2E_B}{3} \quad \dots(15'12)$$

$$\begin{aligned} \text{We can write : } E_R + a^2E_Y + aE_B &= (E_{R0} + E_{R1} + E_{R2}) + (a^2E_{R0} + aE_{R1} + E_{R2}) + (aE_{R0} + a^2E_{R1} + E_{R2}) \\ &= E_{R0}(1 + a^2 + a) + E_{R1}(1 + a + a^2) + 3E_{R2} = 3E_{R2} \end{aligned}$$

$$\therefore \text{ Negative sequence component } E_{R2} = \frac{E_R + a^2E_Y + aE_B}{3} \quad \dots(15'13)$$

For calculation of zero sequence components

$$\begin{aligned} E_R + E_Y + E_B &= (E_{R0} + E_{R1} + E_{R2}) + (E_{R0} + a^2E_{R1} + aE_{R2}) + (E_{R0} + aE_{R1} + a^2E_{R2}) \\ &= 3E_{R0} + E_{R1}(1 + a^2 + a) + E_{R2}(1 + a + a^2) = 3E_{R0} \end{aligned}$$

$$\therefore \text{ Zero sequence component } E_{R0} = \frac{E_R + E_Y + E_B}{3} \quad \dots(15'14)$$

The above equations have been derived for a system consisting of three unbalanced voltage phasors, but they apply in exactly the same way to current phasors and impedances.

15'13. Measurement of Symmetrical Components. The measurement of symmetrical components of the currents and voltages in an unbalanced three phase system is based upon relationships derived in the preceding sections. These relationships suggest that appropriate phase shifting circuits be introduced to measure the components. These phase shifting circuits include resistors, inductors and capacitors of suitable values so that appropriate phase shifts may be carried out.

It is evident that the measuring circuits be isolated from the main system. This is done by using instrument transformers.

15'14. Measurement of Positive Sequence Component of Current. From Eqn. 15'12 ; the positive sequence component of current of phase R is

$$I_{R1} = \frac{I_R + aI_Y + a^2I_B}{3}$$

The above relation implies that the phase of I_Y be advanced by 120° and that of I_B by 240° . To advance the phase of I_Y by 120° , its phase is reversed, (i.e. advanced by 180°) and then causing to lag by 60° . Similarly to advance the phase of I_B by 240° , this phase is reversed and then caused to advance by 60° . A current transformer is inserted in all the three phases as shown in Fig. 15'11. In order to add the three currents, the secondaries of three current transformers feed three primary windings of a summation transformer.

The C.T. in line R has resistance inserted in its circuit and this fixes the phase of its current. The C.T. in line Y has both resistance and inductance inserted in its circuit, the values of these being such that they lag the current 60° behind the current in the first C.T. if both were supplied from the same line. The connections of this C.T. are also reversed to give a displacement of 180° . The C.T. in line B is provided with a resistance and capacitance where values are such that they cause the phase displacement of 60° . The connections of this C.T. are also reversed.

Since the C.Ts. feed three windings mounted on the same limb of the summation transformer, the output of this summation transformer is proportional $(I_R + aI_Y + a^2I_B)$ and hence to the positive sequence component of current. This output is read by an ammeter.

15'15. Measurement of Negative Sequence Component of Current. The negative sequence component of current of line R is:

$$I_{R2} = \frac{I_R + a^2 I_Y + a I_B}{3}$$

(See Eqn. 15'13)

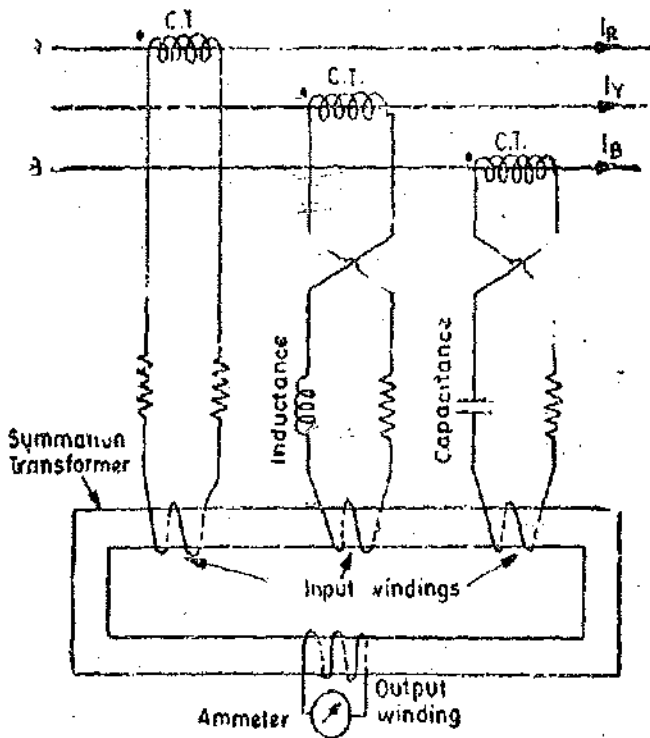

Fig. 15'11. Measurement of positive sequence component of current.

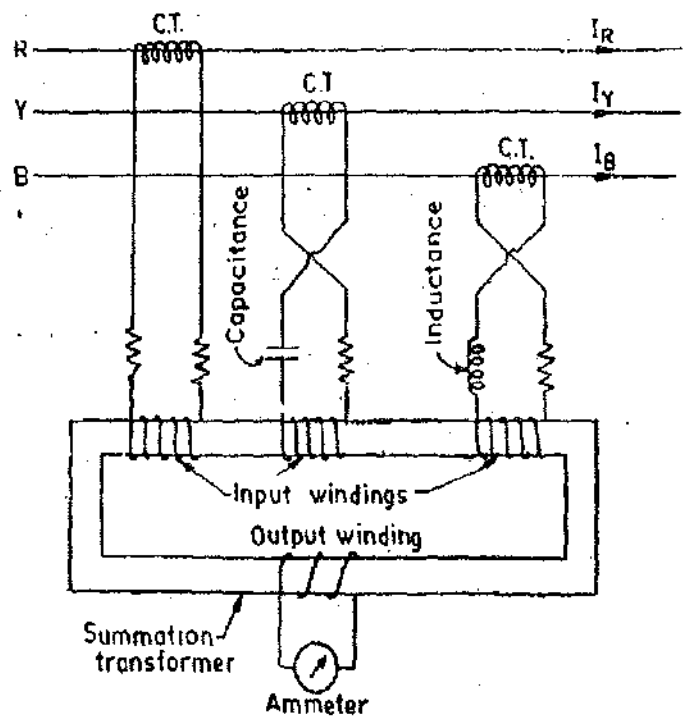

Fig. 15'12. Measurement of negative sequence component of current.

Thus to read negative sequence component of current of line R, the current of line Y must be advanced by 240° and that of line B by 120°. The arrangement of Fig. 15'11 is used. All that is necessary is to connect the capacitance in circuit of C.T. in line Y and inductance in the circuit of C.T. in line B. This causes the required phase displacements. The output of summation transformer in this case is proportional to negative sequence component of current. The connections are shown in Fig. 15'12.

15'16. Measurement of Zero Sequence Component of Current. Zero sequence component of current

$$I_{R0} = \frac{I_R + I_Y + I_B}{3}$$

(See Eqn. 15'14)

Thus to measure zero sequence component of current, we must have the phasor addition of the three currents. This is done as shown in Fig. 15'13. The secondaries of three C.T.s. are connected in parallel with an ammeter. The positive and negative phase sequence currents among the secondary windings of the three transformers without affecting the ammeter. But the three zero sequence currents being all in phase, send current through the ammeter, which therefore indicates three times the zero sequence current component in each winding. The reading of the ammeter when multiplied by ratio of C.T. gives three times the zero sequence component of the unbalanced system.

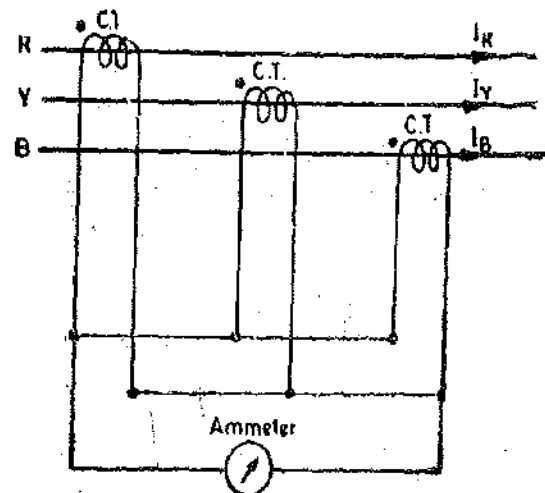

Fig. 15'13. Measurement of zero sequence component of current.

15'17. Measurement of Positive-Sequence Component of Voltage. When a system contains zero sequence components of voltage, these can be eliminated by using a delta-star connected potential transformer for the measuring circuit. The three windings of the delta connected primary form a closed circuit, so that the phasor sum of three voltages must add to zero. A closed

15.20. Vector Meter. One of the most important meter in a power station is the **Vector Meter**. It is an induction type indicating meter which incorporates arrangements for simultaneous indications of kW, kVAR, power factor and current which are shown on a dial. It consists of an arrangement which uses a combination of a wattmeter element with a pointer which can be moved in a straight line and a varmeter element also with a pointer which can move in a straight line at right angles to and over the same area transversed by the pointer of the wattmeter.

This instrument enables the engineers in the power stations to ensure that the generators are operating within their **Stability Limits**. The safe working load of a generator is partly dependent upon the field current which in turn determines the range of leading and lagging power factors over which the machine may safely be operated without falling out of synchronism and partly on heating considerations. The maximum field current (hence maximum lagging power factor) is determined by the heating considerations and the minimum field current (hence maximum leading power factor) is determined by the steady state stability limit. Stator current also has to be kept within safe limits. If, therefore, a curve (called **Operating Chart**) associating output load with the above limits of operation is superimposed upon the scale, the point of intersection of kW and kVAR pointers, if kept within the boundary enclosed by the operating charts, will ensure that the machine is working within safe design limits. An operating chart is shown in Fig. 15.17.

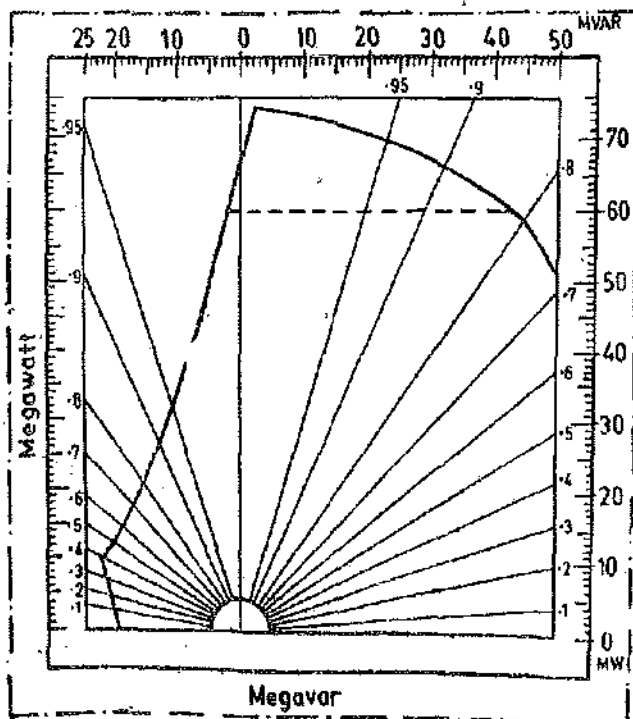

Fig. 15.17. Operating chart (Vector meter scale with stability limits).

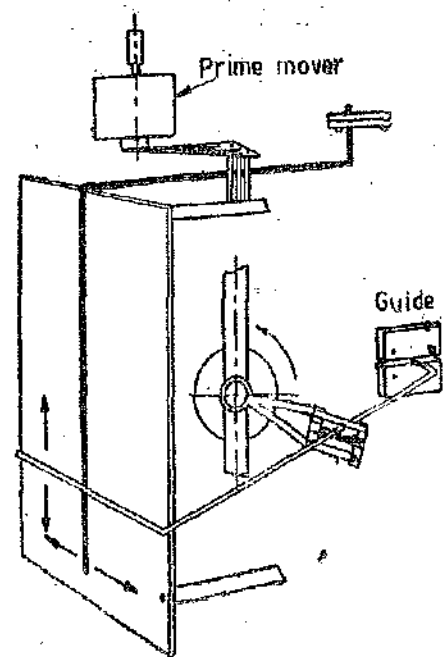

Fig. 15.18. Principle of straight-line movement.

The vector meter uses a wattmeter element. This wattmeter element is an induction type wattmeter as explained in Art. 10.15 page 356. The principle of straight line movement is shown in Fig. 15.18. A portion of the pointer arm at right angles to the dial is pivoted on a light cradle which is, in turn, mounted on the movement. The movement while rotating in the direction shown, moves the pointer across the dial with the other end of the pointer sliding down in its guides.

For three phase balanced loads, single element instruments are used. The measuring elements are usually centre zero type for interconnected systems. These instruments are used because indication of export and import power and reactive power is required. For generator circuits, offset zero movements are provided so that approximately one quadrant (representing forward generated power) is extended over the full dial.

A series of circles are drawn to represent a scale of current which is evaluated in relation to the normal voltage of the system. The length of the line drawn from the centre of the

circles to the point of intersection of the kW and kVAR pointers, indicates the value of the stator current. The angle between this line and the vertical represents the power factor of the system, which may be read off from the indications on the edge of the dial.

A shaft position indicator (*i.e.*, power angle indicator) is also used in modern electric plants. This instrument indicates the position of the rotor with respect to the stator voltage at the generator terminals. The power angle is indicative of the stability which can be controlled according to design limits of the machine.

UNSOLVED PROBLEMS

1. A feeder cable 250 metre long has a fault to earth. The fault is localized by the following resistance measurements between earth and one end of cable (*a*) distant end insulated, 6.95Ω (*b*) distant end earthed, 1.71Ω . The cable has a total resistance of 1.80Ω . Find the resistance of fault and its distance from test end.
2. In a Murray loop test for ground fault on a 500 metre long cable having a resistance of $1.6 \Omega/\text{km}$, the faulty cable is looped with a sound cable of same length and cross-section. If resistances of ratio arms are 3 : 1, calculate the distance of the fault from the test end. [Ans. 250 m]
3. A telephone line, 5 km long, has an earth fault 2.3 km from test end. If the resistance of the lines per km is 4.0Ω , what value of variable resistance will give balance in a Varley loop test. The ratio arms are equal. [Ans. 21.6Ω]
4. A telephone wire having a resistance of $14.6 \Omega/\text{km}$, develops a fault to earth. When looped with a sound wire of the same length, the total resistance is found to be 56Ω . If the value of variable resistance is 16.3 at balance in a Varley loop test with ratio arms equal, calculate the distance of fault. [Ans. 1.36 km]
5. A single core cable 10 km long has a capacitance $0.2 \mu\text{F}/\text{km}$. It develops an open circuit fault. This fault is located by a capacitance bridge as shown in Fig. 15.7. At balance the ratio of *P* : *Q* is 1 : 2 and the value of standard variable capacitor $0.41 \mu\text{F}$. Calculate the distance of fault from test end. [Ans. 4.1 km]
6. The zero sequence currents in a 3 phase unbalanced system are found by connecting the secondaries of three CTs in parallel with an ammeter. If ratio of CTs is 500 and the reading of the ammeter is 2.76 A , find the value of zero sequence current in each phase of the system. [Ans. 460 A]

A.C. Bridges

16'1. Introduction. Alternating current bridge methods are of outstanding importance for measurement of electrical quantities. Measurements of inductance, capacitance, storage factor, loss factor etc. may be made conveniently and accurately by employing a.c. bridge networks.

The a.c. bridge is a natural outgrowth of the Wheatstone bridge. An a.c. bridge, in its basic form, consists of four arms, a source of excitation, and a balance detector. In an a.c. bridge each of the four arms is an impedance, and the battery and the galvanometer of the Wheatstone bridge are replaced respectively by an a.c. source and a detector sensitive to small alternating potential differences.

16'2. Sources and Detectors. For measurements at low frequencies, the power line may act as the source of supply to the bridge circuits. For higher frequencies electronic oscillators are universally used as bridge source supplies. These oscillators have the advantage that the frequency is constant, easily adjustable, and determinable with accuracy. The waveform is very close to a sine wave, and their power output is sufficient for most bridge measurements. A typical oscillator has a frequency range of 40 Hz to 125 kHz with a power output of 7 W.

The detectors commonly used for a.c. bridges are (i) Head phones, (ii) Vibration galvanometers, and (iii) Tuneable amplifier detectors. Head phones are widely used as detectors at frequencies of 250 Hz and over upto 3 or 4 kHz. They are most sensitive detectors for this frequency range.

When working at a single frequency a tuned detector normally gives the greatest sensitivity and discrimination against harmonics in the supply. Vibration galvanometers are extremely useful in power and low audio frequency ranges. Vibration galvanometers are manufactured to work at various frequencies ranging from 5 Hz to 1000 Hz but are most commonly used below 200 Hz as below this frequency they are more sensitive than the head phones.

Tuneable amplifier detectors are the most versatile of the detectors. The transistor amplifier can be tuned electrically and thus can be made to respond to a narrow bandwidth at the bridge frequency. The output of the amplifier is fed to a pointer type of instrument. This detector can be used, over a frequency range of 10 Hz to 100 kHz.

For ordinary a.c. bridge measurements of inductance and capacitance, a fixed frequency oscillator of 1000 Hz and output of about 1 W is adequate. For more specialised work continuously variable oscillators are preferable with outputs upto 5 W. The high power may be necessary on some occasions, but in practice it is better to limit the power supplied to the bridge. Another practice which is usually followed is to use an untuned amplifier detector. The balance detection is sensed both orally by head phones, and visually by a pointer galvanometer having a logarithmic deflection (to avoid damage to the galvanometer which may be caused by unbalance).

16'3. General Equation for Bridge Balance. Fig. 16'1 shows basic a.c. bridge. The four arms of the bridge are impedances Z_1 , Z_2 , Z_3 and Z_4 .

The conditions for balance of bridge require that there should be no current through the detector. This requires that the potential difference between points b and d should be zero. This will be the case when the voltage drop from a to b equals to voltage drop from a to d , both in magnitude and phase. In complex notation we can, thus, write :

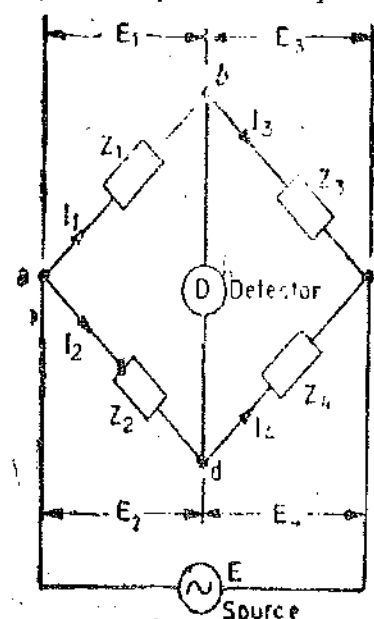

Fig. 16'1. Basic a.c. bridge network.

$$E_1 = E_2 \quad \dots(16'1)$$

$$\text{or } I_1 Z_1 = I_2 Z_2 \quad \dots(16'2)$$

$$\text{Also at balance, } I_1 = I_3 = \frac{E}{Z_1 + Z_2} \quad \dots(16'3)$$

$$\text{and } I_2 = I_4 = \frac{E}{Z_2 + Z_4} \quad \dots(16'4)$$

Substitution of Eqns. 16'3 and 16'4 into Eqn. 16'2 gives :

$$Z_1 Z_4 = Z_2 Z_3 \quad \dots(16'5)$$

or when using admittances instead of impedances

$$Y_1 Y_4 = Y_2 Y_3 \quad \dots(16'6)$$

Eqns. 16'5 and 16'6 represent the basic equations for balance of an a.c. bridge. Eqn. 16'5 is convenient to use when dealing with series elements of a bridge while Eqn. 16'6 is useful when dealing with parallel elements.

Eqn. 16'5 states that the product of impedances of one pair of opposite arms must equal the product of impedances of the other pair of opposite arms expressed in complex notation. This means that both magnitudes and the phase angles of the impedances must be taken into account.

Considering the polar form, the impedance can be written as $Z = Z/\theta$, where Z represents the magnitude and θ represents the phase angle of the complex impedance. Now Eqn. 16'5 can be re-written in the form

$$(Z_1/\theta_1)(Z_4/\theta_4) = (Z_2/\theta_2)(Z_3/\theta_3) \quad \dots(16'7)$$

Thus for balance, we must have :

$$Z_1 Z_4 / \theta_1 + \theta_4 = Z_2 Z_3 / \theta_2 + \theta_3 \quad \dots(16'8)$$

Eqn. 16'8 shows that two conditions must be satisfied simultaneously when balancing an a.c. bridge. The first condition is that the magnitude of impedances satisfy the relationship :

$$Z_1 Z_4 = Z_2 Z_3 \quad \dots(16'9)$$

The second condition is that the phase angles of impedances satisfy the relationship :

$$\angle \theta_1 + \angle \theta_4 = \angle \theta_2 + \angle \theta_3 \quad \dots(16'10)$$

The phase angles are positive for an inductive impedance and negative for capacitive impedance.

If we work in terms of rectangular co-ordinates, we have

$$Z_1 = R_1 + jX_1 ; \quad Z_2 = R_2 + jX_2 ;$$

$$Z_3 = R_3 + jX_3 \text{ and } Z_4 = R_4 + jX_4.$$

Thus from Eq. 16'5, for balance

$$Z_1 Z_4 = Z_2 Z_3$$

$$\text{or } (R_1 + jX_1)(R_4 + jX_4) = (R_2 + jX_2)(R_3 + jX_3)$$

$$\text{or } R_1 R_4 - X_1 X_4 + j(X_1 R_4 + X_4 R_1) = R_2 R_3 - X_2 X_3 + j(X_2 R_3 + X_3 R_2) \quad \dots(16'11)$$

Eqn. 16'11 is a complex equation and a complex equation is satisfied only if real and imaginary parts of each side of the equation are separately equal. Thus, for balance :

$$R_1 R_4 - X_1 X_4 = R_2 R_3 - X_2 X_3 \quad \dots(16'12)$$

$$\text{and } X_1 R_4 + X_4 R_1 = X_2 R_3 + X_3 R_2 \quad \dots(16'13)$$

Thus there are two independent conditions for balance and both of them must be satisfied.

Example 16'1. The four impedances of an a.c. bridge shown in Fig. 16'1 are :

$$Z_1 = 400 \Omega / 50^\circ ; Z_2 = 200 \Omega / 40^\circ ; Z_3 = 800 / -50^\circ ; Z_4 = 400 \Omega / 20^\circ.$$

Find out whether the bridge is balanced under these conditions or not.

Solution. Applying the first condition of balance for magnitudes :

$$Z_1 Z_4 = Z_2 Z_3$$

Now $Z_1 Z_4 = 400 \times 400 = 160,000$ and $Z_2 Z_3 = 200 \times 800 = 160,000$.

$\therefore Z_1 Z_4 = Z_2 Z_3$. Thus the first condition is satisfied.

Applying the second condition for balance required for phase : $\theta_1 + \theta_4 = \theta_2 + \theta_3$

Now $\theta_1 + \theta_4 = 50^\circ + 20^\circ = 70^\circ$ and $\theta_2 + \theta_3 = 40^\circ - 50^\circ = -10^\circ$.

This indicates that the condition for phase relationship is not satisfied and therefore the bridge is unbalanced even though the condition for equality of magnitudes is satisfied.

Example 16'2. An a.c. bridge circuit working at 1000 Hz is shown in Fig. 16'1. Arm *ab* is a 0.2 μ F pure capacitance ; arm *bc* is a 500 Ω pure resistance ; arm *cd* contains an unknown impedance and arm *da* has a 300 Ω resistance in parallel with a 0.1 μ F capacitor. Find the *R* and *C* or *L* constants of arm *cd* considering it as a series circuit.

Solution. Impedance of arm *ab* is :

$$Z_1 = \frac{1}{2\pi f C_1} = \frac{1}{2\pi \times 1000 \times 0.2 \times 10^{-6}} = 800 \Omega$$

and $Z_1 = 800 / -90^\circ \Omega$ since it is a pure capacitance.

Impedance of arm *bc* is $Z_2 = 500 \Omega$

or $Z_2 = 500 / 0^\circ$ since it is a pure resistance.

Arm *da* contains a 300 Ω resistance in parallel with a 0.1 μ F capacitance.

$$Z_3 = \frac{R_2}{1 + j\omega C_2 R_2} = \frac{300}{1 + j(2\pi \times 1000 \times 0.1 \times 10^{-6} \times 300)} = 294.8 - j55.4 = 300 / -10.6^\circ$$

For balance $Z_1 Z_4 = Z_2 Z_3$

\therefore Impedance of *cd* required for balance

$$Z_4 = \frac{Z_2 Z_3}{Z_1} = \frac{360 \times 500}{800} / -10.6^\circ + 0^\circ + 90^\circ = 187.5 / 18.4^\circ$$

The positive angle for impedance indicates that the branch consists of a series *R-L* circuit.

Resistance $R_4 = 187.5 \cos 18.4^\circ = 178.7 \Omega$

Inductive reactance $X_4 = 187.5 \sin 18.4^\circ = 59.6 \Omega$.

Inductance $L_4 = \frac{59.6}{2\pi \times 1000} \text{ H} = 29.2 \text{ mH}$.

15.4. General form of an A.C. Bridge. As an example let us consider the bridge circuit of Fig. 16'2. R_3 and R_4 are non-inductive resistances L_1 and L_2 are inductances of the negligible resistance and R_1 and R_2 are non-inductive resistors.

Therefore at balance,

$$Z_1 Z_4 = Z_2 Z_3 \text{ or } (R_4 + j\omega L_1) R_4 = (R_2 + j\omega L_2) R_3.$$

Equating the real and imaginary parts separately, we have :

$$R_1 R_4 = R_2 R_3 \text{ or } R_1 = \frac{R_3}{R_4} R_2 \quad \dots (16'14)$$

$$\text{and } j\omega L_1 R_4 = j\omega L_2 R_3 \text{ or } L_1 = \frac{R_3}{R_4} L_2 \quad \dots (16'15)$$

Thus if L_1 and R_1 are unknown, the above bridge may be used to measure these quantities in terms of R_2 , R_3 , R_4 and L_2 . We may deduce several important conclusions from the above simple example. They are :

1. Two balance equations are always obtained for an a.c. bridge circuit. This follows from the fact that for balance in an

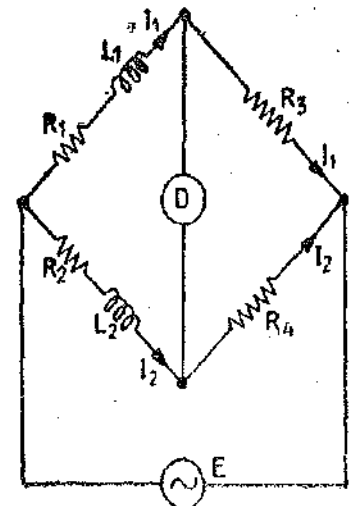

Fig. 16'2. Inductance comparison Bridge.

a.c. bridge, both magnitude and phase relationships must be satisfied. This requires that real and imaginary terms must be separated, which gives two equations to be satisfied for balance.

2. The two balance equations enable us to know two unknown quantities. The two quantities are usually a resistance and an inductance or a capacitance.

3. In order to satisfy both conditions for balance and for convenience of manipulation, the bridge must contain two variable elements in its configuration. For greatest convenience, each of the balance equations must contain one variable element, and one only. The equations are then said to be independent. In the bridge of Fig. 16'2, R_2 and L_2 are obvious choice as variable elements since L_2 does not appear in the expression for R_1 and R_2 does not figure in the expression for L_1 and hence the two balance equations are independent. The technique of balancing is to adjust L_2 till a minimum indication is obtained on the detector, then to adjust R_2 until a new smaller minimum indication is obtained. Then L_2 and R_2 are alternately adjusted until the detector shows no indication.

The process of alternate manipulation of two variable elements is rather typical of the general balancing procedures adopted in most a.c. bridges. When two variables are chosen such that the two balance equations are no longer independent, the bridge has a very poor convergence of balance and gives the effect of sliding balance. The term **Sliding Balance** describes a condition of interaction between the two controls. Thus when we balance with R_2 , then go to R_3 and back to R_2 for adjustment, we find a new apparent balance point. Thus the balance point appears to move, or, slide and settles only gradually to its final point after many adjustments. It may be emphasised here that in case the two balance conditions are independent, not more than two or three adjustments of the variable elements would be necessary to obtain balance. In case we choose the two variable components such that the two equations are not independent the balance procedure becomes laborious and time consuming. For example, if we choose R_2 and R_3 as variable elements, the two equations are no longer independent since R_3 appears in both the equations. Thus R_3 is adjusted to satisfy Eqn. 16'15, its value may be becoming farther removed from that which satisfies Eqn. 16'14. There are two adjustments, one resistive and the other reactive that must be made to secure balance. For the usual magnitude responsive detector, these adjustments must be made alternately until they converge on the balance point. The convergence to balance point is best when both the variable elements are in the same arm.

4. In this bridge circuit balance equations are independent of frequency. This is often a considerable advantage in an a.c. bridge, for the exact value of the source frequency need not then be known. Also, if a bridge is balanced for a fundamental frequency it should also be balanced for any harmonic and the wave-form of the source need not be perfectly sinusoidal. On the other hand, it must be realized that the effective inductance and resistance for example, of a coil, vary with frequency (see pages 105, 106, 114 & 115), so that a bridge balanced at a fundamental frequency is never, in practice, truly balanced for the harmonics. To minimize difficulties due to this the source wave-form should be good, and it is often an advantage to use a detector tuned to the fundamental frequency. Further while the disappearance of the frequency factor is of advantage in many bridges, some bridges derive their usefulness from the presence of a frequency factor; such bridges must then be supplied from a source with very good wave-form and high frequency stability. Alternatively, they may be used to determine frequency.

MEASUREMENT OF SELF INDUCTANCE

16'5. Maxwell's Inductance Bridge. This bridge circuit measures an inductance by comparison with a variable standard self-inductance. The connections and the phasor diagrams for balance conditions are shown in Fig. 16'3.

Let L_1 = unknown inductance of resistance R_1 ,

L_2 = variable inductance of fixed resistance r_2 ,

R_3 = variable resistance connected in series with inductor L_2 ,

and R_3, R_4 = known non-inductive resistances.

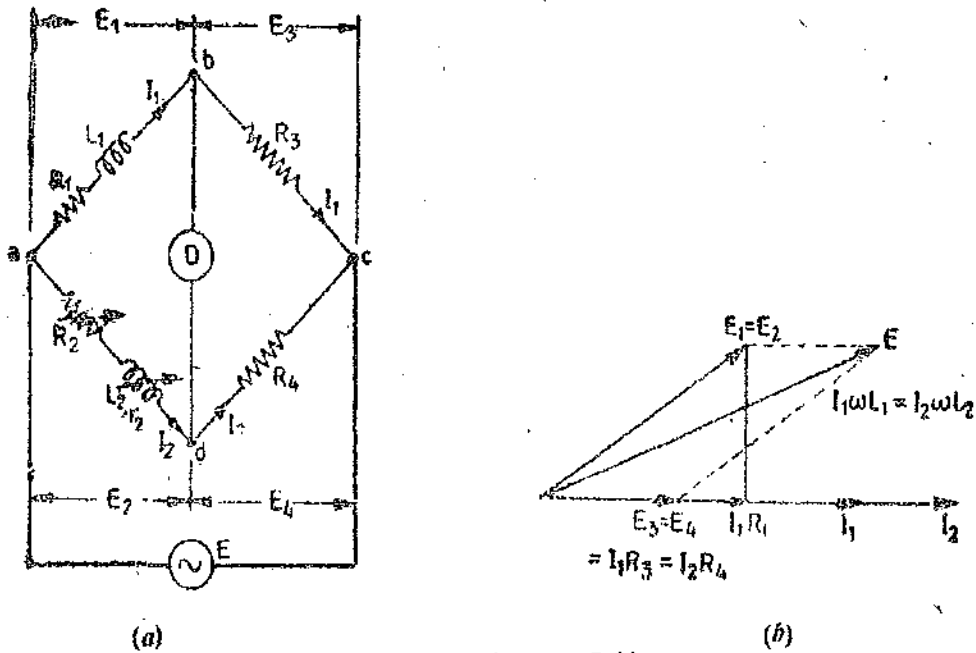

Fig. 16.3. Maxwell's inductance Bridge.

The theory of this bridge has been dealt with in Art. 16.4. At balance,

$$L_1 = \frac{R_3}{R_4} L_2 \quad \dots(16.16)$$

and

$$R_1 = \frac{R_3}{R_4} (R_2 + r_2) \quad \dots(16.17)$$

Resistors R_3 and R_4 normally a selection of values from 10, 100, 1000 and 10,000 Ω . r_2 is a decade resistance box. In some cases, an additional known resistance may have to be inserted in series with unknown coil in order to obtain balance.

16.6. Maxwell's Inductance-Capacitance Bridge. In this bridge, an inductance is measured by comparison with a standard variable capacitance. The connections and the phasor diagram at the balance conditions are given in Fig. 16.4.

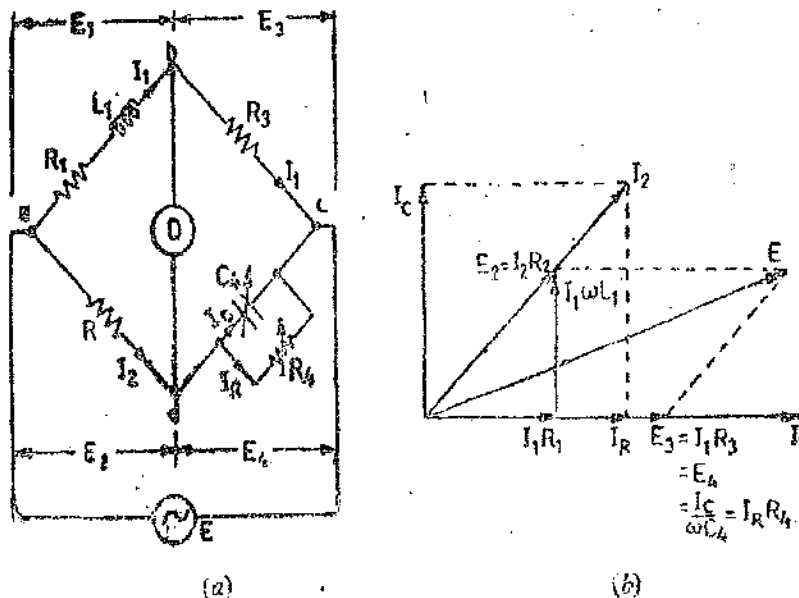

Fig. 16.4. Maxwell's inductance capacitance Bridge.

Let L_1 = unknown inductance, R_1 = effective resistance of inductor L_1 ,
 R_2, R_3, R_4 = known non-inductive resistances, and C_4 = variable standard capacitor.

Writing the equation for balance

$$(R_1 + j\omega L_1) \left(\frac{R_4}{1 + j\omega C_4 R_4} \right) = R_2 R_3 \quad \text{or} \quad R_1 R_4 + j\omega L_1 R_4 = R_2 R_3 + j\omega R_2 R_3 C_4 R_4.$$

Separating the real and imaginary terms, we have : $R_1 = \frac{R_2 R_3}{R_4}$... (16'18)

and $L_1 = R_2 R_3 C_4$... (16'19)

Thus we have two variables R_4 and C_4 which appear in one of the two balance equations and hence the two equations are independent.

The expression for Q factor $Q = \frac{\omega L_1}{R_1} = \omega C_4 R_4$... (16'20)

Advantages. The advantages of this bridge are :

1. The two balance equations are independent if we choose R_4 and C_4 as variable elements.
2. The frequency does not appear in any of the two equations.
3. This bridge yields simple expression for unknowns L_1 and R_1 in terms of known bridge elements. Physically R_2 and R_3 are each, say, 10, 100, 1000 or 10,000 Ω and their value is selected to give suitable value of product $R_2 R_3$ which appears in both the balance equations; C_4 is decade capacitor and R_4 a decade resistor.

The simplicity of the bridge can be appreciated by the following example. Suppose the product $R_2 R_3$ is 10^6 . The inductance

$$L_1 = C_4 \times 10^6 \quad (\text{See Eqn. 16'19})$$

Thus when balance is achieved the value of C_4 in μF directly gives the value of inductance in H.

4. The Maxwell's inductance—capacitance bridge is very useful for measurement of a wide range of inductance at power and audio frequencies.

Disadvantages. The main disadvantages of this bridge are :

1. This bridge requires a variable standard capacitor which may be very expensive if calibrated to a high degree of accuracy. Therefore sometimes a fixed standard capacitor is used, either because a variable capacitor is not available or because fixed capacitors have a higher degree of accuracy and are less expensive than the variable ones. The balance adjustments are then done by :

(a) either varying R_2 and R_4 and since R_2 appears in both the balance equations, the balance adjustments become difficult ; or

(b) putting an additional resistance in series with the inductance under measurement and then varying this resistance and R_4 .

2. The bridge is limited to measurement of low Q coils, ($1 < Q < 10$). It is clear from Eqn. 16'20 that the measurement of high Q coils demands a large value for resistance R_4 , perhaps 10^6 or $10^6 \Omega$. The resistance boxes of such high values are very expensive. Thus for values of $Q > 10$, the Maxwell's bridge is unsuitable.

The Maxwell's bridge is also unsuited for coils with a very low value of Q (i.e. $Q < 1$). Q values of this magnitude occur in inductive resistors, or in an R.F. coil if measured at low frequencies. The difficulty in measurement occurs on account of labour involved in obtaining balance since normally a fixed capacitor is used and balance is obtained by manipulating resistances R_2 and R_4 alternately. This difficulty is explained as below :

From Eqns. 16'18 and 16'19, it is clear that R_2 enters into both the expressions. A preliminary inductive balance is made with R_2 , and then R_4 is varied to give a resistive balance which is dependent on the R_2 setting. Accordingly when R_2 is changed for a second inductive balance, the resistive balance is disturbed, and moves to a new value giving slow "convergence" to balance. This is

particularly true of a low Q coil, for which resistance is prominent (as $Q = \omega L/R$). Thus a sliding balance condition prevails and it takes many manipulations to achieve balance for low Q coils with a Maxwell's bridge.

From the above discussions we conclude that a Maxwell's bridge is suited for measurements of only medium Q coils.

16.7. Hay's Bridge. The Hay's bridge is a modification of Maxwell's bridge. The connection diagram and the phasor diagram for this bridge are shown in Fig 16.5. This bridge uses a resistance in series with the standard capacitor (unlike the Maxwell's bridge which uses a resistance in parallel with the capacitor).

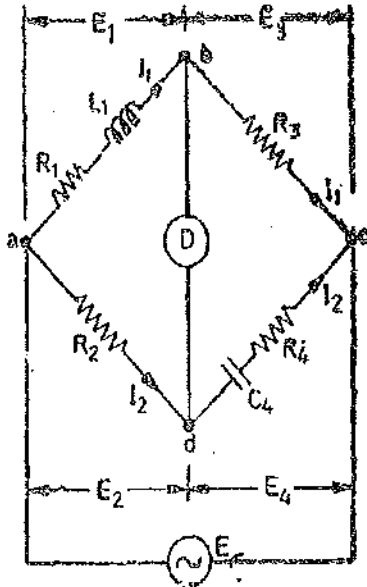

(a)

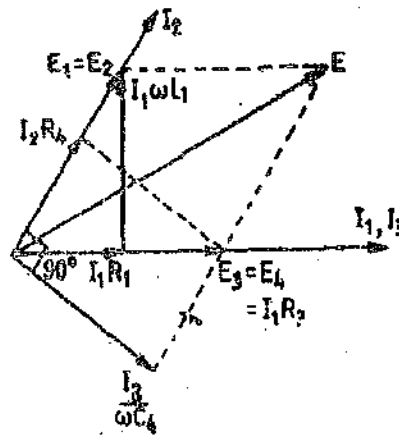

(b)

Fig. 16.5. Hay's Bridge.

Let L_1 = unknown inductance having a resistance R_1 ,
 R_2, R_3, R_4 = known non-inductive resistances,
 and C_4 = standard capacitor.

At balance,

$$(R_1 + j\omega L_1)(R_4 - j/\omega C_4) = R_2 R_3 \quad \text{or} \quad R_1 R_4 + \frac{L_1}{C_4} + j\omega L_1 R_4 - \frac{jR_1}{\omega C_4} = R_2 R_3.$$

Separating the real and imaginary terms, we obtain :

$$R_1 R_4 + \frac{L_1}{C_4} = R_2 R_3 \quad \text{and} \quad L_1 = \frac{R_1}{\omega^2 R_4 C_4}$$

Solving the above two equations, we have :
$$L_1 = \frac{R_2 R_3 C_4}{1 + \omega^2 C_4^2 R_4^2} \quad \dots(16.21)$$

and
$$R_1 = \frac{\omega^2 R_2 R_3 R_4 C_4^2}{1 + \omega^2 C_4^2 R_4^2} \quad \dots(16.22)$$

The Q factor of the coil is :
$$Q = \frac{\omega L_1}{R_1} = \frac{1}{\omega C_4 R_4} \quad \dots(16.23)$$

The expressions for the unknown inductance and resistance contain the frequency term. There

fore it appears that the frequency of the source of supply to the bridge must be accurately known. This is not true for the inductance when a high Q coil is being measured, as is explained below :

Now
$$L_1 = \frac{R_2 R_3 C_4}{1 + \omega^2 C_4^2 R_4^2}$$

but
$$Q = \frac{1}{\omega C_4 R_4}, \text{ and therefore } L_1 = \frac{R_2 R_3 C_4}{1 + (1/Q)^2} \dots (16.24)$$

For a value of Q greater than 10, the term $(1/Q)^2$ will be smaller than 1/100 and can be neglected.

Therefore Eqn. 16.25 reduces to $L_1 = R_2 R_3 C_4 \dots (16.25)$ which is the same as for a Maxwell's bridge.

Advantages :

1. This bridge gives very simple expression for unknown inductance for high Q coils and is suitable for coils having $Q > 10$.
2. This bridge also gives a simple expression for Q factor.
3. If we examine the expression for Q factor : $Q = \frac{1}{\omega C_4 R_4}$,

we find that the resistance R_4 appears in the denominator and hence for high Q coils, its value should be small. Thus this bridge requires only a low value resistor for R_4 , whereas the Maxwell's bridge requires a parallel resistor, R_4 , of a very high value.

Disadvantages :

1. The Hay's bridge is suited for the measurement of high Q inductors, especially those inductors having a Q greater than 10. For inductors having Q values smaller than 10, the term $(1/Q)^2$ in the expression for inductance L_1 (Eqn. 16.24) becomes rather important and thus cannot be neglected. Hence this bridge is not suited for measurement of coils having Q less than 10 and for these applications a Maxwell's bridge is more suited.

16.8. Anderson's Bridge. This bridge, in fact, is a modification of the Maxwell's inductance-capacitance bridge. In this method, the self inductance is measured in terms of a standard capacitor. This method is applicable for precise measurement of self-inductance over a very wide range of values.

Fig. 16'6 shows the connections and the phasor diagram of the bridge for balanced conditions.

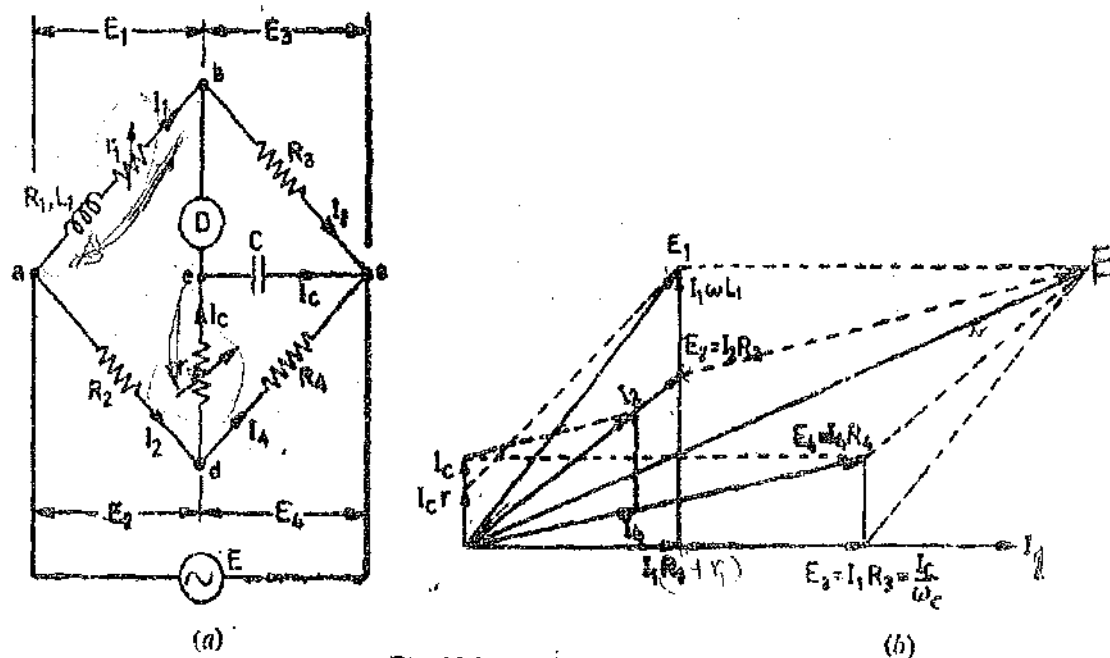

Fig. 16'6. Anderson's Bridge.

Let L_1 = self inductance to be measured, R_1 = resistance of self-inductor,
 r_1 = resistance connected in series with self-inductor,
 r, R_2, R_3, R_4 = known non-inductive resistances, and C = fixed standard capacitor.

At balance, $I_1 = I_2$ and $I_2 = I_c + I_4$.

$$\text{Now } I_1 R_3 = I_c \times \frac{1}{j\omega C} \quad \therefore I_c = I_1 j\omega C R_3.$$

Writing the other balance equations

$$I_1(r_1 + R_1 + j\omega L_1) = I_2 R_2 + I_c r \quad \text{and} \quad I_c \left(r + \frac{1}{j\omega C} \right) = (I_2 - I_c) R_4.$$

Substituting the value of I_c in the above equations, we have :

$$I_1(r_1 + C_1 + j\omega L_1) = I_2 R_2 + I_1 j\omega C R_3 r \quad \text{or} \quad I_1(r_1 + R_1 + j\omega L_1 - j\omega C R_3 r) = I_2 R_2 \quad \dots(i)$$

$$\text{and } j\omega C R_3 I_1 \left(r + \frac{1}{j\omega C} \right) = (I_2 - I_1 j\omega C R_3) R_4 \quad \text{or} \quad I_1(j\omega C R_3 r + j\omega C R_3 R_4 + R_3) = I_2 R_4 \quad \dots(ii)$$

From Eqns. (i) and (ii), we obtain

$$I_1(r_1 + R_1 + j\omega L_1 - j\omega C R_3 r) = I_1 \left(\frac{R_2 R_3}{R_4} + \frac{j\omega C R_2 R_3 r}{R_4} + j\omega C R_3 R_2 \right).$$

$$\text{Equating the real and the imaginary parts : } R_1 = \frac{R_2 R_3}{R_4} - r_1 \quad \dots(16'26)$$

$$\text{and } L_1 = C \frac{R_3}{R_4} [r(R_4 + R_3) + R_2 R_4] \quad \dots(16'27)$$

An examination of balance equations reveals that to obtain easy convergence of balance, alternate adjustments of r_1 and r should be done as they appear in only one of the two balance equations.

Advantages

1. In case adjustments are carried out by manipulating control over r_1 and r , they become independent of each other. This is a marked superiority over sliding balance conditions met with low Q coils when measuring with Maxwell's bridge. A study of convergence conditions would reveal that it is much easier to obtain balance in the case of Anderson's bridge than in Maxwell's bridge for low Q -coils.

2. A fixed capacitor can be used instead of a variable capacitor as in the case of Maxwell's bridge.

3. This bridge may be used for accurate determination of capacitance in terms of inductance.

Disadvantages

1. The Anderson's bridge is more complex than its prototype Maxwell's bridge. The Anderson's bridge has more parts and is more complicated to set up and manipulate. The balance equations are not simple and in fact are much tedious.

2. An additional junction point increases the difficulty of shielding the bridge.

Considering the above complications of the Anderson's bridge, in all the cases where a variable capacitor is permissible the more simple Maxwell's bridge is used instead of Anderson's bridge.

16.9. Owen's Bridge. This bridge may be used for measurement of an inductance in terms of

capacitance. Fig. 16.7 shows the connections and phasor diagrams, for, this bridge, under balance conditions :

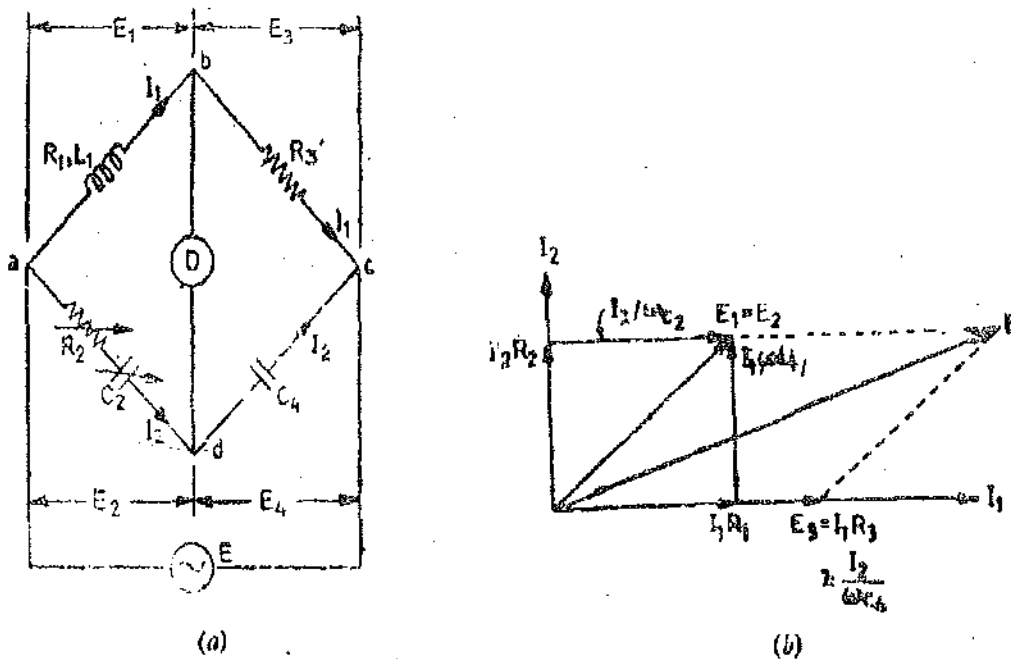

Fig. 16.7. Owen's Bridge.

Let L_1 = unknown self-inductance of resistance R_1 ,
 R_2 = variable non-inductive resistance, R_3 = fixed non-inductive resistance,
 C_2 = variable standard capacitor, and C_4 = fixed standard capacitor.

At balance, $(R_1 + j\omega L_1) \left(\frac{1}{j\omega C_4} \right) = \left(R_2 + \frac{1}{j\omega C_2} \right) R_3$.

Separating the real and imaginary terms, we obtain : $L_1 = R_2 R_3 C_4$(16.28)

and $R_1 = R_3 \frac{C_4}{C_2}$(16.29)

Advantages

1. Examining the equations for balance, we find that we obtain two independent equations in case C_2 and R_2 are made variable. Since R_2 and C_2 , the variable elements, are in the same arm, convergence to balance conditions is much easier.
2. The balance equations are quite simple and do not contain any frequency component.
3. The bridge can be used over a wide range of measurement of inductances.

Disadvantages

1. This bridge requires a variable capacitor which is an expensive item and also its accuracy is about 1 percent.
2. The value of capacitance C_2 tends to become rather large when measuring high Q coils.

16.10. Measurements of Incremental Inductance. The magnetic flux linking an iron-cored coil is not in direct proportion to the current flowing in the coil, but varies in a manner usually indicated by a magnetization curve. The flux usually increases fairly rapidly when the current build-up process first begins. However, the flux increment corresponding to a particular size of current increment becomes smaller with continual increase of current as the core approaches the condition of magnetic "saturation". An induced voltage in a coil depends on a change of flux and hence becomes smaller for a given current change at higher value of current.

The basic expression for induced voltage in terms of a changing flux is usually replaced, for

purposes of circuit study, by the "coefficient of self-inductance," multiplied by the rate of change of current. The new concept must be examined with care when applied to the case of an iron-cored coil. In terms of flux a change, the induced voltage is $e = -N \frac{d\phi}{dt}$

In terms of inductance, $e = -L \frac{di}{dt}$, where L = coefficient of self-inductance.

Comparison of the two expressions gives $L = N \frac{d\phi}{di}$

which helps to explain the nature of this quantity. Inductance may be represented by the slope of the ϕ - i curve, or magnetization curve, of a reactor. For an air-cored coil there is a linear relationship between flux and current and, accordingly, L is a constant. An iron-cored coil does not have a linear flux-current relationship, and L has different values, depending on the portion of the magnetization curve being used and on the manner of defining L . That is, for some purpose we may be interested in the average inductance, represented by the slope of a line from the origin to a particular point on the ϕ - i curve. For other purposes we are concerned with small variations in the neighbourhood of a point on the curve (for very small variations, L equals N times the slope of the curve at the point in question). It is thus evident that the coefficient of self-inductance is ambiguous for iron-cored coils unless the conditions are carefully defined.

Many iron-cored coils are used as filter reactors in rectifier circuits and in other applications in which a combination of a d.c. component and a superposed a.c. are encountered. The inductance of the reactor to the a.c. in such a case may vary over a wide range, depending on the magnitude of the d.c. term. An air gap in the magnetic core tends to straighten the ϕ - i curve, and make L more nearly constant. An iron-cored coil without an air gap gives an extreme variation of L if the d.c. component becomes high enough to produce a considerable degree of saturation.

The d.c. component of the current fixes the operating point around which changes occur on account of the alternating current. The incremental inductance at this point may be defined as turns time the slope of ϕ - i curve.

$$\therefore \text{Incremental inductance } L = N \frac{d\phi}{di} = N \frac{\Delta\phi}{\Delta i}$$

Similarly incremental permeability may be defined as the slope of the B-H curve at the operating point.

$$\text{Incremental permeability } \mu = \frac{dB}{dH} = \frac{\Delta B}{\Delta H}$$

The magnitude of the a.c. component also has an effect on the apparent inductance of the reactor, though usually not to so great an extent as the d.c. component in the common type of reactor application. To make inductance measurements on an iron-cored coil definite, the data should include the amount of d.c. present, and the frequency and magnitude of the a.c.

The nonlinear character of the flux-current curve enters in the measurement problem in another way, by producing distortion of the current and voltage waveforms. That is, a sinusoidal voltage does not produce a sinusoidal current, or vice-versa, in an iron-cored coil. Even though the applied bridge voltage is sinusoidal, the detector voltage is distorted and hence may be analyzed by Fourier method into the fundamental frequency component plus harmonics. The harmonics cause difficulties in the balancing process if the detector consists of an amplifier, a tuned circuit can be incorporated in it to pass the fundamental frequency and suppress the harmonics. The situation is a little more difficult when a telephone head set is used, but a person can train himself to listen for the null point of the fundamental frequency and disregard the harmonics. Due to the difficulties of defining inductance in the first place, and of determining balance in the second place, we cannot expect to measure parameters an iron-cored coil with the same precision as those of an air-cored coil. Fortunately, in most uses of the iron-cored coils, as in filter chokes, a low degree of accuracy is sufficient.

Many bridge circuits can be modified to permit the simultaneous application of d.c. and a.c. to the reactor. One thing that must be kept in mind in arranging the circuit is the fact that the amount of d.c. specified for the test reactor must also pass through one of the bridge arms, and care must be taken not to overheat the precision resistor.

The incremental inductance can be measured with an Owen's bridge. The original circuit, however, has to be modified in order that the coil under measurement is fed from both d.c. and a.c. This circuit is shown in Fig. 16'8.

The coil is fed from a.c. and d.c. sources in parallel. A blocking capacitor C , is used to block direct current from entering the a.c. source. A high inductance L , is used to block alternating current to enter d.c. source. Any direct current must not affect the balance and this condition is automatically satisfied in Owen's bridge because capacitors C_2 and C_4 block any d.c. current flowing through the detector.

As has been mentioned earlier, it is necessary to know the magnetization conditions under which the coil is being worked. The d.c. component of current is measured by a moving coil ammeter A connected in the d.c. supply circuit. The a.c. component of current may be easily obtained from the reading of a valve voltmeter (not sensitive to d.c.) connected across the known resistance R_3 . The value of current calculated from this reading is a.c. current through R_3 , but this is also, at balance, the a.c. current through the coil.

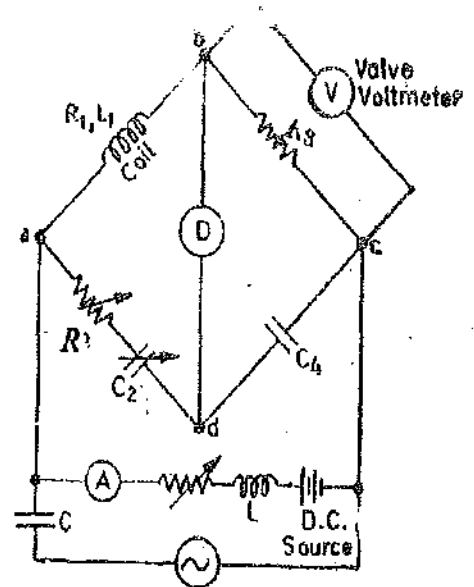

Fig. 16'8. Owen's bridge for measurement of incremental inductance.

At balance, incremental inductance $L_1 = R_2 R_3 C_4$... (16'30)

Now, inductance $L_1 = \frac{N^2}{l \mu A}$

∴ Incremental permeability $\mu = \frac{L_1 l}{N^2 A}$... (16'31)

where

N = number of turns,

A = area of flux path,

l = length of flux path,

and L_1 = incremental inductance.

MEASUREMENT OF CAPACITANCE

16'11. De Santy's Bridge. The bridge is the simplest of comparing two capacitances. The connections and the phasor diagram of this bridge are shown in Fig. 16'9.

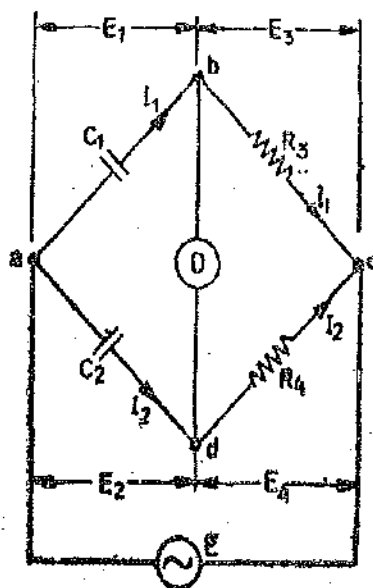

(a)

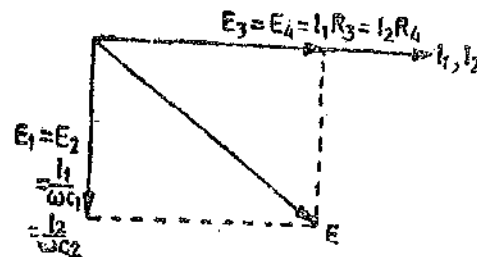

(b)

Fig. 16'9. De Santy's Bridge.

Let C_1 = capacitor whose capacitance is to be measured,

C_2 = a standard capacitor,

and R_3, R_4 = non-inductive resistors.

At balance,
$$\left(\frac{1}{j\omega C_1}\right) R_4 = \left(\frac{1}{j\omega C_2}\right) R_3$$

or
$$C_1 = C_2 \cdot \frac{R_4}{R_3} \quad \dots(16'32)$$

The balance can be obtained by varying either R_3 or R_4 . The advantage of this bridge is its simplicity. But this advantage is nullified by the fact that it is impossible to obtain balance if both the capacitors are not free from dielectric loss. Thus with this method only air capacitors can be compared.

In order to make measurements on imperfect capacitors (i.e., capacitors having dielectric loss), the bridge is modified as shown in Fig. 16'10. This modification is due to Grover.

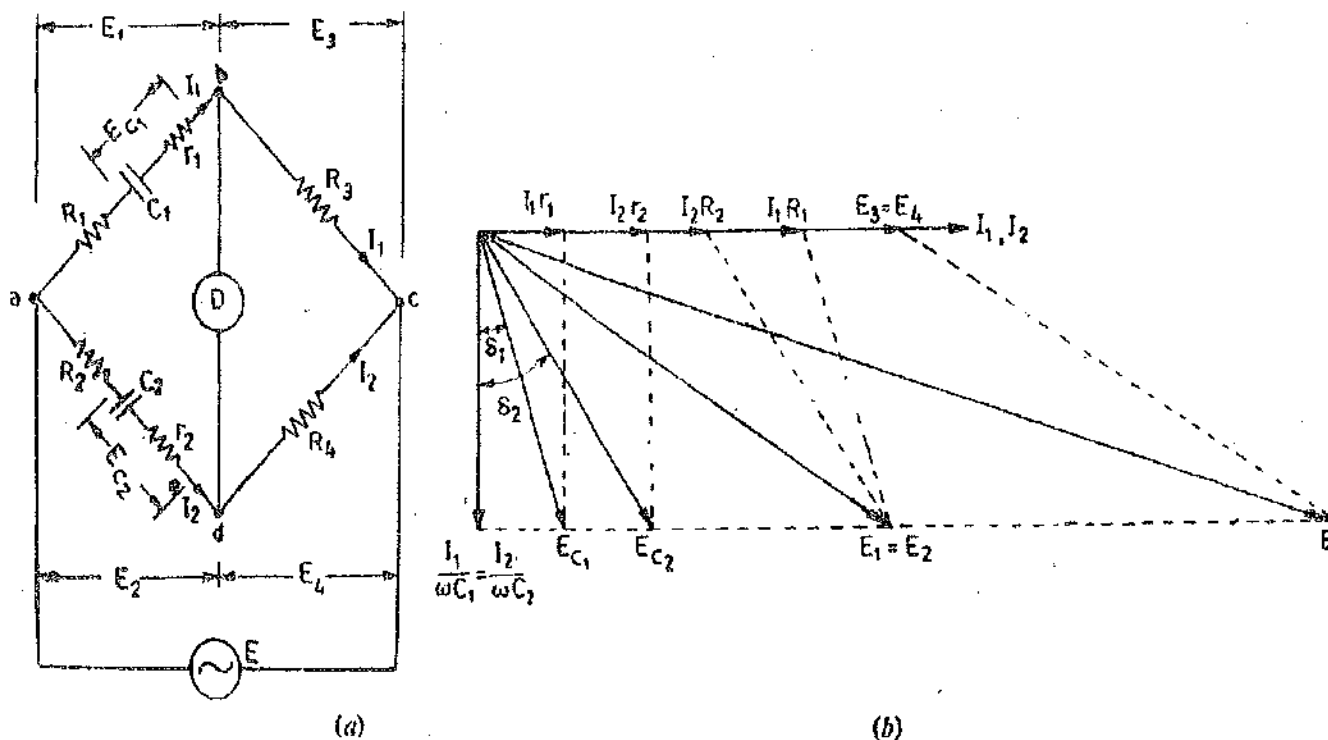

Fig. 16'10. Modified De Sauty's Bridge.

Resistors R_1 and R_2 are connected in series with C_1 and C_2 respectively. r_1 and r_2 are small resistances representing the loss component of the two capacitors.

At balance
$$\left(R_1 + r_1 + \frac{1}{j\omega C_1}\right) R_4 = \left(R_2 + r_2 + \frac{1}{j\omega C_2}\right) R_3.$$

From which we have:
$$\frac{C_1}{C_2} = \frac{R_2 + r_2}{R_1 + r_1} = \frac{R_4}{R_3} \quad \dots(16'33)$$

The balance may be obtained by variation of resistances R_1, R_2, R_3, R_4 .

Fig. 16'10 (b) shows the phasor diagram of the bridge under balance conditions. The angles δ_1 and δ_2 are the phase angles of capacitors C_1 and C_2 respectively.

Dissipation factor for the capacitors are :

$$D_1 = \tan \delta_1 = \omega C_1 r_1 \quad \text{and} \quad D_2 = \tan \delta_2 = \omega C_2 r_2$$

From Eqn. 16'33, we have
$$\frac{C_1}{C_2} = \frac{R_2 + r_2}{R_1 + r_1}$$

or
$$C_2 r_2 - C_1 r_1 = C_1 R_1 - C_2 R_2 \quad \text{or} \quad \omega C_2 r_2 - \omega C_1 r_1 = \omega(C_1 R_1 - C_2 R_2)$$

$$\therefore D_2 - D_1 = \omega(C_1 R_1 - C_2 R_2)$$

But $\frac{C_1}{C_2} = \frac{R_4}{R_3} \therefore C_1 = C_2 \cdot \frac{R_4}{R_3}$

Hence $D_2 - D_1 = \omega C_2 \left(\frac{R_1 R_4}{R_3} - R_2 \right) \dots (16.34)$

Therefore, if the dissipation factor of one of the capacitors is known, the dissipation factor for the other can be determined.

This method does not give accurate results for dissipation factor since its value depends difference of quantities $R_1 R_4 / R_3$ and R_2 . These quantities are moderately large and their difference is very small and since this difference cannot be known with a high degree accuracy the dissipation factor cannot be determined accurately.

16.12. Schering Bridge. The connections and phasor diagram of the bridge under balance conditions are shown in Fig. 16.11.

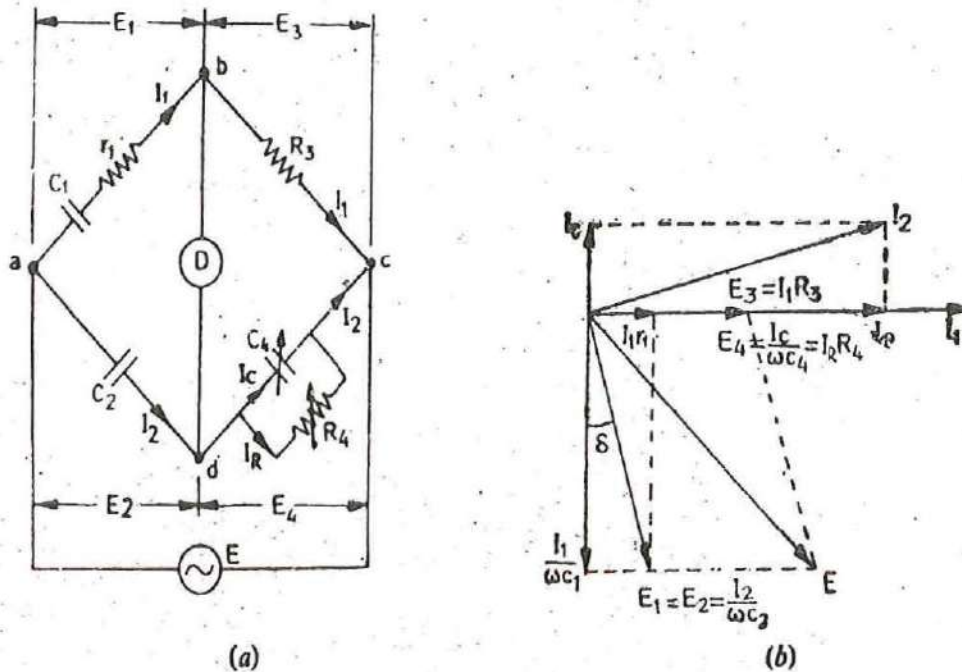

Fig. 16.11. Low voltage Schering Bridge.

Let C_1 = capacitor whose capacitance is to be determined,

r_1 = a series resistance representing the loss in the capacitor C_1 ,

C_2 = a standard capacitor. This capacitor is either an air or a gas capacitor and hence is loss free. However, if necessary, a correction may be made for the loss angle of this capacitor.

R_3 = a non-inductive resistance,

C_4 = a variable capacitor,

and R_4 = a variable non-inductive resistance in parallel with variable capacitor C_4 .

At balance, $\left(r_1 + \frac{1}{j\omega C_1} \right) \left(\frac{R_4}{1 + j\omega C_4 R_4} \right) = \frac{1}{j\omega C_2} \cdot R_3$

or $\left(r_1 + \frac{1}{j\omega C_1} \right) R_4 = \frac{R_3}{j\omega C_2} (1 + j\omega C_4 R_4)$

or
$$r_1 R_4 - \frac{jR_4}{\omega C_1} = -j \frac{R_3}{\omega C_2} + \frac{R_3 R_4 C_4}{C_2}$$

Equating the real and imaginary terms, we obtain
$$r_1 = \frac{C_4}{C_2} R_3 \quad \dots(16.35)$$

and
$$C_1 = \frac{R_4}{R_3} C_2 \quad \dots(16.36)$$

Two independent balance equations are obtained if C_4 and R_4 are chosen as the variable elements.

Dissipation factor $D_1 = \tan \phi = \omega C_1 r_1 = \omega \frac{R_4}{R_3} C_2 \cdot \frac{C_4}{C_2} R_3 = \omega C_4 R_4 \quad \dots(16.37)$

Therefore values of capacitance C_1 , and its dissipation factor are obtained from the values of bridge elements at balance.

Permanently set up Schering bridges are sometimes arranged so that balancing is done by adjustment of R_3 and C_4 with C_2 and R_4 remaining fixed. Since R_3 appears in both the balance equations and therefore there is some difficulty in obtaining balance but it has certain advantages as explained below :

The equation for capacitance is $C_1 = \frac{R_4}{R_3} C_2$ and since R_4 and C_2 are fixed, the dial of resistor R_3 may be calibrated to read the capacitance directly.

Dissipation factor $D_1 = \omega C_4 R_4$ and in case the frequency is fixed the dial of capacitor C_4 can be calibrated to read the dissipation factor directly.

Let us say that the working frequency is 50 Hz and the value of R_4 is kept fixed at 3,180 Ω .

\therefore Dissipation factor $D_1 = 2\pi \times 50 \times 3180 \times C_4 = C_4 \times 10^6$.

Since C_4 is a variable decade capacitance box, its setting in μF directly gives the value of the dissipation factor.

It should, however, be understood that the calibration for dissipation factor holds good for one particular frequency, but may be used at another frequency if correction is made by multiplying by the ratio of frequencies.

16.13. High Voltage Schering Bridge. Schering bridge is widely used for capacitance and dissipation factor measurements. In fact Schering bridge is one of the most important of the a.c. bridges. It is extensively used in the measurement of capacitance in general, and in particular in the measurement of the properties of insulators, condenser bushings, insulating oil and other insulating materials. This bridge is particularly suitable for small capacitances, and is then usually supplied from a high frequency or a high voltage source. The measurements done on small capacitances suffer from many disadvantages if carried out at low voltages. High voltage schering bridge is certainly preferable for such measurements.

The special features of a high voltage Schering bridge shown in Fig. 16.12, are explained below :

1. The high voltage supply is obtained from a transformer usually at 50 Hz. The detector, in this case, is a vibration galvanometer.

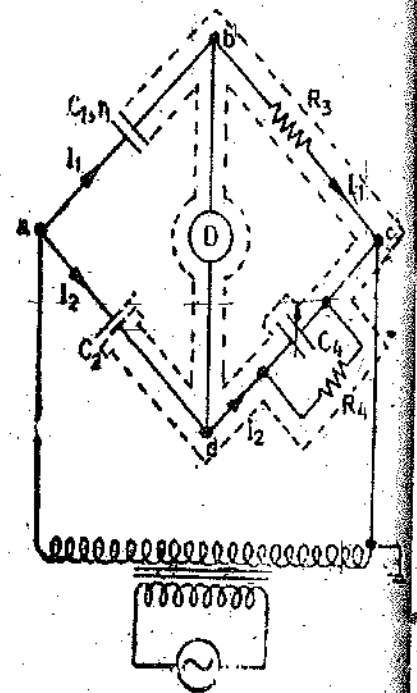

Fig. 16.12. High voltage Schering Bridge.

2. Arms ab and ad each contain only a capacitor and these capacitors are designed for high voltage work. The impedance of these two arms are very high in comparison with the other arms, bc and dc . Thus the major portion of potential drop will be in the arms ab and ad and very little voltage drop is there across the arms bc and dc . The point c is earthed. Such is the large magnitude of impedances in arms ab and ad , that even if a voltage as high as 100 kV is applied to the bridge, the voltage across arms bc and dc is a few volt above earth. This is certainly a great advantage as the controls are located in arms bc and dc and for the safety of the operator, these controls should be and are at low potential with respect to earth. For the same reason the detector is also at a low potential.

3. It is necessary to prevent dangerous high voltages appearing across arms bc and dc in the case of breakdown of either of the high voltage capacitors. This is done by connecting a spark gap, (set to breakdown at about 100 V) across each of the arms bc and dc .

4. The impedances of arms ab and ad are large and therefore the current drawn from the source is small and hence the power loss is quite small. But this small value of current also necessitates the use of a sensitive detector.

5. The fixed standard capacitor, C_2 , has either air or compressed gas as dielectric. The dissipation factor of a dry and clean gas is sensibly zero, loss in the insulating supports cannot be avoided. This loss, however, can be prevented from influencing the measurements by the use of a guard ring from which both electrodes of the capacitor are supported. With this arrangement the current through the high voltage supports passes direct to earth, and as the potential difference between low voltage electrode and the guard ring is very small, the insulation of the low voltage electrode has a negligible effect. For some general applications, mica capacitors are used and in such cases, the dissipation factor of the capacitor must be accurately known.

6. Earthed screens are provided in order to avoid errors caused due to inter-capacitance between high and low arms of the bridge. Instead of earthing one point on the circuit as shown in Fig. 16.12, the earth capacitance effect on the galvanometer and leads is eliminated by means of a "Wagner earth device" (described later in this chapter).

16.14. Measurement of Relative Permittivity with Schering Bridge. Schering bridge is very useful for the measurement of relative permittivity of dielectric materials. The determination of relative permittivity involves the measurement of capacitance of a small capacitor with the specimen as dielectric. The capacitor with specimen as dielectric is formed by using either a parallel plate or a concentric cylinder configuration for the electrodes. Guard circuits are used in order to make the plate area definite.

Many different techniques are used, both in the type of specimen capacitor used and in the measuring circuit. The normal arrangement for solid materials is to use a disc specimen with metal electrodes. The electrodes may consist of thin metal foil attached to the specimen by petroleum jelly, or thin films of silver or aluminium applied by evaporation (both these arrangements normally have solid metal backing electrodes), or mercury. Mercury electrodes are obtained by floating (or supporting) the specimen on the surface of a mercury pool, the upper electrodes consisting of a smaller mercury pool held in place by a metal containing ring. Liquid specimens fill the space between the concentric cylindrical electrodes of a test cell.

The relative permittivity is calculated from the measured value of capacitance and the dimensions of the electrodes. For a parallel plate arrangement, relative permittivity $\epsilon_r = \frac{C_s d}{\epsilon_0 A}$... (16.38)

where C_s = measured value of capacitance with specimen as dielectric,

d = spacing between electrodes,

A = effective area of electrodes,

and ϵ_0 = permittivity of free space.

A method which avoids the necessity for close contact between electrodes and specimen uses a pair of solid electrodes (one with a guard ring) between which the specimen (thinner than the space between electrodes) is slipped. The capacitance of the arrangement is measured, the specimen is then removed, and the spacing between the electrodes is adjusted, by means of micrometer adjustments, until the capacitance is the same as before. The relative permittivity of the specimen can be calculated from the thickness of the specimen and the alteration in electrode spacing.

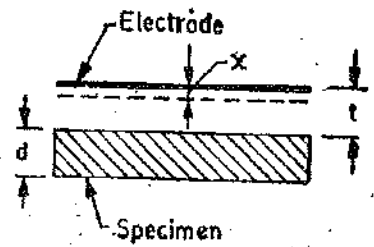

Fig. 16'13. Measurement of relative permittivity.

Let C = capacitance with specimen between electrodes,
 A = area of electrodes,

d = thickness of specimen,

t = gap between specimen and electrode,

and x = reduction in separation between the two measurements.

These dimensions are shown in Fig. 16'13.

Let C_s = capacitance of specimen,

C_0 = capacitance due to space between specimen and electrode,

and C = effective capacitance of C_s and C_0 in series.

$$C = \frac{C_s C_0}{C_s + C_0} = \frac{(\epsilon_r \epsilon_0 A/d) \cdot (\epsilon_0 A/t)}{(\epsilon_r \epsilon_0 A/d) + (\epsilon_0 A/t)} = \frac{\epsilon_r \epsilon_0 A}{\epsilon_r t + d}$$

When the specimen is removed and the spacing readjusted to give the same capacitance, the expression for capacitance is

$$C = \frac{\epsilon_0 A}{t + d - x} \quad \text{Hence} \quad \frac{\epsilon_0 A}{t + d - x} = \frac{\epsilon_r \epsilon_0 A}{\epsilon_r t + d}$$

$$\epsilon_r = \frac{d}{d - x} \quad \dots(16'39)$$

MEASUREMENT OF MUTUAL INDUCTANCE

16'15. Uses of Mutual Inductance in Bridge Circuits. Mutual inductance has been used in a great number of bridges for a variety of purposes. Known mutual inductances are used in some circuits for the measurement of unknown mutual inductance. Variable standard mutual inductances have been used as components in bridges for the measurement of self-inductances, capacitance, and frequency. Many such bridges are found in literature, but some of the circuits represent minor modifications of other bridges; that is, changes to achieve greater accuracy or convenience for a particular type of measurement, or a special range of unknown quantities.

We shall study only a small number of these circuits. Applications to capacitance and self-inductance determinations are of secondary interest because methods using a capacitance standard are generally more convenient and accurate for these measurements than a mutual inductor and they (capacitors) are also cheaper, compact, and more generally available. The mutual inductance circuits may have particular merit in some cases, but this enters the field of special research rather than of general measurements, so we shall not attempt to go into much detail. Much reference material is available on the subject.

The derivation of the balance equations requires a different method when we have mutual coupling between the arms. It is necessary to write equations for the voltages around the loops and then to make solution for the unknown quantities.

16'16. Mutual Inductance Measured as Self-Inductance. If the terminals of the two coils whose mutual inductance is to be measured are available for series connection, measurement may be made by one of the self inductance bridges considered earlier. If the connections are made so that the magnetic fields of the two coils are additive [Fig. 16'14 (a)]. The effective inductance of the two coils in series is

$$L_{e1} = L_1 + L_2 + 2M \quad \dots(16'40)$$

If the connections of one coil are reversed [Fig. 16'14 (b)].

$$L_{e2} = L_1 + L_2 - 2M \quad \dots(16'41)$$

Thus from Eqns. 16'40 and 16'41, we get

$$\text{Mutual inductance } M = \frac{1}{4}(L_{e1} - L_{e2}) \quad \dots(16'42)$$

Hence mutual inductance is obtained as one-fourth of difference of self inductance measured with series additive and series subtractive connections. This method is of advantage only when fairly high coupling between the two coils is obtained otherwise it results in poor accuracy due to nearly equal terms of Eqn. 16'42.

16'17. Heaviside Mutual Inductance Bridge. This Bridge (shown in Fig. 16'15) measures mutual inductance in terms of a known self-inductance. The same bridge, slightly modified, was used by Campbell to measure a self-inductance in terms of a known mutual inductance.

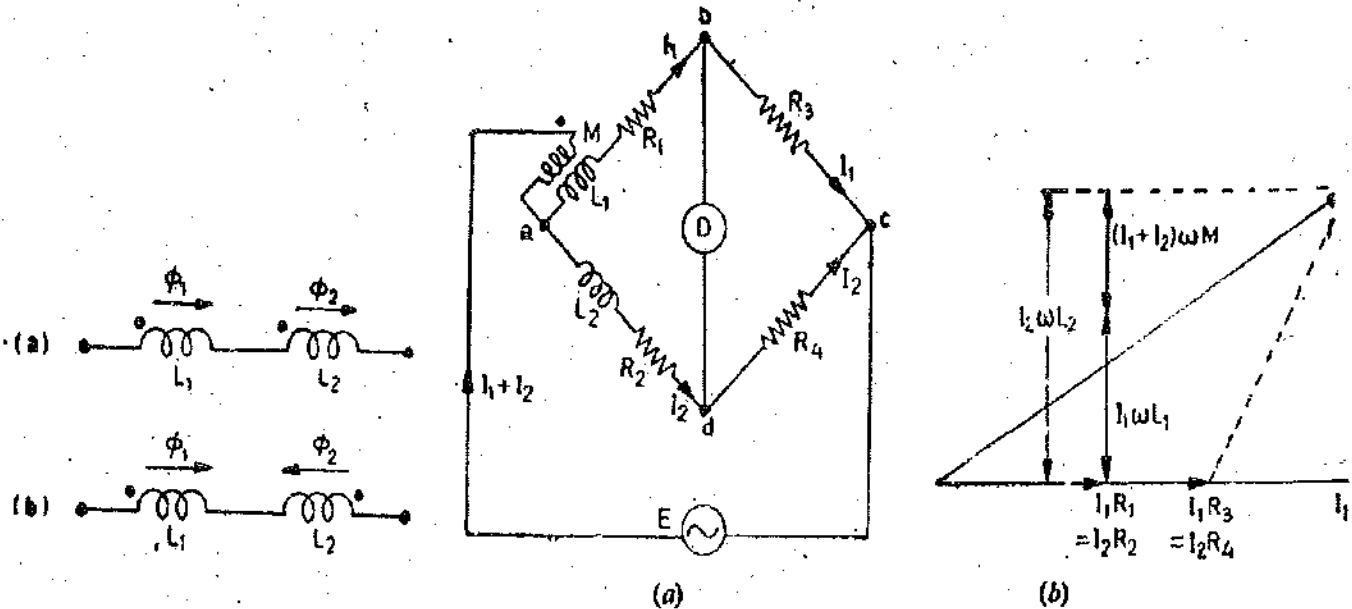

Fig. 16'14. Positive and negative couplings for mutual inductors.

Fig. 16'15. Heaviside mutual inductance Bridge.

Let

M = unknown mutual inductance,

L_1 = self-inductance of secondary of mutual inductance,

L_2 = known self inductance,

and R_1, R_2, R_3, R_4 = non-inductive resistors.

At balance voltage drop between b and c must equal the voltage drop between d and c . Also the voltage drop across $a-b-c$ must equal the voltage drop across $a-d-c$. Thus we have the following equations at balance.

$$I_1 R_3 = I_2 R_4$$

and

$$(I_1 + I_2)(j\omega M) + I_1(R_1 + R_3 + j\omega L_1) = I_2(R_2 + R_4 + j\omega L_2).$$

$$\therefore I_2 \left(\frac{R_4}{R_3} + 1 \right) j\omega M + I_2 \frac{R_4}{R_3} (R_1 + R_3 + j\omega L_1) = I_2 (R_2 + R_4 + j\omega L_2)$$

or
$$j\omega M \left(\frac{R_4}{R_3} + 1 \right) + \frac{R_4}{R_3} R_1 + R_4 + j\omega L_1 \frac{R_4}{R_3} = R_2 + R_4 + j\omega L_2$$

Thus
$$R_1 R_4 = R_2 R_3 \quad \dots(16.43)$$

and
$$M = \frac{L_2 - L_1 R_4 / R_3}{R_4 / R_3 + 1} = \frac{R_3 L_2 - R_4 L_1}{R_4 + R_3} \quad \dots(16.44)$$

It is clear from Eqn. 16.44, that L_1 , the self-inductance of the secondary of the mutual inductor must be known in order that M be measured by this method.

In case $R_3 = R_4$, we get,
$$M = \frac{L_2 - L_1}{2} \quad \dots(16.45)$$

and
$$R_1 = R_2 \quad \dots(16.46)$$

This method can be used for measurement of self-inductance. Supposing L_2 is the self-inductance to be determined.

From Eqns. 16.43 and 16.44, we get

$$L_2 = \frac{M(R_3 + R_4) + R_4 L_1}{R_3} = M \left(1 + \frac{R_4}{R_3} \right) + \frac{R_4}{R_3} L_1 \quad \dots(16.47)$$

and
$$R_2 = R_1 \frac{R_4}{R_3} \quad \dots(16.48)$$

In case $R_4 = R_3$, we have

$$L_2 = 2M + L_1$$

and
$$R_2 = R_1$$

16.18. Campbell's Modification of Heaviside Bridge.

Fig. 16.16 shows a modified Heaviside bridge. This modification is due to Campbell. This is used to measure a self-inductance in terms of a mutual inductance. In this case an additional balancing coil L, R is included in arm ad in series with inductor under test. An additional resistance r is put in arm ab . Balance is obtained by varying M and r . A short circuiting switch is placed across the coil R_2, L_2 under measurement. Two sets of readings are taken one with switch being open and the other with switch being closed. Let values of M and r , be M_1 and r_1 with switch open, and M_2 , and r_2 with switch closed.

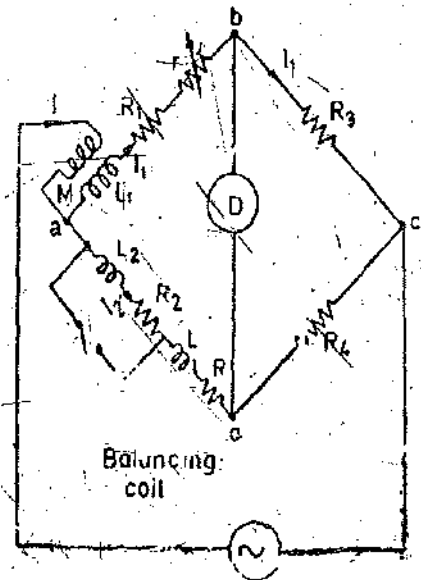

Fig. 16.16. Campbell's modification of Heaviside bridge.

∴ From Eqn. 16.47, we have :
$$L_2 + L = \frac{M_1(R_3 + R_4) + R_4 L_1}{R_3}$$

and
$$L = \frac{M_2(R_3 + R_4) + R_4 L_1}{R_3} \quad \dots L_2 = \frac{(M_1 - M_2)R_3 + R_4}{R_3} = (M_1 - M_2) \left(1 + \frac{R_4}{R_3} \right) \quad \dots(16.49)$$

From Eqn. 16.48, we can write :
$$R_2 + R = (R_1 + r_1) \frac{R_4}{R_3} \quad \text{and} \quad R = (R_1 + r_2) \frac{R_4}{R_3}$$

∴
$$R_2 = (r_1 - r_2) \frac{R_4}{R_3} \quad \dots(16.50)$$

This method is a good example of the methods adopted to eliminate the effects of leads etc.

When we have equal ratio arms $R_3 = R_4$ and therefore from Eqns. 16'49 and 16'50, we get : $L_2 = 2(M_1 - M_2)$... (16'51)

and $R_2 = r_1 - r_2$... (16'52)

16'19. Heaviside Campbell Equal Ratio Bridge. The use of balancing coil in the above method reduces the sensitivity of the bridge. Fig. 16'17 shows Heaviside Campbell equal ratio bridge. This is a better arrangement which improves sensitivity and also dispenses with the use of a balancing coil.

In this method the secondary of the mutual inductor is made up of two equal coils L , L and the primary of mutual inductance reacts with both of them. L_2, R_2 is the coil whose self-inductance and resistance is to be determined. The resistances R_3 and R_4 are made equal. Balance is obtained by varying the mutual inductance and resistance r .

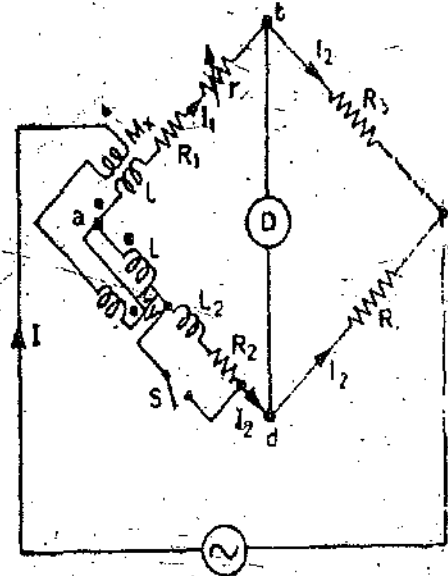

Fig. 16'17. Heaviside Campbell equal ratio bridge.

At balance, $I_1 R_3 = I_2 R_4$

but $R_3 = R_4$

and therefore $I_1 = I_2 = I/2$ as $I = I_1 + I_2$.

Writing the other equation for balance :

$$I_1(R_1 + r) + I_1 j\omega L + I_1 j\omega M_x = I_2 R_2 + I_2 j\omega(L_2 + L) - j\omega M_y$$

$$\text{or } \frac{R_1 + r}{2} + j\omega \left(\frac{L}{2} + M_x \right) = \frac{R_2}{2} + j\omega \left(\frac{L_2 + L}{2} \right) - j\omega M_y$$

Equating the real and imaginary terms

$$R_2 = R_1 + r \quad \dots (16'53)$$

$$\text{and } L_2 = 2(M_x + M_y) = 2M \quad \dots (16'54)$$

Thus the magnitude of inductance which can be measured with this method is twice the range of the mutual inductor. The values calculated above include the effects of leads etc. In order to eliminate these effects, we take two readings with switch open circuited and another with switch closed. Let M_1, r_1 be the readings of M, r with open circuit and M_2, r_2 with short circuit.

$$R_1 = r_1 - r_2 \quad \dots (16'55)$$

$$\text{and } L_1 = 2(M_1 - M_2) \quad \dots (16'56)$$

16'20. Carey Foster Bridge ; Heydweiller Bridge. This bridge was used basically by Carey Foster but was subsequently modified by Heydweiller for use on a.c. Both names are associated with the bridge and is used for two opposite purposes :

(i) It is used for measurement of capacitance in terms of a standard mutual inductance. The bridge in this case is known as Carey Foster's bridge.

(ii) It can also be used for measurement of mutual inductance in terms of a standard capacitance and is then known as Heydweiller bridge.

Fig. 16'18 shows the connection diagram for the bridge under balance conditions.

This bridge has an unusual feature, one of its arms, ad , is short circuited and therefore the potential drop across this arm is zero. In order to achieve balance, the potential drop across arm ab should also be equal to zero and for this reason negative coupling is needed for the mutual inductance.

At balance, $I_1(R_1 + j\omega L_1) - (I_1 + I_2)j\omega M = 0$

and $I_1 \left(R_3 + \frac{1}{j\omega C_3} \right) = I_1 R_4$

The solution of the above equation gives : $M = R_1 R_4 C_3$... (16'57)

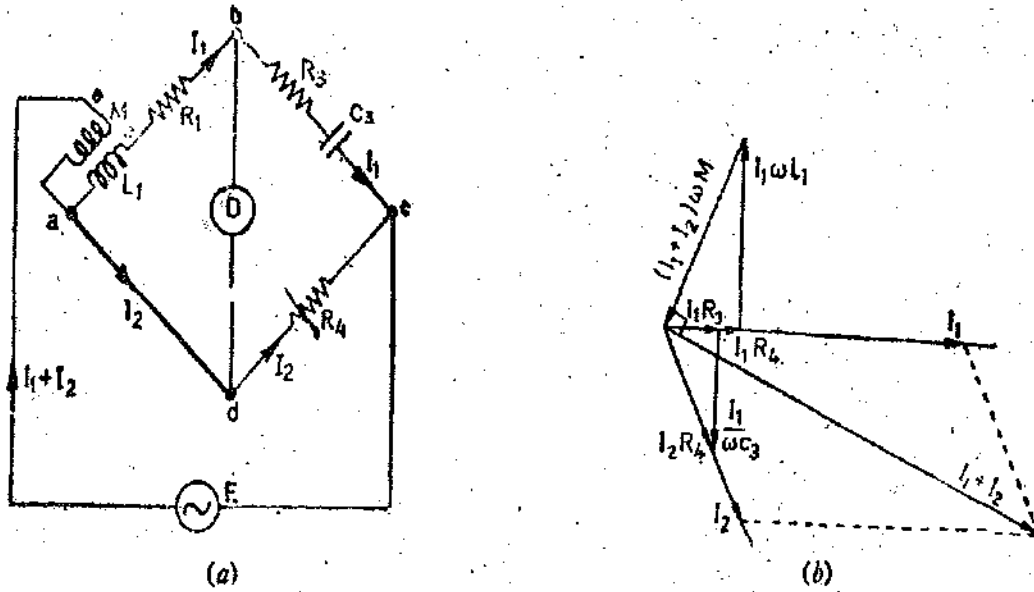

Fig. 16'18. Carey Foster (Heydweiller) Bridge.

and

$$L_1 = \frac{M(R_3 + R_4)}{R_4} = R_1 C_3 (R_3 + R_4) \quad \dots(16'58)$$

If the bridge is used for measurement of capacitance Eqns. 16'57 and 16'58 may be written as :

$$C_3 = \frac{M}{R_1 R_4} \quad \dots(16'59)$$

$$R_3 = \frac{R_4 (L_1 - M)}{M} \quad \dots(16'60)$$

In the measurement of mutual inductance with this bridge, R_3 is a separate resistance while in the measurement of capacitance R_3 is not a separate unit but represents the equivalent series resistance of the capacitor and thus can be determined in terms of the elements of the bridge.

16'21. Campbell's Bridge. This bridge measures an unknown mutual inductance in terms of a standard mutual inductance. Fig. 16'19 shows the circuit diagram for the bridge.

- Let M_1 = unknown mutual inductance,
- L_1 = self-inductance of secondary of mutual inductance M_1 ,
- M_2 = variable standard mutual inductance,
- L_2 = self-inductance of secondary of mutual inductance M_2 ,

and R_1, R_2, R_3, R_4 = non-inductive resistances.

There are two steps required in the balancing process.

1. Detector is connected between b and d . The circuit now becomes a simple self-inductance comparison bridge. The requirement for balance is :

$$\frac{L_1}{L_2} = \frac{R_1}{R_2} = \frac{R_3}{R_4} \quad \dots(16'61)$$

The bridge may be balanced by adjustment of R_3 (or R_4) and R_1 (or R_2).

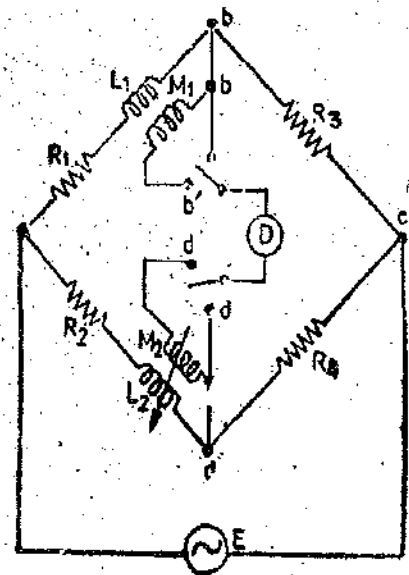

Fig. 16'19. Campbell's Bridge.

2. Detector is connected between b' and d' . Keeping adjustments as in step 1 above, the variable mutual inductance M_2 is varied to get balance. Then, $\frac{M_1}{M_2} = \frac{R_3}{R_4}$

or
$$M_1 = M_2 \frac{R_3}{R_4} \quad \dots(16'62)$$

MEASUREMENT OF FREQUENCY

Some bridges have balance equations which involve frequency directly even if the performance of individual bridge elements is independent of frequency. These bridges may be used for determination of frequency in terms of values of various bridge elements. We shall describe here the Wien's bridge, which is the most important one.

16'22. **Wien's Bridge.** The Wien's bridge is primarily known as a frequency determining bridge and is described here not only for its use as an a.c. bridge to measure frequency but also for its application in various other useful circuits. A Wien's bridge, for example, may be employed in a harmonic distortion analyzer, where it is used as notch filter, discriminating against one specific frequency. The Wien's bridge also finds applications in audio and HF oscillators as the frequency determining device.

Fig. 16'20 shows a Wien's bridge under balance conditions.

At balance
$$\left(\frac{R_1}{1 + j\omega C_1 R_1} \right) R_4 = \left(R_2 - \frac{j}{\omega C_2} \right) R_3$$

or
$$\frac{R_4}{R_3} = \frac{R_2}{R_1} + \frac{C_1}{C_2} + j \left(\omega C_1 R_2 - \frac{1}{\omega C_2 R_1} \right)$$

Equating the real and imaginary parts

$$\frac{R_4}{R_3} = \frac{R_2}{R_1} + \frac{C_1}{C_2} \quad \dots(16'63)$$

and
$$\omega C_1 R_2 - \frac{1}{\omega C_2 R_1} = 0$$
 from which
$$\omega = \frac{1}{\sqrt{R_1 R_2 C_1 C_2}}$$

and frequency
$$f = \frac{1}{2\pi \sqrt{R_1 R_2 C_1 C_2}} \quad \dots(16'64)$$

In most Wien bridges, the components are so chosen that

$$R_1 = R_2 = R \quad \text{and} \quad C_1 = C_2 = C.$$

The Eqn. 16'63 reduces to :
$$\frac{R_4}{R_3} = 2$$

and Eqn. 16'64 reduces to
$$f = \frac{1}{2\pi RC} \quad \dots(16'65)$$

Switches k_1 resistors R_1 and R_2 are mechanically linked so as to fulfil the condition $R_1 = R_2$.

As long as R_1 and C_2 are fixed capacitors equal in value and $R_4 = 2R_3$, the Wien's bridge may be used as a frequency determining device, balanced by a single control. This control may be directly calibrated in terms of frequency as is evident from Eqn. 16'65.

This bridge is suitable for measurement of frequencies from 100 Hz to 100 kHz. It is possible to obtain an accuracy of 1 to 0.5 per cent.

Because of its frequency sensitivity, the Wien's bridge may be difficult to balance unless the waveform of the applied voltage is sinusoidal. The bridge is not balanced for any harmonics present in the applied voltage, so that these harmonics will sometimes produce an output voltage masking

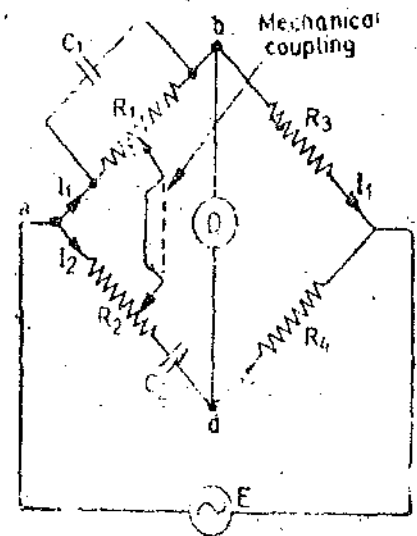

Fig. 16'20. Wien's Bridge.

the true balance point. This difficulty can be overcome by connecting a filter in series with the null detector.

A Wien's bridge may be used for measurement of capacitance also.

16'23. Universal Impedance Bridge. One of the most useful and versatile laboratory bridges is the Universal Impedance Bridge. The set up of this bridge combines several of the bridge configurations described so far into a single portable instrument. This instrument is capable of measuring both d.c. and a.c. resistance, inductance and storage factor Q factor of an inductor, capacitance and dissipation factor D of a capacitor.

The universal bridge consists of four basic bridge circuits. It has suitable a.c. and d.c. sources, a.c. and d.c. null detectors, and impedance standards. The Wheatstone bridge is used for both d.c. and a.c. resistance measurements. Capacitance and dissipation factor are determined by modified De Sauty's bridge. The Maxwell's bridge is used for medium Q inductors while Hay's bridge configuration is used for inductors having Q more than 10.

For d.c. resistance measurements a suspension type galvanometer having a sensitivity $0.5 \mu\text{A}$ per scale division is used. The null indicator for a.c. measurements is usually an electron ray tube. Terminals are provided for connection of any external null detectors. High impedance head phones may also be used as a.c. detectors.

The a.c. source of the bridge consists of an oscillator having 10 kHz as the standard frequency.

16'24. Sources of Errors in Bridge Circuits. We have assumed in our derivation of basic circuit relationships that a bridge consists of lumped impedance units connected only by the wires that are placed in the circuit for making connections. This idealized condition exists in bridge circuits to a lesser or greater extent. The idealized arrangement works fairly well if the frequency is low, if component impedances are not high and if accuracy desired is not high. But in practice there are certain factors which we have not considered yet and these complicate the behaviour of the bridge circuits considered so far.

Some of these factors are stray couplings between one bridge arm and another and from elements to ground. These stray couplings modify the balance conditions making a definite balance impossible or may lead to false balance. Thus these effects will cause incorrect values of unknown components to be attained.

Factors causing errors. The various factors causing errors in a.c. bridge circuits are listed below :

- (i) stray-conductance effects, due to imperfect insulation ;
- (ii) mutual-inductance effects, due to magnetic coupling between various components of the bridge ;
- (iii) stray-capacitance effects, due to electrostatic fields between conductor at different potentials.
- (iv) 'residuals' in components—e.g., the existence of small amount of series inductance or shunt capacitance in nominally non-reactive resistors.

16'25. Precautions and Techniques used for Reducing Errors. Errors introduced by the above effects become greater in high-frequency and high-voltage bridges, but precautions should always be taken to reduce them to a minimum. Even so, in high-accuracy work it is often necessary to determine the magnitude of some of the effects and allow for them in the bridge calculations. The more important methods of reducing bridge errors are now described.

1. Use of High-quality Components. Good-quality bridge components will normally have the advantages of high-accuracy calibration, freedom from stray conductor effects, and a minimum of residuals. Where residuals exist manufacturer supplies information giving the values of the residuals.

2. **Bridge Lay-out.** The conventional bridge-circuit diagrams in the present chapter are drawn to represent the potential distribution in the circuit; they do not indicate the best physical lay-out. In general, it is desirable that the four 'corners' of the bridge a , b , c , and d (Fig. 16'21) should be closed together. Each component is then connected to the appropriate corners by its own leads. The physical lay-out of the bridge will then be as shown in Fig. 16'21. All the leads to a single corner should be brought as nearly as possible to the same point. A pair of leads to a component should not form a large loop; if possible the leads should be co-axial. If there is more than one inductor in the bridge, leads may have to be quite long. In this manner stray mutual inductance coupling and lead self-inductances are reduced to minimum and the stray capacitances are definitely located across individual arms of bridge; they can then be measured and allowed for relatively easily.

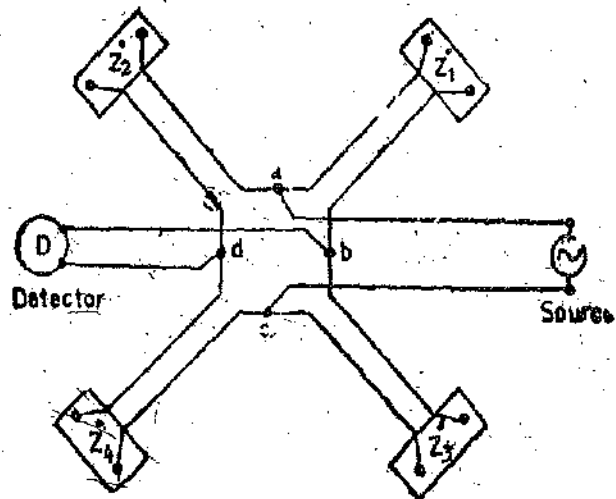

Fig. 16'21. Bridge lay-out.

3. **Sensitivity.** To obtain a high degree of accuracy e.g., 1 part in 10^4 or better, it is necessary that the bridge must be operated at sufficient sensitivity which implies that the change in voltage at the detector terminals from the balance condition should be large when the detector is considered open. The treatment is similar as with the Wheatstone bridge except that with the a.c. bridge circuit we have to consider both the magnitude and phase angle of the impedance of the bridge arms.

4. **Stray Conductance Effects.** If the insulation between various components (elements) of a bridge circuit is not good, trouble may arise because of leakage currents from one arm to another. This is specially true in the case of high impedance bridges. To avoid this various bridge components and other pieces of apparatus may be mounted on insulating stands.

5. **Eddy Current Errors.** Errors may result due to variation in the values of the standards, which may occur because of induced eddy currents in the standard resistors and inductors. In order to avoid such errors the presence of large conducting masses near the bridge network is avoided.

6. **Residual Errors.** Though the resistors used are taken as non-inductive and non-capacitive but their inductance and capacitance are never zero. Residues mean small inherent inductance or capacitance of the resistors. In precise work it becomes necessary to evaluate them in order to eliminate them or compensate errors due to these. The self-inductance is important only when the coils used are multi-turn coils and supply used is of high frequency.

7. **Frequency and Wave Form Errors.** In case of bridges whose results are independent of frequency, the supply frequency is important only from the point of view of its effects on resistance, inductance and capacitance of the apparatus under test. The presence of harmonics in the supply waveform is also important from the same point of view.

If the case of bridge network whose balance condition involves frequency the variation in supply frequency is very important both from the point of view of balance and evaluation. The waveform of the supply is also important as the bridge cannot be balanced both for fundamental and harmonics in the waveform (if any) simultaneously. If telephones are used, it will not be possible to obtain complete silence at all, but only a point of minimum sound can be achieved.

This difficulty is overcome either by employing wave filters which eliminate the unwanted harmonics from the source or by employing tuned detectors in place of telephones such as vibration galvanometers which do not respond to harmonics and respond readily only to the fundamental for which they are tuned.

16'26. **Stray Electromagnetic and Electrostatic Couplings.** We speak of electric field and magnetic field couplings as separate entities, although they cannot strictly be considered as existing

independently of each other. However, at low and moderate frequencies the two effects are sufficiently independent that we may consider each type separately. Accordingly, we refer to electro-magnetic shielding and electrostatic shielding.

A magnetic field is produced by a current flowing in a wire, and more strongly by a coil of wire. For the small currents encountered in most of the bridge circuits the magnetic effect of a single turn is negligible, but the field due to a coil may be quite important. Particularly when there are two coils in the circuit, it is important to control the magnetic coupling between them. This can be done by large spacing, by the orientation of the coils (axes at 90°), by the shape of the coils, and by shielding. A particularly good shape for this purpose is the toroidal coil, for it has practically zero external field. Coils with closed cores of magnetic material usually have small external fields and are easily shielded. Among the variable inductors, the Brooks inductometer has a rather limited external field, due to two neighbouring sets of coils connected for opposite directions of the magnetic field.

Magnetic shielding may be accomplished by one or more shells of high permeability magnetic material surrounding the part to be shielded. Multiple shells can be made to give very complete shielding. Alternating magnetic fields may also be screened by interposing highly conducting metal sheets such as copper or aluminium in the path of the magnetic flux. The eddy currents induced in the sheet give a counter mmf that tends to cancel the magnetic field beyond the sheet. This form of shielding becomes increasingly effective at higher frequencies. The shield cans used around coils in radio sets are examples of this type of shielding.

The major problem in most bridges is control of electric fields, that is, of capacitance effects between bridge components, and from components to ground. These effects can be minimized by wide separation of the parts, but while it is desirable to keep parts with large voltage difference well separated, it is not practicable to depend on this method entirely because it makes the bridge too bulky and also gives long leads (with inductance and capacitance) to join the parts. The effective way to control capacitances is to enclose bridge components in conducting shields connected to place the capacitance where it does not harm.

16.27. Shielding of Bridge Elements. Capacitances between the bridge elements and between the elements and ground affect the accuracy of a-c bridge measurements. An effective way of controlling these capacitances consists of enclosing the element in a *shield*, thereby placing the capacitance at a position in the circuit where it can do no harm. Fig. 16.22 shows control of stray capacitance in resistors is accomplished by shielding. The stray capacitance across the resistor and from each end of the resistor to ground is shown by the dashed portions of Fig. 16.22 (a). A grounded shield, which surrounds the resistor and is connected to one terminal only—[see Fig. 16.22 (b)]

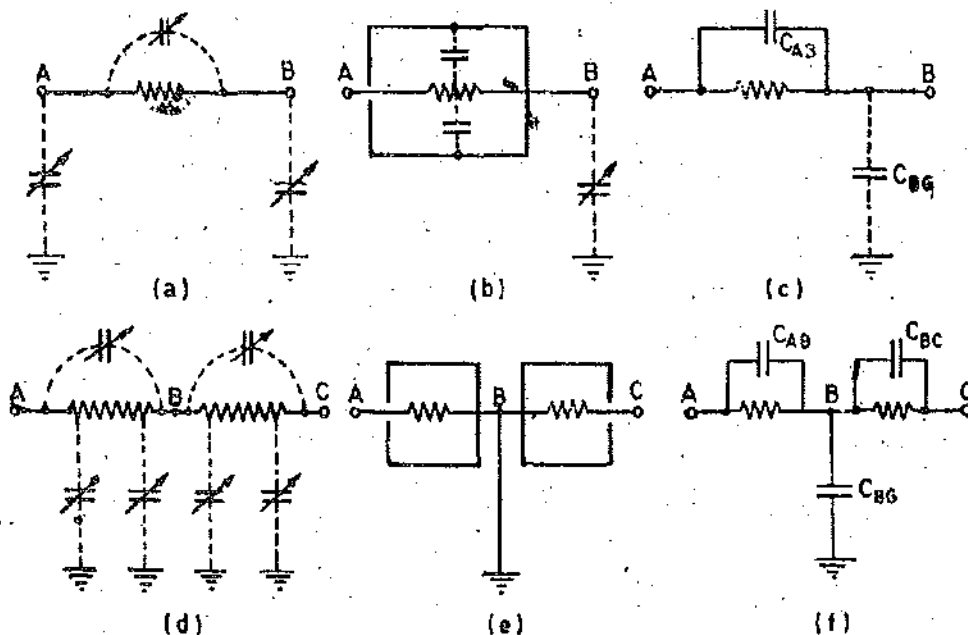

Fig. 16.22. The shielding of resistors to reduce the effect of stray capacitances.

effectively places the stray capacitance between that terminal and ground. There is still capacitance between resistor and shield, but this capacitance is of definite value and does not change. The equivalent circuit of the resistor with its surrounding shield is shown in Fig. 16'22 (c) and shows C_{AB} between the resistor terminals and C_{B0} from terminals B to ground.

Two resistors in series are often found in a bridge configuration. In this case, each resistor is shielded and the shields are connected to the common point between the resistors, as indicated in Fig. 16'22 (d). This point is then grounded and results in the equivalent circuit of Fig. 16'22 (f). C_{AB} and C_{B0} represent the capacitances within the shield, which are fixed in value, and there is the capacitance from the junction of the two resistors to ground. Notice that the stray capacitances are now concentrated at the terminals of the resistors. This means that for a resistive bridge circuit, the four corners of the bridge exhibit stray capacitance to ground, but there is no longer any stray capacitance between the bridge elements themselves. Of course, the resistors are no longer purely resistive, having the shunting capacitance within the shield across them, but these capacitances are fixed in value and the bridge can therefore be balanced without any problem.

If both terminals of a capacitor are insulated from ground, we have the condition shown in Fig. 16'23 (a), where C_{A0} and C_{B0} represent the stray capacitances to ground. The equivalent circuit is shown in Fig. 16'23 (b), and we see that we have a delta connection of three capacitors, sometimes called a *three-terminal capacitor*. When the capacitance is surrounded by a shield, which is connected to ground, we have the situation as shown in Fig. 16'23 (c). The equivalent circuit of this arrangement is shown in Fig. 16'23 (d) and we have again a delta connection of three capacitors. In this case, however, C_{AS} and C_{BS} are definite in amount and do not change owing to external effects. When the shield is connected to terminal B of the capacitor, the capacitance from B to shield is short-circuited and the capacitance from A to shield is added to the main capacitance C_{AB} , as shown in Fig. 16'23 (e). If point B may be grounded, the capacitance from shield to ground is short-circuited and we have a two-terminal capacitor, as shown in the equivalent circuit of Fig. 16'23 (f).

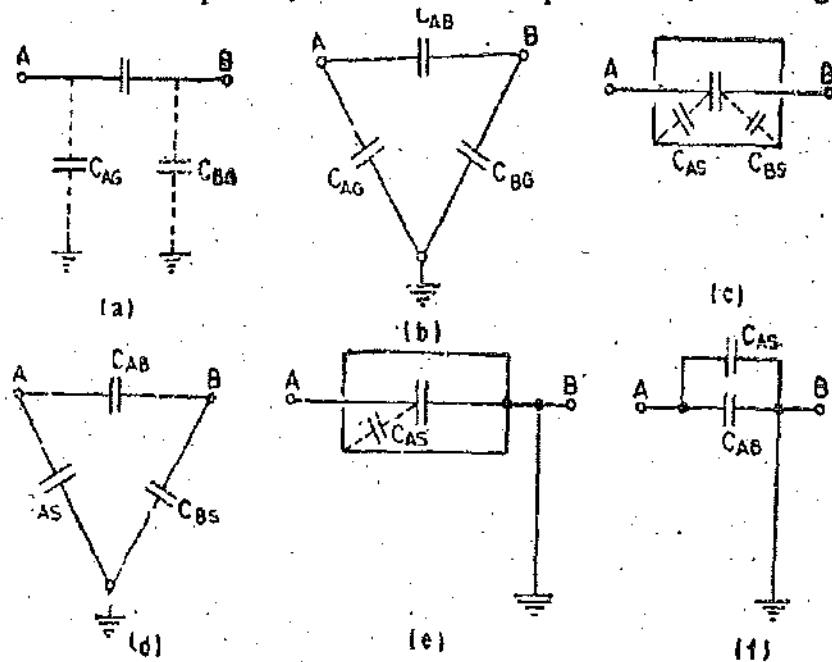

Fig. 16-23. Stray capacitances to capacitors, illustrating the effect of shielding and the resultant equivalent circuits.

Fig. 16'24(a) shows an interesting application of shielding and is used in the testing of samples of insulating materials in sheet form. A metal foil (A) is connected to one side of the sample of insulating material. The opposite side of the sample has a circular piece of metal foil (B) attached to it, which is surrounded by a guard-ring electrode, also consisting of metal foil. The guarding insures uniform capacitance between it and the centre foil. The equivalent circuit of this arrangement is a *three-terminal capacitance*, shown in Fig. 16'24 (b). It is desired to eliminate the effects of the guard-ring capacitances in the bridge circuit and to measure only the capacitance C_{AB} of the insulating

material. The bridge should therefore be so arranged that the guard-ring has the same potential as the upper foil (B).

Before discussing measurement of a three-terminal capacitance, consider the effects of stray capacitances of a bridge circuit in general. Fig. 16'25 shows stray capacitances existing in a bridge circuit. Capacitance C_1 is connected from point a to ground through the primary winding of the output transformer of the oscillator. Capacitor C_2 represents the capacitance from the top corner of the bridge to ground. These two capacitors shunt the bridge input but have no effect on the balance of the bridge. Capacitor C_3 shunts the bridge capacitance, C_{cd} , and stray capacitance C_4

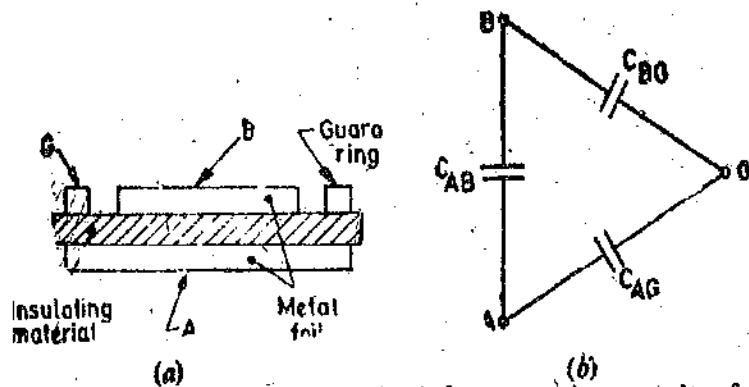

Fig. 16'24. Use of a guard circuit for measuring samples of insulating material. a) Placement of the guard ring. (b) Equivalent circuit showing the fixed capacitances between the contact foil and the guard ring (C_{BO} and C_{AG}).

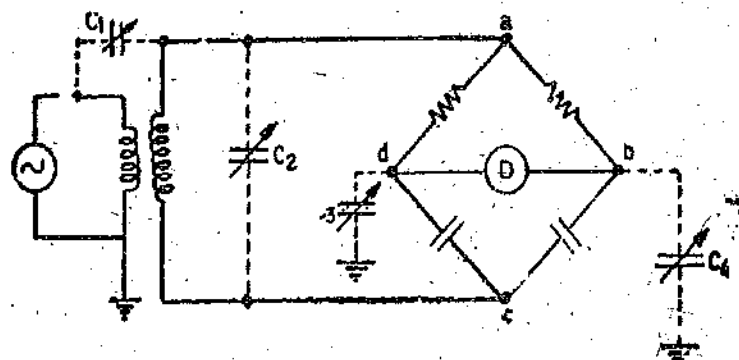
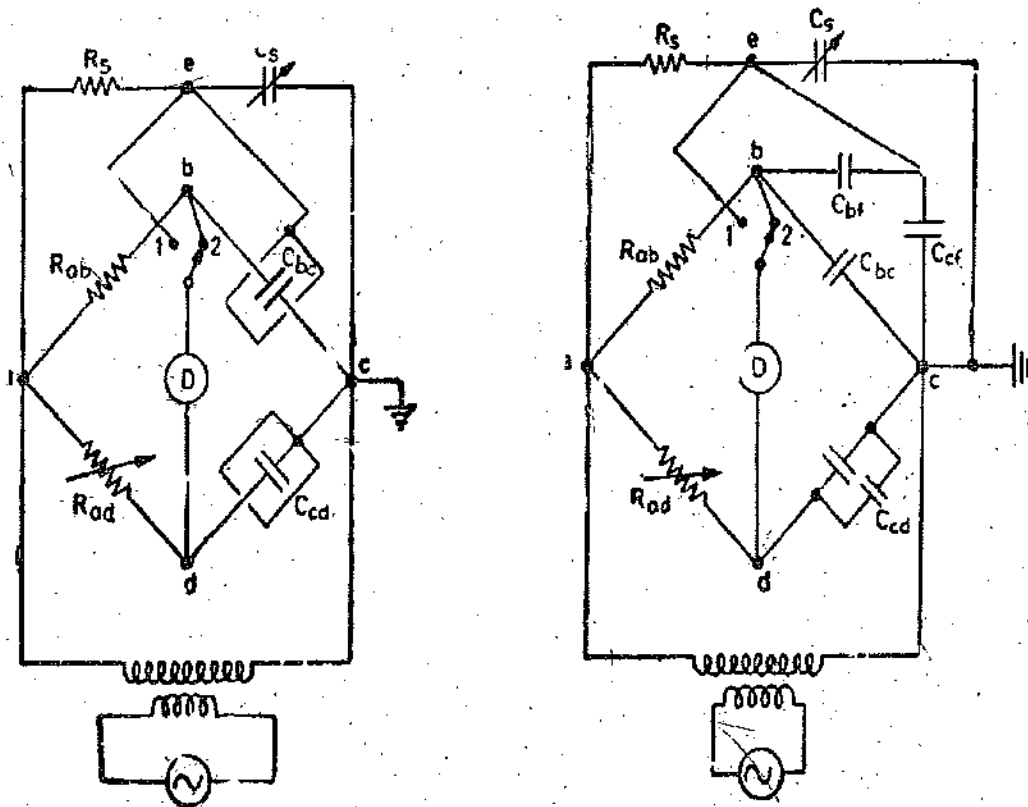

Fig 16'25

shunts the bridge arm, C_{br} . These capacitances do affect the bridge balance, because they are not definite in value and change according to external circumstances. Fig. 16'26 (a) shows capacitor C_{cd}



(a) Shielding of the capacitors in a capacitance Bridge.

(b) Equivalent circuit of the Bridge.

Fig. 16'26

shielded, with the shield connected to ground. If the capacitor C_{cd} is now calibrated within its shield, this calibration will give the total capacitance between points c and d . The unknown capacitance, C_{be} , is enclosed within a shield which is connected to point e of a shunting circuit R_s and C_b . This circuit is the same as the shunting circuit of the wagner ground connection of Fig. 16'27 except that point e is not connected to ground. The bridge is balanced by alternate adjustments of arms ad and cd , C_{cd} , being a variable capacitor and the shunting circuit, until there is no deflection of the detector when the switch is in either position 1 or 2. This means that point b is at the same potential as point e . If the circuit is redrawn into its equivalent circuit, replacing the shielded capacitors as shown in Fig. 16'26 (b), we find that point f of the three-terminal capacitance C_{be} is at the same potential as point b . This means that capacitor C_{bf} has no effect on the circuit. Capacitor C_{fe} shunts capacitor C_{be} and again, has no effect on bridge balance. Therefore, the unknown capacitance, C_{be} , can be measured without the effects of stray capacitance.

Shielding is effective in preserving the true magnitude of the components of a bridge. It is also important in keeping noise out of the measuring system. Both magnetic and electrostatic shielding are necessary to keep stray electro-magnetic and electrostatic fields from generating unwanted emf's in the bridge circuits. Be careful to shield the leads from an oscillator to a bridge and from the bridge to the detector. Be careful to provide only one ground connection to an a-c bridge; otherwise groundloop currents may produce serious noise in the system, resulting in measurement inaccuracy.

16'29. Wagner Earthing Device. If each component in a bridge has a defining screen connected to one end, a very high accuracy in measurement is made possible by the addition of a Wagner earthing arm. This device removes all the earth capacitances from the bridge network.

Fig. 16'27 shows the connections of the device for use in conjunction with the general form of bridge network, in which Z_1, Z_2, Z_3 and Z_4 are the impedances of the bridge arms. Z_5 and Z_6 are the two variable impedances of the Wagner earth branch, the centre point of which is earthed as shown. These impedances may consist of variable resistances and capacitances similar to those used in the arms of the bridge proper, but not necessarily of known value. The two impedances Z_5 and Z_6 must be capable of forming a balanced bridge with Z_1 and Z_3 or Z_2 and Z_4 and can be a duplicate of either of these pairs of arms. C_1, C_2, C_3 and C_4 are the stray earth capacitances appearing at the apexes of the bridge. D is the detector.

If the switch S is on contact d , balance of the bridge may be obtained by adjustment of the impedances Z_3 and Z_4 . The presence of the earth capacitances will prevent a true balance being obtained, but a point of minimum sound can be obtained.

After adjusting the bridge to give minimum sound, the switch S is thrown to contact e so that the telephones are then connected between b and earth; Z_5 and Z_6 are next adjusted until minimum sound is obtained. The telephones are next reconnected to b, d and Z_2 and Z_4 adjusted to give minimum sound again. The process is repeated until silence is obtained with the switch on d , and silence or the minimum attainable sound, with the switch on e . Then all three points b, d and e are at earth potential. Under these conditions no current flows in the earth capacitances C_2 and C_4 , and since C_1 and C_3 shunt the Wagner arms Z_5 and Z_6 , these capacitances are eliminated from the bridge network Z_1, Z_2, Z_3 and Z_4 .

The capacitances C_1 and C_3 , shunting Z_5 and Z_6 complicate these arms, and because of this the combination may not give a true balance against Z_2 and Z_4 , only a minimum being attainable during the Wagner balance. The existence of these capacitances should be borne in mind when deciding the form of the Wagner arm, which should preferably be composed of resistances and capacitances. Much of C_1 and C_3 will be due to the earth capacitance of the source transformer and a common cause of difficulty in achieving a good Wagner balance is due to the use of transformers with large and lossy earth capacitance. Poor insulation in the source transformer will cause resistance to appear shunting C_1 and C_3 .

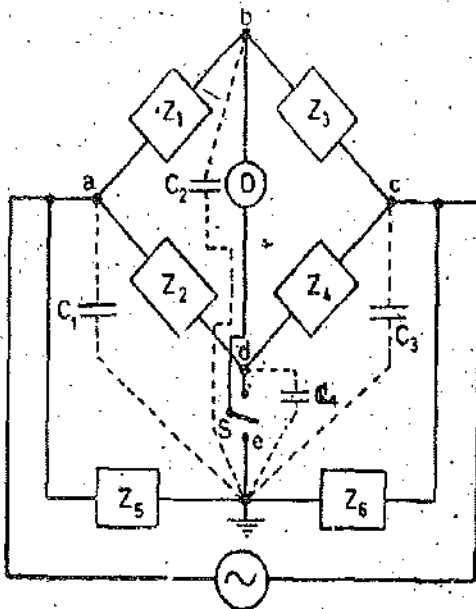

Fig. 16 27. Wagner earth device.

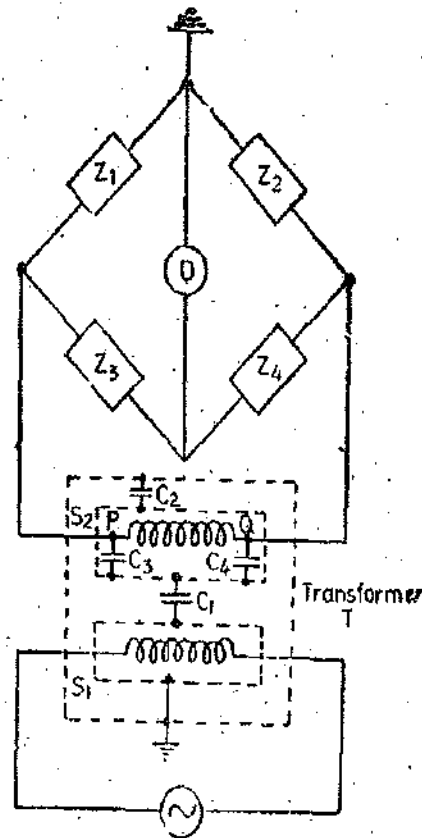

Fig. 16 28. Screened-and-balanced transformer.

16'30. Screened-and-balanced Transformers. Coupling between detector and source can be reduced by electrostatic screening between primary and secondary of the source transformer. Complete elimination of errors due to this can be effected in some cases by the use of a 'screened-and-balanced' transformer. This is illustrated in Fig. 16'28, where the secondary of the source transformer T is connected directly across a pair of equal ratio arms Z_2 and Z_4 , the junction of which is earthed. The primary and secondary windings of the transformer have screens S_1 and S_2 respectively, the whole being contained within an earthed metal case. If S_1 is connected to the case, all earth capacitance effects associated with the primary winding are eliminated. The most important remaining stray capacitances are those shown in the diagram. The effective capacitance between P and earth is $C_3 + \frac{1}{2}(C_1 + C_2)$; that between Q and earth is $C_4 + \frac{1}{2}(C_1 + C_2)$. If the transformer is so constructed that $C_3 = C_4$ the capacitances from P and Q to earth are equal. These capacitances shunt the arms Z_2 and Z_4 . Equal shunting effects on equal arms still give a unity ratio between the arms, so that earth-capacitance effects from the source do not affect the bridge balance condition of $Z_1 = Z_3$.

16'31. Difference and Substitution Methods. Improved accuracy of measurement may be obtained by using a 'difference' or 'double-reading' method. For example, a bridge for the measurement of capacitance may be set up and balanced with some auxiliary capacitor in the position of the unknown. Let the value of this capacitor, as determined by the bridge, be C_1 ; this value will, in general, be inaccurate due to stray effects and residuals in the bridge circuit. The capacitor under test, of capacitance C, is then connected in parallel with the auxiliary capacitor, and the bridge is re-balanced. Let the new value given be C_2 . Then, if it can be assumed that stray and residual effects have not altered, the difference between C_1 and C_2 is entirely due to the presence of the additional capacitor, so that $C = C_2 - C_1$.

An auxiliary component is not always necessary; the value of a capacitor may be obtained as the difference between the readings when it is connected to the bridge and when one lead to it is open-circuited at its terminal. Similarly, an inductance may be measured as the difference between two bridge readings, the first with the inductor in circuit and the second with the leads to the inductor short-circuited at its terminals.

Another method by which inaccuracies due to leads, residuals, and stray couplings may be considerably reduced is the method of substitution. In the simplest form of this method a bridge is balanced with the component under test in circuit. This component is then replaced by a variable standard component of a similar type—e.g., a capacitor is replaced by a standard capacitor. Balance is restored by adjustment of the substituted standard, the other bridge components left unaltered. Then the reading the standard must equal the component under test.

SOLVED EXAMPLES

Note. The students must attempt these problems from fundamentals although here direct formulae have been used since analysis has been done earlier.

Problem 16'3. A Maxwell's inductance comparison bridge is shown in Fig. 16'29. Arm ab consists of a coil with inductance L_1 and resistance r_1 in series with a non-inductive resistance R . Arm bc and ad are each a non-inductive resistance of 100Ω . Arm cd consists of standard variable inductor L of resistance 32.7Ω . Balance is obtained when $L=47.8$ mH and $R=1.36 \Omega$. Find the resistance and inductance of coil in arm ab .

Solution.

At Balance $[(R_1+r_1)+j\omega L_1] \times 100 = (r_2+j\omega L_2) \times 100$

Equating the real and imaginary terms

$$R_1+r_1=r_2 \text{ and } L_2=L_1$$

\therefore Resistance of coil :

$$r_1=r_2-R_1=32.7-1.36=31.34 \Omega.$$

Inductance of coil $L_2=L_1=47.8$ mH.

Example 16'4. A Maxwell's capacitance bridge shown in Fig. 16'4 is used to measure an unknown inductance in comparison with capacitance. The various values at balance :

$$R_2=400 \Omega ; R_3=600 \Omega ; R_4=1000 \Omega ; C_4=0.5 \mu\text{F}.$$

Calculate the values of R_1 and L_1 . Calculate also the value of storage (Q) factor of coil if frequency is 1000 Hz.

Solution. At balance $\left(R_1+j\omega L_1 \right) \left(\frac{R_4}{1+j\omega C_4 R_4} \right) = R_2 R_3.$

Separating the real and imaginary terms, we have

$$R_1 = \frac{R_2 R_3}{R_4} = \frac{400 \times 600}{1000} = 240 \Omega$$

and

$$L_1 = R_2 R_3 C_4 = 400 \times 600 \times 0.5 \times 10^{-6} = 0.12 \text{ H}.$$

Storage factor

$$Q = \frac{\omega L_1}{R_1} = \frac{2\pi \times 1000 \times 0.12}{240} = 3.14.$$

Example 16'5. An inductance of 0.22 H and 20Ω resistance is measured by comparison with a fixed standard inductance of 0.1 H and 40Ω resistance. They are connected as shown in Fig. 16 30 (a). The unknown inductance is in arm ab and the standard inductance is arm bc , a resistance of 750Ω is connected in arm cd and a resistance whose amount is not known is in arm da .

Find the resistance of arm da and show any necessary and practical additions required to achieve both resistive and inductive balance.

Solution. Now $R_1=20 \Omega ; L_1=0.22 \text{ H} ; R_4=750 \Omega ; R_3=40 \Omega ; L_2=0.1 \text{ H}$

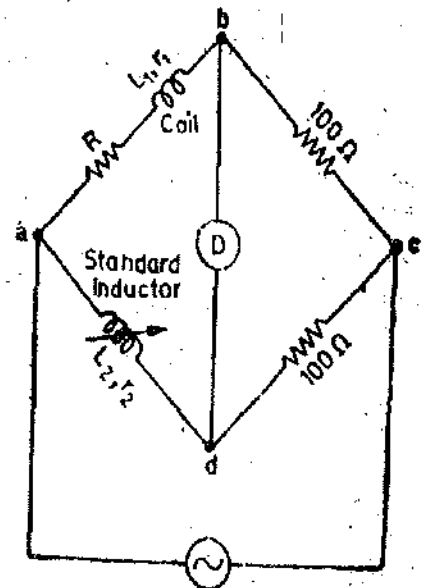

Fig. 16'29

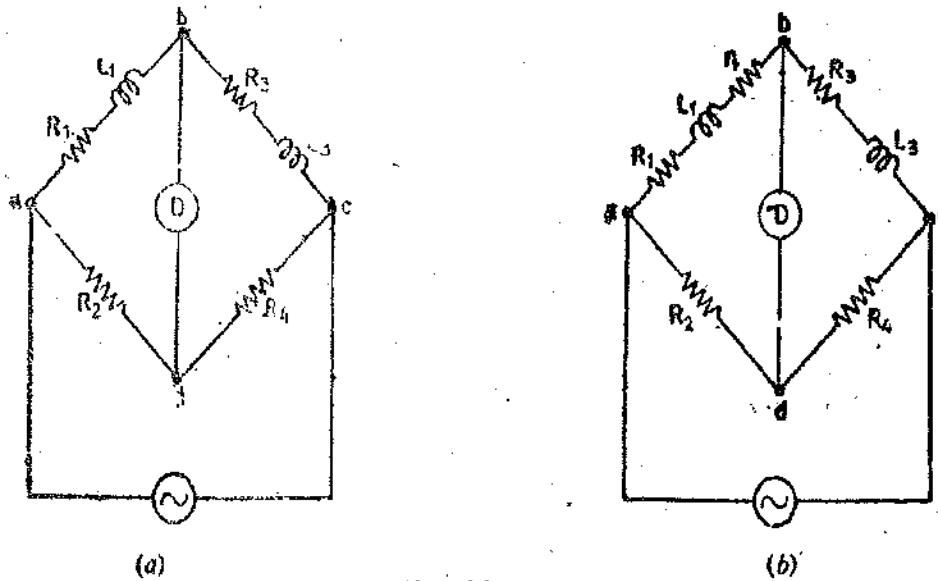

Fig. 16.30

At balance, $(R_1 + j\omega L_1)R_4 = R_2(R_3 + j\omega L_3)$

Thus the two balance equations are $R_1 = \frac{R_2 R_3}{R_4}$ and $L_1 = \frac{R_2 L_3}{R_4}$

From above we have : $\frac{L_1}{L_3} = \frac{R_2}{R_4} = \frac{R_1}{R_3}$

\therefore Value of R_2 required for balance : $R_2 = R_4 \frac{L_1}{L_3} = 750 \times \frac{0.22}{0.1} = 1650 \Omega$

and $\frac{L_1}{L_3} = \frac{R_2}{R_4} = 2.2$.

Now examine the value of ratio $\frac{R_1}{R_3}$ for the existing circuit we have :

$$\frac{R_1}{R_3} = \frac{20}{40} = 0.5.$$

The value of this ratio should be 2.2 for both resistive and inductive balance and therefore we must add a series resistance to arm ab . Let this series resistance be r_1 . Therefore

$$\frac{R_1 + r_1}{R_3} = 2.2 \quad \text{or} \quad r_1 = 2.2 \times 40 - 20 = 68 \Omega.$$

The modified circuit is shown in Fig. 16.30 (b).

Example 16.6. A bridge consists of the following :

Arm ab —a choke coil having a resistance R_1 and inductance L_1 .

Arm bc —a non-inductive resistance R_3 .

Arm cd —a mica condenser C_4 in series with a non-inductive resistance R_4 .

Arm da —a non-inductive resistance R_2 .

When this bridge is fed from a source of 500 Hz, balance is obtained under following conditions :

$$R_2 = 2410 \Omega ; R_3 = 750 \Omega ; C_4 = 0.35 \mu\text{F} ; R_4 = 64.5 \Omega.$$

The series resistance of capacitor is 0.4Ω . Calculate the resistance and inductance of the choke coil.

The supply is connected between a and c and the detector is between b and d .

Solution. When we draw the sketch of this bridge, we find that it is Hay's bridge shown in Fig. 16'5. The analysis of Hay's bridge is done in Art. 16'7.

Now from Eqns. 16'21 and 16'22, inductance and resistance of the coil are :

$$L_1 = \frac{R_2 R_3 C_4}{1 + \omega^2 C_4^2 R_4^2} = \frac{2410 \times 750 \times 0.35 \times 10^{-6}}{1 + (2\pi \times 500 \times 0.35 \times 10^{-6} \times 64.9)^2} = 0.63 \text{ H}$$

and
$$R_1 = \frac{\omega^2 R_2 R_3 R_4 C_4^2}{1 + \omega^2 C_4^2 R_4^2} = \frac{(2\pi \times 500)^2 \times 2410 \times 750 \times 64.5 \times (0.35 \times 10^{-6})^2}{1 + (2\pi \times 500 \times 0.35 \times 10^{-6} \times 64.9)^2} = 140.5 \Omega.$$

(Note that the resistance of arm *cd* is the sum of resistance of the series resistor and the series resistance of capacitor

i.e.
$$R_4 = 64.5 + 0.4 = 64.9 \Omega)$$

Example 16'7. The arms of a five node bridge are as follows :

- arm *ab* : an unknown impedance (R_1, L_1) in series with a non-variable inductive resistor r_1 ,
- arm *bc* : a non-inductive resistor $R_3 = 100 \Omega$, arm *cd* : a non-inductive resistor $R_4 = 200 \Omega$,
- arm *da* : a non-inductive resistor $R_2 = 250 \Omega$, arm *de* : a variable non-inductive resistor r ,
- arm *ec* : a loss less capacitor $C = 1 \mu\text{F}$, and arm *be* : a detector.

An a.c. supply is connected between *a* and *c*.

Calculate the resistance and inductance R_1, L_1 when under balance conditions $r_1 = 43.1 \Omega$ and $r = 229.7 \Omega$.

Solution. After drawing the network we find that it is the Anderson's bridge shown in Fig. 16'6 and dealt with in Art. 16'8

From Eqns. 16'26 and 16'27,

$$\text{Resistance } R_1 = \frac{R_2 R_3}{R_4} - r_1 = \frac{250 \times 100}{200} - 43.1 = 81.9 \Omega.$$

$$\text{Inductance } L_1 = \frac{C R_3}{R_4} \left[r(R_4 + R_2) + R_2 R_4 \right] = 1 \times 10^{-6} \times \frac{100}{200} \left[229.7(200 + 250) + 250 \times 200 \right] = 0.0766 \text{ H.}$$

Example 16'8. The four arms of a bridge are ;

- arm *ab* : an imperfect capacitor C_1 with an equivalent series resistance of r_1 ,
- arm *bc* : a non-inductive resistance R_3 , arm *cd* : a non-inductive resistance R_4 ,
- arm *da* : an imperfect capacitor C_2 with an equivalent resistance of r_2 in series with a resistance R_2 .

A supply of 450 Hz is given between terminal *a* and *c* and the detector is connected between *b* and *d*. At balance :

$$R_2 = 4.8 \Omega, R_3 = 2000 \Omega, R_4 = 2850 \Omega \text{ and } C_2 = 0.5 \mu\text{F} \text{ and } r_2 = 0.4 \Omega.$$

Calculate the value of C_1 and r_1 and also of the dissipating factor for this capacitor.

Solution. The bridge is shown in Fig. 16'31.

$$\text{At balance } \left(r_1 + \frac{1}{j\omega C_1} \right) R_4 = \left(r_2 + R_2 + \frac{1}{j\omega C_2} \right) R_3$$

Separating the real and imaginary terms

$$r_1 = (r_2 + R_2) \frac{R_3}{R_4} = (0.4 + 4.8) \times \frac{2000}{2850} = 3.65 \Omega.$$

and
$$C_1 = C_2 \frac{R_4}{R_3} = (0.5 \times 10^{-6}) \times \frac{2850}{2000} \text{ F} = 0.712 \mu\text{F}.$$

Dissipating factor

$$D_1 = \tan \delta_1 = \omega C_1 r_1 = 2\pi \times 450 \times 0.712 \times 10^{-6} \times 3.65 = 0.00734.$$

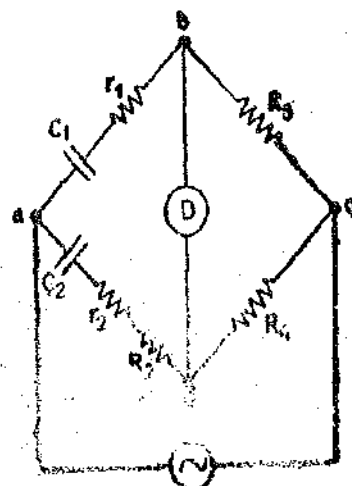

Fig. 16'31.

Example 16.9. An Owen's bridge is used to measure the properties of a sample of sheet steel at 2 kHz. At balance, arm *ab* is test specimen; arm *bc* is $R_3=100\ \Omega$; arm *cd* is $C_4=0.1\ \mu\text{F}$ and arm *da* is $R_2=834\ \Omega$ in series with $C_2=0.124\ \mu\text{F}$. Derive balance conditions and calculate the effective impedance of the specimen under test conditions.

Solution. Let R_1 and L_1 be the effective resistance and inductance of the specimen respectively.

$$\text{At balance : } (R_1 + j\omega L_1) \cdot \frac{1}{j\omega C_4} = R_3 \left(R_2 + \frac{1}{j\omega C_2} \right)$$

$$\therefore L_1 = R_2 R_3 C_4 = 834 \times 100 \times 0.1 \times 10^{-6} \text{ H} = 8.34 \text{ mH}$$

and
$$R_1 = R_3 \frac{C_4}{C_2} = 100 \times \frac{0.1}{0.124} = 80.7\ \Omega.$$

Reactance of specimen at 2 kHz

$$X_1 = 2\pi \times 2 \times 1000 \times 8.34 \times 10^{-3} = 104.5\ \Omega.$$

$$\text{Impedance of specimen } Z_1 = \sqrt{(80.7)^2 + (104.5)^2} = 132\ \Omega.$$

Example 16.10. A sheet of bakelite 4.5 mm thick is tested at 50 Hz between electrodes 0.12 m in diameter. The Schering bridge employs a standard air capacitor C_2 of 106 pF capacitance, a non-reactive resistance R_4 of $1000/\pi\ \Omega$ in parallel with a variable capacitor C_4 , and a non-reactive variable resistance R_3 . Balance is obtained with $C_4=0.5\ \mu\text{F}$ and $R_3=260\ \Omega$. Calculate the capacitance, power factor and relative permittivity of sheet.

Solution. The Schering bridge is shown in Fig. 16.11 where C_1 and r_1 represent the capacitance and series resistance of the capacitor.

From Eqns. 16.35 and 16.36,

$$r_1 = \frac{C_4}{C_2} \cdot R_3 = \frac{0.5 \times 10^{-6}}{106 \times 10^{-12}} \cdot 260 = 1.23 \times 10^6\ \Omega$$

and
$$C_1 = \frac{R_4}{R_3} C_2 = \frac{1000}{\pi \times 260} \times 106 \times 10^{-12} \text{ F} = 130 \text{ pF}.$$

$$\text{Power factor of sheet} = \omega C_1 r_1 = 2\pi \times 50 \times 130 \times 10^{-12} \times 1.23 \times 10^6 = 0.05$$

$$\text{Now capacitance } C_1 = \epsilon_r \epsilon_0 \frac{A}{d}$$

$$\therefore \text{Relative permittivity : } \epsilon_r = \frac{C_1 d}{\epsilon_0 A} = \frac{130 \times 10^{-12} \times 4.5 \times 10^{-3}}{8.854 \times 10^{-12} \times \frac{\pi}{4} (0.12)^2} = 5.9$$

where $\epsilon_0 = \text{permittivity of free space} = 8.84 \times 10^{-12} \text{ F/m},$

Example 16.11. In a low-voltage Schering bridge designed for the measurement of permittivity, the branch *ab* consists of two electrodes between which the specimen under test may be inserted; arm *bc* is a non-reactive resistor R_3 in parallel with a standard capacitor C_3 ; arm *cd* is a non-reactive resistor R_4 in parallel with a standard capacitor C_4 ; arm *da* is a standard air capacitor of capacitance C_2 . Without the specimen between the electrodes, balance is obtained with the following values; $C_3=C_4=120\ \text{pF}$, $C_2=150\ \text{pF}$, $R_3=R_4=5000\ \Omega$. With the specimen inserted these values become $C_3=200\ \text{pF}$, $C_4=1000\ \text{pF}$, $C_2=900\ \text{pF}$, and $R_3=R_4=5000\ \Omega$. In each test $\omega=5,000\ \text{rad/s}$. Find the relative permittivity of the specimen.

Solution. The bridge circuit is shown in Fig. 16.33.

$$\text{For balance } Y_1 Y_4 = Y_2 Y_3$$

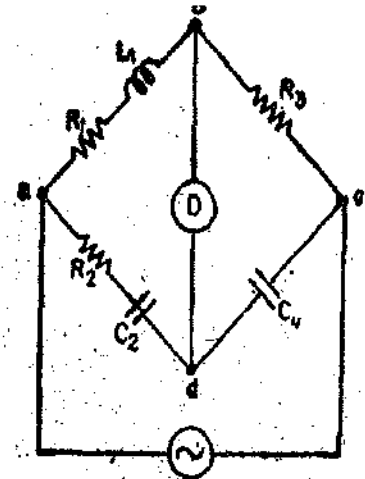

Fig. 16.32.

or $\left(\frac{1}{R_1} + j\omega C_1\right)\left(\frac{1}{R_4} + j\omega C_4\right) = (j\omega C_2)\left(\frac{1}{R_3} + j\omega C_3\right)$
 or $\left(\frac{1}{R_1 R_4} - \omega^2 C_1 C_4\right) + j\omega\left(\frac{C_4}{R_1} + \frac{C_1}{R_4}\right) = j\omega\frac{C_2}{R_3} - \omega^2 C_2 C_3$

Equating the real and imaginary parts, we have

$$\frac{1}{R_1 R_4} - \omega^2 C_1 C_4 = -\omega^2 C_2 C_3 \quad \dots(i)$$

and $\frac{C_4}{R_1} + \frac{C_1}{R_4} = \frac{C_2}{R_3} \quad \dots(ii)$

From (i) and (ii) we have: $C_1 = \frac{\frac{C_2 R_4}{R_3} + \omega^2 C_2 C_3 C_3 R_4^2}{1 + \omega^2 C_4^2 R_4^2}$

Now $\omega^2 C_2 C_3 C_4 R_4^2 \ll \frac{C_2 R_4}{R_3}$ and $\omega^2 C_4^2 R_4^2 \ll 1$.

Hence we can write $C_1 = C_2 \frac{R_4}{R_3}$

When the capacitor C_1 is without specimen dielectric, let its capacitance be C_0

$$\therefore C_0 = C_2 \frac{R_4}{R_3} = 150 \times \frac{5000}{5000} = 150 \text{ pF}$$

When the specimen is inserted as dielectric, let the capacitance be C_s .

$$\therefore C_s = C_2 \frac{R_4}{R_3} = 900 \times \frac{5000}{5000} = 900 \text{ pF}$$

Now $C_0 = \epsilon_0 A/d$ and $C_s = \epsilon_r \epsilon_0 A/d$

Hence relative permittivity of specimen $\epsilon_r = \frac{C_s}{C_0} = \frac{900}{150} = 6$.

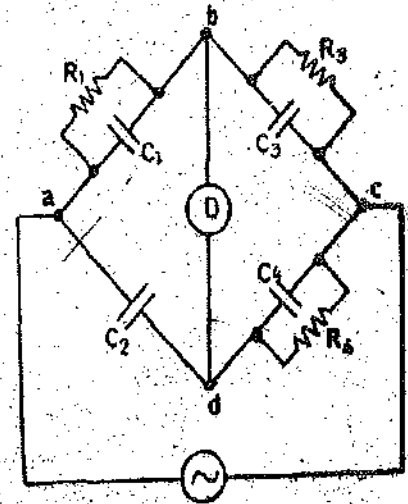

Fig. 16'33

Example 16'12. The arms of a four arm bridge $abcd$, supplied with sinusoidal voltage, have the following values :

Arm ab : A resistance of 200Ω in parallel with a capacitance $1 \mu\text{F}$.

Arm bc : 400Ω resistance. Arm cd : 1000Ω resistance.

Arm da : A resistance R_2 in series with a $2 \mu\text{F}$ capacitance.

Determine the value of R_2 and the frequency at which the bridge will balance.

Solution. If we draw the sketch of this bridge, we find that it is Wien's bridge shown in Fig. 16'22. The analysis of this bridge is given in Art. 16'20.

From Eqn. 16'63, $R_2 = \left(\frac{R_4}{R_3} - \frac{C_1}{C_2}\right)R_1 = \left(\frac{1000}{400} - \frac{1 \times 10^{-6}}{2 \times 10^{-6}}\right) \times 200 = 400 \Omega$.

From Eqn. 16'64, the frequency at which the bridge balances

$$f = \frac{1}{2\pi\sqrt{R_1 R_2 C_1 C_2}} = \frac{1}{2\pi\sqrt{200 \times 400 \times 1 \times 10^{-6} \times 2 \times 10^{-6}}} = 398 \text{ Hz.}$$

Example 16'13. Fig. 16'17 shows a Heaviside Campbell bridge for measurement of a self inductance L_2 with the equal ratios i.e. $R_3 = R_4$ the following results were obtained ;

With switch open— $M=15.8$ mH and $r=25.7$ Ω .

(With switch closed— $M=0.2$ mH and $r=11.2$ Ω .)

Find the resistance and self inductance of coil.

Solution. The theory of this bridge is dealt in Art. 16.18.

From Eqns. 16.51 and 16.53 for equal ratios

$$\text{Self-inductance } L_2 = 2(M_1 - M_2) = 2(15.8 - 0.2) = 31.2 \text{ mH}$$

$$\text{Resistance } R_2 = r_1 - r_2 = 25.7 - 11.2 = 14.5 \text{ } \Omega.$$

Example 16.14. A modified Carey Foster's bridge shown in Fig. 16.18 is used for measurement of capacitance. Arm ab contains a mutual inductance of 18.35 mH and a total non-reactive resistance of 200 Ω . The inductance of secondary of mutual inductor in arm ab is 40.6 mH. Arm ad is short circuited. Arm bc contains the unknown capacitor in series with a resistance of 119.5 Ω . Arm cd comprises of a resistor of 100 Ω resistance. The detector is across bd . Determine the capacitance and its equivalent series resistance.

Solution. From the analysis carried in Art. 16.19, we have :

$$\text{Capacitance } C_3 = \frac{M}{R_1 R_4} = \frac{18.36 \times 10^{-3}}{200 \times 100} \text{ F} = 0.918 \text{ } \mu\text{F}$$

$$R_3 = \frac{R_4(L_1 - M)}{M} = \frac{100(40.6 - 18.36)}{18.36} = 121.2 \text{ } \Omega.$$

$$\therefore \text{Series resistance of capacitor} = 121.2 - 119.5 = 1.7 \text{ } \Omega.$$

Example 16.15. In a modified Carey-foster bridge shown in Fig. 16.18. At balance $R_4=10$ Ω , $R_3=25.1 \pm 0.1$ Ω , $R_1=100$ Ω , $L_1=22.82$ mH and $M=4920 \pm 10$ μH . Find the unknown capacitance C_3 and the limits of accuracy determined by the limits of balance measurements indicated.

Solution. From Eqn. 16.59, we get

$$C_3 = \frac{M}{R_1 R_4} = \frac{4920 \pm 10}{100 \times 10} = 4.92 \pm 0.01 \text{ } \mu\text{F}.$$

$$\text{Accuracy limit} = \frac{0.01}{4.92} \times 100 = 0.2\%.$$

Example 16.16. Suppose in the above example the value of R_3 does not include the series loss resistance of capacitor, find the loss resistance and limits of its accuracy.

Solution From Eqn. 16.60,

$$R_3 = \frac{R_4(L_1 - M)}{M} = \frac{228200}{4920(1 \pm 10/4920)} = \frac{46.5}{1 \pm 10/4920}$$

$$= 46.5 \left(1 \mp \frac{10}{4920} \right) = 46.5(1 \pm 0.00204) = 46.5 \mp 0.095 \text{ } \Omega.$$

This resistance includes the series resistance of capacitor

$$\text{Series resistance of capacitor} = (46.5 \mp 0.095) - (25.1 \pm 0.1) = 21.4 \pm 0.195 \text{ } \Omega.$$

$$\text{Limits of accuracy} = \frac{0.195}{21.4} \times 100 = 0.915\%.$$

16.32. Transformer Ratio Bridges. The Transformer Ratio Bridges are becoming increasingly popular and are being used for a wide range of applications. This is on account of versatility and accuracy of Ratio Transformers, which are used in the transformer ratio bridges. In fact, transformer ratio bridges are replacing the conventional a.c. bridges at a rapid rate.

A transformer ratio bridge consists of voltage transformer whose performance approaches that of an ideal transformer. An ideal transformer is one that has no resistance, no core loss and no leakage flux (i.e. there is perfect coupling between the windings).

The ratio transformer is provided with a number of tappings in order to obtain voltage division.

Voltage appearing across the windings of a transformer is :

$$E = 4 K_f N \Phi_m f \text{ volt} \quad \dots(16'66)$$

where N = number of turns, Φ_m = maximum value of flux ; Wb

f = frequency ; Hz, and K_f = form factor (Its value is 1.11 for sinusoidal flux).

For a given value of K_f , flux Φ_m , and frequency f , $E = K_1 N$(16'67)

Fig. 16'34 shows an autotransformer provided with tappings. Suppose an alternating voltage E is applied across the winding. Assuming that the autotransformer is ideal type, the division of applied voltage E into output voltages E_1 and E_2 is :

$$E_1 = E \cdot \frac{N_1}{N} \text{ and } E_2 = E \cdot \frac{N_2}{N}$$

Different values of E_1 and E_2 may be had by changing the position of wiper on the tappings.

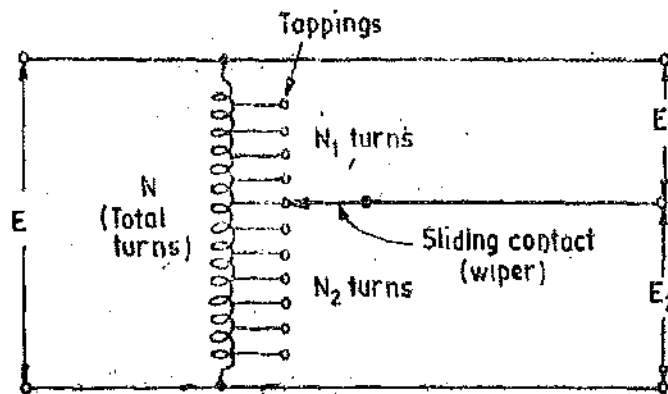

Fig. 16'34. Tapped autotransformer.

However, in practice it is impossible to construct an ideal transformer. But the ideals of zero winding resistance, zero core loss and perfect coupling can be closely achieved if the design features similar to those for instrument transformers are used. The material used for construction of core should be such that it gives the smallest core losses at the desired operating frequency. The magnetizing current is reduced by using a Toroidal Core. The added advantage of toroidal core is that winding put on it has minimum leakage reactance giving an almost perfect coupling. The leakage reactance can be reduced further by using a special type of construction for the windings as shown in Fig. 16'35. This winding takes the form of a Multi-conductor Rope. In order to obtain a decade of voltage division, the multiconductor rope has ten wires with successive sets of turns connected in series and a tapping is taken from each joint.

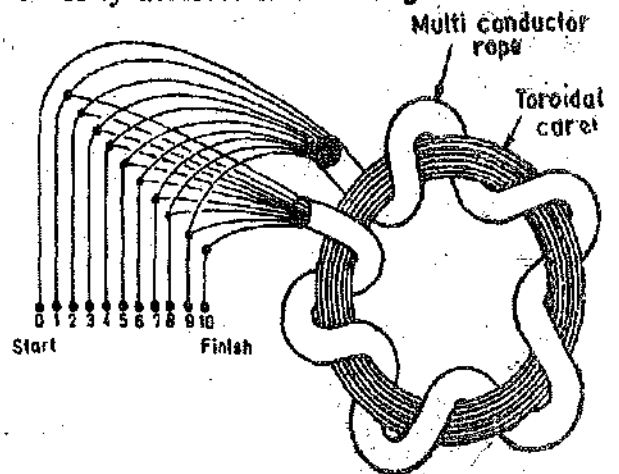

Fig. 16'35. Tapped ratio transformer using toroidal core and multiconductor rope type winding.

The resistance of the windings can be reduced by using copper wire of heavy cross-section.

A 4-decade ratio transformer is shown in Fig. 16'36. The successive decades are obtained by using an arrangement similar to that in a Kelvin Varley slide. This transformer arrangement give a ratio error of less than 1 part in 10^4 .

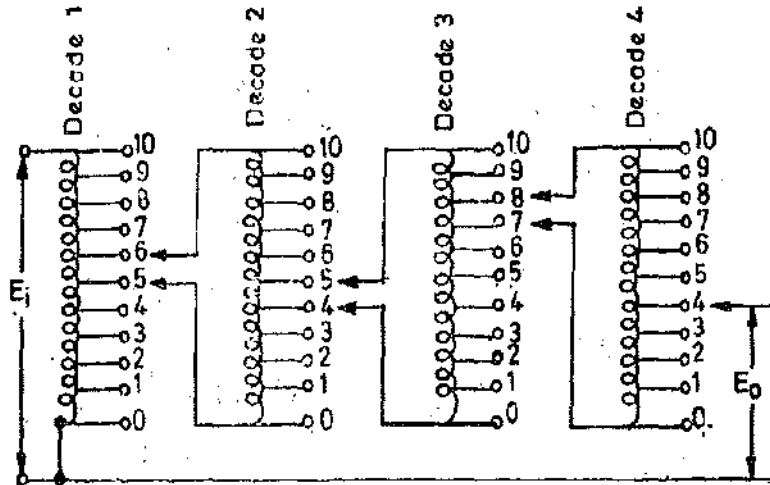

Fig. 16'36. Four decade ratio transformer.

16'33. Applications and Features of Ratio Transformers. Applications. The ratio transformers can be used for :

- (i) Measurement of resistance capacitance and inductance in comparison with standard resistance, standard capacitance and standard inductance respectively,
- (ii) Measurement of amplifier gain and phase shift, and
- (iii) Measurement of transformer ratios.

Features. The ratio transformers have the following features :

- (i) They can be used on a.c. only.
- (ii) They have very small ratio errors.
- (iii) They have a wide frequency range extending from 50 Hz to 50 kHz.
- (iv) They have high input impedance and low input impedance. Thus the loading effects in them are small.

16'34. Measurement of Resistance. The circuit used for measurement of an unknown resistance, R , in comparison with a standard resistance, R_s is shown in Fig. 16'37. The position of the wiper is adjusted till the detector D shows null. (The detectors used are the same as for conventional a.c. bridges).

$$\text{Current through the unknown resistance } I_1 = \frac{E_1}{R} = \frac{K_1 N_1}{R}$$

$$\text{Current through the standard resistance } I_2 = \frac{E_2}{R_s} = \frac{K_1 N_2}{R_s}$$

Under balance conditions, the current through the detector is zero i.e. $I_1 = I_2$.

$$\therefore \frac{K_1 N_1}{R} = \frac{K_1 N_2}{R_s} \quad \text{or} \quad R = \frac{N_1}{N_2} \cdot R_s \quad \dots(16'68)$$

A circuit used for measurement of low resistance is shown in Fig. 16'38. This circuit is similar to that of Kelvin's double bridge.

If the impedances of leads i.e. Z_1, Z_2, Z_3, Z_4 and Z_5 are small as compared to the resistances R and R_s are of the same order, the unknown resistance is given by :

$$R = \frac{N_1}{N_2} \cdot R_s \quad \dots(16'69)$$

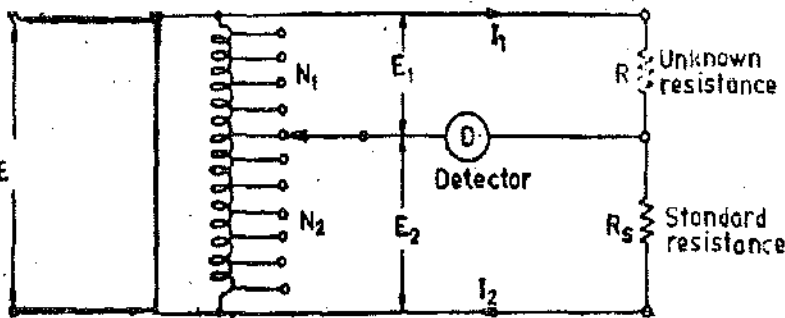

Fig. 16 37. Measurement of resistance using ratio transformer.

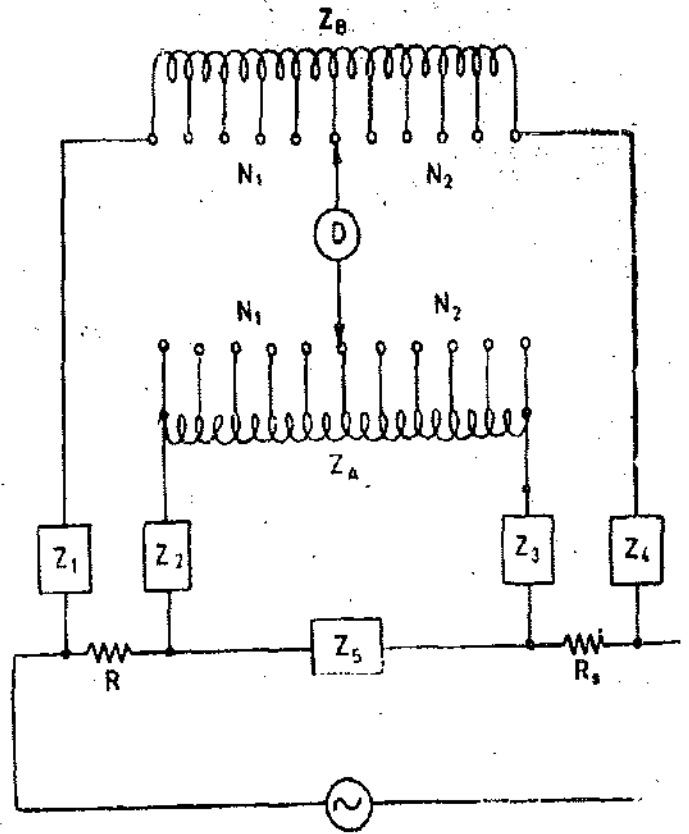

Fig. 16 38. Measurement of low resistance.

16.35. Measurement of Capacitance. A circuit for measurement of capacitance is given in Fig. 16.39. An unknown capacitance C is measured in comparison with a standard capacitance C_s , which is assumed to be perfect. Resistance R represents the loss of the capacitor. Since for balance, the magnitude and phase of the currents passing through the detector should be the same, a variable standard resistance is connected in parallel with the standard capacitor.

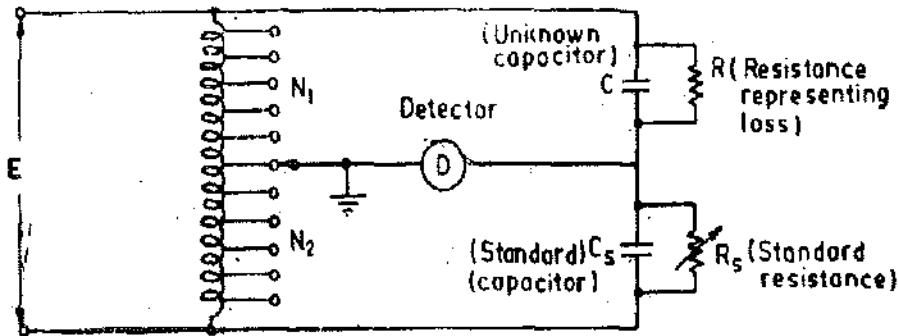

Fig. 16.39. Measurement of capacitance using ratio transformer.

At balance, $C = \frac{N_2}{N_1} \cdot C_s$... (16.70)

and $R = \frac{N_1}{N_2} \cdot R_s$... (16.71)

Dissipation factor $D = \tan \delta = \frac{1}{\omega CR} = \frac{1}{\omega C_s R_s}$... (16.72)

16.36. Measurement of Phase Angle. A circuit for measurement of small phase angles with the help of ratio transformers is shown in Fig. 16.40. An RC circuit is used where the capacitance is

variable in order to get phase shift. The value of resistance should be large in order that there are no loading effects on the ratio transformer. The capacitance is changed till the detector indicates null.

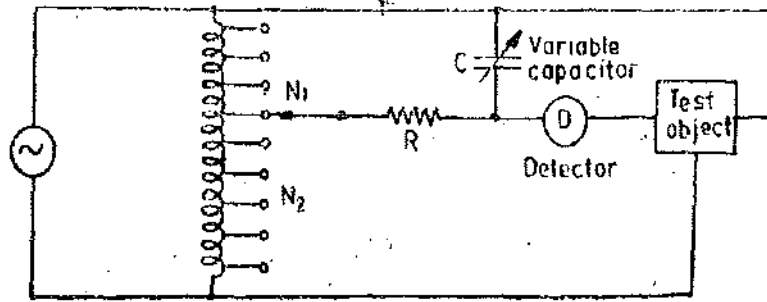

Fig. 16'40. Measurement of phase angle using ratio transformer.

Phase angle $\phi = \tan^{-1} (-\omega RC)$

The magnitude of in-phase component is : ...(16'73)

$$\phi_1 = \frac{N_2}{N_1 + N_2} \cdot \cos^2 \phi. \quad \dots(16'74)$$

16'37. Transformer Double Ratio Bridges. The transformer bridges described till now in this chapter are similar to the conventional a.c. bridges in the sense that the balance conditions are indicated when the voltage across the detector is zero and therefore, the current through the detector is zero.

An alternate way of indication of balance is that the current flowing through the unknown impedance is equal and opposite to that through the standard or known impedance. The detector indicates this condition of equality.

The arrangement of Transformer Double Ratio Bridges is shown in Fig. 16'41. It consists of an ideal voltage transformer having a secondary winding of N_1 turns. The secondary winding is tapped at N_2 turns. The resulting voltages E_1 and E_2 are applied across the unknown impedance, Z , and standard impedance, Z_s , respectively.

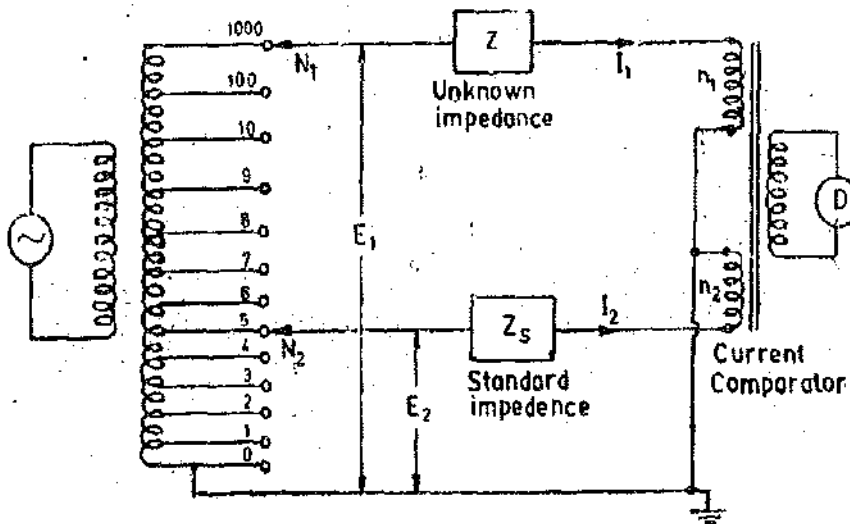

Fig. 16'41. Basic circuit for a double ratio transformer bridge.

The two voltages E_1 and E_2 produce currents I_1 and I_2 respectively. These currents flow in the windings n_1 and n_2 of a current comparator. The two mmfs $n_1 I_1$ and $n_2 I_2$ produce fluxes in the core of the comparator. The two fluxes oppose each other and when there is no flux in the core, no emf is induced in the secondary winding of the comparator and the detector D indicates null condition

At balance, the two mmfs are equal $\therefore I_1 n_1 = I_2 n_2$...(16'75)

Now $I_1 = \frac{E_1}{Z} = \frac{K_1 N_1}{Z}$ and $I_2 = \frac{E_2}{Z_s} = \frac{K_1 N_2}{Z_s} \therefore \frac{N_1 n_1}{Z} = \frac{N_2 n_2}{Z_s}$

or Unknown impedance $Z = Z_s \frac{N_1 n_1}{N_2 n_2}$... (16.76)

The balance is obtained by changing the setting of N_2 .

If the unknown impedance is a pure resistance R , a standard resistance R_s is required for obtaining balance.

$$R = \frac{N_1 n_1}{N_2 n_2} R_s \quad \dots (16.77)$$

If the unknown impedance is a pure capacitance C , a standard capacitor C_s is required for balance.

$$C = \frac{N_2 n_2}{N_1 n_1} C_s \quad \dots (16.78)$$

Eqn. 16.77 can also be converted to a form similar to that of Eqn. 16.78. This is done by using conductance in place of resistance.

$$\text{Unknown conductance } G = \frac{1}{R} = \frac{N_2 n_2}{N_1 n_1} G_s \quad \dots (16.79)$$

where G_s is the standard conductance.

In practice, the capacitors are not perfect, the losses being represented by a conductance in parallel with the capacitance. Therefore, balance has to be obtained both for resistance as well as for capacitance. In other words, mmf equality for both magnitude as well as for phase has to be obtained in order to get balance.

A circuit used for measurement of an imperfect capacitor in terms of standard capacitor and standard conductance is shown in Fig. 16.42.

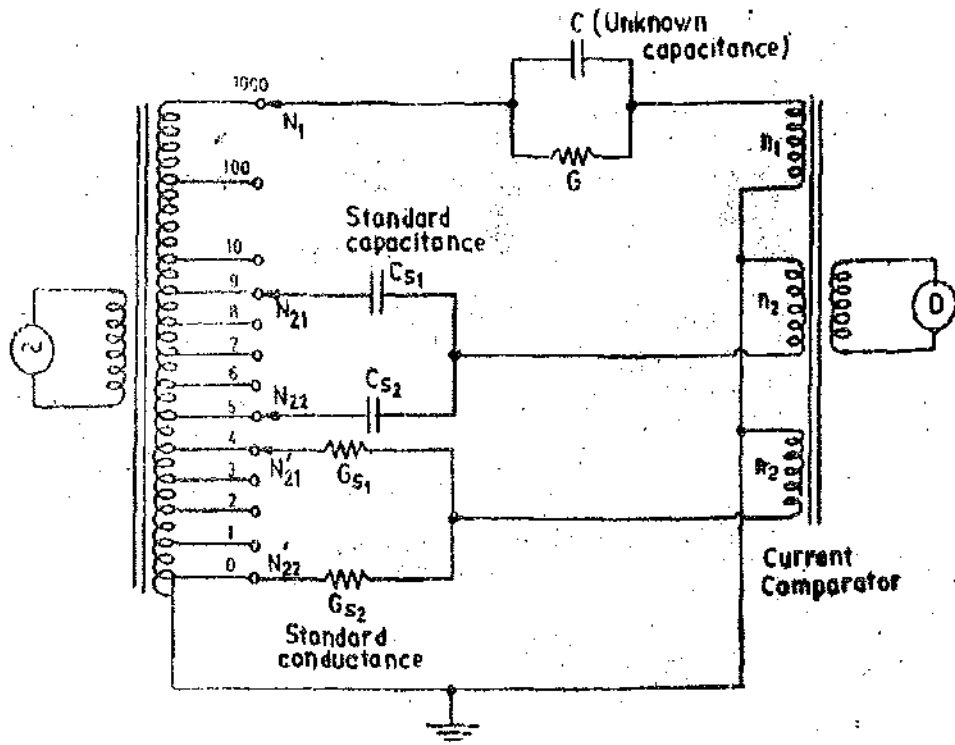

Fig. 16.42. Measurement of imperfect capacitor.

Under balance : $C = \frac{n_2}{N_1 n_1} (C_{s1} N_{21} + C_{s2} N_{22})$... (16.80)

$$\text{and } G = \frac{n_2}{N_1 n_1} (G_{s1} N_{21}' + G_{s2} N_{22}') \quad \dots(16'81)$$

It is clear from Eqns. 16'80 and 16'81, that the double ratio bridge allows the reactive and resistive components of an unknown to be adjusted independently of each other (capacitive balance can be had by changing N_{21} and N_{22} while resistive balance can be obtained by changing N_{21}' and N_{22}'). This property of independent balance facilitates the use of this bridge in a very wide range of applications.

16'38. Measurement of Inductance. The circuit for measurement of inductance is the same as that for measurement of capacitance (Fig. 16'43) except that the unknown capacitance is replaced by the unknown inductance.

In order that independent balance of the resistive and reactive mmfs can be obtained. Any inductive circuit must be considered as a two terminal network, the components of which are in parallel. The mmf due to the resistive component of the unknown may then be opposed by that through the conductance standard. On the other hand, the mmf due to inductive component of the unknown must be balanced due to capacitance standard. In order to obtain mmf balance due to unknown inductance and the standard capacitance, it is necessary to reverse the comparator winding connected to the standard capacitor. This condition of bridge operation is normally indicated by addition of a negative sign to the display of capacitance C_m .

Suppose an inductance L_p in parallel with a resistance R_p represents the actual inductor having an inductance L in series with a resistance R .

$$\text{At balance: } \frac{1}{R_p} + \frac{1}{j\omega L_p} = G_m - jC_m.$$

where G_m = indicated conductance, and C_m = indicated capacitance.

$$\therefore \text{ Series resistance } R = \frac{G_m}{G_m^2 + \omega^2 C_m^2} \quad \dots(16'82)$$

$$\text{and Series inductance } L = \frac{C_m}{G_m^2 + \omega^2 C_m^2} \quad \dots(16'83)$$

16'39. Measurements of Components in 'SITU'. One of the greatest advantages of double ratio transformer bridges is their capability to measure the values of the components while they remain connected in the circuit. Fig. 16'43 shows a circuit for measurement of an unknown

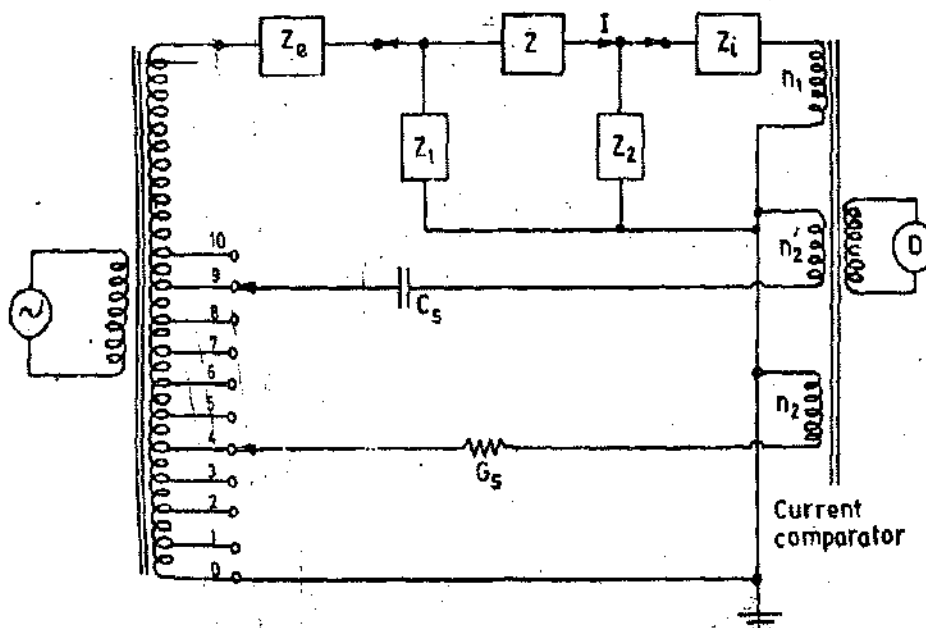

Fig. 16'43. Measurement of components 'IN SITU' using a double ratio transformer bridge.

A.C. BRIDGES

impedance Z_1 . If the ratio transformers are considered ideal the values of impedances Z_e and Z_i can be assumed to be zero and the voltage applied to the unknown impedance Z is not affected by current flowing in impedance Z_1 . Also all the current flowing through Z would flow into n_1 winding as :

$$I_2 = \frac{Z_i I}{Z_1 + Z_2}$$

The value of unknown impedance is approximately given by :

$$Z = \left[\frac{1}{G_m + j\omega C_m} \right] \left[1 - \left(\frac{Z_e}{Z_1} + \frac{Z_i}{Z_2} \right) \right] \quad \dots (16.84)$$

In practice impedances Z_e and Z_i have small finite values and corrections must be applied for this in order that corrections be applied Z_e and Z_i must be determined.

UNSOLVED PROBLEMS

Note. Students must attempt these problems from fundamentals.

1. A four arm a.c. bridge $a b c d$ has the following impedances :

Arm $a b$: $Z_1 = 200 \angle 60^\circ \Omega$ (inductive impedance).

Arm $a d$: $Z_2 = 400 \angle -60^\circ \Omega$ (purely capacitive impedance).

Arm $b c$: $Z_3 = 300 \angle 0^\circ \Omega$ (purely resistive).

Arm $c d$: $Z_4 = 600 \angle 30^\circ \Omega$ (inductive impedance).

Determine whether it is possible to balance the bridge under above conditions.

[Ans. No as $\angle \theta_1 + \angle \theta_4 \neq \angle \theta_2 + \angle \theta_3$]

2. A 1000 Hz bridge has the following constants : arm ab , $R_1 = 1000 \Omega$ in parallel with $C_1 = 0.5 \mu F$; arm bc , $R_2 = 1000 \Omega$ in series with $C_2 = 0.5 \mu F$; arm cd , $L_3 = 30 \text{ mH}$ in series with $R_3 = 200 \Omega$. Find the constants of arm da to balance the bridge. Express the result as a pure resistance R in series with a pure inductance L or capacitance C .

[Ans. $79.4 \angle -11.1^\circ \Omega$, R and C in series]

3. An a.c. bridge has in arm ab , a pure capacitance of $0.2 \mu F$; in arm bc , a pure resistance of 500Ω ; in arm cd , a series combination of a 50Ω resistance and of 0.1 H inductance. Arm da consists of a capacitor of $0.4 \mu F$ in series with a resistance R_1 . $\omega = 5000 \text{ rad/s}$. (a) Find the value of R_1 to give bridge balance. (b) Can complete balance be obtained by adjustment of R_1 ? If not, specify the position and the value of an adjustable resistance to complete the balance.

[Ans. 1000Ω , complete balance cannot be obtained by adjustment of R_1 only as reactive conditions are not satisfied. If an adjustable resistance of 200Ω is connected in series in branch cd capacitor reactive balance can be had]

4. The four arms of a Maxwell's capacitance bridge at balance are : arm ab , an unknown inductance L_1 , having an inherent resistance R_1 ; arm bc , a non-inductive resistance of 1000Ω ; arm cd , a capacitor of $0.5 \mu F$ in parallel with a resistance of 1000Ω ; arm da , a resistance of 100Ω .

Derive the equations of balance for the bridge and determine the value of R_1 and L_1 . Draw the phasor diagram of the bridge.

[Ans. $R_1 = 1000 \Omega$; $L_1 = 0.5 \text{ H}$]

5. In an Anderson Bridge for the measurement of inductance the arm AB consists of an unknown impedance with inductance L and R , a known variable resistance in arm BC , fixed resistance of 600Ω each in arms CD and DA , a known variable resistance in arm DE , and a condenser with fixed capacitance of 1 microfarad in the arm CE . The a.c. supply of 100 Hz is connected across A and C , and the detector is connected between B and E . If the balance is obtained with a resistance of 400Ω in the arm DE and a resistance of 800Ω in the arm BC , calculate the value of unknown R and L .

[Ans. $R = 800 \Omega$, $L = 1.12 \text{ A}$]

6. The four arms of a Hay's alternating current bridge are arranged as follows : AB is a coil of unknown impedance; BC is a non-reactive resistor of 1000Ω ; CD is a non-reactive resistor of 833Ω in series with a standard capacitor of $0.38 \mu F$; DA is non-reactive resistor of 16800Ω . If the supply frequency is 50 Hz - determine the inductance and the resistance at the balanced condition.

[Ans. $R_1 = 210 \Omega$, $L_1 = 6.38 \text{ H}$]

7. The a.c. bridge shown in Fig. 16.44 is used to measure an unknown inductance L_x , that has inherent resistance R_x . The bridge parameters are $R_1 = 20,000 \Omega$, $R_2 = 50,000 \Omega$, $C_2 = 0.003 \mu F$, $\omega = 10^4 \text{ rad/s}$. C_1 is adjustable from 10 pF to 150 pF , and R_4 is adjustable from 0 to $10,000 \Omega$. (a) Show that the equations for resistive and reactive balance are independent of each other. Derive expressions for R_x and L_x in terms of ω , R_1 , R_2 , R_4 , C_1 and C_2 . (b) Determine the largest values of R_x and L_x that are measurable with the given parameters.

[Ans. (a) $R_x = R_2 R_4 / R_1 + C_1 R_4 / C_2$; $L_x = R_1 R_4 C_1 - R_1 / \omega^2 R_1 C_2$. (b) $2.55 \times 10^4 \Omega$; 58.3 mH]

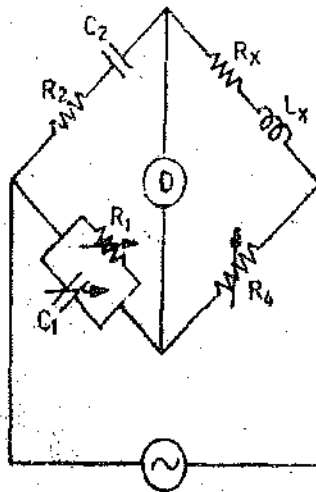

Fig. 16'44

8. The four arms of a bridge network are made up as follows : *a b*, a resistor of 50Ω in parallel with an inductor of 0.1 H ; *b c*, a resistor of 100Ω ; *c d*, an unknown resistor R in parallel with an unknown capacitor C ; *d a*, a resistor of 1000Ω . A 50 Hz voltage supply is applied across *a c*. Find R and C when a vibration galvanometer connected across *b d* is undeflected. [Ans. $R=7060 \Omega$; $C=0.72 \mu\text{F}$]

9. A four branch bridge network $ABCD$ balanced at 1000 Hz has branches AB and BC of pure resistance of 1000Ω and 1250Ω respectively. An unknown impedance forms the arm CD and the branch DA consists of a standard capacitor of $0.1 \mu\text{F}$ capacity and negligible resistance, connected in series with a non-reactive resistance of 10Ω to give balance. The supply voltage is 15 V and the supply is given at the points B and D . Find the components of unknown impedance and draw the necessary phasor diagram. [Ans. 12.5Ω ; $0.08 \mu\text{F}$]

10. The circuit for measurement of effective resistance and self-inductance of an iron cored coil is as follows :

arm *ab*, the unknown impedance; arm *bc*, a pure resistance R_2 ; arm *cd*, a lossless capacitor C_4 ; arm *da*, a capacitor C_1 in series with a resistance. Under balance conditions

$$R_1=10 \Omega, R_2=842 \Omega, C_1=0.135 \mu\text{F} \text{ and } C_4=1 \mu\text{F}.$$

Calculate the value of effective resistance and self-inductance at a supply frequency of 100 Hz .

[Ans. 74Ω , 8.42 mH]

11. A condenser bushing forms arm *ab* of a Schering bridge and a standard capacitor of 500 pF capacitance and negligible loss, forms arm *ad*. Arm *bc* consists of a non-inductive resistance of 300Ω . When the bridge is balanced arm *cd* has a resistance of 72.6Ω in parallel with a capacitance of $0.148 \mu\text{F}$. The supply frequency is 50 Hz . Calculate the capacitance and dielectric loss angle of capacitor. [Ans. 119 pF ; 0.00338 rad.]

12. An a.c. bridge was made up as follows : arms AB and BC equal ratio arms; CD a variable capacitor C in series with a variable resistor R ; DA a standard air capacitor of $0.001 \mu\text{F}$ in series with a fixed standard resistance of 500Ω . The supply at 796 Hz was connected across AC and the detector across BD . Balance of the above bridge was obtained with $C=5001 \mu\text{F} \pm 10 \text{ pF}$ and $R=500 \pm 5 \Omega$. When an unknown capacitor was connected across CD , the balance conditions changed to $C=360 \pm 10 \text{ pF}$ and $R=0$. Calculate the capacitance and power factor of the unknown capacitor and the limits of accuracy. [Ans. $650 \text{ pF} \pm 3.2\%$; $0.0039 \pm 0.002\%$]

13. A Schering bridge is used for measuring the power loss in dielectrics. The specimens are in the form of discs 0.3 cm thick and have a dielectric constant of 2.3 . The area of each electrode is 314 cm^2 and the loss angle is known to be 9 for a frequency of 50 Hz . The fixed resistor of the network has a value of $1,000 \Omega$ and the fixed capacitance is 50 pF . Determine the values of the variable resistor and capacitor required. [Ans. $4,200 \Omega$, $0.00196 \mu\text{F}$]

14. In a balanced bridge network, AB is a resistance of 500Ω in series with an inductance of 0.18 H ; BC and DA are non-inductive resistances of $1,000 \Omega$; and CD consists of a resistance R in series with a capacitance C . A potential difference of 5 volt at a frequency of $5,000/2\pi \text{ Hz}$ is established between the points A and C .

Draw to scale a phasor diagram showing the currents and potential differences in the bridge and from it determine the values of R and C .

Check the result algebraically.

[Ans. 472Ω ; $0.235 \mu\text{F}$]

15. A 4 arm unbalanced a.c. bridge is supplied from a source having negligible impedance. The bridge has non-reactive resistors of equal resistance in adjacent arms. The third arm has an inductor of resistance R and reactance X , where X is numerically equal to R . The fourth arm has a variable non-inductive resistor. The detector is connected

between the junction of first and second arms and the junction of third and fourth arms and has a resistance R and negligible reactance. Determine the magnitude of the variable resistor where the detector current is in quadrature with the supply current. [Ans. $1.37 R$]

16. An a.c. bridge consists of the following constants : arm ab , a resistance of 800Ω in parallel with a capacitance $0.4 \mu\text{F}$; bc , an unknown resistance; cd , a known resistance of 1200Ω and da , a resistance of 500Ω in series with a capacitance of $1 \mu\text{F}$. Find the resistance required in arm bc to give balance and also the frequency for which the bridge is balanced. [Ans. 384Ω ; 890 Hz]

17. A 4-arm bridge network, adjusted to balance conditions consists of :

Arm AB a standard resistor known to be within 0.1% of 100Ω .

Arm BC a variable capacitor adjusted to $0.362 \mu\text{F}$ in parallel with a variable resistor adjusted to 2380Ω .

Arm CD a standard resistor known to be within 0.1% of 1000Ω .

Arm DA a coil of inductance L and series loss resistance R .

Evaluate L and R deriving the equations used.

Determine the maximum percentage error that can be tolerated in each of the variable components if L is to be determined to within 0.5% and R to within 1% of the correct value. If the variable components are known to be accurate within the limits so determined how accurately is the ratio L/R known?

[Ans. 0.0362 H ; 42Ω ; 0.3% for capacitor; 0.8% for resistor; 1.1%]

18. A low-resistance coil AB of 500 turns is wound on a ring of high permeability magnetic alloy, and a tapping is made at a point C such $AC=100$ turns. A secondary winding on the same ring is connected to an amplifier and headphones, and a supply at 796 Hz is connected between C and a point D , so that $ACBD$ forms a bridge circuit in which the two parts AC and BC of the winding are the ratio arms. Balance is achieved when a branch AD comprises a capacitance of $0.16 \mu\text{F}$ in series with a resistance of 0.4Ω , and arm BD is the capacitor under test.

Evaluate the capacitance and the equivalent shunt loss resistance of the capacitor at supply frequency.

Mention the special advantages of this form of bridge circuit over the more conventional forms.

[Ans. $0.04 \mu\text{F}$; $976 \text{ k}\Omega$]

19. A balanced Hay's bridge shown in Fig. 16.5 has

$$R_2 = R_3 = 1000 \Omega, R_1 = 8120 \Omega, C_1 = 980 \mu\text{F}$$

and the frequency = 4000 Hz . Calculate L_1 and R_1 .

If each of the resistor is accurate within $\pm 0.5\%$, the capacitor within $\pm 1 \mu\text{F}$, and the frequency within 5 Hz , determine the limits of accuracy of determination of L_1 .

[$L_1 = 942.3 \times 10^{-6} (1 + 0.00181) \text{ H}$; accuracy limit $\pm 0.18\%$]

20. A resonance bridge is shown in Fig. 16.45. Prove that

$$C = \frac{1}{\omega^2 L}, \quad L = \frac{1}{\omega^2 C} \quad \text{and} \quad f = \frac{1}{2\pi\sqrt{LC}}$$

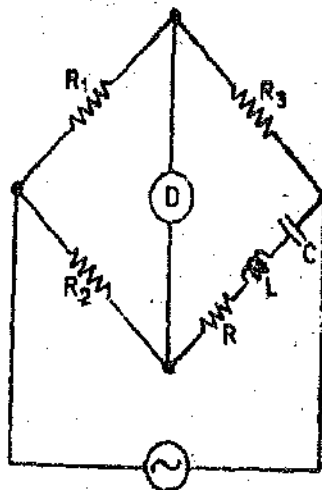

Fig. 16.45. Resonance bridge.

High Voltage Measurements and Testing

17.1. Types of Tests. The growing extension, interconnections and use of higher voltages in electric power systems has been only possible due to extensive research work carried in the sphere of high voltage measurements and testing. Due to this research work in the high voltage field, it has been possible to reduce the size of the equipment to economic and manageable proportions. Thus it is logical that the high voltage testing of electric equipment has come into prominence and sometimes it is the sole design criterion for the determination sizes of electrical apparatus.

High voltage testing includes a large number of methods. Due to limitations of space, we will be considering a few important methods only. The high voltage tests are classified as :

1. Sustained low frequency tests.
2. Constant direct current tests.
3. High frequency tests.
4. Surge or Impulse tests.

1. Sustained Low Frequency Tests. These tests are most commonly used. The frequency employed is 50 Hz in India. These tests are carried out on :

(i) Motors, switchgears and other electrical apparatus for routine voltage testing after manufacture or in some cases after installation. The voltage normally used is 2 to 3 kV.

(ii) Specimens of insulation for the determination of dielectric constant and dielectric loss.

(iii) Supply mains for routine testing.

(iv) High voltage transformers, porcelain insulators and high voltage cables, etc. for works testing. The test voltage in such cases may be as high as 2000 kV.

2. Constant Direct Current Tests. Modern trend in electric power transmission is to use as high voltages as possible. This is because increase in transmission voltage results in an increase in efficiency of transmission. Overhead lines are in actual operation which employ a voltage as high as 750 kV.

Before high voltage lines are energised, the insulation of every part connected with the lines must withstand continuously for half an hour, a voltage as specified below :

<i>Normal system voltage</i>	<i>Test voltage</i>
Below 10 kV	Twice the normal voltage
Above 10 kV	Normal voltage + 10 kV

From above it is clear that the transmission lines and high voltage cables would be subjected to very high voltages for a considerably long interval of time, (i.e., 30 minutes). If such voltage tests are carried out with an a.c. voltage supply, the high voltage transformer required for the purpose would have to be of a very large capacity owing to the heavy charging (capacitive) currents drawn by the lines or the cables. This means that a large expenditure has to be incurred for procuring the high voltage testing transformer. Also there would be great difficulties involved in transporting the testing transformer to the site of testing owing to its large size.

Thus in order to overcome the difficulties encountered above, high voltage d.c. testing is done in place of a.c. testing.

3. High Frequency Tests. The break-down and flashover of porcelain insulators used on power transmission lines is often due to high frequency disturbances in the transmission lines. These high frequency disturbances are either due to switching operations or due to some external causes and are usually damped high frequency oscillations.

It has been found that even though the porcelain insulator has satisfactorily withstood the sustained low frequency high voltage tests, it breaks down at a much lower voltage at high frequencies owing to increased dielectric loss and heating. Thus to insure reliable operation of insulators under disturbances caused by switching and arcing earths, they must be subjected to high frequency tests.

High frequency tests are also carried out for insulators used for communication purposes. Frequencies ranging from several kHz to a MHz or more are used for such purposes.

4. Surge or Impulse Tests. These tests are recommended with the object of determining the effect of voltage surges due to atmospheric disturbances of very short duration on electrical installations and their individual parts. The dangerous over voltages to which power systems are exposed to are caused by lightning. Lightning may produce an overvoltage on an overhead line either by a direct stroke to the line or by an indirect stroke. An indirect stroke occurs when a charged cloud above and near to the line, electrostatically induces charges of opposite sign to that of its own charge, in line. These charges are bound as long as the cloud remains near without discharging its electricity by a lightning stroke. But if the cloud is suddenly discharged, the induced charges in the line are no longer bound, but travel with the velocity of light along the line to equalize the potential everywhere. The result is that a voltage wave travels along the line. The nature of the wave is shown in Fig. 17'1. The wave is characterised by a steep-rise of voltage up to its peak value followed by a slower drop to zero voltage. The probable maximum voltage appearing on a line due to direct stroke is 10-15 MV and that by an indirect stroke is 500 kV. Fortunately direct strokes are rare.

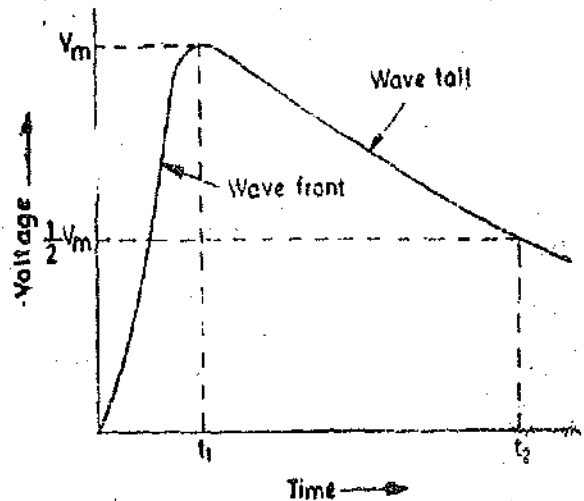

Fig. 17'1. Surge wave.

The danger to the electric installations comes from the fact that this overvoltage acts across the insulation and that the time taken by the voltage to rise to its peak value is very small, i.e., of the order of one millionth of a second. This imposes very severe voltage stresses on the insulators, transformer windings, circuit breaker bushings and other equipment. If the voltage stress exceeds the strength of the insulation, a flashover or a puncture results causing a short circuit and power outage. If a power arc follows, there may be disastrous results in damage to equipment whose repair may cost considerable amount of money and time.

Since power systems are frequently exposed to lightning strokes and consequent voltage surges, impulse testing is necessary for coordination of insulation of the system in order that these surges are not allowed to damage the insulation of the important associated equipment.

17.2. Testing Apparatus. The following testing apparatus is used for sustained low frequency tests. This apparatus is usually common for all types of high voltage tests.

- | | |
|--|---|
| (i) High voltage testing transformer. | (ii) Equipment for voltage regulation. |
| (iii) Control gear and protective devices. | (iv) Equipment for voltage measurement. |

In addition to above, high voltage d.c. tests, high frequency tests and impulse (surge) tests require some other apparatus also which will be described along with these tests.

17.3. High Voltage Transformers. High voltage transformers are usually single phase core type, oil immersed self cooled type. The design of these transformers is in many respects similar to that of normal power transformers. However, the insulation of these transformers is very carefully

designed not only because the secondary voltage is high but because of the fact that they are subjected to transient voltages and surges which are set up when the insulation under test breaks down.

The transformers used for insulation testing need not be of a high kVA rating because the current taken by the transformer is limited by inserting external resistances when the specimen under test breaks down. However, transformers used for cable testing are designed to deliver large currents owing to capacitive (charging) currents drawn by the cables. Attention must be paid to regulation and cooling methods employed for such transformers.

Special constructional features are incorporated in high voltage transformers to eliminate corona effects as far as possible. The high voltage terminal of the secondary winding and all other metal parts which have a high potential with respect to earth, must be constructed in such a manner that sharp corners are avoided. This is done to avoid excessive voltage gradients which cause corona. If this arrangement is not possible, corona shields (which are usually aluminium spinings) should be provided.

For voltages upto about 500 kV, a single transformer is used. For voltages above 500 kV, the connection of two or more transformers in cascade is more economical than the use of a single transformer because at very high voltages a single-transformer tends to be of very large size and is thus costly.

A general arrangement of two transformers connected in cascade is shown in Fig. 17'2.

A low voltage supply is given to the primary winding of transformer 1. The tank of this transformer is earthed. One end of the secondary winding of this transformer is also earthed. A lead is taken from the other end of the secondary winding. This lead is taken out of the transformer through a high voltage bushing which provides insulation for full secondary voltage between this lead and the tank (earth). The secondary winding is tapped at a point and another lead is taken out of the tank through the h.v. bushing. These two leads are connected to the primary of transformer 2.

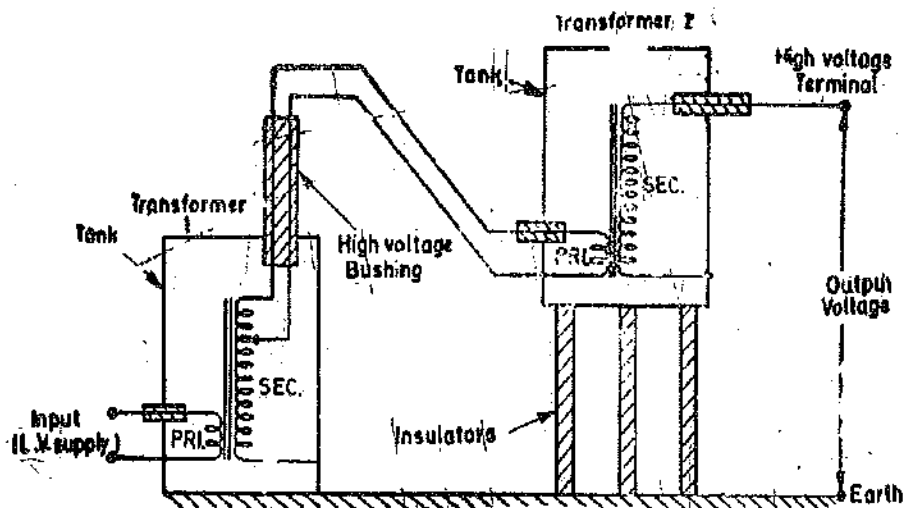

Fig. 17'2. Cascade connection of transformers.

One end of the secondary winding of transformer 2 is connected to the tank which is insulated from earth for a voltage equal to the secondary voltage of transformer 1. The other end of the secondary winding of transformer 2 is taken out with the help of a lead passing through a high voltage bushing. This lead forms the high voltage terminal of the transformer. The output voltage for test purpose, is taken between the h.v. terminal and earth. It is the sum of the secondary voltages of the two transformers. The output voltage can be increased further by addition of more transformers connected in cascade.

17'3. Voltage Control. It is very important in high voltage measurements that the output voltage which is fed to the test specimen is varied smoothly. Any abrupt or crude change in voltage will impress voltage surges on the specimen and will also effect the accuracy of measurements. It is equally important that the voltage regulating device should not distort the waveform of output voltage.

The method of voltage regulation depends upon whether a separate alternator is being used to supply the testing transformer or an available supply is being fed to the testing transformer. A separate alternator is normally used except in the case of small testing establishments which carry out routine testing work.

When a separate alternator is used, the voltage regulation is done by variation of the alternator field current.

In case separate alternator is not used, the voltage regulation is done :

- (i) by insertion of resistance in the supply circuit,
- (ii) by insertion of inductance in the supply circuit,
- (iii) by means of a tapped transformer,
- (iv) by means of a variac,

and (v) by means of an induction regulator.

17.5. Voltage Control by Variation of Alternator Field Current. This method is applicable when a separate alternator is used to supply the testing transformer. When the field current of an alternator is varied its output voltage changes as shown in Fig. 17.3.

The alternator used should give a sinusoidal output voltage at no load and the distortion caused under load conditions should be small. This requires the length of air gap of the machine should be large, as in that case the armature reaction is limited and also there is no saturation owing to increased reluctance offered by a large air gap length.

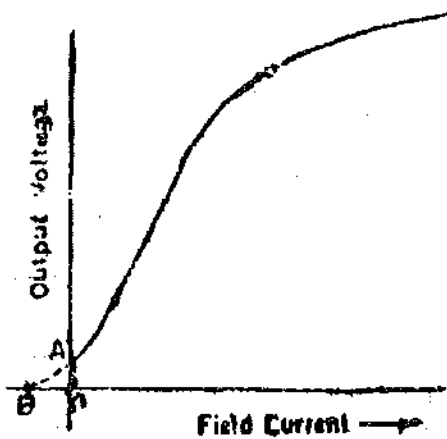

Fig. 17.3. Variation of output voltage of alternator with field current.

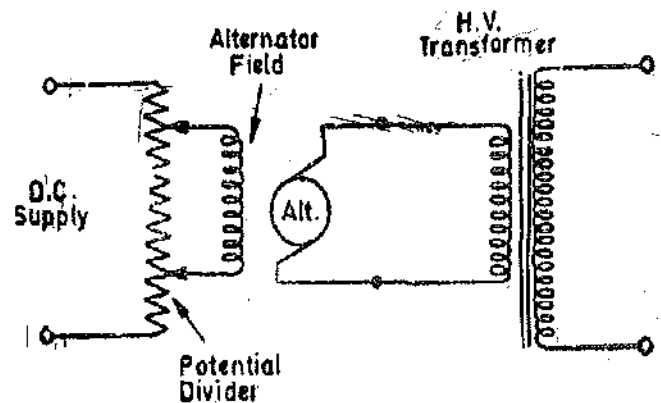

Fig. 17.4. Voltage control by use of a potential divider in the field circuit of alternator.

The armature winding of the alternator should be specially designed and also the number and shape of slots should be properly regulated so that the output voltage wave shape does not contain lower order or higher order (slot) harmonics.

The field current of the alternator is directly varied in the case of large alternators but in the case of large alternators, the field current of exciter is varied, which varies the output voltage of the exciter thus varying the alternator field current.

Fig. 17.4 and Fig. 17.5 show the two connections employed. A potential divider arrangement is used in both the cases and the connections are so arranged that a small current in the reverse direction to the normal one may be obtained. Thus for this arrangement zero output voltage is obtained. Referring to Fig. 17.3 the output voltage due to residual magnetism is OA and a field current OB (in the reverse direction) is required to bring the output voltage down to zero.

The potential divider is designed to have a large number of turns so that a gradual smooth variation of output voltage is obtained.

The advantages of this method are :

- (i) Smooth voltage regulation from zero to full voltage is obtained.

(ii) There are no impedances in the circuit of supply to the h.v. transformer and therefore the input voltage waveform is not distorted.

(iii) The method is convenient and simple.

(iv) There are no disturbances caused due to frequent short circuiting of secondary winding of h.v. transformer owing to breakdown of test specimens.

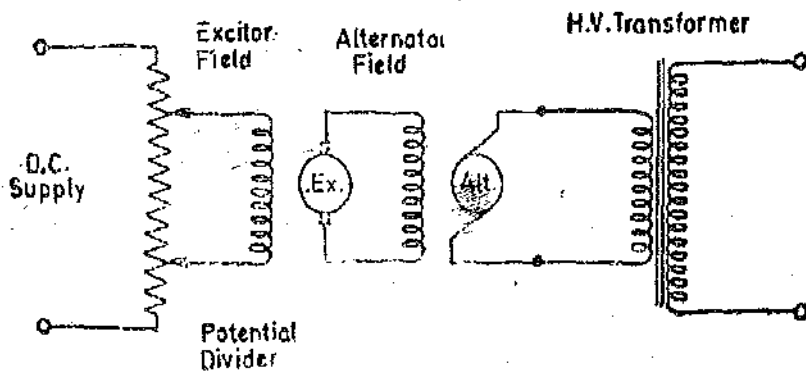

Fig. 17.5. Voltage control by use of a potential divider in the field circuit of the exciter of alternator.

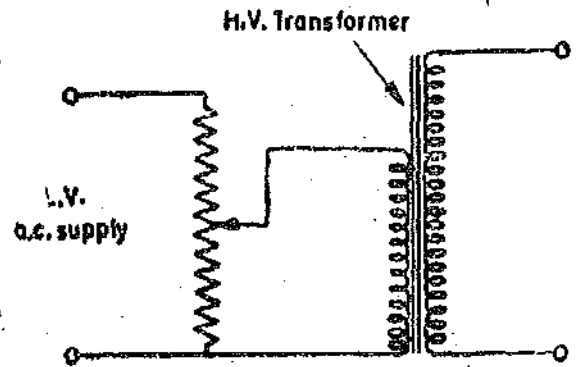

Fig. 17.6. Voltage control by resistance potential divider.

17.6. Voltage Control by Resistance Potential Divider. This method is used when a separate alternator is not used. Potential divider arrangement as shown in Fig. 17.6 is preferred to a series resistance. This is because a smooth voltage regulation from zero to full voltage is obtained. This method is usually used for small capacity sets of about 2--3 kVA.

The method has the following advantages :

- (i) It is cheap and convenient.
- (ii) It gives smooth voltage variation.
- (iii) The input voltage is free from distortions.

However the method suffers from the following disadvantages :

- (i) There is a power loss in the potential divider.
- (ii) The arrangement cannot be used for large capacity plants owing to very large size and heavy costs of the resistance potential divider.

17.7. Reactance Voltage Control. A choke coil connected in series with the primary of the h.v. testing transformer may be used for voltage regulation. The arrangement is shown in Fig. 17.7 wherein a choke of variable inductance is used. The reactance of the choke can be varied by withdrawal or insertion of iron core of the coil and thus the input voltage to h.v. testing transformer can be varied.

The advantage of this method is that there is considerably smaller power loss owing to use of a choke coil in place of a resistance and consequently the efficiency is high. The method suffers from many disadvantages :

- (i) The size of the coil is large when the power to be handled is large.
- (ii) Due to non-linear characteristics of the iron core of the choke coil the input voltage waveform is distorted.
- (iii) The power factor of the load is usually leading as test specimens are insulating materials and therefore the use of a choke coil results in an increase in the input voltage to the transformer with increase in load.

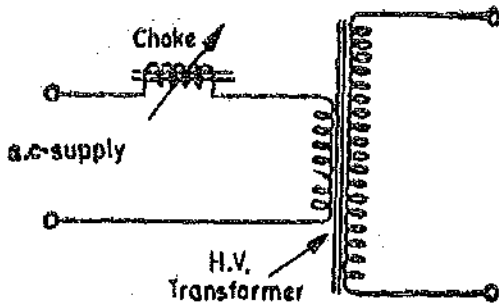

Fig. 17.7. Variation of voltage by using series reactance.

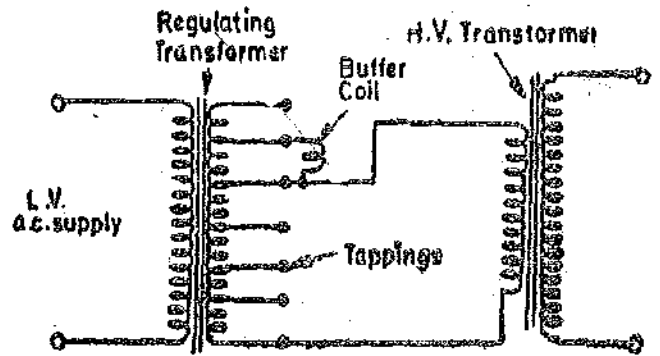

Fig. 17.8. Voltage control by a tapped transformer.

17.8. Voltage Control by Tapped Transformer. Fig. 17.8 shows the arrangement for voltage regulation with the help of a tapped transformer. An intermediate regulating transformer is used for the purpose of tappings. The primary winding of the tapped transformer is supplied from a l.v. supply. The secondary winding of this transformer is provided with a number of tappings with the help of which the voltage fed to primary of the h.v. testing transformer can be varied. In order to avoid surges due to sudden opening of secondary circuit of regulating transformer when the tapping switch is moved, two contact brushes are used which make contacts with adjacent tapping points. A buffer resistor or a reactance coil is used between the two contact brushes to prevent the short-circuiting of a portion of the secondary winding by the brushes.

In order to obtain smooth voltage regulation a large number of tappings should be used. The advantages of this method are :

- (i) It has a high efficiency.
- (ii) It gives a very small distortion of voltage waveform.

The disadvantages are :

- (i) The voltage regulation is not smooth unless a large number of tappings is used.
- (ii) The equipment becomes expensive if the power to be handled is large.

17.9. Voltage Control by Variac. A variac may be used to supply the h.v. transformer. The arrangement is simple and is shown in Fig. 17.9. The method has the advantage that it gives smooth voltage regulation from zero to full value of voltage.

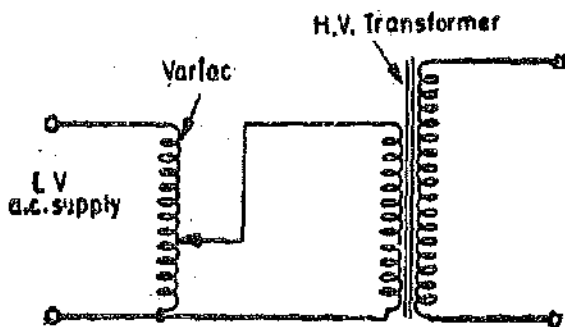

Fig. 17.9. Voltage control by variac.

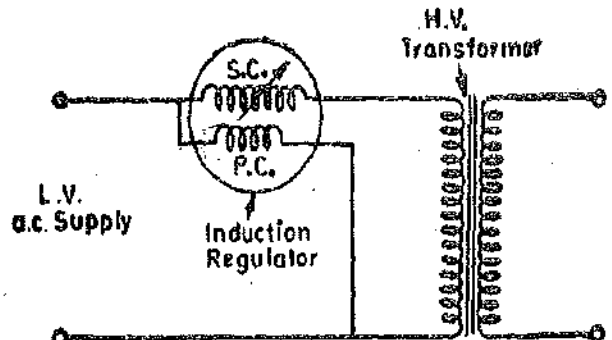

Fig. 17.10. Voltage control by induction regulator.

17.10. Voltage Control by Induction Regulators. An induction regulator may be used to give a smooth voltage regulation. The voltage is varied by changing the position of secondary winding with respect to primary. The connections are shown in Fig. 17.10. If the primary and secondary windings of an induction regulator have equal number of turns, the voltage supplied to the primary winding of the high voltage transformer can be varied from zero to $2E$ where E is the induced voltage of each winding of induction regulator.

The advantages of this method are :

- (i) It gives a gradual and a smooth voltage regulation.

(ii) It can be used for all loads and power factors.

(iii) Voltage waveform distortion can be avoided by using a carefully designed induction regulator.

(iv) This method of voltage regulation is particularly suited for cable testing equipment owing to its adaptability for any load.

17.11. Control Gear and Protective Devices. The primary side of the high voltage transformer is provided with :

(i) *Main Switch.* It is required to isolate the testing apparatus from the supply.

(ii) *Fuses.*

(iii) *Automatic Circuit Breaker.* It is used to protect the testing apparatus from damage in case of failure of supply. It is provided with a no volt coil so that it automatically trips if the supply goes off.

(iv) *Over-voltage relay.* It is used to protect the apparatus from the effects of over voltages. This relay short circuits the no volt coil of the circuit breaker in case of over voltage and therefore the latter trips automatically isolating the apparatus from the supply.

(v) *Interlocks.* The interlocking arrangements are used :

(a) to ensure that the primary winding of h.v. testing transformer is switched on to a low voltage.

(b) to make it impossible for the operator to enter the h.v. testing enclosure while the supply is on. This is in the form of a gate switch. The supply to the primary winding of h.v. testing transformer is through a gate operated switch. When the gate is open, the switch is off and therefore the operator can safely go inside the enclosure.

(iv) *Earthing.* All the metal parts which should be at earth potential must be earthed. This includes transformer tanks, metal frame work of switchgear, enclosure and one end of each transformer winding.

The protective devices on the high voltage side of the test transformer are :

(i) *Protective Resistances.* When the specimen under test or sphere gap breaks down, voltage surges are produced. In order to protect the high voltage transformer from the effects of these surges a high resistance or a choke is connected in series with the secondary winding of h.v. transformer. The resistance is about $\frac{1}{2}$ ohm per volt.

(ii) *Sphere Gaps.* A sphere gap is connected across the high voltage transformer. In case of over voltage, the sphere gap breaks down and thus bypasses the surge. In order to prevent pitting of sphere gaps, a resistance is used to limit the current at breakdown. This resistance is about 1 ohm per volt so that the current is limited to 1 ampere at breakdown.

Corona. This is a phenomenon which occurs when the voltage gradient at the surface of a high voltage conductor exceeds the breakdown strength of air. This results in ionization of surrounding air accompanied by a faint glow and hissing sound.

Corona results in power loss and distortion of waveform. Thus it influences the breakdown and flashover voltages on account of surges in the circuit and because of presence of ionized air in the test room.

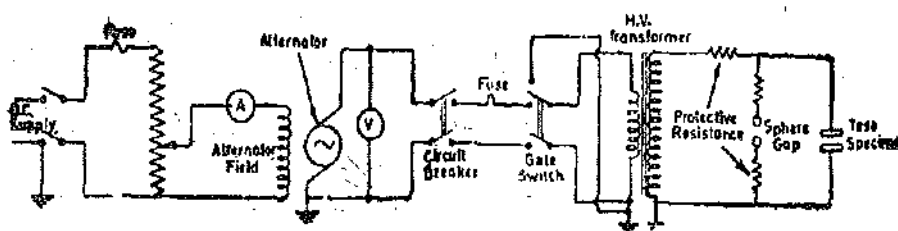

Fig. 17.11. Circuit for h.v. test-

Steps should be taken to eliminate corona as far as possible. Since the voltage gradient at the surface decreases as the diameter increases, the conductors used in high voltage circuits should be made much more larger in size than is necessitated by current carrying considerations. Also care should be taken to avoid sharp bends and small radii of curvature.

Fig. 17-11 shows a simple diagram of connections of a high voltage testing set up using a separate alternator.

17-12. Equipment for Voltage Measurement. The high voltages encountered in practice involve a large range of frequencies extending from zero in the case of d.c. to very high frequencies of surges caused by lightning. Most methods of measurement of high voltages described in the following pages are suitable for measurement at comparatively low frequencies. However, some of them give satisfactory results even for surge frequencies.

The methods of measurement of voltage are divided into two categories :

(i) Methods used for measurement of rms values of voltage.

We are interested in measurement of rms values of voltage because not only they have a direct bearing on the dielectric losses, but through internal heating they have a close connection with dielectric constant also.

(ii) Methods of measurement of peak values of voltage.

The measurement of peak values of voltage is also necessary because of the fact that the actual breakdown or flashover of the specimen under test is dependent upon the peak value of the applied voltage.

16-13. Measurement of R.M.S. Values of Voltage

1. Electrostatic Voltmeters. These instruments have been described in details in chapter 8 (page 254).

The following instruments may be used for measuring rms values of high voltages :

2. Attracted Disc Voltmeter. At high voltages, the design of the attracted disc voltmeter becomes difficult. A large spacing between plates is necessary in order to avoid flashover and corona.

The simple expression for voltage given by Eqn. 8-87 (page 260) does not hold good and corrections have to be applied.

In order to overcome the above difficulty, an absolute high voltage attracted disc voltmeter has been evolved by making use of gas at high pressure, or a high vacuum, in the region between plates. Both the designs made it possible to reach high field intensities than with air at atmospheric pressure; consequently the spacing between the plates can be decreased with no resultant side effects.

In high vacuum, for example, a voltage difference of 300 kV requires a spacing of only 3 cm. At the same time, however, the small spacing reduces the tolerances in flatness and parallelism of the plates. Moreover the attracted electrode needs close adjustment to the plane of guard ring.

Another method of improving the uniformity of the field is to insert, between the main plates, a series of intermediate electrodes. A capacitance divider, thus formed, preserves a uniform distribution of voltage between plates.

An inherent feature of these instruments is the tendency for the electrostatic force to make the disc unstable so that an adequate elastic or electromagnetic force trying to keep the disc in coplanar position is necessary. Also when alternating voltages are being measured, care must be exercised to ensure that the forced vibrations due to pulsating component of force, are minimized.

The electrostatic force is usually balanced by an opposing gravitational or electromagnetic force. The lack of balance can be detected by the displacement of the disc from its coplanar position and therefore very sensitive methods of measuring displacement are required in order to achieve a high degree of accuracy. Automatic adjustment of balance can be done through a servo-loop, the actuating signal is obtained from the output of the displacement detector. A disc may be loaded with a weight of approximately 90 g, or alternatively 360 g, corresponding to the attractive forces on the disc at electrostatic stresses of 5 kV/mm and 10 kV/mm. and a servo-system adjusts the electrode spacing

till the appropriate stress is obtained. The voltage is then read directly from a micrometer scale which indicates the spacing between the electrodes.

Alternatively, with a given electrode spacing the servo-system can be arranged to adjust the current in a coil coupled to the disc. This current produces an electromagnetic force which balances the electrostatic force and in addition stabilizes the disc powerfully in the coplanar position. The electromagnetic system is gravitationally calibrated.

3. Attracted Sphere Voltmeter. The tremendous classical theoretical analysis of the electrostatic field between two spherical electrodes has led to the development of Attracted Sphere Voltmeters. The voltage measurement is based upon measurement of electrostatic force between two spheres. A wide variety of sphere voltmeters have been produced wherein forces amounting to 4.2 to 7.5 N are produced with direct voltages which will flash over gaps of 100 mm and 500 mm between spheres of 1 m diameter.

The attractive forces between the spheres can be measured with a stiff elastic support. The errors involved are less than 1% for voltages as high as 1 MV.

Another method of measuring the electrostatic force is to observe the change produced in the period of oscillation of one of the spheres, swinging over a small arc. The voltage is proportional to

$$\sqrt{f_v^2 - f_0^2}$$

where f_v = oscillating frequency with applied voltage,
and f_0 = oscillating frequency without applied voltage.

The values of f_v and f_0 do not differ greatly as the restoring force is gravitational in nature. However, by using a rigid pendulum, the mass of the sphere can be counter-balanced. The value of f_0 is, therefore, reduced nearly to zero so that frequency of oscillations, f_v , is approximately proportional to the applied voltage.

4. Oscillating Ellipsoid Voltmeter. This is another system from which the attractive force between two electrodes can be obtained with a high degree of accuracy from the period of oscillation of an electrode.

The voltage to be measured is applied to a pair of discharge free parallel plate pair of electrodes lying in vertical planes and a small conducting electrode of accurate prolate spheroidal shape is suspended at its mid-point by a long unspun silk thread so that it hangs in the uniform field between the central parts of the plates with its long axis horizontal. When a voltage is applied an electrostatic field is produced due to which charges of opposite polarity and of calculable magnitude accumulate on the two ends of the ellipsoid. The ellipsoid, therefore, tends to align its long axis along the direction of the field. The ellipsoid oscillates about its final position on account of the moment of inertia. The controlling torque produced by the silk thread is very small. Therefore frequency of oscillations is approximately proportional to the applied voltage. The constant of proportionality can be calculated from the mass and dimensions of the ellipsoid and the geometry of the plate electrodes.

The disadvantage of the ellipsoid voltmeter is that the average electrostatic stress is much smaller than that which can be obtained when either attracted disc or attracted sphere voltmeters are used. This is on account of the concentration of the stress at the tips of the ellipsoid.

5. Transformer Ratio Method. In this method the primary voltage of the high voltage testing transformer is measured with a low voltage voltmeter (Fig. 17.12) and the secondary voltage is obtained as :

$$V_s = nV_p$$

where V_s = terminal voltage of secondary winding,
 V_p = terminal voltage of primary winding,
 n = turns ratio.

This method assumes that the ratio of transformation remains the same ($=n$) irrespective of the load and power factor on the secondary side. Owing to this reason, the method though simple, gives wrong results.

In some high voltage transformers, a separate voltage coil is provided whose voltage is measured with the help of a low voltage voltmeter. The secondary voltage in this case is given by :

$$V_s = \frac{N_s}{N_c} \cdot V_c$$

where N_s = number of turns of the secondary winding, and V_c = voltage across the coil.
 N_c = number of turns of the coil,

This method cannot be used for cascade arrangement of transformers. It gives an accuracy of 1 to 2 percent.

The advantage of this system lies in its convenience as a means of taking continuous reading after being calibrated by comparison with one of the direct systems of measurements.

6. Potential Divider Methods. In this method a potential divider is connected across the secondary winding (high voltage winding) of high voltage testing transformer and a definite fraction of secondary voltage is measured by a low voltage electrostatic voltmeter. A C.R.O. is used to obtain records of peak values of surge voltages.

Two types of potential divider arrangements are used :

- (i) Resistance potential divider, and (ii) Capacitance potential divider.

Both these potential divider methods have been described in Chapter 8. (See Art. 8'65 page 263).

We should use these methods only when either :

(a) the connection of the low voltage voltmeter has negligible effect on the voltage distribution, or

(b) appropriate allowance for low voltage voltmeter impedance is made in computing the potential divider ratio.

(i) **Resistance Potential Divider.** Upto about 10 kV an electrostatic voltmeter can be used successfully with an unshielded resistance potential divider with resistance units wound on flat insulating sheets.

However for voltages above 10 kV, resistance potential divider requires careful electrostatic shielding to minimise stray capacitance effects. For ideal shielding each point on the resistance should be shielded at its own potential, but in practice it is possible only to divide the total resistance into a number of equal sections each at its average potential. Fig. 17'13 shows an arrangement where the shield potentials are correctly maintained by an auxiliary potential divider.

(ii) **Capacitance Potential Divider.** This arrangement is shown in Fig. 17'14. In this method an electrostatic voltmeter having a capacitance C_0 is connected in parallel with a capacitor C_2 and the combination is connected in series with a standard capacitor C_1 across the high voltage winding of testing transformer :

Let V_s = voltage of the h.v. winding, and v = voltage across the voltmeter.

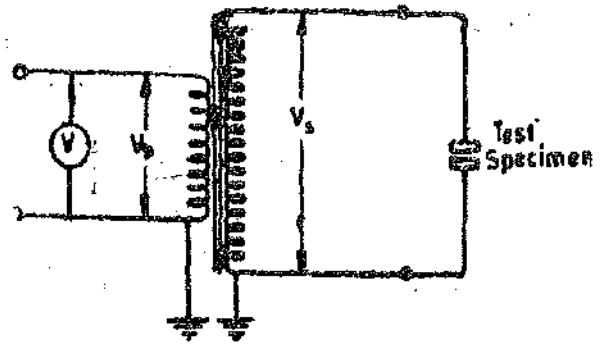

Fig. 17'12. Measurement of rms voltage by transformer ratio method.

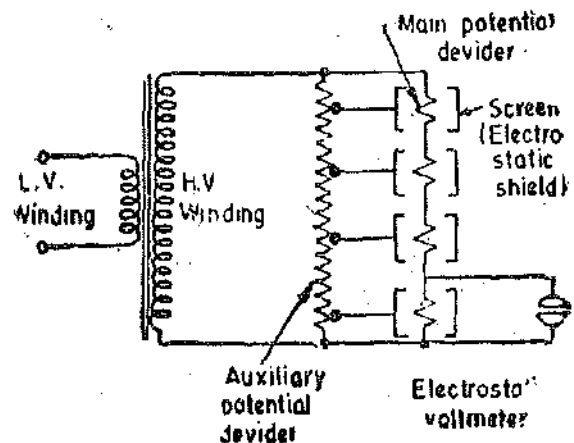

Fig. 17'13. Resistance potential divider.

$$V_s = \frac{C_1 + C_2 + C_v}{C_1} \cdot v$$

Now if C_2 is very large as compared to C_v ,

$$\therefore V_s = \frac{C_1 + C_v}{C_1} \cdot v$$

Since the capacitance C_v of voltmeter varies with deflection therefore the capacitance C_2 of capacitor which shunts the voltmeter is made large in order that the effects of variation of capacitance of voltmeter are swamped as is clear from the above expression.

The use of capacitance potential divider as compared to resistance potential for use at high voltages has the following advantages :

- (i) They are simple in construction.
- (ii) They are free from heating effects.
- (iii) They are comparatively free from effects of stray magnetic fields and can be easily shunted.

Capacitance of standard capacitor should be accurately known and the capacitor should be free from dielectric loss. Air capacitors are usually used with capacitances ranging from 50 pF to 100 pF.

(iii) **Compensated Capacitance Potential Dividers.** For any particular frequency a capacitance potential divider should have a ratio and phase angle independent of the load connected on the

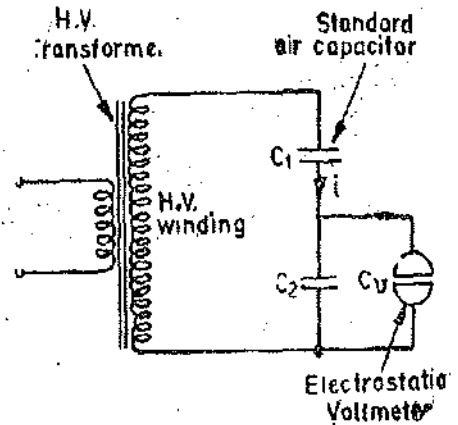

Fig. 17-14. Capacitance potential divider.

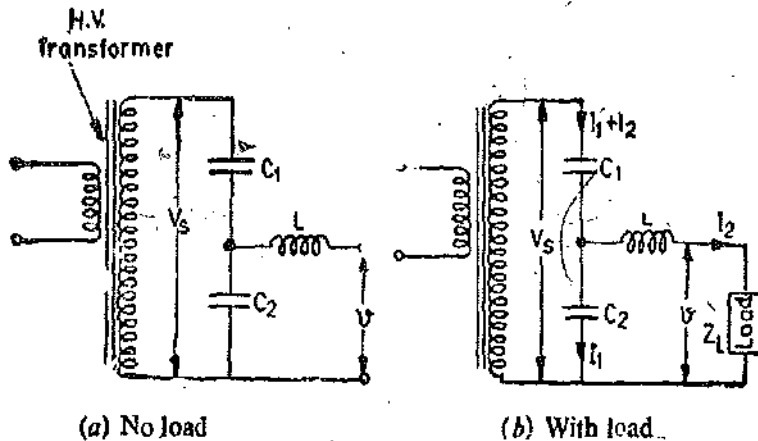

Fig. 17-15. Compensation for constant voltage ratio irrespective of load.

secondary side. This is achieved by connecting an inductance L in series with the load as shown in Fig. 17-15.

(a) **No Load Conditions.** Fig. 17-15 (a) represents the no load conditions and the voltage ratio is

$$\frac{V_s}{v} = \frac{C_1 + C_2}{C_1}$$

Suppose Z_L is the impedance of the load connected on the secondary side [Fig. 17-15 (b)]. The requirement that transformation ratio V_s/v remains the same irrespective of the load on the secondary winding the value of inductance L should be such that it gives resonance with C_1 and C_2 in parallel.

or
$$\omega^2 L = \frac{1}{C_1 + C_2}$$

This is explained as under :

At load,
$$V_s = \frac{j(I_1 + I_2)}{\omega C_1} - \frac{jI_1}{\omega C_2}$$

$$\text{Voltage across load } v = V_s - \left[\frac{-j(I_1 + I_2)}{\omega C_1} + j\omega I_2 L \right] = -j \left[\frac{I_1}{\omega C_2} + j\omega I_2 L \right]$$

$$\therefore \text{Voltage ratio } \frac{V_s}{v} = \frac{-j \left[\left(\frac{I_1 + I_2}{\omega C_1} \right) + \frac{I_1}{\omega C_2} \right]}{-j \left[\frac{I_1}{\omega C_2} + j\omega I_2 L \right]} = \frac{I_1(C_1 + C_2) + I_2 C_2}{C_1 \left[\frac{I_1}{C_2} + I_2 \omega^2 L \right]}$$

$$\text{Substituting } \omega^2 L = \frac{1}{C_1 + C_2},$$

$$\text{we have } \frac{V_s}{v} = \frac{[I_1(C_1 + C_2) + I_2 C_2](C_1 + C_2)}{C_1 [I_1(C_1 + C_2) + I_2 C_2]} = \frac{C_1 + C_2}{C_1}$$

$$\text{or voltage ratio } \frac{V_s}{v} = \frac{C_1 + C_2}{C_1}$$

This is the same value of ratio as we obtain on no load.

6. Standard Impedance Methods. A standard high impedance is connected across the terminals of the high voltage winding. The impedance may be standard air capacitor or a high resistance. The current flowing through the impedance may be measured by a thermocouple ammeter; (Fig. 17.16) by measuring voltage across a known resistance; using an electrostatic voltmeter or by using a valve voltmeter.

Secondary voltage $V_s = i \times Z$ where $Z =$ impedance connected across the h.v. winding terminals.

The impedance may be a series resistor. Series resistors are used in conjunction with moving coil, moving iron or electro-dynamometer milliammeters for measurements of voltages upto 100 kV. Moving coil instrument is useful for d.c. only while the others are used for measurement of rms values of a.c. voltages.

7. Potential Transformer Methods. Modern potential transformers have accuracies comparable with those of good potential dividers. In comparison with potential dividers they have the advantages that :

(i) the indicating instrument is isolated from the high voltage circuit ;

(ii) within limits, the instrument impedance has negligible effect on the ratio of transformation.

For measurement of very high voltages two stage reduction by means of a combination of a potential divider and potential transformer proves very useful.

Potential transformers may be used with electro-dynamometer, moving iron, or electrostatic instruments for measurement of rms values of a.c. voltages upto 200 kV.

The range may be extended by capacitor potential transformer (see Art. 9.24 page 318).

17.16. Measurement of Peak Values of Voltages.

1. Transformer Ratio Method. The measurement of rms value of voltage with this method has already been explained. In order that the peak value of secondary voltage be measured, we must determine the secondary voltage waveform. From the voltage waveform the crest factor is evaluated.

$$\text{Crest factor} = \frac{\text{peak voltage}}{\text{rms voltage}}$$

or Peak voltage of secondary winding $V_{ms} = \text{crest factor} \times nV_p$.

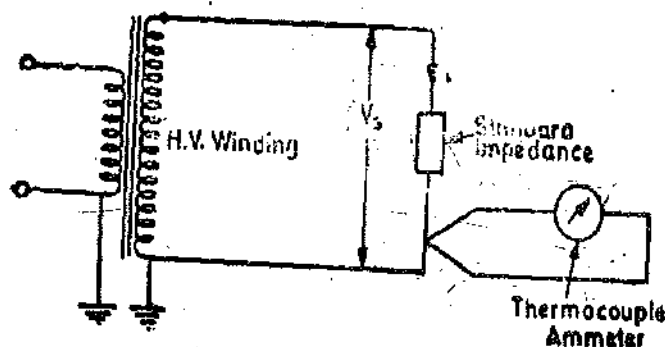

Fig. 17.16. Measurement of voltage by standard impedance method.

where
and

V_p = rms voltage of primary winding.

n = ratio of secondary to primary winding turns.

2. **Sphere Gaps.** The breakdown voltage of a spark gap between two metal spheres may be used as a measure of voltages upto the highest encountered in high voltage testing. The normal arrangement consists of two equal sized, polished aluminium or (aluminium alloy) spheres separated by an air gap. The spheres are usually mounted vertically one above the other, with the lower sphere earthed. The arrangement for voltage measurement with sphere gaps is shown in Fig. 17'17. The voltage between the spheres is raised till a spark passes between the two spheres. The value of voltage required to spark over (breakdown) depends upon the dielectric strength of air, the size of spheres, the distance between the spheres and many other factors.

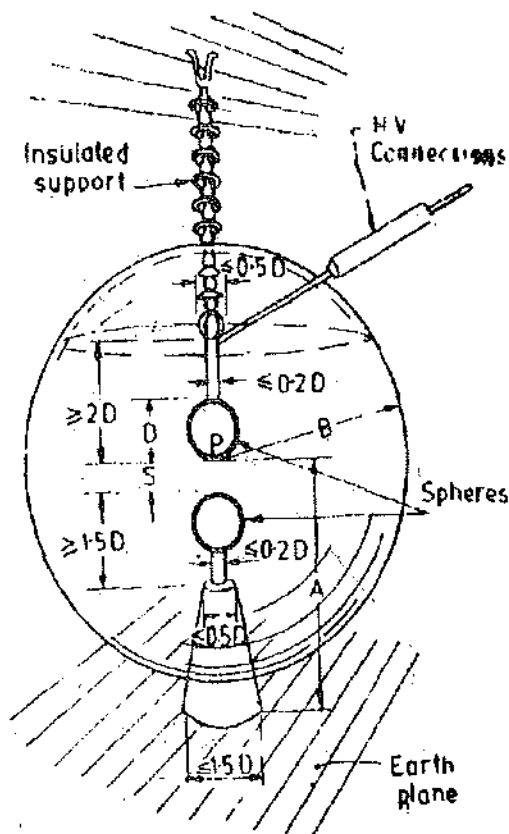

Typical vertical sphere-gap, S, showing limiting dimensions of components and clearances.

D = sphere gap diameter

P = sparking point of H.V. sphere,

A = Distance of P to earth plane,

B = radius of space around P free from external structures.

Fig. 17'17. Measurement of voltage with sphere gaps.

Calibration tables have been compiled on the basis of experimental work with different sizes of spheres, different gap lengths at specified conditions of pressure and temperature. The breakdown voltages corresponding to actual working conditions may be directly read off from the calibration tables. However, corrections must be applied for temperature and pressure conditions.

These calibration tables give the rms values of sparkover voltages. To obtain peak voltages from results given in the tables the rms values must be multiplied by $\sqrt{2}$.

Advantages

(i) The sphere gaps may be conveniently used for determination of peak value of a voltage wave. Their main use is for calibration of voltmeters and voltage measuring devices for high voltage tests.

(ii) The method is simple and peak voltages may be measured from about 2 to 2500 kV by getting a spark over and then referring to the calibration tables.

(iii) Sphere gaps may also be used for measurement of voltage in surge (impulse) tests.

(iv) Method of voltage measurement with sphere gaps is cheap, simple and reliable.

Disadvantages

(i) The sphere gaps do not give a continuous record of voltage.

(ii) Voltage measurements carried out by sphere gaps can be relied upon to be accurate within 2–3% provided suitable precautions are taken. This is not a high accuracy in comparison with other electrical measurements. However even this accuracy is acceptable owing to difficult conditions of working in high voltage testing

Precautions

(i) Ionization of air gap depresses the spark over voltage and therefore ultra-violet or other ionization radiation should be avoided. However, in high frequency work this small ionization has an advantage and this may be provided by mild corona on high voltage cables or from a remote source of ultra-violet radiation.

(ii) In order to avoid pitting of spheres, a current limiting resistance of 1 ohm per volt may be inserted in the sphere gap circuit.

(iii) After testing, the spheres should be properly cleaned to remove any extraneous matter.

(iv) The spheres should not be highly polished.

(v) No conductor or body having a conducting surface (except the supporting shanks) shall be near the sparking-point of the h.v. sphere than the distance given by the expression $0.25 + V/300$ m where V is the voltage in kV (peak) which is to be measured.

(vi) The time interval between consecutive flash overs should be large enough to avoid appreciable heating of spheres.

3. Rectified Capacitor Charging Current Method. This method depends upon the fact that the average charging current of a standard air capacitor is proportional to the peak voltage. This charging current is rectified and its average value is then measured by a permanent magnet moving coil milliammeter or a d'Arsonval galvanometer.

Fig. 17-18 shows the circuit for measurement of peak voltage. C is a high voltage compressed gas capacitor across which practically whole of the high voltage is dropped. Specially designed rectifiers may be used for the rectification of alternating currents. A is the milliammeter for measurement of average charging current.

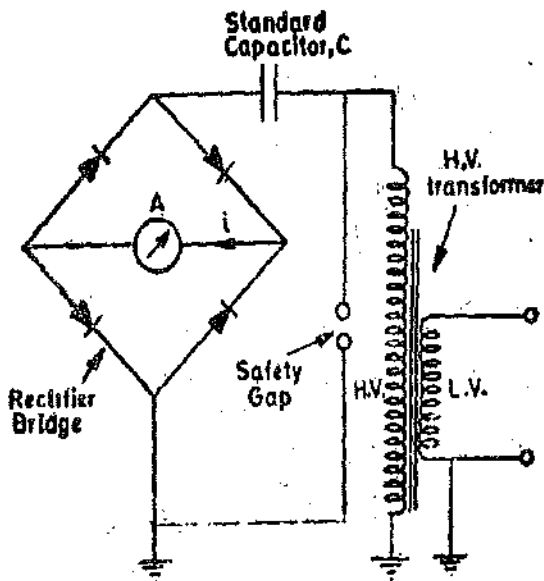

Fig. 17-18. Rectified capacitor charging current method.

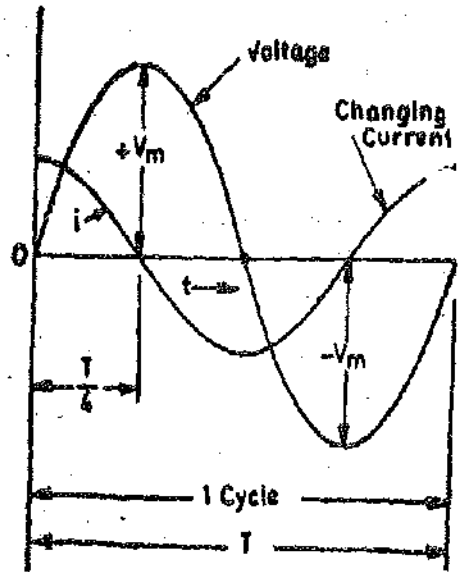

Fig 17-19

Theory. Suppose the impedance of rectifier is negligible as compared with that of capacitor. Therefore the impedance offered to the path of current is on account of capacitor only and thus the charging current leads the applied voltage by 90° . Let v be the voltage at any instant. $\therefore v = V_m \sin \omega t$, where V_m is the peak voltage.

Charging current at any instant $i = \frac{V_m}{1/\omega C} \sin (\omega t + \pi/2) = V_m \omega C \cos \omega t$

Referring to Fig. 17-19.

Average charging current

$$I_{av} = \frac{1}{T/4} \int_0^{T/4} V_m \omega C \cos \omega t \, dt = 4 V_m f C \quad \left(\because T = \frac{1}{f} \right)$$

Thus $V_m = \frac{I_{av}}{4Cf}$... (17.1)

Eqn. 17.1 gives the value of peak voltage if the value of capacitance and frequency is known.

The method is accurate for sine waves provided that the impedance of the rectifier is negligibly small as compared with that of the capacitor.

The method is satisfactory for all waveshapes with the exception of :

- (i) waveshapes with different positive and negative maxima,
and (ii) waveshapes with more than one-peak in each half cycle.

Example 17.1. A permanent magnet moving coil ammeter indicates 20 mA when connected to opposite corners of a bridge rectifier. The other two corners of the bridge rectifier are connected to a secondary of a 50 Hz high voltage transformer through a 707 pF capacitor. Calculate the peak value of the voltage assuming it to be sinusoidal.

Solution. From Eqn. 17.1, peak voltage of secondary of h.v. transformer

$$V_m = \frac{I_{av}}{4Cf} = \frac{20 \times 10^{-3}}{4 \times 707 \times 10^{-12} \times 50} \text{ V} = \sqrt{2} \times 100 \text{ kV}$$

4. Ryall Crest Voltmeter. Fig. 17.20 shows a simplified arrangement of measuring Crest (Peak) voltage with Ryall Crest Voltmeter. It consists of two capacitors C_1 and C_2 connected in series across the high voltage winding of the test transformer. Capacitor C_1 is variable while C_2 is fixed. The capacitance of variable capacitor C_1 is very large as compared to that of C_2 with the result that almost the entire voltage is across capacitor C_2 .

A neon lamp of special type is connected across the variable capacitor C_1 . Neon lamps have the property that they commence to glow when the voltage applied to them reaches a definite value called a.c. striking voltage.

In this method the capacitance of capacitor C_1 is gradually reduced so that there is an increased voltage across it. This voltage is increased until the lamp strikes. Then the peak voltage is given by :

$$V_m = V_{act} \left(1 + \frac{C_1}{C_2} \right), \quad \text{where } V_{act} = \text{a.c. striking voltage of the neon lamp.}$$

This voltmeter has the advantage that its indication is independent of the frequency. It can be designed to read up to 150 kV.

5. Ionic Wind Voltmeter. The principle on which this voltmeter works is given below : When the stress at a highly charged electrode in a given gas exceeds the ionization value, the ions so produced are repelled by high intensity field. During their movement the ions collide with the uncharged molecules and set them in motion away from the point, giving rise to an ionic wind.

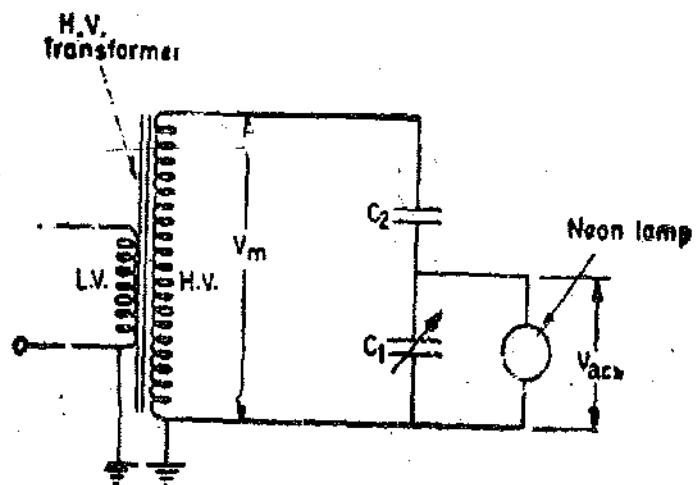

Fig. 17.20. Ryall Crest voltmeter.

Fig. 17.21 (a) shows the set up of the voltmeter. A hot wire, of platinum-gold alloy is

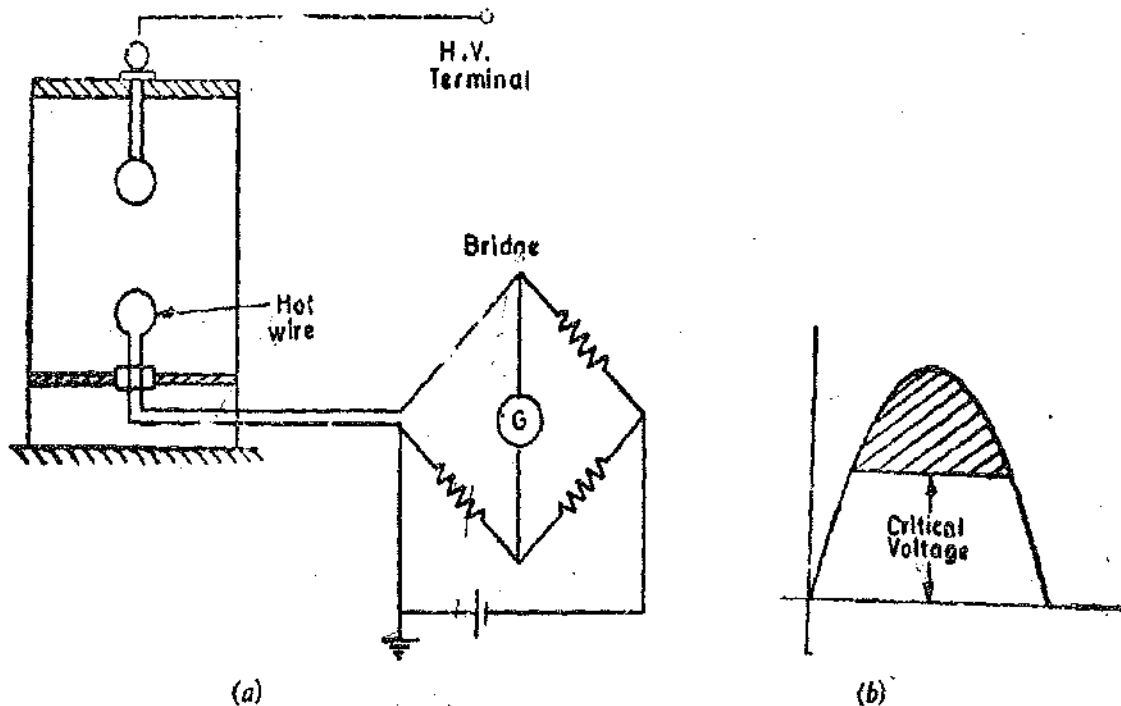

Fig. 17.21. Ionic wind voltmeter.

included in one arm of the Wheatstone bridge. This wire also forms the earthed electrode of the voltmeter. The bridge network is balanced initially. The high voltage to be measured is applied to the voltmeter and this starts an ionic wind which is directed on to the hot wire. The hot wire cools and therefore its resistance changes. This causes an appreciable out of balance voltage to appear in the bridge network and this is indicated by the galvanometer. The cooling and hence the galvanometer deflection depends upon the potential gradient (applied voltage), the temperature of the electrode, the nature and pressure of the gas and upon the frequency.

Apart from a small initial cooling effect due to convection the main cooling action starts when the potential gradient rises above a critical value. Thus peak voltage of the measured supply must exceed the critical voltage for part of a cycle before an indication is obtained. The part of the cycle where voltage is more than the critical is only effective in the cooling [see Fig. 16.20 (b)]. It follows that the instrument is not a true peak voltmeter and a knowledge of waveform is essential in order to determine the value of peak voltage.

The principal advantages of this voltmeter are :

- (i) The high voltage may be measured by an observer at some distance from the charged conductor.
- (ii) It is robust in construction.
- (iii) Its indications are free from disturbances, weather and temperature conditions. So it can be used for outdoor work also. These voltmeters are used upto 300 kV.

17.17. Measurement of D.C. Voltages. Most of the methods described in the preceding paragraphs are suitable for measurement on high voltage d.c. and a.c. systems but for one or two exceptions. The methods employing capacitance potential dividers or the capacitor charging current method cannot be used for d.c. measurements.

Resistance potential dividers can be used. The series resistance method is also satisfactory when a high resistance is used in series with a current operated d.c. instrument.

17.18. Measurement of Instantaneous Voltage. High voltage cathode ray oscilloscope, with suitable potential divider where necessary is used for measurement of instantaneous values. A treatment of cathode ray oscilloscope is given in Chapter 21

17.19. Low Frequency H.V. Tests. Fig. 17.22 shows the arrangement for sustained low frequency H.V. testing.

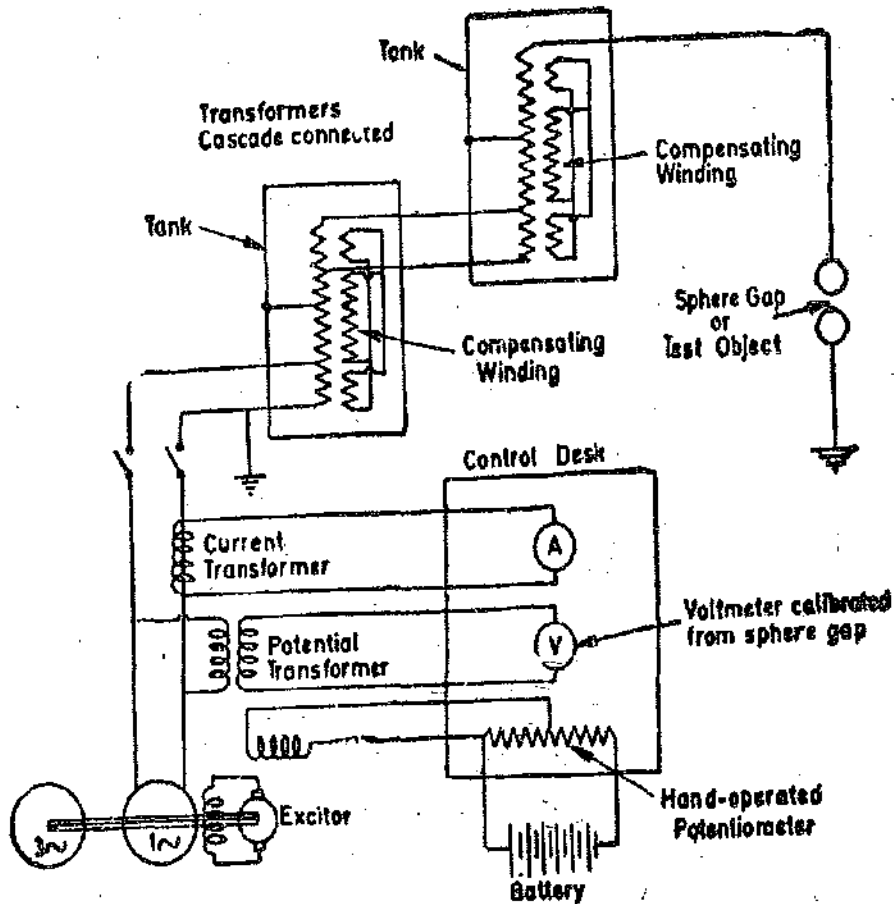

Fig. 17.22. Sustained low frequency high voltage testing.

17.20. High Voltage D.C. Testing. In addition to the equipment required for low frequency tests, a source for generation of d.c. is required for high voltage d.c. testing.

Generation of d.c. at high voltage by rotating electrical machines is not possible owing to limitations imposed by commutator and commutation conditions. Therefore high voltage d.c. is always obtained by rectification of alternating currents. Electronic oscillators working at 30–100 kHz may be used to feed the rectifiers upto a voltage of 50 kV as use of high frequency a.c. reduces the size of high voltage transformer. But there are some extra complications with use of high frequencies and therefore normally alternators are used to supply power at 50 Hz which is converted into d.c. by rectifiers.

The rectifying circuits commonly used are shown in Figs. 17.23 to 17.26.

For the sake of clarity many essential parts of the rectifying equipment like smoothing circuits, protective resistors to limit the current during breakdown of test specimen have not been shown.

Fig. 17.23 shows a single phase half wave circuit. Fig. 17.24 shows a bi-phase half wave circuit. Fig. 17.25 shows a full wave circuit. Fig. 17.26 shows a voltage doubler circuit.

For high voltage working these circuits require many special constructional features particularly with regards to the insulation problem.

In the circuits shown the capacitor charges upto peak of the voltage applied across it. It is prevented from discharging through the transformer by the rectifier but can discharge through the load (which is represented by a resistance).

These circuits are used upto a voltage of 100 kV or more in some cases.

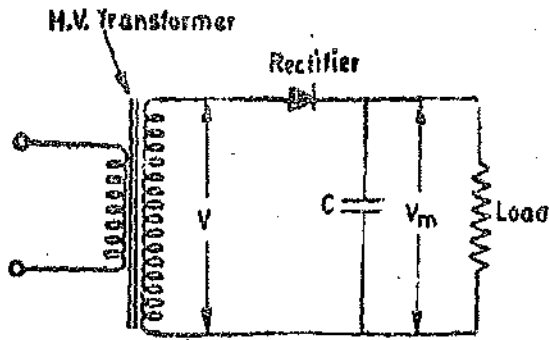

Fig. 17-23

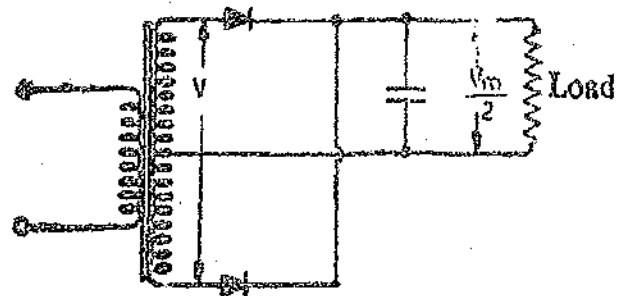

Fig. 17-24

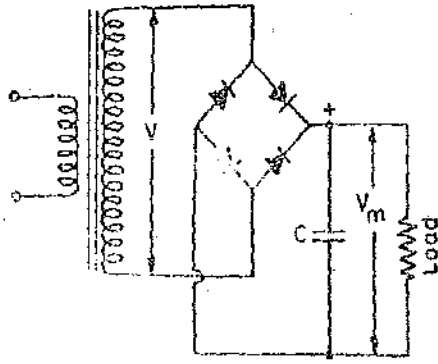

Fig. 17-25

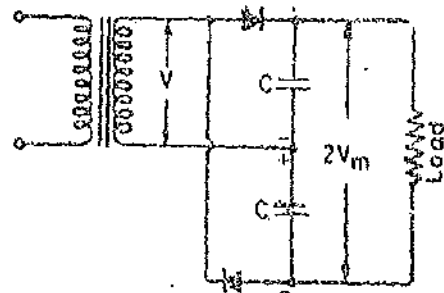

Fig. 17-26

Rectifying circuits.

17-21. **Cockcroft Walton Circuit.** This circuit is used to get very high voltage d.c. supply without using high voltage transformer of more than 100 kV rating.

Let us consider the circuit shown in Fig. 17-27 (a). The peak voltage on H.V. side of the high voltage transformer is V_m .

Therefore the rectifier charges the capacitor C_1 to a voltage $+V_m$. The voltage of the end 'a' of transformer winding varies between $+V_m$ and $-V_m$ with respect to earth and therefore the voltage of point A oscillates between 0 and $+2V_m$ with respect to earth E.

Now if we connect a capacitor C_2 as shown in Fig. 17-27 (b), this capacitor will be charged to a voltage $+2V_m$ through rectifier 2.

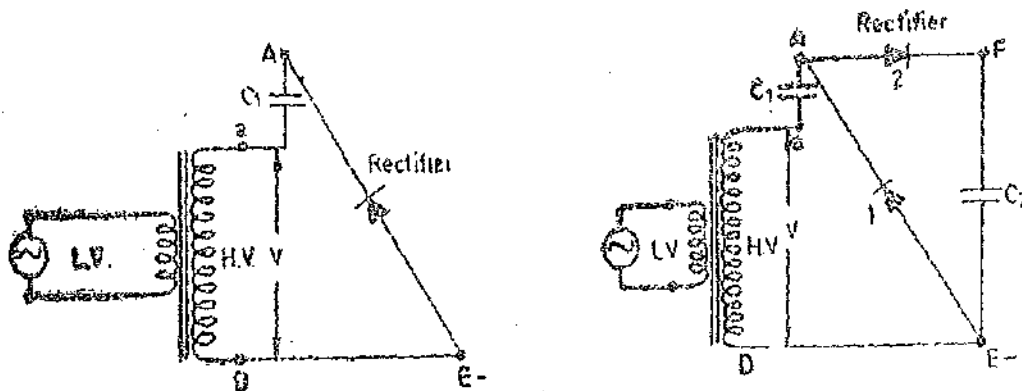

(a)

(b)

Fig. 17-27

The complete Cockcroft-Walton circuit is shown in Fig. 17-28. It is in fact a cascade connection. As the potential of A varies between zero and $+2V_m$, F being at a steady potential of $+2V_m$, the voltage applied to capacitor C_3 via rectifier 1 if C_3 were uncharged, would vary between zero and $+V_m$. Thus C_3 charges upto the peak of this voltage i.e., $+2V_m$. The potential of B

therefore oscillates between $+2V_m$ and $+4V_m$. This gives a voltage of $+2V_m$ across C_4 , as F is already at a potential of $+2V_m$. Thus C_4 charges to a steady potential of $2V_m$. The potential of G with respect to earth becomes $+4V_m$. The portion $BCHG$ of the circuit is a 3rd stage and output of the whole circuit is $+6V_m$. For an n stage circuit, the output voltage would be $+2nV_m$. Therefore if we go on adding stages, higher and higher voltages can be obtained.

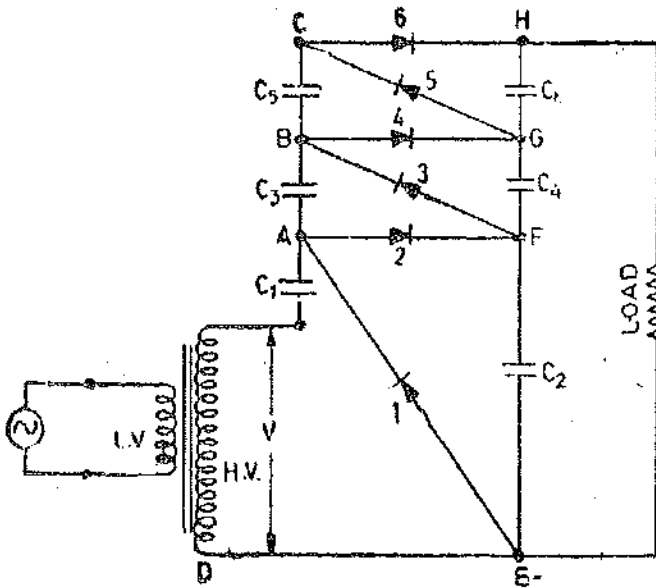

Fig. 17-28. Cockcroft Walton circuit.

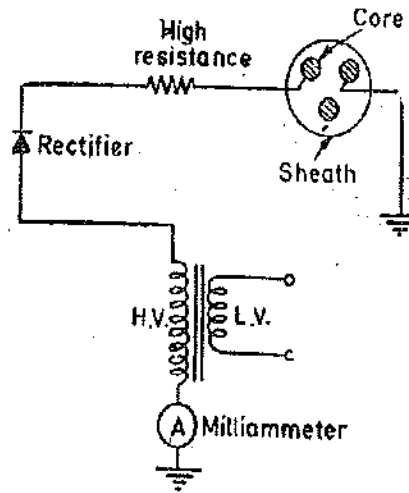

Fig. 17-29. High voltage d.c. test on 3 core cable.

17-22. High Voltage D.C. Testing of Cables. Fig. 17-29 shows a circuit for cable testing. Current passes for only one half wave of the cycle. During this time the capacitor formed by cable cores and sheath is charged to a potential V_m i.e., the peak voltage of secondary winding of h.v. transformer. During the next half cycle, the potential of this cable capacitor remains the same and the potential of the cathode rises to V_m in the other direction and therefore the rectifier must be designed to withstand a voltage of $2V_m$.

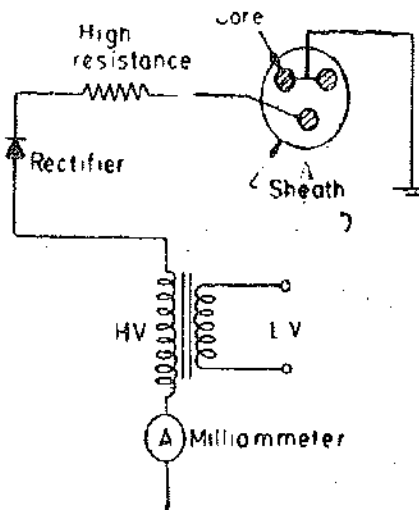

Fig. 17-30. High voltage d.c. test on 3 core cable.

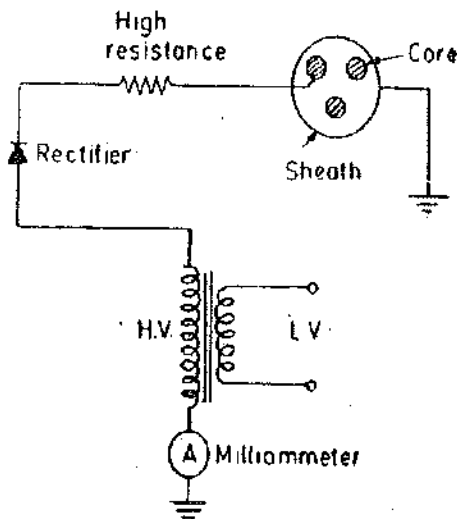

Fig. 17-31. High voltage d.c. test on 3 core cable.

The charging and leakage currents are indicated by a milliammeter as shown. A resistance of about $0.25 \text{ M } \Omega$ is connected in the anode circuit for protection against surge effects.

Three core cables are tested by two other connections as shown in Figs. 17-30 and 17-31. For tests upto 200 kV, two rectifiers are used.

Fig. 17'32 shows the connections for testing a 3-core cable with two rectifiers. A voltage of $2V_m$ is obtained between the cores, and V_m between cores and earth.

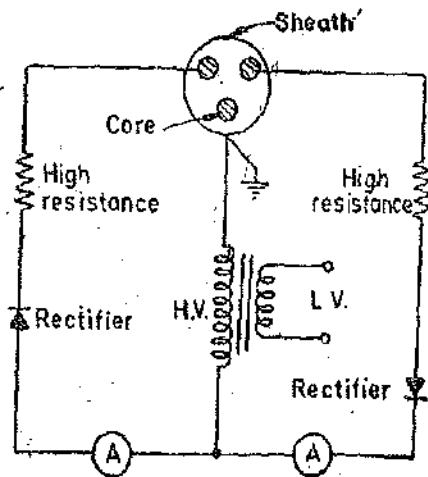

Fig. 17'32. High voltage d.c. test on cable upto 200 kV using 2 rectifiers.

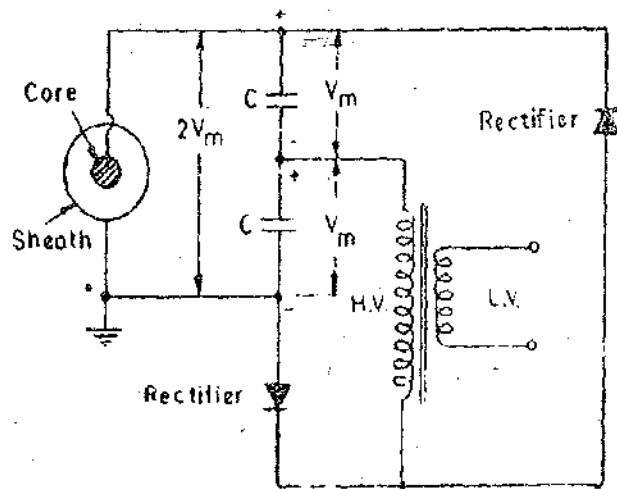

Fig. 17'33. High voltage d.c. test on cables using voltage doubler circuit.

For testing single core cable, a voltage doubler circuit is used as shown in Fig. 17'33. The cables are usually tested in the field and therefore these testing sets for field duty are made portable. A small engine driven alternator is used for supplying the l.v. winding of the high voltage testing transformer. The voltage regulation is done by an auto transformer and fine adjustments are done by a choke coil connected in series with the primary winding (l.v.) circuit. The voltage is measured with an electrostatic voltmeter. A sphere gap is also used alongside.

The testing circuit should be protected from voltage surges which cause breakdown of apparatus. Therefore care should be taken to increase the voltage gradually and to discharge the cable through a high resistance after the test. The discharging connection should be maintained for a considerably long period in order to avoid subsequent rise of voltage of cable which may result owing to dielectric absorption.

17'21. Equivalence of D.C. and A.C. Test Voltages. Owing to the "electric osmosis" effect, any moisture, which may exist within the cable dielectric, tends to move towards the negatively-charged electrode (the sheath or one of the cores, depending upon the test), when a d.c. voltage is applied. Although the amount of such moisture is usually small, it may yet be sufficient to cause breakdown due to its concentration near the negative electrode. If the applied voltage is alternating no such movement of moisture occurs, the moisture remaining uniformly distributed. Again, breakdown may occur when testing cable-samples due to surges which are produced by spark-discharge and corona effects at the cable ends. These effects are more severe with a.c. than with d.c.

For these reasons it is obvious that there are other considerations beyond mere equivalence of potential gradient which must determine to what alternating voltage a given direct voltage is equivalent from the point of view of insulation breakdown.

N.A. Allen gives a table showing the ratio of d.c. to a.c. test voltages, quoted by various authorities as giving an equivalent breakdown-test upon cables and dielectrics. For paper-insulated cables, although a d.c./a.c. ratio of 2.5 has been used, Allen suggests that a ratio of 1.5 to 2.0 would be more satisfactory. Owing to the fact, also, that this ratio increases with increasing insulation thickness, he suggests the adoption of a ratio 1.5 for cables upto 33 kV, and a ratio of about 2.0 for voltages above this. The following table gives the d.c./a.c. ratios usually adopted by cable makers.

Working Voltage	Standard test Voltage		Ratio D.C./A.C.	Average thickness of dielectric
	A.C.	D.C.		
11 kV	20 kV	30 kV	1.5	7.62 mm
22 kV	44 kV	75 kV	1.71	10.2 mm
33 kV	66 kV	100 kV	1.52	12.7 mm

17.22. **Localization of Faults in High Voltage Cables** The resistance presented by high-voltage cable under fault conditions is very high and therefore such faults cannot be located with accuracy by the methods already described in chapter 15. In high-voltage cables breakdown occurs

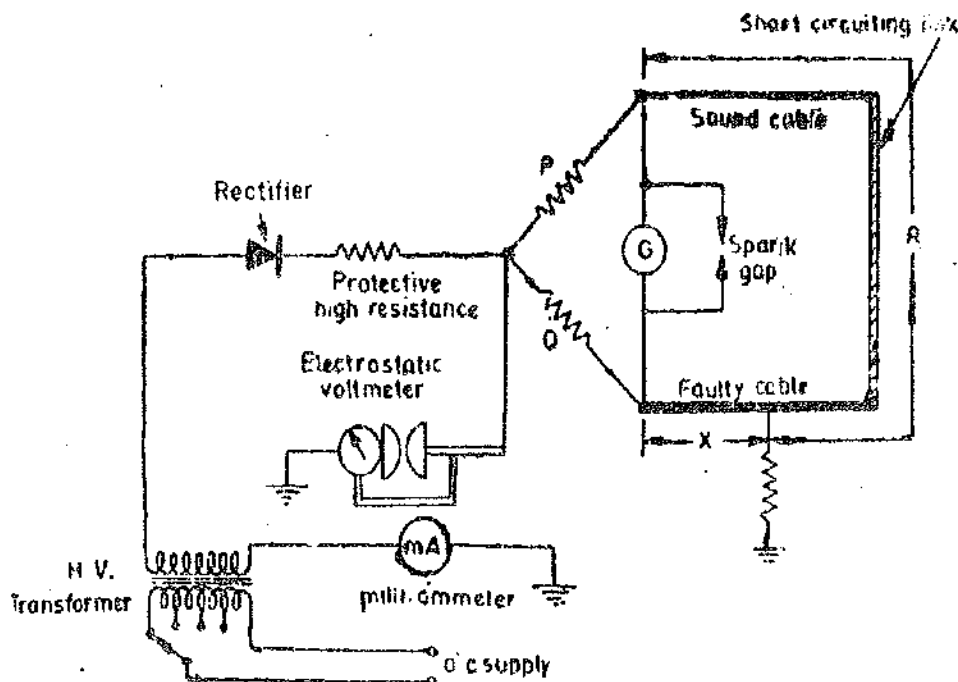

Fig. 17.34. Localisation of faults in high voltage cables.

at the time of application of the high voltage especially when the oil in the cable and cable joints breaks down and therefore presents a low resistance. However, when the applied voltage is withdrawn the oil recovers its insulating property and the cable again presents high insulation resistance. The fault resistance may be reduced by a continued application of the high voltage so as to carbonize (or burn out) the insulation at the point of the fault. After the insulation resistance is so reduced ; ordinary loop-test may then be applied to determine the position of the fault.

A more satisfactory method which is generally adopted is to perform the Murry loop-test at high voltage obtained from either half-wave or full-wave rectifier systems. Fig. 17.34 gives the circuit arrangement for localization of faults in high-voltage cables. The rectified supply at about

60 kV is obtained from a high-vacuum diode. A higher voltage, if desired, may be obtained with two valves. A step up high voltage transformer is used to feed the rectifier. A current limiting high resistance and a milliammeter are included in the supply circuit for the limitation and measurement of the fault current. An electrostatic voltmeter is used to measure the voltage at the junction point of the ratio arms. A loop is made connecting together the faulty and sound cables with the help of a short circuiting link. For varying the ratio arms (P, Q) a highly insulated slide-wire, having a sliding contact which can be operated by a long insulating handle is used. The spark gap is used for the protection of the galvanometer. The procedure adopted for the test is detailed below: The circuit is energised and the tap at the primary of the H.V. transformer is adjusted to give a low fault current of the order of 5 mA at the time of break down of the cable. The bridge is balanced by varying P/Q ratio. The tap of the primary of H.V. transformer is then changed to increase the fault current to about 50 mA. The bridge is rebalanced. It may be mentioned at the time of breakdown, a very large drop of voltage occurs across the protective high resistance and therefore the voltage across the cable is low. However, if the fault clears, the voltage across the cable would rise suddenly and it is on this account highly insulated slide-wire is used for the safety of the operator.

The position of the fault can be obtained using equations given for Murray loop test in chapter 15. (See Eqns. 15'1 and 15'2 pages 484 and 485).

17'23. High Frequency Tests. It has been explained earlier that the behaviour of insulating materials working at high frequencies is different from that at ordinary power frequencies. The difference is mainly due to increased dielectric loss at high frequencies. This dielectric loss produces internal heating with the result that the breakdown strength of insulating materials is lower at high frequencies. High frequency tests are also useful for detection of inhomogeneity in compound filled porcelain insulators. Two types of high frequency tests are done:

1. **Tests with Undamped High Frequency Oscillations.** These tests are done on porcelain insulators used for communication purposes. Undamped high frequencies are not encountered in power systems and the insulators used therein are not subjected to these tests.

Undamped high frequency voltages upto a frequency of 30 kHz may be produced by alternators. Arc generators can also be used for the purpose but they have the disadvantage that smooth voltage regulation is not possible.

Usually electronic circuits are used for production of high frequency high voltages. Equipment have been developed which give an output of 150 kV and a frequency of 100 kHz.

2. **Tests with Damped High Frequency Oscillations.** Fig. 17'35 shows a circuit for production

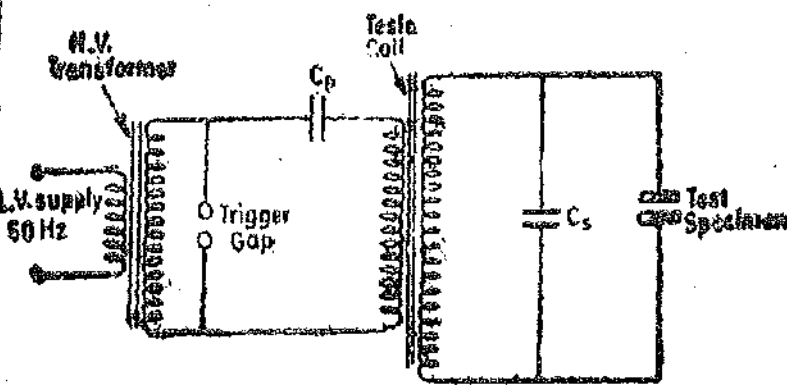

Fig. 17'35. High frequency high voltage testing.

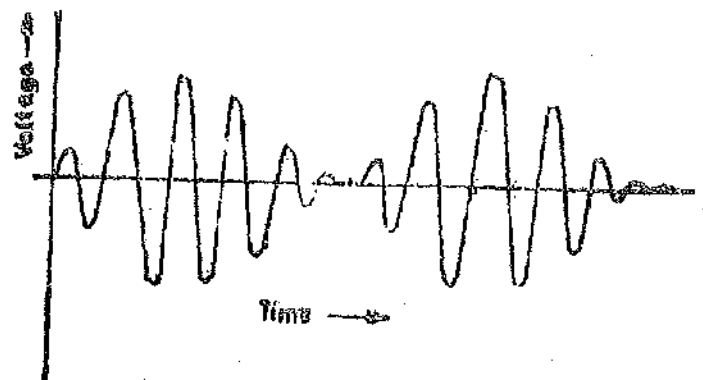

Fig. 17'36. Damped high frequency oscillations.

of high frequency damped oscillations. This circuit uses a Tesla coil which is in the form of a high voltage transformer. The capacitor C_p on the primary side is charged to a potential which causes a trigger gap to breakdown with the result that the capacitor discharges. Due to this discharge, a train of damped high frequency oscillations are produced in the circuit containing C_p , trigger gap and the primary of the Tesla coil. The charge and discharge of capacitor C_p takes place two times in one

voltage cycle. Therefore, there will be 100 trains of frequency oscillations (Fig. 17'36) in a second for a 50 Hz supply.

$$\text{The frequency of oscillations } f = \frac{1}{2\pi\sqrt{L_p C_p}}$$

This frequency is of the order of 100 kHz. The highest frequency from which any trouble can be expected in a transmission system is about 800 kHz and hence 100 kHz is the maximum frequency required for testing.

Since the primary winding of the Tesla coil carries an oscillatory current, oscillations are induced in the secondary winding. If the primary and secondary windings are tuned i.e., $L_p C_p = L_s C_s$ the frequency of oscillations in the secondary winding will be the same as in the primary.

These damped high frequency oscillations are impressed upon the test specimen as shown in Fig. 17'35.

A sphere gap is used for voltage measurement and a cathode ray oscilloscope may be used to record the waveform of secondary voltages of the Tesla coil.

17'24. Surge (Impulse) Testin~

Terms and Definitions :

1. **Impulse Voltage.** An impulse voltage is a unidirectional voltage which rises rapidly to its maximum value and falls more or less rapidly to zero. An impulse voltage is shown in Fig. 17'37.

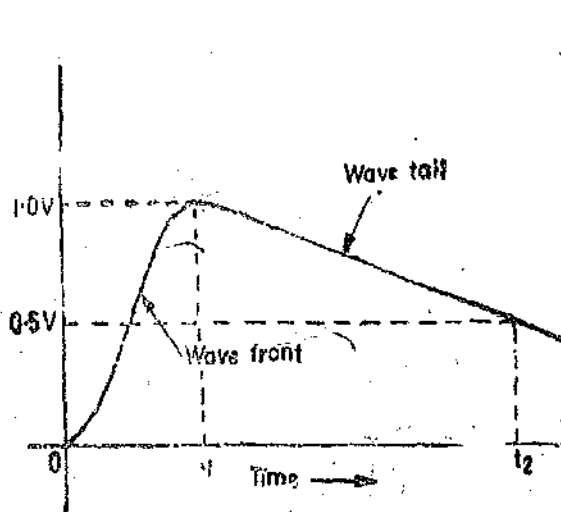

Fig. 17'37. Full surge wave.

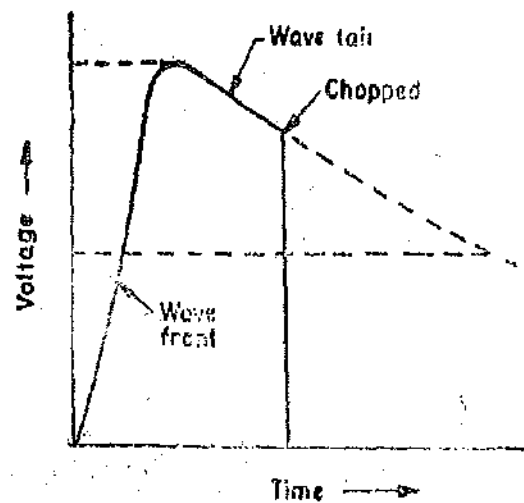

Fig. 17'38. Chopped surge wave.

If an impulse voltage develops without causing a flashover or puncture, it is called a full impulse voltage. However if a flashover or a puncture occurs, it is called a chopped impulse voltage (Fig. 17'38).

A full impulse voltage is characterized by two time intervals t_1 and t_2 defined below. The impulse voltage is conveniently expressed as a t_1/t_2 wave. Time interval t_1 is the time taken by the impulse voltage to rise to its peak value and t_2 is the time taken to fall to 50 percent of its peak value (See Fig. 17'37). Normally 1/50 μ s impulse voltages are used for testing. This voltage indicates that it rises to its peak value in 1 μ s and falls to 50 percent of its peak value in 50 μ s.

2. **Impulse Flashover Voltage. 50 per cent Impulse Flashover Voltage :** It is the peak value of that impulse voltage which causes flashover of the object under test for about half the number of applied impulses.

3. **Impulse Puncture Voltage.** The impulse puncture voltage is the peak value of that impulse voltage which causes the puncture of the specimen under test when puncture occurs on wave tail and is the value of the voltage at the instant of puncture when puncture occurs on the wavefront.

4. **Impulse Ratio for Flashover.** The impulse ratio for flashover is the ratio of impulse flashover voltage to the peak value of power frequency flashover voltage.

The impulse ratio for puncture can also be defined in a similar manner.

17.25. **Basic Impulse Generator Circuit.** Consider the case of a fundamental impulse generator as shown in Fig. 17.39 from which all impulse generators are derived. C is a capacitor charged from an independent d.c. source E , and discharged through inductance L and resistance R . The impulse voltage is developed across resistance R . The capacitor is charged to a voltage E and the switch S is closed and the capacitor discharges through R, L .

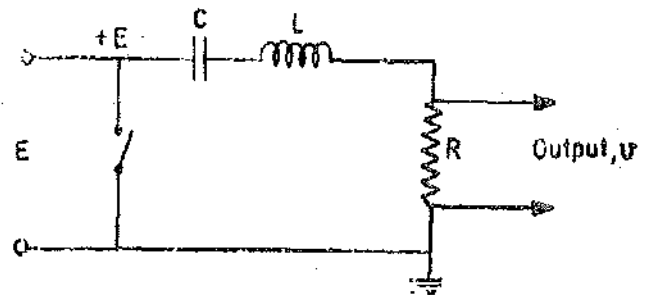

Fig. 17.39. Basic impulse generator circuit.

We will be using Heaviside's operational calculus for the analysis.

Voltage across resistance R is :

$$v = \frac{R}{R + pL + 1/pC} E1 = \frac{pCR}{p^2LC + pRC + 1} E1.$$

The solution of the above equation is : $v = \frac{M(0)}{N(0)} + \sum_{k=1, 2, \dots} \frac{M(p_k) e^{p_k t}}{p_k N'(p_k)}$

Now $M(p) = EpCR$, $\therefore M(0) = 0$, and $N(p) = p^2LC + pRC + 1$.

Differentiating $N(p)$ we have : $N'(p) = 2pLC + RC$.

The roots of equation $p^2LC + pRC + 1 = 0$

$$\text{are } p_1 = \frac{-RC + \sqrt{R^2C^2 - 4LC}}{2LC} = -\frac{R}{2L} + \sqrt{\frac{R^2}{4L^2} - \frac{1}{LC}} = -a + b$$

and $p_2 = -a - b$.

\therefore Voltage across resistance R .

$$\begin{aligned} v &= \frac{M(0)}{N(0)} + \sum_{k=1, 2} \frac{M(p_k) e^{p_k t}}{p_k N'(p_k)} = 0 + \frac{Ep_1 CRE^{p_1 t}}{p_1(2p_1LC + RC)} - \frac{Ep_2 CRE^{p_2 t}}{p_2(2p_2LC + RC)} \\ &= E \frac{R}{L} \left(\frac{e^{p_1 t}}{2p_1 + \frac{R}{L}} + \frac{e^{p_2 t}}{2p_2 + \frac{R}{L}} \right) = E \frac{R}{L} \left(\frac{e^{-(a-b)t}}{-2(a-b) + \frac{R}{L}} + \frac{e^{-(a+b)t}}{-2(a+b) + \frac{R}{L}} \right) \\ &= E \frac{R}{L} \left[\frac{1}{b} \left(e^{-(a-b)t} - e^{-(a+b)t} \right) \right] = E \frac{a}{b} \left[e^{-\alpha t} - e^{-\beta t} \right] \end{aligned}$$

where $\alpha = a - b$, and $\beta = a + b$.

This is a typical exponential wave of $E(e^{-\alpha t} - e^{-\beta t})$ form. If values of R, L and C are inserted, the shape of wave can be found by plotting.

Let $R = 30 \Omega, L = 15 \mu\text{H}$ and $C = 2 \mu\text{F}$. With these values a, b, α and β can be calculated.

$$a = 10^6, b = 0.983 \times 10^6, \alpha = 0.017 \times 10^6, \text{ and } \beta = 1.983.$$

$$\therefore v = 1.107E(e^{-0.017 \times 10^6 t} - e^{-1.983 \times 10^6 t}), \text{ and if } E = 1000 \text{ V and } t \text{ is in } \mu\text{s},$$

$$v = 1017 (e^{-0.017 t} - e^{-1.983 t}).$$

The wave is plotted in Fig. 17.40. With these values R , L and C we obtain a $2.4/40 \mu s$ wave. By adjustment of parameters R , L and C any desired wave shape may be obtained.

17.26. Single Stage Impulse Generators. Impulse generators can be single stage or of multi-stage construction. The single stage generator has a simple circuit of the type shown in Fig. 17.41. This circuit is mainly employed in low voltage applications.

The choice between a single or a multi-stage generator depends upon the output voltage desired and the type of equipment providing d.c. input to the generator.

Where expense is not the main consideration, single stage generators may be used up to a voltage output of 200 kV and even higher. However, small d.c. equipments with ratings of 4 kV and

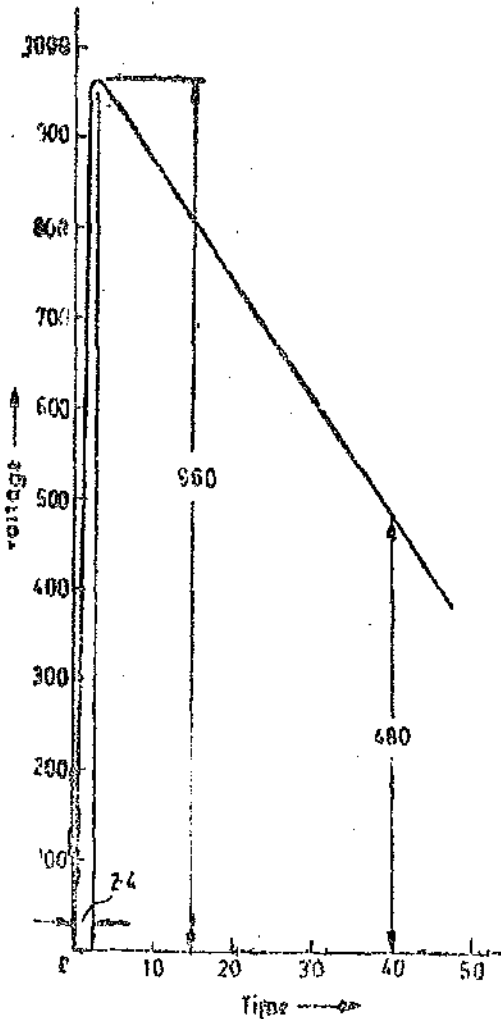

Fig. 17.40. A $2.4/40 \mu s$ surge wave.

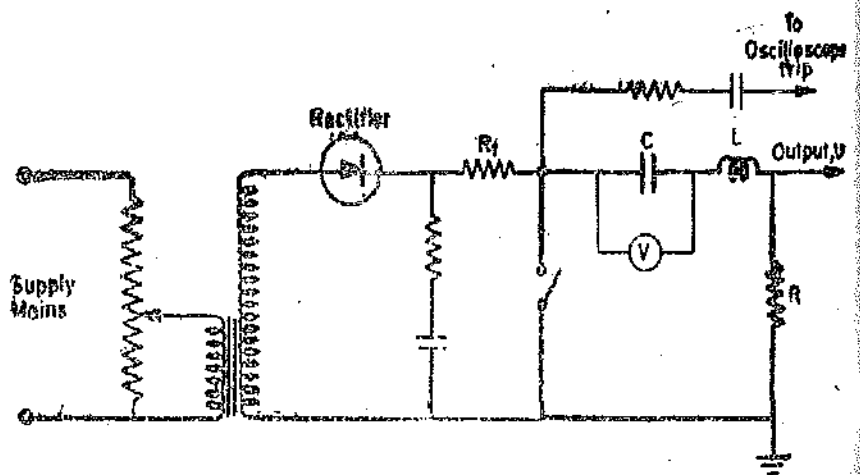

Fig. 17.41. Single stage impulse generator.

10 kV are relatively inexpensive so that single stage generators are readily used at these voltages. For that matter multistage impulse generators with outputs of 100 kV are readily made using (say) 10 stages and a charging voltage of 10 kV.

Fig. 17.41 shows a 200 V single stage impulse generator. The design is the same whether the output voltage is 10 kV or merely 200 V.

The proper single generator circuit is shown by thick lines.

A transformer supplies a rectifier which may be a valve, a metal or a solid state rectifier. For rectification any of the circuits shown in Fig. 17.22 to 17.25 may be used. Resistance R_1 between charging equipment and generator circuit is a limiting resistance which is used to protect the rectifiers against damage when switch is closed.

The voltage across the capacitor is measured by an electrostatic voltmeter.

The recording equipment (C.R.O etc.) may be directly connected if the generator voltage is low. In case the generator voltage is high, connections for recording purposes must be taken through a potential divider arrangement.

17.27. Multi-stage Impulse Generator. The origin of the multi-stage impulse generator circuit in which capacitors are charged in parallel and discharged in series is due to Prof. Marx. A Marx circuit (with modifications by Goodlet) is shown in Fig 17.42.

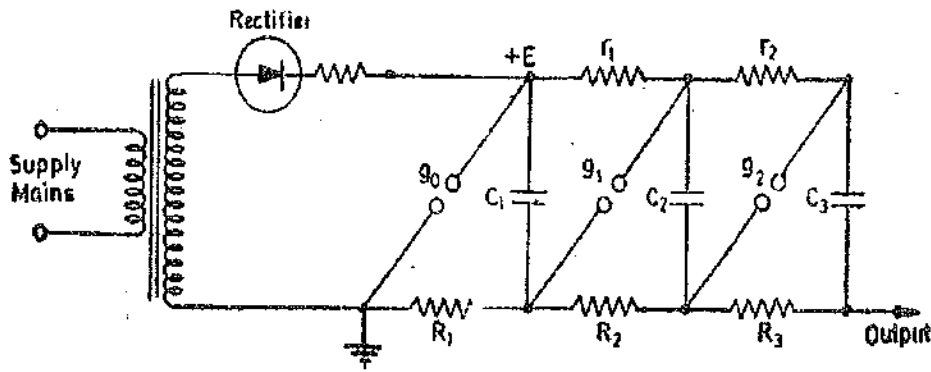

Fig. 17.42. Marx circuit

C_1, C_2, C_3, \dots are capacitors which are connected in parallel with highest resistances R_1, R_2 and r_1, r_2, \dots etc. between them. g_0, g_1, g_2 are the trigger spark gaps.

The capacitors are charged, in parallel, from a high voltage transformer through a rectifying device. At a certain voltage depending upon their setting, the gaps break down and connect the capacitors in series.

The operation of the circuit is explained below :

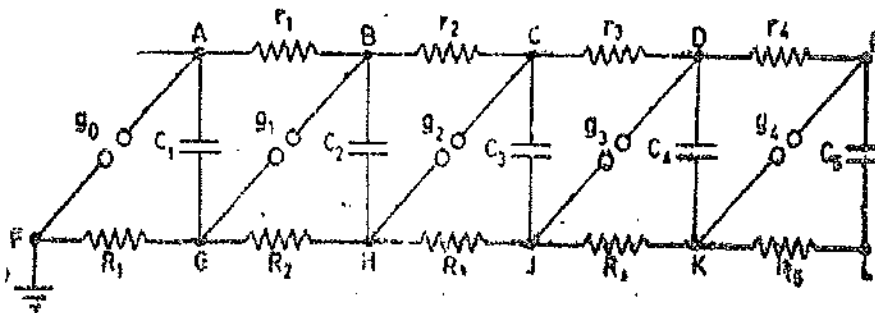

Fig. 17.43. Charging circuit.

The gaps g_0, g_1, g_2 etc. are set to spark one after another. Gap g_0 sparks when the charging voltage has attained a voltage $+E$. All the capacitors will therefore charge in parallel through the resistors shown until they reach a potential of $+E$. Their lower plates are at earth potential because of their connection to ground through resistances.

As soon as a voltage $+E$ is attained, gap g_0 breaks down and there is momentary redistribution of charge potential on capacitor C_1 . Its top plate falls to zero potential and its lower plate potential becomes $-E$ suddenly. Therefore a potential of $2E$ (i.e. $-E$ to $+E$) suddenly appears across gap g_1 and this gap then instantly breaks down. This process is repeated, the potential of lower plates of capacitors of successive stages becoming $-2E, -3E, \dots, -nE$, if there are n stages.

Thus if there are n stages, output voltage is $-nE$ if the charging (input) voltage is $+E$. Figs. 17.43 and 17.44 show the charging and discharging circuits respectively.

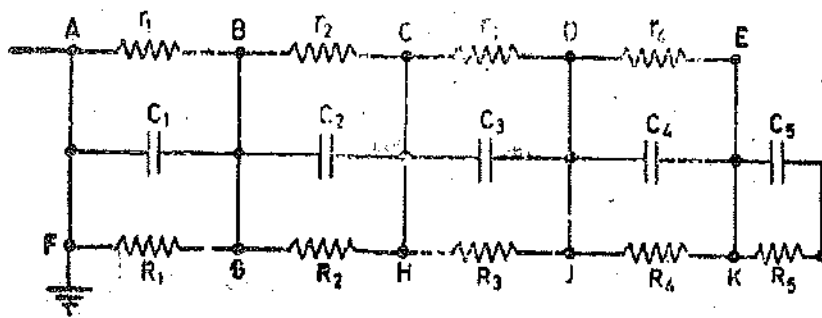

Fig. 17'44. Discharging circuit.

17'28. Impulse Testing of Transformers. The impulse voltages at which transformers are tested are specified in the IS specifications. The impulse test voltage depends upon the rated voltage of the transformers.

The procedure for testing is as follows :

(1) Prior to application of surge, the impulse generator is adjusted to give required "1/50" μ s wave at 75% of required test voltage. The lightning arrester, the voltage measuring equipment and recording devices are connected in circuit. From these calibrations, the generator settings for actual tests are estimated and during tests, no change is made in any part of circuit.

(2) For full wave tests, the generator is set to give full test voltage (specified) and lightning arrester is disconnected to prevent flash over.

(3) For chopped wave tests, the lightning arrester is connected in circuit, and to insure that it chops on the tail of the wave, the impulse generator is set to give 15% in excess of specified test voltage.

Two shots are taken.

(4) Another full wave shot is taken.

During impulse test, observations are made to detect the failure of insulation (it is done by taking oscillograms of applied voltage and impulse current).

In Europe chopped wave tests are not done. Impulse tests are only type tests and are done by specific agreement between manufacturer and purchaser. Although when a transformer is made according to new specifications it has to stand an impulse test.

17'29. Testing of Insulating Materials

Dielectric Strength The dielectric strength of an insulating material may be defined as the minimum voltage gradient at which electrical failure or breakdown occurs under prescribed conditions. Though breakdown of insulation may be caused by leakage current, it is generally caused by voltage stress exceeding the dielectric strength of the material. The dielectric strength is expressed in terms of voltage per unit thickness.

There are wide variations of dielectric strength as it varies with the following factors :

- (i) Structure homogeneity and quality of sample,
- (ii) shape of electrodes,
- (iii) thickness of sample,
- (iv) waveform of test voltage and duration and rate of application of voltage,
- (v) moisture content of specimen, and (iv) heat capacity of electrodes.

Dielectric strength is not proportional to thickness, but is relatively greater for thin sheets. It is also a function of time of application, being greater lesser is the time.

Measurements of capacitance, permittivity, dielectric loss and loss angle of insulating materials is very important. These measurements are usually made at high voltages. All these quantities vary with voltages used for measurements and for some applications values measured at low voltages are of no use at all. Schering bridge, explained in Chapter 16, is normally used for determination of these quantities

17'30. High Voltage Testing of Cables. The tests carried out in the field after the installa-

tion of cables have been explained earlier in this chapter. Here we will describe some acceptance tests which convince the customer about the reliability of the cable when put in service. The dielectric loss and loss angle of a cable rather than its breakdown strength are an index of its reliability in service. Therefore measurements of these quantities is essential.

It has been found that the dielectric loss in a cable is not proportional to square of the voltage as is the case in most dielectrics. Also the loss angle of a cable does not remain constant. The dielectric loss increases in proportion to some power of voltage greater than second and the power factor rises with voltage.

Therefore measurements of loss angles with different voltages is made and a curve plotted between loss angle and voltage. The curve should be flat and if there are variations in the loss angle, the cable will not work satisfactorily. Also the loss angle should not change very much with temperature.

Breakdown tests of the cables with voltages applied for different intervals of time are also done and time versus breakdown voltage curves are plotted.

17.31. High Voltage Tests on Porcelain Insulators. The following tests are applied to porcelain insulators.

1. *Power Frequency Tests.* The frequency used is between 25 to 100 Hz of approximately sine waveform with peak value of voltage not to exceed 1.45 times the rms value.

2. *Flash over Tests.* Porcelain insulators are designed in such a way that their puncture voltage is higher than the flashover voltage. This means that in case of a sudden overvoltage, the air at insulator surface breaks down earlier and thus the insulator is not punctured and is saved from total destruction. Therefore flashover tests are very important in the case of porcelain insulators.

The flashover voltage for an insulator depends upon :

- | | |
|---|-------------------|
| (i) barometric pressure, | (ii) temperature, |
| (iii) shape of the electrostatic field, | (iv) humidity, |
| and (v) nature of contact between electrodes and insulator. | |

The various flashover tests applied are :

(i) *50 percent dry impulse flashover tests with 1/50 μ s impulse voltage.*
 (ii) *Dry flashover and dry one minute test.* In this test the voltage is gradually raised to a specified value in approximately 10 seconds and is maintained for one minute. The voltage is then gradually raised until a flashover occurs.

(iii) *Wet flashover and one minute rain test.* During this test the insulator is sprayed constantly with water and the same procedure as for dry flashover and dry one minute test is followed.

3. *Sample Tests.* These include mechanical tests, temperature cycle tests, porosity tests, puncture tests etc.

4. *Routine Tests.* These tests are applied to all the insulators. The insulators are initially subjected to a low voltage which is rapidly increased till a flashover occurs every few seconds. The voltage is maintained at this value for a minimum of 5 minutes or if failure occurs, for five minutes after the last punctured piece has been removed. The voltage is gradually reduced to $\frac{1}{3}$ rd of its value before supply is switched off.

In addition to above tests, porcelain insulators used on power networks are tested for damped high frequency oscillations.

The porcelain insulators used for communication purposes are tested with high frequency undamped oscillations.

17.32. Testing of Electric Strength of Insulating Oils. An abstract of IS specifications 6792-1972 "Method for determination of Electric strength of insulating oils" is given below :

Electrodes. The electrodes may be made of copper, brass, bronze or stainless steel. The polished electrodes are either spherical (12.5 to 13.0 mm diameter) as shown in Fig. 17.45 or spherical surfaced of the shape and dimensions as shown in Fig. 17.46. The electrodes are mounted 2.5 mm apart with an accuracy of ± 0.1 mm. The axis of the electrodes is immersed to a depth of approximately 40 mm. The electrodes are replaced as soon as pitting caused by discharges is observed.

Test Method. The oil is poured in the dry and clean cell and is stirred so that the impurities are evenly distributed and there are no visible air bubbles. The temperature of oil is the same as that of ambient air preferably 27°C, but a temperature range of 15°C to 35°C is acceptable.

An increasing a.c. voltage of frequency 40-60 Hz is applied to the electrodes. The rate of increase of voltage is uniform and is approximately equal to 2 kV/s starting from zero to the value producing breakdown. The breakdown voltage is the voltage reached during the test at the time first spark occurs between electrodes. The test is carried out six times on the same cell filling. The electric strength is the arithmetic mean of the six results obtained.

Electrical Apparatus. The characteristics of the electrical apparatus comply with the following requirements.

Transformer. The test voltage is obtained by using a step up transformer supplied from a.c. The low voltage side has a frequency of 40 to 62 Hz. The primary voltage is gradually increased, either manually or by an automatic control device. The voltage applied to the electrodes has approximately a sinusoidal waveform such that peak factor is within 1.34 to 1.48 i.e. $\sqrt{2} \pm 5\%$. The transformer and associated equipment are designed to produce a minimum short circuit current of 20 mA for a voltage higher than 15 kV. In order to avoid damage to electrodes the short circuit current is limited to 1 A, if necessary, by addition of external impedance.

Protective Gear. The test is carried out so as to prevent high frequency oscillations as far as possible. In order to protect the equipment and to avoid excessive decomposition of the oil at the instant of breakdown, a resistance, limiting the current is inserted in the test cell circuit. The primary circuit of the high voltage transformer is fitted with a circuit breaker operated by the current flowing, following the breakdown of the sample, and with a delay not more than 0.02 s. The circuit breaker is fitted with a no volt coil to protect equipment.

Voltage Regulation. Voltage regulation may be insured by one of the following methods:

(i) Variable ratio auto-transformer, (ii) resistance type voltage regulator, (iii) generator field excitation, and (iv) induction regulator.

Preference is given to an automatic system for increasing voltage, since it is difficult to obtain manually a reasonably uniform rate of voltage rise as a function of time.

Measurement of Test Voltage. For the purpose of this standard, the magnitude of test voltage is defined as its peak value divided by $\sqrt{2}$. The peak value of the test voltage is measured by a peak voltmeter. The test voltage is determined by a voltmeter suitably connected to the input or output side of the testing transformer, or to a voltmeter suitably connected to input or output side of the testing transformer or to a voltmeter winding provided thereon and calibrated against a sphere gap in place of the test cell.

The voltage should be measured to an accuracy better than $\pm 4\%$.

Results. The test report should include

(i) Reference to the standard, (ii) breakdown voltages obtained during each test, (iii) average of breakdown voltages, (iv) types of electrodes, (v) frequency of test voltage, and (vi) oil temperature.

The extract of IS specification 335-1972 "Specification for new insulating oils for transformers and switch gear" is given below:

The electric strength (breakdown voltage) of new insulated oil for transformers and switchgear should have a minimum value of 3 kV/mm (rms). If this value is not attained, the oil has to be treated. The breakdown voltage after treatment should be at least 5 kV/mm (rms).

The maximum dielectric dissipation factor at 90°C is 0.005. The resistivity is 13×10^{10} Ω m (minimum) at 90°C and 509×10^{10} Ω m (minimum) at 27°C.

Permittivity should be approximately 2.2 (-0.001) at 60°C.

Magnetic Measurements

18.1. Introduction. Electrical and magnetic phenomena are closely associated with each other. The operating characteristics of electrical machines, apparatus and instruments are greatly influenced by the properties of ferro-magnetic materials used for their construction. Therefore, magnetic measurements and a thorough knowledge of characteristics of magnetic materials is of utmost importance in designing and manufacturing electrical equipment.

The principal requirements in magnetic measurements are :

- (i) The measurement of magnetic field strength in air.
- (ii) The determination of B-H curve and hysteresis loop for soft ferro-magnetic materials.
- (iii) The determination of eddy current and hysteresis losses of soft ferro-magnetic materials subjected to alternating magnetic fields.
- (iv) The testing of permanent magnets.

Magnetic measurements have some inherent inaccuracies due to which the measured values depart considerably from the true values. The inaccuracies are due to the following reasons :

- (i) the conditions in the magnetic specimen under test are different from those assumed in calculations ;
- (ii) the magnetic materials are not homogeneous ;
- (iii) there is no uniformity between different batches of test specimens even if such batches are of the same composition.

18.2. Types of Tests. Many methods of testing magnetic materials have been devised wherein attempts have been made to eliminate the inaccuracies. However, attention will be confined to a few basic methods of ferro-magnetic materials. They are :

(i) *Ballistic Tests* : These tests are generally employed for the determination of B-H curves and hysteresis loops of ferro-magnetic materials. Direct current is used to provide an adjustable mmf to the magnetic circuit, and a ballistic galvanometer or flux meter is employed for the measurement of flux density.

The ballistic methods do not directly measure the value of flux density in a magnetic material corresponding to a particular value of magnetizing force but measure instead the changes in flux brought about by changes in magnetising force. These changes in flux density are either measured by a flux meter or a ballistic galvanometer.

(ii) *A.C. Testing*. These tests may be carried at power, audio or radio frequencies. They give information about eddy current and hysteresis losses.

(iii) *Steady State Tests* : These are performed to obtain the steady value of flux density existing in the air gap of a magnetic circuit.

BALLISTIC TESTS

18.3. Measurement of Flux Density. The measurement of flux density inside a specimen can be done by winding a search coil over the specimen. This search coil is known as a "B coil". This search coil is then connected to a ballistic galvanometer or a flux meter. Let us consider that

we have to measure the flux density in a ring specimen shown in Fig. 18'1. The ring specimen is wound with a magnetizing winding which carries a current I . A search coil of convenient number of turns is wound on the specimen and connected through a resistance and calibrating coil, to a ballistic galvanometer as shown.

The current through the magnetizing coil is reversed and therefore the flux linkages of the search coil change inducing an emf in it. This emf sends a current through the ballistic galvanometer causing it to deflect.

Let Φ = flux linking the search coil,
 R = resistance of the ballistic galvanometer circuit,
 N = number of turns in the search coil,
 and t = time taken to reverse the flux.

\therefore Average emf induced in the search coil

$$e = N \frac{d\Phi}{dt} = \frac{2N\Phi}{t}$$

Average current through the ballistic galvanometer is $i = \frac{2N\Phi}{Rt}$.

Charge passing $Q = it = \frac{2N\Phi}{R}$.

Let θ_1 be the throw of the galvanometer and K_g be the constant of the galvanometer expressed in coulomb per unit deflection.

Charge indicated by ballistic galvanometer = $K_g \theta_1$.

$\therefore \frac{2N\Phi}{R} = K_g \theta_1$ or flux $\Phi = \frac{RK_g \theta_1}{2N}$.

In a uniform field and with search coil turns at right angles to the flux density vector, we have, flux density,

$$B = \frac{\text{flux}}{\text{area}} = \frac{\Phi}{A_s} = \frac{RK_g \theta_1}{2NA_s} \quad \dots(18'1)$$

where A_s = cross-sectional area of specimen.

Thus the flux density may be measured by a ballistic galvanometer by observing its throw.

Correction for air flux. For the above calculations, we have assumed that the flux is uniform throughout the specimen, and that the effective area of cross-section of the search coil is equal to the cross-sectional area of the specimen. However, the search coil is usually of larger area than the specimen and thus the flux linking with the search coil is the sum of the flux existing in the specimen and the flux which is present in the air space between the specimen and the search coil.

\therefore Observed value of flux

= true value of flux in the specimen + flux in the air space between specimen and search coil.

or $B' A_s = B A_s + \mu_0 H (A_c - A_s)$.

Hence true value of flux density $B = B' - \mu_0 H \left(\frac{A_c}{A_s} - 1 \right)$... (18'2)

where B' = observed (or apparent) value of flux density, B = true value of flux density in specimen, A_s = area of cross-section of specimen, and A_c = area of cross-section of coil.

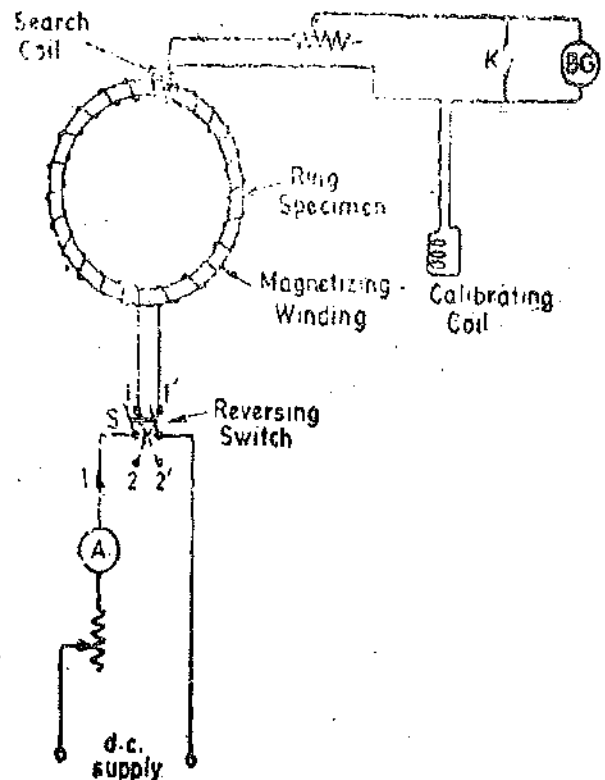

Fig. 18'1. Measurement of flux density in ring specimens.

18'4. **Measurement of Value of Magnetising Force (H).** The magnetising force of a constant magnetic field may be measured by a ballistic galvanometer and a search coil. The value of H inside a specimen can either be inferred from calculations involving data of magnetising coil and the specimen or from measurements made outside the specimen. It cannot be measured directly. If the magnetising force is to be determined in the air gap, the search coil is placed in the air gap itself. While testing ferro-magnetic materials, the magnetising force, within the specimen may be determined by measuring the magnetising force on its surface, since the tangential components of the field are of equal in magnitude for both sides of the interface. The search coil, as positioned in Fig. 18'2, measures the value of flux density, B_0 , in air. This search coil is called an "H coil". While for the flux densities encountered in iron testing, there is usually no trouble in getting a good sensitivity by using B coil of sufficient turns but there is some difficulty in securing adequate sensitivity in the 'H' coil placed at the surface. In the first instance, its cross-sectional area is much smaller than the coil surrounding the specimen (*i.e.* B coil) and then H is not constant across the section. Secondly, the permeability of iron is very large as compared to air—may be some thousand times and therefore flux density B_0 , in search coil, is very small compared to that in specimen. The value of flux density B_0 in H coil is measured in a similar manner as described above for determination of B in the specimen.

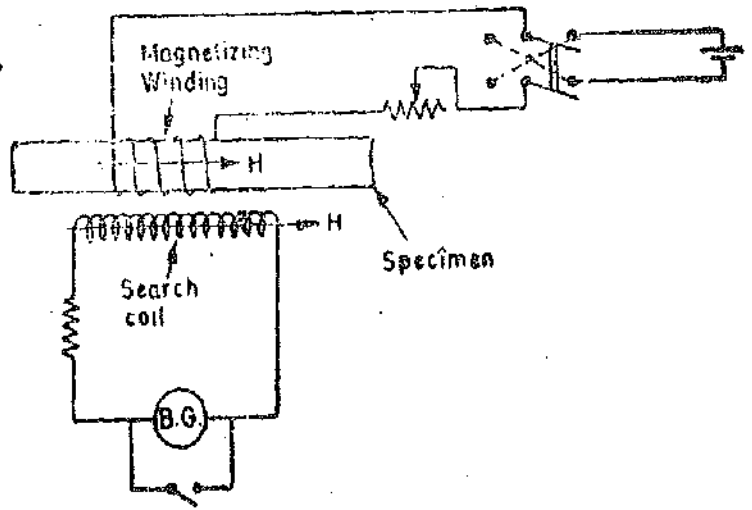

Fig. 18'2. Determination of magnetising force H .

$$\text{Magnetising force } H = \frac{B_0}{\mu_0} \quad \dots(18'3)$$

18'5. **Magnetic Potentiometer.** This is a device for measurement of magnetic potential difference between two points. It can be shown that the line integral of magnetizing force H produced by a coil of N concentrated turns carrying a current I is :

$$\int H dl = NI \quad \dots(18'4)$$

around any closed path linking the coil. This is the circuital law of the magnetic field and forms the basis of magnetic potentiometer. A magnetic potentiometer may be used to determine the mmf around a closed path, or the magnetic potential difference between two points in a magnetic circuit.

A magnetic potentiometer consists of a one metre long flat and uniform coil made of two or four layers of thin wire wound unidirectionally on a strip of flexible non-magnetic material. The coil ends are brought out at the middle of the strip as shown in Fig. 18'3 and connected to a ballistic galvanometer. The magnetic potential difference between points A and B of the field is measured by placing the ends of the strip at these points and observing the throw of the ballistic galvanometer when the flux through the specimen is changed. Supposing the flux is changed by reversing the field.

- Let A = area of the strip,
 n = number of turns per unit length of the strip,
 H_1 = tangential component of the magnetising force, and
 R = resistance of the ballistic galvanometer circuit.

\therefore Flux linkages of a small infinitesimal portion of strip of length dl are :

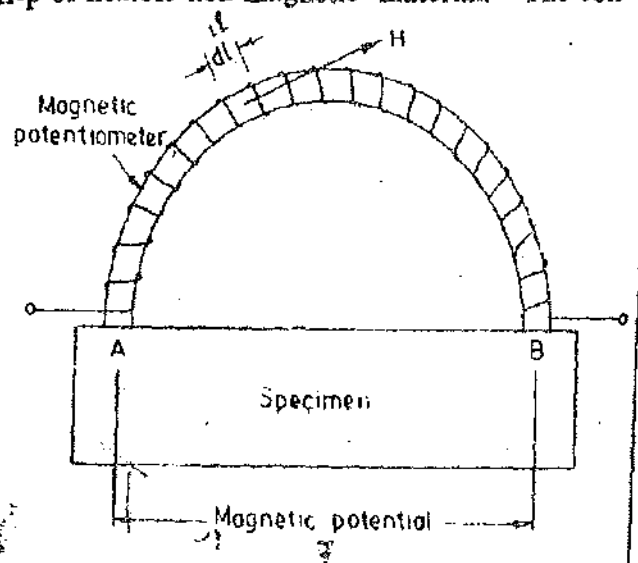

Fig. 18'3. Magnetic potentiometer.

$$= \text{flux} \times \text{turns} = (\mu_0 H_1 A) n \, dl = \mu_0 H_1 A n \, dl.$$

$$\text{Total flux linkages of strip} = \int \mu_0 H_1 A n \, dl = \mu_0 A n \int H_1 \, dl.$$

When the current in the magnetising winding is reversed, change in flux linkages

$$= 2\mu_0 A n \int H \, dl.$$

But $\int H_1 \, dl = \mathcal{F}$ = magnetic potential difference between *A* and *B*.

$$\therefore \text{Change in flux linkages} = 2\mu_0 A n \mathcal{F}$$

$$\text{Charge } Q = it = \frac{2\mu_0 A n \mathcal{F}}{Rt} \quad t = \frac{2\mu_0 A n}{R} \mathcal{F} \quad \dots(i)$$

$$\text{Charge indicated by galvanometer } Q = K_g \theta_1 \quad \dots(ii)$$

From (i) and (ii), we get

$$\text{Magnetic potential difference } \mathcal{F} = \frac{R K_g \theta_1}{2\mu_0 A n} \quad \dots(18.5)$$

The value of constant of galvanometer, K_g , can be found with the help of a calibrating circuit.

The above analysis is only valid if the portion *AB* of the specimen does not carry any part of magnetising winding. As under such condition (i.e., no magnetising winding on portion *AB*), it is impossible to obtain uniform values of *H* over the entire length *AB* and hence this method is rarely used for direct measurement of *H*.

The magnetic potentiometer measures the magnetic potential drop along any part of a magnetic circuit and hence distribution of mmf round the circuit. It can also be used to determine magnetic potential drop across a joint in the magnetic circuit or between two points between which magnetic leakage is suspected.

18.6. Testing of Ring Specimens. Under properly controlled conditions, the ballistic methods which use specimen in the form of a ring give the highest accuracy. The principal advantage of ring specimens is that the end effects are absent in them and they are free from errors resulting from magnetic leakage.

The magnetizing winding should be wound uniformly on the ring otherwise the mmf distribution will be non-uniform which will result in magnetic leakage with consequent errors in the measurements. The magnetising force is usually calculated in terms of mean diameter of the ring and the mmf in the magnetising winding. However, since the inner circumference of the ring is smaller than the outer, the magnetising force and the flux density are not uniform over the cross-section of the ring. The error involved depends upon the ratio of mean diameter and the radial width of the ring. If the ratio of mean diameter to the radial width is more than 8, both magnetising force and the flux density are sufficiently uniform over the cross-section of the specimen and consequently the error involved is not significant.

The ring specimens may take one of the following forms :

(i) *Laminated.* This is the usual form for isotropic sheet materials. The ring is assembled with the directions of rolling of individual laminations distributed radially, in order that the test should yield results corresponding to mean properties of the material.

(ii) *Clock-spring.* A long strip of material may be wound in the form of a spiral to form a ring. The form is suitable for testing anisotropic materials i.e., grain oriented cold rolled steel.

(iii) *Solids.* Solid rings prepared by either casting or forging may be used. Ring specimens are also used for testing powder or dust core materials.

The use of ring specimens in magnetic testing is limited owing to the labour involved in preparing them, since the magnetising winding has to be put with hand for each individual specimen. Also the value of magnetising force is limited by heating. Ring specimens are mainly used in the testing of small quantities of materials of very high permeability.

18.7. Determination of B-H Curve. There are two methods available for the determination of B-H curve of a specimen.

1. **Method of Reversal.** A ring shaped specimen whose dimensions are known is used for the purpose. A layer of thin tape is put on the ring and a search coil insulated by paraffined wax is wound over the tape. Another layer of tape is put over the search coil and the magnetising winding is uniformly wound over this tape. The test circuit is shown in Fig. 18'1.

After demagnetizing, the test is started by setting the magnetising current to its lowest test value. With galvanometer key K closed, the iron specimen is then brought into a 'reproducible cyclic magnetic state' by throwing the reversing switch S backward and forward about twenty times. Key K is now opened and the value of flux corresponding to this value of H is measured by reversing the switch S and noting the throw of galvanometer. The value of flux density corresponding to this H can be calculated by dividing the flux by the area of the specimen.

The above procedure is repeated for various values of H upto the maximum testing point. The B - H curve may be plotted from the measured values of B corresponding to the various values of H .

2. **Step by step method.** The circuit for this test is shown in Fig. 18'4. The magnetising winding is supplied through a potential divider having a large number of tappings. The tappings are arranged so that the magnetising force H may be increased, in a number of suitable steps, upto the desired maximum value. The specimen before being tested is demagnetised.

The tapping switch S_2 is set on tapping 1 and the switch S_1 is closed. The throw of the galvanometer corresponding to this increase in flux density in the specimen, from zero to some value

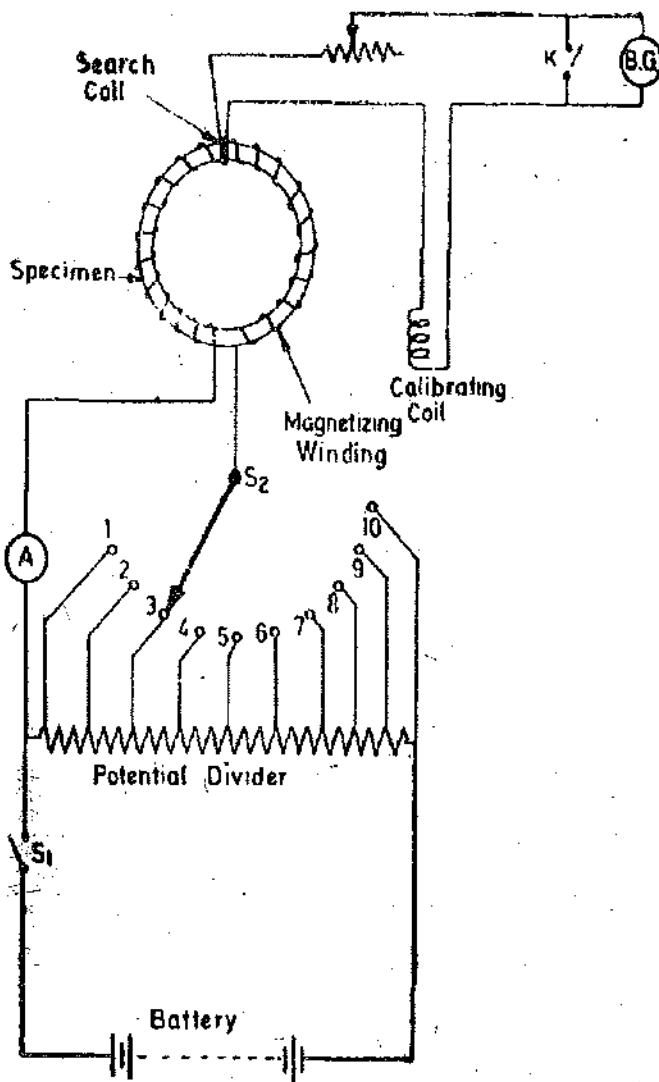

Fig. 18'4. Determination of B - H curve by step by step method.

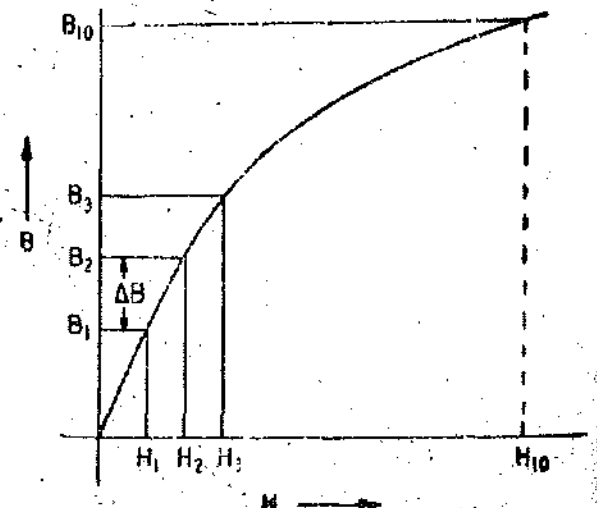

Fig. 18'5. B - H curve.

B_1 is observed. The value of B_1 can be calculated from the throw of the galvanometer. The value of corresponding magnetising force H_1 may be calculated from the value of current flowing in the magnetising winding at tapping 1. The magnetising force is then increased to H_2 by switching S_2 suddenly to tapping 2, and the corresponding increase in flux density ΔB is determined from the throw of the galvanometer. Then flux density B_2 corresponding to magnetising force H_2 is given by $B_1 + \Delta B$. This process is repeated for other values of H upto the maximum point, and the complete $B-H$ curve is thus obtained as shown in Fig. 18.5.

18.8. Determination of Hysteresis Loop

1. Step by step method. The determination of hysteresis loop by this method is done by simply continuing the procedure just described for the determination of $B-H$ curve. After reaching the point of maximum H i.e., when switch S_2 is at tapping 10, the magnetising current is next reduced, in steps to zero by moving switch S_2 down through the tapping points 9, 8, 7 3, 2, 1. After reduction of magnetising force to zero, negative values of H are obtained by reversing the supply to potential divider and then moving the switch S_2 up again in order 1, 2, 3, 7, 8, 9, 10.

2. Method of reversals. This test is done by means of a number of steps, but the change in flux density measured at each step is the change from the maximum value $+B_m$ down to some lower value. But before the next step is commenced the iron specimen is passed through the remainder of the cycle of magnetisation back to the flux density $+B_m$. Thus the cyclic state of magnetisation is preserved.

The connections for the method of reversals are shown in Fig. 18.6. R, R_2 and R_1 are resistances in the magnetising winding and galvanometer circuits. R_3 is a variable shunting resistance

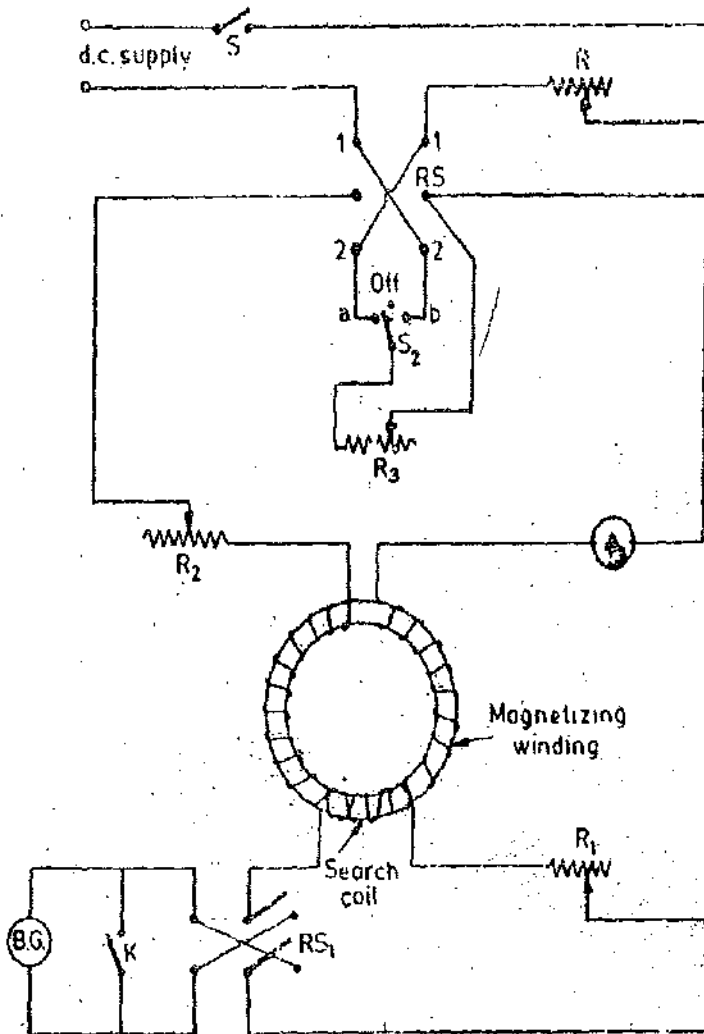

Fig. 18.6. Determination of hysteresis loop step by step method.

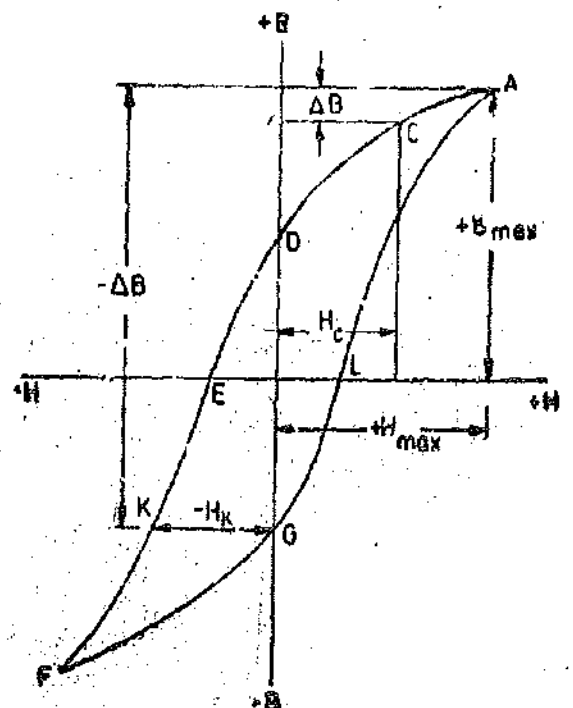

Fig. 18.7. Hysteresis loop.

which is connected across the magnetising winding by moving over the switch S_2 . Thus the current in this winding can be reduced from its maximum value down to any desired value by adjusting the value of R_3 . The procedure for the test is :

The value of magnetising force H_m required to produce flux density B_m to be used during the test is obtained from the previously determined BH curve of the specimen. The resistances R_2 and R are then adjusted so that the magnetising current is such that this value of H (i.e., H_m) is obtained when switch S_2 is in off position. The resistance R_1 is adjusted so that a convenient deflection of galvanometer is obtained when the maximum value of magnetising force is reversed. Resistance R_3 is adjusted to such a value that a suitable reduction of the current in the magnetising winding is obtained when the resistance is brought into the circuit.

Switch RS is placed on contacts 1, 1' and key K is opened. Since the maximum value of current is flowing in the magnetising winding, the magnetisation of the specimen corresponds to point A on the hysteresis loop shown in Fig. 18'7.

Now switch S_2 is quickly thrown over from off position to contact b , thus shunting the magnetising winding with resistance R_3 . The magnetising force is thus reduced to H_c (say). The corresponding reduction in the value of flux density ΔB can be known from the galvanometer deflection and thus point C is located on the hysteresis loop.

The key K is now closed, and switch RS reversed on to contacts 2, 2'. Switch S_2 is then opened and switch RS moved back again to contacts 1, 1'. This procedure passes the specimen through the cycle of magnetisation and back to the point A . The specimen is now ready for the next step in the test. The part AD of the loop is obtained by continuation of this procedure.

To obtain part DEF of the loop, switch RS is placed on contacts 1, 1' with key K closed and S_2 in off position. Now place switch S_2 on contact a , open the key K and rapidly reverse RS on to contacts 2, 2'. This causes the magnetizing force to change from $+H_m$ to $-H_c$ (say). From the throw of the galvanometer change in flux density $\Delta B'$ can be calculated. Thus point E on the hysteresis loop can be located. The magnetisation of the specimen is brought back to point A by reversing switch RS on to contacts, 1, 1' with key K closed.

By continuing this procedure, other points on part DEF of the hysteresis loop are obtained. Thus part $AD EF$ of the loop can be traced. The part $F G A$ of the loop may be obtained by drawing in the reverse of part $A D E F$ as the two halves are identical.

18'9. Testing of Bar Specimens. It is obviously clear that it is difficult to prepare ring specimens while on the other hand bar specimens are much easier to construct. However, if the tests and methods described above are applied to bar specimens, some difficulties and inaccuracies arise in testing. This is because when we use bar specimens, the return circuit for the flux is through air whose reluctance is very high. Also, when the bar is magnetised, poles are produced at its ends, and these poles produce, inside the rod a magnetising force which acts from the north pole to the south which is in opposition to the applied magnetising force. This is called self-demagnetisation (or end effects). Thus the value H of the magnetising force which is effective in producing the flux in the specimen is less than the applied magnetising force H' as calculated from the mmf of the magnetising winding.

The true magnetising force, $H = H' - H_d$

where H' = applied magnetising force

$$= \frac{NI}{l} \text{ for a long solenoid}$$

$$= \frac{NI}{\sqrt{l^2 + d^2}} \text{ for a short solenoid for length } l \text{ and diameter } d.$$

and H_d = magnetising force due to self-demagnetisation.

In order to obtain accuracy in measurements with bar specimens, we must apply corrections for the demagnetising force or reduce the effect to negligible proportions. However, the self-demagnetising force H_d is somewhat an uncertain quantity.

Since the effect of demagnetising force is small when the ratio of length to diameter of bar is large, the dimensions of the specimen should be so chosen that the effect of demagnetisation is negligible. It has been found that if the ratio of length to diameter of bar specimens is 25 or more, the demagnetising has negligible effect on the value of magnetising force.

18'10. Permeameters. Most methods employed in magnetic testing are designed to avoid the errors and difficulties of the simpler ring or bar tests. These methods tend to combine the good qualities of both bar and ring specimens.

In general, testing is done with the help of permeameters, which make use of straight bar specimens and also provide a return path of low reluctance and thus reduce or in some cases entirely remove the effects of self demagnetisation (end effects). All permeameters use return paths of large cross-sectional area in order to make the reluctance of paths negligible as compared with that of the bar specimens. However, they differ in such details as the degree of compensation of leakage flux or the method by which the magnetisation force is determined or in the range of magnetising force, for which they can be used.

Most of the permeameters incorporate modifications of the bar and yoke arrangement first described by Hopkinson.

18'11. Hopkinson Permeameter (Bar and Yoke Method). A test coil is wound upon the central part of a bar specimen. The bar is clamped between two halves of a massive iron yoke (i.e., a yoke having a large cross-sectional area) whose reluctance is low compared to that of the bar specimen. This yoke provides a return path for the flux. The bar specimen is wound with a magnetising winding as shown in Fig. 18'8.

Let N = number of turns on the magnetising winding,

I = current in the magnetising winding.

l = length of the bar specimen between two halves of the yoke,

A_s = area of cross-section of the specimen,

μ_s = permeability of the specimen when the magnetising current is I ,

R_y = reluctance of the yoke,

R_j = reluctance of the joints between the bar specimen and the yoke,

and Φ = flux in the magnetic circuit.

Then,

$$\text{Reluctance of specimen } R_s = \frac{l}{\mu_s A_s}$$

$$\therefore \text{Flux } \Phi = \frac{\text{mmf}}{\text{reluctance of magnetic circuit}}$$

$$= \frac{NI}{R_y + R_j + l/(\mu_s A_s)}$$

$$\text{Flux density in the specimen } B = \frac{\Phi}{A_s} = \frac{NI}{A_s(R_y + R_j + l/(\mu_s A_s))}$$

$$\text{Magnetising force } H = \frac{B}{\mu_s} = \frac{NI}{\mu_s A_s(R_y + R_j + l/(\mu_s A_s))}$$

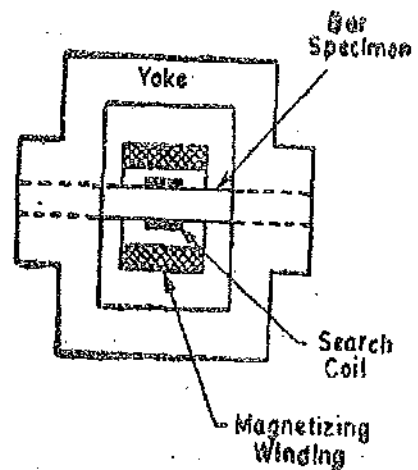

Fig. 18'8. Bar and yoke method.

$$\text{Let } m = \frac{\text{reluctance of (yoke+joints)}}{\text{reluctance of specimen}} = \frac{R_y + R_j}{l\mu_s A_s} = \frac{\mu_s A_s}{l} (R_y + R_j) \quad \dots(18'6)$$

$$\therefore H = \frac{NI}{l(1+m)} \quad \dots(18'7)$$

The value of m is made small by keeping the reluctance of yoke and that joints to a small value. This can be done by carefully fitting the specimen into the yoke (so that air space between bar and yoke is negligible) and making the yoke of a large cross-section.

If m is made small as described above, we have :

$$H = \frac{NI}{l} (1-m) \quad \dots(18'8)$$

Thus the actual value of magnetising force differs from the calculated value of magnetising force (NI/l) by the amount $=mNI/l$.

The value of flux density is measured by a ballistic galvanometer in the usual way.

18.12. Ewing Double Bar Permeameter. This permeameter consists of two exactly similar bars made up of magnetic material under test. There are two pairs of magnetising coils. One pair of coils is exactly half the length of the other pair. Thus there are in all four magnetizing coils, two having full length and the two having half length. The number of turns per unit axial length is same for all the coils. Each bar is wound with two coils, one of full and the other of half length.

The bars fit tightly into holes of two yokes. The yokes are made of annealed soft iron. The position of these yokes on the bars can be adjusted. The arrangement of bars and yokes is shown in Fig. 18'9.

The purpose of this arrangement is the elimination of the reluctance of yoke and joints. Two tests are made, one with length of specimen $=l$ and the other with length $=l/2$. It is assumed that for both positions, the reluctance of yokes and the joints is the same for a given flux density.

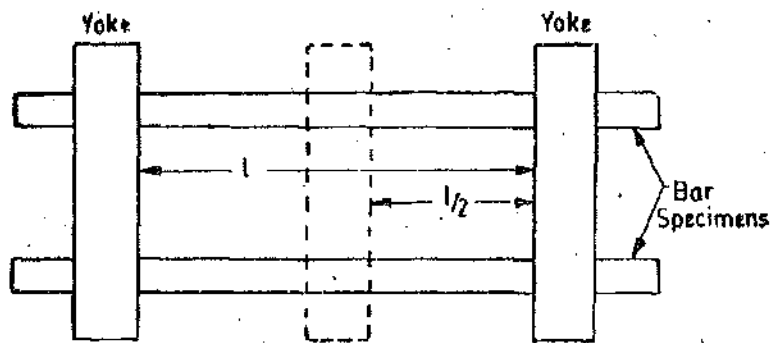

Fig. 18'9. Ewing permeameter.

Let,

n = number of turns per unit length of magnetising coils,

I_1 = current in the coils when the specimen length is l ,

I_2 = current in the coils when the specimen length is $l/2$,

H_1 = apparent magnetising force when length is l ,

H_2 = apparent magnetising force when length is $l/2$,

\mathcal{F} = mmf required for the yokes and the joints in each case,

and B = flux density in the specimen (it is the same in both the cases).

$$\text{Then } H_1 = \frac{nI_1}{l} = nI_1 \quad \text{and} \quad H_2 = \frac{nI_2}{l/2} = nI_2.$$

If H is the true magnetising force in the iron for a flux density B , then we have

$$H_1 l = Hl + \mathcal{F} \quad \dots(i)$$

$$\text{and } H_2 l/2 = Hl/2 + \mathcal{F}. \quad \dots(ii)$$

(This is because, total applied mmf = mmf required for iron + mmf required for yoke and joints).

From (i) and (ii), true magnetizing force $H=2H_1-H_2$ (18.9)

The flux density B corresponding to this value of H is measured with the help of a ballistic galvanometer.

The disadvantages of this method are

(i) the reluctance of yokes and joints is not exactly same for the two positions of the yoke,

(ii) the test requires two exactly similar bars,

and (iii) the test is quite lengthy in operation.

The methods which have been discussed above are very easy to use and this is their greatest advantage. However, these methods are no longer used for magnetic testing. It is not difficult to make the reluctance of yoke negligible, but the reluctance of joints is not small and more over is indefinite. Suppose for example a specimen is 25 cm long and is being tested at a permeability 5000 times

that of air. Then an air gap of $\frac{25}{5000} = 5 \times 10^{-3} \text{ cm} = 0.5 \text{ mm}$ at the joints will have as much reluctance

as the whole the specimen. Thus under these conditions (and the conditions can be worse when the relative permeability is too high) to be sure that joint reluctance is negligible and definite is impossible. Ewings double bar method does not get over this difficulty, as it assumes the two joints to have similar reluctances. Thus these methods are obsolete.

18.13. Illiovi Permeameter. The construction of this permeameter is shown in Fig. 18.10.

It consists of a bar specimen clamped against a heavy section yoke. The bar is wound with a magnetising winding and a search coil. The search coil is connected across a ballistic galvanometer BG_1 . A magnetic potentiometer is connected to a section AB of the bar specimen. The yoke is provided with a compensating winding. This winding is connected in parallel with the magnetising winding across a reversing switch. When the magnetic potentiometer indicates no magnetic potential drop, the mmf for part AB is provided by the magnetising winding while for the remaining part of the specimen, the yoke and the joints, is provided by the compensating winding. This condition is attained by adjusting the current in the main winding to the required test value and then adjusting the current in the compensating winding so that the ballistic galvanometer BG_2 shows no throw when the currents are reversed. Under this condition there is no flux through the magnetic potentiometer* and therefore no difference of magnetic potential exists between points A and B . Thus the magnetising force for length AB is given by $H=NI/l$

where N = number of turns in the magnetising winding,

I = current in the magnetising winding,

and l = length AB .

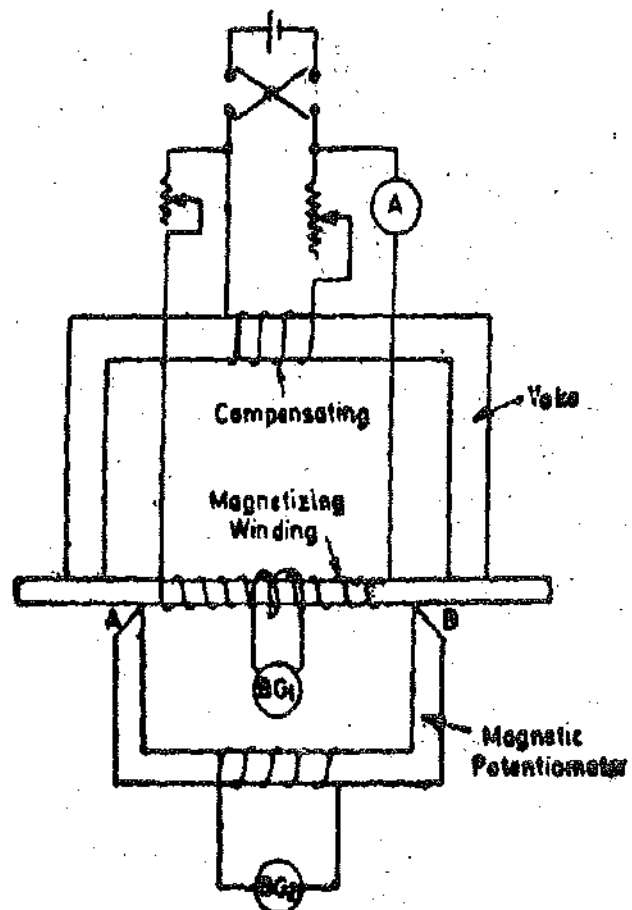

Fig. 18.10. Illiovi permeameter.

*It should be noted that in general magnetic potentiometer cores should be of non-magnetic materials but in the Illiovi permeameters ferric-magnetic cores are allowable since it is used as a null detector and not for actual measurement.

The flux density in the specimen is found by noting the throw of ballistic galvanometer BG_1 when the currents in the magnetizing and the compensating windings are reversed simultaneously.

This permeameter has the following disadvantages.

- (i) Results obtained for this permeameter are not satisfactory because there is lack of symmetry of arrangement.
- (ii) This permeameter does not incorporate a direct test of uniformity of magnetisation along the specimen.
- (iii) Operation is complicated on account of readjustment of compensating winding for each reading.
- (iv) Errors may also be caused on account of some leakage flux between yoke and specimen and the magnetic potentiometer may be affected by leakage flux.

18'14. Burrows Permeameter. This permeameter uses a number of compensating coils which apply compensating mmf at different parts of the magnetic circuit. The mmfs of these coils are so arranged that the entire magnetic circuit is brought to a uniform distribution of magnetic potential. Under this condition there is no magnetic leakage between one part of circuit to another, and magnetising force can be calculated at any point in terms of the magnetising mmf per unit length at that point.

Fig 18'11 shows the arrangement of the magnetic circuit and the coils. S_1 is the bar specimen to be tested. S_2 is an auxiliary bar. These bars are uniform and similar in dimensions and have similar magnetic properties. The bars are surrounded by magnetising windings M_1 and M_2 which are uniformly wound over the bars. A_1, A_2, A_3 and A_4 are compensating windings for the elimination of leakage effects at the joints between the two bars and the yoke. $a, b,$ and c are search coils and have equal number of turns. Coil a surrounds the middle of the test specimen S_1 ; coil b is divided into two equal parts which are located near the ends of bar S_1 ; coil c is located at the middle of the auxiliary bar S_2 .

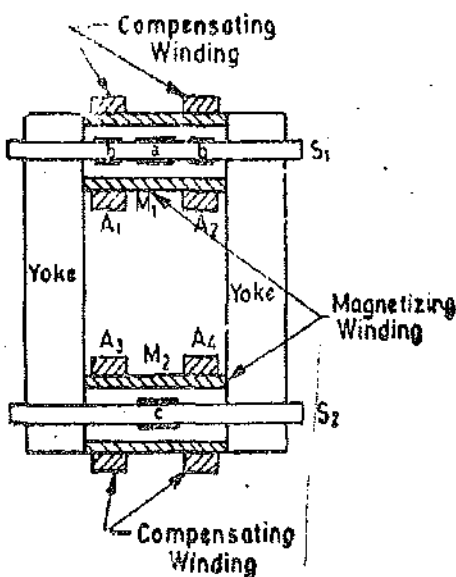

Fig. 18'11. Burrows permeameter.

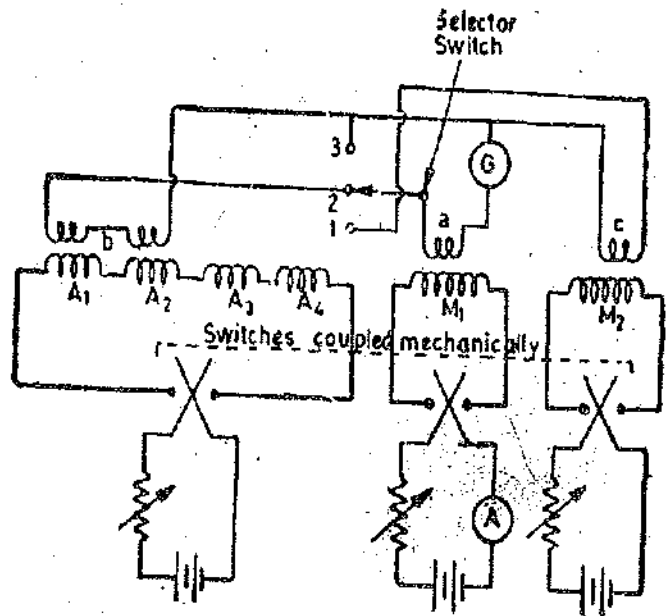

Fig. 18'12. Electrical circuit of Burrow's permeameter.

The electrical connections of the coils are shown in Fig. 18'12. The compensating windings A_1, A_2, A_3 and A_4 are connected in series and are supplied from a separate battery and coil M_2 from another.

In carrying out this test it is necessary to ensure that, for a given value of current M_1 , the flux linking with all the search coils a, b, c is the same. This is done by adjusting the current through compensating windings and the magnetising winding M_2 . If the flux linking with the search coils a, b and c is the same, there can be no appreciable leakage flux near the joints. This means that the

mmf required by the joints is being supplied by the compensating windings and the mmf of coil M_1 is merely used for driving the flux through the bar specimen S_1 . The magnetizing force in the specimen is, therefore, $H = \frac{NI}{l}$

where N = number of turns of winding M_1 , I = current in M_1 , and l = length of bar S_1 .

The following procedure is adopted to obtain equal flux linkages with all the search coils.

The test specimen is demagnetized and the value of current in M_1 is adjusted to the required test value. The selector switch is put at position 1. In this position search coils a and c are connected in series, but in opposition, to a ballistic galvanometer. The currents in coils M_1 and M_2 are simultaneously reversed. A throw will be observed on the galvanometer. The current in coil M_2 is adjusted until no throw is obtained when the two currents are reversed. Since coils a and c have equal number of turns, this means equal fluxes are linking with them.

Now the selector switch is put at position 2. In this position coils a and b are connected in opposition with the galvanometer in the circuit. The current in the compensating winding is adjusted until the galvanometer shows no throw when currents in winding M_1 and the compensating windings are reversed simultaneously. Since coils a and b have the same number of turns, the flux linking with them is the same.

The flux density corresponding to the value of $(H = NI/l)$ in the winding M_1 can be measured by putting the selector switch at 3. At this position only coil a is connected across the ballistic galvanometer. The throw of the galvanometer is noted when the currents through magnetizing windings M_1 and M_2 and compensating windings A_1, A_2, A_3 and A_4 are simultaneously reversed.

The advantages of this permeameters are :

(i) This method results in uniform conditions along the specimen provided that the material itself is uniform.

(ii) This method can be used for magnetic testing of many kinds and also for calibration of specimens that serve as reference standards in some of the simpler methods.

In fact this permeameter has been used for magnetic measurements at the Bureau of Standards (U.S.A.) and in other laboratories and has been accepted as a standard by A.S.T.M.

The main disadvantages are :

1. The method described above does not take into account, the effects of any magnetic inhomogeneities in the specimen. Variations in permeability along the specimen result in magnetic leakage which cannot be compensated for and thus results in errors in measurements. Therefore, the method will give dependable results only when the test specimens are magnetically uniform.

2. In a Burrows permeameter the necessary adjustments for carrying out compensation are very tedious and slow, therefore, it is mainly used to determine the properties of uniform bars.

18'15. Fahy's Simplex Permeameter. This permeameter is commonly used for routine testing of magnetic materials. It consists of a single specimen in the form of a bar (Fig. 18'13). The specimen is clamped against a laminated steel yoke with the help of two iron posts. The yoke carries a magnetising winding. The specimen is wound uniformly with a search coil which extends over its entire active length. This search coil is connected to a ballistic galvanometer for the measurement of flux density and therefore this coil is known as 'B coil'. The magnetising force acting on the specimen is measured, like the flux density, by a ballistic galvanometer by connecting it across an air cored coil placed between the two clamping posts as shown. This search coil is known as 'H coil'. The values of magnetising force so measured is corrected by calibrating the 'H coil' using a specimen of known magnetic characteristics in place of the test specimen.

The advantages of a Fahy's permeameter are :

(i) It is simpler in both construction and operation as compared with Burrow's permeameter. The data may be acquired very rapidly.

(ii) It requires only test specimen.

(iii) It is less sensitive to the effects of magnetic inhomogeneities in the specimen. This is because the B coil is wound uniformly over the entire length of the specimen and therefore it tends to measure the average value of flux density in the specimen. Thus the effects of local magnetic irregularities are diluted.

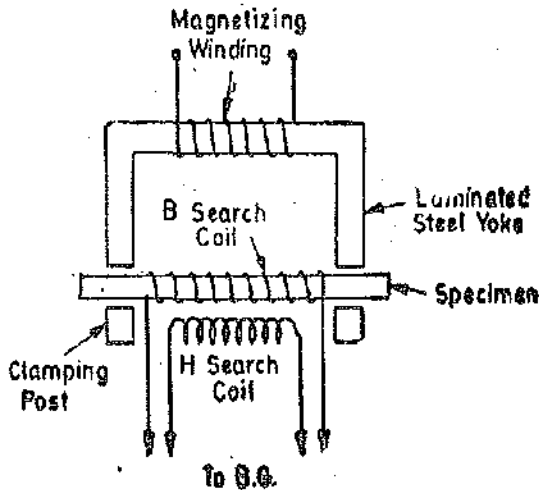

Fig. 18'13. Fahy's permeameter.

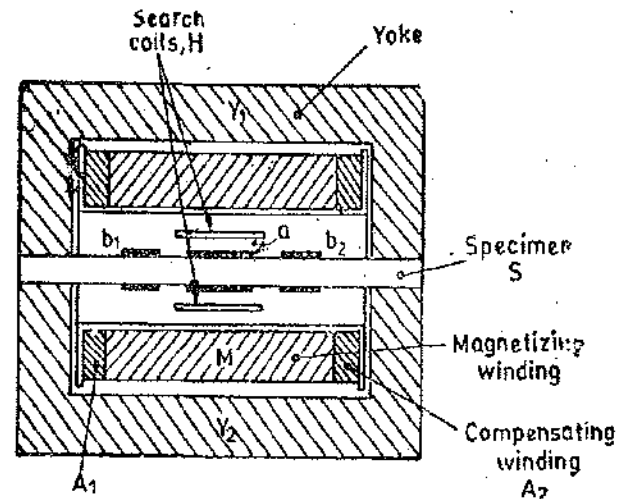

Fig. 18'14. National physical laboratory permeameter.

18'16. The National Physical Laboratory (England) form of Permeameter. This is one of the most accurate forms of permeameter and is comparatively easy to use in practice. The arrangement of the permeameter is shown schematically in Fig. 18'14. The specimen S may consist of a bundle of strips of 0.35 mm thick sheet iron, each strip being 25 cm long by 7 cm wide. The specimen is clamped between two similar rectangular iron yokes Y_1 and Y_2 which are in parallel in the magnetic circuit. The cross-sectional area of these yokes is large so that they present a low-reluctance path to the flux in the specimen. The yokes are often built with sheet laminations. The main magnetising winding M is wound on a bobbin which surrounds the specimen, and it is provided at each end with compensating windings A_1 and A_2 , whose purpose is to supply the mmfs necessary to overcome the reluctance of the joints. The flux density in the specimen is measured ballistically in the usual way by means of the small search coil surrounding the mid-section of the specimen. Two other coils b_1 and b_2 , each have half the number of turns in a and are used to check the uniformity in flux in the specimen in a manner similar to that described for the Burrow's permeameter. The compensation is carried out by connecting coils b_1 and b_2 in series, and in opposition to coil a to the ballistic galvanometer. The main magnetising current is adjusted to give the required value of H , and the currents in the compensating windings are then adjusted until there is no indication on the ballistic galvanometer when the main and compensating currents are simultaneously reversed. When the compensation is correct the flux density over the mid-section of the specimen is uniform. This flux density can be measured by connecting coil a by itself, to the ballistic galvanometer and noting the throw when the main and compensating currents are reversed. Compensation is not necessary with specimens of low relative permeability, *i.e.* below, 1,000.

The value of H in the specimen is measured in this permeameter by means of H coils. These coils are wound on thin rigid flat cards of insulating material, usually between 1 and 2 mm thick, of the same width as the specimen and between 5 and 8 cm long. The coils have a large number of turns of very fine copper wire, the number of turns being chosen to give adequate sensitivity with the ballistic galvanometer. When tests at low H values are being carried out, thousands of turns, wound in several layers, are necessary. Then windings are usually impregnated with wax or varnish, to give them rigidity. Two of these coils are normally used, one placed on each side of specimen, and if the flux density is uniform in the specimen, the flux through these coils will be proportional to the H in the specimen. The total flux linkages in the H coil in a field of strength H is $\mu_0 N A H$, where N is the

total number of turns and A the mean area of the turns. It is impossible to measure the product NA from the dimensions of the coil, and the H coils are usually calibrated with a long solenoid.

The actual measurement of H is carried out in the permeameter by connecting the H coils to the ballistic galvanometer after the B test, and reversing the main and compensating winding currents.

This permeameter may be taken as typical of modern precision permeameters as :

(i) This permeameter uses an H coil for determination of value magnetising force H instead of using a calculated value of H and these latter values are normally erroneous

(ii) This permeameter gives accurate results over a very wide range of magnetizing force.

This range extends from a small value of 10 A/m to a very high value of 300,000 A/m.

(iii) The field strength can be doubled by mounting a short specimen between massive soft iron pole pieces.

(iv) This permeameter is capable of even testing circular cross section specimens by addition of shaped pole pieces.

18'17. Measurement of Leakage Factor with Flux Meter. In an electrical machine the leakage factor is defined as :

$$\text{Leakage factor} = \frac{\text{total flux}}{\text{useful flux}}$$

Useful flux = flux in the armature (flux crossing the air gap).

Total flux = flux in the pole bodies = useful flux + leakage flux existing in the pole body at its root.

Thus in order to measure the leakage factor, we must measure the flux in the pole bodies and the flux in the armature.

The flux measurements are done by a flux meter. A ballistic galvanometer cannot be used here as the field windings of electric machines are highly inductive and therefore the flux changes very slowly when the voltage is impressed across the field winding.

It is clear from Fig. 18'15, that the yoke carries half of the total flux and therefore it is possible to measure the value of total flux per pole by using two search-coils on the yoke and connecting them in series across the flux meter. The armature is kept stationary and another search coil is put on it. This coil is so positioned that it embraces the useful flux per pole. This search coil is then connected to the flux meter and this way the useful flux is measured. Leakage factor can thus be calculated from the two readings of the flux meter.

Search coils of usually one turn are used so that the flux meter reading gives the flux directly.

In large machines, the value of flux is quite large and therefore it becomes necessary to use a shunt along-with the flux meter in order that its range may be increased.

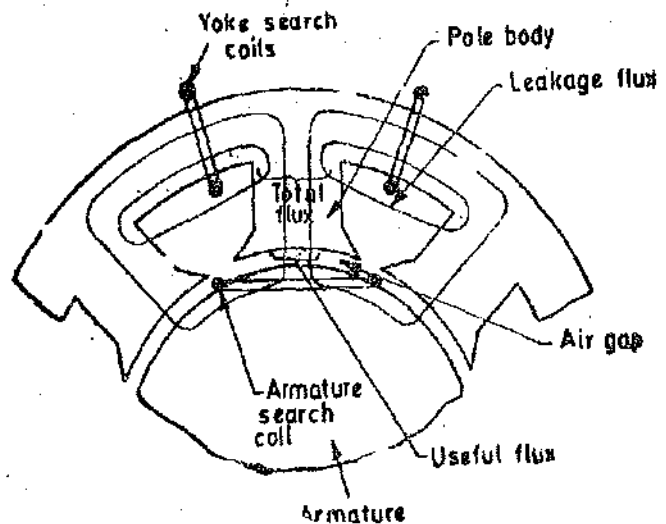

Fig. 18'15. Measurement of leakage factor.

Example. 18'1. An iron ring of 350 mm^2 cross-sectional area with a mean length of 1 m is wound with a magnetising winding of 100 turns. A secondary coil with 200 turns of wire is connected to a ballistic galvanometer having a constant of $1 \mu\text{C}$ per scale division, the total resistance of the secondary circuit being 2000Ω . On reversing a current of 10 A in the magnetising winding, the

galvanometer shows a deflection of 100 scale divisions. Calculate the flux density in the specimen, and the value of permeability at this flux density.

Solution. Total mmf of coil $= N_1 I_1 = 100 \times 10 = 1,000 \text{ A}$.

Magnetising force $H = N_1 I_1 / l = 1,000 / 1 = 1000 \text{ A/m}$.

Charge through the galvanometer $Q = K_d \theta_1 = 1 \times 100 = 100 \text{ } \mu\text{C}$.

Supposing Φ is the flux through the ring,

Flux linkages of search coil $\psi = N_2 \Phi = 200\Phi$.

Change in flux linkages of search coil due to reversal of current $\Delta\psi = 2\psi = 400\Phi$.

Average emf induced in the search coil $e = \frac{\Delta\psi}{\Delta t} = \frac{400\Phi}{\Delta t}$ where $\Delta t =$ time of reversal.

\therefore Current through search coil $i = \frac{e}{R} = \frac{400\Phi}{\Delta t \times R}$

Charge through the search coil circuit $Q = i \Delta t = \frac{400\Phi}{\Delta t \times R} \Delta t = \frac{400\Phi}{R} = \frac{400\Phi}{2000}$

Thus, $\frac{400\Phi}{2000} = 100 \times 10^{-6}$ or $\Phi = 500 \times 10^{-6} \text{ Wb}$

Flux density in the specimen $B = \frac{\text{flux}}{\text{area}} = \frac{500 \times 10^{-6}}{350 \times 10^{-6}} = 1.428 \text{ Wb/m}^2$.

Permeability of specimen $\mu = \frac{B}{H} = \frac{1.428}{1000} = 1.428 \times 10^{-3}$

\therefore Relative permeability of specimen $\mu_r = \frac{\mu}{\mu_0} = \frac{1.428 \times 10^{-3}}{4\pi \times 10^{-7}} = 1136$.

Example 18.2. An iron ring has a mean diameter of 0.1 m and a cross-section of 33.5 mm². It is wound with a magnetising winding of 320 turns and a secondary winding of 220 turns. On reversing a current of 10 A in the magnetising winding, a ballistic galvanometer gives a throw of 272 scale divisions, while a Hibbert magnetic standard with 10 turns and a flux of $0.25 \times 10^{-3} \text{ Wb}$ gives a reading of 102 scale divisions, other conditions remaining the same. Find the relative permeability of the specimen.

Solution. In a Hibbert's magnetic standard, the coil slides through the gap of a permanent magnet. (See page 102).

\therefore Change in flux linkages of the coil when it goes down the Hibbert's standard
 $= \text{flux} \times \text{turns of the Hibbert's standard's coil}$
 $= (0.25 \times 10^{-3}) \times 10 = 2.5 \times 10^{-3} \text{ weber turns}$.

Throw of galvanometer with Hibbert's standard = 102.

\therefore Constant of galvanometer $K_\phi = \frac{2.5 \times 10^{-3}}{102} = 24.5 \times 10^{-6} \text{ weber turns/division}$.

The galvanometer shows a deflection of 272 divisions when connected to search coil.

\therefore Change in the flux linkages of search coil $\Delta\psi = 272 \times 24.5 \times 10^{-6} = 6664 \times 10^{-6} \text{ weber turn}$.

This change in flux linkages is caused by reversal of flux.

\therefore Flux linkages of coil $\psi = \frac{\Delta\psi}{2} = 3332 \times 10^{-6} \text{ weber turn}$.

Flux linking with search coil	$\Phi = \frac{\text{flux linkages of coil}}{\text{turns of coil}} = \frac{33.32 \times 10^{-6}}{220} = 15.1 \times 10^{-6} \text{ Wb.}$
Flux density in specimen (ring)	$B = \frac{15.1 \times 10^{-6}}{33.5 \times 10^{-6}} = 0.452 \text{ Wb/m}^2.$
Length of flux path in ring	$l = \pi D = \pi \times 0.1 = 0.314 \text{ m.}$
Total mmf of magnetising winding	$= 320 \times 10 = 3200 \text{ A.}$
Magnetising force	$H = \frac{3200}{0.314} = 10,200 \text{ A/m}$
Relative permeability of specimen	$\mu_r = \frac{B}{\mu_0 H} = \frac{0.452}{4\pi \times 10^{-7} \times 10,200} = 35.2.$

Example 18.3. The constant of a given magnetic potentiometer is obtained by aid of a coil of 300 turns in which a current of 0.6 A is reversed. The resulting throw of the galvanometer is 157 scale divisions. It is then used to measure the magnetic potential difference between two points and the throw is 304 divisions. Find the magnetic potential difference.

Solution Mmf of coil $= 3000 \times 0.6 = 180 \text{ A.}$

Change in mmf due to reversal of current in the coil $= 2 \times 180 = 360 \text{ A.}$

A deflection of 157 scale divisions is caused by an mmf of 360 A.

\therefore Mmf causing a deflection of 304 divisions $= \frac{304}{157} \times 360 = 695 \text{ A.}$

Hence, magnetic potential difference $= 695 \text{ A.}$

Example 18.4 A ballistic galvanometer having a circuit resistance of 5000 Ω and a constant of 0.1 μC per scale division is connected in turn with a coil of 2 turns wound round the field coil of a d.c. machine, and one of 3 turns placed on the armature surface embracing total flux per pole entering the armature. When normal field current is broken the galvanometer readings are 113 and 136 divisions respectively. Calculate the flux per pole and leakage co-efficient.

Solution. Let Φ be a flux linking with a search coil of N turns.

\therefore Thus linkages of search coil $\psi = N\Phi.$

If the circuit producing the flux Φ is suddenly broken, the value of flux becomes zero. Therefore, the change in the value of flux linkages under these conditions is $\Delta\psi = \psi = N\Phi.$

$$\text{Emf induced } e = \frac{\Delta\psi}{\Delta t} = \frac{N\Phi}{\Delta t}$$

where $\Delta t =$ time taken by the flux to come down to zero.

$$\text{Current } i = \frac{e}{R} = \frac{N\Phi}{R\Delta t}, \text{ where } R = \text{resistance of search coil circuit.}$$

$$\text{Charge } Q = i\Delta t = \frac{N\Phi}{R}$$

But charge $Q = K_g\theta_1$, where $K_g =$ constant of galvanometer in coulomb/scale division.
 $\theta_1 =$ deflection of galvanometer in scale division.

$$\therefore K_g\theta_1 = \frac{N\Phi}{R} \text{ or Flux } \Phi = \frac{RK_g\theta_1}{N}$$

Armature Flux : Let $\Phi =$ armature flux per pole.

$$\therefore \Phi = \frac{RK_g\theta_1}{N} = \frac{5000 \times 0.1 \times 10^{-6} \times 136}{3} = 0.0226 \text{ Wb.}$$

Pole Flux : Let Φ_p be the total flux in each pole

$$\therefore \Phi_p = \frac{5000 \times 0.1 \times 10^{-6} \times 113}{3} = 0.0282 \text{ Wb.}$$

$$\therefore \text{Leakage factor} = \frac{\text{total flux per pole}}{\text{armature flux per pole}} = \frac{0.0282}{0.0226} = 1.25.$$

Example 18.5. A ferro-magnetic material is tested with the help of a permeameter provided with a coil wound over the specimen, this coil being known as 'B coil' and another coil wound near the surface of the coil called 'H coil'. These two coils are connected to two separate ballistic galvanometers having a constant of 25×10^{-6} weber.turn per scale division. The testing is done by reversing the current of the magnetizing winding wound over the specimen. The reading of the ballistic galvanometer connected to 'B' coil is 100 divisions and that connected to 'H' coil is 10 divisions. The data of the two coils is :

Coils	Turns	Area
B coil	100	$50 \times 10^{-6} \text{ m}^2$
H coil	10000	$5 \times 10^{-6} \text{ m}^2$

Find the flux density and magnetizing force in the specimen. Also find the relative permeability of the specimen.

Solution. Suppose Φ and N are the flux and the number of turns.

$$\therefore \text{Flux linkages } \psi = N\Phi,$$

Change in flux linkages due to reversal of current $\Delta\psi = 2\psi = 2N\Phi$.

Flux linkages indicated by galvanometer = $K_\phi \theta_1$

$$\therefore 2N\Phi = K_\phi \theta_1$$

$$\text{or Flux } \Phi = \frac{K_\phi \theta_1}{2N} \text{ and flux density } B = \frac{K_\phi \theta_1}{2NA}$$

'B' coil. Since 'B' coil is wound over the specimen, it gives the flux density in the specimen.

$$\therefore \text{Flux-density in specimen } B = \frac{K_\phi \theta_1}{2NA} = \frac{(25 \times 10^{-6}) \times 100}{2 \times 100 \times 50 \times 10^{-6}} = 0.25 \text{ Wb/m}^2.$$

'H' coil. This coil is put at the surface of the coil and hence indicates the flux density in the air.

$$\text{Flux density in air } B_0 = \frac{25 \times 10^{-6} \times 10}{2 \times 10000 \times 5 \times 10^{-6}} = 0.0025 \text{ Wb/m}^2.$$

$$\text{Magnetizing force, } H = \frac{B_0}{\mu_0} = \frac{0.0025}{4\pi \times 10^{-7}} \approx 2000 \text{ A/m.}$$

$$\text{Relative permeability } \mu_r = \frac{B}{\mu_0 H} = \frac{0.25}{4\pi \times 10^{-7} \times 2000} = 100.$$

ALTERNATING CURRENT MAGNETIC TESTING

18'18. Iron Loss Curves. When a magnetic material is subjected to an alternating field, loss in power occurs owing to hysteresis and eddy currents. This loss is called iron or core loss.

The hysteresis loss may be determined from the hysteresis loop obtained from d.c tests. But this hysteresis loss may be somewhat different under actual working alternating magnetization conditions. The eddy current loss can be measured only under a.c. conditions ; and it is usually convenient to measure the combined hysteresis and eddy current loss i.e., total iron loss.

Knowledge of total iron loss in ferro-magnetic materials is of considerable importance to designers. For comparison a single value of loss at a stated frequency (e.g., $f=50$ Hz) and a stated maximum flux density (e.g. $B=1.3$ Wb/m²) is sometimes sufficient. But in order to give complete information, family of curves called loss curves giving value of total iron loss per kg over a range of maximum flux density from zero to the higher value are usually given. Fig 18'16 shows loss curves for thickness $t=0.5$ mm and $t=0.3$ mm for a particular frequency say 50 Hz.

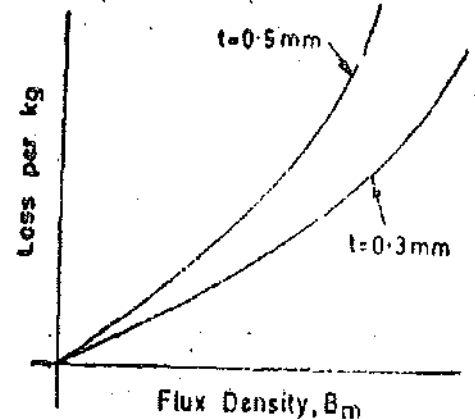

Fig. 18'16. Loss curves.

18'19. Separation of Iron Losses. In order to analyse the effects of differences of apparatus design or of metallurgical composition of different ferromagnetic materials, it is sometimes necessary to separate the total iron loss into hysteresis and eddy current components. Energy loss due to hysteresis in per unit volume is given by :

$$\int H dB = \text{area of hysteresis loop.}$$

Hysteresis loss per unit volume = frequency \times area of hysteresis loop.

Steinmetz gives the following formula for hysteresis loss :

$$\text{Hysteresis loss per unit volume } p_h = \eta f B_m^k \text{ watt} \quad \dots (18'10)$$

where η = hysteresis co-efficient ; f = frequency ; Hz,

B_m = maximum flux density ; Wb/m², and k = steinmetz co-efficient.

The value of k varies from 1.6 to 2.

$$\text{Eddy current loss per unit volume for laminations } p_e = \frac{4K_f^2 f^2 B_m^2 t^2}{3\rho} \text{ watt} \quad \dots (18'11)$$

where K_f = form factor, t = thickness of sheet ; m, and ρ = resistivity of material ; Ω m.

$$\therefore \text{ Total iron loss per unit volume } p_i = p_h + p_e = \eta f B_m^k + \frac{4K_f^2 f^2 B_m^2 t^2}{3\rho} \quad \dots (18'12)$$

Hence total iron loss in a given specimen of laminations is :

$$P_i = \text{volume} \times \left(\eta f B_m^k + \frac{4K_f^2 f^2 B_m^2 t^2}{3\rho} \right) \quad \dots (18'13)$$

For a particular specimen, volume, thickness t and resistivity ρ as are constants.

$$\therefore P_i = K_h B_m^k + K_e K_f^2 f^2 B_m^2 \quad \dots (18'14)$$

where K_h and K_e are constants.

As the hysteresis and eddy current losses have different laws of variation with both frequency and form factor K_f , it is possible to separate the losses by variation of frequency or of form factor if B_m can be maintained constant.

1. Variation of Frequency. The form factor K_f and maximum flux density B_m remain constant in this test. If the frequency is varied the total iron loss may be written as

$$P_i = K_1 f + K_2 f^2 \quad \dots(18'15)$$

where

$$K_1 = K \lambda B_m^2 \quad \dots(18'16)$$

and

$$K_2 = K_e K_f^2 B_m^2 \quad \dots(18'17)$$

Both K_1 and K_2 being constant for this test.

Now we have:
$$\frac{P}{f} = K_1 + K_2 f. \quad \dots(18'18)$$

Thus on plotting P_i/f against f , we obtain a straight line as shown in Fig. 18'17, the values of K_1 and K_2 can be obtained from intercept and slope of the line respectively.

2. Variation of Form Factor. The value of maximum flux density B_m and frequency f are kept constant in this test. If the form factor K_f is varied, the total iron losses may be written as :

$$P_i = K_3 + K_4 K_f^2 \quad \dots(18'19)$$

where

$$K_3 = K \lambda f B_m^2 \quad \dots(18'20)$$

and

$$K_4 = K_e f^2 B_m^2 \quad \dots(18'21)$$

Both K_3 and K_4 being constant for this test. Thus on plotting P_i against K_f^2 , we obtain a straight line as shown in Fig 18'18. The values of K_3 and K_4 can be obtained from its intercept and slope of the straight line respectively.

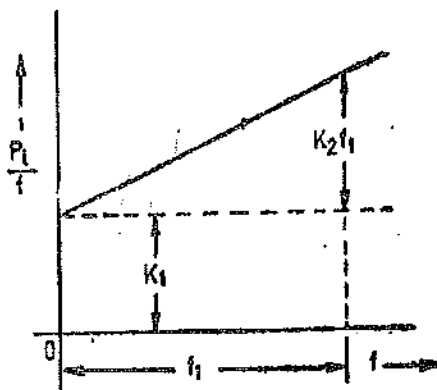

Fig. 18'17. Variation of iron loss with frequency.

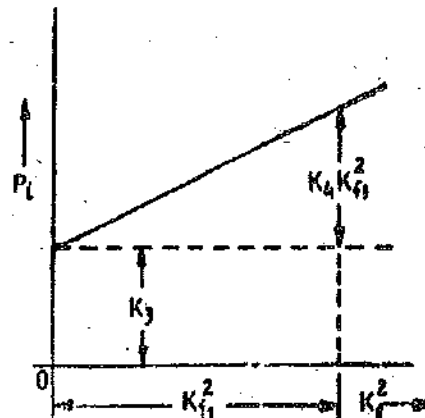

Fig. 18'18. Variation of iron loss with K_f^2 .

18'20. Methods of Iron Loss Measurement. There are three types of methods used for measurement of iron loss in ferro-magnetic materials

(i) Wattmeter method, (ii) Bridge method, and (iii) Potentiometer method.

18'21. Wattmeter Method. This method is most commonly used for measurement of iron loss in strip (sheet) material. The strip material to be tested is assembled as a closed magnetic circuit in the form of a square. Therefore this arrangement is known as a magnetic square. There are two common forms of these magnetic squares.

1. Epstein Square. In this square there are four stacks of strips. These stacks are bound and then taped. The individual strips are insulated from each other and each strip is in the plane of the square. The stacks are slipped into four magnetising coils with the strips projecting beyond the coils.

The ends of the four strips are interleaved (as in transformer core construction) and clamped at corners. The arrangement of an Epstein square is shown in Fig. 18'19.

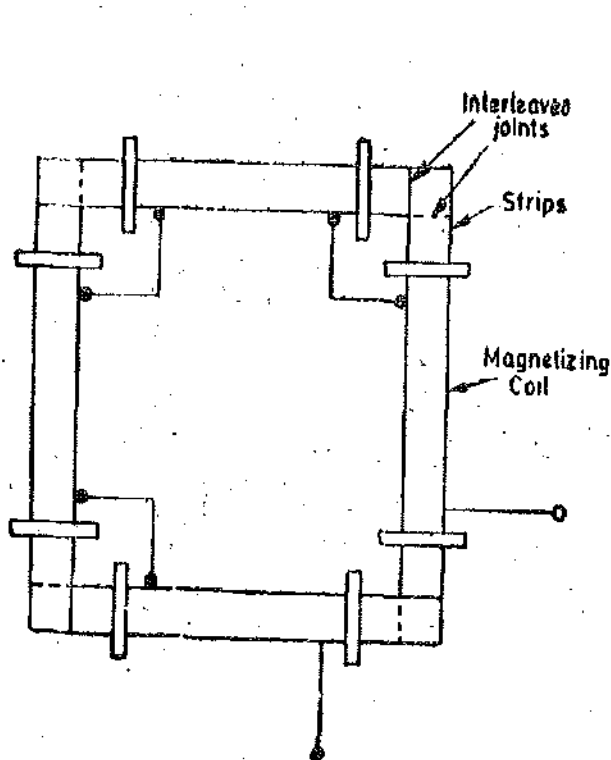

Fig. 18'19. Epstein square.

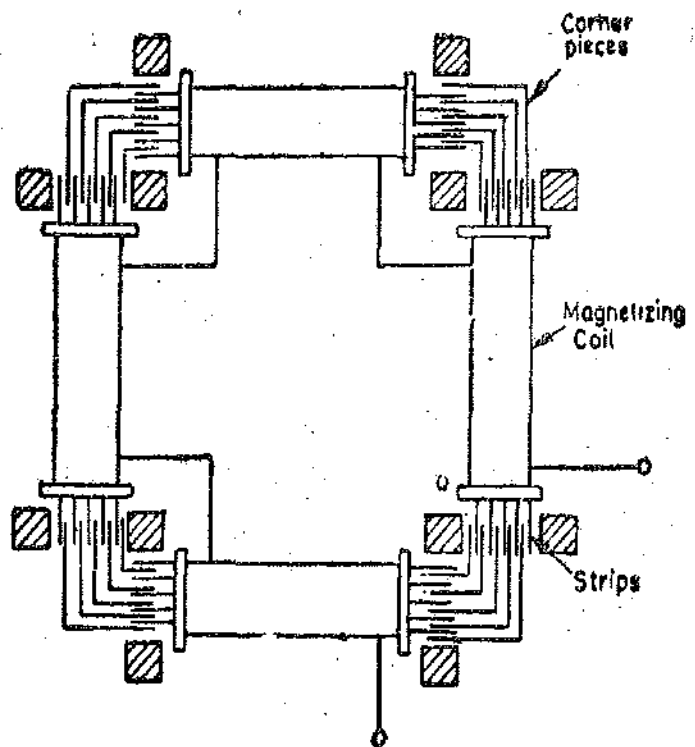

Fig. 18'20. Lloyd-Fisher square.

2. Lloyd-Fisher Square. This is the most commonly used magnetic square and therefore it is described in greater details. The strips used are usually 0.25 m long and 50 to 60 mm wide. These strips are built up into four stacks. Each stack is made up of two types of strips one cut in the direction of rolling and the other cut perpendicular to the direction of rolling.

The stacks of strips are placed inside four similar magnetising coils of large cross-sectional area. These four coils are connected in series to form the primary winding.

Each magnetising coils has two similar single layer coils underneath it. They are called secondary coils. Thus in a magnetic square there are eight secondary coils. These secondary coils are connected in series in groups of four, one from each core, to form two separate secondary windings.

The ends of the strips project beyond the magnetising coils. The strips are so arranged that the plane of each strip is perpendicular to the plane of the square. The magnetic circuit is completed by bringing the four stacks together in the form of a square and joining them at the corners. The corner joints are made by a set of standard right angled corner pieces as shown in Fig. 18'20. The corner pieces are of the same material as strips or at least a material having the same magnetic properties. There is an overlapping of corner pieces and strips at the corners due to which cross-section of iron is doubled at the corners. Therefore, a correction must be applied for this. Also the measured loss has to be corrected for the loss in the corner pieces.

Advantages. 1. In case allowance for corner pieces is known with sufficient accuracy, the Lloyd-Fisher square gives rather more reliable results than the Epstein square.

In the case of an Epstein square, the value of flux density in the corners is quite different from that of the square, and an allowance of this is difficult to make.

2. The Epstein square is also inferior for tests on anisotropic materials as the direction of flux at the corners is partially perpendicular to the path of flux in other portions of the strip. The use of corner pieces in a Lloyd-Fisher square makes it superior for testing anisotropic materials.

Test set up. The test specimen is weighed before assembly and its effective cross-section is determined. The primary winding is connected to a sinusoidal voltage supply. Fig 18'21 shows the connection diagram for finding the total iron loss by wattmeter method.

The primary winding contains the current coil of the wattmeter. The pressure coil of the wattmeter is supplied from one of the secondary windings. The wattmeter is designed for low power factor operation as the power factor is usually about 0.2. The second secondary winding supplies an electrostatic voltmeter (or an electrodynamic voltmeter of very high impedance). The frequency of supply is adjusted to the correct value.

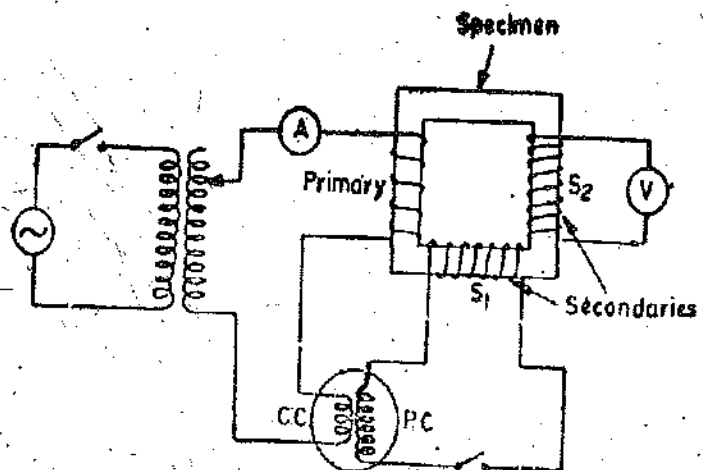

Fig. 18'21. Wattmeter method for determining iron loss.

The voltage applied to the primary winding is adjusted, preferably with the help of a variable ratio transformer, till the magnetising current is adjusted to give the required value of B_m . The wattmeter and voltmeter readings are observed.

Theory. The electrostatic voltmeter connected across secondary winding S_2 measures the rms value of induced voltage. This value of induced voltage is

$$E = 4 K_f \Phi_m f N_2 = 4 K_f B_m A_s f N_2$$

where

K_f = form factor (1.11 for sinusoidal waves),

Φ_m = maximum value of flux ; Wb,

B_m = maximum value of flux density ; Wb/m²,

A_s = cross-sectional area of specimen ; m²,

f = frequency ; Hz,

and

N_2 = number of turns in the secondary winding S_2 .

$$\therefore \text{Maximum value of flux density } B_m = \frac{E}{4 K_f A_s f N_2}$$

This value is thus the apparent value B_m' of the flux density.

Correction must be applied to this value of flux density as the secondary winding S_2 encloses the flux in the air space between specimen and the coil in addition to the flux in the specimen, as discussed earlier on page 571.

The actual value of flux density in the specimen (Eqn. 18'2) is

$$B_m = B_m' - \mu_0 H_m \left(\frac{A_s}{A_c} - 1 \right) \quad \dots (18'22)$$

where

A_c = cross-sectional area of coil.

and

H_m = magnetising force corresponding to maximum flux density. This may be taken from the B - H curve of the specimen.

The wattmeter reading includes both the iron loss in the specimen and the copper loss in the secondary winding circuit. The copper loss in the secondary winding can be calculated and subtracted from the wattmeter readings.

Let P_i = total iron loss, P = wattmeter reading,

V = voltage applied to wattmeter pressure coil,

E = voltmeter reading = voltage induced in S_2 ,

r_p = resistance of wattmeter pressure coil, r_s = resistance of coil S_1 ,
and I_p = current in the pressure coil circuit.

Now, voltage induced in S_1 is equal to the voltage induced in S_2 since both of them have equal number of turns and they link with the same flux.

\therefore Voltage induced in $S_1 = E$

The leakage reactances of winding S_1 and that of pressure coil are very small as compared with resistance of the pressure coil circuit. If we neglect the leakage reactances of winding S_1 and pressure coil, we have

$$E = I_p(r_p + r_s).$$

\therefore Total iron loss in specimen + total copper loss in the secondary winding circuit = PE/V

Total copper loss in the secondary winding circuit = $E^2/r_p + r_s$

\therefore Total iron loss in the specimen $P_i = P \frac{E}{V} - \frac{E^2}{r_p + r_s} = P \left(1 + \frac{r_s}{r_p} \right) - \frac{E^2}{r_p + r_s}$... (18 23)

Specific iron loss i.e., iron loss per kg can be calculated by dividing the total iron loss by the weight of the specimen.

The eddy current and hysteresis components of the iron loss can be determined from results of the loss measurements at different frequencies.

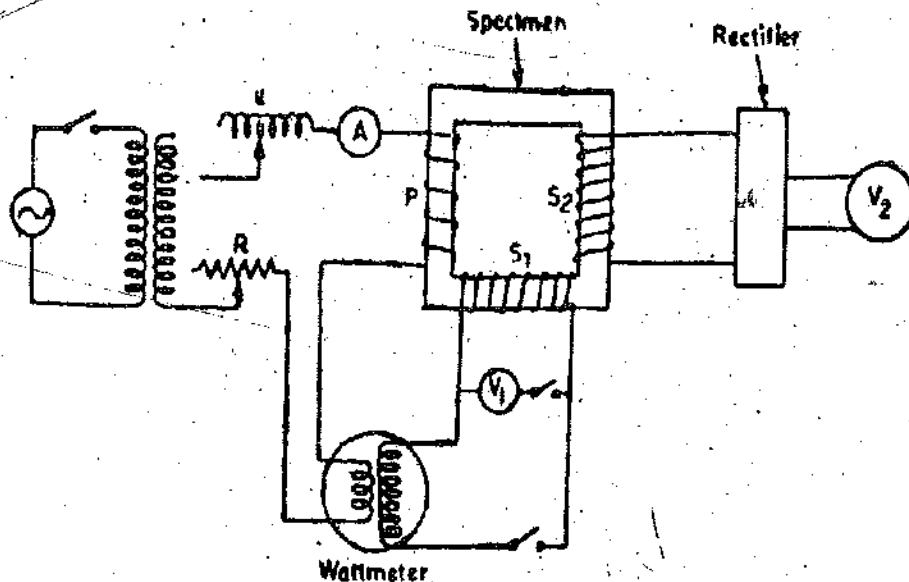

Fig. 18-22. Wattmeter method for testing at various form factors.

Fig. 18-22 shows the connections for the measurement of iron loss at different form factors. The form factor is obtained from the readings of two voltmeters V_1 and V_2 . Voltmeter V_1 is connected across S_1 may be an electrostatic or an electro-dynamometer type and therefore it reads the rms value of the voltage. Voltmeter V_2 connected across S_2 is a moving coil instrument supplied through a bridge rectifier and therefore it reads the average value of voltage.

$$\text{Form factor } K_f = \frac{\text{rms value}}{\text{average value}} = \frac{\text{reading of } V_1}{\text{reading of } V_2}$$

(as S_1 and S_2 have equal number of turns).

Variation of form factor is obtained by adjusting the values of series resistance and inductance.

3. Wattmeter method for testing ring specimens. Sheet steel in the form of rings is used for making current transformers. Also spiral cores used are for the construction of current transformers and variacs. Therefore it becomes necessary to measure iron loss in ring-specimens. The methods employed and the experimental set up is the same as that for strips. Fig. 18-23 shows the connection

diagram for measurement. S_1 and S_2 are two secondary windings, V_1 is a voltmeter which reads the rms value while voltmeter V_2 reads the average value of voltage.

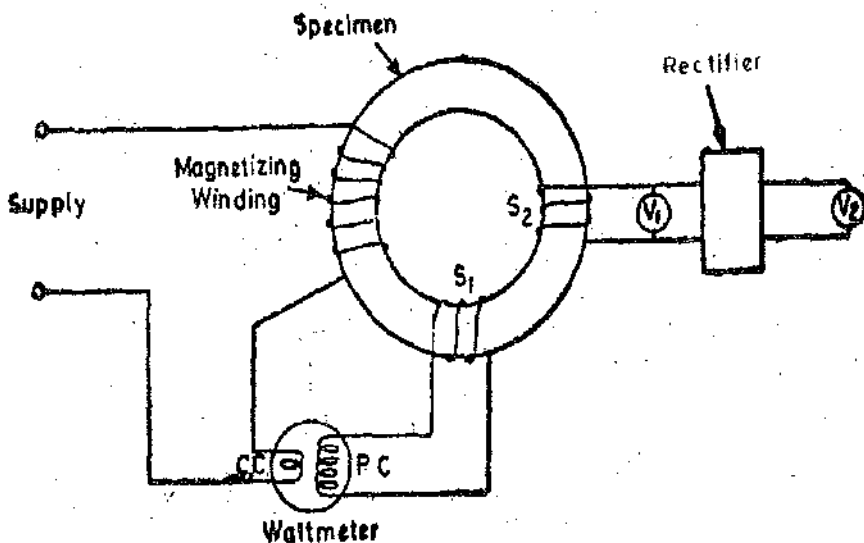

Fig. 18'23. Wattmeter method testing of ring specimens.

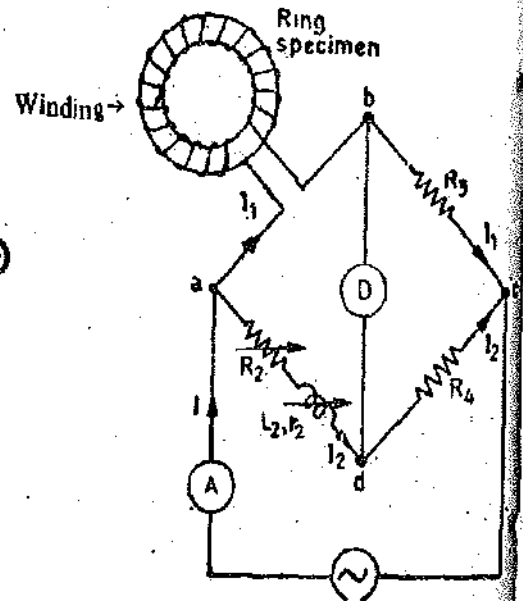

Fig. 18'24. Maxwell's bridge for testing ring specimen.

18'22. Bridge Methods. The wattmeter method described above is not sufficiently sensitive for testing sheet material working at low flux densities frequently employed in communication equipment. For materials working at low flux densities, a.c. bridge or a.c. potentiometer methods are suitable.

A number of bridge circuits may be used for measurement of iron loss and a.c. permeability. They are not only useful where materials work at low flux densities, but also where only a small quantity of material is available for testing and the test is to be carried out at commercial or audio frequencies.

1. Maxwell's Bridge. The connection diagram of the Maxwell's bridge for the measurement of iron loss and permeability of a ring type specimen is given in Fig. 18'24. The theory of this bridge is given in Art. 16.5.

The specimen is connected in arm a, b .

Let the effective resistance of ab be R_s and the effective inductance be L_s .

$$\therefore \text{From Eqn. 16'17, } R_s = \frac{R_3}{R_4} (R_2 + r_2).$$

Now effective resistance of arm ab is

$$R_s = \frac{\text{iron loss} + \text{copper loss in winding}}{\text{current}^2} = \frac{P_i + I_1^2 R_w}{I_1^2} \quad \dots(18'24)$$

where R_w = resistance of winding of coil

$$\therefore \text{Iron loss } P_i = I_1^2 (R_s - R_w) \quad \dots(18'25)$$

At balance voltage drop between bc and dc are equal.

$$\therefore I_1 R_3 = I_2 R_4 = (I - I_1) R_4 \text{ as } I = I_1 + I_2 \quad \text{or } I_1 = \frac{R_4}{R_3 + R_4} I.$$

\therefore From Eqn. 18'25, we get

$$\text{Iron loss } P_i = I^2 \left(\frac{R_4}{R_3 + R_4} \right)^2 (R_s - R_w)$$

The value of iron loss may be calculated as the value of R_s is known from Eqn. 16.

The value of I can be measured and resistance, R_w , of the winding may be measured with d.c.

From Eqn. 16'16 Inductance of specimen $L_s = \frac{R_3}{R_4} L_2$

But inductance $L_s = \frac{N^2}{l_s/\mu_s A_s}$

where N = number of turns of magnetising winding,

l_s = length of mean flux path in specimen,

A_s = area of specimen,

and μ_s = a.c. permeability of specimen.

\therefore A.C permeability $\mu_s = \frac{l_s L_s}{N^2 A_s} = \frac{l_s R_3 L_2}{N^2 A_s R_4}$... (18'26)

2. Campbell's Bridge Method. This is one of the best known methods for iron loss measurement by bridge networks.

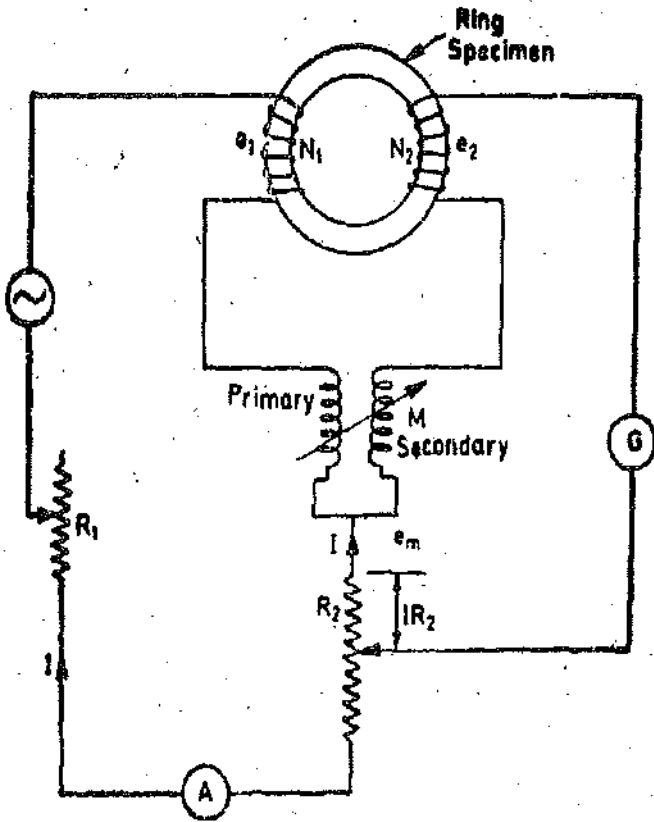

Fig. 18'25. Campbell's Bridge method for testing ring specimens.

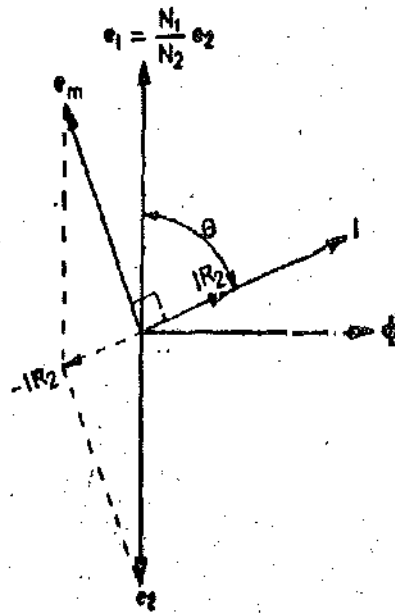

Fig. 18'26. Phasor diagram for Campbell Bridge.

The ring specimen carries two windings, one primary and one secondary, having the same cross-sectional area. M is a variable mutual inductance connected as shown in Fig. 18'26. R_1 and R_2 are variable resistances. The balance is obtained by varying M and R_2 .

The phasor diagram under balance conditions is shown in Fig. 18'26. Φ is the flux in the specimen, I is the current in the primary winding of the specimen. On account of iron loss, I leads the flux by a small angle. e_1 and e_2 are respectively the induced voltages in primary and secondary windings of the specimen, e_m is the induced voltage in the secondary winding of the mutual inductance M .

Consider the circuit on secondary winding side. Balance is obtained when phasor sum of e_m and e_2 is equal and opposite to the phasor IR_2 .

Let M' = mutual inductance between the primary and secondary windings on the specimen.

$\therefore e_2 = \omega M' I$ and $e_m = \omega M I.$

Since IR_2 is very small, we can write $e_2 \approx e_m$
 or $\omega M' I \approx \omega M I$ or $M' \approx M.$

Flux in the specimen $\Phi = \frac{N_1 I}{l_0 / \mu_s A_s} = \frac{N_1 I \mu_s A_s}{l_0}$

Mutual inductance between primary and secondary windings of specimen is :

$M' = \frac{N_2 \Phi}{I} = \frac{N_1 N_2 \mu_s A_s}{l_0}$

But $M' = M. \therefore M = \frac{N_1 N_2 \mu_s A_s}{l_0}$

or a.c. permeability $\mu_s = \frac{M l_0}{N_1 N_2 A_s} \dots(18'27)$

Iron loss^l $P_t = e_1 I \cos \theta = e_1 I \cdot \frac{IR_2}{e_2} = I^2 R_2 \frac{e_1}{e_2}$

But $\frac{e_1}{e_2} = \frac{N_1}{N_2} \therefore P_t = I^2 R_2 \frac{N_1}{N_2} \dots(18'28)$

Current I is measured with the help of ammeter A and thus the iron loss can be computed.

18'23. A.C. Potentiometer Method. An a.c. potentiometer can also be used for the determination of iron loss and a.c. permeability of ferro-magnetic materials working at low flux densities. A.C. potentiometers have been described in Chapter 14.

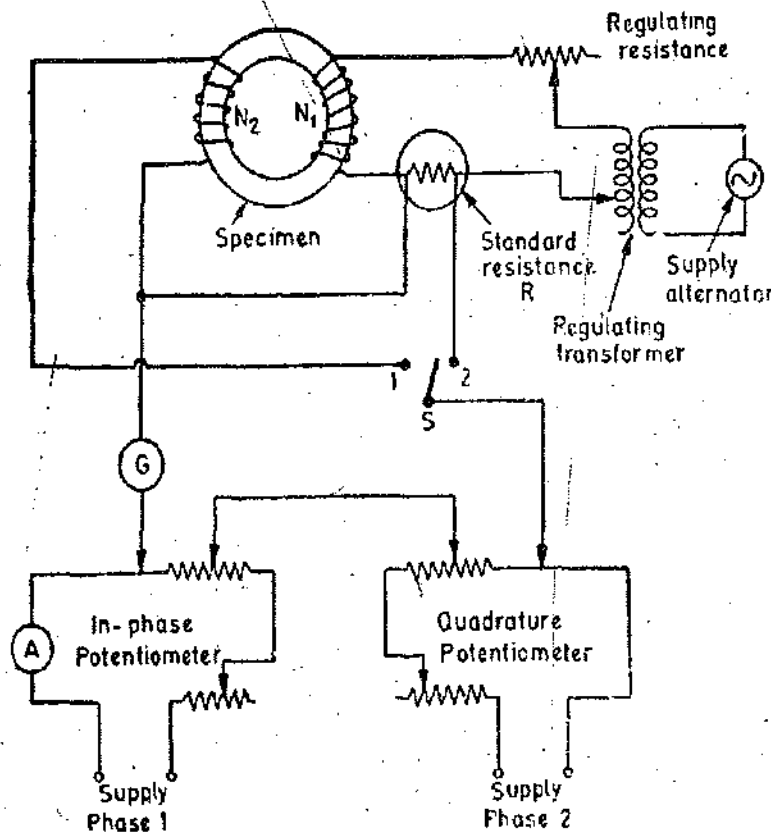

Fig. 18'27. A.C. potentiometer method of testing ring specimens.

The connections for iron loss measurement with a potentiometer are given in Fig. 18'27. The potentiometer is of Co-ordinate type.

The ring specimen carries two windings. The primary winding has N_1 turns and the secondary N_2 turns. The primary winding is supplied from an alternator through a regulator transformer. This alternator supplies the two potentiometer slide wire circuits also. The primary winding circuit has a regulating resistance. A standard resistor R is connected in series with the primary winding. This resistor is introduced in the circuit for the purpose of measuring the current in the primary winding by measuring the potential drop across it. G is a vibration galvanometer.

The potentiometer is standardized first. The supply is given to the primary winding of the specimen. A voltage E_2 is induced in the secondary winding.

$$E_2 = 4K_f f \Phi_m N_2 = 4K_f f B_m A_s N_2$$

where K_f = form factor = 1.11 for sinusoidal supply, f = frequency,
 B_m = maximum flux density, A_s = cross-sectional area of specimen,
 and N_2 = number of turns in the secondary winding.

∴ Maximum flux density

$$B_m = \frac{E_2}{4K_f A_s N_2} = \frac{E_2}{4.44 f A_s N_2} \text{ for sinusoidal supply.}$$

The voltage E_2 is measured by putting the switch S on contact 1, setting the quadrature potentiometer at zero and adjusting the inphase potentiometer till balance is obtained. The setting of inphase potentiometer gives the value of E_2 directly.

Switch S is then put on contact 2. At this position the potential drop in the standard resistance R is matched against the inphase and quadrature potentiometers. These potentiometers are adjusted to give balance condition.

The reading of inphase potentiometer gives the value of $I_c R$ where I_c is the loss component of the current in the primary winding :

$$I_c = \frac{\text{reading of inphase potentiometer}}{R}$$

The reading of quadrature potentiometer gives the value of $I_m R$ where I_m is the magnetising component of current in the primary winding.

$$I_m = \frac{\text{reading of quadrature potentiometer}}{R}$$

Potentiometer method is very suitable for a.c. magnetic testing at low flux densities since magnetising and iron loss components of exciting current are measured separately.

18'24. Oscillographic Method. Fig. 18'28 shows arrangement used for making magnetic measurements by a cathode-ray oscillograph. Two coils are wound on the ring test specimen. Magnetising winding N_1 and a small non-inductive resistor r_1 are connected to supply through an auto-transformer.

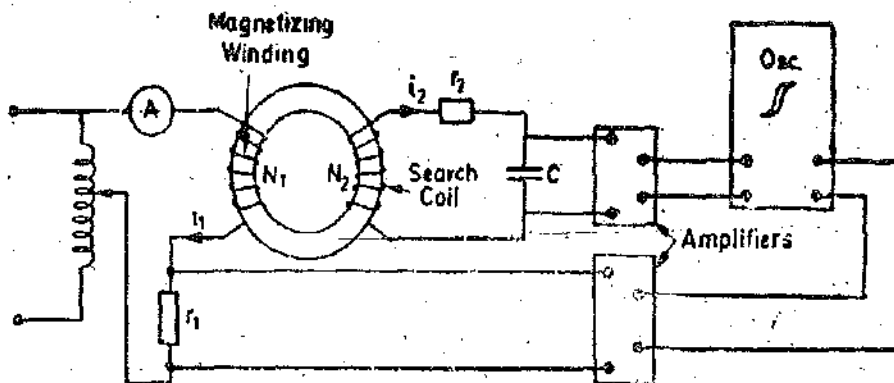

Fig. 18'28. Testing of magnetic material with oscillograph.

Voltage $v_1 (=i_1 r_1)$ across resistance r_1 is directly proportional to magnetising current i_1 and, consequently, to the strength of the magnetic field in the test specimen. This voltage v_1 is applied to the Y plates through an amplifier.

Search coil N_2 is shunted by a capacitor C and a high resistance r_2 .

The emf induced in the search coil is given by

$$e_2 = N_2 \frac{d\Phi}{dt} = N_2 A_s \frac{dB}{dt}$$

When resistance r_2 is higher than that of the remaining section of the circuit, the current in the measuring circuit is :

$$i_2 = \frac{e_2}{r_2} = \frac{N_2 A_s}{r_2} \frac{dB}{dt}$$

The voltage across capacitor C is :

$$v_c = \frac{1}{C} \int i_2 dt = \frac{1}{C} \frac{N_2 A_s}{r_2} \int dB = \frac{1}{C} \frac{N_2 A_s}{r_2} B.$$

Therefore voltage v_c across the capacitor C is proportional to the flux density in the test specimen. This voltage v_c is applied to Y plates of the oscilloscope through an amplifier. The X -deflection is proportional to the voltage drop across resistance r_1 carrying the magnetising current, the deflection is therefore proportional to the magnetising force H .

The Y deflection is proportional to voltage v_c and therefore to the flux density B in the specimen.

1. **Plotting of Hysteresis Loop.** With the arrangement shown, the X -deflection is proportional to H and the Y -deflection is proportional to B . Thus the figure traced on the screen will be the hysteresis loop of the material.

2. **Plotting of B-H curve.** If the peak flux density in the specimen is slowly and continuously varied (e.g., by varying the excitation of the alternator supplying the magnetising current) the locus of the tips of the hysteresis loops gives the B - H curve for the material.

3. **Determination of Hysteresis Loss.** The hysteresis loss for the material may be estimated from the area of the loop either by comparison with a loop for a standard specimen or by calculation from the X and Y sensitivities of the cathode-ray oscilloscope and the circuit constants.

Further, it must be realized that the current flowing through r contains a component associated with the eddy-current loss in the specimen. Thus the loop obtained is really a 'total-loss' loop whose area represents the total iron loss. The method is normally used for such purposes as acceptance tests, where the loop obtained may be compared with a standard loop.

Example 18.6. A manufacturer lists grain oriented steel sheet 0.3 mm thick. The resistivity of material is $50 \times 10^{-8} \Omega \text{ m}$. The hysteresis loop is essentially rectangular in form, with a coercive force of 12 A/m for all peak values of flux densities between 0.8 to 1.6 Wb/m². A sinusoidal flux density of 1 Wb/m² (peak) at 100 Hz is used. The density of material is 7650 kg/m³. Find the total loss/kg.

Solution. Base of hysteresis loop = $2H_c = 2 \times 12 = 24 \text{ A}$.

Ordinate of hysteresis loop = $2B_m = 2 \text{ Wb/m}^2$.

Area of hysteresis loop represents the loss per cycle.

\therefore Hysteresis loss per cycle = $24 \times 2 = 48 \text{ J}$.

Hysteresis loss = area of loop \times frequency = $48 \times 100 = 4800 \text{ W}$.

This loss is in 1 m^3 of volume.

Eddy current loss per unit volume = $\frac{4K^2 f^2 B_m^2 t^2}{3\rho} = \frac{4 \times (1.11)^2 \times (100)^2 \times (1.0) \times (0.3 \times 10^{-3})^2}{3 \times 50 \times 10^{-8}}$
 $= 2970 \text{ W}$.

This loss is in 1 m^3 of volume.

$$\therefore \text{Total loss/m}^3 = 4800 + 2970 = 7770 \text{ W.}$$

$$\text{Total loss/kg} = \frac{7770}{7650} = 1.03 \text{ W.}$$

Example 18.7. In a test on a specimen of total weight 13 kg the measured values of iron loss at a given value of peak flux density were 17.2 W at 40 Hz and 28.9 W at 60 Hz. Estimate the values of hysteresis and eddy current losses in W/kg at 50 Hz for the same value of peak flux density.

Solution.

$$\text{Eddy current loss } p_e = K_e f^2 B_m^2 \text{ W/kg.}$$

$$\text{Hysteresis loss } p_h = K_h f B_m^2 \text{ W/kg.}$$

Since B_m is constant, we can write :

$$p_h = K_1 f, \quad \text{and} \quad p_e = K_2 f^2.$$

$$\therefore \text{Total iron loss 1 kg } p_i = p_h + p_e = K_1 f + K_2 f^2$$

Substituting the values of iron loss per kg at 40 and 60 Hz, we have,

$$\frac{17.2}{13} = K_1(40) + K_2(40)^2 \quad \dots(i)$$

$$\text{and} \quad \frac{28.9}{13} = K_1(60) + K_2(60)^2 \quad \dots(ii)$$

From (i) and (ii) we get

$$K_1 = 0.0254 \quad \text{and} \quad K_2 = 0.000194.$$

$$\text{Eddy current loss per kg at 50 Hz} = K_2 f^2 = 0.000194 (50)^2 = 0.485 \text{ W.}$$

$$\text{Hysteresis loss per kg at 50 Hz} = K_1 f = 0.0254 \times 50 = 1.27 \text{ W.}$$

Example 18.8. A specimen of iron stampings weighing 10 kg and having a cross-sectional area of 1680 mm^2 is tested by an Epstein square shown in Fig. 18.19. Each of the two windings S_1 and S_2 have 515 turns. A sinusoidal voltage supply at 50 Hz is given to the primary winding of the Epstein square and an ammeter connected in the primary circuit indicates a current of 0.35 A and the electrostatic voltmeter connected across a secondary winding indicates a voltage of 250 V. The resistance of each of the windings S_1 and S_2 is 40Ω . The resistance of the pressure coil of the wattmeter is $80,000 \Omega$. Calculate the value of flux density in the specimen and the iron loss/kg at this flux density if the wattmeter connected on the primary side indicates 80 W.

Solution. Maximum flux density in the specimen

$$B_m = \frac{E}{4.44 f A_s N_s} = \frac{250}{4.44 \times 50 \times 1680 \times 10^{-6} \times 515} = 1.3 \text{ Wb/m}^2.$$

$$\text{Total loss } P = 80 \text{ W.}$$

$$\begin{aligned} \therefore \text{Iron loss in stampings } P_i &= P \left(1 + \frac{r_s}{r_p} \right) - \frac{E^2}{r_p + r_s} \quad (\text{see Eqn. 18.23}) \\ &= 80 \left(1 + \frac{40}{80,000} \right) - \frac{(250)^2}{40 + 80,000} = 79.26 \text{ W.} \end{aligned}$$

$$\text{Iron loss/kg} = \frac{79.26}{10} = 7.926 \text{ W/kg.}$$

18.25. Methods of Measurements of Air Gap Flux. Measurements described in preceding sections involve changes of magnetization. Such changes may not be always possible and measurements of an unvarying field must then be made. These measurements sometimes involve

measurement of very weak fields *e.g.*, of the earth's field in geomagnetic surveys and sometimes fields of very large strength *e.g.* fields of powerful electromagnets. Such measurements are always of the field in air gap. The range of these measurements is very large and therefore we have to select suitable method for the measurement. Some of the methods are :

- (i) Deflection of a pivoted magnetic needle—the classical magnetometer method.
- (ii) The rapid rotation of a search coil through 180° —*e.g.*, the classical earth inductor.
- (iii) Continuous rotation of a search coil fitted with a commutator to give a d.c. output.
- (iv) Continuous rotation of search coil fitted with slip-rings to give an a.c. output.
- (v) The force on a current-carrying conductor in the field.
- (vi) The effect of the field on the magnetization of a small piece of soft iron excited by a.c. in a magnetising winding.

There are a few more methods which are described in details below :

1. **Measurement of Field Strength by withdrawal of Search Coil.** In this method a search coil is placed in a magnetic field. The terminals of the search coil are connected to a ballistic galvanometer. This search coil is suddenly withdrawn from the magnetic field, with the result the flux linking with the search coil changes. This induces an emf in the search coil which causes the galvanometer to deflect. From the throw of the galvanometer the flux density in the field may be known.

2. **Measurement of constant field strength by Nuclear Magnetic Resonance.** When an alternating magnetic field of high frequency is superimposed on atomic nuclei located in a constant magnetic field, resonance absorption of energy from the high-frequency field is liable to occur at a specific ratio of the constant field strength H to frequency f of the alternating field.

The laws of quantum mechanics postulate that the magnetic moment of, say, the hydrogen nucleus (proton) may be oriented either in the same direction as that of the external magnetic field or in opposition to it.

The orientation of the proton magnetic moment can be changed by application of an energy quantum hf , where h is Plank's constant and f is frequency.

The difference between these two energy states of the proton amounts to $2m_p H$ where m_p is the proton magnetic moment.

Evidently, $hf = 2m_p H$ from which it follows that :

$$\omega = 2\pi f = \frac{4\pi}{h} m_p H = \nu_p H \quad \text{or} \quad H = \frac{2\pi f}{\nu_p} \quad \dots(18.29)$$

where ν_p is the gyromagnetic ratio of nucleus, *i.e.*, the ratio of the magnetic moment to the mechanical moment.

The gyromagnetic ratio of the nucleus of a number of substances is known to the nearest thousandth of a per cent. According to this method the magnetic strength of a constant field is determined by measuring the frequency at which nuclear magnetic resonance occurs. The block diagram of the test installation used for this purpose is shown in Fig. 18.29.

A proton sample, for example, an aqueous solution of $F_2(NO_3)_3$ contained in a glass ampoule is surrounded by a small coil and inserted in the magnetic field to be measured, the axis of the coil being at right angles to the field. The coil and capacitor constitute an oscillatory circuit, which is connected to a high frequency oscillator.

Resonance is detected by a sharp change in the amplitude of the resonance curve traced on the screen of the cathode-ray oscillograph at a change in the oscillator frequency. The resonance frequency is measured by means of a frequency meter or wavemeter. This method is most suitable for measurement of fields having a magnetic strength of 800 to 16×10^5 A/m. The accuracy of measurement lies within ± 0.01 per cent.

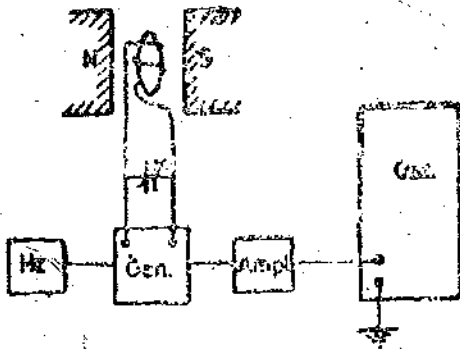

Fig. 18'29. Measurement field strength by nuclear magnetic resonance.

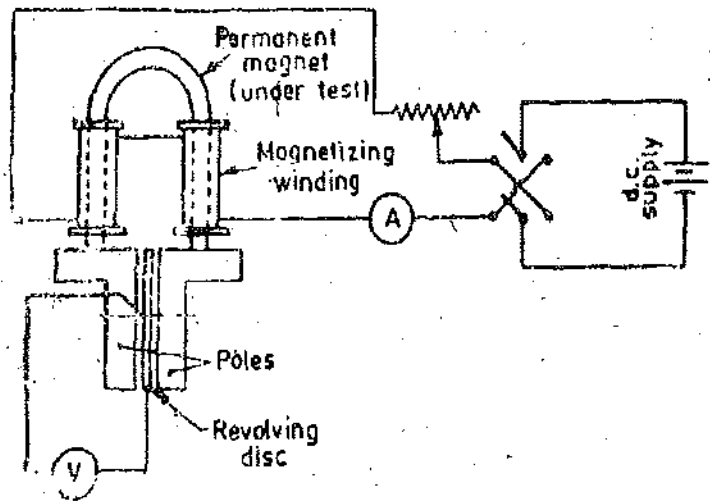

Fig. 18'30. Betteridge apparatus.

18'26. Testing of Permanent Magnets. The details of the method of testing permanent magnets, when manufactured, depend upon the shape of the magnet. This varies greatly according to the purpose for which the magnet is to be used. Owing to the self-demagnetizing force in permanent magnets, it is necessary, in testing such magnets, to measure H by means of search coils, of small cross-section, laid flat against the surface of the magnet. These search coils give the value of the air flux density at the surface of the magnet at different points, and search coils *i.e.*, B coils in the ordinary way.

Betteridge Apparatus for Magnet Testing. The principle of this apparatus for the commercial testing of permanent magnets may be followed from Fig. 18'30. The magnet to be tested is placed with its straight ends inside two magnetising coils and so that its ends press against two pole pieces, in the air gap between which a thin iron disc, plated with copper, is mounted. This disc is mounted in ball bearings and the clearances between it and the pole pieces are small. It is driven round at constant speed by a small motor, and has two small brushes making contact with its spindle and its rim. When a current flows in the magnetising windings, flux crosses the gap between the pole pieces, and the flux density in the gap is proportional to that in the magnet. An emf is induced in the revolving disc, this emf being proportional to the gap flux density. The emf is measured by a voltmeter V .

Thus, the voltmeter reading gives a measure of the flux density in the specimen. The value of H is obtained by the usual formula from the constants of the magnetising coils and from the current in these coils.

Some leakage exists between the two arms of the magnet, but with proper design of the apparatus its effect upon the results is small.

18'27. Magnetostriction. Magnetization of magnetic materials causes changes in dimensions both parallel to, and perpendicular to direction of magnetization. These changes are quite small but when the material is subjected to alternating magnetization as in power transformers, electrical machines and oscillators, varying changes in dimensions go on taking place. This is a source of noise and vibrations in these equipments.

A characteristic showing the magnetostriction of a given ferromagnetic material is the magnetostriction constant λ_s .

The magnetostriction constant may be defined as $\lambda_s = \frac{\Delta L}{L}$

where ΔL = extension (or contraction) of a specimen of length L in the direction of an applied field strength when the field strength H is raised from zero to a value causing technical saturation.

The magnetostriction constant may either be negative or positive. Since magnetostriction causes changes in dimensions, the magnetostriction constant may be measured by employing any transducer measuring displacement. These transducers are discussed in details in chapter 25.

It is interesting to note that since the field strength causes changes in dimensions, the value of field strength can be measured by measuring changes in dimensions of ferromagnetic materials on account of magnetostriction.

18'28. Methods used in Modern Instrumentation Systems. The methods and instruments described above do not convert magnetic flux to voltages acceptable to modern instrumentation systems. The following methods are usually adopted for modern systems.

1. Measurement of Flux Density using Hall Effect. The Hall Effect has been explained in pages 125 and 357.

Let us consider Fig. 18'31. Current is passed through leads 1 and 2 of the Hall strip. The output leads are at the same potential when there is no transverse magnetic field passing through the strip. When there is a magnetic flux through the strip, a voltage appears between output leads. This voltage is proportional to the current and the field strength.

$$\text{The output voltage } V_H = \frac{R_H I B}{t} \quad \dots(18'30)$$

where R_H = Hall co-efficient ; $\frac{V-m}{A-Wb\ m^{-2}}$,

I = current through the strip ; A,

B = flux density of field traverse to strip ; Wb/m^2 ,

and t = thickness of strip ; m.

Thus the voltage produced becomes a measure of flux density.

The Hall effect emf is very small in conductors and is difficult to measure, but in some semi-conductors, such as germanium, the emf is sufficiently large to be measured by a sensitive moving coil instrument.

The flux (strip) probes using Hall effect can be very small, and such probes are very useful in places where the space is limited. The size can be as small as $1.25 \times 1.25 \times 0.625$ mm. Instruments using such small crystals are manufactured in three ranges 0-0.5, 0-1.0 and 0-2.5 Wb/m^2 . These crystals should not be operated at a current density greater than 0.003 A/mm^2 .

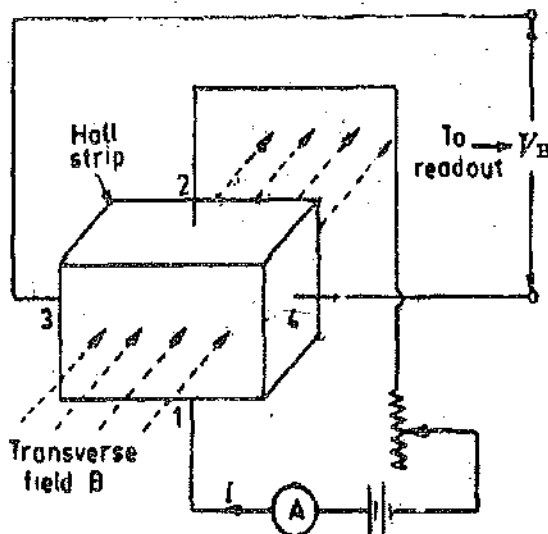

Fig. 18'31. Measurement of flux density using Hall Effect.

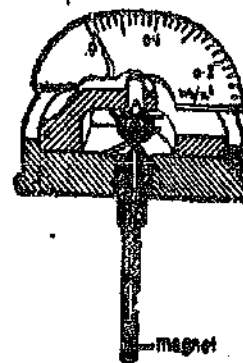

Fig. 18'32. Gauss meter.

2. Measurement of Flux Density with Gauss Meter. The General Electric Company makes a small and simple "Gauss meter". (This meter may safely be called a tesla meter now as the unit of

flux density prevalent these days is tesla *i.e.* Wb/m^2). It can be usefully employed in testing field strength in places such as the gap between the poles of a magnet. It consists of a tiny permanent magnet mounted at the end of a long, thin shaft (Fig. 18'32) which is supported and protected by a bronze tube. The assembly is used as a probe and has an outside diameter less than one-tenth of an inch. The head of the meter consists of a bearing, scale, pointer, and spring and has no electric or magnetic elements in it. The small probe magnet tends to align itself with any magnetic field around it. The person using the meter turns the head until the maximum indication is given on the scale; this gives the strength of the field. This meter is made possible by a new magnetic material called Silmanal, which has a very high coercive force (about ten times that of Alnico). This instrument has an accuracy of 1 per cent when special calibration methods are used, but commercial tolerances are of the order of 5 per cent.

3. Measurement of Flux Density using Bismuth Conductor. A bismuth conductor has the property of experiencing a change in electrical resistance if the conductor is placed in a transverse magnetic field. This effect has been used by several experimenters. One or two bismuth spirals are placed in some sort of thin mounting that can be inserted in the magnetic field, as for example, between armature and poles of a d.c. motor. The spiral can be made one arm of a Wheatstone bridge (or two spirals may be used in opposite arms as shown in Fig. 18'33). By calibration the resistance can be related to field strength. One difficulty is a rather low sensitivity to weak fields. Another, and more serious, trouble is the effect of temperature on the resistance of bismuth, so that large errors can result unless the temperature is carefully controlled or the effect compensated.

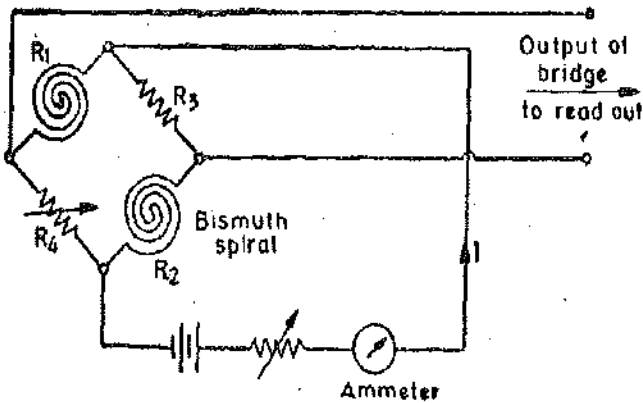

Fig. 18'33. Use of bismuth spirals in conjunction with a Wheatstone bridge for measurement of magnetic field strength.

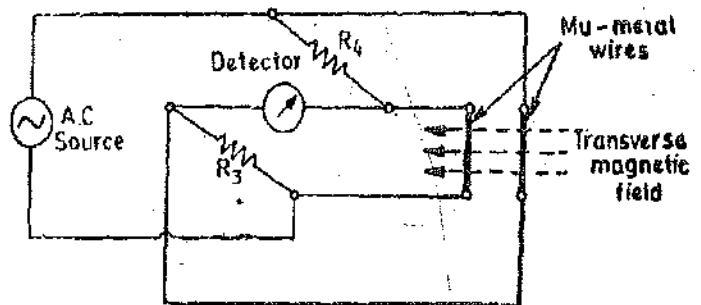

Fig. 18'34. Measurement of flux density, with Mu-metal wires.

4. Measurement of Flux Density with Mu-metal Wires. Mu-metal has the property of changing its impedance if placed in a transverse magnetic field. This property may be used to measure flux density with a conventional a.c. bridge.

This method is shown in Fig. 18'34 who two mu-metal wires are placed in the unknown magnetic field. The impedance of the wires is a function of the strength of magnetic field and is measured with an a.c. bridge.

This transducer produces an acceptable emf for the input to an instrumentation system and is capable of measuring field strength of the order of 10^{-7} Wb/m^2 .

Example 18'9. The iron loss in a sample is 300 W at 50 Hz with eddy current loss component 5 times as big as the hysteresis loss component. At what frequency will the iron loss be double if the flux density is kept the same ?

Solution. If the value of flux density is kept constant we can write

$$p_h = K_1 f \quad \text{and} \quad p_e = K_2 f^2$$

$$\text{Total iron loss/kg : } p_i = p_h + p_e = K_1 f + K_2 f^2$$

$$\text{Total iron loss at 50 Hz is : } 300 = K_1(50) + K_2(50)^2.$$

$$\text{But} \quad K_2(50)^2 = 5 \times K_1(50) \quad \therefore K_2 = 0.1 K_1.$$

Hence $300 = 0.1 K_1 (50)^2 + K_1 (50)$ or $K_1 = 1$

Suppose iron loss is doubled at frequency f_1 .

$$\therefore 2 \times 300 = K_1 (f_1) + K_2 (f_1)^2 \quad \text{or} \quad 600 = K_1 f_1 + 0.1 K_1 f_1^2 \quad \text{or} \quad f_1 = 72.6 \text{ Hz.}$$

Example 18.10. In loss tests on a sample of iron laminations the following results were recorded :

(i) 60 Hz, 250 V, total iron loss = 200 W. (ii) 40 Hz, 100 V, total iron loss = 40 W.

Calculate the eddy current and hysteresis loss for each test. The Steinmetz index is 1.6.

Solution. Eddy current loss $p_e = K_e B_m^2 f^2$. Hysteresis loss $p_h = K_h B_m^{1.6} f$

Total iron loss $p_t = p_h + p_e = K_e B_m^2 f^2 + K_h B_m^{1.6} f$

We have $E = 4.44 f (B_m A) N$

Now flux density is proportional to the applied voltage and inversely proportional to frequency and therefore in the above set of readings the value of flux density is not the same in the two cases.

Loss at 50 Hz and 250 V is : $200 = K_e B_{m1}^2 f_1^2 + K_h B_{m1}^{1.6} f_1$

Loss at 40 Hz and 100 volt is : $40 = K_e B_{m2}^2 f_2^2 + K_h B_{m2}^{1.6} f_2$

But $B_{m1} \propto 250$ and $B_{m2} \propto 100$

$$\text{or} \quad B_{m1} f_1 = 2.5 B_{m2} f_2 \quad \text{or} \quad B_{m1} = 2.5 \times \frac{40}{50} = 2 B_{m2}.$$

Hence $200 = K_e B_{m1}^2 (50)^2 + K_h (B_{m1})^{1.6} (50)$

$$40 = K_e \left(\frac{B_{m1}}{2} \right)^2 (40)^2 + K_h \left(\frac{B_{m1}}{2} \right)^{1.6} (50)$$

From above we have : $K_e (B_{m1})^2 = 0.049$ and $K_h (B_{m1})^{1.6} = 1.55$.

Hence, at 250 V and 50 Hz,

Eddy current loss = $K_e (B_{m1})^2 (50)^2 = 0.049 (50)^2 = 122.5 \text{ W}$.

Hysteresis loss = $K_h (B_{m1})^{1.6} (50) = 1.55 \times 50 = 77.5 \text{ W}$.

At 100 volt and 40 Hz:

Eddy current loss = $K_e \left(\frac{B_{m1}}{2} \right)^2 (40)^2 = \frac{0.049}{4} (40)^2 = 19.6 \text{ W}$

and Hysteresis loss = $K_h \left(\frac{B_{m1}}{2} \right)^{1.6} (40) = \frac{1.55}{2^{1.6}} (40) = 20.4 \text{ W}$.

Example 18.11. The following test results were obtained on a sample of steel stampings at 50 Hz.

Voltage <i>V</i>	4.9	69.3	91.8	100.5	110.5	118.0
Current <i>A</i>	0.2	0.3	0.46	0.52	0.64	0.77
Power <i>W</i>	9.5	16.8	27.5	32.5	39.0	44.8

Mean width of plates = 30 mm ; mean thickness = 0.489 mm ; number of plates = 51 ; total weight 11 kg ; number of magnetising turns in coil = 600.

Allowing a copper loss of 2 W in the magnetising winding, calculate iron loss in W/kg at a flux density of 1 Wb/m² and a frequency 50 Hz.

Solution. Area of core $A = \text{width} \times \text{thickness} = 30 \times 10^{-3} \times 51 \times 0.489 \times 10^{-3} = 0.748 \times 10^{-3} \text{ m}^2$.

Now induced voltage

$$E = 4.44f\Phi_m N = 4.44f B_m A N = 4.41 \times 50 \times 1 \times 0.748 \times 10^{-3} \times 600 = 99.7 \text{ V.}$$

A curve is plotted between the voltage and the power supplied. From this graph corresponding to a voltage of 99.7 V, power supplied is 30.3 W.

$$\therefore \text{Iron loss} = \text{power supplied} - \text{copper loss} = 30.3 - 2 = 28.3 \text{ W.}$$

$$\text{Loss per kg} = \frac{28.3}{11} = 2.57 \text{ W.}$$

Example 18.12. In an iron loss test on a 10 kg specimen of steel laminations, the peak flux density and the form factor were maintained constant and the following results were obtained :

Frequency, Hz	25	40	50	50	80
Total iron loss, W	18.5	36	50	66	104

Evaluate the eddy current and hysteresis loss per kg at 50 Hz.

Solution. If the flux density and form factor remain constant, we can write :

$$\text{Total iron loss } P_t = K_1 f + K_2 f^2 \quad \text{or} \quad \frac{P_t}{f} = K_1 + K_2 f$$

The value of P_t/f for various values of f are :

f	25	40	50	60	80
$\frac{P_t}{f}$	0.74	0.9	1.0	1.1	1.3

A graph is plotted between f and P_t/f as shown in Fig. 18.35.

From the graph

$$K_1 = 0.5 \text{ and } K_2 = 0.01.$$

$$\text{Eddy current loss at 50 Hz} = K_2 f^2 = 0.01(50)^2 = 25 \text{ W.}$$

$$\text{Eddy current loss per kg} = \frac{25}{10} = 2.5 \text{ W.}$$

$$\text{Hysteresis loss at 50 Hz} = K_1 f = 0.5 \times 50 = 25 \text{ W.}$$

$$\text{Hysteresis loss per kg} = 2.5 \text{ W.}$$

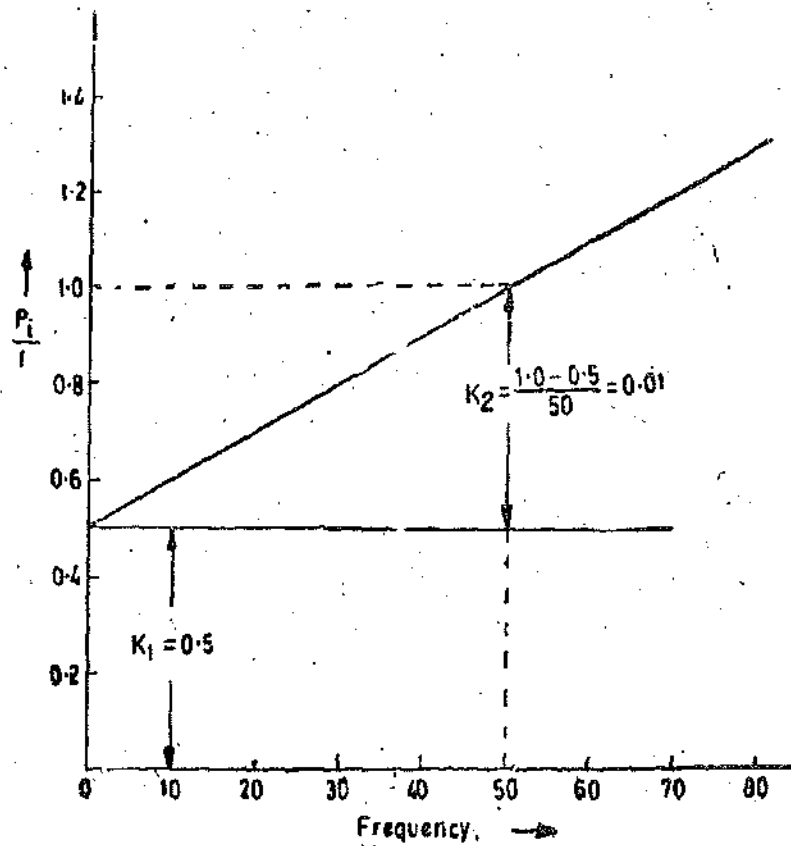

Fig. 18.35

Example 18.13. A test was conducted on a sample of sheet steel gave the following results at a maximum flux density of 1.0 Wb/m^2 with flux waveform purely sinusoidal.

Frequency, Hz	25	40	50	75
Iron loss P_i , W/kg	2.32	4.35	6.0	10.9

Determine (i) Hysteresis and eddy current loss in W/kg at 50 Hz and at 1.0 Wb/m^2 and also at (ii) a maximum flux density of 1.2 Wb/m^2 when the frequency is 60 Hz and the form factor of flux wave is 1.2. Assume Steinmetz index as 1.6.

Solution. For a constant value of flux density and form factor :

$$\text{total iron loss } P_i = K_1 f + K_2 f^2 \quad \text{or} \quad \frac{P_i}{f} = K_1 + K_2 f$$

The values of P_i/f for various values of f are :

f	25	40	50	75
P_i/f	0.093	0.109	0.12	0.145

A graph is drawn in Fig. 18.36 between P_i/f and f . From this graph, we get :
 $K_1 = 0.068$ and $K_2 = 0.00108$.

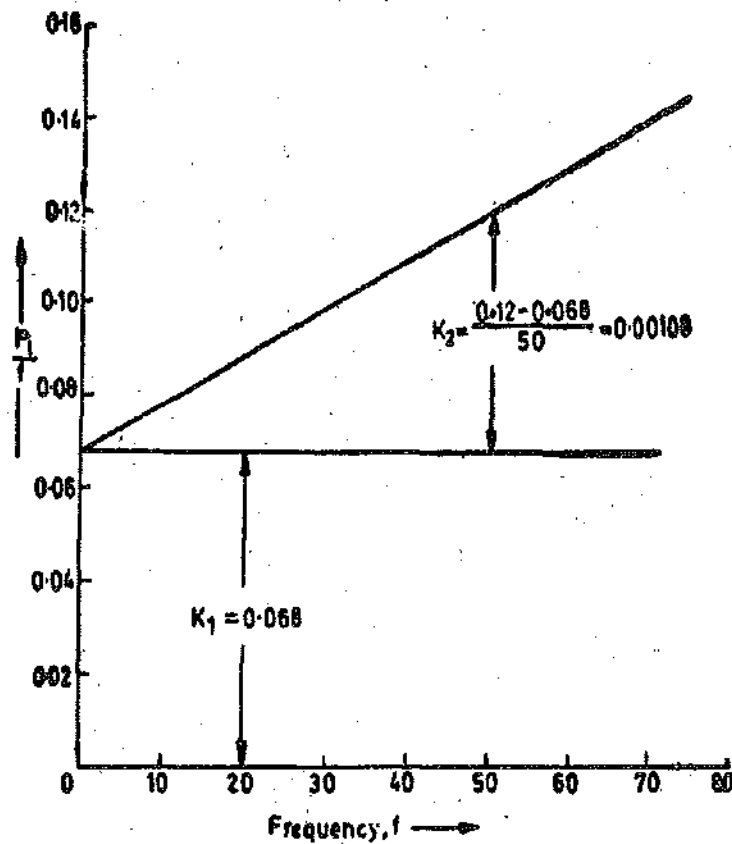

Fig. 18.36

\therefore Hysteresis loss at 50 Hz and $1.0 \text{ Wb/m}^2 = K_1 f = 0.068 \times 50 = 3.4 \text{ W/kg}$.

Eddy current loss at 50 Hz and $1.0 \text{ Wb/m}^2 = 0.00108 \times 50^2 = 2.7 \text{ W/kg}$.

Now hysteresis loss $\propto B_m^{1.6} f$

$$\therefore \text{Hysteresis loss at } 60 \text{ Hz and } 1.2 \text{ Wb/m}^2 = 3.4 \times \left(\frac{1.2}{1.0}\right)^{1.6} \times \left(\frac{60}{50}\right) = 5.47 \text{ Wb/m}^2.$$

Eddy current loss $\propto K_f^2 B_m^2 f^2$

Eddy current loss at 60 Hz, 1.2 Wb/m², and $K_f = 1.2$

$$= 2.7 \times \left(\frac{1.2}{1.11}\right)^2 \times \left(\frac{1.2}{1.0}\right)^2 \times \left(\frac{60}{50}\right)^2 = 6.5 \text{ W/kg.}$$

Example 18.14. The core fluxes of two identical transformers *A* and *B* are $10 \times 10^{-3} \sin \omega t$ weber and $(11 \sin \omega t - 1 \sin 3 \omega t) \times 10^{-3}$ weber respectively. Find for each transformer (a) form factor of flux waves, (b) mean value and form factor induced emf per turn, (c) Also find the hysteresis and eddy current losses of transformer *B* if they are 40 W and 15 W respectively for transformer *A*. $\omega = 314 \text{ rad/s}$.

Solution. The flux waves of two transformers are shown in Fig 18.37.

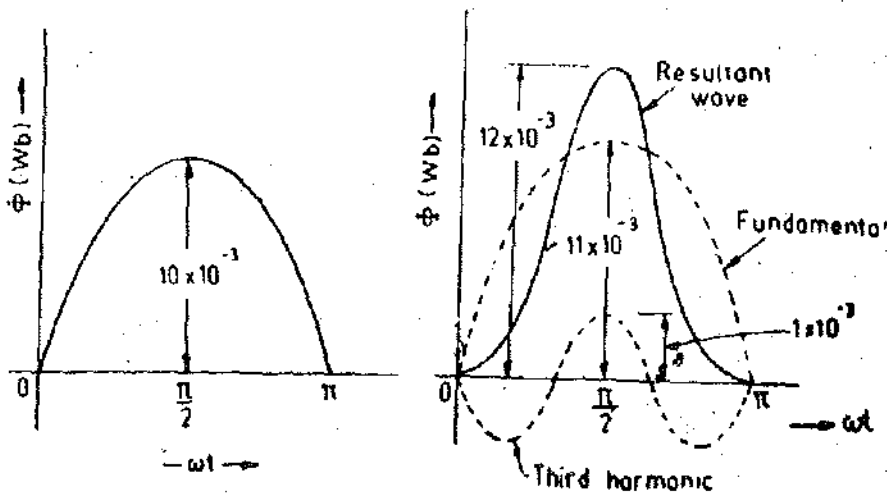

Fig.18.37

(a) **Transformer A.** The flux wave for transformer *A* is purely sinusoidal. The equation for flux wave is :

$$\Phi_A = 10 \times 10^{-3} \sin \omega t$$

\therefore Maximum value of flux of *A* is : $\Phi_{max A} = 10 \times 10^{-3} \text{ Wb}$.

Form factor for flux wave = 1.11.

Transformer B. The flux wave for transformer [Fig. 18.37 (b)] is a combination of a fundamental and a third harmonic. The maximum value occurs at $\pi/2$ as is clear from the diagram.

Maximum value of flux = $\Phi_{max B} = (11 + 1) \times 10^{-3} = 12 \times 10^{-3} \text{ Wb}$.

Average value of flux is : $\Phi_{av B} = \frac{1}{\pi} \int_0^{\pi} (11 \sin \omega t - 1 \sin 3 \omega t) d(\omega t) \times 10^{-3} = 6.8 \times 10^{-3} \text{ Wb}$.

R.M.S. value of flux : $\Phi_{r.m.s. B} = \sqrt{\frac{1}{\pi} \int_0^{\pi} (11 \sin \omega t - 1 \sin 3 \omega t)^2 d(\omega t) \times 10^{-3}} = 7.8 \times 10^{-3} \text{ Wb}$

\therefore Form factor of flux wave : $K_{fB} = \frac{\Phi_{r.m.s. B}}{\Phi_{av B}} = \frac{7.8 \times 10^{-3}}{6.8 \times 10^{-3}} = 1.15$

(b) **Transformer A.** Voltage induced $e_A = \frac{d\Phi_A}{dt} = 10 \times 10^{-3} \cos \omega t \times \omega = 3140 \times 10^{-3} \cos \omega t$

Average value of induced voltage $E_{av A} = \frac{2}{\pi} 3140 \times 10^{-3} \text{ V}$.

R.M.S. value of induced voltage $E_{rms A} = \frac{3140 \times 10^{-3}}{\sqrt{2}}$

∴ Form factor $K_f A = \frac{E_{rms A}}{E_{av A}} = \frac{2\sqrt{2}}{2} = 1.11$

Transformer B. Voltage induced $e_B = \frac{d\Phi_B}{dt} = \omega(11 \cos \omega t - 3 \cos 3\omega t) \times 10^{-3}$

Average voltage $E_{av B} = \frac{1}{\pi} \int_0^{\pi} \omega(11 \cos \omega t - 3 \cos 3\omega t) d\omega t \times 10^{-3} = 2 \text{ V.}$

R.M.S. voltage induced

$$E_{rms B} = \sqrt{\frac{1}{\pi} \int_0^{\pi} \omega^2 (11 \cos \omega t - 3 \cos 3\omega t)^2 d\omega t} \times 10^{-3} = 2.54 \text{ V.}$$

Form factor $= \frac{E_{rms B}}{E_{av B}} = \frac{2.54}{2} = 1.27.$

(c) Eddy current loss $P_e \propto K_f^2 B_m^2 f^2$ Also $B_m \propto \Phi_m$

$$\therefore \frac{P_{eB}}{P_{eA}} = \frac{(1.15)^2 \times (12 \times 10^{-3})^2 \times (50)^2}{(1.11)^2 \times (10 \times 10^{-3})^2 \times (50)^2} = 1.54.$$

∴ Eddy current loss in transformer B $P_{eB} = 1.54 \times 15 = 23.1 \text{ W/kg.}$

Hysteresis loss $W_h \propto f B_m^{1.6}$

$$\therefore \frac{P_{hB}}{P_{hA}} = \frac{50}{50} \times \left(\frac{12 \times 10^{-3}}{10 \times 10^{-3}} \right)^{1.6} = 1.34$$

∴ Hysteresis loss in transformer B $p_{hB} = 1.34 \times 40 = 53.6 \text{ W/kg.}$

Example 18.15. The resistance and inductance of a test coil L_1 , R_1 were determined at a frequency of $4000/2\pi$ Hz with a Maxwell's bridge shown in Fig. 16.4. The results were as follows:

(a) With air core the balance was obtained with

$$R_2 = 550 \Omega, R_3 = 18 \Omega, R_4 = 1250 \Omega, C_4 = 0.5 \mu F.$$

(b) With iron dust core, balance was obtained with

$$R_1 = 550 \Omega, R_3 = 18 \Omega, R_4 = 1125 \Omega, C_4 = 3.85 \mu F.$$

Determine the iron loss in the core at the test frequency. The voltage applied to the bridge is 50 V

Solution. From Eqs. 16.18 and 16.19 we have $R_1 = \frac{R_2 R_3}{R_4}$ and $L_1 = R_2 R_3 C_4$.

(a) With air core. When there is no iron core, resistance R_1 represents the resistance of the winding of the coil

$$\therefore \text{Resistance of winding of coil } R_w = \frac{550 \times 18}{1250} = 7.94 \Omega.$$

There is no use of calculating inductance with air core.

(b) **With iron core.** When the core is made iron, the resistance R_1 represents the resistance of winding plus resistance equivalent to iron loss.

$$\therefore \text{Effective resistance of coil} = \frac{550 \times 18}{1125} = 8.81 \Omega.$$

Hence resistance equivalent to iron loss in core $= 8.81 - 7.94 = 0.87 \Omega$.

Inductance of iron cored coil $L_1 = 550 \times 18 \times 3.85 \times 10^{-6} = 38.2 \times 10^{-3} \text{ H}$.

$$\text{Reactance of coil} \quad X_1 = 2\pi \times \frac{4000}{2\pi} \times 38.2 \times 10^{-3} = 152.8 \Omega$$

At balance current through the coil

$$I_1 = \frac{V}{\sqrt{(R_1 + R_2)^2 + X_1^2}} = \frac{50}{\sqrt{(8.81 + 18)^2 + (152.8)^2}} = 0.322 \text{ A}.$$

$$\text{Iron loss} \quad = I_1^2(8.81 - 7.94) = (0.322)^2 \times 0.87 = 0.09 \text{ W}.$$

Example 18.16. An iron cored coil and a standard 2Ω resistor are connected in series and the potential difference is measured across each on an a.c. potentiometer of Co-ordinate type. The readings are $3.6 + j1.2 \text{ V}$ for the coil and $4.8 - j2 \text{ V}$ for the resistor. Calculate the magnetising component and loss component of current through the coil.

$$\text{Solution. Current through the coil } I = \frac{4.8 - j2.0}{2} = 2.4 - j1.0 = 2.6 / -22^\circ 36' \text{ A}.$$

$$\text{Voltage across the coil} \quad V = 3.6 + j1.2 = 4.07 / 18^\circ 18' \text{ V}$$

$$\text{Angle between } V \text{ and } I \text{ is } \phi = 18^\circ 18' + 22^\circ 36' = 40^\circ 54'$$

$$\text{Loss component of current } I_c = I \cos \phi = 2.6 \cos 40^\circ 54' = 1.96 \text{ A}.$$

$$\text{Magnetising component of current } I_m = I \sin \phi = 2.6 \sin 40^\circ 54' = 1.72 \text{ A}.$$

Example 18.17. A germanium crystal having dimensions of $5 \times 5 \times 2 \text{ mm}$ is used for measurement of flux density. The Hall co-efficient is $-0.8 \frac{\text{V-m}}{\text{A-Wb m}^{-2}}$. Find the field strength if the voltage developed is 0.36 V the current density $3 \times 10^{-3} \text{ A/mm}^2$.

Solution. Current $I = 3 \times 10^{-3} \times 5 \times 5 = 75 \times 10^{-3} \text{ A}$. From Eqn. 18.30, the flux density is:

$$B = \frac{E \times I}{R_h \times I} = \frac{0.36 \times 2 \times 10^{-3}}{0.8 \times 75 \times 10^{-3}} = 0.012 \text{ Wb/m}^2.$$

UNSOLVED PROBLEMS

1. A coil of 1000 turns is wound uniformly over an annular ring former of mean diameter 1 metre. A second shorter coil is mounted inside the first, co-axially with it. The coil has 50 turns and a mean diameter of 25 mm. A ballistic galvanometer is connected to this second coil. The total resistance of the secondary circuit is 2500Ω . When a current of 5 A through the first coil is reversed, the galvanometer is deflected through 100 divisions. Neglecting damping, calculate the constant of the galvanometer. [Ans. 1.24×10^{-9} coulomb/division]

2. A ring having a mean diameter of 0.3 m and a cross-sectional area 400 mm^2 has a primary winding of 80 turns wound uniformly. The secondary winding of 30 turns is connected to a flux meter having a constant of 0.12×10^{-3} weber turn per division. A deflection of 46 divisions is observed when a current of 2 A is reversed in the primary. Calculate the relative permeability of iron. [Ans. 1080]

3. A ballistic galvanometer is used for determining the leakage co-efficient of a d.c. machine. The galvanometer has a constant of $0.2 \mu\text{C}$ per scale division and a circuit resistance of 8000Ω . The galvanometer is first connected

to a search coil of 3 turns wound on field coil of a machine and then to a search coil of 6 turns placed on the armature. With normal field current broken, the galvanometer readings in the two cases are 150 and 240 divisions respectively. Calculate the leakage co-efficient of the machine. [Ans. 1.25]

4. A ring specimen of mild steel has a cross sectional area of 600 mm^2 and a mean periphery of 0.25 m . It is uniformly wound with two coils, *A* and *B* having 80 and 300 turns respectively. Coil *B* is connected to a ballistic galvanometer having a constant of 12×10^{-3} coulomb per division; the total resistance of this circuit is $0.2 \text{ M}\Omega$. When a current of 2.2 A through coil *A* is reversed the galvanometer gives a maximum deflection of 180 divisions. Neglecting the damping of the galvanometer calculate (a) flux density in the iron (b). If radial saw cut of 0.5 mm wide, is made in the ring, find the magnetising current in coil *A* to give the same flux density. [Ans. (a) 1.2 Wb/m^2 (b) 8.17 A]

5. The area of hysteresis loop for a certain magnetic material is 5000 mm^2 and the scales of the graph on which it is drawn are :

H axis, $1 \text{ mm} = 25 \text{ A/m}$; *B* axis, $1 \text{ mm} = 15 \text{ m Wb/m}^2$. Calculate the hysteresis loss per kg. The frequency is 50 Hz and the density of the material is 8500 kg/m^3 . [Ans. 11 W]

6. A transformer is operated on 1000 V , 50 Hz and gives a total loss 1000 W , of which 700 W is due to hysteresis. If the transformer were to operate at 2000 V and 100 Hz , what would be losses due to hysteresis and eddy currents? Steinmetz index is 1.6. [Ans. Hysteresis 1400 W ; Eddy currents $= 1200 \text{ W}$]

7. Calculate the percentage change in the hysteresis and eddy current losses of a choke coil if other factors remain constant (i) The form factor of applied voltage decreases by 20% (ii) The frequency of the applied voltage increases by 20% . Neglect resistance of choke coil.

[Ans. (i) hysteresis loss : no change ; eddy current loss 36% decrease

(ii) hysteresis loss : 20% increase ; eddy current loss 44% increase]

8. A laminated iron ring specimen is magnetically tested and has a coil of 250 turns wound round the ring. The relationship between current and magnetic flux is :

Current <i>A</i>	Flux, <i>mWb</i>	Current <i>A</i>	Flux, <i>mWb</i>
0	-0.44	1.75	0.545
0.25	-0.37	2.0	0.56
0.5	-0.2	1.5	0.55
0.75	0.25	1.0	0.535
1.0	0.37	0.5	0.51
1.25	0.47	0	0.44
1.5	0.52		

Calculate the hysteresis loss per cycle.

[Ans. 0.318 J/cycle]

9. The following test results refer to a sample of steel :

1. At a constant flux density

Frequency, Hz	20	32	40	48	64
Loss, W	14.8	28.5	40	53	84

2. At a constant frequency of 40 Hz

Peak flux density Wb/m ²	0.25	0.5	0.75	1.0	1.25	1.5
Loss W	3	10.8	22.8	40	61	85

The test were carried out on 10 kg of steel. Determine (a) eddy current loss/kg at $B_{max}=1$ Wb/m² and frequency 40 Hz. Also find (b) the index k in the expression ηB_m^k for the hysteresis loss per cycle.

[Ans. (a) 2.08 W/kg; $k=1.74$]

10. A ring is made of thin annular laminations of steel weighs 1.5 kg and carries a uniform toroidal winding. The winding is connected to a 50 Hz supply and the total power loss (due to hysteresis and eddy currents) is 0.6 W at a maximum flux density of 0.5 Wb/m². Estimate power loss to be expected when the maximum flux density is increased to 1.0 Wb/m² and frequency is decreased to 20 Hz. Assume the hysteresis loss is given by the formula,

$$\eta f B_m^k \text{ W/kg}$$

where f =frequency; B_m =maximum flux density Wb/m²; $\eta=2.3$ and $k=1.7$.

[Ans. 0.754 W]

11. The primary and secondary windings of a toroidal transformer have 330 and 25 turns respectively. A 1 Ω resistor is connected in series with the primary across a 50 Hz supply. The following readings were obtained using an a-c potentiometer.

Voltage across 1 Ω resistor: $(0.0734 + j 0.0094)$ V

Voltage across primary terminals: $(0.1151 + j 0.1124)$ V

Voltage across secondary terminals: $(-0.0017 - j 0.0074)$ V.

If the mean diameter of coil is 10 cm and the cross-section is 2.5×0.3 cm, calculate: (i) iron loss, (ii) I^2R loss in the primary winding, and (iii) relative permeability of core.

State the assumptions made.

[Ans. (i) 2.57 mW; (ii) 6.63 mW; (iii) 188.3]

12. The cores of two identical transformers carry alternating fluxes whose instantaneous values are $10 \times 10^{-3} (\sin 314 t)$ and $12 \times 10^{-3} (1.1 \sin 6.8 t + 0.1 \sin 1880 t)$ weber respectively. Find the ratio of eddy current loss of transformers. Find also the ratio of hysteresis loss. [Ans. Eddy current loss ratio=5.47, Hysteresis loss ratio=2.6]

Illumination

19.1. Physics of Light. The exact nature of light has been a subject of conjecture by philosophers for many centuries. In the nineteenth century Maxwell, Hertz and others showed that electromagnetic radiation had many of the same properties as light. There are some aspects which the electromagnetic theory is not able to explain. Planck and Einstein reasoned that light could be radiated and absorbed discontinuously in discrete bundles of energy called "quanta" or "photons". The term "quanta" leads us to quantum theory of light.

Both the quantum and the electromagnetic theories of light are today needed to explain the phenomenon of energy transfer by light, but we will mainly concentrate on "Electromagnetic theory of light".

19.2. Light. Light is a sensation, while light radiation is a physical phenomenon. Light is energy propagated with a high velocity in space, and whose presence can be detected only by virtue of its effects. The most important effect of radiation in this form from our point of view lies in its reactions upon the visual apparatus, and the reactions which enable us to see.

Radiation, a physical phenomenon is the cause, and light which is only a sensation, is the effect, although the cause and effect go together, the two should not be confused.

19.3. Electromagnetic Spectrum. Newton discovered that when white light, such as that given by the sun, is passed through a glass prism, a band of light is obtained having colours in the following sequence : red, orange, yellow, green, blue and violet.

Light is in the form of electromagnetic radiation having a velocity of 3×10^8 m/s and various colours have different frequencies ranging from about 4×10^{14} Hz for the extreme visible red end of the spectrum to about 7.5×10^{14} Hz for the extreme visible violet end.

The wavelength for any radiation is given by wave-length :

$$\lambda = \frac{c}{f} \quad \dots(19.1)$$

where c = speed of radiation in free space m/s and f = frequency of radiation, Hz.

Thus from Eqn. 19.1, wave-length of extreme end of red spectrum

$$= \frac{3 \times 10^8}{4 \times 10^{14}} = 0.75 \times 10^{-6} \text{ m} = 0.75 \mu\text{m}$$

and wave-length of extreme end of visible end of violet spectrum

$$= \frac{3 \times 10^8}{7.5 \times 10^{14}} = 0.4 \times 10^{-6} \text{ m} = 0.4 \mu\text{m}.$$

Electromagnetic radiations that are immediately below the red end of spectrum are called "infrared" while radiations that immediately above the violet end of the spectrum are termed as "ultraviolet."

In the case of light emitted by incandescent solid bodies, the spectrum is continuous, but the relative intensity of different colours depends upon the temperature of the radiating body—the higher the temperature, the more pronounced is the violet end of the spectrum compared with the red end. When light is obtained from a gaseous discharge, the spectrum is not continuous but discon-

tinuous, *i.e.*, it consists of not one single colour line but many colour lines of the same colour or of different colours. Thus in the case of the sodium lamp, the spectrum consists mainly of two yellow lines very close together with wavelengths of 0.5890 and $0.5896 \mu\text{m}$. These two wavelengths are so close to each other, that the light from a sodium lamp is said to be "monochromatic", *i.e.*, light having only one wavelength.

19.4. International Luminosity Curve. In the electromagnetic spectrum the range of visible wavelength is very small. Light radiation may be considered as a vibration, propagated at a high velocity of a wavelength between $0.4 \mu\text{m}$ to $0.75 \mu\text{m}$. The human eye responds to wavelengths of approximately $0.38 \mu\text{m}$ to $0.75 \mu\text{m}$. Radiation of any wavelength outside these limits produces no sensation of light in the visual apparatus of human beings. The familiar colours of spectrum vary from violet beginning from violet at about $0.4 \mu\text{m}$ wavelength and ending at red at about $0.75 \mu\text{m}$ wavelength. The average eye is sensitive to the intermediate wavelengths in the degree represented by the "luminous efficiency curve".

Light is the medium of sight and is defined as radiant energy evaluated according to its capacity for producing visual sensation.

A light source having the same rate of energy emission at each wavelength is called an equal energy source and is represented by a vertical line in the spectrum of Fig. 19.1. This diagram shows how the sensitivity or the brightness of sensation of an average human eye varies at different wavelengths for ordinary levels of illumination, the power radiated being constant for different wavelengths. This curve represents the relative luminous efficacy of different wavelengths as compared to an equal energy source. This curve is known as "International luminosity curve". As far relative luminous efficacy of radiation is concerned we define it as the ratio of the visual effect of light of a given wavelength to that of an equal energy source. It is clear from the curve that a wavelength of $0.555 \mu\text{m}$ in the green portion of spectrum has a relative luminous efficacy of nearly unity and thus the human eye is most sensitive to light having a wavelength of $0.555 \mu\text{m}$.

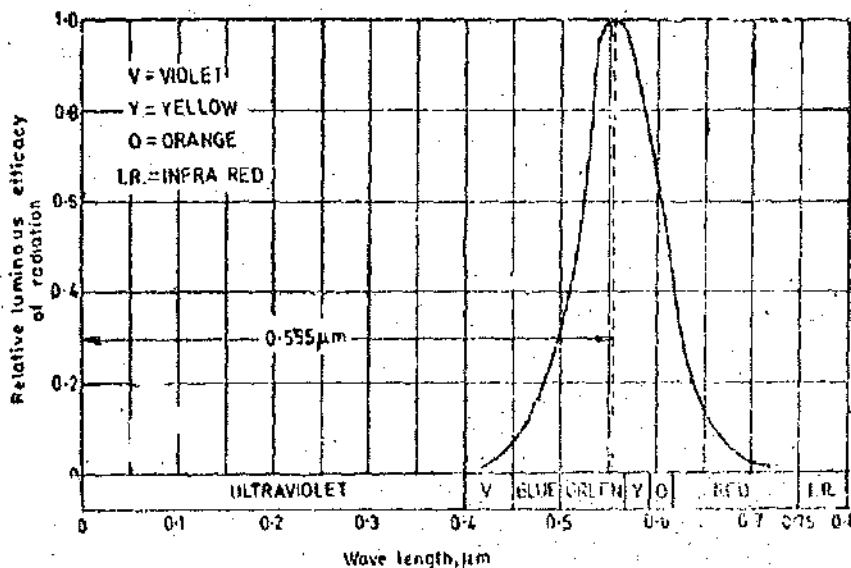

Fig. 19.1. International luminosity curve.

The photometric evaluation of light was originally done by trained observers using visual means for matching the unknown with a calibrated and controlled source. The human eye is very proficient in detecting differences in colour and brightness but cannot make absolute measurements. This is unfortunate and is due to the fact that the colour sensitivity of the light varies from one individual to another and hence when matching lights of different colours two observers are likely to obtain different readings. To eliminate the visual observational differences in photometric measurements, the characteristics of average human eye were determined statistically and agreed by the International Commission of Illumination (CIE) and thus an International Luminosity Curve as shown in Fig. 19.1 was introduced. The relative luminous efficacy values for different wavelengths standardized are given in Table 19.1.

TABLE 19.1
Relative Efficacy of Radiation of Different Wavelengths

Wavelength, μm	Relative efficacy	Wavelength, μm	Relative efficacy
0.38	0.00004	0.57	0.52
0.39	0.00012	0.58	0.870
0.40	0.0004	0.59	0.757
0.41	0.0012	0.60	0.631
0.42	0.004	0.61	0.503
0.43	0.0116	0.62	0.381
0.44	0.023	0.63	0.265
0.45	0.038	0.64	0.175
0.46	0.06	0.65	0.107
0.47	0.091	0.66	0.061
0.48	0.139	0.67	0.032
0.49	0.208	0.68	0.017
0.50	0.321	0.69	0.0082
0.51	0.503	0.70	0.0041
0.52	0.710	0.71	0.0.21
0.53	0.80	0.72	0.00105
0.54	0.954	0.73	0.00052
0.55	0.995	0.74	0.00025
0.56	0.995	0.75	0.00012
		0.76	0.00006

The most common and useful source of light is sun, and it radiates different powers at different wavelengths. It is found that it radiates maximum power at a wavelength of $0.5 \mu\text{m}$, which is approximately the wavelength at which the human eye is most sensitive.

19.4. Photon. As stated earlier, that EM radiation at a particular frequency can propagate in only discrete quantities of energy. The energy is emitted as large number of units or quanta. These quanta are called photons. The actual energy of one photon is :

$$W = hf = \frac{hc}{\lambda} \quad \dots(19.2)$$

where W = photon energy ; J, and h = Planck's constant = 6.63×10^{-34} J-s.

The energy of one photon is very small compared to electric energy normally encountered. Fig. 19.2 shows the energy carried by a single photon at various wavelengths. This energy is expressed in electron volt (eV). The relationship between electron volt and joule is :

$$1 \text{ eV} = 1.602 \times 10^{-19} \text{ J}, \quad \dots(19.3)$$

It should be remembered that :

Charge of electron $e = -1.6 \times 10^{-19} \text{ C}$
 Mass of electron $m = 9.11 \times 10^{-31} \text{ kg}$
 $e/m \text{ ratio} = 0.176 \times 10^{12}$

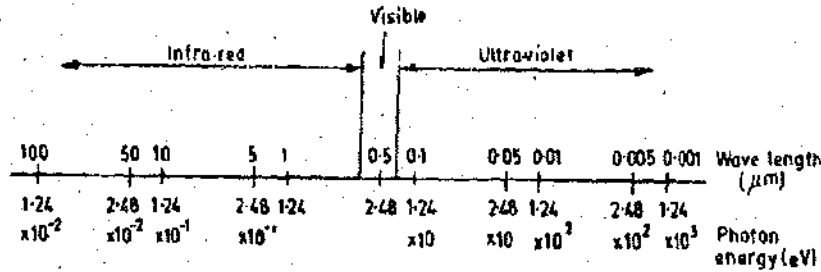

Fig. 19.2. Energy of one photon in eV at various wavelengths.

19.5. Energy and Power. When dealing with optical transducers and sources, it is necessary to consider the discrete nature of radiation. Instead, a more meaningful understanding can be had from the macroscopic properties which are a result of the collective behaviour of a large number of photons moving together. This leads us to classical mechanics wherein the general energy principles involve a description of the net energy content of the radiation. The energy is then described in terms of joule.

Since EM radiation is energy in motion, it should be described in terms of joule per second (J/s) or watt (W) which are units of power.

19.6. Intensity. The description of EM radiation in terms of power is incomplete unless its spatial distribution in a direction transverse to the direction of propagation is specified. The Intensity is defined as the power per unit area perpendicular to the direction of EM radiation.

The intensity is : $I = P/A$

...(19.4)

where $I = \text{intensity ; W/m}^2$, $P = \text{power ; W}$
 and $A = \text{area of cross-section of beam ; m}^2$.

19.7. Effect of Temperature on Radiation. Fig. 19.3 shows the relative values of the power radiated from an incandescent filament lamp at different temperatures. It is evident from this diagram that the lower the temperature, the lower is amount of energy radiated in the visible range. Thus incandescent lamps should be operated at highest possible temperatures.

Example 19.1. The frequency of a given electromagnetic radiation is $5 \times 10^{14} \text{ Hz}$. Find the wavelength. Does this radiation fall within the visible spectrum ?

Solution. Wave-length $\lambda = \frac{V}{f} = \frac{3 \times 10^8}{5 \times 10^{14}}$
 $= 0.6 \times 10^{-6} \text{ m}$
 $= 0.6 \mu\text{m}.$

Now the range of wavelengths of visible spectrum is from 0.38 to $0.76 \mu\text{m}$ and hence this radiation falls within the visible spectrum.

Example 19.2. The relative efficacy of radiation of a wavelength of $0.61 \mu\text{m}$ is approximately 0.5 . The international luminosity curve indicates relative efficacy of a wavelength of $0.555 \mu\text{m}$ as unity. Radiation

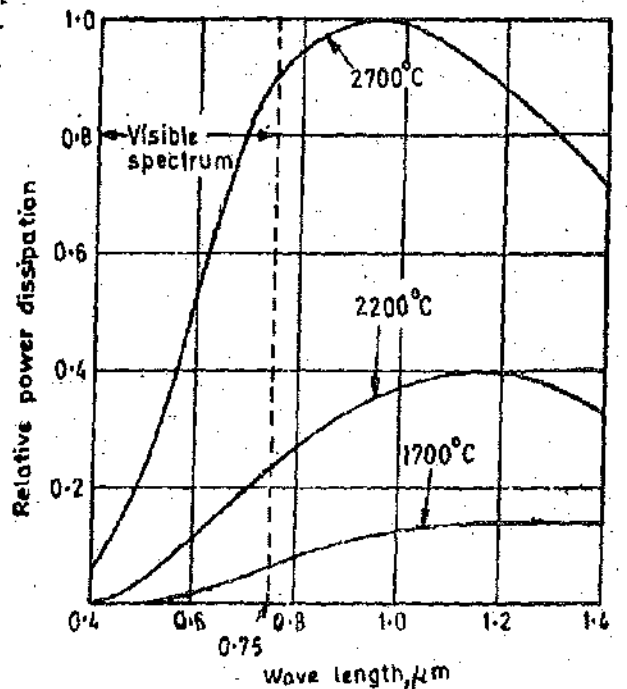

Fig. 19.3. Special power distribution curves at different temperatures for incandescent filament.

equivalent to 10 W is produced by a wavelength of $0.555 \mu\text{m}$. Find out the radiation (in W) at a wavelength of $0.61 \mu\text{m}$ which will produce the same sensation in the human eye.

Solution. Relative efficacy of radiation at a wavelength of $0.61 \mu\text{m}$ is 0.5 times that of radiation at a wavelength of $0.555 \mu\text{m}$.

\therefore Power required at a wavelength of $0.61 \mu\text{m}$

$$= \frac{\text{power required at a wavelength of } 0.555 \mu\text{m}}{\text{relative efficacy}} = \frac{10}{0.5} = 20 \text{ W.}$$

19.8. Full Radiator or Black Body. A full radiator or black body absorbs completely all incident radiation whatever the wavelength or direction of incidence. Such a body is also a good emitter of radiation. Also when raised in temperature its radiant energy is greater than any other body of the same size and working at the same temperature and hence the name "full radiator". It is actually quite easy to obtain a full radiator (or true black body) since a small hole in a hollow container is a black body, and when the container is heated the whole acts as full radiator.

19.9. Primary Standard. The primary standard originally used in photometry was a wax candle but it was unreliable. This standard was subsequently abandoned for many other standards which also did not produce reliable and satisfactory results.

In 1948, it was decided to base the unit of luminous intensity upon the luminance (or objective brightness) of a small aperture due to light emitted from a radiator maintained at the temperature of solidification of platinum namely 2042°K . This primary standard is a full radiator at the temperature of solidification of platinum. The construction of this primary standard is shown in Fig. 19.4.

The radiator consists of a cylinder of fused thorium oxide about 45 mm long, with an internal diameter of about 2.5 mm. The bottom of the tube is packed with powdered fused thorium oxide. The cylinder is supported vertically in pure platinum contained in fused thorium oxide crucible. The latter has a lid with a small hole in the centre, about 1.5 mm in diameter, and is almost embedded in powdered fused thorium oxide in a larger refractory container having a funnel shaped opening.

The platinum is first melted by eddy currents induced in it by a high frequency coil surrounding the outer container. The coil carries alternating current at a frequency of 1.6 MHz. The platinum is allowed to cool very slowly. During the period platinum is changing from liquid to solid state, the temperature remains constant sufficiently long for measurements to be made of luminous intensity of the light passing from the aperture of known diameter. The luminance of this primary standard is found to be 589,000 international candle/ m^2 , the international candle being used prior to 1948.

In 1948 it was decided to adopt 600,000 units/ m^2 as the luminance of primary standard. The new unit of luminous intensity was termed as "Candela". Candela is defined as the luminous intensity, in the perpendicular direction, of a surface of $1/600,000$ square metre of black body (or full radiator) at the temperature of freezing of platinum under standard atmospheric pressure.

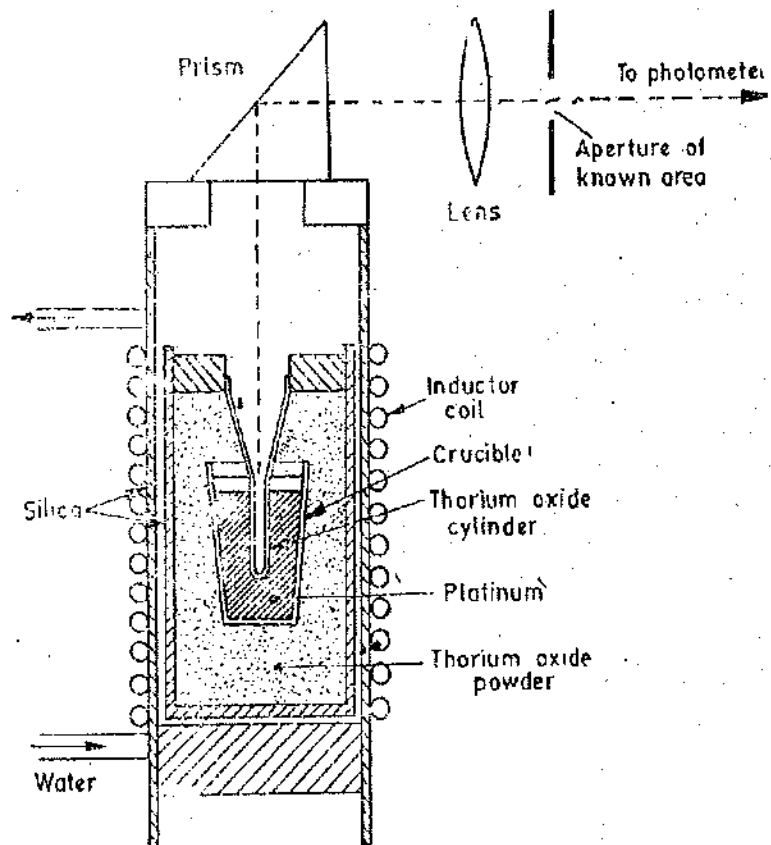

Fig. 19.4. Primary standard of luminous intensity.

19'10. Calibration of Standard Lamps with Primary Standard. The primary standard described above is used to calibrate standard lamps, using a photometer head. In order to facilitate the comparison the source is provided with a prism and lens as shown in Fig. 19'4. The lens is used to produce an enlarged image of the aperture provided in the standard source. This image illuminates one of the surfaces of the photometer head. The "transmission factor" of the prism and lens has to accurately measured.

The transmission factor of an object is defined as :

$$\text{Transmission factor} = \frac{\text{luminous flux transmitted by the object}}{\text{luminous flux incident upon the object}}$$

Platinum solidifies at 2042 K and its colour is different from that of most of the practical sources. The colour temperature of a source is the temperature of a full radiator which matches the source in colour and emits radiation of substantially the same spectral distribution within the visible region. A tungsten filament lamp is about 2,360 K and gas-filled lamps are about 2,800 K to 3,000 K. The colour difference encountered in comparing sources of different colour temperature is overcome by the use of a special blue filter which increases the colour temperature of the source. The transmission factor of these filters is usually about 50 per cent.

19'11. Secondary Standards and Substandards. It is clear that primary standard is unsuitable for day-to-day working and it is therefore used to calibrate working substandards in the following manner : the primary standard is used to determine the luminous intensity of specially-made, tungsten filament lamps which are under-run to match the primary standard in colour. These lamps are then compared with other lamps which operate at a colour temperature of 2,360 K, the colour difference being overcome by means of the special blue glass filter. Lamps of this second group constitute the secondary working substandards of luminous intensity. Another group of tungsten filament lamps form the substandards of luminous flux. Their luminous intensities, in a large number of directions, are measured by comparison with the substandards of luminous intensity and the luminous flux for each lamp is deduced. Substandards of luminous flux at 2,800 K are established by comparison with those operating at 2,360 K using the blue glass filter again.

19'12. Laboratory Standards. Standards for use in general laboratory measurements must be conveniently portable and robust. Incandescent lamps are now used for this purpose, their luminous intensity being first of all obtained by comparison with a primary standard, or a calibrated standard and thereafter checked from time to time against such a standard.

The principal requirement of such substandard lamps is that their intensity shall not vary appreciably with time, and that the light which reaches the photometer from the lamp shall be of a uniform character.

A special construction is adopted for substandards which are to be used in precise work. The filament is of tungsten, and is mounted in a single plane, this plane being at right angles to the axis of the photometer bench when measurements are being made. This is necessary in order to fix, definitely, the direction in which the intensity of the lamp is that measured when the lamp was standardized. For the same reason these lamps are permanently fixed in a special holder which can be attached to the photometer bench, and which ensures that the direction in which the light is radiated by the lamp to the photometer "head", or measuring device, is always the same as when the lamp was standardized. This precaution is necessary, since the intensity of the lamp will not be the same in all directions, due to the effects of the supports for the filament, to slight differences in thickness of the glass bulb, and to other causes. The leads to the terminals of the lamp are also permanently connected to avoid unsteadiness of contact. Further, in order to ensure constancy of intensity, the joints between filament and leading in wires are welded, the bulb is made specially large in order to reduce the density of any blackening deposit upon the glass, and after manufacture the lamps are "aged" before standardization by being run for 100 hours or more. In use, these lamps must be run at a specified voltage, which must not be exceeded by even a small percentage, if the intensity is to remain constant.

Substandards of luminous flux differ in construction from intensity standards. The glass envelope is spherical, interrupted only by the support, and the filament approximates to a full circle. Normally the filament forms an octagonal figure with the connections at two opposing corners so that there are two parallel paths for the current. This eliminates variations in the light distribution which would be caused by a discontinuity in the filament.

In all lamps used as standards or substandards the filament supports are frosted to prevent reflections.

In order that substandard lamps shall not be used any more than is absolutely necessary, comparison lamps are often used for laboratory purposes, these lamps being such that their luminous intensity remains reasonably constant. Such lamps may be checked at frequent intervals against the substandard.

19'13. Terms, Definitions and Symbols. In the last few pages we have used certain terms without really explaining their meaning and significance. In this section we will state the terms already used and also quite a few new ones which are connected with the topic of illumination.

1. Luminous intensity. The luminous intensity of a source is defined as the light radiating capacity of the source in a given direction. Its unit is candela and in short "cd". The symbol for luminous intensity is I .

2. Point source. A point source of light is a source which, for photometric purposes, can be considered with sufficient accuracy as concentrated at a point.

3. Uniform point source. A uniform point source is a point source emitting light in all directions.

4. Lumen. If a uniform point source of 1 candela is placed at the centre of a perfectly transparent sphere of, say, 1 m radius (Fig. 19'5), then the solid angle subtended at the centre by 1 m² of area on the surface of the sphere is called a unit solid angle or steradian. The light passing through a unit solid angle or 1 m² of the surface area for a sphere of 1m radius is called a lumen. Lumen has a symbol of lm. The symbol used for solid angle is Ω .

5. Luminous flux. The luminous flux is defined as the light energy radiated per second from a luminous body. Therefore, luminous flux is in the form of power. Its symbol is F or Φ .

In fact the luminous flux from a source of light is the radiant power evaluated according to its ability to produce visual sensation on the basis of the relative luminous efficacy. The unit of luminous flux is lumen (lm).

Thus unit flux is the light energy radiated per second in unit solid angle by a uniform point source.

Generalizing the luminous flux emitted by a point source is : $dF = I \cdot d\Omega$ lumen

where I = intensity of the source ; $d\Omega$ = solid angle, steradian.

Or we can write : Intensity $I = \frac{dF}{d\Omega}$ candela. ... (19'5)

The luminous intensity of a point source can thus be defined as luminous flux per unit solid angle.

6. Irradiation. It must be remembered that the "light power" discussed here must be of suitable wavelength. In order to obtain a more general criterion, we describe the response of the device (Irradiation) in terms of watts per unit area. However, we must make a clear distinction between Total Irradiation, the total energy incident on the surface, and the Illuminance *i.e.* the energy which falls within the visible spectrum.

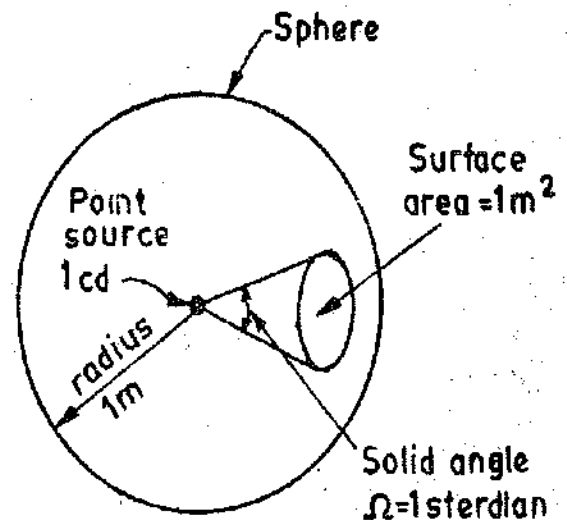

Fig. 19'5. Relationship between candela and lumen.

The irradiation is expressed in terms of W/m^2 .

1 watt = 680 lumen at a wavelength of $0.555 \mu m$.

$$\therefore \text{Irradiation } H = \frac{\text{light power}}{\text{area}} \text{ W/m}^2 \quad \dots(19.6)$$

7. Mean Spherical Luminous Intensity (M.S.L.I). This is defined, for a source of light, as the mean of luminous intensities in all directions from the source of light which radiates the same total flux uniformly in all directions.

8. Mean Horizontal Luminous Intensity (M.H.L.I). This is defined, for a source of light, as the average value of luminous intensities in all directions in a horizontal plane passing through the source of light.

9. Mean Hemispherical Luminous Intensity (M.H.L.I). This is defined as the average value of luminous intensity in all directions within a hemisphere, either above or below the horizontal plane through the centre of the source.

10. Luminance. It is defined, for a given point and in a given direction, as "the quotient of the luminous intensity in the given direction of an infinitesimal element of the surface containing the point under consideration, by the orthogonally projected area of the element on a plane perpendicular to the given direction". Its unit is nit or cd/m^2 . Its symbol is L .

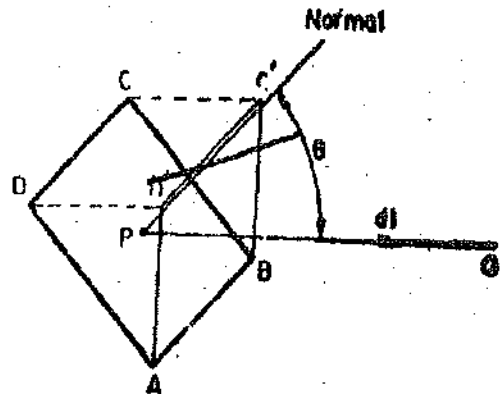

Fig. 19.6

Let $ABCD$ be a small area dA for which luminous intensity in the direction PQ inclined to the normal is dI , as shown in Fig. 19.6. The orthogonally projected area of the element $ABCD$ of area dA is $dA \cos \theta$. Therefore luminance L of the element when viewed in the direction QP

$$L = \frac{1}{\cos \theta} \cdot \frac{dI}{dA} \quad \dots(19.7)$$

The unit of luminance is cd/m^2 or nit.

11. Illuminance (Illumination). The illuminance (illumination) of a surface is measured in terms of flux per unit area. Its unit is lux (lx) which is one lumen per square metre. The symbol of illuminance is (E) .

Suppose a flux dF falls on an area dA ,

$$\therefore \text{Illuminance } E = \frac{dF}{dA} \text{ lux} \quad \dots(19.8)$$

12. Luminosity. Luminosity is defined as the attribute of visual perception in accordance with which an area appears to emit more or less light.

19.14. Laws of Illuminance (Illumination)

1. Inverse Square Law. The illuminance of a surface is inversely proportional to the square of the distance of the surface from the source of light.

Consider a surface of area 'A' situated at a distance r from a point source P as shown in Fig. 19.7. Let the area project a solid angle Ω at point P and the flux in this solid angle be F .

$$\therefore \text{Intensity } I = \frac{F}{\Omega} = \frac{F}{A/r^2} \quad \text{and Flux } F = \frac{A}{r^2} I \quad \dots(19.9)$$

$$\text{Illuminance } E = \frac{\text{flux}}{\text{area}} = \frac{F}{A} = \frac{I}{r^2} \quad \dots(19.10)$$

Therefore illuminance of a surface from a light source of constant intensity is inversely proportional to square distance of surface from the source.

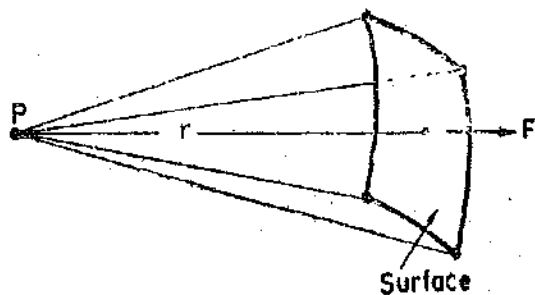

Fig. 19.7

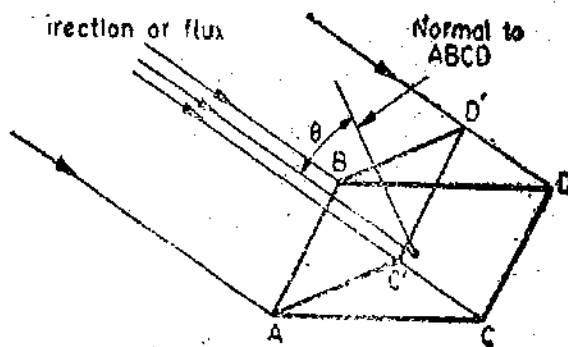

Fig. 19.8

2. Lambert's Cosine Law. Fig. 19.8 shows a surface $ABCD$ illuminated by a luminous flux in a direction θ to the normal to the direction of flux.

Let the flux in the beam be F and area $ABC'D'$ be A .

\therefore Area of $ABCD = A/\cos \theta$. The same flux falls on the two surfaces.

$$\therefore \text{Illuminance of } ABCD = \frac{F}{A/\cos \theta} = \frac{F \cos \theta}{A} \quad \dots(19.11)$$

Thus the illuminance of a surface is proportional to the cosine of the angle between its normal and the direction of the luminous flux. For a point source of constant I in all directions, the two laws lead to the following expression for the illuminance at any point P of Fig. 19.9.

$$E = \frac{I \cos \theta}{r^2} \quad \dots(19.12)$$

$$= \frac{I}{(x^2+h^2)} \cdot \frac{h}{\sqrt{x^2+h^2}} = \frac{I \cdot h}{(x^2+h^2)^{3/2}} \quad \dots(19.13)$$

$$= \frac{Ih}{r^2} = \frac{I}{h^2} \cos^3 \theta \quad \dots(19.14)$$

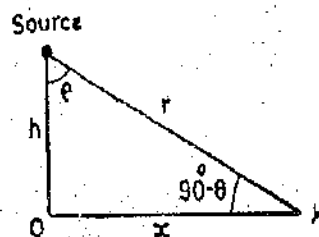

Fig. 19.9

Example 19.3. Six lamps are used to illuminate a certain room. If the luminous efficacy of each lamp is 11 lm/W and the lamps have to emit a total flux of 10,000 lm, calculate (a) the m.s.l.i. per lamp, (b) the cost of energy consumed in four hours if the charge for electrical energy is 50 p per unit.

Solution. Luminous flux of each lamp : $F = \frac{10,000}{6} = 1666 \text{ lm.}$

Mean spherical luminous intensity (m.s.l.i.) of each lamp $I = \frac{F}{\Omega} = \frac{1666}{4\pi} = 132.6 \text{ cd.}$

Power of six lamps = $\frac{10,000}{11} = 909 \text{ W.}$

Energy consumed = $\frac{909 \times 4}{1000} = 3.64 \text{ kWh.}$

Cost of energy = $\frac{50}{100} \times 3.64 = \text{Rs. } 1.82.$

Example 19.4. The effective area of the filament of a certain pearl type of lamp, when viewed from below is $2 \times 10^{-3} \text{ m}^2$, and the luminous intensity in the downward direction is 153 cd. Calculate the luminance of the lamp when viewed from that direction.

Solution.

$$\text{Luminance } L = \frac{1}{\cos \theta} \times \frac{dI}{dA} = \frac{1}{1} \times \frac{153}{2 \times 10^{-3}} = 76500 \text{ cd/m}^2.$$

Example 19.5. A lamp having a mean spherical luminous intensity of 80 cd has 70% of light reflected uniformly on to a circular screen 3 m in diameter. Find the illuminance on the screen.

Solution. Effective m.s.l.i. of lamp $I = 0.7 \times 80 = 56$ cd.

Luminous flux emitted by source $F = 4\pi I = 4\pi \times 56 = 702$ lm.

$$\text{Illuminance } E = \frac{F}{A} = \frac{702}{\pi/4 \times (3)^2} = 99.5 \text{ lx.}$$

Example 19.6. A circular area of radius 6 m is to be illuminated by a single lamp vertically above the circumference of the circle. The minimum illuminance is to be 6 lx and the maximum illuminance 20 lx. Find the mounting height and mean spherical luminous intensity of the lamp. Assume m.s.l.i. to be uniform in all directions.

Solution. Let $I =$ m.s.l.i. of the lamp ; cd, $h =$ height at which the lamp is hung ; m,
and $D =$ diameter of circle ; m.

$$\text{From Eqn. 19.13, Illuminance } E = \frac{Ih}{(x^2 + h^2)^{3/2}}.$$

The maximum illuminance occurs just below the place where the lamp is hung.

For this place $x = 0$.

$$\therefore \text{Maximum illuminance : } E = \frac{Ih}{h^3} = \frac{I}{h^2} \quad \text{or} \quad 20 = \frac{I}{h^2} \quad \text{or} \quad I = 20h^2 \quad \dots(i)$$

Minimum illuminance occurs at a diametrically opposite point and for this point $x = D$.

$$\text{Minimum illuminance : } E = \frac{Ih}{(D^2 + h^2)^{3/2}} \quad \text{or} \quad 6 = \frac{20h^3}{(12^2 + h^2)^{3/2}} \quad \dots(ii)$$

Solving (i) and (ii), we have : $h = 10.82$ m and $I = 2340$ cd.

Example 19.7. The illumination level of a field on account of sunlight when the sun is at 45° above the horizon is 60,000 lx. How much illumination will be produced by sunlight under identical conditions, when the sun reaches an altitude of 60° .

Solution. From Eqn. 19.12.

$$\text{Illuminance (illumination) } E = \frac{I \cos \theta}{r^2}.$$

When the sun is 45° to horizon, the angle which the direction of radiation makes with the normal to the surface to be illuminated is $\theta = 90^\circ - 45^\circ = 45^\circ$.

$$\therefore 60,000 = \frac{I \cos 45^\circ}{r^2} \quad \text{or} \quad \frac{I}{r^2} = \frac{60,000}{\cos 45^\circ}.$$

When the sun is 60° above the horizon $\theta = 90^\circ - 60^\circ = 30^\circ$.

The distance r , to the sun and also the luminous intensity I are the same in both the cases. Therefore illumination (illuminance) of the field when the sun is 60° above horizon is

$$E = \frac{I}{r^2} \cos 30^\circ = 60,000 \frac{\cos 30^\circ}{\cos 45^\circ} = 73,400 \text{ lx.}$$

19.15. Visual Photometry. Photometric measurements which depend upon human eye for judgement of equality of illuminance or luminance are termed as visual photometric measurements.

19'16. **Measurements of Luminous Intensity.** The principle of working of methods for measurement of luminous intensity is based upon the inverse square law. A simplified set up of method for measuring luminous intensity is shown in Fig. 19'10. Two lamps *S* and *T* are placed at a distance apart with some type of screen in between them. *S* is a standard lamp whose intensity is known and *T* is a lamp under test whose intensity is to be determined. The screen is moved in between the lamps till the illuminance (illumination) on both sides of the screen is equal. Under this condition

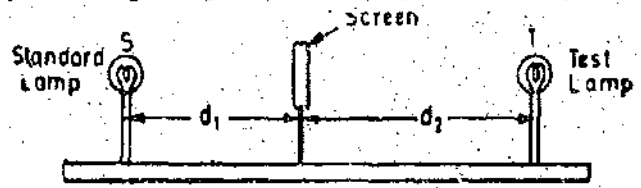

Fig. 19'10. Measurement of luminous intensity.

$$\frac{I_s}{d_1^2} = \frac{I_T}{d_2^2}$$

∴ Intensity test lamp $I_T = I_s \frac{d_2^2}{d_1^2}$... (19'15)

where I_s = Intensity of standard lamp.

The screen used for determining the point of equal illuminance is called "Photometer Head". The graduated bench on which the photometer head slides is called "Photometer Bench".

19'17. **Photometer Heads.** A photometer head consists of a device by means of which the illuminance of two surfaces, side by side may be compared under similar conditions and without moving the eye. One of the surfaces is illuminated by a standard lamp and the other by the lamp under test.

The various photometer heads are explained below :

1. **Bunsen Photometer Head.** It consists of a sheet of opaque white paper in the centre of which a very small spot of grease is placed. The grease spot is translucent. If the paper is illumina-

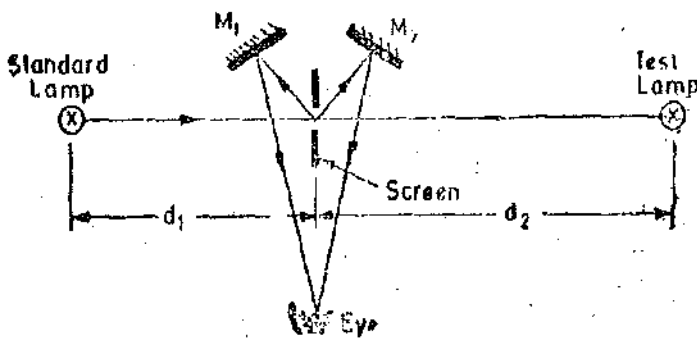

Fig. 19'11. Bunsen photometer head.

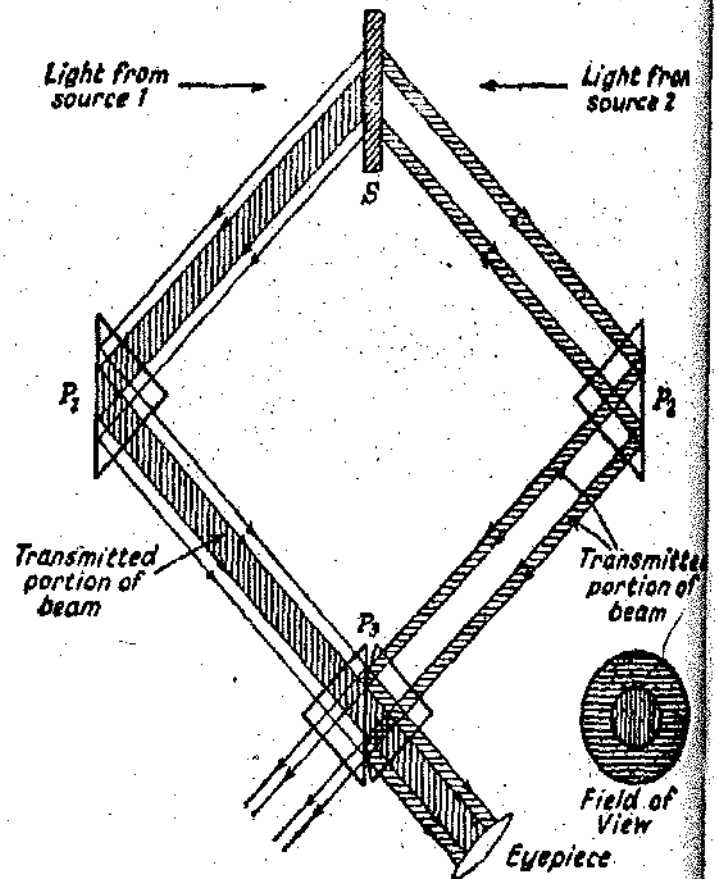

Fig. 19'12. Lummer Brodhun photometer head (comparison type).

ted from one side only then the appearance of that side will be a dark patch at the centre and a bright surrounding, while the appearance on the other side will be a bright central patch with a dark surrounding. If illuminated from both the sides (one side by standard lamp and other by test lamp) there will be a position of the photometer with respect to the sources for which the grease spot disappears when viewed simultaneously from two sides of the paper. Under this condition the

illuminance of two sides of paper are equal. Therefore, intensity of test lamp under test is $I_T = I_s \frac{d_2^2}{d_1^2}$.

The two sides of paper are viewed simultaneously with the help of an arrangement using two mirrors M_1 and M_2 as shown in Fig. 19'11.

2. Lummer-Brodhun Photometer Head

Comparison type. It is a precision head in which the precise demarcation of two halves of the visual field is achieved by optical means. The arrangement is shown in Fig. 19'12. The screen S is matt white screen of plaster of paris. The two sides of this screen are illuminated by the two sources. The two sides are viewed simultaneously by means of the totally reflecting prisms P_1 and P_2 and the Lummer Brodhun prism P_3 . This is a compound prism (P_3) in which the hypotenuse face of one component is flat and the other spherical with a circular flat ground at the middle. Light travelling from P_1 to P_3 passes straight through the contact surface and reaches the eye piece, the resulting field of view being a circle. Light travelling from P_2 to P_3 also passes through the contact surface and therefore does not reach eye. Light which is outside this transmitted central beam is totally reflected and therefore passes through the eye piece to form in the field of view an annular ring round the circle formed by the light from P_1 . The paths of rays are shown in the diagram. The photometer head is moved until the dividing line between the central circle and the annular ring of light disappears. Thus the arrangement gives the same effect as the grease spot photometer head. The intensity of the unknown source may be calculated in a similar manner as explained earlier.

Contrast type. A simple modification converts the equality of illumination prism into a contrast prism. The hypotenuse faces of the two component prisms are now flat and one of them is etched with trapezoidal pattern as shown in Fig. 19'13. Where the two faces are in contact, light from either side is transmitted but where the etching causes a physical separation there is total reflection. The resulting field of view is shown in Fig. 19'13. There is an additional modification in the form of two glass plates G_1 and G_2 arranged so that, because of the additional reflection set up, the illumination of the trapezoidal patch on the right hand side of the field will be somewhat less than that of surrounding field on the left hand side and *vice versa*. Denoting the difference by $x\%$ it follows that at balance, the contrast between the trapezoidal patch and its surrounding will be $x\%$ on each side.

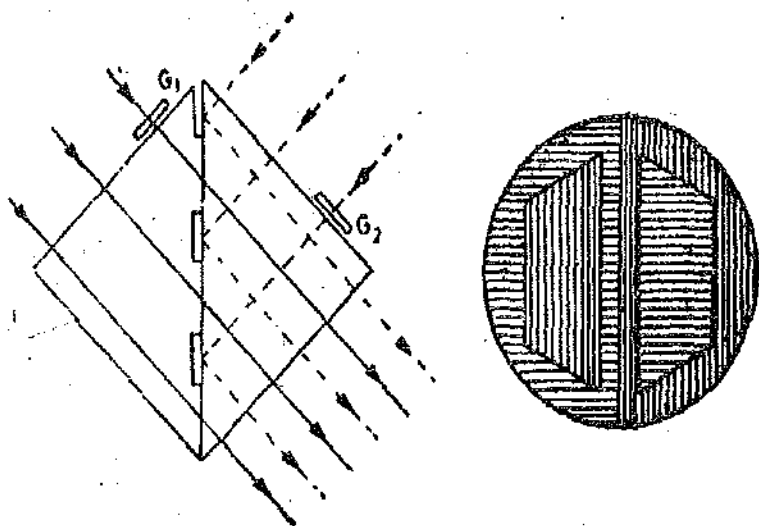

Fig. 19'13. Lummer Brodhun Photometer Head (Contrast Type).

The contrast instrument is preferable to other because the fusion of two halves of an equality of illumination field does not lead to a high degree of accuracy of judgement as does equality of contrast.

The photometers described above are used for sources of the same colour.

3. **Flicker Photometer Head.** It will be appreciated that, when the field of view is illuminated by both sources at the same time, and the colour appearances of the two halves of field are exactly the same, the only factor calling for judgement of the part of the observer is the criterion of equal luminosity or equal contrast according to the photometer used. However, if the two sources are of two different colours, this factor of colour will introduce a factor of uncertainty.

In a flicker photometer the field of view is illuminated alternately, and in rapid succession, by the two sources. Thus the illumination at any particular instant is due to two sources only. If the screen luminosities due to two sources are different, then there will be flicker due to both the causes, *i.e.* due to difference in luminosity and colour. If the speed of the flicker is gradually raised from a low value, it is found that the flicker due to colour difference disappears before that due to luminosity difference.

The photometer can thus be used for :

- (i) the measurement of intensity of unknown source with a standard source of same colour,
- (ii) for the measurement of intensity of unknown source with a standard source of different colour. In this case there must first of all be adjustment of the speed till the colour difference disappears and then the normal photometric adjustments are made for getting minimum flicker.

Fig. 19'14 shows a flicker photometer. One light source illuminates a white diffusing screen *S* through a prism *P*. The other source illuminates a rotating sector *F*. This sector also has a

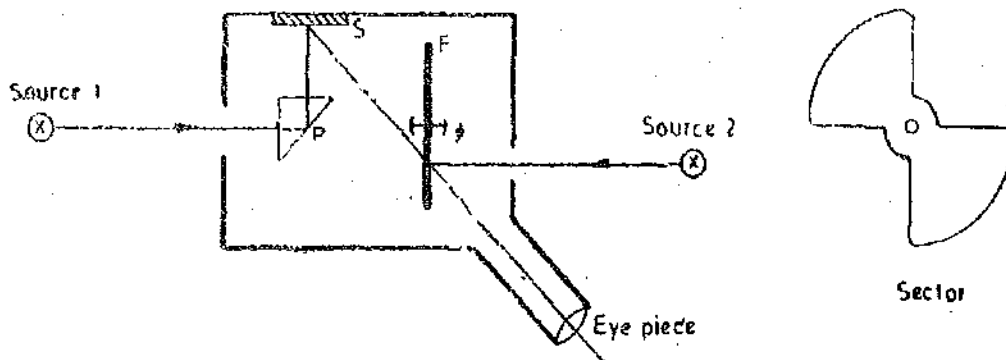

Fig. 19'14. Flicker photometer.

white diffusing surface. When the sector revolves the eye sees the screen *S* and sector *F* alternately. The distances of sources from the photometer head are varied till minimum flicker is observed. The intensity of the test source is determined by the inverse square law.

19'18. **Distribution of Luminous Intensity.** In the discussions above, we have considered the intensity of the source in only one direction. However, in most lamps and sources of light, the luminous intensity is not the same in all the directions. Therefore, it is important that the intensity distribution in a number of directions round the source is known. The intensity distribution measurements are made to determine the mean horizontal intensity and the mean spherical intensity.

19'19. **Determination of Mean Horizontal Luminous Intensity and Polar Curve.** This may be determined for any source by turning it about a vertical axis and measuring intensity in the direction of the line joining the source under test and the standard source. The readings are taken after 10' to 15' of rotation. A polar curve is plotted as shown in Fig. 19'15 from the results obtained from measurements. This curve is horizontal distribution curve of intensity. The mean horizontal luminous intensity may be obtained by plotting the intensity against the angle of rotation on rectangular axis as shown in Fig. 19'16. The mean ordinate of this curve gives the value of mean horizontal intensity.

The mean horizontal intensity may also be obtained with a single measurement if the source under test is continuously revolved about its vertical axis at a speed of about 200 rpm.

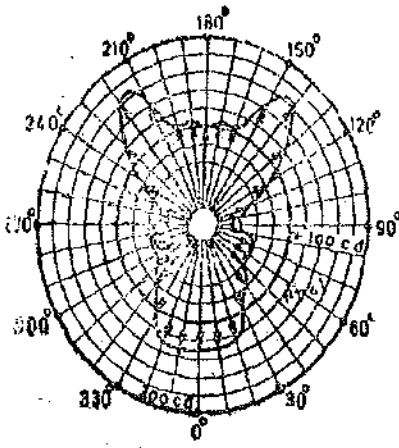

Fig. 19.15

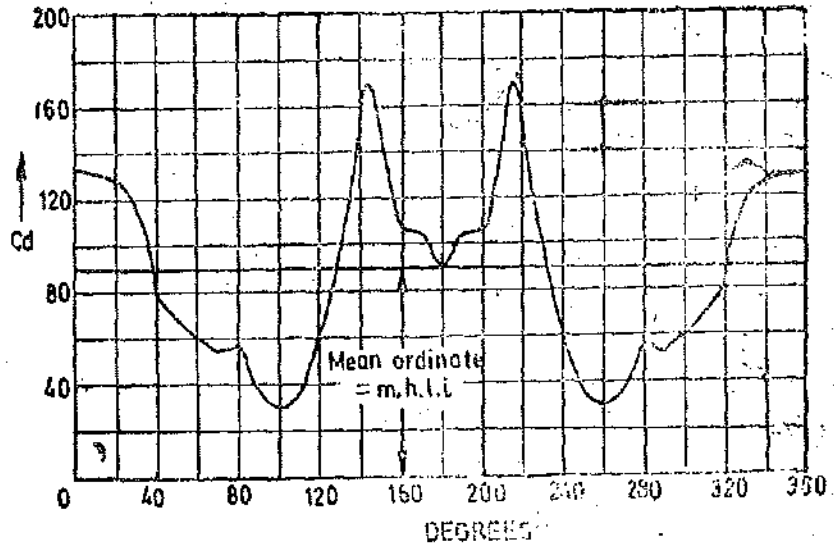

Fig. 19.16. Determination of m.h.l.i.

19.20. Determination of Mean Spherical Luminous Intensity. The mean spherical luminous intensity is obtained from the intensity distribution curve in a vertical plane. This distribution curve is obtained from intensity measurements done by tilting the lamp in a vertical plane after intervals of 10° to 15° .

The mean spherical luminous intensity may be obtained graphically from the distribution curve with the help of the following :

(i) **Rosseau's Construction.** Suppose the vertical distribution curve (polar curve) is in the form of two lobes symmetrical about an axis YOY' (Fig. 19.17).

Draw a circle with any convenient radius with O as centre. Draw CD parallel to YOY' and equal to it. Draw a line inclined at an angle θ . Draw angle $d\theta$ also. Draw any line OFA meeting the polar curve at F and the circle in A . Project A on CD . Let the projection be G . At G erect an ordinate $GH=OF$. By similar construction complete the curve $CLHB$. This is called Rosseau's curve. The mean height of this curve

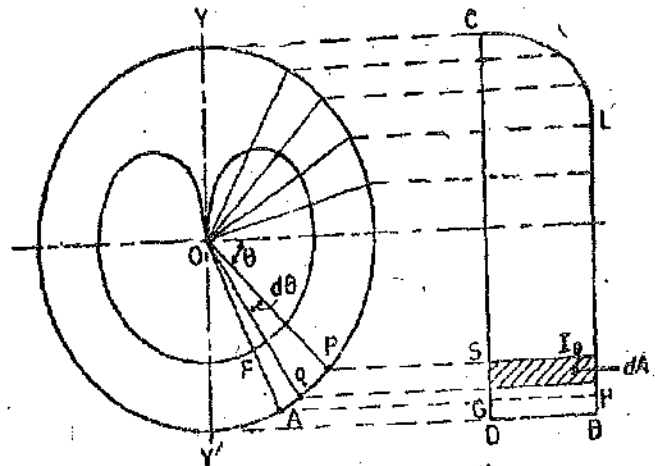

Fig. 19.17. Rosseau's construction.

$$\frac{\text{area } CLHBD}{\text{length } CD}$$

gives the mean spherical intensity of the test source.

Let the intensity of illumination be I_0 at any angular position θ . Consider a differential angle $d\theta$ and rotate it about the axis YOY' . This rotation produces a zone of a sphere of area $2\pi (r \cos \theta) (r d\theta) = 2\pi r^2 \cos \theta d\theta$ since $r \cos \theta$ is the radius of the zone in a horizontal plane and $r d\theta$ is the width of zone.

Solid angle subtended by this zone, at the centre O

$$d\Omega = \frac{2\pi r^2 \cos \theta d\theta}{r^2} = 2\pi \cos \theta d\theta.$$

Luminous flux on this zone $dF = I_0 d\Omega = 2\pi I_0 \cos \theta d\theta$

$$\text{Total luminous flux emitted by source } F = \int_{-\pi/2}^{+\pi/2} 2\pi I_{\theta} \cos \theta d\theta$$

But as I_{θ} itself is a function of θ , the above integral cannot be evaluated easily.

Mean spherical luminous intensity

$$I_{mean} = \frac{F}{4\pi} = \frac{2\pi}{4\pi} \int_{-\pi/2}^{+\pi/2} I_{\theta} \cos \theta d\theta = \frac{1}{2} \int_{-\pi/2}^{+\pi/2} I_{\theta} \cos \theta d\theta \quad \dots(19'16)$$

Now refer to Rosseau's construction of Fig. 19'17 and Fig. 19'18.

$$pq \sim eq \quad \alpha + \beta = 90^\circ = \beta + \theta \quad \therefore \alpha = \theta$$

$$\text{Hence } st = pq \cos \alpha = pq \cos \theta = (r d\theta) \cos \theta.$$

$$\text{We have } dA = st I_{\theta} = (r \cos \theta d\theta) I_{\theta}.$$

$$\text{Area under curve } CLHBD = \int_{-\pi/2}^{+\pi/2} dA = \int_{-\pi/2}^{+\pi/2} I_{\theta} (r \cos \theta) d\theta$$

$$\text{Mean height of this curve} = \frac{\text{area}}{\text{base}} = \frac{1}{2r} \int_{-\pi/2}^{+\pi/2} I_{\theta} (r \cos \theta) d\theta = \frac{1}{2} \int_{-\pi/2}^{+\pi/2} I_{\theta} \cos \theta d\theta$$

Thus the mean spherical intensity can be found by finding the mean ordinate of Rosseau's curve.

The mean hemispherical intensity of the source may be obtained by using Rosseau's construction for either the upper or lower part of the polar curve of mean vertical distribution.

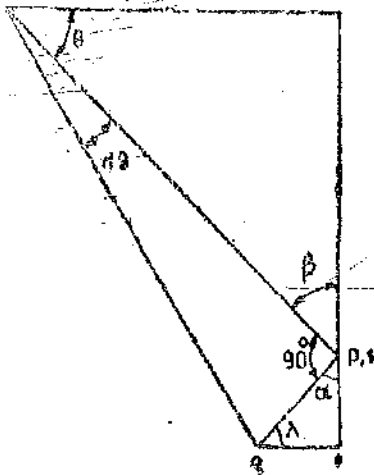

Fig. 19'18

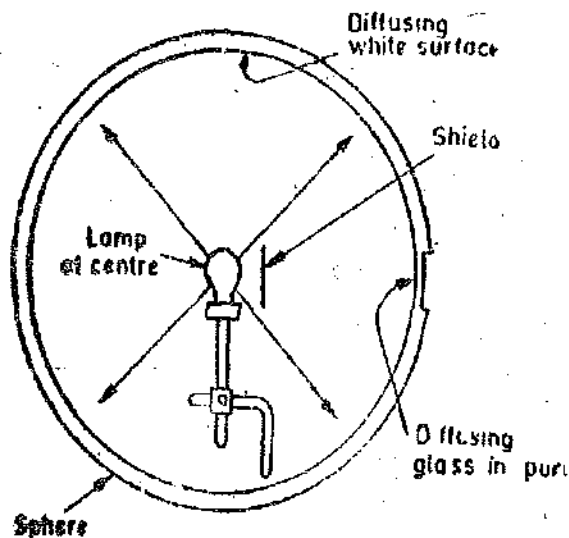

Fig. 19'19. Integrating sphere.

(ii) Integrating sphere. The Ulbricht integrating sphere, (Fig. 19'19), is generally used to measure the mean spherical luminous intensity of electric lamps. The lamp is located at the centre of the sphere. The inside walls of the sphere are coated with white diffusing material, such as magnesium oxide or a specially prepared sphere paint. The lamp illuminates the side walls nearly uniformly and the multiple reflections within the sphere cause every portion of the inside surface to be equal in luminance. The luminance of this surface is proportional to the total luminous flux and hence to the mean spherical luminous intensity.

This luminance can be measured through a small port, usually the port is covered with a diffusing glass. A small screen adjacent to the lamp prevents its direct light from illuminating the port.

To measure the mean spherical luminous intensity of a lamp, the lamp is placed inside the sphere and the luminance of glass port is measured. A substandard lamp whose mean spherical luminous intensity is known is then substituted for the test lamp and luminance of the window is again measured. The mean spherical luminous intensities of the two lamps are proportional to the corresponding luminances of the glass port.

This sphere can be used for measurement of total luminous flux also.

Total luminous flux $F = 4\pi \times$ mean spherical luminous intensity.

Theory of Integrating Sphere

Let $E =$ indirect illuminance on the surface of sphere ; lx,
 $R =$ radius of sphere ; m.

\therefore Total reflected flux on the inside of sphere $= 4\pi R^2 E$.

Suppose the direct flux is F lumen, and reflection factor is ρ .

Reflection factor is defined as :

$$\text{Reflection factor } \rho = \frac{\text{reflected luminous flux}}{\text{incident luminous flux}} \quad \dots(19'17)$$

\therefore Luminous flux absorbed $= (F + 4\pi R^2 E)(1 - \rho)$

But luminous flux emitted $=$ luminous flux absorbed

$$\therefore E = (F + 4\pi R^2 E)(1 - \rho)$$

$$\text{or } E = \frac{\rho F}{4\pi R^2(1 - \rho)} \quad \dots(19'18)$$

Hence indirect illuminance is directly proportional to the luminous flux of the source.

We can express the above result in terms of luminance.

$$\text{Luminance } L = \frac{\rho E}{\pi} \quad \dots(19'19)$$

$$\text{or } E = \frac{\pi L}{\rho} \quad \dots(19'20)$$

Thus from Eqns. 19'18 and 19'20,

$$\text{Luminance } L = \frac{\rho^2 F}{4\pi^2 R^2(1 - \rho)} \quad \dots(19'21)$$

19'20. Calculations with a Distributed Source. When the source of light is extended, it is convenient to find the illuminance due to luminous intensity of an element of the surface by means of inverse square law, and then integrate over the whole surface.

A uniform diffuser is shown in Fig. 19'20. When dealing with a Uniform Diffuser, i.e., a source which has same luminance in all directions, the following relationships may be found convenient.

Let $A =$ area of the surface ; m²,
 $I_n =$ luminous intensity in a direction normal to the surface ; cd,

and $I_\theta =$ luminous intensity in a direction at an angle θ to the normal.

Luminance normal to the surface

$$L_n = \frac{I_n}{A} \text{ as } \theta = 0 \text{ and } \cos \theta = 1 \quad (\text{See Eqn. 19'7})$$

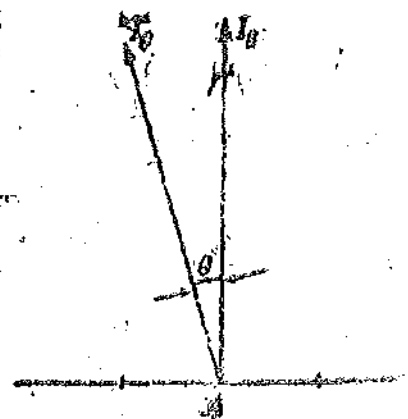

Fig. 19.20

and luminance at an angle θ to normal $L_{\theta} = \frac{I_{\theta}}{A \cos \theta}$.

Since we have a uniform diffuser, $L_{\theta} = L$.

or
$$\frac{I_{\theta}}{A \cos \theta} = \frac{I_n}{A} \quad \text{or} \quad I_{\theta} = I_n \cos \theta \quad \dots(19'22)$$

A fluorescent lamp may be considered to be a uniformly diffusing cylinder. From Eqn. 19'16, mean spherical luminous intensity of the cylinder is :

$$I = \frac{1}{2} \int_{-\pi/2}^{+\pi/2} I_{\theta} \cos \theta \, d\theta = \frac{1}{2} \int_{-\pi/2}^{+\pi/2} I_n \cos^2 \theta \, d\theta = \frac{\pi}{4} I_n.$$

\therefore Total luminous flux $F = 4\pi \times \frac{\pi}{4} I_n = \pi^2 I_n \quad \dots(19'23)$

For a plane uniform diffuser ;
total luminous flux $F = \pi I_n$

$\dots(19'24)$

Example 19'8. (a) In a photometric bench test balance is obtained when a standard lamp of 25 cd in the horizontal direction is 1 m and the lamp being tested is 1'25 m from the photometer screen. What is the luminous intensity of the test lamp ?

(b) If the light from the test lamp is reduced by 15 percent what will be the respective distances of lamps from the photometer screen ? In this case the lamps are fixed 2'5 m apart, and the photometer screen moves between them.

Solution. (a) Luminous intensity of test lamp $I_T = I_S \frac{d_2^2}{d_1^2} = \frac{25 \times (1'25)^2}{(1'0)^2} = 39'1 \text{ cd.}$

(b) Intensity of test lamp, $I_T = 0'85 \times 39'1 = 23'2 \text{ cd.}$

Using Eqn. 19'15, we have, $\frac{d_2}{d_1} = \left(\frac{I_T}{I_S}\right)^{\frac{1}{2}} = \left(\frac{23'2}{25}\right)^{\frac{1}{2}} = 1'15.$

But $d_1 + d_2 = 2'5 \text{ m}$ or $2'15d_1 = 2'5$

\therefore Distance of standard lamp from photometer screen $d_1 = \frac{2'5}{2'15} = 1'16 \text{ m.}$

Distance of test lamp from photometer screen $d_2 = 2'5 - 1'16 = 1'34 \text{ m.}$

Example 19'9. If an Ulbricht sphere 30 cm in radius, whose inner surface has a reflection factor of 0'84, contains a lamp producing on the portion of the sphere screened from direct radiation a luminance of 1300 cd/m², calculate the luminous flux of the light source.

Solution. Using Eqn. 19'21, luminous flux of light source

$$F = \frac{4\pi^2 R^2 (1-p)L}{\rho^2} = \frac{4\pi^2 \times (0'3)^2 (1-0'84) \times 1300}{(0'84)^2} = 1040 \text{ lm.}$$

19'21. Physical Photometry. Photometric measurements which do not depend upon the human eye for the judgement of equality of luminance utilize photo-electric devices explained below. A photo-electric device is a piece of apparatus which allows the flow of current only when light falls on the device. Also the magnitude of the current varies with the intensity of light and hence these devices can be used for photometric measurements. The different photo-electric devices are :

- (i) Photo emissive cells ;
- (ii) Photo conductive cells ;
- (iii) Photo voltaic cells.

19'22. Photo-emissive Cells. Fig. 19'21 shows a highly evacuated photo-emissive cell. Light radiation strikes the cathode (Fig. 19'21) and interacts with the electrons in the metal whereby the entire energy of a light quantum is converted into the kinetic energy of the electron. Kinetic energy of electron is :

$$W = \frac{h c}{\lambda}$$

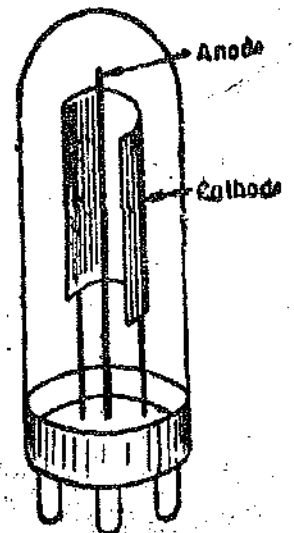

Fig. 19'21. Photo-emissive cell.

Electrons with sufficient energy to overcome the forces which bind them will be emitted. In the emission process an electron will lose a part of its energy E_w , so that the kinetic energy of the emitted electron is :

$$W' = \frac{h c}{\lambda} - e E_w \quad \dots(19.25)$$

where E_w = work function of the metal ; eV,
and e = charge of one electron ; C.

There is a particular wavelength at which the kinetic energy $W' = 0$. This wavelength is called threshold wavelength. Its value is given by :

$$\lambda_0 = \frac{h c}{e E_w} = \frac{6.63 \times 10^{-34} \times 3 \times 10^8}{1.6 \times 10^{-19} E_w} = \frac{1.24}{E_w} \times 10^{-6} \text{ m} \quad \dots(19.26)$$

and maximum work function $E_w = \frac{1.24 \times 10^{-6}}{\lambda_0} \quad \dots(19.27)$

If the wavelength of the incident radiation is greater than λ_0 , there will be no electron emission. The threshold wavelength of commercial photoelectric emitters is between 600–1200 nm. The cathode materials should have a low value of work function, E_w , (in order to have a high value of λ_0). Combinations of a several alkali metals (which have a low value of E_w) are used for construction of cathodes.

The circuit shown in Fig 19.23 may be used for measurement of luminous flux or luminous intensity. The current through the tube depends upon the following factors :

- (i) the intensity of light, (ii) The colour or wavelength of light,
- and (iii) the voltage impressed between cathode and anode.

Fig. 19.22 shows current versus voltage (Anode) characteristics of a typical highly evacuated photo tube, when different intensities of light having fixed colour characteristics fall on the tube. A study of these curves shows that for a constant impressed voltage, the current is proportional to the luminous intensity or luminous flux provided same wavelengths are used. The micro-ammeter used in Fig. 19.22 may be directly calibrated in terms of luminous intensity of flux. Else a resistor R be connected in the circuit. The voltage E_0 across the resistor is proportional to the luminous intensity or luminous flux. The output voltage, E_0 , may be amplified modified in subsequent stages.

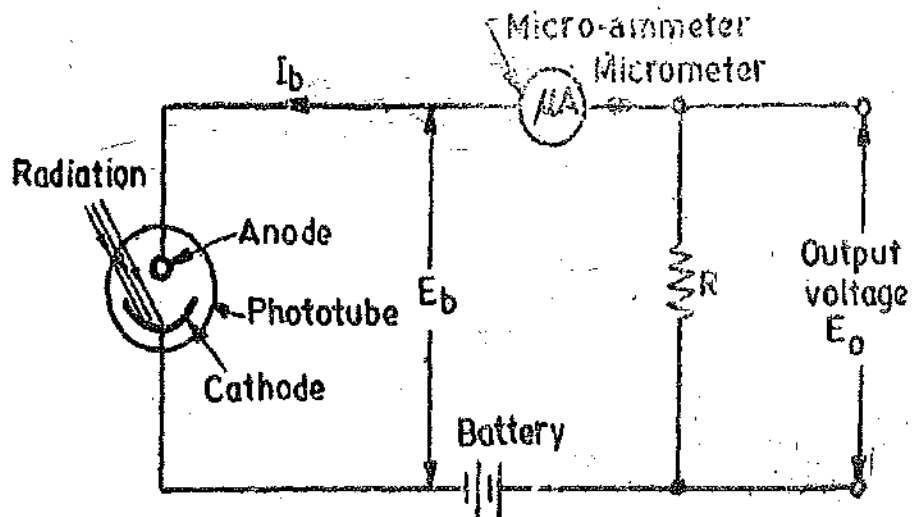

Fig. 19.22. Measurement of luminous flux and luminous intensity using a photo-tube.

Sensitivity. The photoelectric sensitivity is defined as : $I_b = SF \quad \dots(19.28)$

where I_b = photoelectric current, F = light flux, and S = sensitivity

The light flux F can be expressed in terms of watt or in terms of lumen. Correspondingly, the sensitivity has two type of units.

Radiant Sensitivity is expressed in terms of ampere per watt while Luminous Sensitivity is expressed in terms of ampere per lumen. The vacuum photoelectric cells have a luminous sensitivity of 10 to 100 $\mu\text{A}/\text{lm}$ or a radiant sensitivity of 0.002 to 0.1 A/W .

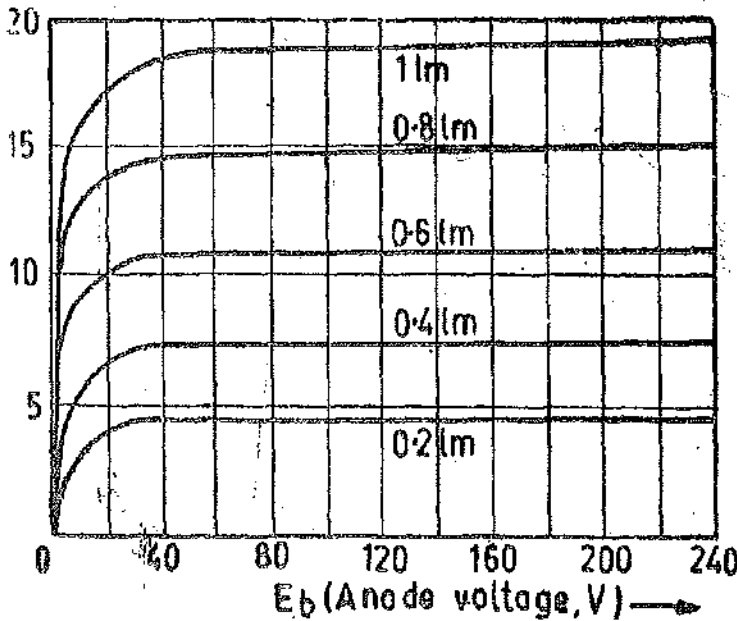

Fig. 19.23. Anode characteristics for a high vacuum photo tube.

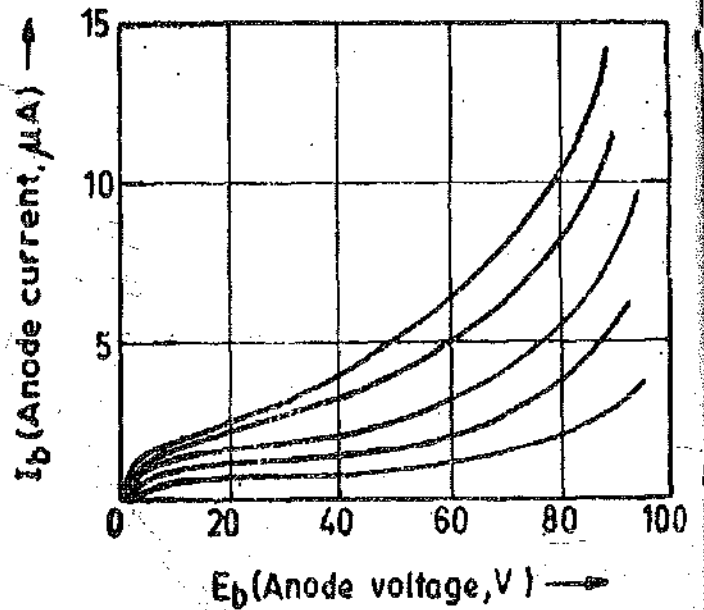

Fig. 19.24. Anode characteristics of a gas filled photoemissive cell.

It is observed that the current through a highly evacuated tube is very small and is of the order of μA . This current can be increased 5 to 10 times by using gas filled cell. A gas filled cell generally contains an inert gas at a pressure of 1 mm of mercury. Fig. 19.24 shows the characteristics of a gas filled cell. A resistance should always be inserted in the circuit of gas filled cell in order to limit the current because if the applied voltage increases beyond the critical value due to some cause, a glow discharge may start that will damage the cell. This means that the gas filled photoemissive tube can be used only over a limited range of voltage. Other disadvantages of gas cells are :

- (i) They are not as stable as vacuum cells.
- (ii) Their characteristics are non-linear.
- (iii) They exhibit a time lag in response to a light pulse which has the effect of reducing the response to modulated or chopped light at frequencies above 10 kHz.

Noise. Various noise effects are present in photoelectric tubes. The output of a photoelectric cell illuminated by a constant flux is not pure d.c. voltage but fluctuates randomly about an average value. The fluctuation of the output voltage, i.e., the Shot Noise, can be considered an a.c. voltage with a uniform distribution over the frequency spectrum. The noise output voltage caused by shot effect is :

$$E_s = \sqrt{3.2 \times 10^{-19} I_0 R^2 \Delta f} \text{ volt.} \quad \dots(19.29)$$

where I_0 = average emission current of cell ; R = resistance ; Ω , Δf = frequency band, Hz.

In addition to shot noise, Johnson's noise is present in the resistor due to thermal agitation in resistors. Johnson's noise voltage is given by : $E_{TH} = \sqrt{4k TR \Delta f}$ volt

$$\text{At room temperature } E_{TH} = \sqrt{1.6 \times 10^{-20} R \Delta f} \text{ volt.} \quad \dots(19.30)$$

The total noise voltage comprising of the voltage due to shot effect and due to thermal agitation is : $E_N = \sqrt{3.2 \times 10^{-19} R(I_0 R - 0.05) \Delta f}$ volt. ... (19.31)

19.23. Photomultiplier. Extremely low levels of luminous intensity can be measured or

detected by means of a photomultiplier tubes which utilize many successive stages or secondary emission to boost up the output currents from its initial very low value.

A photomultiplier tube is shown in Fig. 19'25. When light strikes a photo-sensitive cathode, it emits electrons. The liberated electrons are accelerated by a voltage E_1 and are focussed on to the next electrode, D_1 , called Dynode. These electrons striking upon the dynode cause the emission of secondary electrons.

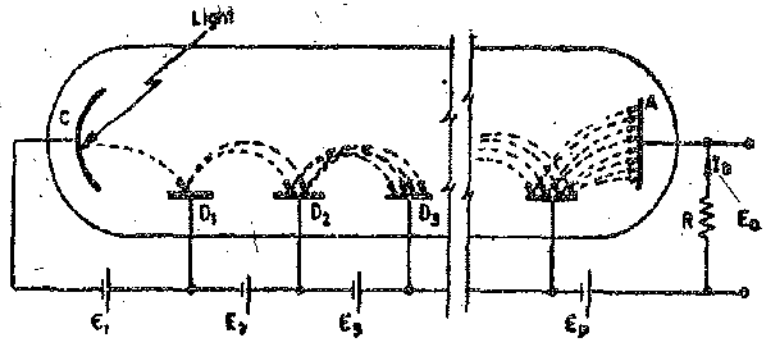

Fig. 19'25. Photomultiplier tube.

The dynodes are so shaped and placed that the electrons always move in the proper direction and are accelerated sufficiently between dynodes to cause secondary emission at each surface.

The process done at dynode D_1 is repeated at subsequent dynodes D_2, D_3, \dots . The final electrode in the series is an anode A which collects all the electrons. The electrode a is at a positive potential and the anode current I_a is measured.

Let the number of electrons formed by secondary emission for each primary electron be g . Therefore, the gain of each stage is : gain = g .

If there are ' n ' dynodes, the total amplification : $A_n = g^n$ (19'32)

The value of g varies with the voltage between successive dynodes and with the surface composition and the geometry of dynodes from a value of 0.5 to 10. The value of stages of commercial multipliers is between 9 to 14. The gain A_n is between 10^5 to 10^7 . The sensitivity of a photomultiplier may be as high as 20A/lm as compared with 100 μ A/lm for photoelectric cells.

Example 19'10. The total irradiance from the sun is 1000 W/m². Our eyes respond to only 14 per cent of this energy. Calculate the value of illuminance.

Solution. Illuminance $E = 0.14 \times 1000 = 140$ W/m².

Example 19'11. Show that for photoelectric emission to be possible over the whole visible region of 4000Å° to 8000Å°, the work function of the photoemissive surface should be less than 1.5 eV.

Solution. For photoelectric emission to take place between 4000Å° to 8000Å° or 0.4 μ m and 0.8 μ m, the maximum work function

$$E_w = \frac{1.24 \times 10^{-6}}{\lambda_0} \quad (\text{See Eqn. 19'27})$$

and the threshold wavelength $\lambda_0 = 0.8 \mu\text{m}$.

$$\therefore \text{Maximum value of work function } E_w = \frac{1.24 \times 10^{-6}}{0.8 \times 10^{-6}} = 1.5 \text{ eV.}$$

Example 19'12. Determine the threshold wavelength in the case of caesium surface for which the work function is 1.8 eV.

Solution. From Eqn. 19'26, the threshold wavelength is :

$$\lambda_0 = \frac{1.24 \times 10^{-6}}{E_w} \text{ m} = \frac{1.24 \times 10^{-6}}{1.8} = 0.689 \times 10^{-6} \text{ m} = 6890 \text{ \AA}.$$

Example 19'13. Determine the maximum velocity of the emitted photoelectrons when a molybdenum surface having a work function of 4.3 eV is irradiated with mercury light having a wavelength of 2537 Å°. The e/m ratio is 0.176×10^{12} C/kg.

$$\text{Solution. Energy} = \frac{1.24 \times 10^{-6}}{\lambda} = \frac{1.24 \times 10^{-6}}{2537 \times 10^{-10}} = 4.89 \text{ eV.}$$

The maximum energy of emitted electron $E_w = 4.89 - 4.3 = 0.59$ eV.

This becomes the kinetic energy and kinetic energy of electrons is $\frac{1}{2} m v^2$. This is equal to $e E_w$.

or velocity $v = \sqrt{\frac{2e E_w}{m}} = \sqrt{2 \times 0.176 \times 10^{12} \times 0.59} = 0.456 \times 10^6$ m/s.

Example 19.14. Find the sensitivity of a photo multiplier which has 6 stages and the gain per stage is 5. The cathode sensitivity is $24 \mu\text{A/lm}$. If the maximum safe current is 3A, calculate the maximum safe illumination.

Solution. Gain of the multiplier tube $A_n = g^n = 5^6 = 15625$.

Over all sensitivity of multiplier tube $= 15625 \times 24 \times 10^{-6} = 0.375$ A/lm.

\therefore Maximum allowable illumination $= \frac{3}{0.375} = 8$ lm.

19.24. Photoconductive Transducers. The working of one of the most common photodetectors is based upon the change in conductivity of a semi-conducting material with change in radiation intensity. The change in conductivity appears as change in resistance and therefore these devices are photoresistive cells. Thus from the point of view of transduction the resistance changes with light intensity.

The principle of a photoconductive devices can be explained as under :

In a semi-conductor an energy gap exists between conduction electrons and valence electrons. In a semi-conductor photoconductive transducer, a photon is absorbed and thereby excites an electron from valence band to conduction band. As electrons are excited from valence band to conduction band, the resistance decreases, making the resistance an inverse function of radiation intensity.

The maximum wavelength is given by :

$$\lambda_0 = \frac{h c}{e E_w} \quad \dots(19.33)$$

Note that any radiation with wavelength greater than that given by Eqn. 19.33 cannot produce any change in the resistance of the semi-conductor.

19.25. Photoconductive Cells. The most two commonly used photoconductive semi-conductor

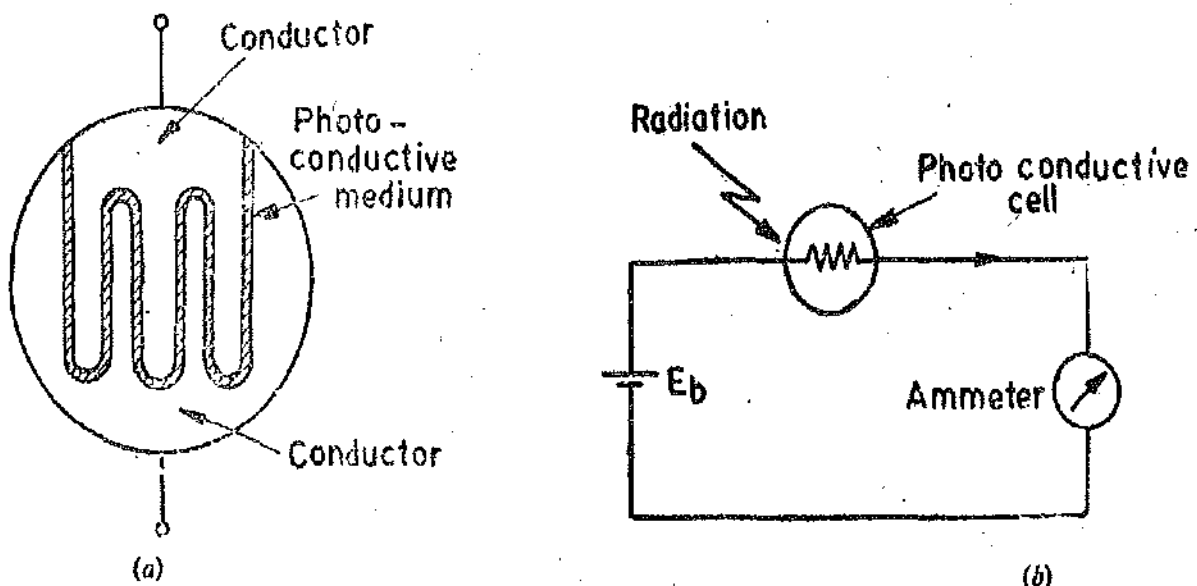

Fig. 19.26. Photoconductive cell and its circuit.

materials are cadmium sulphide (CdS) with a band gap of 2.42 eV and cadmium selenide (CdSe) with a 1.74 eV band gap. On account of these large energy band gaps, both the materials have a very high resistivity at ambient temperature. This gives a very large resistance for practical purposes. A special kind of construction has to be used which minimises resistance while providing maximum

surface. This special type of construction is shown in Fig. 19'26 (a). This construction gives minimum length and maximum area. By using a thin narrow strip and by winding this arrangement back and forth, we get a maximum surface area. The photoconductive material is deposited on a ceramic substrate. The electrodes are of tin or indium.

The basic circuit for the photoconductive cell is shown in Fig. 19'26 (b).

Characteristics of Photoconductive Cells. The characteristics of photoconductive cells vary considerably depending upon the type of materials used. These characteristics are given in Table 19'2.

TABLE 19'2
Characteristics of Photoconductive Cells

Photoconductor	Time Constant	Spectral Band
CdS	100 ms	0.47–0.71 μm
CdSe	10 ms	0.6–0.77 μm
PbS	400 μs	1–3 μm
PbSe	10 μs	1.5–4 μm

When the cell is kept in darkness, its resistance is called dark resistance. The dark resistance may be as high as $10 \times 10^{12} \Omega$. If the cell is illuminated its resistance decreases. The resistance depends on the physical character of the photoconductive layer as well as on the dimensions of the cell and its geometric configuration. The current depends upon the d.c. voltage applied. The current is of the order of mA.

The spectral response characteristics of two commercial cells are shown in Fig. 19'27. There is almost no response to radiation of a wavelength shorter than 300 nm. Cadmium sulphide cells have a peak response in the green part of the spectrum at 510 nm and can be used in the near infra-red region up to about 750 nm. The maximum response of cadmium sulphoselenide is in the yellow-orange at 615 nm. This can be used in the infra-red region up to about 1000 nm.

The photoconductor device described above is also called a bulk photoconductor. As described earlier, the photoconductor has a very resistance at very low illumination levels, which is of the order of $M\Omega$. The higher the intensity of light, the lower is the resistance. The resistance drops to a few $k\Omega$ when exposed to light. When using a photoresistor for a particular application it is important to select the proper dark resistance as well as the suitable sensitivity. The sensitivity of photoresistive transducer is defined as :

$$S = \frac{\Delta R}{\Delta H} \Omega/W - m^{-2} \quad \dots(19'34)$$

where ΔR = change in resistance ; Ω , and ΔH = change in irradiation ; W/m^2 .
The spectral response of the sensor must match that of the light source.

A photoconductor has a relatively large sensitive area. A small change in light intensity causes a large change in resistance. It is common for a photoconductive element to exhibit a resistance change of 1000 : 1 for a dark to light irradiance change of $5 \times 10^{-3} W/m^2$ to $50 W/m^2$. The relationship between irradiance and resistance is, however, not linear. It is closely an exponential relationship. The result may be written as :

$$R_t = R_i + (R_f - R_i) \left[1 - e^{-t/\tau} \right] \quad \dots(19'35)$$

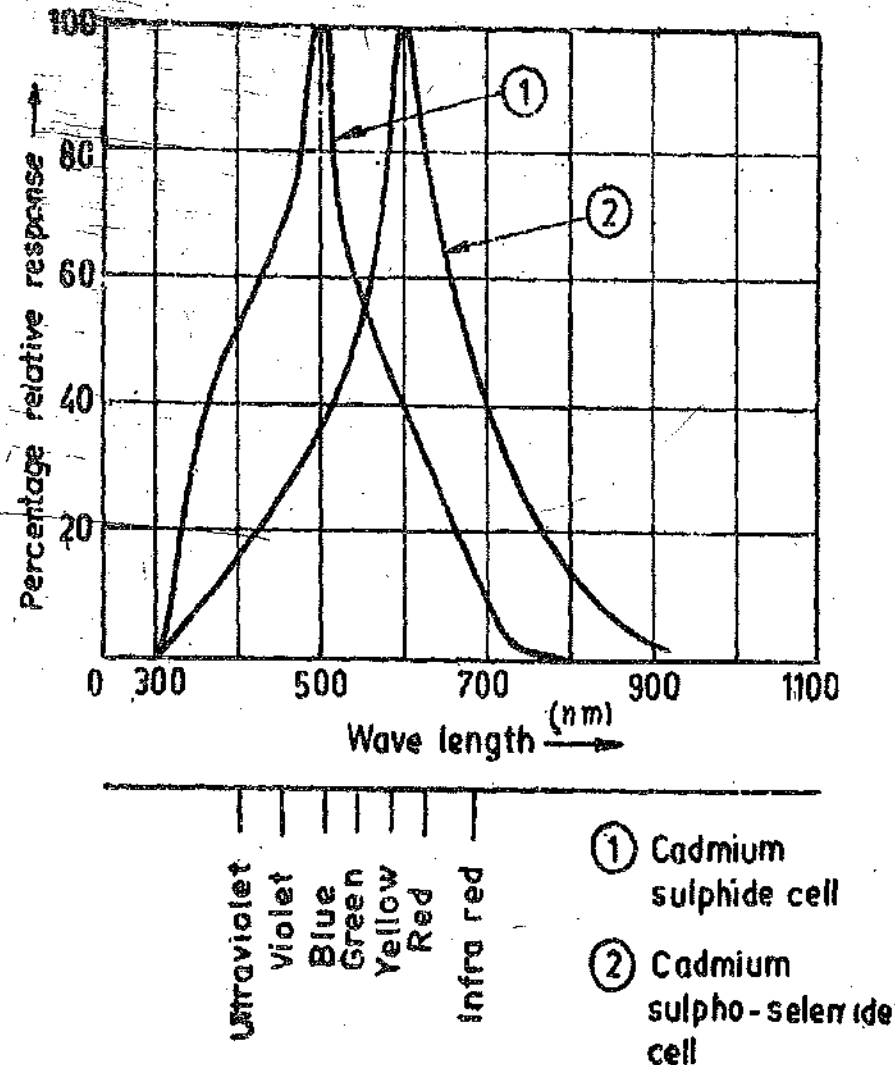

Fig. 19.27. Spectral response characteristics of photoconductive cells.

where R_d = dark resistance ; Ω , R_t = final resistance after application of beam ; Ω ,
 R_i = resistance at any time ; t .

The photoconductive cell suffers from a major disadvantage that temperature changes cause substantial resistance changes for a particular light intensity. Therefore, this type of photoconductor is unsuitable for analog applications.

19.26. Photodiodes

A photodiode incorporates an n and a p type layer. The system has the electrical characteristics of a rectifier. Radiation directed in the vicinity of the $p-n$ junction and cause a flow of current. Fig. 19.28 (a) shows the circuit of a photodiode.

The photodiode is reverse biased. The reverse biased saturation current is dependent upon the intensity of the incident light. Fig. 19.28 (b) shows the typical characteristics of a photodiode. The photodiode is very useful for applications where the space is restricted. The effective area of a photodiode is about 0.2 mm^2 and it has a pinhead (serving as electrode) of a diameter of 0.5 mm .

The frequency response of a photodiode is largely dependent upon the intrinsic capacity which is high for low bias and large for reverse bias. The capacity is typically 2 pF for a reverse bias of -10 V .

The cutoff frequency is given by : $f_c = \frac{1}{2\pi R_L C}$... (19.36)

where R_L = load resistance ; Ω . and C = photodiode capacitance ; F .

The cutoff frequency is of the order of MHz. It should be noted that the photodiode can be operated with 0-V reverse bias. This gives a large capacitance and hence a lower cutoff frequency. The deterioration in frequency response is 5 : 1.

The photocurrent versus light relationship is linear over a wide range. In order to maintain the linearity the bias voltage should be kept constant.

From Fig. 19'28 (b) it is clear that the output resistance $R = \Delta V / \Delta I$, is very high and is of the order of tens of $M\Omega$. The d.c. resistance, V/I , is the diode leakage resistance and that too is very high. This d.c. resistance depends upon the light intensity.

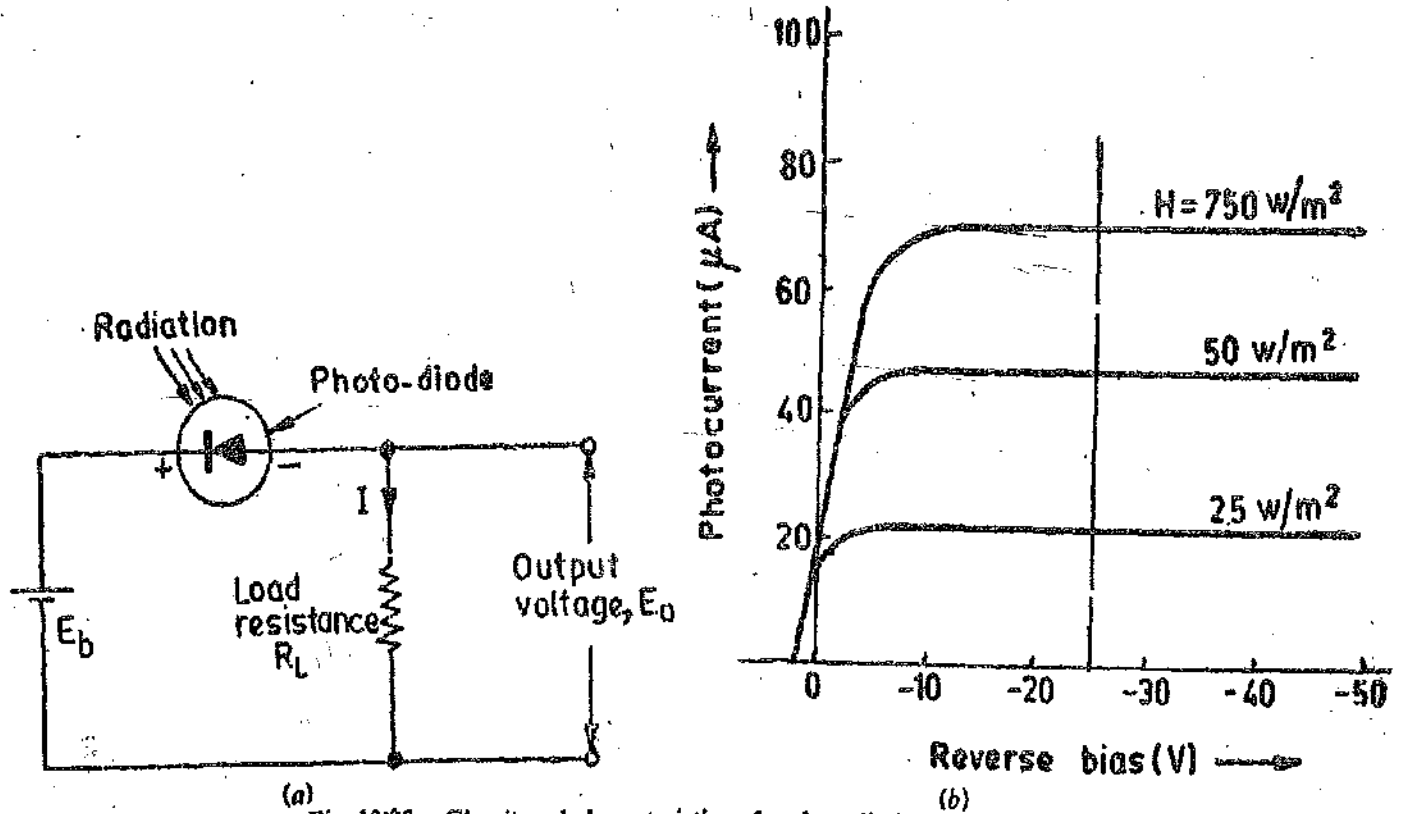

Fig. 19'28. Circuit and characteristics of a photodiode.

19'27. Phototransistor. A phototransistor is a transistor whose collector current depends upon the incident light. The characteristics of a typical phototransistor are shown in Fig. 19'29.

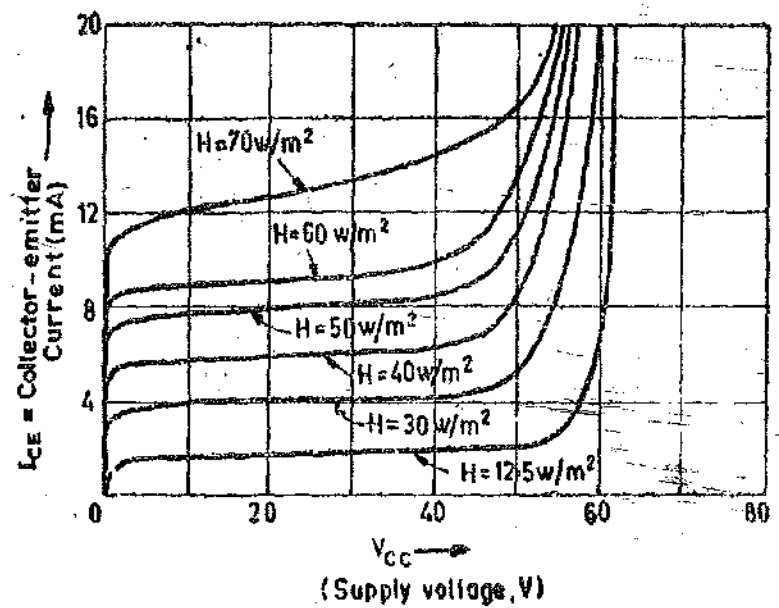

Fig. 19'29. Characteristics of a phototransistor.

A phototransistor gives a high gain. This transistor is very good for digital applications because of the small rise and fall times. The rise time, which represents the response to dark-to-light irradiance is about 1 μ s and the fall time which represents light-to-dark light irradiance is about 10 μ s.

19'28. Noise in Photoconductor Transducers

Photoconductive transducers have a wide range of application and are useful for measurement of radiation at all wavelengths. It is observed that when making measurements at long-wavelengths, many difficulties are observed.

The responsivity of a detector is defined as :

$$R = \frac{\text{rms output voltage}}{\text{rms incident power upon the detector}} = \frac{E_o}{W} \quad \dots(19'37)$$

where E_o = output voltage, and W = incident power.

The noise equivalent power (NEP) is defined as the minimum radiation input that will produce a signal to noise (S/N) ratio of unity.

The detectivity is defined as :

$$D = \frac{R_v}{\text{rms noise voltage of cell}} = \frac{E_o}{WE_N} \quad \dots(19'38)$$

where E_N = rms noise voltage. The detectivity is the reciprocal of NEP.

The normalized detectivity is defined as : $D' = (A\Delta f)^{\frac{1}{2}} D$... (19'39)
 where A = area of detector ; m^2 , and Δf = noise equivalent of bandwidth : Hz.

$$\therefore D' = (A\Delta f)^{\frac{1}{2}} \frac{E_o}{WE_N} \quad \dots(19'40)$$

The units of D' are usually $(m)(Hz)^{\frac{1}{2}} (W)^{-1}$

Figs. 19'30 and 19'31 illustrate the performance of several photoconductive detectors over a

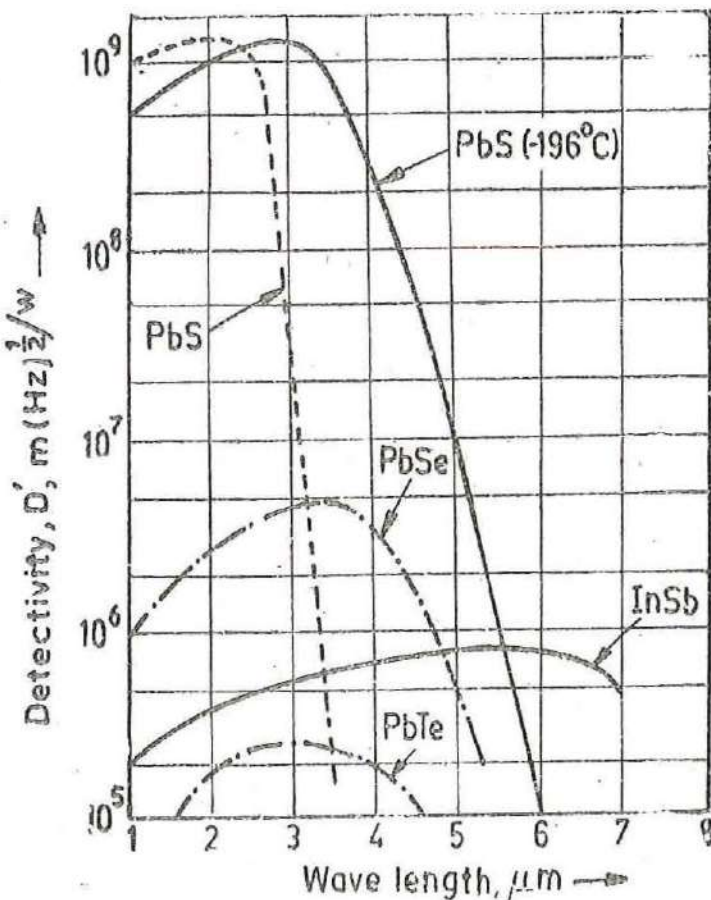

Fig. 19'30. Absolute spectral response of typical photoresistive detectors at room temperature.

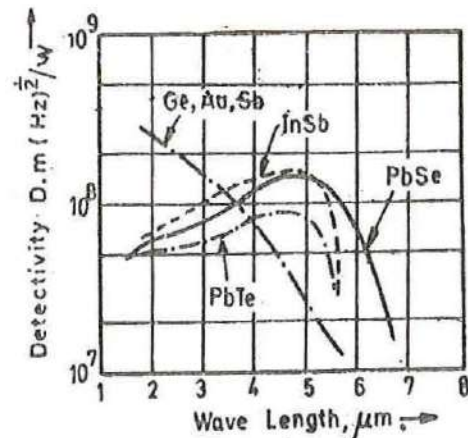

Fig. 19'31. Absolute spectral response of typical photoresistive detectors cooled to liquid nitrogen temperatures.

range of wavelengths. For these figures D' is a monochromatic detectivity for an incident radiation, which is chopped at 900 Hz and has a 1 Hz waveband.

The lead sulphide (PbS) cell is very widely used for detection of thermal radiation in the wavelength band of 1 to 3 μm . By cooling the detector, a much better response in the higher wavelengths of 4 or 5 μm can be had. Indium antimonide (In Sb) is preferred for longer wavelengths.

19'29. Photovoltaic Cell. This is an important class of photodetectors. They generate a voltage which is proportional to EM radiation intensity. They are called photovoltaic cells because of their voltage generating characteristics. They in fact convert the EM energy into electrical energy. They are passive transducers, *i.e.*, they do not need an external source to power them.

A photovoltaic cell is shown in Fig. 19'32. The cell is a giant diode, constructing a *pn* junction between appropriately doped semiconductors. Photons striking the cell pass through the thin *p*-doped upper layer and are absorbed by electrons in the lower *n* layer, causing formation of conduction electrons and holes. The depletion zone potential of the *pn* junction then separates these conduction holes and electrons causing a difference of potential to develop across the junction.

The open circuit voltage is given by : $E_o = E_o \log_e I$ volt ...(19'41)
 where E_o = calibration voltage ; V, and I = intensity ; W/m^2 .

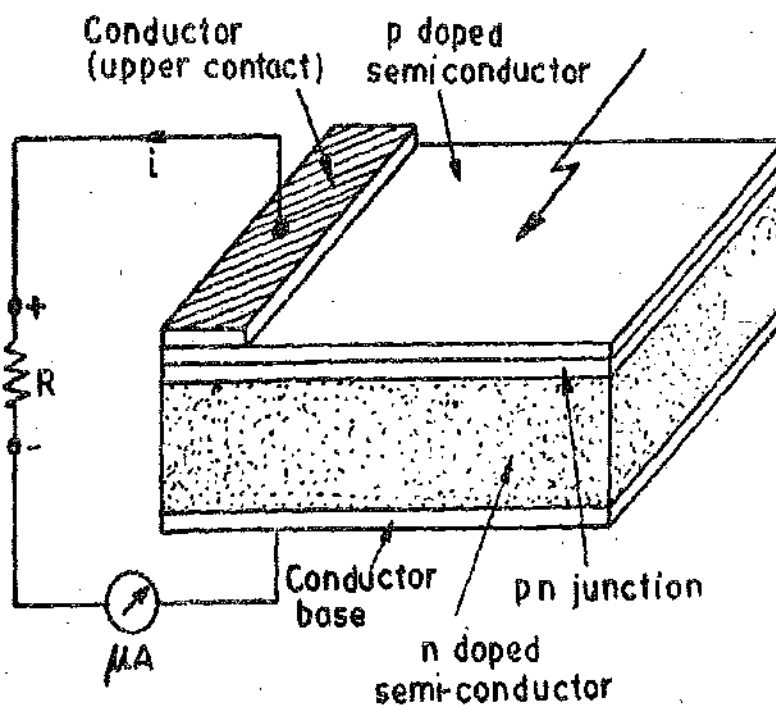

Fig. 19'32. Photovoltaic cell.

All photovoltaic cells have low but finite internal resistance. When connected in a circuit having some load resistance, the cell voltage is reduced somewhat from the value given by Eqn. 19'41. Fig. 19'33 shows the current versus luminous flux characteristics of a typical photovoltaic cell. These characteristics show that the current is a function of the cell incident luminous flux, and hence microammeter shown in Fig. 19'32 may be directly calibrated to read luminous flux or luminous intensity or illuminance.

The photovoltaic cells can operate satisfactorily in the temperature range of -100 to 125°C . The temperature changes have little effect on short-circuit current but affect the open circuit voltage considerably. These changes may be of the order of a few $\text{mV}/^\circ\text{C}$ in output voltage. Table 19'3 gives the list of some typical materials used for photovoltaic cells. It is clear from Table 19'3 that the response of these cells is very fast and therefore photovoltaic cells are widely used in light exposure meter in photographic work.

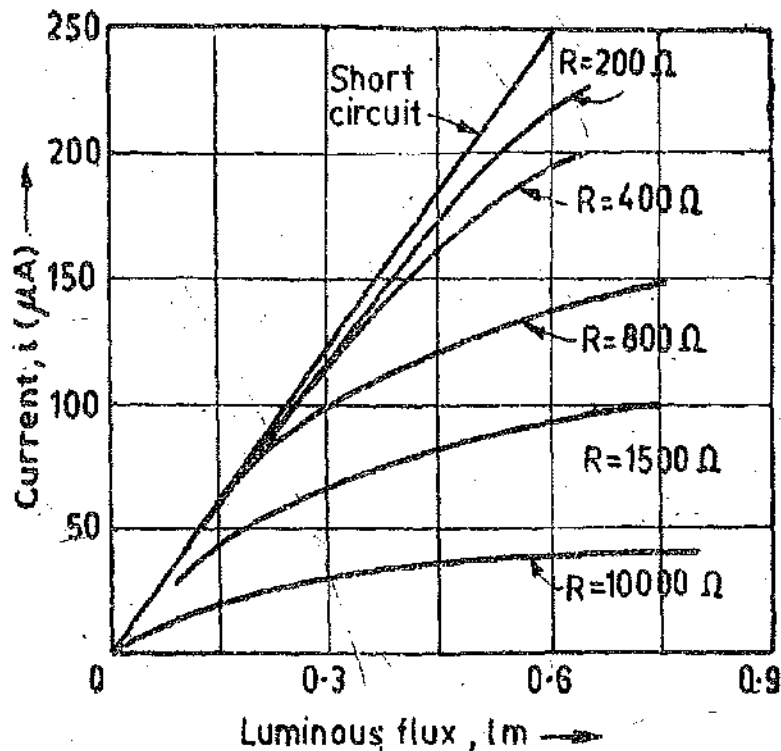

Fig. 19'33. Current versus luminous flux characteristics for a photovoltaic cell.

TABLE 19'3

Typical Photovoltaic Cell Characteristics

Cell Material	Time Constant	Spectral Band
Silicon (Si)	20 μ s	0.44 μ m – 1 μ m
Selenium (Se)	2 ms	0.3 μ m – 0.62 μ m
Germanium (Ge)	50 μ s	0.79 μ m – 1.8 μ m
Indium Arsenide (InAs)	1 μ s	1.5 μ m – 3.6 μ m (cooled)
Indium Antimonide (InSb)	10 μ s	2.3 μ m – 7 μ m (cooled)

Example 19'15. A CDS cell has a dark resistance of 100 k Ω and a resistance in a day light beam of 30 k Ω . The cell time constant is 72 ms. Find the resistance of cell after 10 ms of application of beam.

Solution. From Eqn. 19'35, the resistance of cell is :

$$R_t = R_i + (R_f - R_i) \left(1 - e^{-t/\tau} \right) = 30 + (100 - 30) \left(1 - e^{-10/72} \right) \text{ k}\Omega = 39 \text{ k}\Omega.$$

Example 19'16. The effective area of a photodiode is $0.2 \times 10^{-6} \text{ m}^2$ and irradiance is 250 W/m². Calculate the incident power. If the load resistance is 10 k Ω and the capacitance of the diode is 2 pF, find out the cutoff frequency.

Solution. Incident power $W = 250 \times 0.2 \times 10^{-6} = 50 \times 10^{-6} \text{ W} = 50 \mu\text{W}$.

$$\text{Cutoff frequency } f_c = \frac{1}{2\pi RC} = \frac{1}{2\pi \times 10 \times 10^3 \times 2 \times 10^{-12}} \approx 8 \times 10^6 \text{ Hz} = 8 \text{ MHz}.$$

Example 19.17. Calculate the incident radiation at $5 \mu\text{m}$ that is necessary to produce a signal to noise ratio of 45 db with an indium antimonide detector at room temperature having an area of 4 mm^2 . The detectivity is $10^8 \text{ m (Hz)}^{1/2}/\text{W}$ at $\Delta f = 1 \text{ Hz}$.

Solution. We have signal to noise ratio as 45 db.

$$\text{or } 20 \log \frac{E_0}{E_N} = 45 \quad \therefore \frac{E_0}{E_N} = 177.8$$

$$\text{From Eqn. 19.40, } D' = (A \Delta f)^{1/2} \frac{E_0}{W E_N}$$

$$\therefore \text{ Incident power } W = (A \Delta f)^{1/2} \frac{E_0}{E_N} \cdot \frac{1}{D'} = (4 \times 10^{-6} \times 1)^{1/2} \times 177.8 \times \frac{1}{10^8} = 2 \times 10^{-9} \text{ W.}$$

Example 19.18. A photovoltaic cell produces a voltage of 0.33 V on open circuit when illuminated by 10 W/m^2 radiation intensity. A current of 2.2 mA is delivered into a 100Ω load at that intensity. Calculate : (a) the internal resistance, and (b) the open circuit voltage at 25 W/m^2 .

Solution. (a) Let R_{in} and R_L be the internal and load resistance respectively.

$$\therefore i = \frac{V}{R_{in} + R_L} \quad \text{or } 2.2 \times 10^{-3} = \frac{0.33}{R_{in} + 100}$$

$$\therefore \text{ Internal resistance } R_{in} = 50 \Omega.$$

$$(b) \text{ From Eqn. 19.42 : Calibration voltage } E_0 = \frac{E_0}{\log_e I} = \frac{0.33}{\log_e 10} = 0.143 \text{ V}$$

$$\therefore \text{ Open circuit voltage at } 25 \text{ W/m}^2, E_0 = 0.143 \log_e 25 = 0.46 \text{ V.}$$

Example 19.19. The characteristics of a certain photovoltaic cell are given in Fig. 19.33. The cell is placed 0.914 m from a lamp of 180 cd intensity. The window area is 1935 mm^2 . Find the current when a meter of 800Ω resistance is connected across the cell.

$$\text{Solution. Solid angle } \Omega = \frac{A}{r^2} = \frac{1935 \times 10^{-6}}{(0.914)^2} = 2.3 \times 10^{-3} \text{ sr.}$$

$$\text{Luminous Flux } F = I \Omega = 180 \times 2.3 \times 10^{-3} \text{ lm} = 0.417 \text{ lm.}$$

From Fig. 19.33 corresponding to a luminous flux of 0.417 lm and a resistance of 800Ω , the current is $120 \mu\text{A}$.

19.30. Photocells in Physical Photometry. In physical photometry a photosensitive cell of the type most suited to the particular quantity under measurement and the precision with which it is to be measured takes the place of the photometer head. Where utmost precision is required, as in the laboratory, and where a complex circuit is not a disadvantage, then photoemissive cell is the best type because of its stability. When used correctly, the current in a photoemissive cell is proportional to the illuminance.

The photovoltaic cell, because of its simplicity, is best suited for portable instruments for which the high precision of a laboratory method is not expected. It is particularly suited to the illumination survey of a large area because of its flat surface. In this connection it is essential to take account of an error which may be introduced, as is clear, the if angle of incidence varies during measurement. If the sensitive area is A , then this will be the area when the incidence-of-light is normal to the surface.

When the angle of incidence is θ , the projected area will be $A \cos \theta$. Thus for constant illuminance, the current should be proportional to $\cos \theta$ but this, in fact, is not the case. The reading is correct for angles up to about 50° to 60° ; but beyond this an error is introduced which, for an incidence of 75° , may be as high as 40% and is greater for greater angles of incidence. Thus for such measurements the cell should be calibrated for varying incidence or instead the cell should be "COSINE CORRECTED". This may be done by placing a thin opal translucent disc over the sensitive surface.

Photovoltaic cell is also a very convenient instrument for measurement of illuminances of the order found in factories, or in street lighting. The micro-ammeter connected to the cell may be calibrated in terms lx directly. The connection between micro-ammeter and the cell is made through a thin twin cable. This enables the cell to be placed in the correct position while the micro-ammeter

can be so far away that there is no danger of the observer obstructing the area under observation. The micro-ammeter may be provided with shunts in order to read various levels of illuminance.

19.31. Measurement of Luminance. The photocells can be used for the measurement of luminance of an illuminated surface. The photocell is provided with a directional baffle which receives the luminous flux from a convenient solid angle. The instrument is then calibrated in terms of luminance units.

Suppose the area of baffle is A and the luminance is L and therefore the intensity in a normal direction is $I = LA$. As there is practically no lower limit to the illuminance on the target of a photocell for which an accurate measurement can be made. Luminance determination can be made on a photometric bench. The distance of the exposed area from the photocell being such, in relation to its dimensions, the inverse square law can be applied. The measurement of luminance is in fact a measurement of luminous intensity wherein the comparison is made with a standard lamp. If the colour of the surface is different from the colour appearance of standard lamp, then a correction factor has to be applied or a filter of known transmission factor be interposed between the standard lamp and the photocell.

UNSOLVED PROBLEMS

1. The frequency of a given electro magnetic radiation is 6×10^{14} Hz. Find the wavelength. Does this radiation fall within visible spectrum? [Ans. $0.5 \mu\text{m}$; yes]

2. The relative efficacy of radiation of a wavelength of $0.49 \mu\text{m}$ is approximately 0.2. The international luminosity curve indicates relative efficacy of a wavelength of $0.555 \mu\text{m}$ as unity. Radiation equivalent to 20 W is produced by a wavelength of $0.49 \mu\text{m}$. Find out the radiation (in W) at a wavelength $0.555 \mu\text{m}$ which will produce the same sensation in the human eye. [Ans. 4 W]

3. A metal filament gas lamp takes 0.42 A from a 230 V supply and emits 1120 lm. Calculate (a) the lumen per watt, (b) the mean spherical luminous intensity (m.s.l.i.) of the lamp, and (c) the m.s.l.i. per watt. [Ans. (a) 11.6 lm/W, (b) 89.2 cd, (c) 0.923 cd/W]

4. The length of a fluorescent coating of a certain fluorescent lamp is 1460 mm and the diameter is 38 mm. If the luminous intensity in a radial direction is 340 cd, what is the luminance of the lamp? [Ans. 6130 cd/m²]

5. A lamp giving 200 cd in all directions below the horizontal plane is suspended 2 m above the centre of a square table 1 m side. Calculate the maximum and minimum illuminances on the surface of the table. [Ans. 50 lx, 41.9 lx]

6. A 200 cd lamp emits light uniformly in all directions and is suspended 5 m above the centre of a working plane which is 7 m square. Calculate the illuminance immediately below the lamp and also at each corner of the square. If the lamp is fitted with a reflector which distributes 60% of the light emitted uniformly over a circular area 5 m in diameter, calculate the illuminance over this area. [Ans. 8 lx, 2.87 lx; 76.8 lx]

7. Four lamps are suspended 8 m above the ground at the corners of a square 4 m side. Each lamp gives 250 cd uniformly below the horizontal plane. Calculate the illuminance (a) on the ground directly under each lamp, (b) at the centre of the square. [Ans. 11.6 lx]

8. Two lamps of 16 cd and 24 cd are respectively 2 m apart. A screen is placed between them 0.8 m from 16 cd lamp. Calculate the illuminance on each side of the screen. Where must the screen be placed in order to be equally illuminated from both the sides? [Ans. 25 lx, 16.67 lx, 0.9 m from 16 cd source]

9. A certain lamp gave the following distribution of luminous intensity, in a vertical plane, the angle being measured from the axis through the centre of lamp cap.

Angle degree	0	15	30	45	60	90	120	150	165	180
Intensity, cd	0	84	154	200	224	254	266	276	283	288

Find: (a) the mean spherical luminous intensity, and (b) the luminous flux of the lamp. [Ans. 236 cd; 2960 lm]

10. A 200 W tungsten lamp has a luminous efficacy of 18.3 lm/W. Calculate the luminous intensity. [Ans. 46×10^3 cd]

11. A detector will just respond to an illumination of 0.14 lux. Find the maximum distance from 10 W tungsten bulb for detectability. The luminous efficacy of a 10 W tungsten lamp is 7.8 lm/W.

12. A photomultiplier has a current gain of 3×10^6 . A weak light beam produces 50 electrons per second at the photocathode. What anode to ground resistance must be used to get a voltage of 3 μV ? $1 e = 1.6 \times 10^{-19}$ C. [Ans. 125 k Ω]

13. Germanium has a band gap of 0.67 eV. Find the maximum wavelength for resistance change by photon absorption. Planck's constant = 6.63×10^{-34} Js and $1 \text{ eV} = 1.6 \times 10^{-19}$ J. [Ans. 1.86 μm]

14. A lead sulphide detector is noted to sense radiant energy at 2 μm . What incident flux on a 1 mm² detector at room temperature is necessary to produce a signal to noise ratio of 40 db. The detectivity is 1.5×10^9 m (Hz)^{1/2}/W at $\Delta f = 1$ Hz. [Ans. 0.067×10^{-9} W]

15. A lead-sulphide detector is used to measure a radiation signal at 3.5 μm . What reduction in incident power, measured in decible, is afforded when the detector is cooled to -196°C , assuming a constant S/N ratio. The detectivities at room temperature and -196°C are 1×10^8 and 1×10^9 m (Hz)^{1/2}/W respectively. [Ans. 60 db]

Electronic Instruments

20'1. Electronic Voltmeters. Electronic voltmeters use rectifiers, amplifiers and other circuits to generate a current proportional to the voltage being measured. The current so produced is measured by a permanent magnet moving coil instrument (PMMC or d'Arsonval movement) having taut band suspension.

20'2. Advantages of Electronic Voltmeters. Almost all electronic voltmeters make use of the rectifying properties of diodes whether vacuum tube or metal rectifiers or semi-conductor diodes. Vacuum tube diode was first used in an electronic voltmeter in 1895 and is still quite popular as a sensing element of vacuum tube voltmeters (VTVM). In some other applications vacuum tube triodes or transistors are used.

The advantages of electronic devices for measurement purposes are :

1. Low Power Consumption. A PMMC voltmeter when connected to a circuit draws a large current from the circuit under test, that is, it drains a large power from the test circuit. For most electrical circuits, this draw of current or power consumption is too small to make much difference. For example a 20,000 Ω/V meter draws only 50 μA for full scale deflection. But the currents involved in certain electronic circuits may be very small and even 50 μA current may load the circuit to a considerable extent.

Electronic voltmeters utilize the amplifying properties of vacuum tubes and transistors and therefore the power required for operating the deflecting element of PMMC instrument can be supplied from an auxiliary source. Thus, while the circuit whose voltage is being measured controls the sensing element of the voltmeter, the power drawn from the circuit under measurement is very small or even negligible. This can be interpreted as that the voltmeter circuit has a very high input impedance. This feature of electronic voltmeters is indispensable for voltage measurements in many high impedance circuits such as encountered in communication equipment.

2. Detection of Low Level Signals. The permanent magnet moving coil voltmeter is not suitable for the measurement of very small voltages. For example a 100 V, 20,000 Ω/V PMMC voltmeter may have hundred scale divisions. Thus an input voltage of 1V will deflect the pointer by one division on the scale. But in electronic circuits we may have to measure voltages of the order of microvolt. Obviously, the pointer deflection of an ordinary PMMC voltmeter for such voltages would be virtually impossible to detect. Therefore a more sensitive voltmeter is needed for such applications.

In electronic voltmeters the amplifying properties of vacuum tubes and transistors are utilized to detect and measure low voltages which may otherwise be impossible to measure by conventional instruments.

3. High Frequency Range. The most important feature of electronic voltmeters is that their response can be made practically independent of frequency within extremely wide limits. Some electronic voltmeters permit the measurement of voltage from direct current to frequencies of the order of hundreds of MHz. The high frequency range may also be attributed to low input capacitance of most electronic devices. The capacitance may be of the order of a few pF.

20'3. Vacuum Tube Voltmeters (VTVMs). Vacuum tube voltmeters may be considered as one of today's most useful instruments for the measurement of a.c. and d.c. voltages.

The practical vacuum tube voltmeter (VTVM) circuits fall into the following categories :

(1) Diode type, (2) Single triode type, (3) Balanced triode type, (4) Rectifiers amplifier type, and (5) Amplifier-rectifier type.

In addition to above, many other forms of vacuum tube voltmeters have been devised. These include arrangements employing slide back vacuum tube voltmeters and vacuum tube voltmeters which use logarithmic characteristics.

20.4. Average reading Diode Vacuum Tube Voltmeters. The simplest type of diode voltmeter is similar to a rectifier instrument. Fig. 20.1 (a) shows a schematic diagram for an average reading voltmeter using a vacuum tube diode. The arrangement includes a vacuum tube diode, a resistance R and a PMMC instrument, all connected in series.

A high series resistance R is desirable both to limit the current and to make the plate voltage-current characteristics linear. A linear plate characteristics are essential in order to make the current directly proportional to voltage. The plate resistance of a diode is not constant and hence in order to swamp out the variations in plate resistance, a high value of series resistance, R is used. If the series resistance is sufficiently high, the resistance of the tube is negligible in comparison, and therefore we get a linear plate voltage-current characteristics thereby the scale of PMMC instrument is uniform and is independent of the variations of tube resistance. A series resistance of $10^6 \Omega$ or more is used for the purpose for a sinusoidal input voltage as shown in Fig. 20.1 (b).

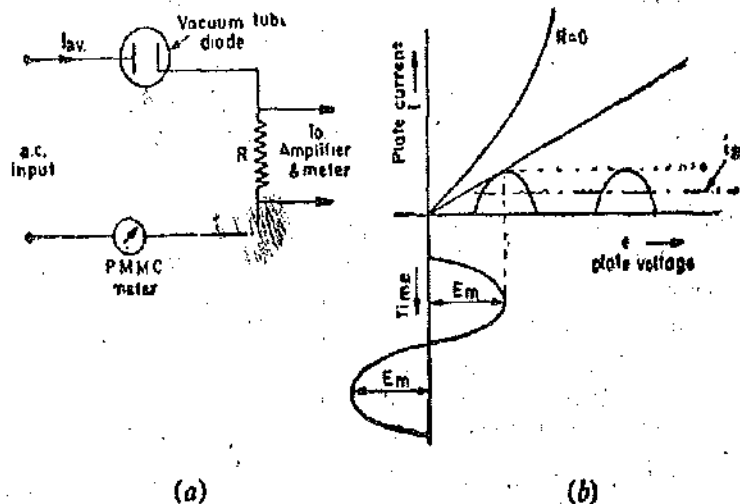

Fig. 20.1. Average reading vacuum tube diode voltmeter.

The diode conducts during the positive half cycle and does not conduct during the negative half cycle, the average current through the meter is thus :

$$I_{av} = \frac{E_{av}}{2R} = \frac{E_{rms}}{2 \times 1.11 \times R} = 0.45 \frac{E_{rms}}{R} \quad \dots(20.1)$$

and E_{rms} are respectively, where; E_{av} average and rms values of applied voltage.

The factor 2 is introduced because the voltmeter works on half wave rectification

Advantages. The average reading diode voltmeter has many advantages :

1. **Simplicity.** The average reading diode type meter is simplest in construction.

2. **High input resistance and low power consumption.** The input resistance of the circuit depends upon the value of resistance, R which ranges from $10^6 \Omega$ to $1 \text{ M}\Omega$, and thus resistance is higher than that of multimeter circuits for a.c. voltage measurements. In most diode voltmeters, indication is obtained from the output of d.c. amplifier, the input of which is connected across the resistance R . This makes it possible to replace the relatively sensitive meter by a less sensitive and rugged meter. Also the input resistance, R can be made greatly large say of the order of tens to hundred of $\text{M}\Omega$. This way the power consumed by the voltmeter can be made negligibly small. (This is because the power consumed by the diode circuit is $E_{rms}^2/2R$ watt).

3. **Conversion to rms reading Voltmeter.** The rms value of voltage is usually of principle interest. The average reading voltmeter can be converted into an rms reading voltmeter by calibrating the meter scale in terms of the rms value of a sine wave. Since so many waveforms in electronics are sinusoidal, the average reading voltmeter with an rms calibrated scale is an entirely satisfactory instrument. In fact an average reading voltmeter with a calibrated rms scale is much less expensive than a true rms reading voltmeter.

The rms value of a voltage wave which has similar positive and negative half cycles, is related to the average value by the form factor. For a sinusoidal voltage the form factor is 1.11. Therefore, when an average reading voltmeter has scale markings corresponding to the rms value of the applied sinusoidal input waveform, those markings are actually corrected by a factor 1.11 from the average value of applied voltage. Non-sinusoidal waveforms, when applied to this voltmeter, will cause it to read either high or low, depending upon the form factor of the waveform. If the form factor of the applied voltage is less than that of a sinusoidal wave (i.e., less than 1.11), the meter reading is high, while on the other hand if the form factor of the applied voltage is higher than 1.11, the meter readings are lower.

It should be understood that this instrument can be used to indicate d.c. voltages. Since for d.c. the diode conducts all the time, the scale markings of the instrument will have to be multiplied by $2 \times 1.11 = 2.22$ for d.c.

Disadvantages :

1. **Frequency range.** The frequency range of this instrument extends well over the audio-frequency range, but at radio frequencies the valve capacitance and the distributed capacitance of the series resistance, R , upset the voltage division and make the instrument useless.

2. **Response to low voltages.** The instrument gives a deflection proportional to the mean value during the conducting half cycle provided it is not used for voltages comparable with the voltage drop across the valve. The instrument has an evenly divided scale because of linear characteristics for higher voltages but exhibits non-linearity for lower voltages and therefore for lower voltages, a graphical treatment may have to be used to determine the voltage.

Example 19.1. A symmetrical square-wave voltage is applied to an average reading diode voltmeter having a scale calibrated in terms of rms values of a sine wave. Calculate the error in meter indication.

Solution. The deflection of the instrument depends upon the average value of current. The form factor of a sinusoidal wave is 1.11 and therefore average value of current fed to the meter for sinusoidal voltage supply is :

$$I_{av} = \frac{E_{av}}{2R} = \frac{E_{rms}}{2 \times 1.11 \times R} = 0.45 \frac{E_{rms}}{R}$$

The form factor of a square wave is 1 and with half wave rectification, the average value of current with square wave is :

$$I_{av} = \frac{E_{av}}{2R} = \frac{E_{rms}}{2 \times 1 \times R} = 0.5 \frac{E_{rms}}{R}$$

Thus the average current with square wave is higher than that with sinusoidal waveform and hence the meter will read high with square wave.

$$\text{Percentage error} = \frac{0.5 - 0.45}{0.45} \times 100 = 11.1\% \text{ high}$$

20.5. **Peak reading Diode Vacuum Tube Voltmeters.** The most common of the many vacuum tube arrangements that are used as vacuum tube voltmeters is the diode peak-reading voltmeter. For peak reading vacuum tube voltmeters, four types of common arrangements are used.

- (i) Series type. (ii) Shunt type. (iii) Compensated shunt type. and (iv) Slide back type.

1. Series type. The series type of arrangement is shown in Fig. 20'2 (a).

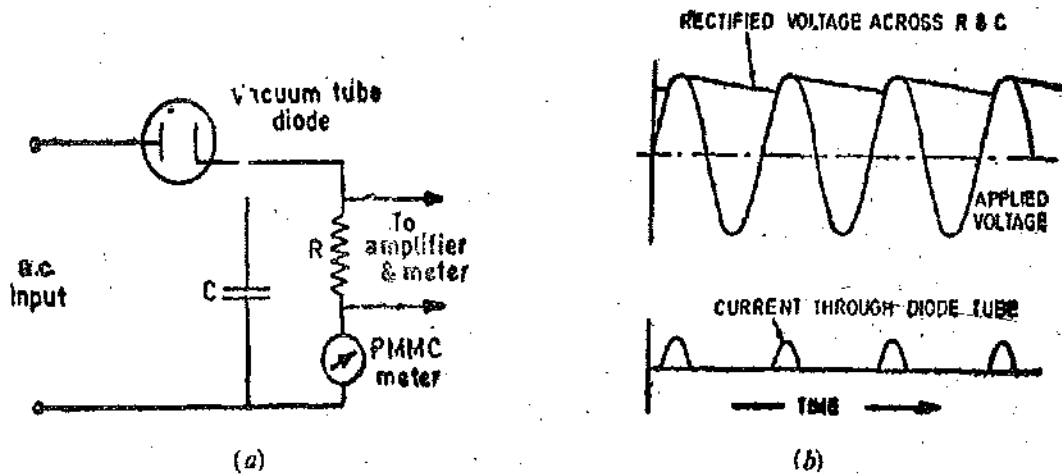

Fig. 20'2. Series type peak reading diode vacuum tube voltmeter.

The series type peak reading voltmeter is an ordinary detector employing high load resistance R and a PMMC instrument (say a micro-ammeter) connected in series. The principle of operation is shown in Fig. 20'2 (b). At each positive peak of the applied input voltage, the capacitor C is charged to a potential that is equal to the peak voltage. Between peaks a small portion of the charge on the capacitor leaks off through the resistance R , causing a small fall in the capacitor voltage. At the positive peak of the next cycle the charge that has been lost in this way is replenished (given back) by a pulse or current through the diode. The voltage across capacitor C , and hence across the resistance R , is thereby again built up almost to the peak of the applied voltage. Either the average voltage across R or the average current through R , can be used to indicate the peak of the applied voltage. When the applied (input) voltage is not too small, the relationship between peak voltage and the rectified output is linear.

When the meter is connected as shown in Fig. 20'2 (a), the current through the meter can be used to indicate peak applied voltage. However, the voltage across resistance R can be amplified by a d.c. amplifier and by using a PMMC instrument across the amplifier output the peak voltage can be indicated. The latter arrangement is preferable as explained earlier on account of the fact that the resistance R can be made very high, thereby reducing the power consumption and also that a less sensitive type of PMMC type of instrument could be used. The high value input resistance also results in more linear relationship between peak applied voltage and the meter indication. Also the performance of the diode with inputs consisting of pulses and modulated waves is improved.

The d.c. amplifier associated with the diode rectifier should be provided with stabilizing means to prevent drift in the indication of the output meter. In general a voltage regulated power supply combined with a compensating circuit is used.

The use of high resistance R , associated with a d.c. amplifier, no doubt results in a high input resistance but all the same it implies that an applied voltage of sufficient amplitude is required so that the system acts as a peak voltage device. The greatest disadvantages of this system is with regards to measurement of low voltages. If the applied voltage is too small, then some current flows throughout the cycle of the voltage as a result of the high velocity of emission of electrons, and the input resistance may be a few hundred ohm and this defeats the very purpose of using electronic instruments.

2. Compensated shunt type. The operation of shunt type and compensated shunt type VTVMs are similar to that of series type. These meters are used when it is neither possible nor desirable to have circuit under measurement as the return path for the voltmeter. Diode tubes have a characteristic which is referred to as a contact potential effect. This effect is caused by electrons striking the plate with sufficient velocity to give the plate a negative potential whenever the tube filament or heater circuit is in operation. The negative potential results in a steady deflection of the PMMC indicating meter on account of the electron emission current even in the absence of any applied voltage. Thus the meter shows some deflection even if there is no voltage applied to it. This has to be compensated for so that the instrument can be set to zero when there is no voltage applied to the VTVM. Fig. 20.3 shows the circuit for a compensated shunt type of peak reading diode VTVM.

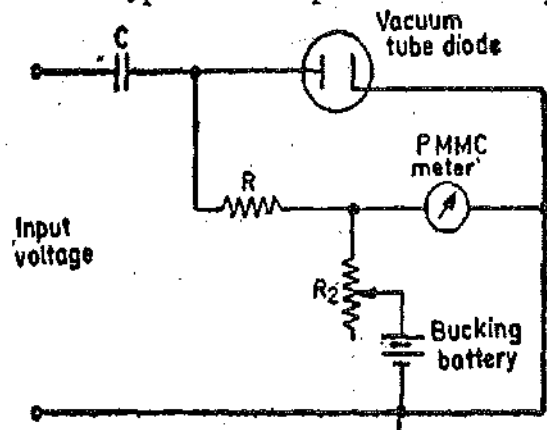

Fig. 20.3. Compensated shunt type diode peak reading voltmeter.

The compensating circuit consists of a variable resistance R_2 and a bucking battery. The battery provides a "bucking voltage". In the absence of any applied voltage, the resistance R_2 is adjusted so that the meter reads zero. Thus this compensating circuit is in fact a "zero setting" arrangement. The resistance R_2 must have a value greater than that of the meter in order to prevent the path formed by resistance R_2 and the battery forming a low impedance path for strong signals.

20.6. Triode Vacuum Tube Voltmeters. Triode vacuum tube voltmeters offer advantages over the diode type. These advantages are :

1. The input to triode is through its grid and thus the input impedance of a triode circuit is quite high on this account.
2. The power drawn for the operation of a triode is not drawn from the circuit under measurement but from an auxiliary source.
3. A triode is an amplifier and therefore intrinsic properties of triode can be utilized to amplify a low level signal for measurement purposes.
4. Since the input to a triode is fed to the grid circuit, the indicating meter is completely isolated from the input circuit.

20.7. Balanced Bridge Triode Vacuum Tube Voltmeter. The balanced bridge triode vacuum tube voltmeter is an extremely popular type of meter. This instrument is used to overcome certain inherent disadvantages of instruments using a single triode tube. This instrument can be used to measure both a.c. and d.c. voltages and when provided with additional circuitry can be used to measure resistance. This makes the instrument really versatile for laboratory purposes.

Fig. 20.4 shows the basic circuit for a balanced bridge triode VTVM. This instrument uses two identical triode tubes V_1 and V_2 which may be contained in a single envelope. Plate voltage is applied to the two triodes through a network consisting of resistances R_1 , R_2 and R_3 . Resistor R_2 is variable, and when properly adjusted, the voltages on the two triodes are equal. Under this condition, since there is no voltage difference between the two plates, the PMMC milliammeter, which is connected between them reads zero. Thus resistor R , is the zero adjusting device for the instrument.

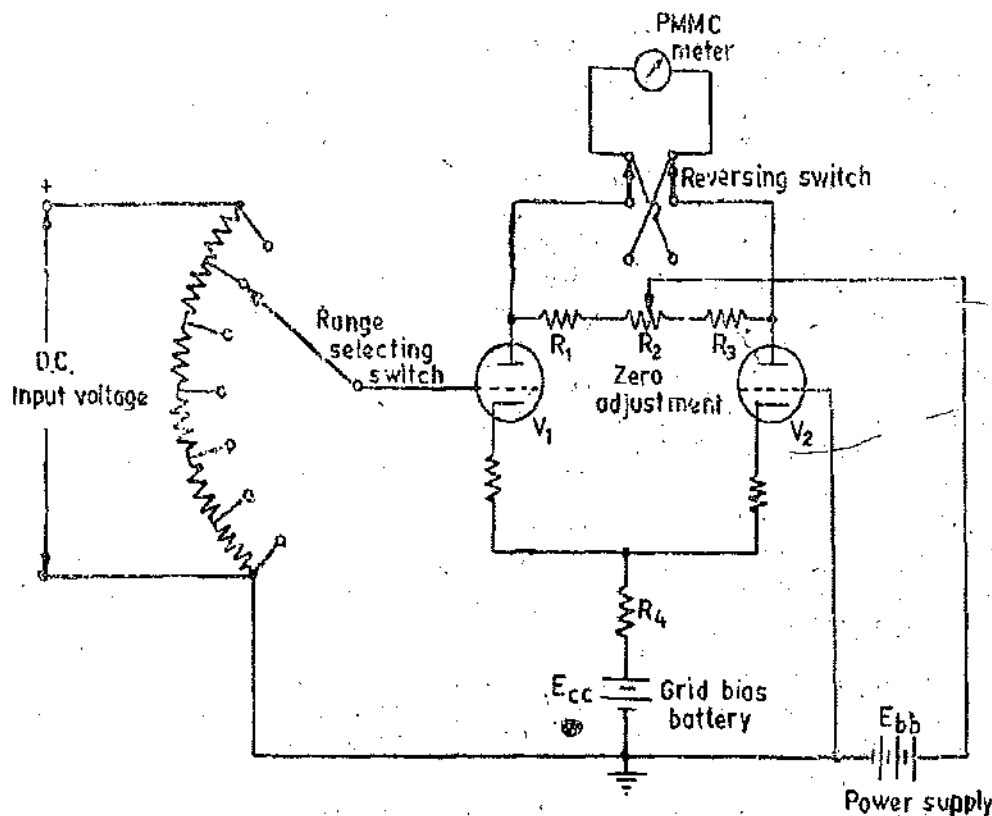

Fig. 20'4. Balanced bridge triode vacuum tube voltmeter.

The bias battery E_{cc} places a positive bias on the cathodes of both tubes. Placing a positive bias on the cathode of a triode is equivalent to placing a negative bias on its grid.

When a d.c. input voltage is applied, a positive voltage is impressed on the grid of triode V_1 and therefore the current flowing through this tube increases causing its plate voltage to decrease. This current also flows through resistor R_4 which is common to both the tubes V_1 and V_2 . An increase in current through R_4 increases the voltage drop across it and therefore cathode of triode V_2 becomes more positive. This increases the negative grid bias of tube V_2 and hence the plate current of triode V_2 is decreased and its plate voltage increases i.e., becomes more positive. Now the plates of the triodes are no longer at the same potential and hence a current flows through the PMMC milliammeter. Since this current is directly proportional to the input d.c. voltage, the PMMC milliammeter can be calibrated to read the input voltage.

When a negative input voltage is applied to the grid of triode V_1 , an opposite action takes place and the potential difference between the two plates is in the opposite direction. Accordingly the meter is reversed by means of a reversing switch. In this way readings of the meter can be taken regardless of the polarity of the input voltage. The range of instrument can be extended by using a potential divider arrangement and a range selector switch.

We have described the operation of the instrument for d.c. input voltages. When a.c. voltages are to be measured, they should be rectified and then applied to the input terminals.

Advantages. The advantages of a balanced bridge triode vacuum tube voltmeter over a vacuum tube voltmeter using a single-triode are :

1. Effects of changes and variations in the tube characteristics are minimised.
2. Fluctuations in the power supply have a smaller effect on the measuring circuit.
3. There is a lesser tendency for the meter zero to shift during the operation of the meter.

Ohm Mode. This VTVM can be used for measurement of resistance of an unknown resistor.

The unknown resistor in series with an internal battery and a new resistance divider network is used only when the function switch is set to Ohm position. The voltage drop across the unknown resistance is applied to the control grid of the input tube. This results in unbalancing of the bridge. The resulting unbalance of the bridge is indicative of the voltage drop across the resistance and hence the magnitude of the resistance.

The simplified circuit diagram for operation of a VTVM in the ohm mode (function) is shown in Fig. 20'5. When the unknown resistance is connected between the ohm and the ground terminals, a current flows through the resistance and the part of the resistance divider network selected by the range switch, on account of the voltage of the internal battery.

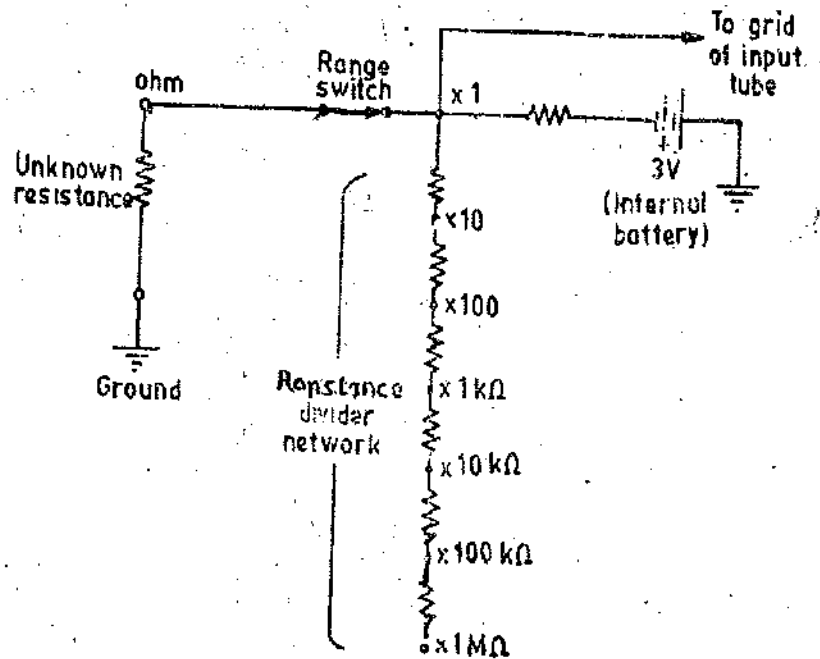

Fig. 20'5. Ohm mode of VTVM.

The voltage drop across the unknown resistance is applied to the input of the bridge circuit, producing an indication of the meter. The meter is calibrated in terms of resistance.

20'8. Electrometer Type VTVM. An electrometer is a highly sensitive instrument for measurement of voltages and currents. This is primarily used for measurement of small voltages. When dealing with small voltages, a difficulty arises: the very small grid current in a conventional vacuum tube triode (which is considered negligible) may prove to be a partial short circuit on a very high resistance circuit whose voltage is to be measured. Therefore, special valves, which draw insignificant grid current have to be used for such purposes.

The grid current in a vacuum tube is due to such causes as leakage over the internal surfaces of the valve, slight emission of electrons from the grid and ionization of residual gas in the tube. Special valves, called *electrometer valves*, have been designed to eliminate the effects mentioned above so that grid current is made as well as possible. An electrometer valve has a usually low grid current say of the order of 10^{-12} A. By way of comparison, a valve used in conventional VTVM may have a grid current 10^4 times as great as in an electrometer valve. To assist in minimizing the residual grid current, a low plate voltage (say about 10 V) is utilised.

For measurement of small d.c. voltages, a d.c. amplifier stabilized by a negative feedback is used. For measurement of a.c. voltages, a probe containing a vacuum tube diode rectifies the a.c. voltage before it is applied to the d.c. amplifier.

20'9. Transistor Voltmeters (TVMs).

Transistor voltmeters (TVMs) have various advantages over the vacuum tube voltmeters (VTVMs).

1. A TVM does not require any warm up time while for a VTVM a warm up time is necessary in order to obtain drift free indications.
2. A TVM is comparatively compact and is light in weight and thus well suited for field work.
3. A TVM may be designed as a battery operated instrument. For field work, an instrument, whose power supply is an internal battery, is necessary. Thus a battery powered TVM is a very popular choice for use in locations where a source of external power is not available. Also.

for measurements in an area that contains troublesome groundloops, a battery powered instrument is to be preferred over a mains powered voltmeter to remove the ground paths.

4. A conventional transistor offers a low input resistance as compared to a vacuum tube and therefore, the earlier TVMs used a hybrid configuration, that is, a combination of vacuum tubes and transistor circuits wherein the vacuum tube formed the input stage of the voltmeter on account of its high input resistance. But the use of a vacuum tube at the input stage negates most of the advantages of an all transistor voltmeter. Thus now hybrid configurations are obsolete. In their place field effect transistors (FET) which offer practically as high input impedance as vacuum tubes are used at the input stage. The gate of a FET, can be compared to grid of a vacuum tube, and hence offers almost an infinite input resistance.

20.10. TVM with Cascaded Transistors. A circuit using a single transistor may be used for the measurement of voltage but such a circuit suffers from a big disadvantage that its sensitivity is low. To offset this, a TVM uses a pair of transistors connected in cascade. A simplified diagram of a TVM using two cascaded transistors is shown in Fig. 20.6. Here the two transistors Q_1 and Q_2 are direct coupled in a complementary configuration (one is a PNP transistor and the other is a NPN transistor). They form a direct coupled amplifier. The advantage of a complementary configuration is that it minimizes the number of circuit components.

The input voltage is applied through a network of resistances. The range switch selects the resistor that is in series with the transistor for the desired voltage range.

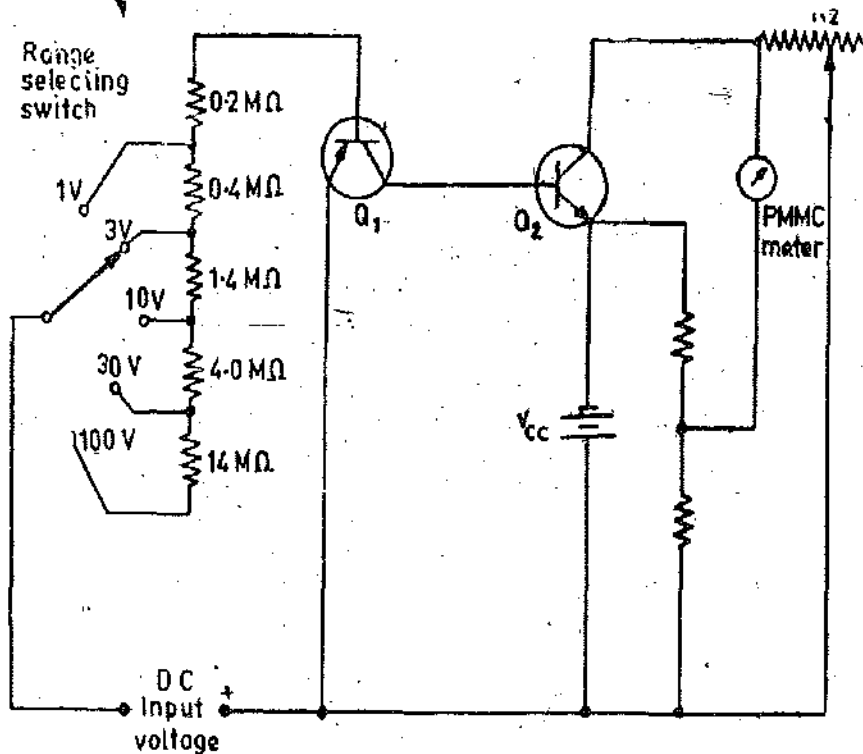

Fig. 20.6. TVM with cascaded transistors.

The values of these resistors are typical. Note that for the 0 to 1 V range, the value of resistance is $200,000 \Omega$. This means that neglecting the small value of resistance offered by transistor Q_1 , the sensitivity is $200,000 \Omega/V$ or $200 \text{ k}\Omega/V$. Thus a current of $1/200,000 \text{ A}$ or $5 \mu\text{A}$, is drawn from the circuit. The values of other resistors are so chosen that the same current ($5 \mu\text{A}$) is drawn at other ranges.

As mentioned above, the sensitivity of this arrangement is $200 \text{ k}\Omega/V$, which is of an order greater than that of a VOM (multimeter), although an ordinary VTVM provides much greater sensitivity on its low voltage range.

Another problem with this TVM is that excessive drift is encountered in operation, and acceptable accuracy can only be obtained at a specific ambient temperature.

Variable resistor R_2 is the zero adjustment resistor that controls the bucking current supplied by V_{cc} to buck out the quiescent current.

20'11. TVMs Using FET as Input Stage. Fig. 20'7 shows a TVM d.c. voltmeter with a field effect transistor (FET) forming the input stage of a direct coupled amplifier. This circuit has the advantage that since a FET (Q_3 shown in Fig. 20'7) has high input impedance, the sensitivity of this meter is high and it does not load the circuit under measurement.

The d.c. input voltage is applied to a range selecting (attenuator) switch. The attenuator is necessary to provide input voltage levels which can be accommodated by the d.c. amplifier.

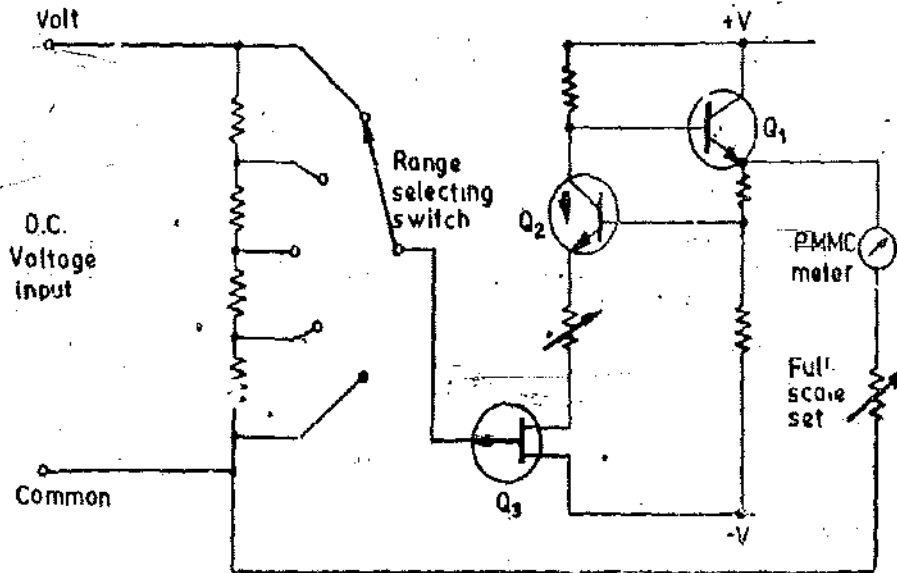

Fig. 20'7. VTM using FET as input stage.

The two transistors Q_1 and Q_2 , form a direct coupled d.c. amplifier driving the meter movement. Provided that the amplifier operates within the limits of its dynamic range, the deflection of the meter is directly proportional to the magnitude of the input applied voltage. The gain of the d.c. amplifier allows the instrument to be used in the mV range. The amplifier has the added advantage that accidental overload voltages do not burn out the meter since the amplifier saturates and thus limits the maximum current through the meter to a safe value. The input impedance of this voltmeter is high enough to make it unnecessary to correct for the loading effect of the circuit under measurement.

Instruments used for micro-volt ranges require a high gain d.c. amplifier in order to supply sufficient current for driving the meter movement. To avoid drift problems usually associated with direct coupled d.c. amplifiers, the "chopper type d.c. amplifier" is normally employed in high sensitivity instruments. In a chopper type d.c. amplifier, the d.c. input is converted into an a.c. voltage, before it is applied to an a.c. amplifier. The amplified a.c. voltage is then converted back into a d.c. voltage.

20'12. Chopper Amplifier Type Voltmeter. A chopper amplifier is normally used for the first stage of amplification in very sensitive instruments of a few μ V range. In such an amplifier the d.c. voltage is chopped to a low frequency, 200 to 300 Hz a.c. It is passed through a blocking capacitor, amplified and then passed through another blocking capacitor in order to remove d.c. drift or offset from the amplified signal. By suitable selection of the blocking capacitors it is possible to manufacture a sensitive d.c. voltmeter which is virtually drift free, has high d.c. input impedance and has high degree of accuracy.

Fig. 20'8 shows the block diagram of chopper type amplifier used in sensitive voltmeters. The arrangement employs photo diodes as nonmechanical choppers for modulation, i.e. conversion from d.c. to a.c. and demodulation, i.e. conversion from a.c. to back to d.c. A photoconductor has a low resistance of the order to a few hundred ohms when it is illuminated by an incandescent or a neon

lamp. Its resistance sharply increases to several megohms, when it is not illuminated. An oscillator drives two neon lamps into illumination on alternate half cycles of oscillation as shown in Fig. 20'3.

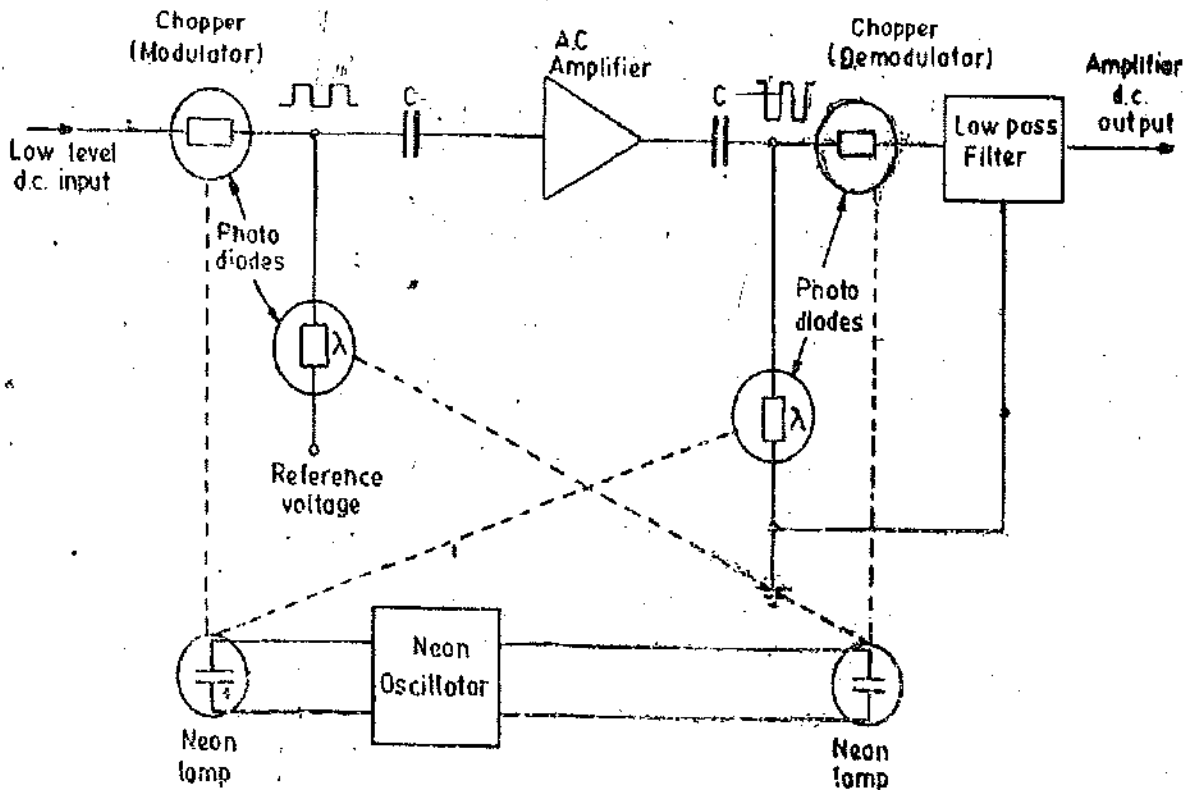

Fig. 20'8. Photoconductive chopper amplifier.

Each neon lamp illuminates one photo-diode in the input circuit of the amplifier and one in the output circuit. The two photodiodes in the input circuit form a series shunt half wave modulator or chopper. Together they act like a switch across the input to the amplifier, alternately opening and closing at a rate determined by the frequency of the neon oscillator.

The input signal to the amplifier is a square wave voltage whose amplitude is proportional to the input voltage level and its frequency is equal to the frequency of oscillator. The a.c. amplifier gives an output square wave with an amplified magnitude. The photodiodes in the amplifier output circuit, operating in antisynchronism with the input chopper, produce a demodulating action giving a d.c. output voltage. This d.c. signal is passed through a low pass filter to remove any residual a.c. components. This amplified drift free d.c. output is then applied to a PMMC movement for measurement. It should be noted that the amplifier is not stabilized by the chopper photodiodes. The chopper only eliminate the necessity for a high gain d.c. amplifier with its inherent drift and stability problems.

The input impedance of chopper amplifier d.c. voltmeter is normally of the order of $10\text{M}\Omega$ or higher, except on very low input ranges. In order to eliminate errors caused by high source impedances, an arrangement for nulling is included in the meter circuit. A control facility provided on the front panel of the instrument permits to null the input voltage with a bucking voltage. When the bucking voltage is equal to the input voltage a null is indicated and the meter exhibits an infinite impedance and therefore the loading effects are totally eliminated. The input voltage is then removed, and the bucking voltage which is equal to the input voltage is indicated by the meter.

A commercially available instrument using a photo chopper amplifier has an input impedance of $100\text{M}\Omega$, a resolution of $0.1\ \mu\text{V}$ and input ranges from $3\ \mu\text{V}$ full scale to $1\ \text{kV}$ full scale with an accuracy of $\pm 2\%$ of full scale deflection.

20'13. Balanced Bridge TVM. A basic configuration of a balanced bridge TVM is shown in Fig. 20'9. This circuit is similar to its counterpart, *i.e.* balanced bridge VTVM shown in Fig. 20'4. The bridge arms consist of resistances R_{01} , R_{02} and the internal collector resistances of transistors

Q_1 and Q_2 . If a positive voltage is applied to the base of Q_1 , an increased emitter current flows. In turn Q_2 draws decreased emitter current due to increased voltage drop across resistance R_1 . Thus, the bridge is unbalanced and a current proportional to the input voltage flows through the meter which can be calibrated to read the voltage directly.

Advantages. Transistor bridge circuits provide stability in TVM operation in the same way as vacuum tube bridge circuits provide stability in VTVM.

A TVM bridge circuit with a substantial negative feedback minimizes drift due to variations in beta (β), I_{co} , and power supply fluctuations. These aspects are explained in detail below :

If the ambient temperature increases, the beta value of both Q_1 and Q_2 increases. Assuming that the two transistors Q_1 and Q_2 are perfectly matched, the increase in current through R_{O1} is the same as through R_{O2} , and the bridge thus remains balanced. As the temperature increases, the saturation current, I_{co} , through each transistor will also increase by the same amount, and the bridge remains balanced.

Power supply fluctuations result in variations V_{CO} and V_{EE} values, and since bias change is the same for both transistors and hence the bridge remains balanced.

The maintenance of calibration accuracy, however, requires the action of a substantial amount of negative feedback, in addition to a stable balance condition.

Let us suppose that resistances R_{B1} , R_{B2} , R_1 and R_2 are replaced by short circuits. The TVM remains operative, provided the value of V_{EE} is properly chosen. Now, if the ambient temperature increases, the β value of Q_1 and Q_2 increases.

When a positive voltage is applied to the base of Q_1 , its collector current becomes greater than what it was at the original temperature and the meter reads high. Note that transistor Q_2 is effective merely to maintain quiescent balance because R_1 is replaced by a short circuit. Thus, it becomes clear that some compensating action, such as a negative feedback, has to be employed to maintain accuracy of calibration.

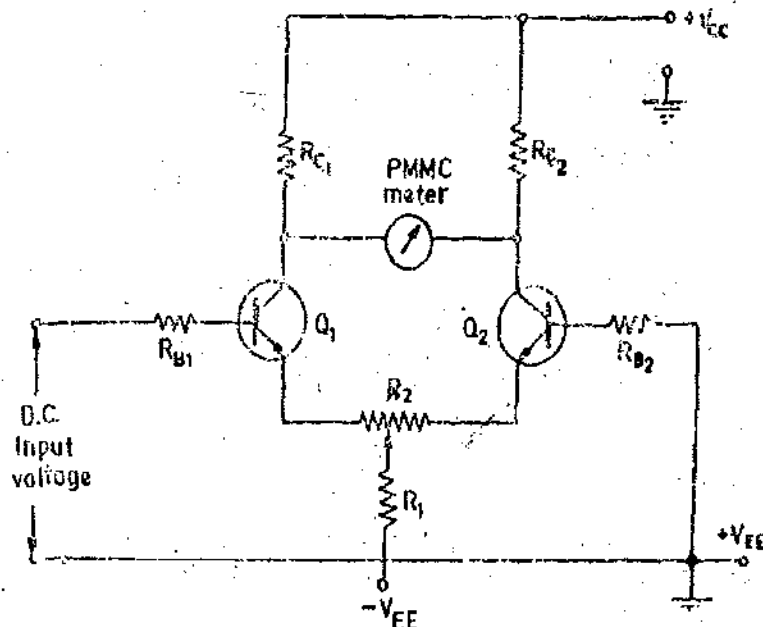

Fig. 20'9. Balanced bridge TVM.

The zero setting resistor, R_2 , also provides resistance in series with the emitters of Q_1 and Q_2 . If the ambient temperature increases, Q_1 and Q_2 draw more emitter current, but the increase in current is limited to some extent by the increased voltage drop across the emitter resistance. The negative feedback is supplemented by the action of resistor R_1 , which has normally a high value. It is clear that the TVM operates effectively from a constant current source if R_1 is sufficiently high in

value and the voltage drop across R_1 provides negative feedback for transistors Q_1 and Q_2 . Thus accuracy of calibration is maintained over a wide range of temperature.

Disadvantage. The chief disadvantage of a transistorized voltmeter shown in Fig. 20'9 is its comparatively low input resistance. However, a high resistance comparable to that of a VTVM can be achieved by designing a TVM with field effect transistors (FETs) as bridge-circuit components.

20.14. Differential Voltmeter. One of the most accurate method of measuring an unknown voltage is the "differential voltmeter technique", where the unknown voltage is compared with a known voltage. The principle of operation of the differential voltmeter is similar to a potentiometer and for that reason, the instrument is sometimes called a "potentiometric voltmeter".

The basic circuit for differential voltage measurement is shown in Fig. 20'10. A precision resistance potential divider is used to divide down an accurately known reference voltage.

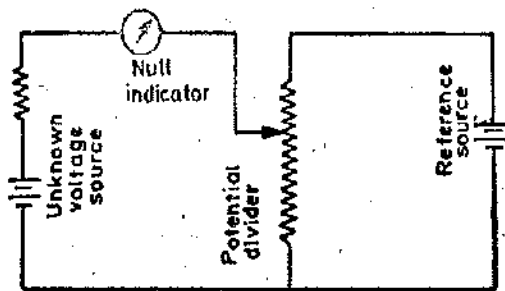

Fig. 20'10. Basic circuit for a differential voltmeter.

The adjustments on the potential divider are done till the output voltage equals the input (unknown) voltage. Under balance (null) conditions, neither the input source nor the reference delivers any current to the null indicator, and thus the differential voltmeter offers an infinite impedance to the source under test.

In order to detect small difference between input and reference voltages, a sensitive null indicator is required. The accuracy of null indicator is of secondary importance since the meter is used to indicate only null conditions and not to indicate the absolute value of unknown voltage.

The reference source usually consists of a low voltage d.c. standard, such as 1-V laboratory reference standard or a low voltage Zener-controlled d.c. source.

In order to measure high voltages, a high voltage reference source is used. The voltmeter employs a Kelvin Varley Slide (See Fig. 13'8 page 434) and the voltage is directly read off the dial when null is indicated.

The usual practice, however is to use a low, voltage reference source and to bring the input voltage down to the level of the reference voltage with the help of a resistance potential divider. But the disadvantage of this system is that on account of use of a potential divider, the input resistance of the voltmeter is no longer infinite and thus meter has a loading effect which is undesirable.

A further form of d.c. differential voltmeters employs a self-balancing potentiometer. The difference voltage between the input voltage and the voltage on the potentiometer is amplified and applied to a motor which is used to drive the scale and potentiometer slide wire past a pointer and slide wire contact until the voltage on the latter is equal to the input voltage. This instrument is greatly suitable for indicating small d.c. voltages such as the output voltages of thermocouples. The scale may be directly calibrated in terms of temperature.

The a.c. differential voltmeter is a modification of the d.c. voltmeter and involves the use of a precision rectifier circuit. The unknown a.c. voltage is applied to the rectifier for conversion to a d.c. voltage equivalent to the a.c. The resulting d.c. voltage is then applied to the potentiometric voltmeter as described earlier. The simplified block diagram of an a.c. differential voltmeter is shown in Fig. 20'11.

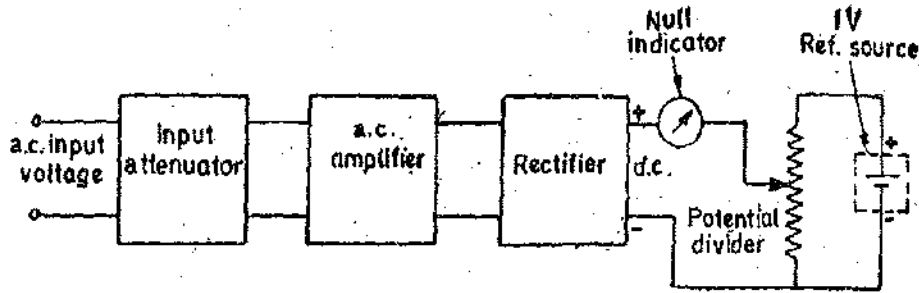

Fig. 20'11. Simplified block diagram of an a.c. differential voltmeter.

20'15. A.C. Voltage Measurements. Electronic a.c. voltmeters are essentially identical to d.c. voltmeters except that a.c. signal may be rectified before it can be applied to the PMMC meter movement. When the a.c. voltage is rectified before amplification, a d.c. amplifier is needed. While when rectification takes place after amplification, an a.c. amplifier is used.

The first system i.e. the signal is rectified and then amplified by a direct coupled d.c. amplifier is an attractive proposition on account of the fact that these amplifiers are economical ; and the arrangement is found in most of lower priced voltmeters.

Where a.c. voltage is rectified and amplified by a d.c. amplifier before being fed to a d.c. electronic voltmeter, the rectifier unit may be enclosed in the voltmeter case itself.

Frequently the rectifier unit is constructed as an a.c. probe whose output is fed to the d.c. electronic voltmeter by means of a shielded cable.

The circuit of such a probe is given in Fig. 20'12. Diode D is the rectifier, R_1 is its load resistor and capacitor C_1 is a blocking capacitor to keep any d.c. component of the voltage under test from entering the probe. Resistor R_2 and capacitor C_2 form an R - C filter to remove the a.c. component from the rectified voltage that is applied to the electronic voltmeter.

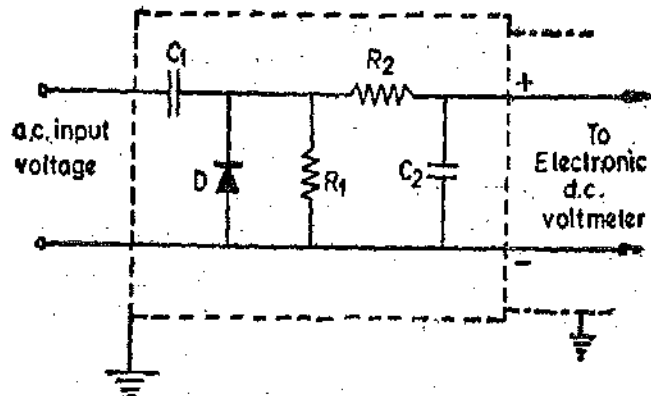

Fig. 20'12. Circuit of a.c. probe used with a d.c. electronic voltmeter.

20'15. R.M.S. Reading Voltmeter. The rms value of voltage is usually of principle interest. The average reading voltmeter can be converted into an rms reading voltmeter by calibrating the meter scale in terms of the rms value of a sine wave. Since so many waveforms in electronics are sinusoidal, the average reading voltmeter with an rms calibrated scale is an entirely satisfactory instrument. In fact an average reading voltmeter with a calibrated rms scale is much less expensive than a true rms reading voltmeter.

It has been pointed out earlier that readings of average reading voltmeter calibrated to read rms values are accurate for only sinusoidal inputs. Any departure from a true sinusoidal waveform causes an appreciable error. Complex waveforms are therefore most accurately measured with an rms responding Voltmeter.

This meter provides an output by sensing the heating power of the waveform. Since the heating power of the waveform is proportional to the square of the rms value of the voltage, the scale of the instrument can be calibrated to read the rms value directly. In practice, the heating power is measured by measuring an amplified version of the input waveform to the heater element of a thermocouple whose output voltage is proportional to the square of the rms value of input voltage.

Fig. 20.13 shows a true rms reading voltmeter. It uses two thermocouples. One is called the "measuring thermocouple" and other is called "balancing thermocouple". The balancing thermocouple is used in the feedback loop to cancel out the non-linear effect of the measuring thermocouple.

The two thermocouple elements form part of a bridge circuit connected to the input of a d.c. amplifier. The unknown a.c. voltage is amplified and applied to the heating element of the measuring thermocouple. Heating produces an output voltage which upsets the balance of the bridge.

The voltage on account of unbalance is amplified by a d.c. amplifier and is fed back to the heater element of the balancing thermocouple. Balance is re-established when the voltage output of the two thermocouples is equal. This happens when the d.c. current in the heater element of the balancing thermocouple is equivalent to the a.c. current in the heater element of measuring thermocouple. The d.c. current is directly proportional to the rms value of input voltage. The PMMC meter may be calibrated to read the rms voltage directly.

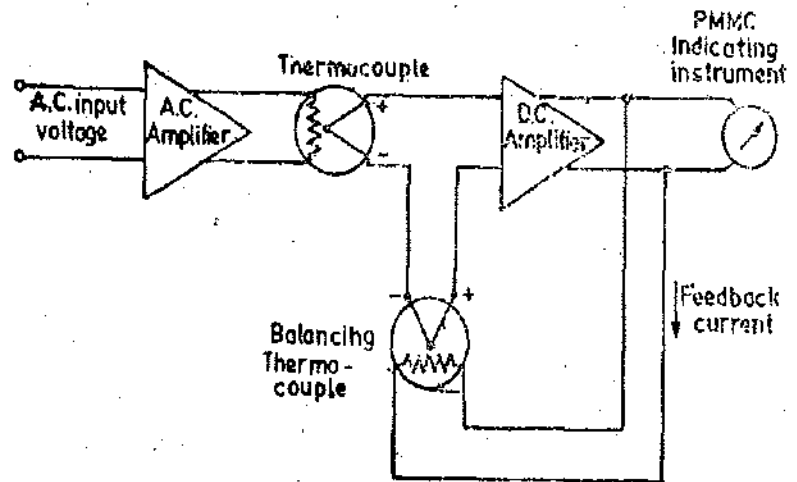

Fig. 20.13. True rms reading voltmeter.

20.16. Current Measurements Using Electronic Instruments

1. **D.C. Current Measurements.** Electronic voltmeters are frequently constructed to act as multipurpose instruments so that they can be used to measure current as well as voltage. The unknown current is made to flow through a known standard resistance. The voltage drop across this resistance is proportional to the current and is measured by a VTVM or a TVM. The scale of the meter is calibrated in terms of current.

2. **A.C. Current Measurements.** When alternating current is to be measured, a rectifier is used to change the alternating current to a corresponding direct current, which is then measured by a VTVM or TVM as explained above.

Another method employs an a.c. current probe which enables the a.c. current to be measured without disturbing the circuit under test. The a.c. current probe clips around the wire carrying the current and in effect makes the wire a one turn primary of a current transformer. The C.T. has a ferrite core and the secondary consists of a large number of turns. The voltage induced in the secondary winding is amplified and the amplifier's output can be measured by any suitable a.c. voltmeter. Normally the amplifier is designed so that 1 mA current in the wire being measured produces 1 mV at the amplifier output. The current is then read directly on the voltmeter, using the same scale as for voltage measurements.

20.17. **Instruments for Measurement of Power at Higher Frequencies.** We frequently need to measure the output power of certain electron devices such as amplifiers and oscillators. The frequencies involved in such devices are generally audio frequencies (upto approximately 15 kHz) or radio frequencies (above 15 kHz). The dynamometer type of wattmeters are not suitable for measurement of power at high frequencies since they are designed to operate on power frequencies.

There are a number of methods for measurement of power at high frequencies. The simplest methods, perhaps, is to connect a dummy load to the output terminals of the device under test. Then either the voltage drop across the dummy load or the current through the dummy load is measured using instruments like rectifier or thermocouple types. (These instruments are used because they can work at higher frequencies). Knowing the resistance, R , of the dummy load we can calculate the power output.

$$\text{Power output } P = E^2/R = I^2 R.$$

where E is the voltage across the dummy load while I is the current through it.

1. **Measurement of Power at Audio Frequencies (A.F.).** The basic circuit for measurement of power output of an audio frequency amplifier or oscillator is shown in Fig. 20'14.

A non-inductive type resistance R forms the dummy load and is connected across the output terminals of the device under test. The value of resistance R should be approximately equal to that of the output impedance of the device. Also the resistance value should be high enough to dissipate safely the power output. The a.c. voltmeter is a high resistance rectifier type of instrument. If this voltmeter is used with a fixed value of R (resistance of dummy load) its scale can be directly calibrated in terms of power output at audio frequencies.

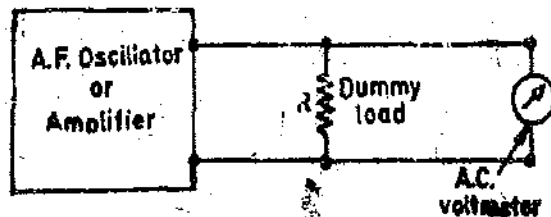

Fig. 20'14. Basic circuit for measurement of power output at audio-frequencies.

Decibels (db). The a.c. voltmeters used for measurement of power output are provided with decibel (abbreviated as db) scales. The scales provide measurement of power levels in decibels under certain conditions. Measurements of power output in terms of decibels is quite customary in audio frequency ranges.

The decibel is a logarithmic unit to express power ratios. If the powers being compared are P_1 and P_2 , then,

$$\text{decibels db} = 10 \log_{10} \frac{P_2}{P_1} \quad \dots(20'2)$$

The sign associated with decibels indicates which power is greater. A positive sign means that P_2 is greater than P_1 while a negative sign means that P_2 is less than P_1 .

The advantages of a db scale lie in its logarithmic nature. This permits the use of a very wide scale range of power to be expressed in terms of db without running into inconveniently large numbers, while at the same time permitting small ratios to be conveniently expressed. For example 0 db represents a ratio of 1 while 1 db represents an approximate ratio of 1.25 and 60 db represents a ratio of 1000,000.

In our case, the power is measured in terms of a voltage and a resistance or a current and a resistance. If the resistance value is the same, we can express decibels as :

$$\text{db} = 10 \log_{10} \frac{E_2^2/R}{E_1^2/R} = 20 \log_{10} \frac{E_2}{E_1} \quad \dots(20'3)$$

$$= 10 \log_{10} \frac{I_2^2 R}{I_1^2 R} = 20 \log_{10} \frac{I_2}{I_1} \quad \dots(20'4)$$

It is clear from Eqn. 20'3, the scale of a voltmeter can be expressed in terms of db.

There are several different reference levels used for decibel scale. One type establishes the zero reference level as 1 mW power dissipated in a 600 Ω resistance. Now $P = E^2/R$.

$$\therefore E = \sqrt{1 \times 10^{-3} \times 600} = 0.7746 \text{ V.}$$

Since 0 db means the two powers P_1 and P_2 should be equal, the 0 db point corresponds to 0.7746 V on the voltmeter scale.

The second method places the 0 db reference as 6 mW in 500 Ω . This method places the 0 db point at 1.732 V on the voltmeter scale.

Meters using these methods will read directly in decibels when they are across the load resistance for which their 0 db reference is established, and the range switch is in 0 db position. For all other range-switch settings algebraic sum of the scale reading and the range switch indication must be taken. Power levels above 0 db are termed positive and those below 0 db are negative.

Decibels may be converted into watt by the following relationship which follows from Eqn. 20'2.

$$\text{Power output } P_2 = P_1 \text{ antilog}_{10} \text{ db}/10 \text{ watt} \quad \dots(20'5)$$

2. **Measurement of Power at Radio Frequencies (R.F.).** The basic circuit for measurement of power of a radio frequency (R.F.) amplifier or oscillator is shown in Fig. 20.15.

The output tank of the device under test consists of capacitor C_1 and inductor L_1 . Radio frequency (R.F.) power from this tank is transmitted to dummy load consisting of inductance L_4 , capacitance C_2 and resistance R in series with a R.F. thermocouple ammeter, by means of an inductive link (L_2, L_3) that couples L_1 and L_4 .

The dummy load is tuned to resonance at the resonant frequency of the tank circuit with the help of variable capacitor C_2 . Thus at resonant frequency the dummy load is only the resistance R . This resistance R must be non-inductive or otherwise it will add an undesirable impedance factor to the circuit. Resistance R should also be capable of dissipating much more power than that the wattmeter will measure so that heat developed will not cause any change in its value.

If resistance R is non-inductive and is constant in magnitude (known) irrespective of the value of current, the thermocouple instrument can be directly calibrated to read the value of power.

Well designed meters of this type can be used at frequencies upto 30 MHz, but effective shielding must be used for measurement of power at higher frequencies. The resistance R_1 may be a source of R.F. energy leakage at higher frequencies and reduce the accuracy giving higher values than true ones.

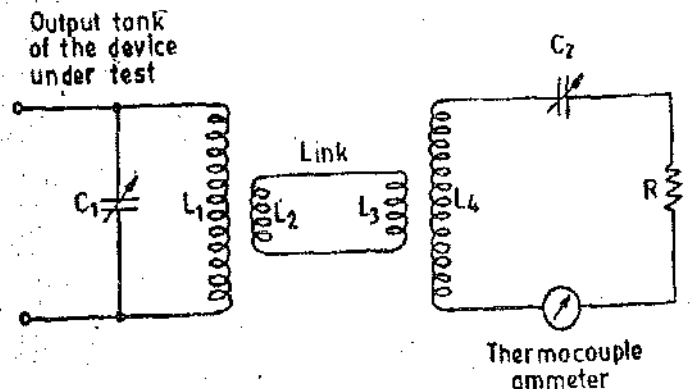

Fig. 20.15. Basic circuit for measurement of power at radio frequencies.

Cathode Ray Oscilloscope (CRO)

21.1. Introduction. The cathode ray oscilloscope (CRO) is a very useful and versatile laboratory instrument used for display, measurement and analysis of waveforms and other phenomena in electrical and electronic circuits. CROs are in fact very fast $X-Y$ plotters, displaying an input signal versus another signal or versus time. The "stylus" of this "plotter" is a luminous spot which moves over the display area in response to an input voltage. The luminous spot is produced by a beam of electrons striking a fluorescent screen. The extremely low inertia effects associated with a beam of electrons enables such a beam to be used for following the changes in instantaneous values of rapidly varying voltages. The extremely low inertia of electrons as compared to metallic conductors used in an electromechanical oscilloscope (Duddell's oscilloscope described in Art. 7.26 page 184) enable a CRO to be used at frequencies much above the highest on which the Duddell's oscilloscope can be used.

The normal form of a CRO uses a horizontal input voltage which is an internally generated ramp voltage called "Time Base". This horizontal voltage moves the luminous spot periodically in a horizontal direction from left to right over the display area or screen. The vertical input to the CRO is the voltage under investigation. The vertical input voltage moves the luminous spot up and down in accordance with the instantaneous value of the voltage. The luminous spot thus traces the waveform of the input voltage with respect to time. When the input voltage repeats itself at a fast rate, the trace (display) on the screen appears stationary on the screen. The CRO thus provides a means of visualizing time varying voltages. As such, the CRO has become a universal tool in all kinds of electrical and electronic investigations.

CROs operate on voltages. However, it is possible to convert current, strain, acceleration, pressure and other physical quantities into voltages with the help of transducers and thus to present visual representations of a wide variety of dynamic phenomena on CROs.

CROs are also used to investigate waveforms, transient phenomena, and other time varying quantities from a very low frequency range to the radio frequencies.

21.2. Cathode Ray Tube (CRT). A cathode ray oscilloscope consists of a cathode ray tube (CRT), which is the heart of the tube, and some additional circuitry to operate the CRT. The main parts of a CRT are :

- (i) Electron gun assembly, (ii) Deflection plate assembly, (iii) Fluorescent screen,
- (iv) Glass envelope, (v) Base, through which connections are made to various parts.

The main parts of a CRO are shown in Fig. 21.1. Before going into details of working of various parts of a CRO, a summary of functions of the different parts is given below :

The "Electron gun assembly" produces a sharply focused beam of electrons which are accelerated to high velocity. This focused beam of electrons strikes the fluorescent screen with sufficient energy to cause a luminous spot on the screen.

After leaving the electron gun, the

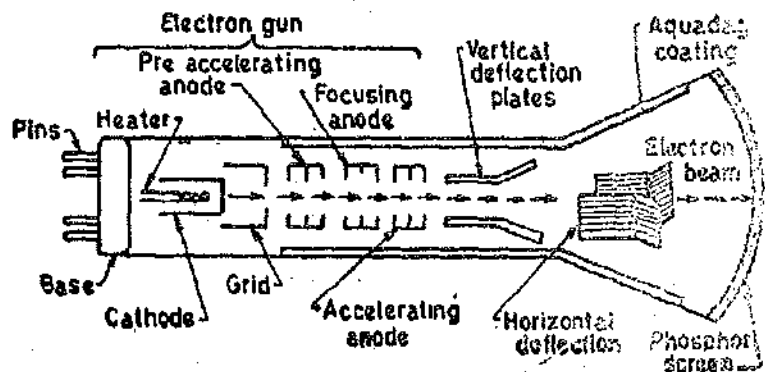

Fig. 21.1. Internal structure of a CRT.

electron beam passes through two pairs of "Electrostatic deflection plates". Voltages applied to these plates deflect the beam. Voltages applied to one pair of plates move the beam vertically up and down and the voltages applied to the other pair of plates move the beam horizontally from one side to another. These two movements *i.e.* horizontal and vertical are independent of each other and thus the beam may be positioned anywhere on the screen.

The working parts of a CRT are enclosed in an evacuated glass envelope so that the emitted electrons are able to move about freely from one end of the tube to the other.

21'3. Electron Gun. The source of focused and accelerated electron beam is the electron gun. The electron gun, which emits electrons and forms them into a beam, consists of a heater, a cathode, a grid, a pre-accelerating anode, a focusing anode and an accelerating anode.

In smaller CRTs, connections to the various electrodes are brought out through pins in the base of the tube as shown in Fig. 21'1. Larger types and medium sized high performance tubes operate at very high voltages, and these leads are usually brought out through the sides of the glass envelope.

Electrons are emitted from the indirectly heated cathode. A layer of barium and strontium oxide is deposited on the end of the cathode—which is a cylinder—to obtain high emission of electrons at moderate temperatures. These electrons pass through a small hole in the "control grid". This control grid is usually a nickel cylinder, with a centrally located hole, co-axial with the CRT axis. The intensity of electron beam depends upon the number of electrons emitted from the cathode. The grid with its negative bias controls the number of electrons emitted from the cathode and hence the intensity is controlled by the grid.

The electrons, emitted from the cathode and passing through the hole in the control grid are accelerated by the high positive potential which is applied to the "pre-accelerating" and "accelerating anodes".

The electron beam is focused by the "focusing anode". The accelerating and focusing anodes are cylindrical in form, with small openings located in the centre of each electrode, coaxial with the tube axis. After leaving the focusing anodes, the electron beam passes through the vertical and horizontal deflection plates and then goes on to the fluorescent screen.

There are two methods of focusing an electron beam :

(i) Electrostatic focusing and (ii) Electromagnetic focusing. The CRO uses electrostatic method of focusing as compared to a TV picture tube which employs electromagnetic focusing.

21'4. Electrostatic Focusing. Fig. 21'2 shows an electron at rest placed in an electric field produced two parallel plates. Force on the electron is

$$F = -eE \text{ newton} \quad \dots(21'1)$$

where E = electric field intensity ; V/m, and e = charge of electron = 1.602×10^{-19} C.

The minus sign indicates that the force acts in the opposite direction to that of the field. The above discussion is valid only if the electron is situated in a field of uniform intensity. In practice, however, the field is not uniform. The lateral repulsion of the electric field lines causes a spreading of

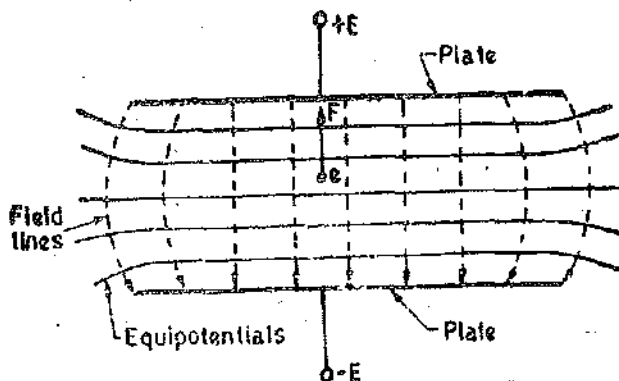

Fig. 21'2. Electric field between parallel plates.

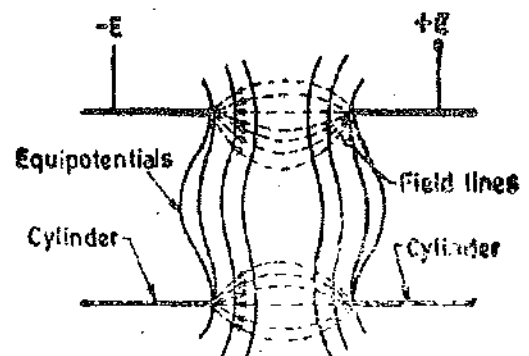

Fig. 21'3. Field between two co-axial cylinders.

space between the lines, resulting in curved field lines at the ends. Thus the field intensity will be less at the ends. Fig. 21'2 also shows equipotential surfaces, indicated by solid lines. Since the force is in a direction opposite the field and the equipotential surfaces are perpendicular to the field, the force on an electron is in a direction normal to the equipotential surfaces.

Fig. 21'3 shows two concentric cylinders with a potential applied between them. Lateral repulsion again causes the spreading of the flux lines producing a field as shown. The equipotential surfaces are shown as solid lines. It is clear from the diagram that the equipotential surfaces are curved. Let us consider the region on the two sides of an equipotential surface *S* as shown in Fig. 21'4. The potential on the left side of the surface is $-V$ and on the right side is $+V$. Let an electron moving in a direction *AB* enter the area to the left of *S*. This electron experiences a force which is normal to the surface *S* and is thus accelerated.

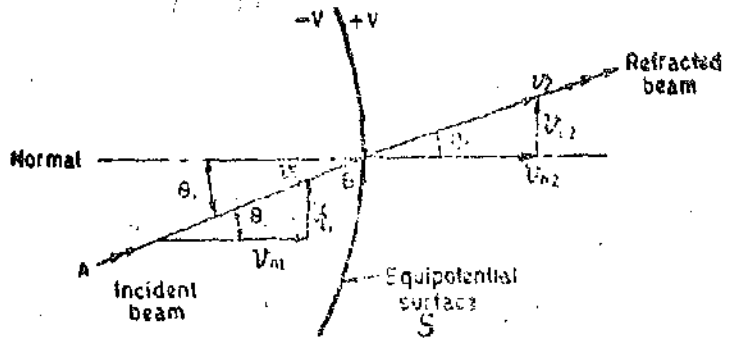

Fig. 21'4. Refraction of an electron beam.

Since the force acts in a direction normal to the surface, it is the normal component of velocity that is increased after refraction while the tangential component remains the same.

The tangential components are :

$$v_{t1} = v_1 \sin \theta_i \quad \text{and} \quad v_{t2} = v_2 \sin \theta_r$$

Now $v_{t1} = v_{t2}$ or $v_1 \sin \theta_i = v_2 \sin \theta_r$

$$\therefore \frac{\sin \theta_i}{\sin \theta_r} = \frac{v_2}{v_1} \quad \dots(21'2)$$

where

v_1 = initial velocity of electrons, v_2 = velocity of electrons after leaving surface *S*,
 θ_i = angle of incidence, and θ_r = angle of refraction..

Eqn. 21'2 is identical to the expression relating the refraction of a light beam in geometrical optics. The refraction of an electron beam follows as the bending of a light beam at a refracting surface such as an optical lens. For this reason the focusing system in a CRT is known as electron lens.

Fig. 21'5 shows the functional diagram of an electrostatic focusing arrangement. The pre-accelerating anode, which is a metal cylinder containing any baffles, collimates the electron beam which enters it through a small opening on the left hand side. The pre-accelerating anode is connected to a high positive potential.

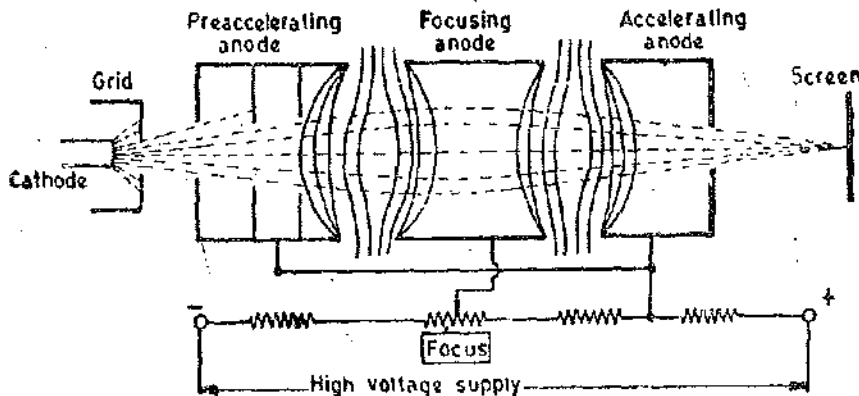

Fig. 21'5. Electrostatic focusing arrangement.

The focusing anode and the accelerating anodes are co-axial with the pre-accelerating anode. The pre-accelerating and accelerating anodes are connected to the same potential while the focusing anode is connected to a lower potential.

On account of difference of potential between focusing anode and the two accelerating anodes a non-uniform field exists on each of the two ends of the focusing anode. The equipotential surfaces, thus, form a "double concave lens".

The electron beams entering the field at angles other than the normal to the equipotential surfaces, will be deflected towards the normal and the beam is thus focused towards the centre of the tube axis. By changing the voltage of the focusing anode, the refractive index of the electron lens is changed and therefore the focal point of the beam can be changed. The change in voltage is brought about by changing the setting of a potentiometer. This control is brought to the front panel of CRO and is marked Focus.

21.5. Electrostatic Deflection. Fig. 21.6 shows a general arrangement for electrostatic deflection. There are two parallel plates with a potential applied between. These plates produce a uniform electrostatic field in the Y direction. Thus any electron entering the field will experience a force in the Y direction and will be accelerated in that direction. There is no force either in X direction or Z direction and hence there will be no acceleration of electrons in these directions.

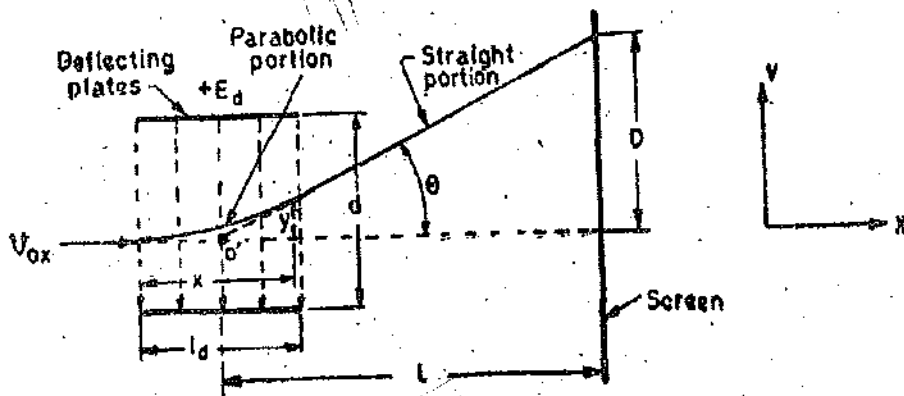

Fig. 21.6. Electrostatic deflection.

Let E_a = voltage of pre-accelerating anode ; V, e = charge of an electron ; C,
 m = mass of electron ; kg,
 v_{ox} = velocity of electron when entering the field of deflecting plates ; m/s,
 E_d = potential between deflecting plates ; V, d = distance between deflecting plates ; m,
 l_d = length of deflecting plates ; m,
 L = distance between screen and the centre of the deflecting plates ; m,
 and D = deflection of electron beam on the screen in Y direction ; m.

The loss of potential energy (P.E.) when the electron moves from cathode to accelerating anode ; P.E. = eE_a ... (21.3)

The gain in kinetic energy (K.E.) by an electron $K.E. = \frac{1}{2} m v_{ox}^2$... (21.4)

(The mass of an electron is $m = 9.109 \times 10^{-31}$ kg)

Equating the two energies, we have : $v_{ox} = (2 e E_a / m)^{1/2}$... (21.5)

This is the velocity of the electron in the X direction when it enters the deflecting plates. The velocity in the X direction remains the same throughout the passage of electrons through the deflecting plates as there is no force acting in this direction.

The electric field intensity in the Y direction $E_y = \frac{E_d}{d}$... (21.6)

Force acting on an electron in Y direction $= F_y = e\epsilon_y = e \frac{E_d}{d}$... (21.7)

Suppose ϵ_y is the acceleration of the electron in Y direction therefore, $F_y = ma_y$

or
$$a_y = \frac{e \epsilon_y}{m} \quad \dots (21.8)$$

As there is no initial velocity in the Y direction the displacement y at any instant t in the Y direction is :

$$y = \frac{1}{2} a_y t^2 = \frac{1}{2} \frac{e\epsilon_y}{m} t^2 \quad \dots (21.9)$$

As the velocity in X direction is constant, the displacement in X direction is given by :

$$x = v_{ox} t \quad \dots (21.10)$$

$$t = \frac{x}{v_{ox}} \quad \dots (21.11)$$

Substituting the above value of t in Eqn. 21.9, we have :

$$y = \frac{1}{2} \frac{e\epsilon_y}{m v_{ox}^2} x^2 \quad \dots (21.12)$$

This is the equation of a parabola.

The slope at any point (x, y) is: $\frac{dy}{dx} = \frac{e\epsilon_y}{m v_{ox}^2} x$... (21.13)

Putting $x = l_a$ in Eqn. 21.13, we get the value of $\tan \theta$.

or
$$\tan \theta = \frac{e\epsilon_y}{m v_{ox}^2} l_a = \frac{e E_d l_a}{m d v_{ox}^2} \quad \dots (21.14)$$

After leaving the deflection plates, the electrons travel in a straight line. The straight line of travel of electrons is tangent to the parabola at $x = l_a$ and this tangent intersects the X -axis at point O' . The location of this point is given by :

$$x = \frac{y}{\tan \theta} = \frac{e\epsilon_y l_a^2}{2m v_{ox}^2} \left/ \frac{e\epsilon_y}{m v_{ox}^2} l_a = \frac{l_a}{2} \right.$$

The apparent origin is thus at the centre of deflection plates. The deflection D on the screen is given by :

$$D = L \tan \theta = \frac{L e E_d l_a}{m d v_{ox}^2} \quad \dots (21.15)$$

Substituting the value $v_{ox}^2 = \frac{2e E_a}{m}$ in Eqn. 21.15, we get

$$D = \frac{L e E_d l_a}{m d} \cdot \frac{m}{2e E_a} = \frac{L l_a E_d}{2d E_a} \text{ metre} \quad \dots (21.16)$$

From Eqn. 21.16 we conclude :

(i) For a given accelerating voltage E_a , and for particular dimensions of CRT, the deflection of the electron beam is directly proportional to the deflecting voltage. This means that the CRT may be used as a linear indicating device.

(ii) The discussion above assumes that E_a is a fixed d.c. voltage. The deflection voltage is usually a time varying quantity and the image on the screen thus follows the variations of the deflection voltage in a linear manner.

(iii) The deflection is independent of the e/m ratio. In a cathode ray tube, in addition to the electrons many types of negative ions such as oxygen, carbon, chlorine etc. are present. With

electrostatic deflection system), because deflection is independent of e/m , the ions travel with the electrons and are not concentrated at one point. Hence cathode ray tube with electrostatic deflection system does not produce an ion burn.

Deflection Sensitivity. The deflection sensitivity of a CRT is defined as the deflection of the screen per unit deflection voltage.

$$\therefore \text{Deflection sensitivity } S = \frac{D}{E_a} = \frac{Ll_a}{2dE_a} \text{ metre/volt} \quad \dots(21'17)$$

The **Deflection Factor** of a CRT is defined as the reciprocal of sensitivity.

$$\therefore \text{Deflection factor } G = \frac{1}{S} = \frac{2dE_a}{Ll_a} \text{ volt/metre} \quad \dots(21'18)$$

It is clear from Eqn. 21'17, that the sensitivity can be increased by decreasing the value of accelerating voltage E_a . But this has a disadvantage as the luminosity of the spot is decreased with decrease in E_a . On the other hand a high value of E_a , produces a highly accelerated beam and thus produces a bright spot. However, a high accelerating voltage (E_a) requires a high deflection potential (E_d) for a given deflection. Also highly accelerated beam is more difficult to deflect and is sometimes called **hard beam**. Typical values of sensitivities are 0'1 mm/V to 1'0 mm/V corresponding to deflection factors of 10 V/mm and 1 V/mm.

21'6. Effect of Beam Transit Time and Frequency Limitations. In the derivation of Eqn. 21'16, the plate voltage E_a is assumed constant during the motion of the electrons through the deflecting field. If the voltage applied to the vertical deflecting plates changes during the transit time of the electrons through the horizontal plates, the deflection sensitivity gets decreased.

$$\text{Transit time } t_1 = \frac{l}{v_{0z}} \quad \dots(21'19)$$

The transit time imposes a limitation of the upper frequency limit. An upper limiting frequency is defined as that frequency at which the transit time is equal to one quarter of the period of the voltage applied to vertical plates.

$$\therefore \text{Upper limiting frequency } f_c = \frac{1}{4t_1} = \frac{v_{0z}}{4l} \quad \dots(21'20)$$

The frequency range of the oscilloscopes can be increased by subdividing the deflecting plates in a number of sections in the path of the electron beam. The voltage being measured is applied to the vertical plates through an iterative network, whose propagation time corresponds to the velocity of electrons, thereby the voltage applied to the vertical plates is made to synchronize with the velocity of the beam. The use of this technique allows the cathode ray oscilloscope upto frequencies of 500 MHz and above.

21'7. Deflection Plates. Referring to Fig. 20'1, we observe that the electron beam, after leaving the electron gun, passes through two pairs of deflection plates. One pair of plates is mounted horizontally and produces an electric field in the vertical plane. This pair produces a vertical deflection and is thus called **Vertical Deflection Plates** or **Y Plates**. The other pair of plates is mounted vertically and produces a horizontal deflection. This pair of plates is called **Horizontal Deflection Plates** or **X Plates**. The plates are flared so as to allow the beam to pass through them without striking the plates.

21'8. Screens for CRTs. The screen material on the inner surface of a CRT is called **Phosphor**. This material absorbs the kinetic energy of the bombarding electrons and re-emits it in the form of a bright spot.

Several materials of different characteristics are used. The commonly used materials are listed in Table 21'1.

TABLE 21.1
CRT Phosphor Materials and Characteristics

Phosphor Type	Trace Colour		Persistence	Applications
	Under excitation	After glow		
P. 1	green	green	medium	General purpose CRO. Satisfactory for photographing. Good for visual work.
P. 2	yellow-green	yellow-green	medium, short	Observation of low and medium speed non-recurrent phenomena. Very suitable for slowly varying signals.
P. 4	white	yellow	medium	Used in T.V. displays.
P. 7	blue-white	yellow-green	long	Observation of low-speed recurrent or medium speed nonrecurrent phenomena.
P. 11	blue	blue	medium, short	Good for photographic work. Mainly used in high speed oscillography.
P. 31	green	green	medium, short	General purpose phosphor. Observation of low or medium speed non-recurrent phenomena.

The bombarding electrons, striking the screen, release secondary emission electrons. These secondary electrons are collected by an aqueous solution of graphite, called aquadag which is connected to the second anode. Collection of secondary electrons is necessary to keep the screen in a state of electrical equilibrium.

21.9. CRT Graticule. The graticule is usually rectangular in form and is placed inside the display area to allow correct measurements. Most CROs have a graticule inscribed on a clear or tinted plastic plate, placed over the outside of the CRT face.

21.10. Time Base Generators. Most of the CRO applications involve measurement or display of a quantity which varies with respect to time. This requires that the CRT spot move across the screen from left to right with a constant velocity. In order that the beam deflect linearly from left to right, ramp voltages are applied to horizontal deflection or X plates. The circuits which develop these ramp voltage are called time base generators or sweep generators. The output of a sweep generator is called a sweep voltage.

The typical form of a time-base voltage is shown in Fig. 21.7 (a). This voltage, starting from some initial value, increases linearly with time, to a maximum value, after which it again returns to its initial value. Time T_s is called the sweep time while time T_r is called the retrace time or flyback time. Fig. 21.7 (b) shows an idealized form of sweep voltage, where the voltage is linear during the sweep time and the fly-back time is zero. Time base generators do not necessarily provide sweep voltages that are exactly linear, although every attempt is made to obtain reasonable linearity of rise of voltage.

A simple sweep generator uses an RC circuit wherein a switch is used to charge and discharge.

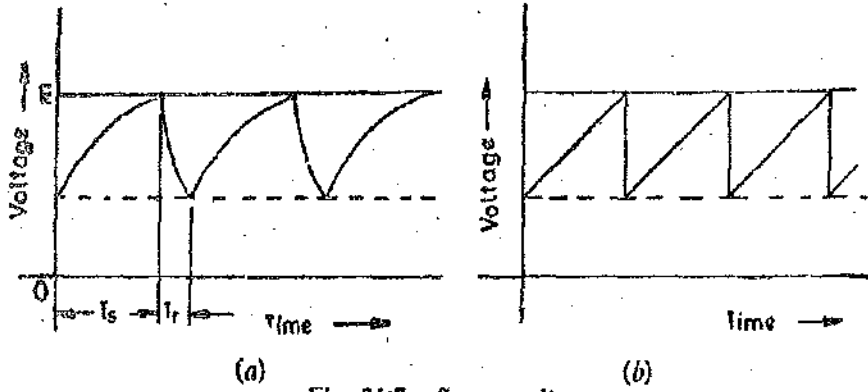

Fig. 21.7. Sweep voltages.

a capacitor. The switch may be a vacuum tube, a gas filled tube, a SCR, a transistor or any other semi-conducting device depending upon the application, speed required, and many other factors.

Fig. 21.8 (a) shows a sweep generator using a thyatron. Capacitor C charges exponentially through R , approaching the supply voltage E_{bb} as shown in Fig. 21.8 (b). When the plate voltage

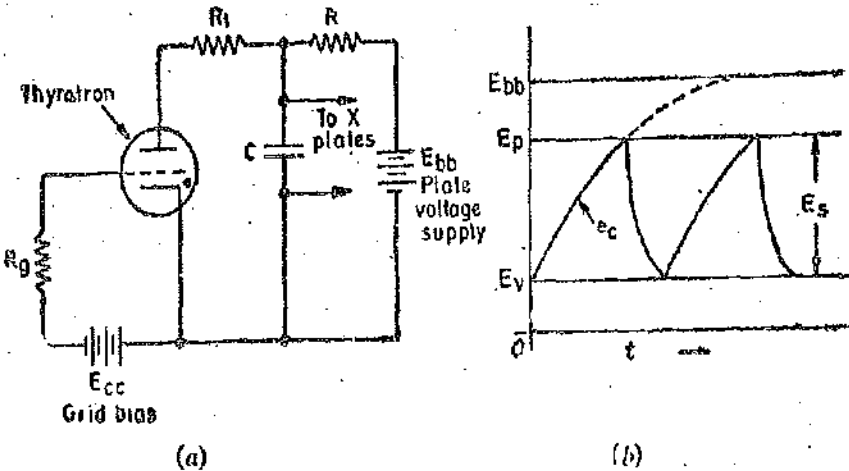

Fig. 21.8. Sweep generator circuit using thyatron.

reaches a value E_p which corresponds to breakdown voltage corresponding to the critical grid voltage, the thyatron ionizes and conducts heavily. The capacitor discharges rapidly through the tube and resistance R_1 till the capacitor voltage drops to a value E_v , which is the ionization potential of the thyatron. At this voltage the thyatron stops conducting and presents an infinite resistance and the capacitor starts charging again through resistance R . When its voltage reaches E_p , it discharges again. This process repeats itself, and the voltage e_c across the capacitor is a saw tooth wave. This voltage is fed to the X plates.

One method of linearization is to use a small portion of the exponential curve and if necessary, amplify this voltage before applying to the X plates. Better linearity, approaching the waveform given in Fig. 21.7 (b) may be obtained by replacing the resistance R , in circuit of Fig. 21.8 (b), with a pentode valve.

21.11. Basic CRO Circuits. Fig. 21.9 shows a block diagram of a typical oscilloscope. In the following few pages, we describe the basic circuitry of cathode ray oscilloscope.

1. Vertical (Y) Deflection System. The signals to be examined are usually applied to the vertical or Y deflection plates through an input attenuator and a number of amplifier stages. Vertical amplifier is required because the signals are not strong enough to produce measurable deflection on the CRT screen. The amplifier response must be wide enough to pass faithfully the entire band of frequencies to be measured.

When high voltage signals are to be examined, they must be attenuated to bring them within the range of vertical amplifiers. The vertical amplifier output is also applied to the synchronizing amplifier through the synchronizer selector switch in the internal position. This permits the horizontal sweep circuit to be triggered by the signal being investigated.

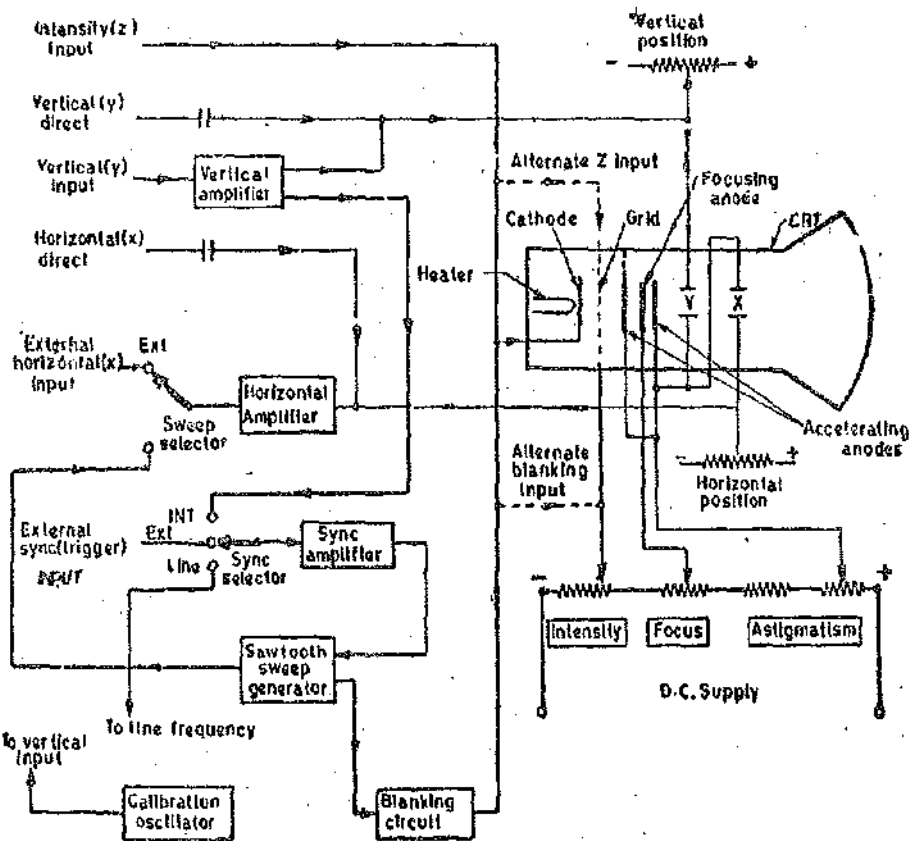

Fig. 21.9. Simplified block diagram of a general purpose oscilloscope.

2. Horizontal (X) Deflection System. The horizontal (X) deflection plates are fed by a sweep voltage that provides a time base. The horizontal plates are supplied through an amplifier, but they can be fed directly when voltages are of sufficient magnitude. When external signals are to be applied to the horizontal deflection system, they can also be fed through the horizontal amplifier, via the sweep selector switch in the external position. When the sweep selector switch is in the internal position, the horizontal amplifier receives an input from the saw tooth sweep generator which is triggered by the synchronizing amplifier.

Types of Sweeps. There are four basic types of sweeps :

(i) **Free Running or Recurrent Sweep.** In the free running or recurrent sweep, the sawtooth waveform is repetitive. A new sweep is started immediately after the previous sweep is terminated and the circuit is not initiated by any external signal.

(ii) **Triggered Sweep.** A waveform to be observed on the CRO may not be periodic but may perhaps occur at irregular intervals. In this case it is desirable that the sweep circuit remain inoperative and the sweep be initiated by the waveform under examination. In some cases the waveform may be periodic, but it may be that the interesting part of the waveform is of a very short duration compared to the period of the waveform. Under such cases a triggered sweep is used.

In triggered sweep or single sweep, the spot is swept once across the screen in response to a trigger signal. The triggered sweep is used for examination of transients, or one time signals and the waveform is photographed for record. The trigger can be obtained from the signal under investigation or by an external source.

(iii) **Driven Sweep.** In most cases, a driven sweep is used where the sweep is recurrent but triggered by the signal under test.

(iv) **Non Saw Tooth Sweep.** For some applications like comparison of two frequencies or for finding phase shift between two voltages, non sawtooth sweep voltages are utilized for the sweep circuit. Sweep frequencies vary with the type of oscilloscope. A laboratory oscilloscope may have

sweep frequencies upto several MHz ; a simple oscilloscope for audiowork has an upper limit of 100 kHz. Most TV service require a sweep voltage frequency upto 1 MHz.

3. **Synchronization.** Whatever type of sweep is used, it must be synchronized with the signal being measured. Synchronization has to be done to obtain a stationary pattern. This requires that the time base be operated at a submultiple frequency of the signal under measurement (applied to Y plates). If synchronization is not done, the pattern is not stationary, but appears to drift across the screen in a random fashion.

Sources of Synchronization. There are three usual sources for synchronization which can be selected by synchronizing selector :

(i) **Internal.** In this type of synchronization, the trigger is obtained from the signal being measured through the vertical amplifier.

(ii) **External.** In this method, an external trigger source is also used to trigger or initiate the signal being measured.

Line. In this case, the trigger is obtained from the power supply to the CRO (say 230 V, 50 Hz).

4. **Blanking Circuit.** The sawtooth sweep voltage applied to the X plates moves the beam across the CRT tube in a straight horizontal line from left to right during the sweep or trace time T_s . A comparatively slow movement of the spot will appear as a solid line, provided the rate of movement exceeds the threshold of persistence of vision. Below this threshold limit, a moving spot is perceived. On the other hand, the comparatively rapid movement of spot will appear as a thin and dim line, or may be invisible. Thus if the retrace or flyback time is very small, the spot remains invisible. In an ideal case the flyback time, T_r is zero and hence the spot while moving from right to left remains invisible. However in actual practice the flyback time is not zero and therefore the retrace (moving of beam from right to left *i.e.*, its starting point) may cause confusion. Thus the retrace should be eliminated or blanked out. The retrace is blanked out by applying a high negative voltage to the grid during the flyback period T_r . The blanking voltage is usually developed (or triggered) by sweep generator.

5. **Intensity (Z-Axis) Modulation.** Intensity modulation (Z-axis modulation) is done by inserting a signal between the ground and the cathode (or control grid). Z axis modulation is applied during normally visible portion of the trace.

The Z-axis modulation can be used for brightening the display. Periodic positive pulses are applied to the grid (alternatively negative pulses are applied to cathode) to brighten the beam during its sweep period. These periodically brightened spots may be used as markers for time calibration of the main waveform.

6. **Positioning Controls.** It is necessary to provide some means of positioning the trace on the screen. The positioning of the trace is done by applying small independent, internal d.c. voltages to the deflecting plates and control can be exercised by varying the voltage with help of potentiometers.

7. **Focus Control.** As mentioned earlier, the focusing electrode acts like a lens whose focal length can be changed. This change can be brought about by changing the potential of the focusing anode.

8. **Intensity Control.** The intensity of the beam is varied by the Intensity control potentiometer which changes the grid potential with respect to cathode. The grid potential determines the amount of electrons leaving the cathode and thus controls the intensity of the beam.

9. **Calibration Circuit.** Laboratory oscilloscopes normally have an internally generated and stabilized voltage of known amplitude which is used for calibration purposes. Usually the calibrating voltage has a square waveform.

10. **Astigmatism.** In most modern oscilloscopes there is an additional focusing control marked **Astigmatism**. This is used to correct an effect which exactly is analogous to astigmatism in optical lenses. To focus the spot correctly, it is necessary to stop it near the centre of the screen by

switching off the time base and adjusting the X and Y positioning controls. The spot is then made as sharp as possible by successive adjustment of focus and astigmatism controls.

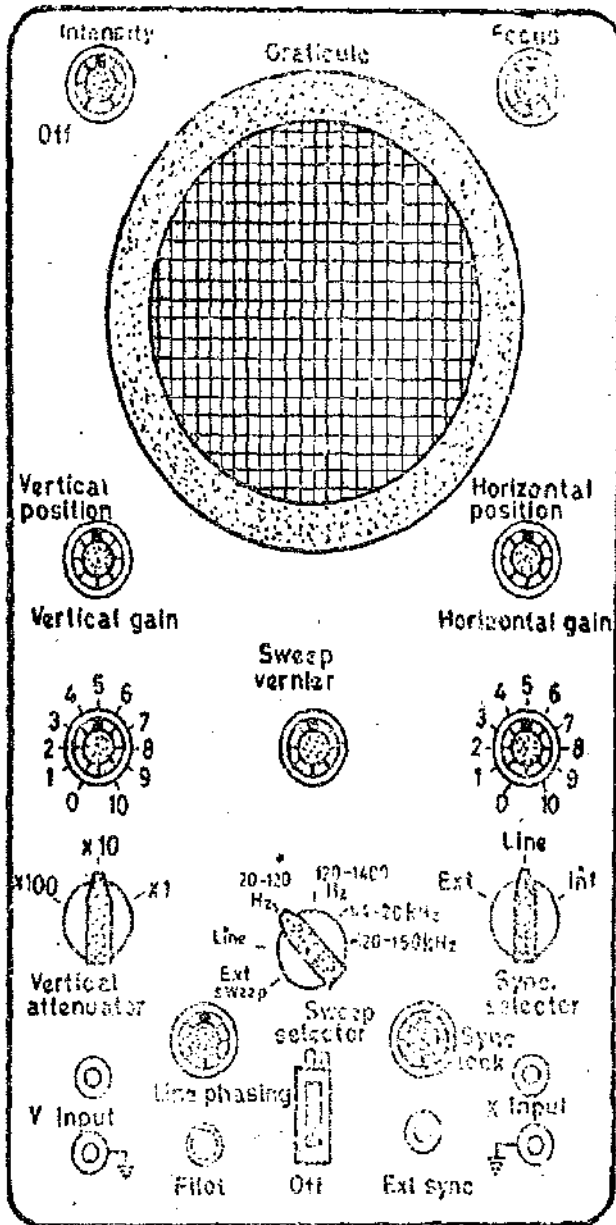

Fig. 21'10. Front panel of a general purpose CRO.

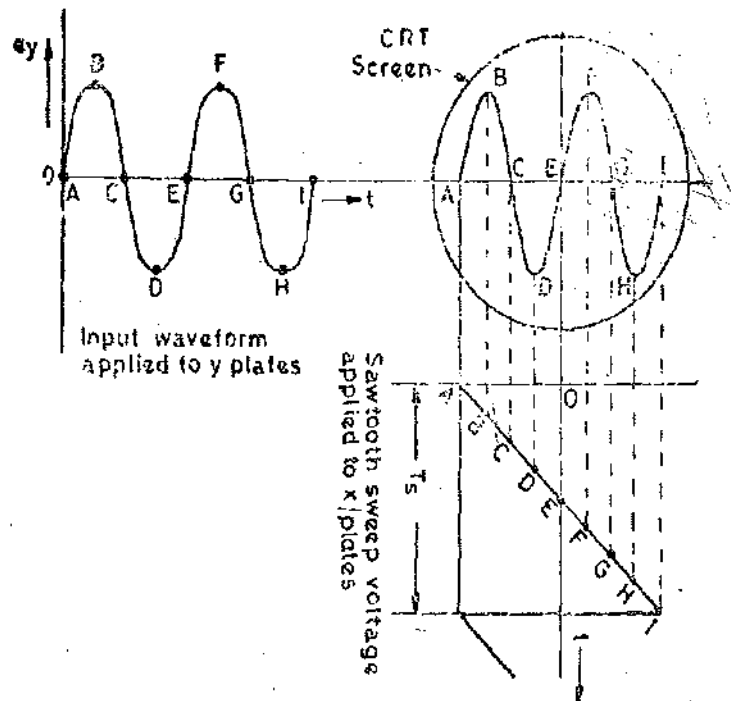

Fig. 21'11. Observation of waveform on CRO.

21'12. Observation of Waveform on CRO. In order to observe waveform on a CRO, the waveform of voltage under test is applied to Y plates and a voltage obtained from a sawtooth generator is applied to X plates. Let us assume that the sawtooth waveform has an idealized waveshape.

When simultaneously with the horizontal sawtooth (ramp) voltage, an input voltage is applied to vertical deflection (Y) plates, the beam is under the influence of two forces : (i) one in the horizontal direction moving the beam at a linear rate from left to right, (ii) and second in the vertical direction moving the beam up and down. Since the deflection is proportional to the voltage applied to the deflection plates, the horizontal movement is proportional to the voltage applied to X plates at any instant and since the ramp voltage is linear it traces a straight line on the CRT screen. The vertical deflection is proportional to the voltage applied to the Y plates at any instant and thus the beam moves up and down according to the magnitude and polarity of the input voltage. Fig. 21'11 shows the waveform displayed on a CRT tube due to an input sinusoidal voltage.

At the end of one sweep cycle, the sweep voltage abruptly drops down and the spot is

immediately transferred to its original position. The process is then repeated again, with the result, that a stationary image is seen on the screen.

For the case shown the frequency of the input voltage is twice that of sawtooth (sweep) voltage. To observe more than one cycle of the input voltage, the sweep voltage frequency has to be a submultiple of the input voltage frequency.

21.13. Measurement of Voltages and Currents. The expression for electrostatic deflection, given in Eqn. 21.16, shows that the deflection is proportional to the deflection-plate voltage. Thus the cathode-ray tube will measure voltage. It is usual to calibrate the tube under the given operating conditions by observing the deflection produced by a known voltage. Direct voltages may be obtained from the static deflection of the spot, alternating voltages from the length of the line produced when the voltage is applied to Y plates while no voltage is applied to X plates. The length of this line corresponds to the peak-to-peak voltage.

When dealing with sinusoidal voltages, the rms value is given by dividing the peak-to-peak voltage by $2\sqrt{2}$.

Laboratory oscillographs frequently incorporate voltage-measurement facilities by including constant-gain amplifiers and calibrated shift controls. The Y-shift control is adjusted so that positive peak of the test voltage coincides with some datum line on the screen; the shift control is then operated until the negative peak coincides with the datum. The movement of the control is arranged to read directly the peak-to-peak voltage. The value of a current can be obtained by measuring the voltage drop across a known resistance connected in the circuit.

21.14. Measurement of Phase and Frequency (Lissajous Patterns). It is interesting to consider the characteristics of patterns that appear on the screen of a CRT when sinusoidal voltages are simultaneously applied to horizontal and vertical plates. These patterns are called 'Lissajous Patterns'.

When two sinusoidal voltages of equal frequency which are in phase with each other are applied to the horizontal and vertical deflection plates, the pattern appearing on the screen is a straight line as is clear from Fig. 21.12.

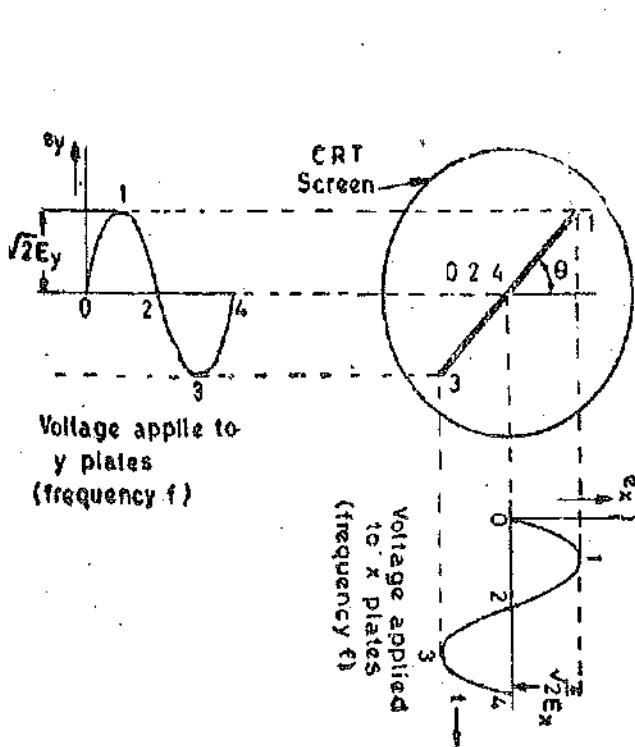

Fig. 21.12. Lissajous pattern with equal frequency voltages and zero phase shift.

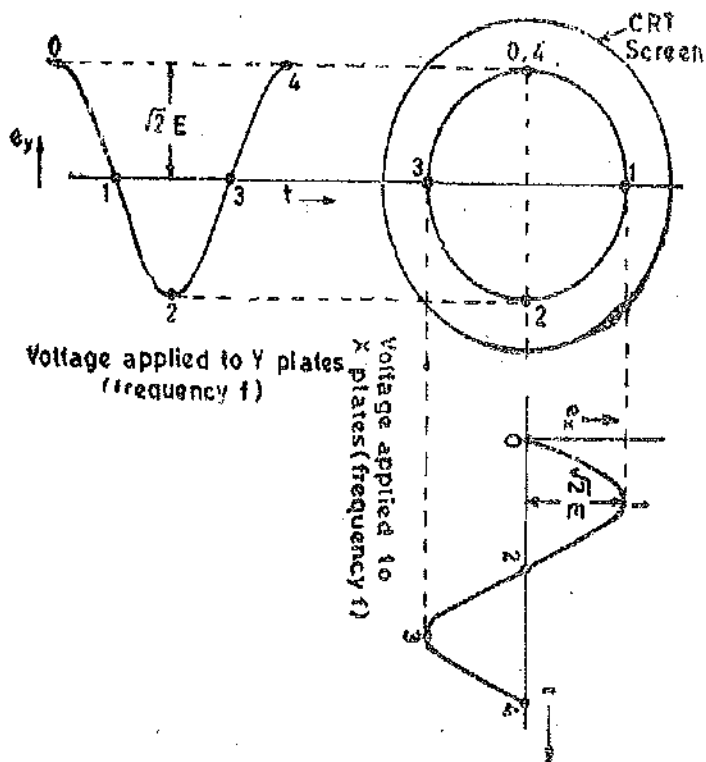

Fig. 21.13. Lissajous pattern with equal voltages of equal frequency and a phase shift of 90° .

Thus when two equal voltages of equal frequency but with 90° phase displacement are applied to a CRO, the trace on the screen is a circle. This is shown in Fig. 21.13.

When two equal voltages of equal frequency but with a phase shift ϕ (not equal to 0° or 90°) are applied to a CRO we obtain an ellipse as shown in Fig. 21'14. An ellipse is also obtained when unequal voltages of same frequency are applied to the CRO.

A number of conclusions can be drawn from the above discussions. When two sinusoidal voltages of same frequency are applied :

(i) A straight line results when the two voltages are equal and are either in phase with each other or 180° out of phase with each other. The angle formed with the horizontal is 45° when the magnitudes of voltages are equal. An increase in the vertical deflection voltage causes the line to have an angle greater than 45° with the horizontal. On the other hand a greater horizontal voltages makes the angle less than 45° with the horizontal.

(ii) Two sinusoidal waveforms of the same frequency produce a Lissajous pattern, which may be a straight line, a circle or an ellipse depending upon the phase and magnitude of the voltages.

A circle can be formed only when the magnitude of the two signals are equal and the phase difference between them is either 90° or 270° . However, if the two voltages are not equal and/or out of phase an ellipse is formed. If the Y voltage is larger, an ellipse with vertical major axis is formed while if the X plate voltage has a greater magnitude, the major axis of the ellipse lies along horizontal axis.

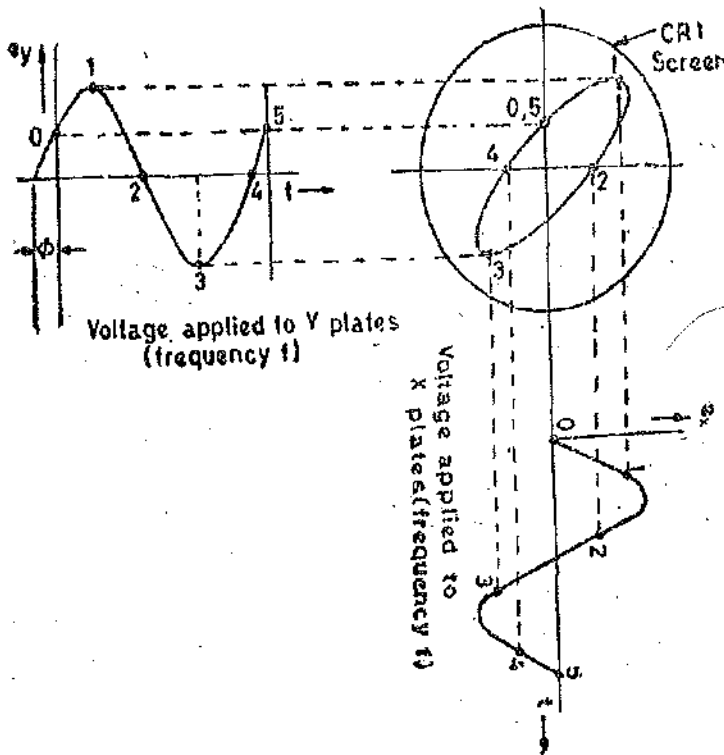

Fig. 21'14. Lissajous pattern with two equal voltages of same frequency and phase shift of ϕ .

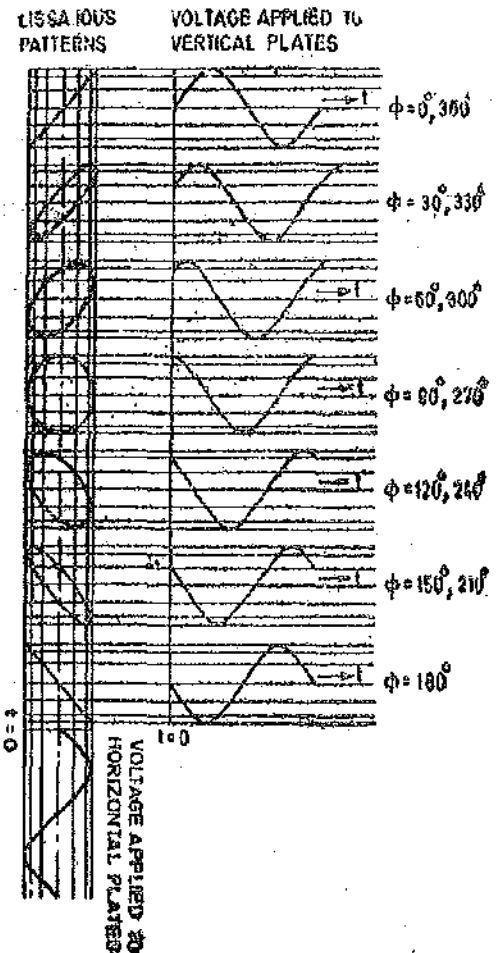

Fig. 21'15. Lissajous patterns with different phase shifts.

(iii) It is clear from Fig. 21'15, that for equal voltages of same frequency progressive variation of phase voltage causes the pattern to vary from a straight diagonal line to ellipses of different eccentricities and then to a circle, after that through another series of ellipses and finally a diagonal straight line again.

Regardless of the two amplitudes of the applied voltages the ellipse provides a simple means of finding phase difference between two voltages. Referring to Fig. 21'16, the sine of the phase angle between the voltages is given by :

$$\sin \phi = \frac{Y_1}{Y_2} = \frac{X_1}{X_2} \dots(21'21)$$

For convenience, the gains of the vertical and horizontal amplifiers are adjusted so that the ellipse fits exactly into a square marked by the lines on the graticule.

If the major axis of the ellipse lies in the first and third quadrants (*i.e.*, its slope is positive) as in Fig. 21'16 (a), the phase angle is either between 0° to 90° or between 270° to 360°. When the major axis of ellipse lies in second and fourth quadrants *i.e.*, when its slope is negative as in Fig. 21'16 (b), the phase angle is either between 90° and 180° or between 180° and 270°.

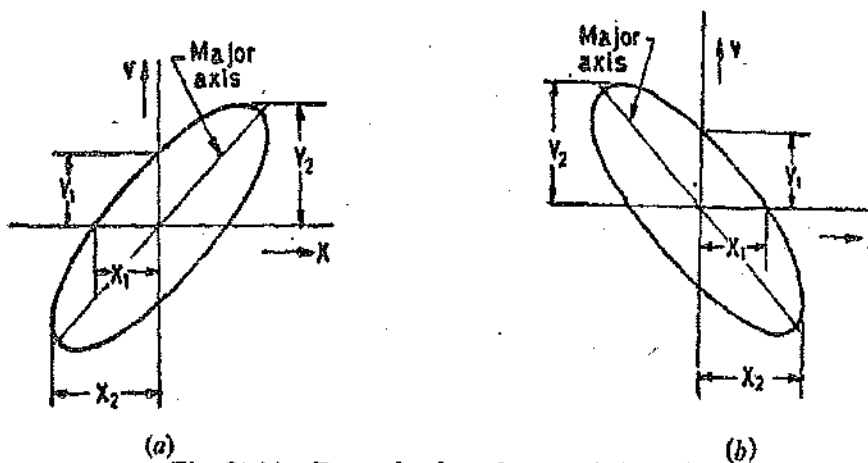

(a) Fig. 21'16. Determination of angle of phase shift. (b)

Frequency Measurements. Lissajous patterns may be used for accurate measurement of frequency. The signal, whose frequency is to be measured, is applied to the Y plates. An accurately calibrated standard variable frequency source is used to supply voltage to the X plates, with the internal sweep generator switched off. The standard frequency is adjusted until the pattern appears as a circle or an ellipse, indicating that both signals are of the same frequency. Where it is not possible to adjust the standard signal frequency to the exact frequency of the unknown signal, the standard is adjusted to a multiple or a submultiple of the frequency of the unknown source so that the pattern appears stationary.

Let us consider an example. Suppose sine waves are applied to X and Y plates as shown in Fig. 21'17. Let the frequency of wave applied to Y plates is twice that of the voltage applied to X plates. This means that the CRT spot travels two complete cycles in the vertical direction against one in the horizontal direction.

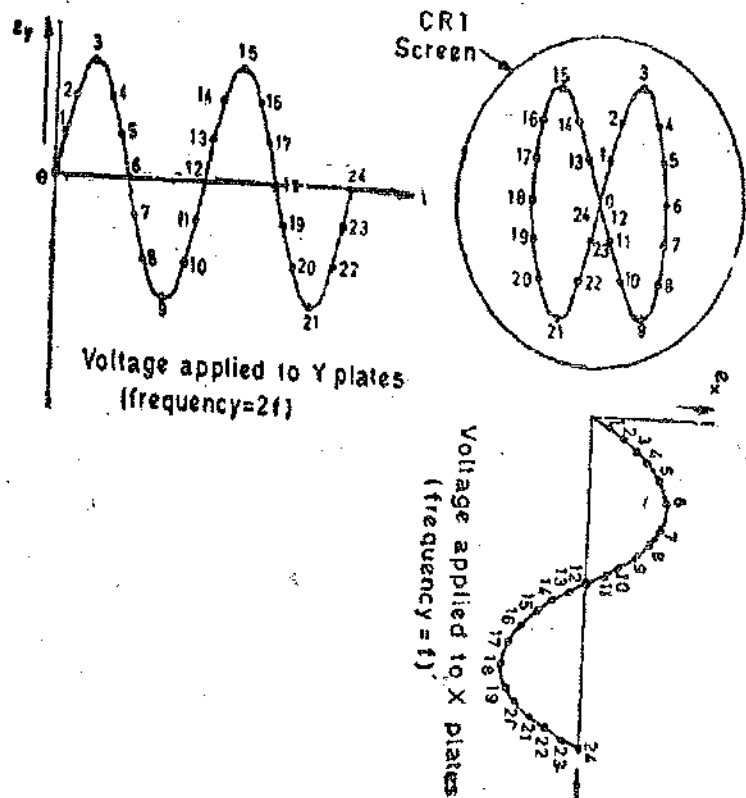

Fig. 21'17. Lissajous pattern with frequency ratio 2 : 1.

The two waves start at the same instant. Lissajous pattern may be constructed in the usual way and a 8 shaped pattern with two loops is obtained. If the two waves do not start at the same instant we get different patterns for the same frequency ratio. The Lissajous patterns for other frequency ratios can be similarly drawn. Some of these patterns are shown in Fig. 21'18.

It can be shown that for all the above cases, the ratios of the two frequencies is :

$$\frac{f_y}{f_x} = \frac{\text{number of times tangent touches top or bottom}}{\text{number of times tangent touches either side}}$$

$$= \frac{\text{number of horizontal tangencies}}{\text{number of vertical tangencies}}$$

where
and

f_y = frequency of signal applied to Y plates.
 f_x = frequency of signal applied to X plates.

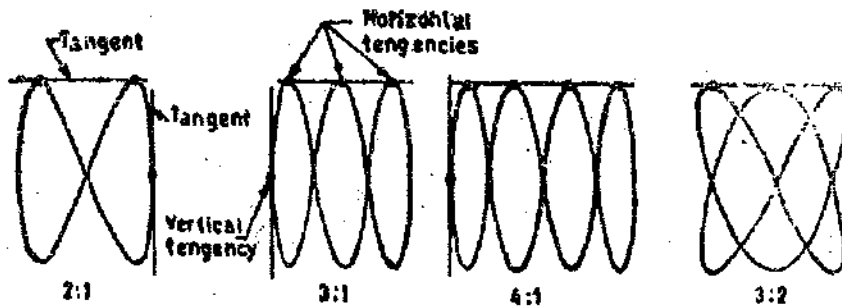

Fig. 21'18. Lissajous patterns with different frequency ratios.

The above rule, however, does not hold for the Lissajous pattern with free ends as shown in Fig. 21'19 (a). The simple rule mentioned above needs following modifications.

Two lines are drawn, one horizontal and the other vertical so that they do not pass through any intersections of different parts of the Lissajous curve. The number of intersections of the horizontal and the vertical lines with the Lissajous curve are individually counted. The frequency ratio is given by :

$$\frac{f_y}{f_x} = \frac{\text{number of intersections of the horizontal line with the curve}}{\text{number of intersections of the vertical line with the curve}}$$

The applications of this rule to Fig. 21'19 gives a frequency ratio $\frac{f_y}{f_x} = \frac{5}{2}$.

The modified rule is applicable in all cases whether the Lissajous pattern is open or closed.

The ratio of frequencies when open ended Lissajous patterns are obtained can also be found by treating the open ends as half tangencies as shown in Fig. 21'19 (b). The pattern of Fig. 21'19 (a) is reproduced.

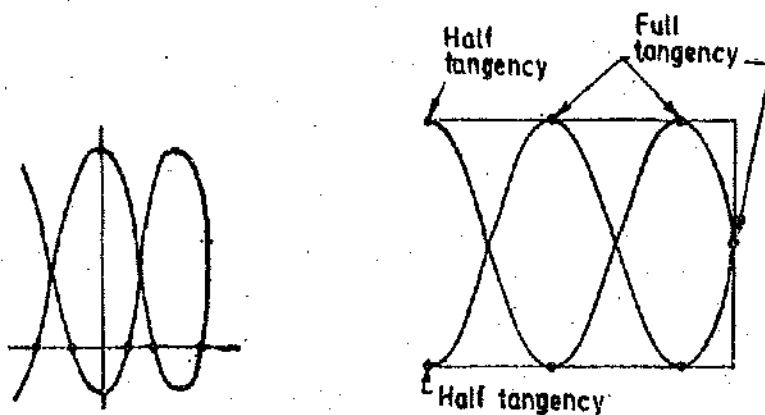

(a) $\frac{f_y}{f_x} = \frac{\text{number of horizontal tangencies}}{\text{number of vertical tangencies}}$

(b) $\frac{f_y}{f_x} = \frac{2 + 1/2}{1} = \frac{5}{2}$

There are some restrictions on the frequencies which can be applied to the deflection plates. One obviously, is that the CRO must have the bandwidth required for these frequencies. The other restriction is that the ratio of the two frequencies should not be such as to make the pattern too complicated otherwise determination of frequency would become difficult. As a rule ratios as high as 10 : 1 and as low as 10 : 9 can be determined comfortably.

21'15. Special Purpose Oscilloscopes

There are a number of types of oscilloscopes which are used for special applications. Some of these oscilloscopes are described below.

21'16. Multiple Beam Oscilloscopes. In many cases it becomes necessary to compare one signal with another. In such cases **Multiple Beam Oscilloscopes** are used. Multiple beam oscilloscopes enclose in a single tube several beam producing systems each with its vertical pair of plates, but mostly with a common time-base. Each *Y* channel has its own amplifier. The synchronization or triggering is done from the input of a desired *Y* channel or from an external input voltage.

Double Beam Oscilloscopes use two electron guns within the same cathode ray tube. The electron beams of the two channels are completely independent of each other. The same effect may be produced by a single electron gun, the output from it being split into two independently controllable electron beams.

21'17. Multiple Trace Oscilloscopes. This oscilloscope uses a single electron gun and produces multiple traces by switching the *Y* deflection plates from one input signal to another (this means that the *Y* channel is time shared by many signals). The eyes interpret this as a continuous simultaneous display of the input signals although it is a sampled display. This method reduces the cost of manufacturing multi-channel oscilloscopes.

21'18. Sampling Oscilloscopes. The oscilloscopes presently available can be used for continuous display for frequencies in the 50—300 MHz range depending upon the design of the oscilloscope. Above this range of frequencies **Sampling Techniques** must be employed to obtain satisfactory display. The display may be made up from as many 1000 dots of luminescence. The vertical deflection for each dot is obtained from progressively later points in each successive cycle of the input waveform as shown in Fig. 21'20. The horizontal deflection of the electron beam is obtained by application of a staircase waveform to *X* deflection plates.

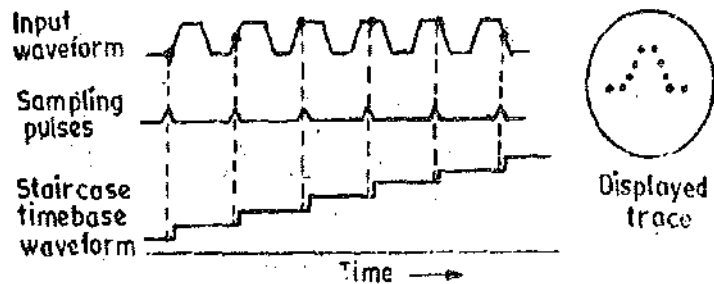

Fig. 21'20. Principle of sampling oscilloscopes.

The sampling oscilloscope is able to respond and store rapid bits of information and present them in a continuous display. It is this ability that enables the sampling oscilloscope to side-step the usual limitations in conventional high frequency oscilloscopes which have limited sensitivity and bandwidth and small display size. The sampling techniques immediately transform the input signal into lower frequency domain, where conventional low frequency circuitry is then capable of producing a highly effective display.

The sampling oscilloscopes can be used beyond 50 MHz into the UHF range around 500 MHz and beyond upto 10 GHz. However, it should be understood that sampling techniques cannot be used for the display of transient waveforms.

21'19. Impulse Waveform Oscilloscopes. These oscilloscopes are used for investigation of transient non period phenomena which occur at high voltages. These oscilloscopes use special types of CRT wherein the plates are mounted on the sides. The voltage to be measured is applied to these plates either directly or through capacitive potential dividers. Simultaneously, an impulse is suddenly applied to the cathode voltage. A very bright display is obtained on account of the high voltage and

the high beam current which exist for a very short duration. Therefore, photographic records of the display can be obtained even at very high speeds of upto 50×10^6 m/s.

21.20. Scanning Oscilloscopes. These oscilloscopes use television tubes. The data to be measured are applied through intensity modulation on the standardized screen. Several phenomena can be observed simultaneously on a single screen by using this technique.

Because of the large number of factors influencing the quality of the recording, experience with the particular camera-CRO combination is usually the best guide.

21.21. Storage Type Oscilloscope. The storage type CRO is rapidly becoming one of the most useful tools in the presentation of very slowly swept signals and finds many applications in the mechanical and biomedical fields. In the conventional CRT the persistence of the phosphor ranges from microseconds to perhaps seconds. In applications where the persistence of the screen is smaller than the rate at which the signal sweeps across the screen, the start of the display will have disappeared before the end of the display is written.

With the variable-persistence or storage CRO, the slowly swept trace can be kept on display continuously by adjusting the persistence of the CRT screen to match the sweep time. Persistence times much greater than a few seconds or even hours, are available, making it possible to store events on a CRT screen. The storage CRO uses a special CRT, called the storage tube. This special CRT contains all the elements of a conventional CRT, such as the electron gun, the deflection plates, and a phosphor screen, but in addition holds a number of special electrodes. A schematic representation of one type storage tube is given in Fig. 21.21.

The storage mesh or storage target, mounted just behind the phosphor screen, is a conductive mesh covered with a highly resistive coating of magnesium fluoride. The write gun is a high-energy electron gun, similar to the conventional gun, giving a narrow focussed beam which can be deflected and used to write the information to be stored. The write gun etches a positively charged pattern on the storage target by knocking off secondary-emission electrons. Because of the excellent insulating properties of the magnesium fluoride coating, this positively charged pattern remains exactly in the same position on the storage target where it was first deposited. The electron beam, which is deflected in the conventional manner both in the horizontal and the vertical directions, therefore trace out the waveform pattern on the storage target.

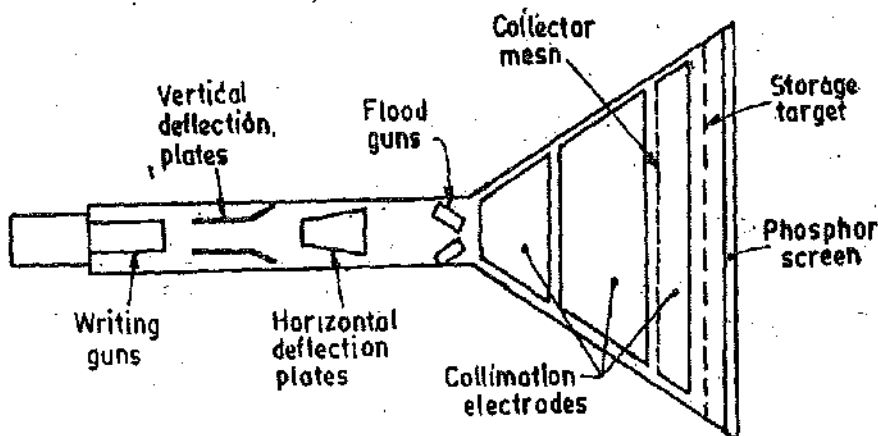

Fig. 21.21. Schematic diagram of a storage type CRT.

The stored pattern may be made available for viewing at a later time by the use of two special electron guns, called flood guns. The flood guns are placed inside the CRT in a position between the deflection plates and the storage target and they emit low-velocity electrons over a large area towards the entire screen. When the flood guns are switched on (the viewing mode), low energy electrons are sprayed towards the screen. The electron trajectories are adjusted by the collimation electrodes which constitute a low voltage electrostatic lens system, so that the flood-electrons cover the entire screen area. Most of the flood-electrons are collected by the collector mesh and therefore never reach the phosphor screen. In the area near the stored positive charge on the storage target, the positive field pulls some of the flood-electrons through the storage mesh and these electrons continue to hit the

phosphor. The CRT display therefore will be an exact copy of the pattern which was initially stored on the target and the display will be visible as long as the flood guns continue emission of low-energy electrons. To erase the pattern which is etched on the storage mesh, a negative voltage is applied to the storage target, neutralizing the stored positive charge.

To obtain variable persistence, the erase voltage is applied in the form of pulses instead of a steady d.c. voltage. By varying the width of these pulses the rate of erasure is varied. The variable-persistence control on the front panel of the scope is then the width control of the erase-pulse generator.

21'22. Accessories of Cathode Ray Oscilloscopes. The cathode-ray oscilloscope is one of the most useful instruments in the electronic industry. The usefulness of the oscilloscope is further extended by provision of accessories or auxiliary equipment. Some of the accessories are described below.

21'23. Calibrators. Many oscilloscope have a built-in reference source of voltage which has usually a square waveform with a frequency of 1 kHz. The voltage may have a single magnitude or may be of several selectable magnitudes. Provision of this facility enables the oscilloscope amplifiers and time base to be calibrated and checked for accuracy.

21'24. Probes. The probe performs the very important function of connecting the test circuit to the oscilloscope without altering, loading, or otherwise disturbing the test circuit. A probe has been described on page 651 page 640.

The probes are of three different types :

(i) Direct reading probe, (ii) circuit isolation probe, and (iii) detector probe.

1. Direct Probe. This probe is simplest of all the probes and uses a shielded co-axial cable. It avoids stray pick-ups which may create problems when low level signals are being measured. It is usually used for low frequency or low impedance circuits. However, in using the shielded probe, the shunt capacitance of the probe and cable is added to the input impedance and capacity of the scope and acts to lower the response of the oscilloscope to high impedance and high frequency circuits.

2. Isolation Probe. Isolation probe is used in order to avoid the undesirable circuit loading effects of the shielded probe. The isolation of the probe, which is used along with a capacitive voltage divider, decreases the input capacitance and increases the input resistance of the oscilloscope. This way the loading effects are drastically reduced.

3. Detector probe. When analyzing the response to modulated signals used in communication equipment like AM, FM and TV receivers, the detector probe functions to separate the low frequency modulation component from the high frequency carrier. The amplitude of the modulation carrier (which is proportional to the response of the receiver to the much high frequency carrier signal) is displayed on the oscilloscope by rectifying and bypassing action. This permits an oscilloscope capable of audio-frequency response to perform signal tracing tests on communication signals in the range of hundreds of MHz, a range, which is beyond the capabilities of all oscilloscopes except the highly specialized ones.

21'25. Cameras. The best method of permanent records of oscilloscope traces for analysis is the use of photography. Special cameras are used for the purpose and they are of the following two types :

(i) **35 mm Film.** The 35 mm unit is usually prefocused and bolted over the tube face. Some cameras have a fixed lens aperture, the exposure is simply controlled by hand operation of flapper shutter. More sophisticated arrangements use exposure and aperture control. Panchromatic and special blue sensitive films are commonly used because they are faster and hence are better suited for recording of high speed transients. Both these films give a "negative" record from which positive prints having white traces on a black background are made. Another type of 35 mm film gives a photograph which has a black trace on a white background. These films are, however, difficult to enlarge.

(ii) **Polaroid film.** This photographic technique approaches instant photography. A permanent record is obtained within 10–20 s. However, this process is much more expensive than the 35 mm photographic technique. But the relative cost may be reduced by using the facility of some of the cameras to be moved relative to the screen, making it possible to place several traces on a single print. The camera is again prefocused, but is normally provided with aperture and exposure controls. The photographic record is obtained on polaroid film which is a white trace on a black background. Since in many situations, it is the time which is much more important, the Polaroid photography is normally used under such circumstances.

21'26. Electronic Switch. The electronic switch is an extremely useful accessory for displaying two signals simultaneously on single trace oscilloscopes. The electronic switch is essentially a square wave generator. The two signals which are to be displayed are each connected to a separate grid of a dual-section amplifier tube, operating with cutoff bias. The square wave is applied in such a manner that it alternately unblanks each tube section, thereby presenting each signal alternately to the vertical amplifier of the oscilloscope. When the switching rate, which is determined by the square wave frequency, is high enough each signal appears continuous even though it is actually interrupted periodically. The switching rates may be as high as 100 kHz.

Example 21'1. Calculate the maximum velocity of the beam of electrons in a CRT having a cathode anode voltage of 800 V. Assume that the electrons to leave the cathode with zero velocity. Charge of electron = 1.6×10^{-19} C and mass of electron = 9.1×10^{-31} kg.

Solution. From Eqn. 21'5, velocity of electrons is :

$$v_{0z} = \sqrt{\frac{2e E_a}{m}} = \sqrt{\frac{2 \times 1.6 \times 10^{-19} \times 800}{9.1 \times 10^{-31}}} = 16.8 \times 10^8 \text{ m/s.}$$

Example 21'2. An electrically deflected CRT has a final anode voltage of 2000 V and parallel deflecting plates 1.5 cm long and 5 mm apart. If the screen is 50 cm from the centre of deflecting plates, find (a) beam speed, (b) the deflection sensitivity of the tube, and (c) the deflection factor of the tube.

Solution. Velocity of beam $v_{0z} = \sqrt{\frac{2 \times 1.6 \times 10^{-19}}{9.1 \times 10^{-31}}} \times 2000 = 26.5 \text{ m/s.}$

From Eqn. 21'17, deflection sensitivity,

$$S = \frac{L l_a}{2d E_a} = \frac{0.5 \times 1.5 \times 10^{-2}}{2 \times 5 \times 10^{-3} \times 2000} \text{ m/V} = 0.375 \text{ mm/V.}$$

$$\text{Deflection factor } G = \frac{1}{S} = \frac{1}{0.375} = 2.66 \text{ V/mm.}$$

Example 21'3. A CRT has an anode voltage of 2000 V and parallel deflecting plates 2 cm long and 5 mm apart. The screen is 30 cm from the centre of the plates. Find the input voltage required to deflect the beam through 3 cm. The input voltage is applied to the deflecting plates through amplifiers having an overall gain of 100.

Solution. From Eqn. 21'16, deflection $D = \frac{L l_a E_a}{2d E_0}$.

$$\therefore \text{Voltage applied to deflecting plates } E_a = \frac{2d E_0 D}{L l_a} = \frac{2 \times 5 \times 10^{-3} \times 2000 \times 3 \times 10^{-2}}{0.3 \times 2 \times 10^{-2}} = 100 \text{ V.}$$

$$\therefore \text{Input voltage required for a deflection of 3 cm} = \frac{E_a}{\text{gain}} = \frac{100}{100} = 1 \text{ V.}$$

Example 21'4. Calculate the velocity of the electron beam in an oscilloscope if the voltage applied to its vertical deflection plates is 2000 V. Also calculate the cutoff frequency if the maximum transit time is 1/4 of a cycle. The length of horizontal plates is 50 mm.

Solution. Velocity of electron beam $v_{0e} = \sqrt{\frac{2 \times 16 \times 10^{-19}}{9.1 \times 10^{-31}} \times 2000} = 26.5 \times 10^6 \text{ m/s}$

Cutoff frequency $f_c = \frac{v_{0e}}{4l} = \frac{26.5 \times 10^6}{4 \times 50 \times 10^{-3}} = 132.5 \times 10^6 \text{ Hz} = 132.5 \text{ MHz.}$

Example 21.5. Voltage E_1 is applied to the horizontal input and voltage E_2 is applied to the vertical input of a CRO. E_1 and E_2 have the same frequency. The trace is an ellipse. The slope of the major axis is positive. The maximum vertical value is 2.5 divisions and the point where the ellipse crosses the vertical axis is 1.25 divisions. The ellipse is symmetrical about the horizontal and vertical axis. Determine the possible phase angles of E_2 with respect to E_1 .

Solution. Referring to Fig. 21.16 (a), $\sin \phi = \frac{Y_1}{Y_2} = \frac{1.25}{2.50} = 0.5. \quad \therefore \phi = 30^\circ.$

Thus possible phase angles are 30° or 330° .

Example 21.6. The sketches shown in Fig. 21.22 display Lissajous patterns for cases where voltages of same frequency but of different phase are connected to Y and X plates of the oscilloscope. Find the phase difference in each case. The spot generating the patterns moves in a clockwise direction. Calculate the angles if the spot generating the patterns moves in the anticlockwise direction.

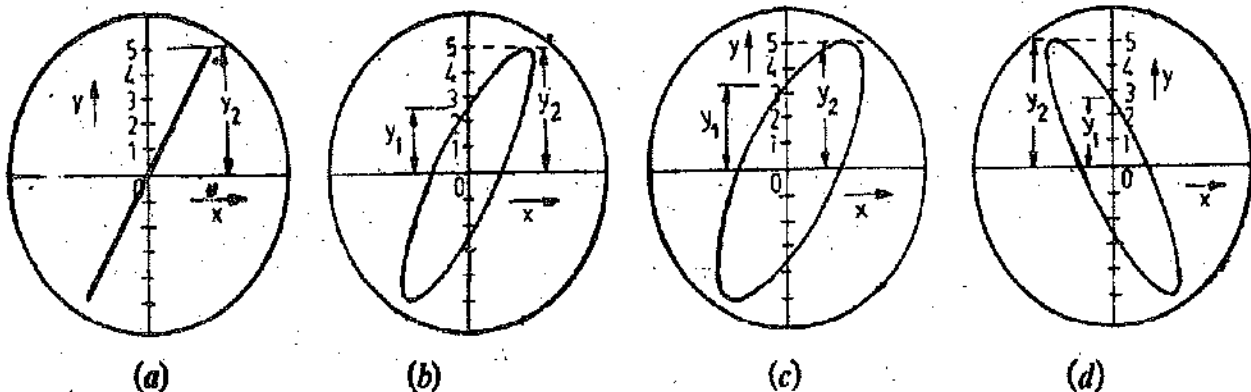

Fig. 21.22

Solution. The spot generating the patterns moves in clockwise direction.

$$(a) \quad \sin \phi = \frac{Y_1}{Y_2} = \frac{0}{5} = 0$$

$\therefore \phi = 0^\circ$ (as the Lissajous pattern is in 1st and 3rd quadrants).

$$(b) \quad \sin \phi = \frac{2.5}{5} = 0.5$$

$\therefore \phi = 30^\circ$ (as the major axis of the pattern is in 1st and 3rd quadrants).

$$(c) \quad \sin \phi = \frac{3.5}{5} = 0.7$$

$\therefore \phi = 45^\circ$ (as the major axis of the pattern is in 1st and 3rd quadrants).

$$(d) \quad \sin \phi = \frac{2.5}{5} = 0.5$$

$\therefore \phi = 180 - 30^\circ = 150^\circ$ (as the major axis is in 2nd and 4th quadrants).

If the spot generating the patterns moved in the counter clockwise direction, the angles would

(a) 180° , (b) -30° , (c) -45° , (d) $180 + 30 = 210^\circ$

Example 21'7. A Lissajous pattern on the oscilloscope is stationary and has 6 vertical maximum values and five horizontal maximum values. The frequency of horizontal input is 1500 Hz. Determine the frequency of vertical input.

Solution. The Lissajous pattern has 6 vertical maximum values and thus a horizontal line will be tangent to it 6 times. The pattern has 5 horizontal maximum values and thus a vertical line will be tangent to it 5 times.

Thus,
$$\frac{\text{vertical input frequency}}{\text{horizontal input frequency}} = \frac{f_v}{f_h} = \frac{6}{5}$$

$$\therefore \text{Vertical input frequency} = f_v = \frac{6}{5} f_h = \frac{6}{5} \times 1500 = 1800 \text{ Hz.}$$

Example 21'8. In the screen-pattern oscillograms shown in Fig. 21'23 a sine-wave signal of unknown frequency is connected to the vertical input terminals of the oscilloscope. At the same time a 60 Hz voltage is connected to the horizontal input. State the frequency of unknown signal in each case.

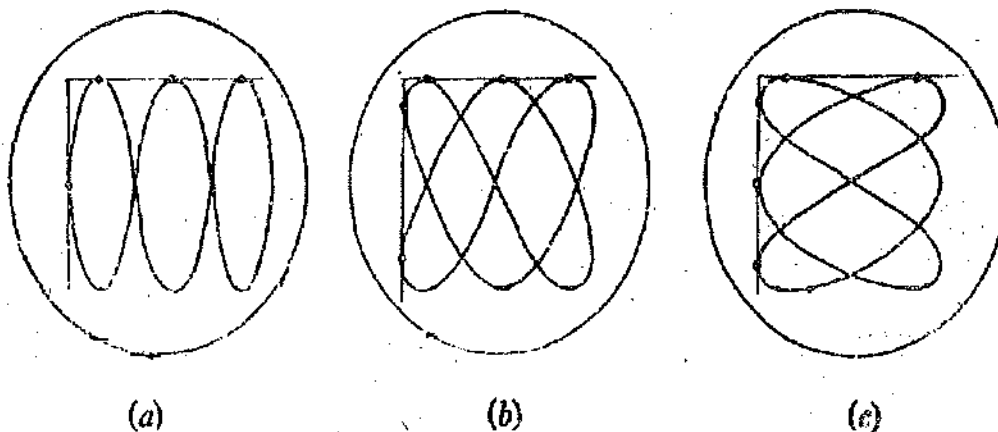

Fig. 21'23.

Solution. (a) Horizontal tangencies = 3, Vertical tangency = 1

$$\therefore \text{Unknown frequency} = f_v = 60 \times \frac{3}{1} = 180 \text{ Hz.}$$

(b) Horizontal tangencies = 3, Vertical tangencies = 2

$$\therefore \text{Unknown frequency} = 60 \times \frac{3}{2} = 90 \text{ Hz}$$

(c) Horizontal tangencies = 2, Vertical tangencies = 3

$$\therefore \text{Unknown frequency} = f_v = 60 \times \frac{3}{2} = 40 \text{ Hz.}$$

UNSOLVED PROBLEMS

1. In a cathode ray tube the distance between the deflecting plates is 1.0 cm, the length of the deflecting plates is 4.5 cm and the distance of the screen from the centre of the deflecting plates is 33 cm. If the accelerating voltage supply is 300 volt, calculate deflecting sensitivity of the tube. [Ans. 2'48 mm/V]

2. An electrostatically deflected cathode ray tube has plane parallel deflecting plates which are 2.5 cm long and 0.5 cm apart, and the distance from their centre to the screen is 20 cm. The electron beam is accelerated by a potential difference of 2500 V and is projected centrally between the plates. Calculate the deflecting voltage required to cause the beam to strike a deflecting voltage and find the corresponding deflection of the screen. [Ans. 200 V ; 4 cm]

3. Voltage E_1 is applied to the horizontal input and E_2 to the vertical input of a CRO. E_1 and E_2 have same frequency. The trace on the screen is an ellipse. The slope of major axis is negative. The maximum vertical value is 3 divisions and the point where the ellipse crosses the vertical axis is 2.6 divisions. The ellipse is symmetrical about horizontal and vertical axis. Determine the possible phase angle of E_2 with respect to E_1 . [Ans. 120° or 210°]

4. A Lissajous pattern on an oscilloscope is stationary and has 5 horizontal tangencies and 2 vertical tangencies. The frequency of horizontal input is 1000 Hz. Determine the frequency of vertical input. [Ans. 2500 Hz]

5. In the oscilloscope pattern shown in Fig. 21'24, the signal connected to the vertical plates has the same frequency in parts (a) and (b). If the input to the horizontal plates is a 50 Hz voltage :

(a) state the unknown frequency,

and (b) explain what causes the difference in appearance of two patterns.

[Ans. 25 Hz]

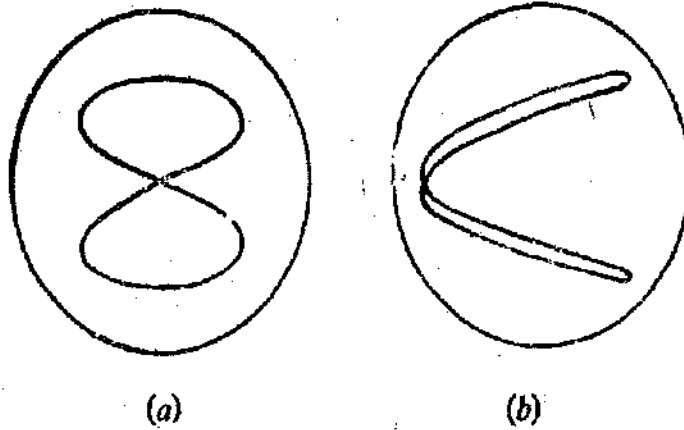

Fig. 21'24

6. Prove that the Lissajous patterns produced by voltages applied to Y and X plates as shown in Figs. 21'25(a) and (b) have the following frequency ratios.

(a) 5 : 4, (b) 8 : 1.

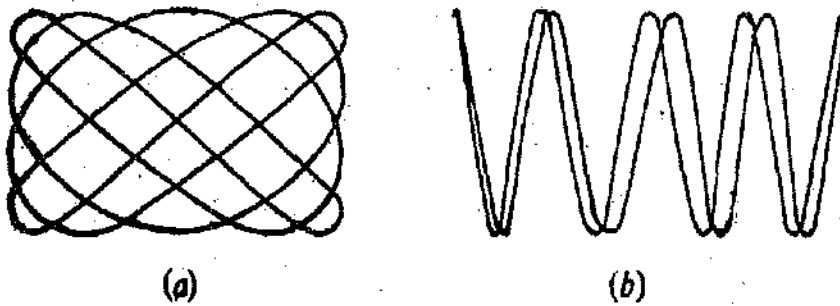

Fig. 21'25

7. Find the frequency of the vertical plates if the frequency applied to horizontal plate is 50 Hz for the patterns shown in Figs. 21'26 (a) and (b). [Ans. (a) 25 Hz, (b) 100 Hz]

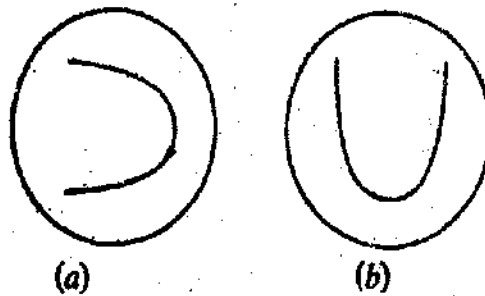

Fig. 21'26

Instruments for Generation and Analysis of Waveform

OSCILLATORS

22.1. Introduction. An oscillator is one of the most basic and useful of the electrical and electronic measuring instruments. Oscillators provide a convenient source of power or test voltage for practically all measurements. An oscillator provides a sine-wave signal output. Depending upon the oscillator design or application, terms such as oscillator, test oscillator, signal generator or function generator are used. An oscillator is the basic element of all signal sources and generates a sine wave signal of known frequency and amplitude.

The name **test oscillator** is used for an oscillator having a calibrated attenuator and an output monitor. The term **signal generator** is normally used for oscillators with modulation capacities. **Function generators** provide non-sinusoidal (pulse, square wave, triangular wave) outputs in addition to sine wave signals.

It may be understood that this terminology is not standard and different manufacturers use different names for their products and it is always desirable to check the specifications before using an instrument for any particular application.

22.2. Classification of Oscillators. Oscillators may be classified in several ways. Here they are classified on two basis :

1. the design principle used, and 2. the frequency range over which they are used.

The classification based on design principle categorises the oscillators as :

- (i) Feedback oscillators. (ii) Negative resistance oscillators.

The classification based on frequency band is :

- (i) Audio frequency (AF) oscillators : 20 Hz—20 kHz.
- (ii) Radio frequency (RF) oscillators : 20 kHz—30 MHz.
- (iii) Video frequency oscillators : d.c. —5 MHz.
- (iv) High frequency (HF) oscillators : 1.5 MHz—30 MHz.
- (v) Very high frequency (VHF) oscillators : 30 MHz—300 MHz.

Feedback Oscillators are more commonly used. They use an active device such as an amplifier whose output is feedback in phase to its input (positive feedback) to cause regenerative action resulting in oscillations.

Negative Resistance Oscillators use an active device with an inherent negative resistance characteristics which provide its own regeneration and hence oscillations.

22.3. Feedback Oscillators

A basic feedback circuit is shown in Fig. 22.1.

$$\text{Voltage gain of amplifier } G = \frac{E_0}{E_1} \quad \dots(22.1)$$

where E_1 and E_0 are phasors and G is a complex function of frequency. A portion E_f of output voltage E_0 is feedback into the input.

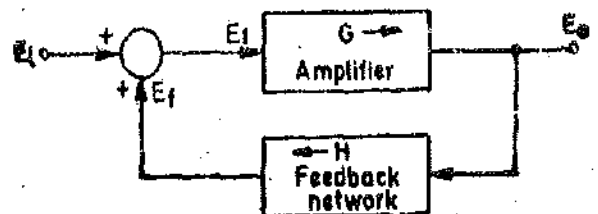

Fig. 22.1. Basic feedback circuit.

Feedback factor $H = \frac{E_f}{E_0}$... (22.2)

where H is a complex quantity.

Now amplifier input voltage E_1 is the sum of the signal E_i and feedback voltage E_f .

$E_1 = E_i + E_f$... (22.3)

Amplifier output voltage $E_0 = GE_1 = G(E_i + E_f) = G(E_i + HE_0)$

or $E_0 = \frac{GE_i}{1 - GH}$... (22.4)

∴ Gain with feedback as $G_f = \frac{E_0}{E_i} = \frac{G}{1 - GH}$... (22.5)

Eqn. 22.5 indicates that if the complex quantity GH is positive, as it approaches unity the gain increases without limit. Hence if the value of $GH = 1 + j0$, the overall gain is infinite. Physically interpreted, this situation means that the signal input voltage E_i can be reduced to zero without affecting the output voltage. Thus the amplifier can provide an output without an input and such a self-excited source is termed as a Feedback Oscillator.

In general the operating conditions for regenerative action or oscillations of feedback oscillators are :

1. The frequency of a sinusoidal feedback oscillator is determined by the condition that the loop phase shift is zero. Another way of explaining it would be that the phase shift between the amplifier input signal and the signal which is returned through amplifier and the feedback circuit must be equal to zero.

2. The product of voltage gain of amplifier, G, and the feedback factor H must be equal to or greater than 1.

22.4. Types of Feedback Oscillators. Feedback oscillators are classified into three categories :

- (i) RC (resistance-capacitance) oscillators, (ii) LC (inductance-capacitance) oscillators, and (iii) Crystal oscillators.

22.5. RC Oscillators. RC oscillators may be one of the two following forms :

- (i) Wien bridge oscillator, and (ii) Phase shift oscillator.

22.6. Wien Bridge Oscillator. The Wien bridge RC oscillator has become the standard circuit for variable frequency test circuits in the audio frequency range. This oscillator is simple and stable in operation. Also it is far less cumbersome than the LC oscillator.

Fig. 22.2 shows a Wien bridge circuit. This circuit acts as the feedback network between the amplifier input and output terminals. E_1 is the output of an amplifier which is used as an input voltage to the bridge. E_2 is the output voltage of the bridge which is feedback and becomes the input of the amplifier.

The first condition for oscillations requires that the phase shift between E_1 and E_2 be zero. This can happen only when the bridge is balanced at resonance. The analysis of a Wien bridge is given in Art. 16.22, page 517.

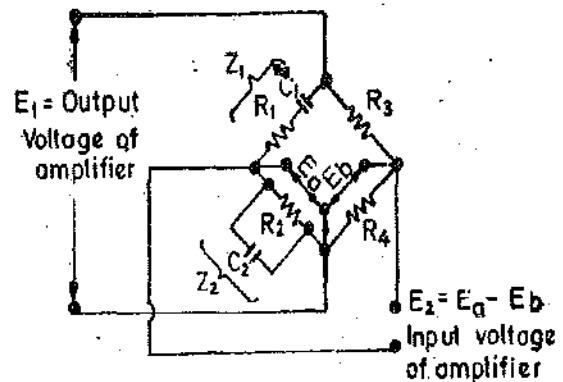

Fig. 22.2. Wien bridge circuit.

Resonant frequency $f_0 = \frac{1}{2\pi\sqrt{R_1 R_2 C_1 C_2}}$... (22.6)

If $R_1 = R_3 = R$ and $C_1 = C_2 = C$

$$\text{Resonant frequency } f_0 = \frac{1}{2\pi RC} \quad \dots(22.7)$$

Eqn. 22.7 indicates that bridge resonance is independent of the value of other two bridge arms *i.e.* R_3 and R_4 .

The second condition for oscillations requires that the product of amplifier gain, G , and the feedback factor, H , should be equal or greater than 1. As the bridge is to be used as a feedback network for the oscillator, voltage E_2 should not be equal to zero in magnitude but the phase shift between E_1 and E_2 should be zero. This means that the value of H should not be equal to zero.

The impedances Z_1 and Z_2 have the same phase angle at resonance since R_3 and R_4 are pure resistances. At resonance, therefore :

$$Z_1 = R - \frac{j}{\omega C} = (1-j)R \quad \text{and} \quad Z_2 = \frac{1}{(1/R) + j\omega C} = (1-j)\frac{R}{2}$$

$$\text{Thus } E_a = \frac{Z_2}{Z_1 + Z_2} = \frac{1}{3} E_1 \quad \dots(22.8)$$

$$\text{and } E_b = \frac{R_4}{R_3 + R_4} E_1 \quad \dots(22.9)$$

(The above relationships indicate that both E_a and E_b are in phase with E_1 at resonant frequency)

$$\text{At null point : } E_2 = E_a - E_b = 0.$$

Thus if $R_4/(R_3 + R_4) = \frac{1}{3}$ or $R_3 = 2R_4$, the output voltage E_2 will be equal to zero. We do not want to make E_2 equal to zero and therefore, the ratio, $R_4/(R_3 + R_4)$ should be smaller than $\frac{1}{3}$.

$$\text{Let } \frac{E_b}{E_1} = \frac{R_4}{R_3 + R_4} = \frac{1}{3} - \frac{1}{\alpha} \quad \text{where } \alpha > 3.$$

$$\text{Then } H = \frac{E_2}{E_1} = \frac{E_a - E_b}{E_1} = \frac{E_1}{E_1} \left(\frac{1}{3} - \frac{1}{\alpha} \right) \quad \dots(22.10)$$

At resonant frequency $E_1/E_1 = \frac{1}{3}$ and hence $H = 1/\alpha$.

Thus if the gain, G , of the amplifier is made equal to α , the condition $GH = 1$ is satisfied.

It is clear from above that :

(i) The frequency of oscillations is equal to the resonant frequency f_0 .

(ii) At any frequency other than resonant frequency E_a is not in phase with E_1 and therefore $E_2 = E_a - E_b$ is not in phase with E_1 . Thus the condition for oscillations that E_2 be in phase E_1 is satisfied only at resonant frequency.

(iii) The relationship $GH = 1$ is satisfied only at resonant frequency.

Capacitors, C , are variable air capacitors mounted on the same shaft. Continuous variation of frequency is accomplished by varying the value of C . Resistors R are provided with switches, so that different frequency ranges may be selected.

In order that the amplitude of oscillations be held steady over a wide range of frequencies, a negative feedback is necessary. This negative feedback is provided by resistors R_1 and R_2 . Resistance R_2 is often a temperature sensitive resistor with a positive resistance temperature co-efficient. R_2 is usually an incandescent lamp operated at a temperature lower than its illumination level. Since the resistance of the lamp changes with amplitude of driving signal, thus changing the voltage division of the bridge arms accordingly. Thus, as the amplitude of the oscillations increases, the resistance R_2 increases. This reduces the negative feedback which reduces the gain of the amplifier and thus amplitude of oscillations is restored to normal.

The above statement may be elaborated further as under :

The amplitude of oscillations depends upon how much the value of GH is greater than unity. If the feed backfactor H is constant, the amplitude is determined by the value of gain, G of the

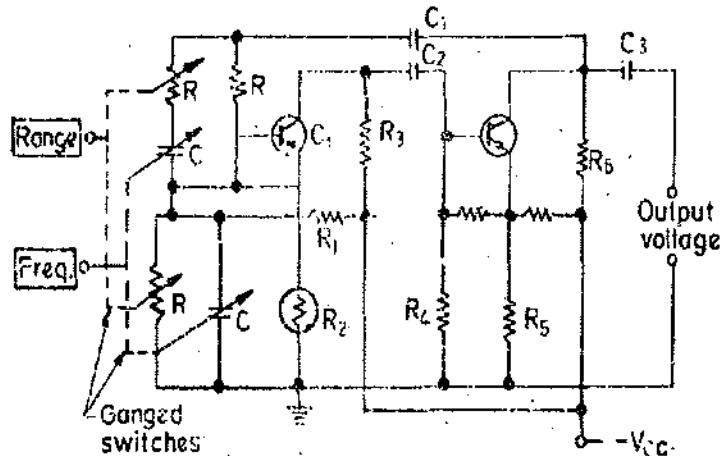

Fig. 22.3. Practical Wien bridge circuit.

amplifier. If G increases, the amplitude increases till the increase is limited by the non-linear characteristics of transistors. If the output of the amplifier tends to increase, the increased current through R_2 increases its resistance. This reduces the value of H and would then tend to keep the value of product GH constant. Thus the amplitude is regulated.

A vacuum tube Wien bridge oscillator depends upon a temperature sensitive element R_2 . This allows the operation of the amplifier within its linear region of its transfer characteristics. Thus we get a low distortion sinusoidal output. However, when using transistors, a peak detector circuit is used to provide negative feedback signal proportional to the output voltage. This is because the current drawn by an incandescent lamp is too much of a drain on the power supplies and thus is incompatible with the transistors and battery power sources. Also the use of an incandescent lamp causes a thermal lag.

Advantages

(i) The Wien bridge oscillator provides a stable low distortion sinusoidal output voltage over a wide range of frequency.

(ii) The frequency range can be selected by using simple decade resistance boxes.

(iii) The frequency of oscillations in an RC network is $f_0 = 1/2\pi RC$. Thus unlike $L-C$ networks where the resonant frequency varies inversely as square root of C , the frequency of Wien bridge oscillator varies inversely as C itself. Thus frequency variation greater than 10 : 1 is possible with single sweep of an air dielectric tuning capacitor.

(iv) With the addition of a power amplifier to isolate the oscillator from the load, the circuit is used to provide test signals for a variety of applications.

(v) The range of this oscillator is 2 Hz to 100 kHz. The upper frequency limit is fixed by the amplitude and the phase shift characteristics of the amplifier. The lower limit of frequency is fixed by the practical limits on the size of range selecting resistors.

22.7. Practical Circuit of Wien Bridge Oscillator. Fig. 22.3 shows the circuit diagram of a two stage Wien bridge oscillator. Two stages are necessary in order to obtain a phase shift of 0° as a single stage amplifier shifts by 180° . The four arms of the Wien bridge are :

(i) R and C in series (ii) R and C in parallel, (iii) resistor R_1 and (iv) resistor R_2 .

Q_1 and Q_2 are two transistors and the positive feedback is applied from the collector of Q_2 through the coupling capacitor C_1 to top of the bridge circuit.

22.8. Phase Shift Oscillator. When an audio-frequency (AF) oscillator is to be used over comparatively a limited frequency range, or on a specified frequency, simplified RC networks are usually employed. For example Fig. 22.4 shows a simple "phase shift oscillator", which can be used for generation of sinusoidal voltages upto a frequency range of several hundred kHz. The circuit consists of a single transistor amplifier stage, followed by three cascaded arrangements of resistor R and capacitor C to provide the necessary positive feedback.

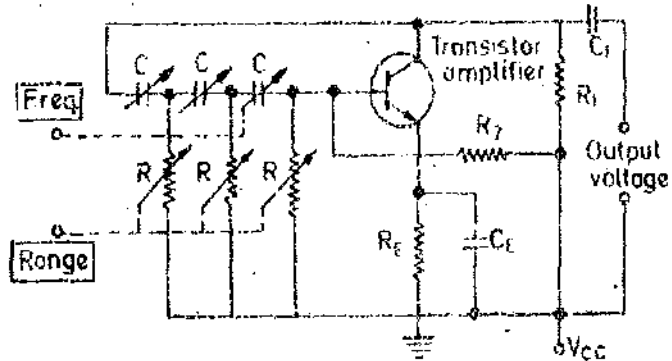

Fig. 22.4. Phase shift oscillator.

The single transistor amplifier shifts the phase of any voltage by 180° which appears at its base. The RC network is necessary to provide an additional phase shift of exactly 180° . This additional phase shift is obtained from the RC network only at a specific frequency. Hence, at a frequency where the RC network provides exact 180° phase shift, the total phase shift from the base of transistor, around the circuit, back to the base is exactly 0° . Thus the feedback voltage is in phase with the voltage input to the amplifier at that frequency. Thus, if the amplification of the transistor is sufficiently large, the circuit will act as an oscillator at that frequency.

Advantages and Disadvantages. (i) The circuit of a phase-shift oscillator is much simpler than the Wien bridge circuit. This is because this circuit dispenses with the negative feedback and the stabilization arrangements.

(ii) The phase shift oscillator may be used over a wide frequency range, from a few Hz to several kHz. The upper frequency range is limited since at high frequencies, the impedance of phase shifting RC network becomes very small, with the result the amplifier is heavily loaded. To offset this, corrective measures have to be taken which complicate the circuit and thus the advantage gained on account of simplicity of the circuit is lost.

(iii) The circuit is particularly suited for low frequencies, say of the order of 1 Hz, since these frequencies can be obtained easily from the circuit by using large values of R and C which are commercially available.

(iv) The phase shift oscillator has decidedly an advantage over L-C tuned oscillators in the low frequency range as in this frequency range the large inductors required are cumbersome and impracticable.

(v) The output obtained is purely sinusoidal.

22.9. L-C Oscillators. The first oscillators were the L-C variety. These oscillators are particularly suited for the radio frequency (R-F) range. There are many types of L-C oscillators and they use a conventional type of L-C tank circuit. Their principle of operation is simple and almost similar for any of the many variations of the basic circuit. The operation of the basic circuit is as follows:

An L-C oscillator uses a tank circuit which comprises of an inductor L in parallel with a capacitor C . The parallel combination of L and C is excited into oscillations and the output voltage of the tank circuit is amplified by either a transistor or a vacuum tube amplifier. A fraction of the amplified voltage is fed back into the tank circuit by either an inductive or a capacitive coupling. This is done in order to compensate for the power loss in the tank circuit. This "regenerative feedback" results in a constant amplitude output voltage at the resonant frequency of the tank circuit. The resonant frequency of the tank circuit is $f_0 = 1/2\pi\sqrt{LC}$.

It is evident from the expression for f_0 that these circuits are particularly suited for radio

frequencies since the value of inductance required to produce oscillations is quite small at these frequencies. The *L-C* oscillators can operate at very high frequencies, up to several hundred MHz.

22.10. Armstrong Oscillator. Fig. 22.5 shows the basic circuit of an Armstrong oscillator. Inductor, L_1 and capacitor, C_1 form the tank circuit of the oscillator. Coil L_1 is inductively coupled to a coil L_2 . When the plate supply voltage E_{bb} is first connected, current flows through the plate circuit. This current flows through coil L_2 and since L_2 is inductively coupled to coil L_1 , a voltage is induced in the later. This voltage is in such a direction that grid of the tube is driven positive. This increases the plate current at a faster rate and the induced voltage in coil L_1 increases further. Thus a high positive voltage is built up across the tank circuit. Capacitor C_1 charges with a positive polarity on its top plate. During this process, since the grid is positive the grid current charges the capacitor C_g to the peak value with a polarity as shown. As the plate current approaches its saturation point the rate of rise of plate current decreases and therefore the induced voltage decreases. Capacitor C_g , therefore, discharges through resistance R_g . This makes the grid negative and therefore a chain reaction is set off.

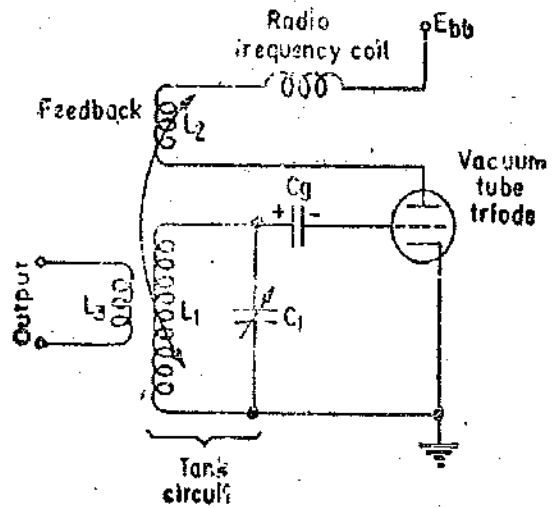

Fig. 22.5. Armstrong oscillator circuit.

As the plate current approaches its saturation point the rate of rise of plate current decreases and therefore the induced voltage decreases. Capacitor C_g , therefore, discharges through resistance R_g . This makes the grid negative and therefore a chain reaction is set off.

With the grid becoming negative, the plate current starts decreasing and as a result the magnetic field of L_2 is wiped out. This induces a negative voltage in coil L_1 . The capacitor, C_g is still discharging and this drives the tube to a cutoff region and therefore the plate current becomes zero. The negative induced voltage across L_1 causes C_1 to discharge and then charge up again to the peak value of the negative induced voltage.

The tube is cut-off and C_1 is charged with a negative polarity at its top plate. During the next half cycle, the tank circuit takes out the tube from its cut-off region. C_1 starts to discharge through L_1 and the grid is raised in potential till the tube starts conducting again. As soon as the tube conducts, the energy is transferred from the plate circuit to the tank circuit. Capacitor, C_1 , charges up again to the peak value of the positive voltage. The entire cycle repeats itself as described earlier. The output is taken from coil L_3 which is inductively coupled to coil L_1 .

22.11. Hartley Oscillator. Fig 22.6 shows the transistorized version of a Hartley oscillator. This circuit uses only one coil instead of two coils as Armstrong circuit. The coil has a tap which corresponds to the common a.c. ground of the Armstrong circuit. The variable (tuning) capacitor C_1 is now in parallel with the entire coil L_1+L_2 . The output is now available through an *RC* coupling instead of an inductive coupling as in Armstrong circuit.

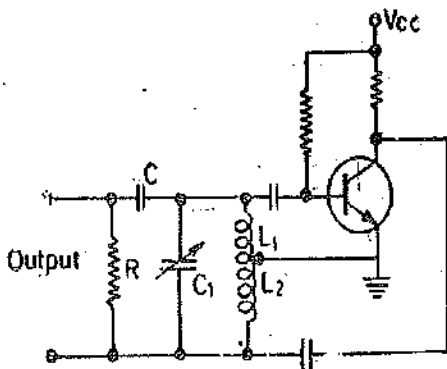

Fig. 22.6. Hartley oscillator.

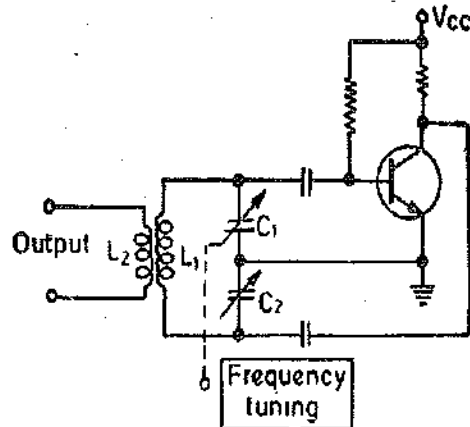

Fig. 22.7. Colpitts oscillator.

22.12. Colpitts Oscillator. The Colpitts circuit in its transistorized form is shown in Fig. 22.7. It is, in fact, another form of basic Armstrong circuit. The tank circuit consists of a fixed

inductor L_1 , and two variable capacitors C_1 and C_2 in series. This circuit differs from the Hartely's circuit only in the form of tapping. In the Hartely's circuit, the inductor is tapped while in the Colpitts circuit, the tapping is from the capacitors. The capacitors C_1 and C_2 are ganged. The amount of feedback depends upon the relative values of C_1 and C_2 . The smaller the C_1 the greater the feedback. As the tuning is varied, the values of both capacitors increase or decrease simultaneously, but the ratio of the two capacitances remains the same.

22.13. Crystal Oscillators. In crystal oscillators, the usual electrical resonant circuit is replaced by a mechanically vibrating crystal. These crystals exhibit Piezo-electric properties, *i.e.* when mechanical stresses are applied on the opposite faces of the crystal, electrical charges appear at some other faces and *vice-versa*. Thus when an alternating voltage is applied to appropriate faces, mechanical vibrations are produced at some other faces. Therefore if the frequency of alternating voltage is equal to the frequency of mechanical vibrations, the vibrations will be intense.

Piezo-electric properties are exhibited by a number of natural crystal substances like quartz, Rochelle salt, etc. Quartz is the normally used material for crystal oscillators because of its frequency control in oscillators which comes from its permanence, low temperature co-efficient and high mechanical Q . Quartz is preferred to Rochelle salt on account of the above-mentioned qualities even though Quartz has a lesser Piezo-electric effect.

The electrical equivalent of a crystal is shown in Fig. 22.8 (b). The circuit has two resonant frequencies

$$(i) \text{ Series resonant frequency } f_1 = \frac{1}{2\pi} \sqrt{\frac{1}{LC}}$$

$$(ii) \text{ Parallel resonant frequency } f_2 = \frac{1}{2\pi} \sqrt{\frac{1+C/C'}{LC}}$$

It is apparent that f_2 is greater than f_1 . But the value of ratio C/C' is very small and hence the two frequencies f_1 and f_2 are close to each other.

Because of the close analogy between a crystal and an LC network, the crystal oscillator designs are similar to those of LC oscillators. Fig. 22.9 shows the circuit of a Pierce oscillator. This circuit is similar to that of the Colpitts oscillator.

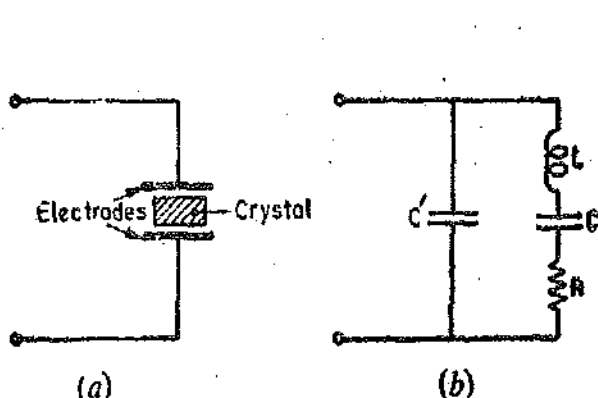

Fig. 22.8. Crystal and its equivalent electric circuit.

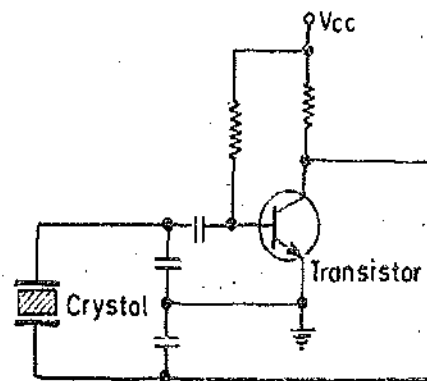

Fig. 22.9. Crystal oscillator circuit.

Advantages and Disadvantages. (1) The frequency stability of the oscillations obtained from a crystal vary and that too over a long period of time.

(2) The frequency of oscillations generated by other RF oscillators using electrical resonating (tank) circuits is effected considerably by changes in supply voltage, load and temperature. Crystal oscillators do not face these problems and thus their frequency stability is high. Hence these oscillators are the standard means of maintaining frequency.

(3) The vibrating crystal structure has a high value of Q . Values in excess of 20,000 are always to be expected and values over 1,000,000 have been obtained under special circumstances.

(4) Since the ratio of capacitance C/C' is very small, the coupling between crystal resonator and external circuit is inherently small.

(5) The crystal oscillators have a very limited tuning range (or not at all). The crystal oscillators are used for frequencies greater than 100 kHz. Their use is mainly at radio frequencies (RF).

22.14. Beat Frequency Oscillator (B.F.O.). Before the advent of the Wien bridge oscillator, the beat frequency oscillator was the most commonly oscillator to obtain variable frequency output in the audio frequency (AF) range. Now the use of B.F.O. has decreased. It is mostly used when it is desired to cover a very large frequency range with a single dial rotation (without the need for switching bands).

A beat frequency oscillator circuit is shown in Fig. 22.10 in block diagram form. One of the oscillators generates a fixed frequency and the other a variable frequency. The outputs of these oscillators are fed to a mixer. The frequency of output of the mixer is the difference of the two frequencies. Thus if the fixed frequency oscillator generates a frequency of 100 kHz and the variable frequency oscillator has a frequency range of 100 kHz to 120 kHz, the output frequency varies between 0 to 20 kHz. Therefore, frequency dial is marked 0 to 20 kHz (i.e., the difference of the two frequencies). This then is an audio frequency (AF) output. This output is amplified by an AF amplifier.

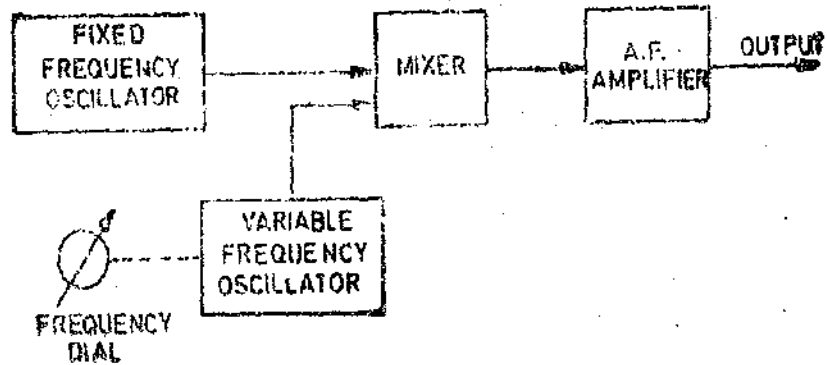

Fig. 22.10. Beat frequency oscillator,

It is obvious that circuit of a B.F.O. is much more complicated than that of a Wien bridge oscillator and hence B.F.O. is becoming obsolete.

22.15. Negative Resistance Oscillators. Many negative resistance elements are available for use in negative-resistance oscillators. These are tetrodes, tunnel diodes, neon tubes, and unijunction transistors. There are two types of negative resistance oscillators used in practice.

(i) **Dynatron.** Its action is based upon the negative resistance region of the characteristics of a tetrode coupled with an LC tank circuit.

(ii) **Tunnel Diode Oscillator.** This is solid state equivalent of the dynatron with additional advantages of very high speed operation. Therefore this oscillator is very useful in the very high frequency (VHF) and ultra high frequency (UHF) ranges.

Fig. 22.11 (a) shows the characteristics of a tunnel diode. The characteristics are stable if driven by a voltage source. The voltage current response can be used to cause or sustain oscillations. The load lines as shown are unstable; that is there are two stable intersections and one unstable intersection. If the tunnel diode is connected to an impedance which may be represented by $Z=R+jX$, we find that the criteria for instability is: $R+R_D=0$. Thus the device resistance, R_D , must cancel out the resistance of the remainder circuit, and the reactance at the frequency of oscillations must be zero. In order to obtain sinusoidal oscillations, the above conditions must be satisfied. If the resistance of the device (tunnel diode) were linear, there would be no limit to the amplitude of the oscillations. The amplitude of the oscillations can be controlled, if the positive resistance line is almost tangent to the negative resistance line. The negative resistance will then have an average value over one complete cycle which is equal to positive resistance.

The tunnel diode, which has a negative resistance, is very useful as it may operate at very high frequencies. It has been difficult to obtain high frequency operation of transistors because of

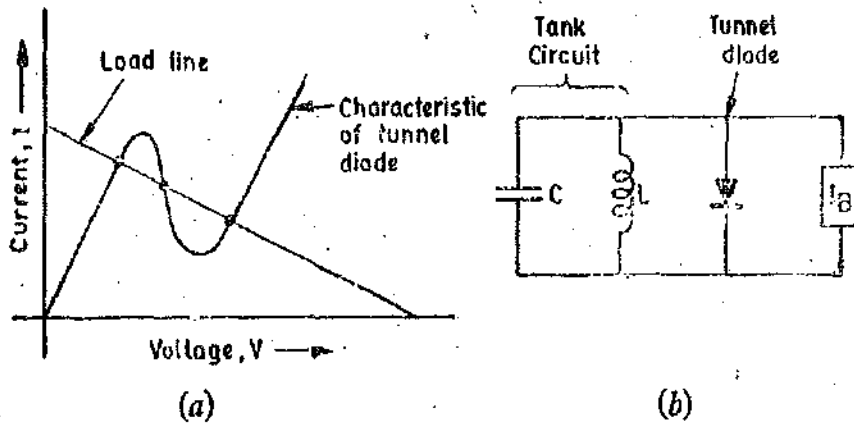

Fig. 22.11. Characteristics and circuit of a tunnel diode oscillator.

the difficulty of making thin base regions and because of the relatively slow motion of minority carriers in semi-conductors. Frequencies of the order of 100 to 500 MHz are the upper limit. The tunnel diode operates because of majority carriers and is thus very fast. It is possible to make tunnel diode oscillators which operate in the microwave frequency region. A very simple circuit as shown in Fig. 22.11 (b) can be made to oscillate if the correct bias current is applied to the tunnel diode. The tunnel diode circuits may use negative feedback for bias stability, just as feedback oscillators do.

SIGNAL GENERATORS

22.16. Standard Signal Generator. It is a source of sine wave voltage with an appreciable range of frequency and amplitude both of which are known to a high degree of accuracy. The instrument is provided with means of modulating the carrier frequency which is indicated by the dial setting. The modulation is indicated by a meter. Modulation may be done by sine wave, square wave, triangular wave or a pulse. The output signal may be amplitude modulated (AM) or frequency modulated (FM). Usually amplitude modulation is employed.

A basic block diagram of a standard signal generator is shown in Fig. 22.12. The carrier frequency (sinusoidal) is produced by a very stable RF oscillator using LC tank circuit. The frequency of oscillations is indicated by frequency range control and the vernier dial setting. Amplitude modulation is provided by either an internal or an external fixed frequency oscillator. Modulation is done in the output amplifier circuit. This amplifier delivers its output (*i.e.*, the modulated carrier) to an attenuator. The output voltage is read by an output meter and the attenuator output setting.

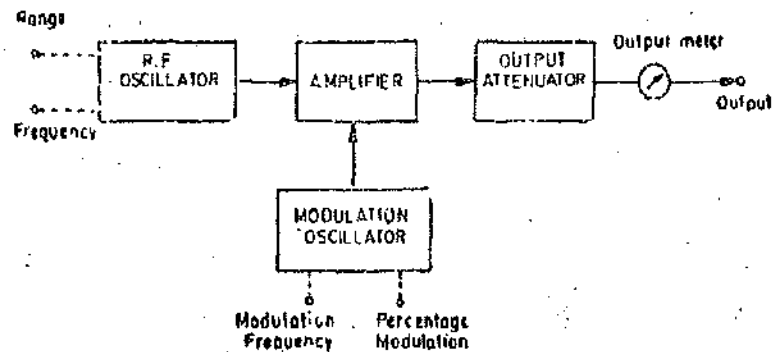

Fig. 22.12. Basic block diagram of a standard signal generator.

Modern laboratory type signal generators incorporate certain features.

The frequency stability of the oscillator must be high at all frequency ranges. Frequency stability depends upon the constancy of the supply voltages, and therefore regulated power supplies are used. In order to maintain stability, temperature compensation devices must be used.

In high frequency oscillators it is essential to isolate the oscillator circuit from the output circuit. This isolation is necessary in order that the changes which occur in the output circuit do not affect the oscillator frequency, amplitude and distortion characteristics. Buffer amplifiers may be employed for this purpose.

Fig. 22.13 shows the basic diagram of a laboratory type signal generator. A master oscillator is used which is optimally designed for highest frequency range. The RF oscillator output after

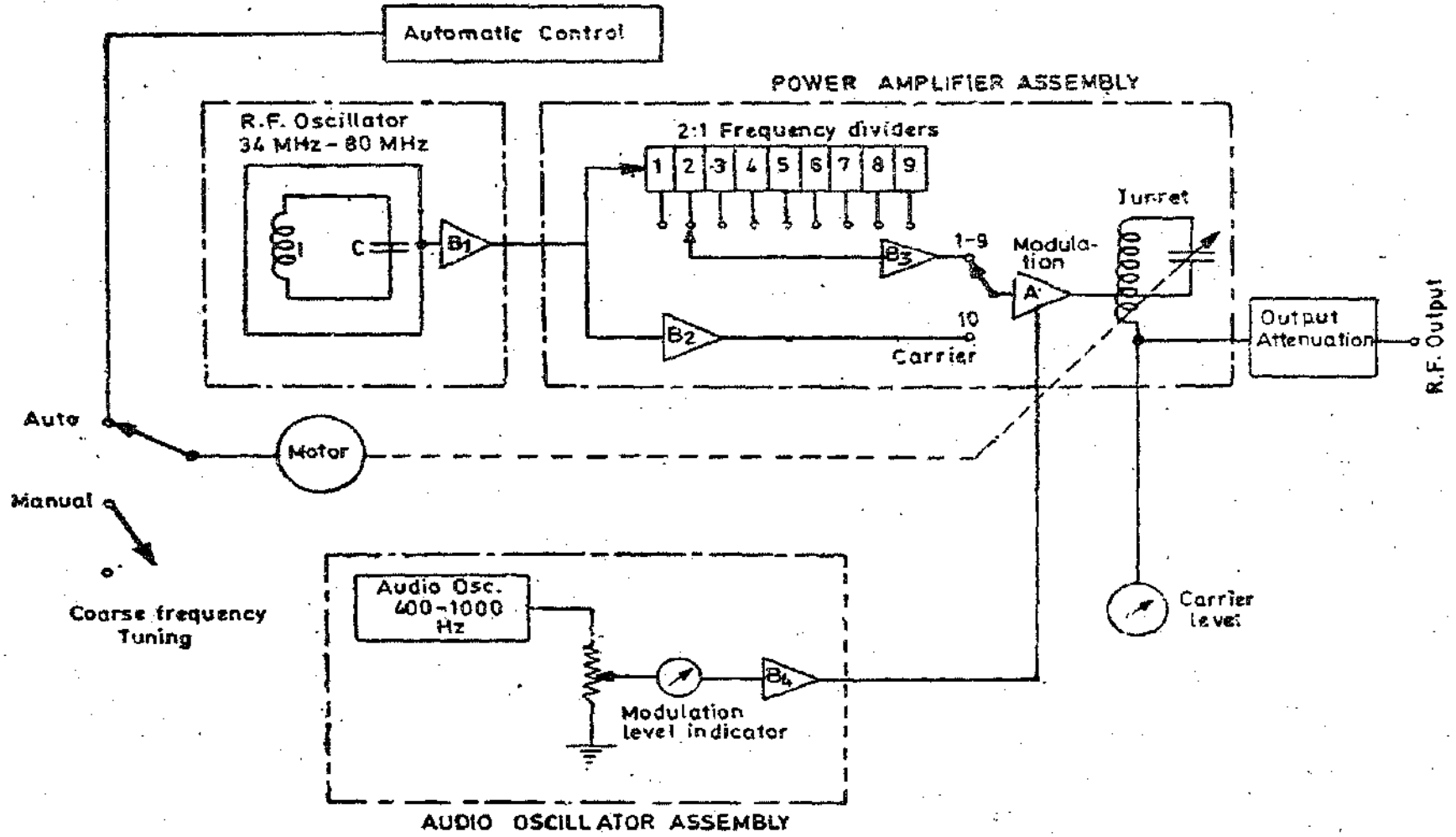

Fig. 22'13. Standard signal generator.

passing through an untuned buffer amplifier, B_1 , enters the power amplifier circuit. On the highest frequency range, which may be 34 MHz–80 MHz, the RF output passes through an additional buffer amplifier B_2 . In order to obtain lower frequencies, the RF signal is applied to series of frequency dividers. Fig. 22.13 shows 9 frequency dividers of 2 : 1 ratio. Thus a frequency ratio of 2 : 1 i.e., 512 : 1 is obtained. Thus on the lowest frequency range we get an output of 67 kHz to 156 kHz. The frequency stability of highest frequency range is imparted to the lower frequency ranges.

The master oscillators have both automatic and manual controllers. With controls driven by motor, remote automatic tuning can be done. Also it becomes a programmable automatic frequency control device.

The modulation is done at the power amplifier stage. For modulation, two internally generated signals are used. They have frequencies of 400 Hz and 1 kHz. Modulation level may be adjusted upto 95 per cent by a control device.

The signal generator is also provided with a 1 MHz crystal oscillator for calibration purposes.

SQUARE WAVE GENERATORS

22.17. Types of Circuits. There are two types of circuits which are used for square wave shapes :

- (i) **Passive.** These circuits incorporate wave shaping devices.
- (ii) **Active.** These circuits actually generate the square wave shape.

22.18. Passive Square Wave Generators. The production of square waves can be conveniently obtained from the output of a sine-wave generator. Therefore, both sine as well square wave outputs are made available in many commercial instruments.

The oscillator generator generates a sine wave output. The sine wave may be shaped into square wave by many methods. The three important methods are :

- (i) Diode clipping circuit, (ii) Overdriven amplifier, and (iii) Schmitt trigger.

22.19. Diode Clipping Circuit. A simple diode clipping circuit is used for low level outputs. A diode clipping circuit produces an approximate square wave by shaping an input sine wave. In order to produce a single peak amplitude of say 6 V, with an ordinary diode D_1 as shown in Fig. 22.14 (a), a biasing battery is used so that the input sine wave rises sinusoidally to a 6 V value before the diodes conduct to prevent any further rise in the wave in the forward direction during positive half of the cycle.

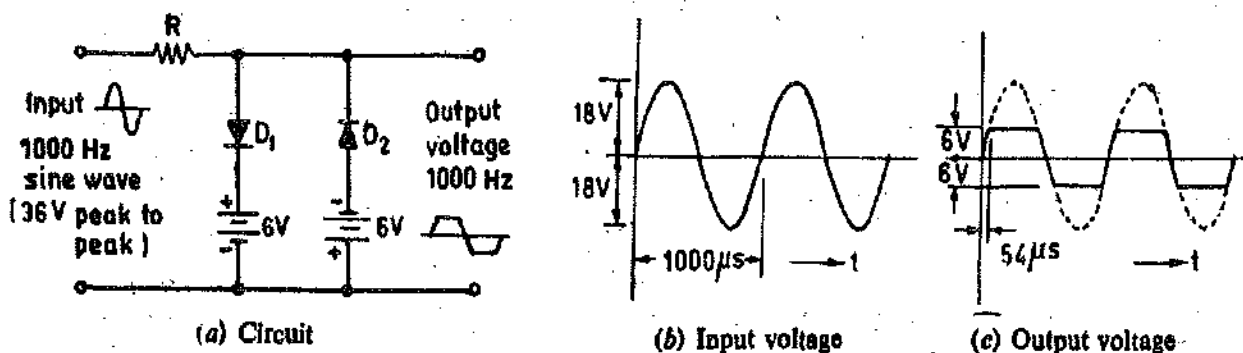

Fig. 22.14. Simple diode clipping circuit for square wave generation.

A similar diode D_2 and a 6 V biasing battery is used for performing the same function during

the negative half cycle.

A much simpler method uses two Zener diodes connected back to back as shown in Fig. 22'15. Suppose the Zener diodes have a breakdown voltage of 6 V. In this case, there is no diode conduction in either of the wave cycles of the sine wave till the sinusoidal voltage rises to 6 V. Thus, in both the cases, *i.e.* for simple diodes with 6V bias and with Zener diodes having a breakdown voltage of 6 V, an approximate square wave output with a peak-to-peak voltage of 12 V is produced from a 36 V peak-to-peak sine wave input as shown in Fig. 22'14.

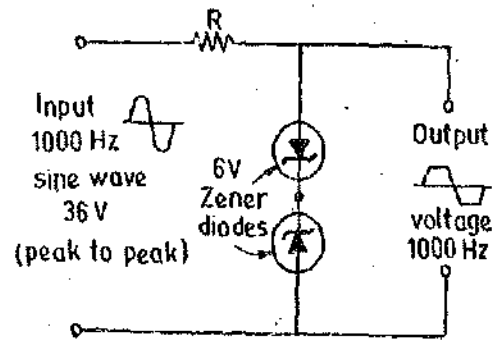

Fig. 22'15. Clipping circuit using Zener diodes connected back to back.

The diode clipping circuit has the advantage of simplicity. However, the output of the passive circuit is small and the rising and falling portions of the output wave are rather slanted instead of being vertical. In a perfect square wave, the rise time is equal to zero, however, in the case illustrated the rise time is 54 μ s. Although, such a rise time may be acceptable for some applications where only an approximate square wave is required, it must be compared with rise time of only 1 μ s and less, for cases where the squareness of the wave and the corresponding fast rise time are important

An almost perfect square wave may be obtained by using a series of clipping circuits and amplifiers as shown in Fig. 22'16. The sine wave is clipped and amplified. The amplified clipped wave is clipped again by a second clipping circuit. This way an almost square wave is obtained.

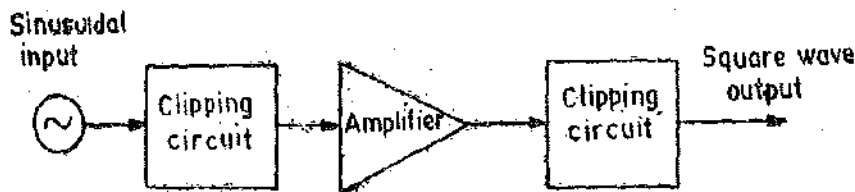
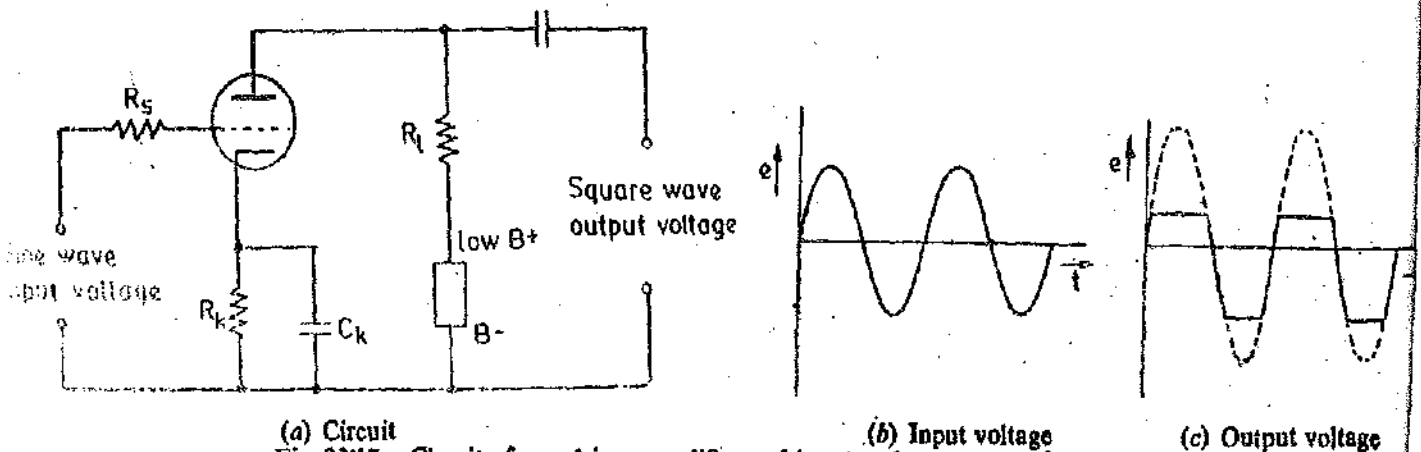

Fig. 22'16. Functional diagram of a passive square wave circuit.

22'20. Overdriven Amplifier Circuit. The use of overdriven amplifiers gives a square wave of greater amplitude. The amplifier is overdriven by a sine wave of desired frequency. The circuit for an overdriven amplifier using a vacuum tube triode is shown in Fig. 22'17 (a).

The circuit uses a series grid resistor R_s and low grid bias. The output corresponding to positive half cycle is flattened almost completely by the flow of grid current. For the negative half cycle of the sine wave, the output becomes flattened as soon as the cut off point is reached as shown in Fig. 22'17 (c).



(a) Circuit
Fig. 22'17. Circuit of overdriven amplifier and input and output waveforms.

Thus the resulting waveshape has a similar appearance to that obtained from clipping diode circuit, but the amplitude is higher.

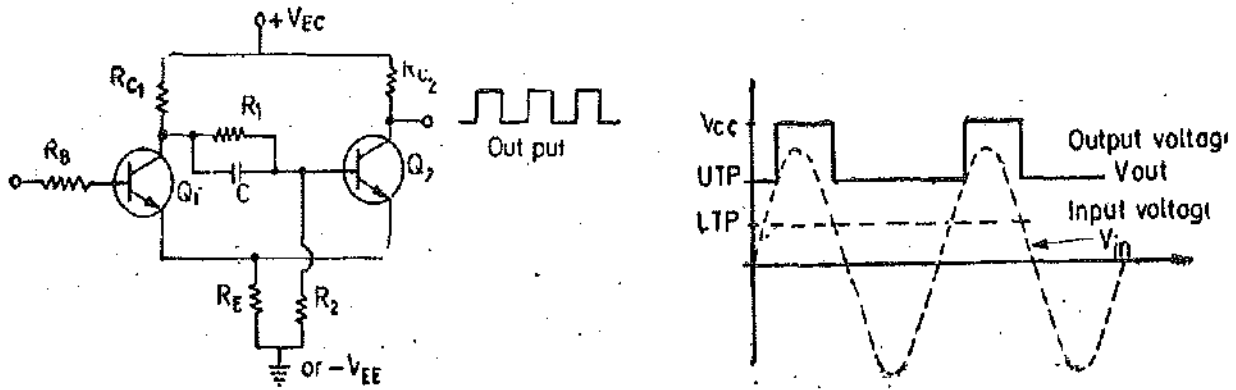

(a) Schmitt trigger circuit used to convert a sine wave into a rectangular wave.

(b) The upper and lower trip points on the input signal determine the width of output pulses.

Fig. 22-18

22-21. Schmitt Trigger Circuit

Fig. 22 18 (a) shows a typical Schmitt trigger circuit. There are two possible outputs from this circuit—the 1 level, which occurs when transistor Q_2 is turned off with transistor Q_1 turned on and the 0 level, which occurs when Q_2 is turned on with Q_1 turned off. The 1 level is approximately V_{CC} ; the 0 level is $V_o = V_E + V_{CE(sat)}$ where V_E is the voltage at the emitter.

R_{C1} is made larger than R_{C2} by about two to one or higher. This ensures that the voltage V_E is about twice as high with Q_2 conducting than it is with Q_1 conducting.

If Q_2 is turned on there is a voltage V_E developed across R_E , helping to insure that Q_1 remains turned off. In order to turn Q_1 and to have Q_2 turned off, the input on the base of Q_1 must rise to the level of $V_{BE(Q1)} + V_E$. This level is referred to as upper triggering level UTL —the input level that results in the output switching to the 1 level. As Q_1 turns on Q_2 turns off, reducing the voltage V_E (because $R_{C1} > 2R_{C2}$, i.e. $I_{E1} < \frac{1}{2}I_{E2}$) which helps to speed Q_1 to the ON state. Q_1 remains ON and the output continues at level 1 until the input signal falls to a voltage lower than the Q_1 turn on level. The turn off level for Q_1 is lower than the turn on level because of the reduced value of V_E . However, when Q_1 turns off its turn off is quickened because Q_2 subsequently turns ON, raising the level of V_E . The voltage V_E acts as a positive feedback, quickening the change of state, and reducing the rise and fall time of rectangular waveform.

Fig. 22 18 (b) shows the rectangular waveshape occurring at the Schmitt trigger output resulting from a sine wave applied at the input.

22-22. Active Square Wave Generators. Active square wave generators are usually of the relaxation type. The relaxation oscillator uses the charge and discharge action of a capacitor to control the conduction of vacuum tubes or transistors employed in the circuit. The most common forms of relaxation oscillators are the multivibrators and the blocking oscillators.

An astable multivibrator (free running multivibrator) is extensively used for production of square wave or pulses.

A commonly used circuit for an astable multivibrator is shown in Fig. 22-19 (a). The circuit consists of a two stage RC coupled amplifier. There are two transistor amplifiers Q_1 and Q_2 . The output of the second stage (Q_2) is connected to the input of the first stage (Q_1) through a capacitor C_1 . Similarly, the output of first stage (Q_1) is connected via C_2 to the input of second stage (Q_2). As the coupling between the two transistors is taken from the collectors, this circuit is also known as a collector-coupled astable multivibrator.

When the power is first applied to the circuit, both transistors start conducting. Due to small differences in their operating characteristics, one of the transistors conducts slightly more than the other. This starts a series of events. Let us assume that Q_1 initially conducts more than

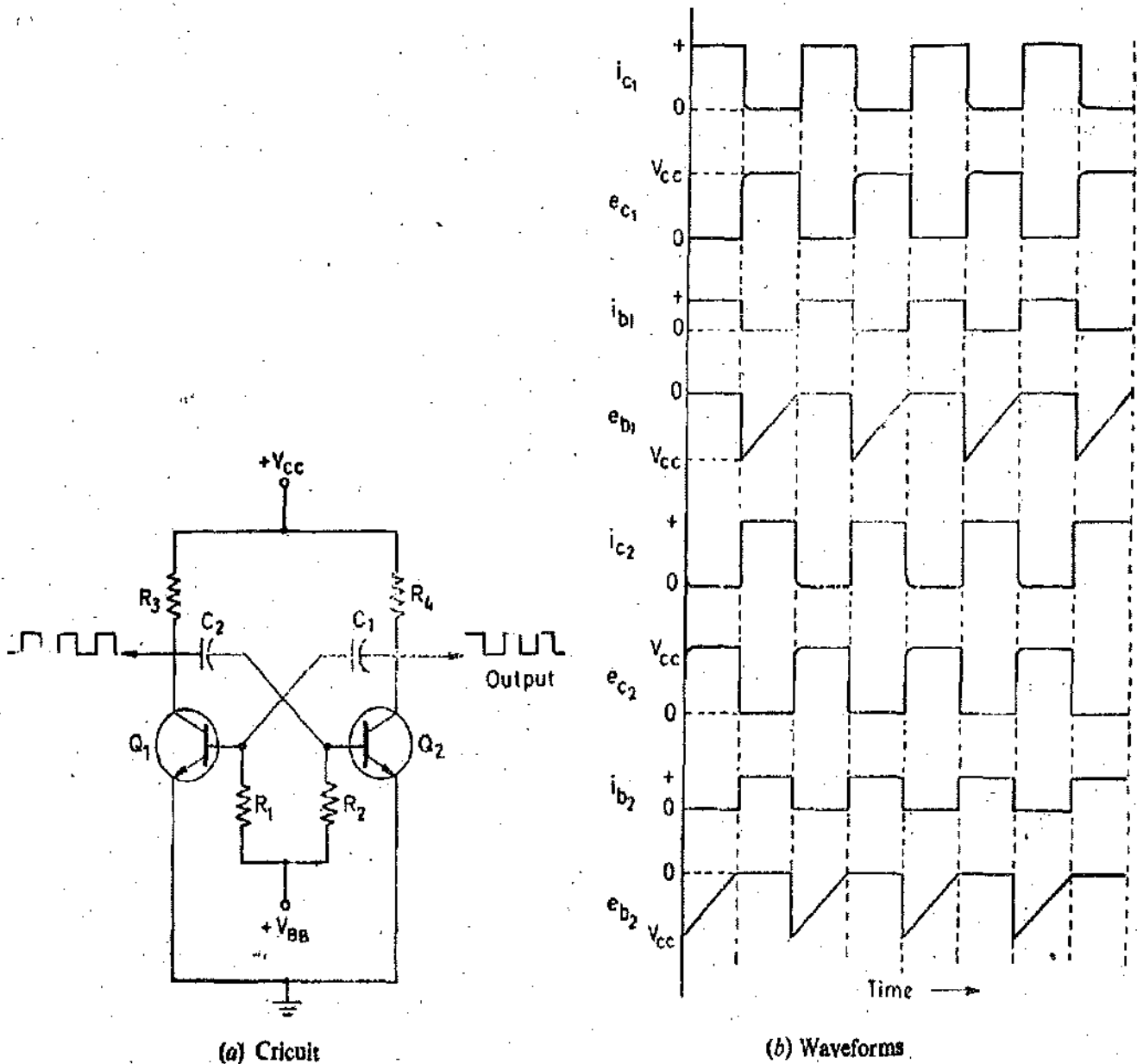

Fig. 22'19. The astable multivibrator.

Q_2 . This means that the collector voltage of Q_1 (e_{c1}) drops more rapidly than the collector voltage of Q_2 (e_{c2}). The decrease in e_{c1} is applied to the R_2C_2 network, and because the charge on C_2 cannot change instantaneously, the full negative-going change appears across R_2 . This decreases the forward bias on Q_2 which in turn decreases the collector current of Q_2 (i_{c2}). Therefore collector voltage of Q_2 rises. This rise in Q_2 collector voltage is applied through the R_1C_1 network to the base of Q_1 thereby increasing its forward bias. Hence Q_1 conducts even more heavily and its collector voltage drops still more rapidly. This negative-going change is coupled to the base of Q_2 , further decreasing its collector current. The entire process is cumulative until Q_2 is entirely cut off and Q_1 conducts heavily.

With Q_2 cut off, its collector voltage practically equals the supply voltage, V_{CC} , and capacitor C_1 charges rapidly to V_{CC} through the low-resistance path from emitter to base of the conducting transistor Q_1 . When the circuit action turns Q_1 fully on, its collector potential drops to approximately 0 V and since the charge on C_2 cannot change instantaneously, the base of Q_2 is at $-V_{CC}$ potential, with Q_2 driven deep into cut off.

The switching action starts now. Capacitor C_2 starts to discharge exponentially through R_2 . When the charge on C_2 reaches 0 V, C_2 tries to charge up to the value of $+V_{BB}$, the base supply voltage. But this action produces a forward bias on Q_2 and this transistor starts to conduct. As

soon as Q_2 starts conducting, its collector current causes a decrease in the collector voltage e_{c2} . This negative-going change is coupled to the base of Q_1 which begins to conduct less and therefore comes out of saturation. This cumulative action repeats until Q_1 finally is cut off and Q_2 starts conducting heavily. At this instant, the collector voltage of Q_1 reaches its maximum value of V_{cc} . Capacitor C_2 is charged to the full value of V_{cc} , and therefore a full cycle of operation is completed.

The waveforms appearing at the base and the collector of each transistor are the result of a symmetrical or balanced operation: the time constants, R_1C_1 and R_2C_2 , the transistors themselves, and the supply voltages are all identical. The conducting and non-conducting periods are therefore of almost the same duration. The waveforms for each of the two transistors are given in the waveform diagram of Fig. 22'19 (b).

In the case of symmetrical operation, when the time constants R_1C_1 and R_2C_2 are equal, the output waveform is a symmetrical square wave. If the time constant R_1C_1 is made larger than time constant R_2C_2 , the output waveform becomes a Pulse Train as the OFF time of Q_1 will, in that case, be greater than OFF time of Q_2 .

FUNCTION GENERATORS

22'23. Introduction. Function generators, as the name implies, generate specific types of waveforms or periodic functions such as sine, square, triangular and sawtooth waves.

The phase locked function generators may be used to produce any waveform. This can be done by phase locking one function generator to another and two output signals can be displaced in phase. In addition, one generator may be phase locked to any harmonic of the second generator. By adjusting the phase and amplitude of the harmonics, almost any waveform may be generated. In practice, however, a different approach is used to generate a particular waveform. A function generator circuit is described below.

22'24. Function Generator.

Fig. 22'20 shows the circuit of a typical function generator. This instrument delivers sine, triangular and square wave shapes. The typical frequency range may be 0'01 Hz to 100 kHz. The signal generator is provided with frequency control network. The frequency control voltage regulates two current sources.

For the generation of a triangular waveshape, an integrator circuit is used as shown. The upper current source supplies a constant current and therefore the output voltage of the integrator is :

$$E_0 = - \frac{1}{C} \int i dt = \frac{I}{C} t \text{ since } i \text{ is constant.}$$

It is clear from above that, the output voltage increases linearly with time.

The voltage comparator multivibrator is used to change state at a predetermined level on the positive slope of the integrator's output voltage. This cuts off the upper current supply and switches on the lower current supply. Since the direction of current supply from the lower source is in opposite direction to that of the upper current source, the output voltage decreases linearly with time till a change in state at a predetermined level is brought about by the voltage comparator multivibrator and the upper current source is switched on again. Hence we get a triangular waveshape. Since the slope of curve is determined by the magnitude of the current and

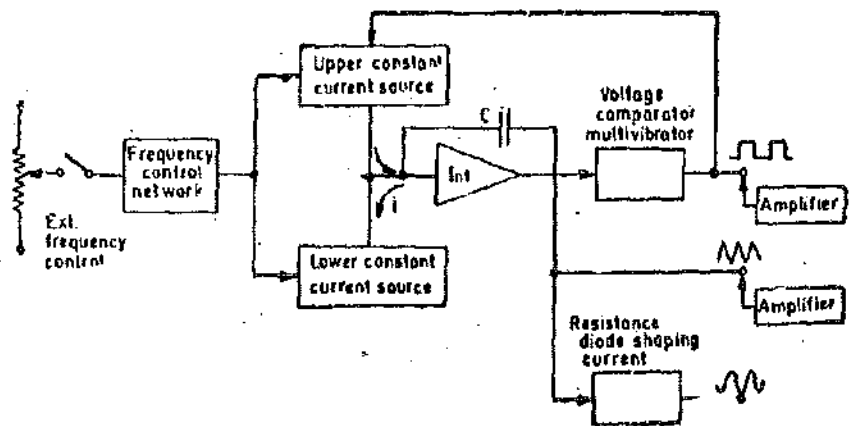

Fig. 22'20. Signal generator.

therefore the frequency of the output voltage is also determined by the magnitude of the current. This triangular waveform is obtained at the output of the integrator.

A square waveform is obtained at the output of the multivibrator. The third waveform is obtained when the triangular waveform is synthesised with a sinusoidal waveform. Output amplifiers are used to amplify the signals.

WAVE ANALYZERS

22.25. Introduction. It is well known that any periodic waveform can be represented as the sum of a d.c. component and a series of sinusoidal harmonics. Analysis of a waveform consists of determination of the values of amplitude, frequency, and sometime phase angle of the harmonic components. Graphical and mathematical methods may be used for the purpose but these methods are quite laborious. The analysis of a complex waveform can be done by electrical means using a band pass filter network to single out the various harmonic components. Networks of these types pass a narrow band of frequency and provide a high degree of attenuation to all other frequencies.

A wave analyzer, in fact, is an instrument designed to measure relative amplitudes of single frequency components in a complex waveform. Basically, the instrument acts as a frequency selective voltmeter which is tuned to the frequency of one signal while rejecting all other signal components. The desired frequency is selected by a frequency calibrated dial to the point of maximum amplitude. The amplitude is indicated either by a suitable voltmeter or a CRO.

22.26. Resonant Wave Analyzers. Fig. 22.21 shows a simple circuit of a resonant wave analyzer. This circuit uses an LC resonant network which can be tuned to a particular harmonic component to be measured. The signal is rectified and measured by a PMMC instrument calibrated to read the peak value of the sinusoidal voltage. The LC resonant circuit passes only one frequency while it highly attenuates the signals of other frequencies. Several of such circuits may be used, each tuned to a different frequency with their outputs connected through a selector switch to the rectifier and the indicating device (voltmeter or CRO).

This simple circuit suffers from some disadvantages :

- (i) The ability of this circuit to distinguish between components of two frequencies, i.e., its resolution, is poor.
- (ii) If fixed tuned L-C circuit is used, the frequency of the components must be known.
- (iii) At low frequencies, very large values of L and C are required and their physical size becomes rather impracticable.

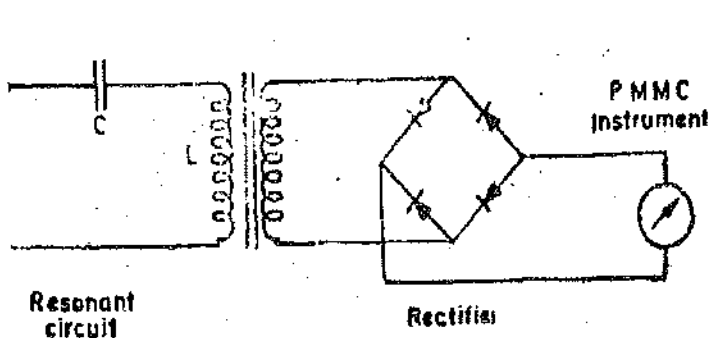

Fig. 22.21 Resonant wave analyzer.

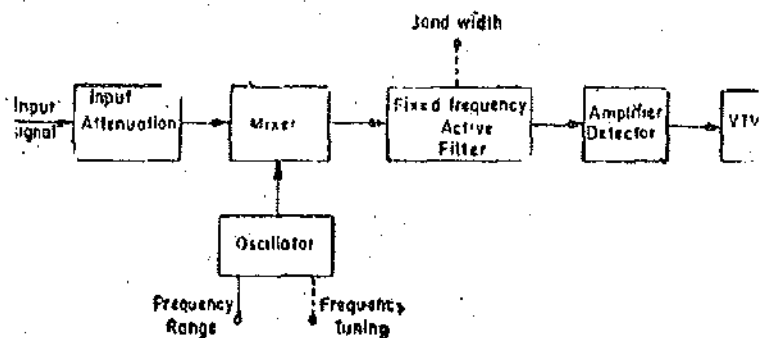

Fig. 22.22. Hetrodyne wave analyzer.

However, this system is useful in some applications, particularly where the fundamental frequency is known and where qualitative rather than quantitative analysis is required.

22.27. Hetrodyne Wave Analyzer or Wavemeter. The hetrodyne wave analyzer has certain advantages and overcomes some of the difficulties encountered in a resonant wave analyzer. A

heterodyne wave analyzer uses a highly selective fixed frequency filters. Fig. 22'22 shows the basic functional diagram of the heterodyne wave analyzer.

The output of a variable frequency oscillator is heterodyned (mixed) successively with each harmonic of the input signal. Thus in this system, the signal from the oscillator heterodynes with the input signal to produce output signals having frequencies equal to the sum and difference of the oscillator frequency f_0 and frequency f of the input signal, that is, f_0+f and f_0-f . Thus a continuous coverage over a wide range of frequency is obtained instead of discrete steps in the case of resonant frequency oscillators.

Since each harmonic frequency can be and is converted into a constant frequency, it is possible to use highly selective filters of the quartz crystal type. Thus this circuit ensures that a constant frequency signal corresponding to a particular harmonic being measured, is passed through the filter and is metered by the metering circuit. The output meter employed is usually a balanced bridge VTVM or a TVM. In heterodyne wave analyzers the meter reading is directly calibrated in terms of voltage and therefore they are sometimes known as frequency selective voltmeters. Heterodyne wavemeters may be used as distortion meters when they compare the amplitude of harmonics of the impressed voltage with a reference source making the reference voltage equal to the amplitude of the fundamental.

The frequency of the harmonic is read off directly on a calibrated dial. Normally the network employs a low pass filter in the input circuit which excludes the sum of the frequency and passes only the difference of frequencies i.e. f_0-f .

HARMONIC DISTORTION ANALYZERS

22'28. Introduction. Another measurement which provides information on the waveform of an alternating voltage or current is the harmonic distortion. This type of measurement is used for testing of amplifiers and networks as to what extent they distort the input signal.

A measure of the distortion represented by a particular harmonic is simply the ratio of amplitude of harmonic to that of fundamental. Harmonic distortion (HD) is then represented by :

$$D_2 = \frac{E_2}{E_1}, D_3 = \frac{E_3}{E_1}, D_4 = \frac{E_4}{E_1}$$

where D_n ($n=2, 3, 4, \dots$) represents the distortion of n th harmonic and E_n represents the amplitude of n th harmonic. E_1 is the amplitude of the fundamental.

The total harmonic distortion or distortion factor is defined as

$$D = \sqrt{D_2^2 + D_3^2 + D_4^2 + \dots} = \frac{\sqrt{E_2^2 + E_3^2 + E_4^2 + \dots}}{E_1}$$

Percentage harmonic distortion

$$= \sqrt{D_2^2 + D_3^2 + D_4^2 + \dots} \times 100 = \frac{\sqrt{E_2^2 + E_3^2 + E_4^2 + \dots}}{E_1} \times 100$$

The harmonic distortion can be computed from the measurements of wave analyzer circuits described earlier. However instruments are available whereby the distortion can be measured directly.

22'29. Distortion Meters. These instruments operate on the principle of first measuring the rms value of the total wave (fundamental plus harmonics) and then removing the fundamental component by means of a highly selective filter circuit and measuring the rms value of harmonics only. A block diagram of a distortion meter of this type is shown in Fig. 22 23. First the rms value of the total wave is measured with selector switch in position 1 and the circuit is so adjusted that the meter reads 100%. The selector switch is then put to position 2. This cuts in the filter

which rejects the fundamental frequency component, and meter reads the rms value of the harmonics only. Thus the meter indicates the percentage distortion directly.

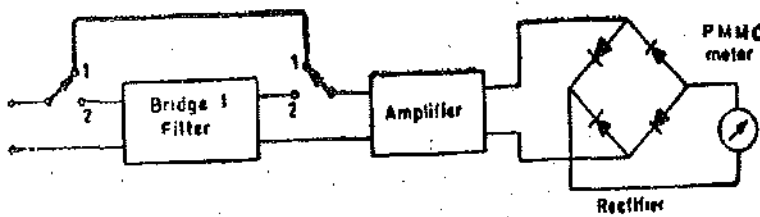

Fig. 22'23. Harmonic distortion meters.

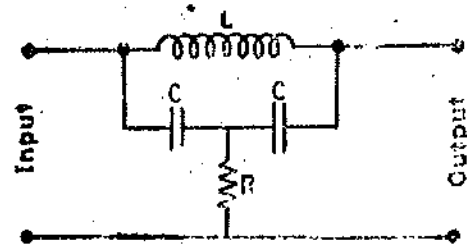

Fig. 22'24. Bridge 'T' Filter circuit.

A 'T' bridge circuit is commonly employed to reject the fundamental frequency. This circuit is shown in Fig. 22'24.

It can be shown that if the circuit is tuned to the fundamental frequency of $f_0 = 1/2\pi \sqrt{2/LC}$ and R is adjusted to satisfy the relation $R = Q_L X_L/4$.

where $Q_L = X_L/R_L$ with R_L = resistance of inductor, the attenuation of fundamental frequency components is infinite under these conditions.

SPECTRUM ANALYZERS

22'30. Introduction. Spectrum analysis is defined as the study of energy distribution across the frequency spectrum of a given electrical signal. The study gives valuable information about bandwidth, effects of different types of modulation and spurious signal generation. The knowledge of the above quantities and phenomena are useful in the design and testing of radio frequency (RF) and pulse circuitry.

The spectrum analysis is divided into two major categories on account of instrumentation limitations and capabilities. They are: (i) Audio frequency (AF) analysis, and (ii) Radio frequency (RF) spectrum analysis. The RF spectrum analysis covers a frequency range of 10 MHz to 40 GHz, and hence is more important, because it includes the vast majority of communication, navigation, radar, and industrial instrumentation frequency bands.

The spectrum analyzers are sophisticated instruments which are capable of portraying graphically the amplitude as a function of frequency in a portion of RF spectrum. These instruments find wide applications for measurement of attenuation, FM deviation, and frequency in pulse studies.

22'30'1. Basic Spectrum Analyzer. The basic spectrum analyzer is designed to represent graphically, a plot of amplitude versus frequency of a selected portion of the frequency spectrum under study. The modern spectrum analyzer basically consists of a narrow band superheterodyne receiver and a CRO. The receiver is electronically tuned by varying the frequency of the local oscillator. A simplified block diagram of a swept-frequency spectrum analyzer is shown in Fig. 22'25.

The circuit incorporates a sawtooth generator which supplies a ramp voltage to the frequency control element of the voltage tuned local oscillator. The local oscillator then sweeps through its frequency band at a recurring linear rate. The same sawtooth voltage is simultaneously applied to the horizontal plates of the CRO. The RF signal to be tested is applied to the input of the mixer stage.

The sawtooth generator makes the local oscillator sweep through its frequency band to beat with the input signal to produce the desired intermediate frequency (IF). An IF component is produced only when the corresponding component is present in the RF input signal. The resulting IF signals are amplified, and then detected. After that they are applied to the vertical deflection plates of the CRO, thereby producing a display of amplitude versus frequency on the screen.

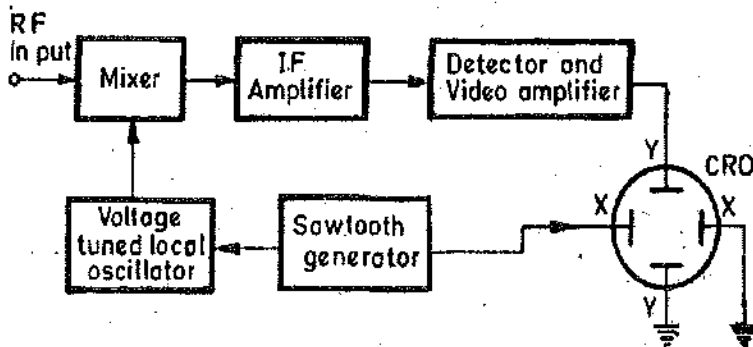

Fig. 22'25. Basic swept receiver spectrum analyzer.

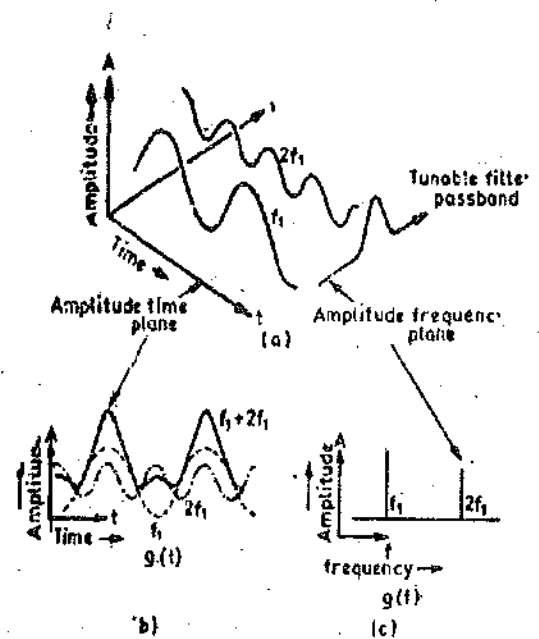

Fig. 22'26. A three-dimensional presentation of amplitude, frequency, and time. (a) The addition of a fundamental and its second harmonic. (b) View seen in the Time-Amplitude plane. On an oscilloscope, only the composite f_1+2f_1 would be seen. (c) View seen in the Frequency-Amplitude plane. The components of the composite signal are clearly seen.

22'30'2. Spectral Displays. Normally a CRO is used for display of electrical signals with respect to time, with the X-axis of CRO calibrated to read directly the rise time, pulse width, and the repetition rate. Such measurements are said to be in **Time Domain**. However, in the case of spectrum analyzers, the signals are broken down into their individual frequency components and displayed along X-axis of the CRO which is calibrated in terms of frequency. Therefore, the signal amplitude is displayed versus frequency. These measurements are then said to be in the **Frequency Domain**.

A three dimensional representation of a fundamental frequency, f_1 , and its second harmonic, $f_2=2f_1$, is shown in Fig. 22'26. The two signals and the sum instantaneous values, as displayed on a CRO screen are shown in Fig. 22'26 (b). The two signals are shown in Fig. 22'26 (c) on amplitude-frequency plane and are portrayed on the CRO as two components of the composite signal, as the window of the spectrum analyzer sweeps across the frequency range of the signal.

22'30'3. Spectra of Different Signals. Let us consider some of the commonly used signals in order to illustrate the spectra which are displayed on the CRO when they are applied to the spectrum Analyzer.

1. Continuous Wave (CW) Signals. When a continuous wave (CW) input signal is slowly swept through by the spectrum analyzer's local oscillator, the response displayed on the screen is a plot of the IF amplifier pass band. Since the CW signal has energy at only one frequency and therefore, the display on the screen is a single spike. This occurs in case the total RF sweep width or **Spectrum Width** is wide as compared to the IF band width in the analyzer.

2. Amplitude Modulation. When a continuous wave signal of frequency, f_c , is amplitude modulated by an input signal of frequency, f_m , two side-band frequencies of f_c+f_m and f_c-f_m are produced. The display on the spectrum analyzer screen is a signal of frequency f_c , with two side-band frequencies whose magnitude relative to the carrier frequency depends upon the percentage of modulation. This is illustrated in Fig. 22'27.

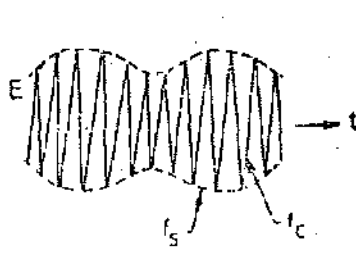

(a) Fig. 22.27. A single-tone amplitude modulation. (a) Time-amplitude plot. (b) Frequency-amplitude plot.

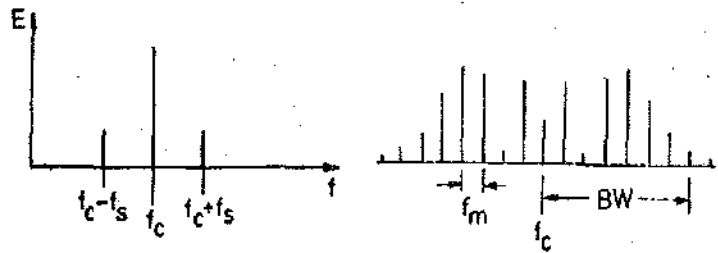

Fig. 22.28. Amplitude spectrum of single-tone frequency modulation.

If the frequency, the spectrum width, and the vertical response of the analyzer are calibrated, the display on the CRO screen provides the following information in numerical terms, (a) carrier frequency, (b) modulation frequency, (c) modulation percentage, (d) non-linear modulation, (e) incidental frequency modulation, (f) spurious signal location and strength.

3. **Frequency Modulation.** If a CW signal f_c is frequency modulated at a rate f_r , it will produce an infinite number of sidebands. These are located at intervals of $f_c + nf_r$, where n = an integer, 1, 2, 3, ... In practice, only the sidebands containing significant power are usually considered. A frequency modulated display is shown in Fig. 22 28.

4. **Pulse Modulation.** An idealized rectangular waveform, with zero rise time and no overshoot is shown in Fig. 22.29 (a). This pulse is shown in the time domain, but when its frequency spectrum is to be analyzed, it must be broken down into its individual frequency components. This is shown in Fig. 22.29 (b), where a constant voltage, a fundamental frequency, and its third harmonic are added algebraically to form a wave which eventually becomes a square wave as more odd harmonics are added in phase with the fundamental. The pulse becomes perfectly rectangular if an infinitely large number of odd harmonics are added. A spectral plot, in the frequency domain, would

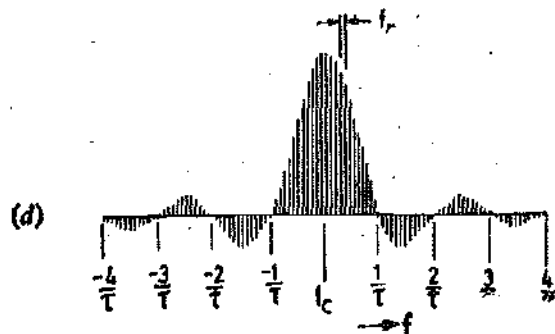
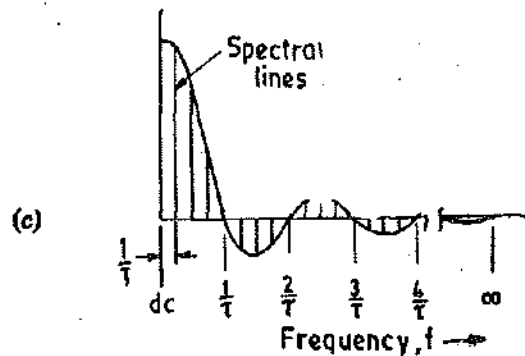
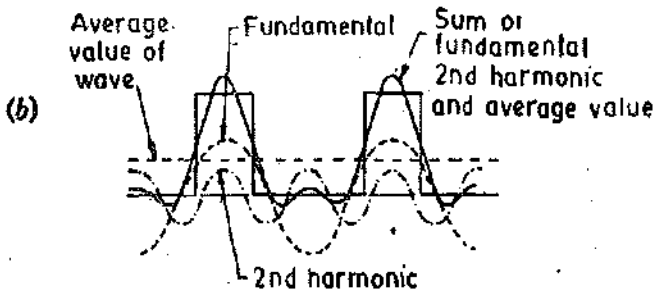
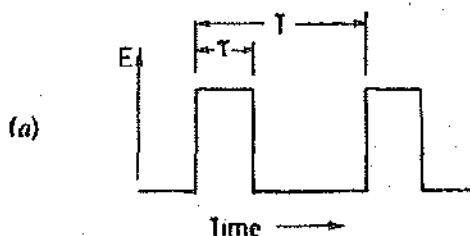

Fig. 22.29. Pulse modulation. (a) Periodic rectangular pulse train. (b) Addition of a fundamental cosine wave and its harmonics to form rectangular pulses. (c) Spectrum of a perfectly rectangular pulse. Amplitudes and phases of an infinite number of harmonics are plotted resulting in smooth envelope as shown. (d) Resultant spectrum of a carrier amplitude, modulated with a rectangular pulse.

have the form given in Fig. 22 29 (c), where the amplitude and phases of an infinite number of harmonics are plotted, resulting in a smooth envelope as shown.

When this pulse is used for amplitude modulating a carrier, the sums and differences of the carrier and all harmonic components contained in the pulse are produced. The harmonic frequencies therefore produce multiple sidebands, in exactly the same manner that the modulating signal in amplitude modulation does. These multiple sidebands are generally referred to as spectral lines on the analyzer display. There will be twice as many sidebands or spectral lines as there are harmonic frequencies contained in the modulating pulse. Fig. 22 29(d) shows the spectral plot which results from rectangular pulse modulation of a carrier. The individual lines represent the modulation product of the carrier and the modulating pulse frequency with its harmonics. Therefore, the lines will be spaced in frequency by an amount equal to the pulse repetition rate of the original pulse waveform. The main lobe in the centre and the side lobes are shown as groups of spectral lines extending above and below the base line. For a perfectly rectangular pulse, the number of side lobes is infinite. The main lobe contains the carrier frequency, represented by the longest line in the centre.

There are a number of other useful applications of this instrument. A few typical examples are cited :

- (1) Pulse-width and repetition rate measurements.
- (2) Tuning a parametric amplifier.
- (3) FM deviation measurement.
- (4) RF interference testing.
- (5) Antenna pattern measurements.

High Frequency Measurements

23'1. Introduction. In this chapter methods for measurement of inductance, capacitance and resistance in the frequency range of 0.1 to 100 MHz are described. No doubt, some of the methods described earlier *i.e.*, bridge methods can be used in this frequency range but these methods give erroneous results on account of the fact that these methods do not take into consideration the effects which are inherent in any measurement at high frequencies. Some of these special effects which are predominant at high frequencies are :

- (i) high reactance due to stray series inductance and its variation with frequency ;
- (ii) low reactance due to stray shunt capacitance and its variation with frequency ;
- (iii) increase of effective resistance with frequency on account of skin effects ;
- (iv) increase of effective resistance on account of proximity effects ;
- (v) variation of dielectric loss of capacitors with frequency.

These effects make the high frequency measurements complex. If bridge circuits are used at high frequencies, elaborate shielding arrangements have to be adopted to nullify the effects of factors listed above.

The normal approach for measurements at high frequencies is to adopt such methods which are as simple as possible so that the effects of stray electric and magnetic fields are easy to remove. Since errors of the order of 1 to 5 percent are acceptable in measurements in this frequency range, the methods used involve use of very simple apparatus which may include :

- (i) a set of inductors from 1.0 μH to 10 mH,
- (ii) a variable air capacitor of maximum capacitance 1000 pF,
- (iii) a decade resistance box of resistance upto 100 Ω ,
- (iv) a thermo electric ammeter or a VTVM or a TVM in order to indicate resistance conditions.

23'2. Resonance Methods. Most of the methods used for high frequency measurements employ a series RLC resonant circuit as shown in Fig. 23'1. The emf for the circuit is obtained by coupling the coil L with the output coil of an oscillator. A loose coupling is desirable in order that the changes in conditions of the RLC circuit do not effect the oscillator circuit. A tight coupling on the other hand, will affect the oscillator.

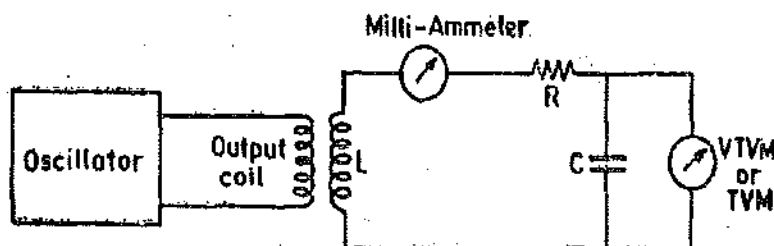

Fig. 23'1. RLC resonant circuit.

Resonance is obtained either by variation of frequency of the oscillator or by variation of the capacitance. The resonance conditions are indicated by the thermal milli-ammeter connected in the circuit. (A thermal milli-ammeter is necessary as it can be worked at high frequencies). Under resonance conditions the milli-ammeter indicates maximum reading. However, in practice it is convenient to use a VTVM or a TVM connected across the capacitor C to indicate the resonance

conditions since the ammeter introduces an extra series resistance in the circuit which may be undesirable under many circumstances. The resonance is indicated when the voltmeter reads maximum. However, it is interesting to note that the circuit conditions which give maximum current are not the same as those which show maximum voltage across capacitor C , but, for high Q circuits the difference between the two conditions is negligible. Hence, in general, it is assumed that when the voltmeter connected across C shows maximum reading, the circuit is having maximum current *i.e.* the circuit is working under resonance conditions.

Another assumption, which is made for resonance methods, is that the resonance curve is symmetrical about its maximum ordinate. This condition is valid only when :

(i) the curve is highly peaked *i.e.* highly selective which is the case when the circuit has a high Q ;

(ii) the readings are taken in the vicinity of the resonance point. To satisfy the condition, (ii) measurements should be limited to values of current greater than 50% of the maximum value of current.

23.3. Measurement of Inductance. Fig. 23.2 (a) shows a simple circuit for measurement of inductance, L , of a coil. In this the coil under measurement is loosely coupled to the output coil of a variable frequency oscillator. The dial of the oscillator is calibrated in terms of frequency. A variable capacitor, C , is used for obtaining resonance conditions which are indicated by a VTVM or a TVM connected across it.

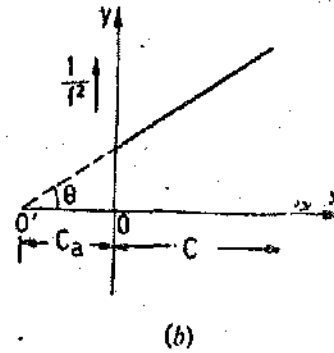
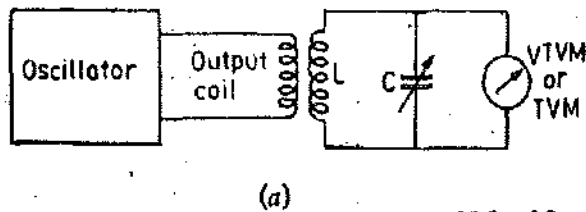

Fig. 23.2. Measurement of inductance.

$$\text{At resonance } LC = \frac{1}{\omega^2} = \frac{1}{4\pi^2 f^2} \quad \dots(23.1)$$

Thus knowing the value of frequency, f , and capacitance, C , the value of inductance can be calculated.

The above method apparently looks very simple but the value of inductance obtained this way is rarely accurate. The reasons are discussed below :

The above method does not take into account the additional capacitances which are introduced into the circuit. Also errors are caused due to the fact that the dial setting of capacitor, C , may not be accurately known. To offset the influence of above effects and to get improved accuracy a number of readings are taken by varying the frequency, f .

Let C_a be the value of additional capacitance. Therefore, for resonance at any frequency

$$L(C + C_a) = 1/4\pi^2 f^2 \quad \dots(23.2)$$

$$\text{or } 1/f^2 = 4\pi^2 L(C + C_a) = 4\pi^2 LC + 4\pi^2 LC_a \quad \dots(23.3)$$

From Eqn. 23.3, it is clear that if a curve is plotted between $1/f^2$ and C , we get a straight line as shown in Fig. 23.2 (b). The line produced back cuts the x -axis at O' . The slope of the line is $\tan \theta = 4\pi^2 L$.

$$\therefore L = \tan \theta / 4\pi^2 \quad \dots(23.4)$$

Thus knowing the value of slope of the line, the value of inductance, L , may be obtained.

The value of additional capacitance, C_a , is equal to the intercept OO' . Now,

$$C_a = C_d + C_v \quad \dots(23'5)$$

where

C_d = self-capacitance of the coil, C_v = capacitance of voltmeter.

Eqn. 23'5 is true only when the calibration of capacitance C includes the effects of its screen capacitances. Under this condition, the method affords a means of measurement of self-capacitance of coils.

In the above analysis we have assumed that the value of inductance, L , remains constant. However, this is not strictly true as the effective value of inductance changes with frequency. Thus this method gives erroneous results for coils whose effective self inductance varies considerably over the range of frequency used. It is clear from Eqn. 23'3 that we get a straight line relationship between C and $1/f^2$ only if L remains constant over the range of frequency used. Thus if the value of self-inductance, L , changes with frequency we do not get a straight line but a curve. Therefore, in order to determine the value of L at a particular frequency, a tangent is drawn to the curve at a value the frequency where the value of inductance is required. The value of inductance is determined from the slope of this curve using Eqn. 23'4.

Example 23'1. A capacitance of 250 pF produces resonance with a coil at a frequency of $(2/\pi) \times 10^6$ Hz, while at the second harmonic of this frequency resonance is produced by a capacitance of 50 pF. Calculate: (a) the self-capacitance, and (b) the inductance of the coil. Neglect the effect of voltmeter capacitance and also other stray capacitances.

Solution. Suppose C = capacitance of variable capacitor,
 C_a = self-capacitance of coil, and L = inductance of coil.

At resonance, $L = 1/4\pi^2 f^2 (C + C_a)$

$$\therefore L = \frac{1}{4\pi^2 \times (2/\pi)^2 \times 10^{12} (250 + C_a) \times 10^{-12}} = \frac{1}{16(250 + C_a)} \quad \dots(i)$$

$$\text{and also } L = \frac{1}{4\pi^2 \times (4/\pi)^2 \times 10^{12} (50 + C_a) \times 10^{-12}} = \frac{1}{64(50 + C_a)} \quad \dots(ii)$$

From (i) and (ii), $16(250 + C_a) = 64(50 + C_a)$ or self-capacitance $C_a = 16.6$ pF.

From (i) inductance, $L = \frac{1}{16(250 + 16.6)} \text{ H} = 234 \text{ } \mu\text{H}$.

Example 23'2. A coil of unknown inductance and self-capacitance is connected in series with a standard variable capacitor C . A VTVM is connected across C . A variable frequency oscillator is loosely coupled to the coil and the circuit is adjusted to resonance for each different oscillator frequency f by adjusting C , as in the following table:

f , kHz	350	400	450	500	600
C , pF	132	98	73	55	31

Determine: (a) the inductance, and (b) the self-capacitance of the coil. The input capacitance of VTVM is 4.5 pF and the lead capacitance is 1.5 pF.

Solution. The method has been explained in Art. 23'3. A curve is drawn between $1/f^2$ and C . The points for the graph are:

C, pF	132	98	73	55	31
f, kHz	350	400	450	500	600
1/f ²	8.16 × 10 ⁻¹²	6.25 × 10 ⁻¹²	4.93 × 10 ⁻¹²	4.0 × 10 ⁻¹²	2.78 × 10 ⁻¹²

The graph is plotted in Fig. 23.3.

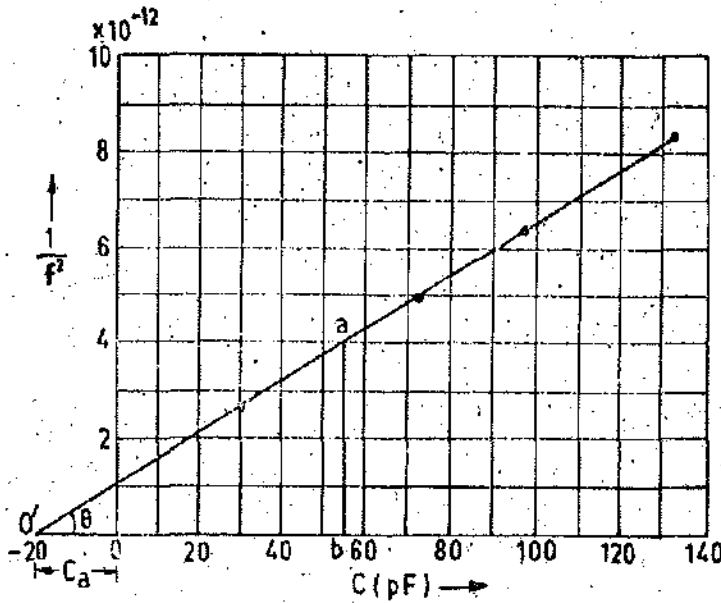

Fig. 23.3

From the graph, additional capacitance, $C_a = 20$ pF.

Capacitance of voltmeter and leads = $4.5 + 1.5 = 6$ pF.

∴ Self-capacitance of coil $C_a = 20 - 6 = 14$ pF.

Slope of line $\tan \theta = \frac{ab}{O'b} = \frac{4 \times 10^{-12}}{75 \times 10^{-12}} = \frac{4}{75}$

From Eqn. 23.4, inductance of coil $L = \frac{\tan \theta}{4\pi^2} = \frac{4}{75} \times \frac{1}{4\pi^2} \text{ H} = 1.35 \text{ mH}$.

23.4. Measurement of Capacitance. capacitance at high frequencies. Fig. 23.4. shows a simple circuit for measurement of capacitance. C is the unknown capacitance connected in parallel with a variable standard capacitance C_s . The standard capacitance is of the same order as the unknown capacitance.

Substitution method is normally used for measurement of

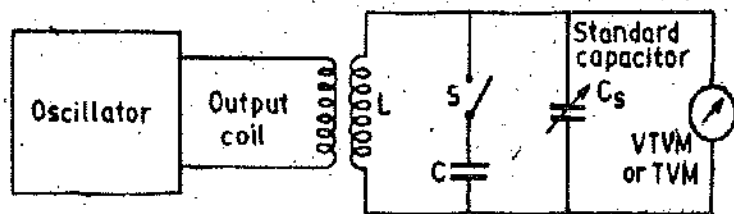

Fig. 23.4. Measurement of capacitance by substitution method.

With switch S open, resonance is obtained by varying the standard capacitance C_s . The resonance condition is indicated by a VTVM or a TVM connected across C_s .

Let

- f = frequency at resonance ; Hz,
- L = inductance of coil coupled the output of oscillator ; H,
- C_s = setting of standard capacitor with switch S open ; F.

$$\therefore \text{ We have } C_{s1} = \frac{1}{4\pi^2 f^2 L} \quad \dots(23'6)$$

Now the switch S is closed putting unknown capacitance in parallel with C_s . Keeping the frequency f the same as earlier, resonance conditions are obtained by varying C_s .

Let C_{s2} = setting of standard capacitor with switch closed.

$$\therefore \text{ We get } C + C_{s2} = 1/4\pi^2 f^2 L \quad \dots(23'7)$$

From Eqns. 23'6 and 23'7, value of unknown capacitance is : $C = C_{s1} - C_{s2}$.

Thus the value of unknown capacitance is directly known from the difference of the two settings of the standard capacitor.

23'5. Measurement of Effective Resistance. There are two methods of measurement of effective resistance of a series RLC resonant circuit.

(i) Resistance variation method, and (ii) Reactance variation method.

23'6. Resistance Variation Method. The effective series resistance of a resonant circuit is measured by adding extra resistance from outside.

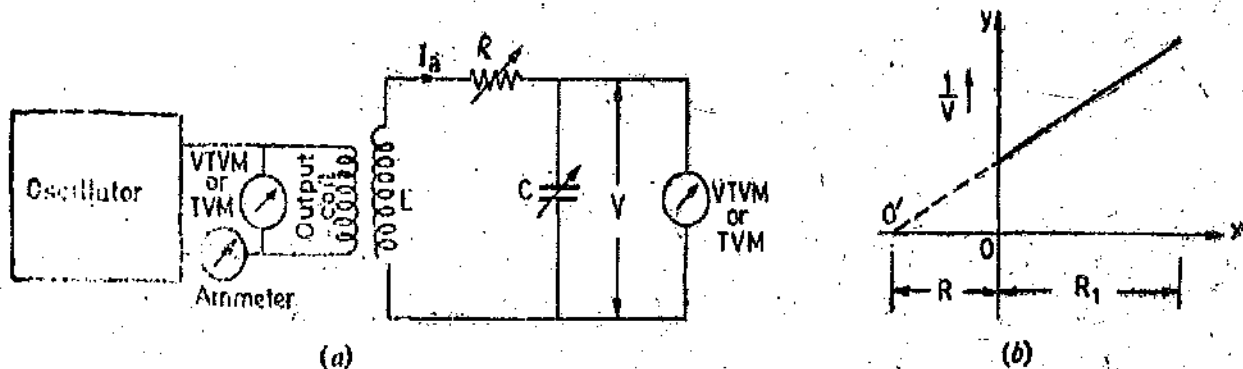

Fig. 23'5. Measurement of effective resistance by resistance variation method.

Let E = induced emf in the resonant circuit, I_0 = current in the resonant circuit,
 R = effective resistance of resonant circuit excluding resistance R_1 ,
 R_1 = additional resistance inserted in the resonant circuit,
 L = inductance of coil, C = capacitance,
 V = reading of voltmeter connected across C , and f_0 = resonant frequency.

$$\text{At resonance } I_0 = \frac{E}{R + R_1} \quad \dots(23'9)$$

$$\therefore \text{ Voltage } V = \frac{I_0}{2\pi f_0 C} = \frac{E}{(R + R_1)2\pi f_0 C} \quad \dots(23'10)$$

$$\text{or } R + R_1 = \frac{E}{2\pi f_0 C V} \quad \dots(23'11)$$

If the values of E , f_0 and C are kept constant, we get

$$R + R_1 = \frac{K}{V} \quad \dots(23'12)$$

where $K = \text{a constant} = \frac{E}{2\pi f_0 C} \quad \dots(23'13)$

Thus, under the above conditions if a curve is plotted between $1/V$ and R_1 , we get a straight line as shown in Fig. 23'5 (b).

The effective resistance is given by the intercept OO' provided that the loss resistance of capacitor and the resistance of the leads is negligible. From the above analysis we conclude :

(i) We can determine the value of effective resistance of a resonant circuit by inserting an external variable resistance R_1 . The circuit is set into resonance by varying the value of C . This value of capacitance C is kept constant afterwards. We go on increasing the value of R_1 . This does not disturb the resonance conditions and its effect is only to decrease the value of resonance current I_0 and to decrease the value of voltage V across the capacitor C . Thus an increase in the value of R_1 decreases V and increases the value of $1/V$.

(ii) The analysis is valid only if the value of induced emf E in the resonant circuit is constant. Also the resonant frequency f_0 is constant. This requires that the coupling between the oscillator circuit and the resonant circuit be very loose otherwise changes in the resonant circuit would affect the oscillator circuit. In order to ensure that the value of induced emf and the resonant frequency remain constant for all the readings, the oscillator should possess a high degree of frequency and amplitude stability.

(iii) We have explained above that the value of induced emf E in the resonant circuit should remain constant. This can be checked by connecting a thermal ammeter in series with the output coil of the oscillator or by connecting a VTVM or a TVM across the output coil of the oscillator.

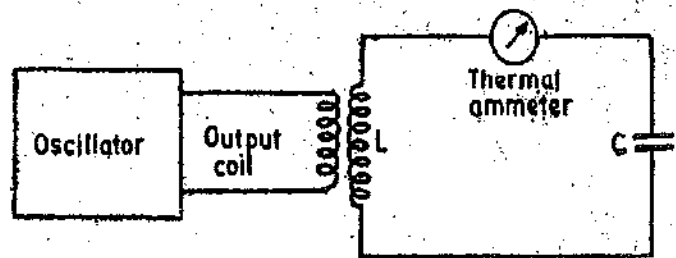

Fig. 23'6. Measurement of effective resistance by reactance variation method.

23'7. Reactance Variation Method. The effective resistance of a resonant circuit can be measured by variation of reactance of the circuit. Fig. 23'6 shows the circuit for such a measurement.

In this circuit a thermal ammeter is used to measure the value of current flowing. The circuit reactance is varied by either varying the value of capacitance C or the frequency f . The reactance is adjusted till the ammeter reads maximum value. This happens when the circuit is under resonance conditions.

The maximum value of current : $I_0 = \frac{E}{R}$... (23'14)

where E = emf induced, and R = effective value of resistance.

The reactance is then adjusted so that the current $I = I_0/\sqrt{2}$

$$I = \frac{E}{\sqrt{R^2 + X^2}} = \frac{I_0}{\sqrt{2}} = \frac{E}{\sqrt{2} R}$$

Hence,

$$\sqrt{R^2 + X^2} = \sqrt{2} R$$

or

$$X = \pm R \quad \dots (23'15)$$

There are, therefore, two values of reactance X which give a current, $I = I_0/\sqrt{2}$.

The difference of these two values of reactance gives twice the value of effective resistance i.e. $2R$.

As mentioned above there are two ways of varying the reactance :

(i) variation of capacitance, C , and (ii) variation of frequency f .

The two methods are discussed below :

1. Variation of Capacitance. In this method the value of frequency f is kept constant and the capacitance is varied. Let the value of capacitance which gives the maximum current I_0 be C_0 and the two values of capacitance which give a current of $I_0/\sqrt{2}$ be C_1 and C_2 .

Therefore,

$$2R = 1/\omega C_2 - 1/\omega C_1$$

or

$$R = \frac{C_1 - C_2}{2\omega C_1 C_2} = \frac{C_1 - C_2}{4\pi f C_1 C_2} \quad \dots(23'16)$$

Now if the circuit loss is small and the resonance is peaked and symmetrical

$$C_1 C_2 = C_0^2 \quad \dots(23'17)$$

\therefore

$$R \approx \frac{C_1 - C_2}{2\omega C_0^2} \approx \frac{C_1 - C_2}{4\pi f C_0^2} \quad \dots(23'18)$$

Also

$$Q = \omega L/R = 1/\omega C_0 R \quad \dots(23'19)$$

$$\approx \frac{2C_0}{C_1 - C_2} \quad \dots(23'20)$$

The accuracy of this method depends upon the accuracy with which the difference $C_1 - C_2$ can be known. For accurate determination of this difference a micrometer capacitor is put in parallel with the main capacitor. From Equ. 23'20 it is clear that the circuit Q can be determined in terms of two values of capacitance.

2. Variation of Frequency. In this method the capacitance C is kept constant and the frequency is varied. Let ω_0 be the angular frequency to give maximum current I_0 and ω_1 and ω_2 be the two frequencies which give a value of current $I = I_0/\sqrt{2}$.

$$\begin{aligned} \therefore 2R &= (\omega_1 L - 1/\omega_1 C) - (\omega_2 L - 1/\omega_2 C) = (\omega_1 - \omega_2)L + 1/C(1/\omega_2 - 1/\omega_1) \\ &= (\omega_1 - \omega_2)L + \omega_0^2 L \cdot (\omega_1 - \omega_2)/(\omega_1 \omega_2) \quad \text{as } \omega_0^2 L = 1/C. \end{aligned}$$

$$\text{Now for a peaked and symmetrical resonance curve } \omega_0^2 = \omega_1 \omega_2 \quad \dots(23'21)$$

$$\therefore 2R \approx (\omega_1 - \omega_2)L + \omega_0^2 L \cdot \frac{\omega_1 - \omega_2}{\omega_0} \approx 2(\omega_1 - \omega_2)L$$

$$\text{or } R \approx (\omega_1 - \omega_2)L \quad \dots(23'22)$$

$$\approx \frac{\omega_1 - \omega_2}{\omega_0^2 C} \quad \dots(23'23)$$

and

$$Q = \frac{\omega_0 L}{R} = \frac{\omega_0}{\omega_1 - \omega_2} \quad \dots(23'24)$$

The frequency variation method has a disadvantage because it is quite difficult to keep the value of induced emf E constant with change of frequency. But the error introduced on this account is small and can be allowed for.

Example 23'3. A coil of inductance L is tuned by a capacitance C to resonate at 1 MHz. A standard capacitor of 230 pF is tuned to resonate with the same coil at 2 MHz. If the resonance is indicated by VTVM of capacitance 8 pF in parallel with the circuit, calculate the values of L and C .

$$\text{Solution. We have } C + C_v = 1/4\pi^2 L (1 \times 10^6)^2$$

$$\text{or } (C + 8) \times 10^{-12} = 1/(4\pi^2 L \times 10^{12}) \quad \dots(i)$$

$$\text{and } (C + C_v) \times 10^{-12} = 1/4\pi^2 L (2 \times 10^6)^2 \quad \text{or } (230 + 8) \times 10^{-12} = 1/(16\pi^2 L \times 10^{12}) \quad \dots(ii)$$

$$\text{where } C_v = \text{capacitance of voltmeter} = 8 \times 10^{-12} \text{ F}$$

$$\text{and } C = \text{capacitance of standard capacitor} = 230 \times 10^{-12} \text{ F}$$

From relation (ii), we get

$$\text{Inductance } L = \frac{1}{238 \times 16\pi^2} \text{ H} = 26.6 \mu\text{H.}$$

$$\text{From relation (i), capacitance } C = \frac{1}{4\pi^2 \times 26.6} - 8 = 944 \text{ pF.}$$

Example 23'4. A constant rms voltage of frequency 3 MHz is applied to a coil of inductance L and resistance R , a calibrated variable capacitor C , and a thermojunction all in series. The uncalibrated ammeter is found to show the same scale reading I for the two values of C —namely 37 and 45 pF, one being below and the other above the capacitance C_0 needed to produce maximum current.

The capacitor is now adjusted to a value C_0 , and an added series resistance of 75Ω is found to reduce the current to previous value of I . Determine values of L and R .

Solution. Let the two values of capacitance which produce the same current be C_1 and C_2 .

$$C_1 = 45 \text{ pF} \quad \text{and} \quad C_2 = 37 \text{ pF}.$$

Let the resonance curve be peaked and symmetrical and therefore capacitance required for resonance is :

$$C_0 = \frac{C_1 + C_2}{2} = \frac{45 + 37}{2} = 41 \text{ pF}.$$

$$\text{At resonance, inductance } L = \frac{1}{4\pi^2 f^2 C_0} = \frac{1}{4\pi^2 \times (3 \times 10^6)^2 \times 41 \times 10^{-12}} \text{ H} = 69.2 \text{ } \mu\text{H}.$$

When the capacitance in the circuit is C_1 , the value of current

$$I = \frac{E}{\sqrt{R^2 + (\omega L - 1/\omega C_1)^2}} = \frac{E}{\sqrt{R^2 + \left(2\pi \times 3 \times 10^6 \times 69.2 \times 10^{-6} \times \frac{1}{2\pi \times 3 \times 10^6 \times 45 \times 10^{-12}}\right)^2}} \quad \dots(i)$$

$$\text{At resonance, } I = \frac{E}{R + 75} \quad \dots(ii)$$

Equating (i) and (ii) we get, $R = 70.8 \Omega$.

Example 23'5. Calculate the Q factor and effective resistance of a circuit tuned to a frequency of 1.5 MHz and having an effective capacitance of 150 pF. In this circuit the current falls to 70.7% of its resonant value when the frequency of an emf of constant magnitude injected in series with the circuit deviates from the resonant frequency by 5 kHz.

Solution. The analysis of this problem has been done in Art. 23'6.

$$\text{From Eqn. 23'24, } Q \text{ factor} = \frac{\omega_0}{\omega_1 - \omega_2} = \frac{f_0}{f_1 - f_2}$$

$$\text{Resonant frequency } f_0 = 1.5 \text{ MHz} = 1.5 \times 10^6 \text{ Hz.}$$

The two frequencies at which the current is 70.7% of or $1/\sqrt{2}$ time the current at resonant frequency are :

$$f_1 = (1.5 \times 10^6 + 5 \times 10^3) \text{ Hz, and } f_2 = (1.5 \times 10^6 - 5 \times 10^3) \text{ Hz.}$$

$$\therefore f_1 - f_2 = 10 \times 10^3 \text{ Hz. Hence } Q = \frac{1.5 \times 10^6}{10 \times 10^3} = 150.$$

$$\text{From Eqn. 23'23, resistance } R = \frac{\omega_1 - \omega_2}{\omega_0^2 C} = \frac{f_1 - f_2}{2\pi f_0^2 C} = \frac{10 \times 10^3}{2\pi (1.5 \times 10^6)^2 \times 150 \times 10^{-12}} = 4.7 \Omega$$

23.8. T Networks. T networks are very useful for measurement of inductance, capacitance, resistance and frequency in the high frequency range. These networks employ null techniques.

There are two types of T networks used :

(i) Parallel T network, and (ii) Bridge T network.

23.9. Parallel T Network. Fig. 23'7 (a) shows a parallel T network with source null detector. In fact there are two Ts formed by impedances Z_1, Z_2, Z_3 , and Z_4, Z_5, Z_6 in parallel. The network can be transformed into another form shown in Fig. 23'7 (b) by star delta transformation. A null is

indicated by the detector if the admittance of Z_A and Z_D in parallel is equal to zero. The other impedances i.e., Z_B, Z_C, Z_E, Z_F do not effect the null conditions. Therefore at null point :

$$\frac{1}{Z_A} + \frac{1}{Z_D} = 0 \text{ or } Z_A + Z_D = 0$$

or $Z_A = -Z_D$... (23'25)

But $Z_A = Z_1 + Z_2 + Z_1 Z_2 / Z_3$ and $Z_D = Z_4 + Z_5 + Z_4 Z_5 / Z_6$

Therefore, at null point, $Z_1 + Z_2 + Z_1 Z_2 / Z_3 = -Z_4 - Z_5 - Z_4 Z_5 / Z_6$... (23'26)

A common parallel T network for measurement of frequency is shown in Fig. 23'8. Comparing Fig. 23'8 with circuit of Fig. 23'7 (a),

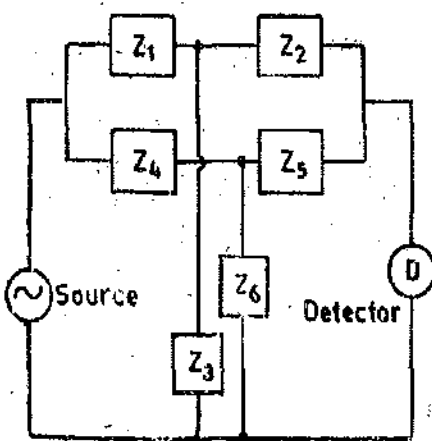

(a)

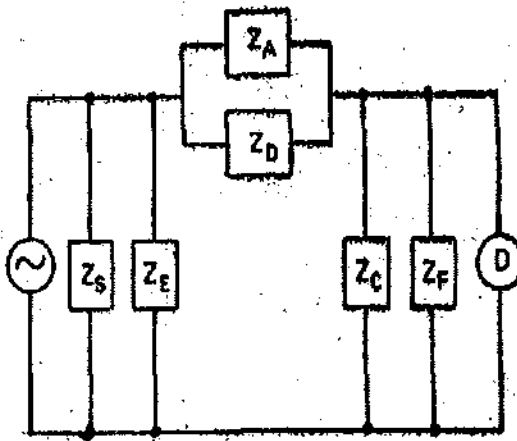

(b)

Fig. 23'7. Parallel T network.

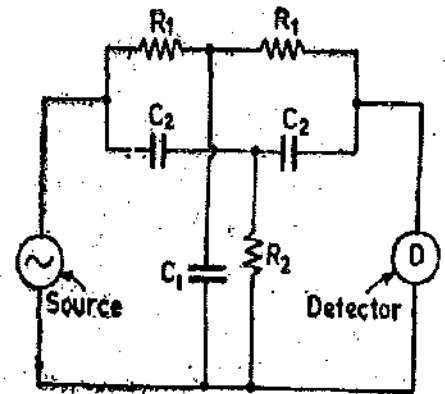

Fig. 23'8. Parallel T network for measurement of frequency.

we have $Z_1 = R_1, Z_2 = R_1, Z_3 = -j/\omega C_1, Z_4 = -j/\omega C_2, Z_5 = -j/\omega C_2$ and $Z_6 = R_2$.

Applying Eqn. 23'26 for null conditions, we have

$$R_1 + R_1 + \frac{R_1^2}{-j/\omega C_1} = \frac{j}{\omega C_2} + \frac{j}{\omega C_2} + \frac{1}{\omega^2 C_2^2 R_2}$$

or $2R_1 + jR_1^2 \omega C_1 = \frac{2j}{\omega C_2} + \frac{1}{\omega^2 C_2^2 R_2}$

Equating real and imaginary terms we get,

$$2R_1 = 1/\omega^2 C_2^2 R_2 \text{ or } \omega^2 = 1/2 R_1 R_2 C_2^2 \text{ ... (23'27)d}$$

and $R_1^2 \omega C_1 = 2/\omega C_2 \text{ or } \omega^2 = 2/R_1^2 C_1 C_2 \text{ ... (23'28)}$

This circuit (Fig. 23'8) therefore can be used to measure frequency. From Eqns. 23'27 and 23'28, we have ; $1/2 R_1 R_2 C_2^2 = 2/R_1^2 C_1 C_2$.

This condition is fulfilled if $R_1 = 4R_2$ and $C_1 = C_2$.

23'10. Bridge T network. Bridge T network is a simplification of parallel T network. If the impedance Z_3 is infinite and the combination of impedances Z_1 and Z_2 is made into a single impedance Z_1' , it becomes a bridge 'T' network. Fig. 23'9 shows a bridge T network.

From Eqn. 23'26 for a bridge T network $Z_1' = -Z_4 - Z_5 - Z_4 Z_5 / Z_6$... (23'29)
as Z_3 is infinite and $Z_1 + Z_2 = Z_1'$.

Fig. 23'10 shows a bridge T network for measurement of effective resistance R , inductance L and Q of a coil.

For this circuit $Z_1' = R + j\omega L, Z_4 = -j/\omega C_1, Z_5 = -j/\omega C_1, Z_6 = R_1$.

At null point we have ; $Z_1' = -Z_4 - Z_5 - Z_4 Z_5 / Z_6$ (Eqn. 23'29)

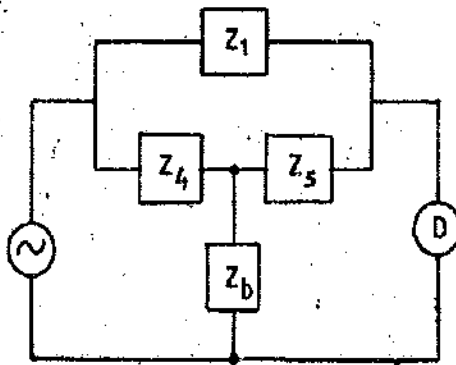

Fig. 23'9. Bridge T network.

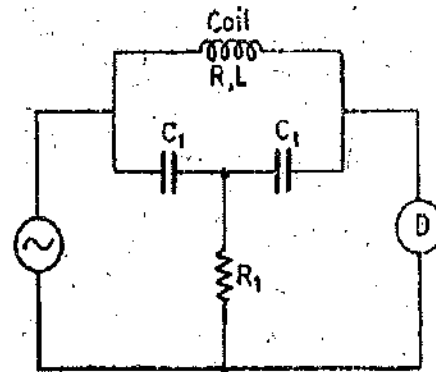

Fig. 23'10. Bridge T network for measurement of effective resistance, inductance and Q.

$$R + j\omega L = \frac{j}{\omega C_1} + \frac{j}{\omega C_1} + \frac{1}{\omega^2 C_1^2 R_1} \quad \text{or} \quad R + j\omega L = \frac{2j}{\omega C_1} + \frac{1}{\omega^2 C_1^2 R_1}$$

Equating real and imaginary terms, we get : $R = 1/\omega^2 C_1^2 R_1$... (23'30)

and $L = 2/\omega^2 C_1$... (23'31)

$$Q = \frac{\omega L}{R} = \frac{2\omega}{\omega^2 C_1} \times \omega^2 C_1^2 R_1 = 2\omega C_1 R_1 \quad \dots (23'32)$$

The T networks have an advantage over ordinary bridge circuits. It is clear that these networks have a common point between source and detector. This point may be earthed and thus the screening of whole of the circuit becomes easy.

Example 23'6. Two variable capacitors C_1 , mechanically coupled so that their capacitances are always equal, are connected in series between terminals A and B to form the series arms of a bridge 'T' network. Their junction is connected through a variable resistor R_1 to the terminal C. A coil of unknown inductance L and resistance R is connected across terminals A and B. The input voltage is applied between A and C, and a detector is connected between B and C. Under what conditions will the detector show an output voltage approaching zero? Evaluate R and L if this balance condition is obtained at a frequency of 5 MHz with $C_1 = 45 \mu\text{F}$ and $R_1 = 4.2 \Omega$.

Solution. The network is similar to the one shown in Fig. 23'10. The analysis of the network is carried out in Art. 23'9.

Eqns. 23'30 and 23'31 give conditions for no output voltage as :

$$R = \frac{1}{\omega^2 C_1^2 R_1} \quad \text{and} \quad L = \frac{2}{\omega^2 C_1}$$

$$R = \frac{1}{4\pi^2 \times (5 \times 10^6)^2 \times (45 \times 10^{-12})^2 \times 4.5} \Omega = 0.115 \text{ M}\Omega$$

and
$$L = \frac{2}{4\pi^2 \times (5 \times 10^6)^2 \times 45 \times 10^{-12}} \text{ H} = 45 \mu\text{H}.$$

23'11. Q Meter. The determination of the storage factor Q is one of the most widely used means in the laboratory for testing radio frequency coils (RFC), inductors and capacitors. The storage factor is equal to $Q = \omega_0 L/R$ where ω_0 is the resonant angular frequency, L is the inductance and R is the effective resistance of a coil. The effective resistance, R , is never determined directly since its value depends upon the value of frequency. As is well known, the value of effective resistance with a.c. differs from its d.c. value on account of skin effect and eddy current losses. Since the value of R varies in a complex manner with frequency; it is indirectly determined by measuring the value of Q .

The Q meter is an instrument which is designed to measure the value of Q directly and as such is very useful in measuring the characteristics of coils and capacitors.

Principle of Working. The principle of working of this useful laboratory instrument is based upon the well-known characteristics of a resonant series R, L, C circuit. Fig. 23.11 (a) shows a coil of resistance R and inductance L in series with a capacitor C .

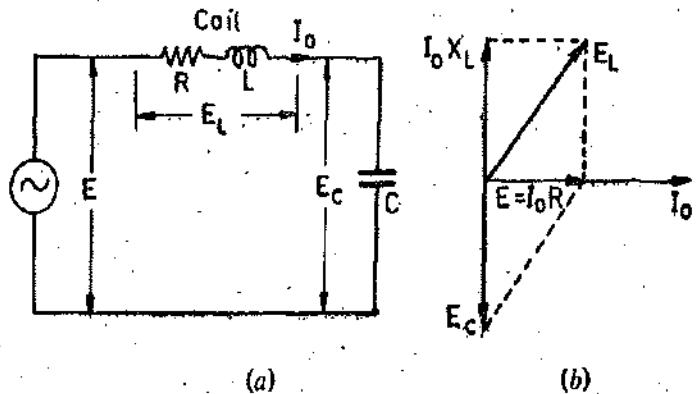

Fig. 23.11. A resonant RLC circuit and its phasor diagram.

At resonant frequency f_0 we have

$$X_C = X_L$$

where capacitive reactance $X_C = -1/2\pi f_0 C$

$$= 1/\omega_0 C \text{ and inductive reactance } X_L = 2\pi f_0 L = \omega_0 L,$$

resonant frequency $f_0 = \frac{1}{2\pi\sqrt{LC}}$ and current $I_0 = \frac{E}{R}$.

The phasor diagram is shown in Fig. 23.11 (b).

Voltage across capacitor, $E_C = I_0 X_C = I_0 X_L = I_0 \omega_0 L$

Input voltage $E = I_0 R \therefore \frac{E_C}{E} = \frac{I_0 \omega_0 L}{I_0 R} = \frac{\omega_0 L}{R} = Q$

or $E_C = QE \dots(23.32)$

Thus the input voltage E is magnified Q times.

If the input voltage E is kept constant, the voltage appearing across the capacitor is Q times E and a voltmeter connected across the capacitor can be calibrated to read the value of Q directly.

Practical Circuit. A practical Q meter circuit is shown in Fig. 23.12. It consists of a self-contained variable frequency RF oscillator. This oscillator delivers current to a low value shunt resistance R_{sh} . This low resistance is of the order of a hundredths of an ohm; a typical value may be

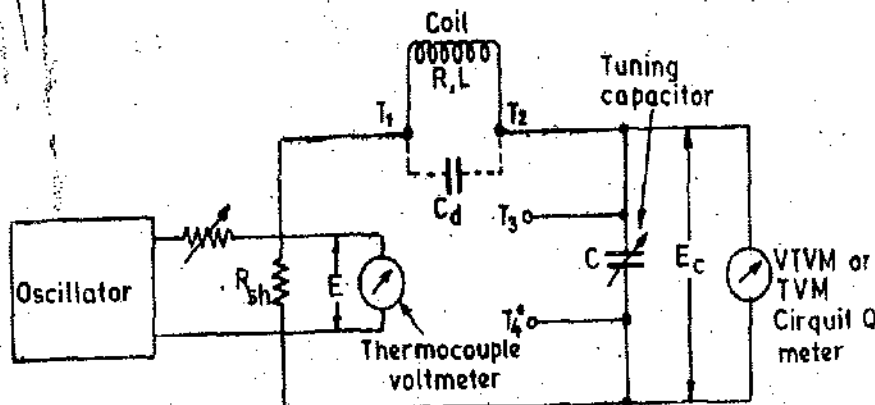

Fig. 23.12. Circuit of a Q meter.

0.02 Ω . Through this resistance a small value of voltage E is injected into the resonant circuit. This voltage is measured by a thermocouple voltmeter. Since the value of shunt resistance is very low, it introduces almost no resistance into the oscillatory circuit and therefore represents a voltage source of magnitude E , with a very small internal resistance. A calibrated standard variable capacitor C is used for resonating the circuit. A VTVM or a TVM is connected across this capacitor. The coil under test is connected to terminals T_1 and T_2 .

Applications :

1. **Measurement of Q .** The circuit for measurement of Q shown in Fig. 23.12. The oscillator is set to the desired frequency and then the tuning capacitor is adjusted for maximum value

of E_0 . As discussed earlier under these conditions $Q = E_0/E$ and if the voltage is kept constant, the voltmeter connected across the capacitor may be calibrated to read the value of Q directly. This measured value of Q is commonly regarded as the Q of the coil under test. However, there is an error. The measured value of Q is the Q of whole the circuit and not of the coil. There are errors caused on account of the shunt resistance and also due to the distributed capacitance of the circuit.

Correction for Shunt Resistance. Measured value, $Q_{meas} = \frac{\omega_0 L}{R + R_{sh}}$

True value, $Q_{true} = \frac{\omega_0 L}{R}$

$$\therefore Q_{true} = Q_{meas} \left(1 + \frac{R_{sh}}{R} \right) \quad \dots(23'3)$$

Thus the measured value of Q is smaller than the true value. Now if coils of high resistance (low Q coils) are being measured, the difference between the two values may be negligible. But when measurements are done on low resistance (high Q) coils, the error caused on this account may be serious.

Correction for Distributed Capacitance. The distributed capacitance or self-capacitance of measuring circuit modifies the true value of Q . The measured value of Q is less than the true value by a factor that depends upon the value of the distributed (self) capacitance and the tuning capacitor. It can be shown that

$$Q_{true} = Q_{meas} \left(1 + \frac{C_d}{C} \right) \quad \dots(23'34)$$

where C_d = distributed or self-capacitance, and C = tuning capacitance.

A method for measurement of distributed (self) capacitance is given later.

2. Measurement of inductance. The value of inductance is given by $L = 1/4\pi^2 f_0^2 C$.

The values f_0 and C are known and therefore the value of inductance may be calculated.

3. Measurement of Effective Resistance. The value of the effective resistance may be computed from the relation $R = \omega_0 L / Q_{true}$.

4. Measurement of Self Capacitance. The self-capacitance is measured by making two measurements at different frequencies. The capacitor is set to a high value, and the circuit is resonated by adjustment of the oscillator frequency. Resonance is indicated by the circuit Q meter. Let the values of tuning capacitor be C_1 and that of frequency be f_1 under these conditions. Therefore,

$$f_1 = \frac{1}{2\pi\sqrt{L(C_1 + C_d)}}$$

The frequency is now increased to twice its initial value and the circuit is resonated again this time with the help of tuning capacitor. Let the value of tuning capacitor be C_2 and that of frequency be f_2 under these conditions. Thus, $f_2 = \frac{1}{2\pi\sqrt{L(C_2 + C_d)}}$

$$\text{Now } f_2 = 2f_1 \quad \therefore \frac{1}{2\pi\sqrt{L(C_2 + C_d)}} = 2 \times \frac{1}{2\pi\sqrt{L(C_1 + C_d)}}$$

$$\text{or distributed capacitance } C_d = \frac{C_1 - 4C_2}{3} \quad \dots(23'35)$$

5. Measurement of Bandwidth. The measurement of bandwidth with a Q meter is similar to the one used for measurement of effective resistance by variation of frequency method given on page 704.

The bandwidth is calculated by using Eqn. 23'24.

6. Measurement of Capacitance. For measurement of capacitance a dummy coil is connected across terminal T_1 and T_2 (Fig. 23.12). The circuit is resonated by varying the value of the tuning capacitor. Let this value be C_1 .

The capacitor under test C_x , is now connected across terminals T_3 and T_4 . This puts the test capacitor in parallel with tuning capacitor. The circuit is resonated again by varying the value of tuning capacitor. Let this value be C_2 . Therefore value of capacitance under test is $C_x = C_1 - C_2$.

This method is similar to the one given in Art. 23.4 on page 701.

Example 23.7. A circuit consisting of a coil, a resistance and a variable capacitor connected in series is tuned to resonance using a Q meter. If the frequency is 500 kHz, the resistance 0.5Ω and the variable capacitor set to 350 pF. Calculate the effective inductance and resistance of the coil, if the Q meter indicates 90.

Solution. At resonance ;

$$\text{Inductance } L = \frac{1}{4\pi^2 f_0^2 C} = \frac{1}{4\pi^2 \times (500 \times 10^3)^2 \times 350 \times 10^{-12}} \text{ H} = 290 \mu\text{H}.$$

Let R be the resistance of coil.

$$\therefore R + 0.5 = \frac{\omega_0 L}{Q} = \frac{2\pi \times 500 \times 10^3 \times 290 \times 10^{-6}}{90} = 10.25 \Omega.$$

Effective resistance of coil $R = 10.25 - 0.5 = 9.75 \Omega$.

Example 23.8. A coil of resistance 10Ω is connected in the Q meter circuit as shown in Fig. 23.12. Resonance occurs at a frequency of 1 MHz with the tuning capacitor set at 65 pF. Calculate the percentage error introduced in the calculated value of Q if a resistance of 0.02Ω is used across the oscillator circuit.

Solution. True value of Q is :

$$Q_{\text{true}} = \frac{1}{\omega CR} = \frac{1}{(2\pi \times 10^6) \times (65 \times 10^{-12}) \times 10} = 245.$$

$$\text{Measured value of } Q_{\text{meas}} = \frac{1}{\omega C(R + 0.02)} = \frac{1}{(2\pi \times 10^6) \times (65 \times 10^{-12}) \times 10.02} = 244.5.$$

$$\therefore \% \text{age error} = \frac{245 - 244.5}{245} \times 100 = 0.2\% \text{ high.}$$

Example 23.9. The self-capacitance of a coil is measured by a Q meter. The circuit is set into resonance at 2 MHz and the tuning capacitor, as a value of 460 pF. The frequency is now adjusted to 4 MHz and resonance conditions are obtained with a tuning capacitor at 100 pF. Calculate the value of self-capacitance of the coil.

Solution. The problem has already been analyzed in previous page.

From Eqn. 23.35, self-capacitance of coil

$$C_s = \frac{C_1 - 4C_2}{3} = \frac{460 - 4 \times 100}{3} = 20 \text{ pF.}$$

Example 23.10. Tests using a Q meter, on a radio tuning coil to find its self-capacitance gave the following results :

1. With a radio coil connected normally, the resonance was obtained at 1 MHz with the tuning capacitor set at 80 pF.

2. With a standard inductor connected in place of the radio coil, resonance was obtained at 3 MHz and this condition was not altered when the radio coil was connected in parallel with the standard inductor. Calculate the self-capacitance of the radio coil.

Solution. Let C_1 = capacitance of tuning capacitor for 1st setting.

ω_1 = angular frequency for 1st setting

$$\therefore \text{Inductance of coil } L = 1/\omega_1^2(C_1 + C_d) \quad \dots(i)$$

In this second setting, the reason for the resonance conditions to remain unchanged is that a very high impedance has been placed in parallel, this being the resonant circuit of the radio coil and its self capacitance. In other words, the radio coil in parallel with its self capacitance is resonant at 3 MHz and thus it may be written

$$L = 1/\omega_2^2 C_d \quad \dots(ii)$$

From (i) and (ii) we have, self capacitance of coil is :

$$C_d = \frac{C_1 \omega_1^2}{\omega_2^2 - \omega_1^2} = C_1 \left(\frac{f_1^2}{f_2^2 - f_1^2} \right) = 80 \times \frac{(1)^2}{(3)^2 - (1)^2} = 10 \text{ pF.}$$

23.12. Vector-Impedance Meter

The measurement of impedance is concerned with both the magnitude (Z) and the phase angle (θ) of a component. In many applications it is not only necessary to determine the magnitude of the impedance, but it may also be important to find the ratio of the reactance to the resistance and whether the reactance is inductive or capacitive.

The measurement of voltage and current is usually sufficient to determine the magnitude of the impedance at frequencies lower than 100 MHz. The phase difference between the voltage waveform and the current waveform indicates whether the component is inductive or capacitive. If the phase angle can be determined, for example, by using a CRO displaying a Lissajous pattern, the reactance can be determined. The properties of a component should be determined at several different frequencies if the component has to be fully specified. Therefore, many measurements are required.

These measurements become highly elaborate and time consuming especially at high frequencies and therefore many steps are required to obtain the desired information.

With the development of instruments, such as the vector impedance meter, it has been possible to simplify impedance measurements over a wide frequency range. The vector impedance meter makes it possible to obtain sweep frequency plots of impedance and phase angle *versus* frequency, thereby providing complete information within the frequency band of interest.

A typical vector impedance meter makes simultaneous measurements of impedance and phase angle over a frequency range of 5 Hz to 500 kHz. The unknown component is simply connected across the input terminals of the instrument, the desired frequency is selected by adjusting the controls provided on the front panel. Two meters on the front panel indicate the magnitude of the impedance and the phase angle.

The operation of the vector-impedance meter is best understood by referring to the block diagram shown in Fig. 23.13. Two measurements are made : (1) the magnitude of the impedance is found by measuring the current through the unknown component when a known voltage is applied across it, or, by measuring the voltage across the component when a known current is passed through it ; (2) the phase angle is determined by finding the phase difference between the voltage across the component and the current through the component.

Referring to the block diagram shown in Fig. 23.13, the meter contains a signal source (a Wien bridge oscillator) with front panel controls for selecting the frequency range and continuous adjustment of the frequency selected. The output of the Wien bridge oscillator is fed to an AGC amplifier which permits accurate gain adjustment of the oscillator output by means of its feedback voltage. This gain adjustment is obtained by an internal control actuated by the setting of the impedance range switch, to which the AGC amplifier output is connected. The impedance range switch is a precision attenuator network which controls the oscillator output voltage and at the same time determines the manner in which the unknown component is to be connected into the circuitry which follows the range switch.

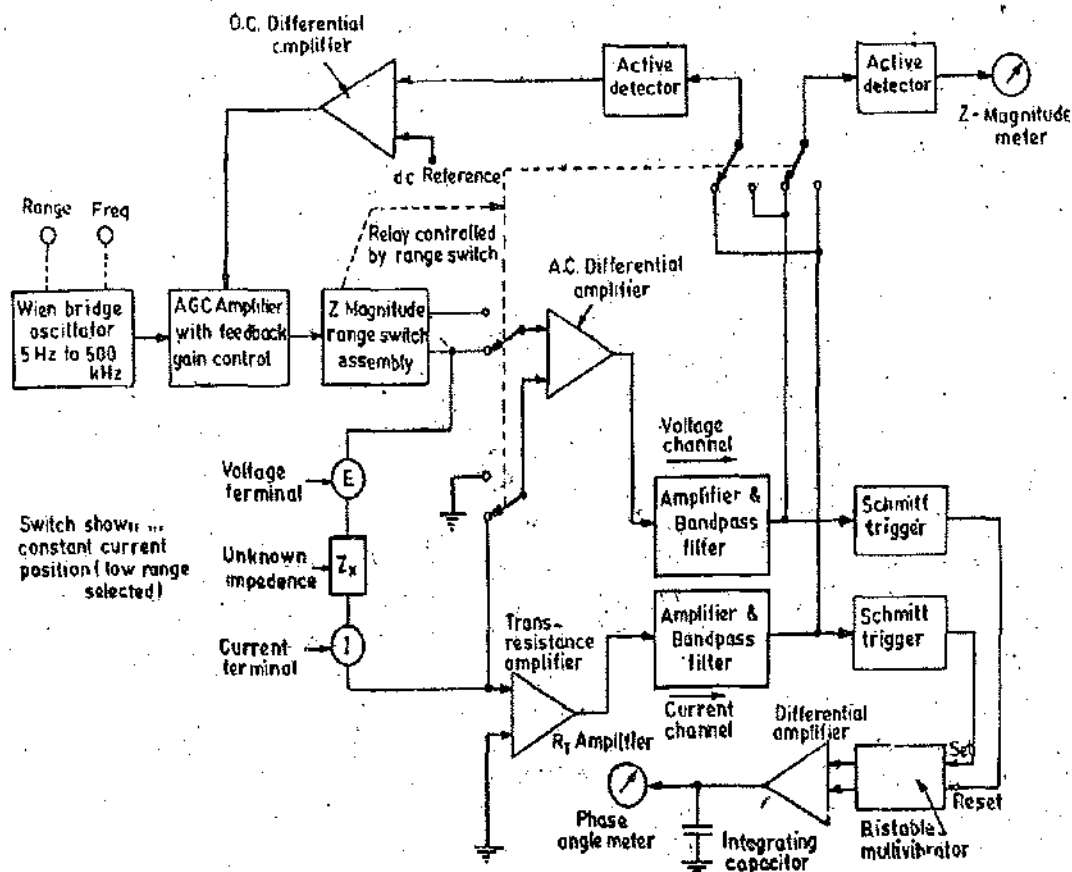

Fig. 23'13. Block diagram of vector impedance meter.

There are two modes in which the impedance switch can operate the instrument. They are : (i) constant-current mode and (ii) constant-voltage mode. The three lower ranges ($\times 1$, $\times 10$, and $\times 100$) operate in the constant-current mode and the four higher ranges ($\times 1$ k, $\times 10$ k, $\times 100$ k, and $\times 1$ M) operate in the constant-voltage mode.

In the constant-current mode, the unknown impedance is connected across the input of the ac differential amplifier. The current supplied to the unknown impedance depends on the setting of the impedance range switch. This current is held constant by the action of the transresistance amplifier (R_T) which converts the current through the unknown impedance to a voltage output equal to the current times its feedback resistance. The transresistance amplifier is an operational amplifier where the output voltage is proportional to the input current. The output of the R_T amplifier is fed to a detector circuit, and compared to a dc reference voltage. The resulting control voltage regulates the gain of the AGC amplifier and hence the voltage applied to the impedance range switch. The output of the ac differential amplifier is applied to an amplifier and filter section which contains high and low-band filters which are changed with the frequency range in order to limit the amplifier bandwidth. The output of the bandpass filter is connected, when selected, to a detector which drives the Z-magnitude meter. Since the current through the unknown impedance is kept constant by the R_T amplifier, the Z-magnitude meter, which measures the voltage across the unknown, impedance defects in proportion to the magnitude of the unknown impedance and is therefore calibrated accordingly.

When the instrument is operating in the constant voltage mode, the two inputs to the differential amplifier are switched. The terminal which was connected to the input of the transresistance amplifier in the constant-current mode is now grounded. The other input of the differential amplifier which was connected to the voltage terminal of the unknown component, is now connected to a point on the Z-magnitude range switch which is held at a constant potential. The voltage terminal of the unknown is connected to this same point of constant potential, or, depending on the setting of the Z-magnitude range switch, to a decimal fraction of this voltage. In any case, the voltage across the unknown is held constant. The current through the unknown impedance is applied to the trans-resistance amplifier which again produces an output voltage proportional to its input current.

The roles of the ac differential amplifier and the transresistance amplifier are now reversed. The voltage output of the R_T amplifier is applied to the detector and then to the Z-magnitude meter. The output voltage of the differential amplifier controls the gain of the AGC amplifier in the same manner that the R_T amplifier did in the constant-current mode.

Phase-angle measurements. These measurements are carried out simultaneously. The outputs of both the voltage channel and the current channel are amplified and each output is connected to a Schmitt trigger circuit. The Schmitt trigger circuits produce a positive-going spike every time that the input sine wave goes through a zero crossing. These positive spikes are applied to a binary phase detector circuit. A bistable multivibrator, a differential amplifier and an integrating capacitor combined together to act as phase detector, a differential amplifier, and an integrating capacitor. The positive-going pulse from the constant current channel sets the multivibrator, and the pulse from the constant voltage channel resets the multivibrator. The "set" time of the multivibrator is therefore determined by the zero crossings of the voltage waveform and the current waveform. The "set", and "reset" outputs of the multivibrator are applied to the differential amplifier, which applies the difference voltage to the integrating capacitor. The capacitor voltage is directly proportional to the zero-crossing time interval and is applied to the phase-angle meter which then indicates the phase difference, between the voltage and current waveforms in degrees.

23.13. Measurement of Frequency. Frequency measurements are done by two types of methods. (i) Resonance methods, and (ii) Heterodyne methods.

1. Resonance Methods. The frequency may be determined by resonance methods elaborated earlier. For this purpose bridge circuits (like Wien's bridge), parallel T or bridge T networks may be used.

2. Heterodyne Methods. The frequency may be measured by heterodyning the unknown frequency with a known frequency. The output of the mixer is the difference of the two frequencies i.e. the beat frequency. If the source of known frequency is a wave meter and if its frequency is adjusted to a value near to that of the unknown frequency, beats between the two cause an audible note in the telephone of the wavemeter. The wavemeter frequency is then adjusted until the pitch of the note becomes inaudible. Under these conditions, the frequency of the wavemeter is within ± 25 Hz of the unknown frequency. Thus the unknown frequency can be known from the calibration of the wavemeter.

UNSOLVED PROBLEMS

1. A capacitor of capacitance 245 pF produces resonance at an angular frequency of 5×10^6 rad/s, while a capacitor of capacitance 50 pF produces resonance with the second harmonic of this frequency. Calculate :
(a) the inductance, and (b) the self capacitance of the coil. [Ans. 154 μ H, 15 pF]

2. With a suitable standard inductor connected to a Q-meter, resonance is obtained with an angular frequency ω with capacitor setting C_1 ; the indicated Q factor is Q_1 . The unknown impedance is connected in series with the standard inductor and resonance re-established by resetting the capacitor to C_2 , the corresponding Q factor being Q_2 . Calculate :

(a) the resistive, and (b) reactive components of the unknown impedance when
 $C_1 = 208$ pF, $Q_1 = 170$, $C_2 = 185.5$ pF and $Q_2 = 52$.

The frequency is 159 kHz.

[Ans. 35 Ω , 584 Ω]

3. A test coil is connected across a calibrated loss free variable capacitor having in parallel with it a VTVM of input capacitance 3 pF. A constant current, of varying frequency is passed through an injector coil loosely coupled to the test coil, and at each frequency the capacitor is adjusted to produce a maximum reading on the voltmeter. The readings are as follows :

Frequency kHz	200	300	400	500	600
Capacitance pF	345	145	75	43	25
Maximum voltage, V	4	—	—	—	16

Determine:

(a) the inductance of the test coil, (b) its self capacitance, and (c) the percentage increase in its resistance as the frequency varies from 100 kHz to 600 kHz. [Ans. 1.732 mH, 12 pF, 125%]

4. A coil of unknown impedance in series with a capacitor of 224 pF and an ammeter of negligible impedance was connected to a variable frequency of constant voltage and negligible impedance. The frequency was adjusted both above and below resonant frequency. Till the reading of ammeter was reduced to 70.7% of its value at resonance. This occurred at frequencies of 876 and 892 kHz. Determine effective resistance, inductance and Q of the coil. [Ans. 14.5 Ω , 0.145 mH, 55.3]

5. The effective resistance of a coil at a frequency of 0.2 MHz is measured by the reactance variation method. The coil is connected in series with a calibrated variable capacitor and a 10 Ω resistor. A constant emf at 0.2 MHz is injected into the circuit. A VTVM connected across the resistor is used to indicate resonance. The capacitor settings to reduce the resonant current by one half are 150 pF and 170 pF. Calculate the effective resistance of the coil. [Ans. 170 Ω]

6. A coil of unknown impedance in series with a capacitor of capacitance 0.02 μ F and an ammeter of negligible impedance was connected to a variable frequency source having constant voltage. The frequency was adjusted both above and below resonance until the reading of the ammeter was reduced to 0.8 of the value at resonance. This occurred at frequencies of 0.97 and 1.01 MHz. Find the inductance and resistance of the coil. [Ans. 1.29 μ H; 0.424 Ω]

7. A test on a radio tuning coil, using Q meter, gave the following results:

(a) With a radio coil connected normally, resonance was obtained at a frequency of 1 MHz with the Q meter capacitor set at 480 pF.

(b) With standard inductor connected in place of the radio coil, the resonance was obtained at 5 MHz and this condition was not altered when the coil was connected in parallel with the standard inductor. Calculate the self capacitance of radio coil. [Ans. 20 pF]

8. A Q meter gave the following readings during a certain test on a coil:

$$Q=250, \quad C=160 \text{ pF}, \quad f=750 \text{ kHz.}$$

A VTVM was then connected across the standard capacitor and resonance re-established. The corresponding readings now become

$$Q=150, \quad C=150 \text{ pF}, \quad f=750 \text{ kHz.}$$

Calculate for the VTVM:

(a) the input resistance, and (b) the input capacitance.

[Ans. 496 k Ω , 10 pF]

9. A coil was tested using a Q meter and following information was obtained. At a frequency of 3 MHz, the value of capacitance to give maximum voltage across the capacitor was 251 pF while at 6 MHz frequency it was 50 pF. Calculate the self capacitance of the coil. [Ans. 17 pF]

10. A coil with a resistance of 0.1 Ω is connected in a Q meter circuit as shown in Fig. 23.12. Resonance occurs when the oscillator frequency is 40 MHz and the tuning capacitor is set at 135 pF. Calculate the percentage error introduced in the calculated value of Q by a 0.02 Ω shunt resistance connected across the oscillator circuit. Comment upon the result. [Ans. 17%]

PART II
ELECTRICAL & ELECTRONIC
INSTRUMENTATION

Dynamic Characteristics of Instruments and Instrumentation Systems

24.1. Dynamic Response

An introduction to dynamic response and dynamic characteristics has already been given in Art. 2.30 (pages 31–33). In this chapter the dynamic response of instruments and instrumentation systems for various types of input signals is examined in details.

24.2. Dynamic Behaviour

The dynamic behaviour of a system is studied in two domains: (i) Time Domain and (ii) Frequency Domain.

24.2.1. Time Domain Analysis. In this analysis the dynamic behaviour of the system for various types of inputs is studied with respect to time 't' as the independent variable. In other words, the dynamic response of the system to different types of inputs, which are a function of time is analyzed at different intervals of time after the application of input signal.

24.2.2. Frequency Domain Analysis. The system is subjected to various types of time varying signals. According to Fourier analysis, these signals can be broken down to various sinusoidal signals having different frequencies. Also the system may be subjected to inputs which vary periodically with time. Thus it is important to analyse the system behaviour with frequency as the independent variable. The analysis with frequency as independent variable is called Frequency Domain Analysis.

24.3. Mathematical Models of Instrumentation Systems

An instrumentation system is a physical system. A physical system is defined as collection of physical objects connected together to serve an objective. An Instrumentation System is an assemblage of diverse physical objects interconnected to measure, analyse and control electrical, fluidic, thermal and other physical quantities.

The first step in modelling a system is to obtain its physical model. It is impossible to obtain a physical model of an instrumentation system (or for that matter, of any system) which incorporates all the complexities of the system. However, idealized assumptions are made in order to have a simplified version of the model for the purposes of analysis and synthesis. The model based upon certain idealized assumptions is called a physical model.

The next step in modelling is to obtain a mathematical model from the conceived physical model. A mathematical model is a mathematical representation of the physical model. A mathematical model is achieved from a physical model by utilizing the physical laws of the process.

After a mathematical model of a system has been obtained, the system is solved for various types of inputs. The resulting output response is called the dynamic response of the system.

24.4. Linear and Non-Linear Systems

The mathematical model of a system is linear, if it obeys the laws of superposition and homogeneity. Suppose the system is subjected to inputs,

$x_1(t), x_2(t), \dots, x_n(t)$ and the corresponding outputs are :

$y_1(t), y_2(t), \dots, y_n(t)$ respectively,

then the system response to the linear combination of these inputs

$$a_1x_1(t) + a_2x_2(t) + \dots + a_nx_n(t) \quad \dots(24'1)$$

is given by the linear combination of the outputs e.g.

$$a_1y_1(t) + a_2y_2(t) + \dots + a_ny_n(t) \quad \dots(24'2)$$

where a_1, a_2, \dots, a_n are constants.

The property of homogeneity means that the inputs $x_1(t), x_2(t), \dots, x_n(t)$ are of the same form. Also the outputs $y_1(t), y_2(t), \dots, y_n(t)$ are of the same form.

The mathematical models describing a system are depicted by differential equations. A mathematical model is described as Linear if the co-efficients of the differential equation describing it are either constants or are a function of the time (which is the independent variable).

In case the principles of superposition and homogeneity are not complied with and also in case the differential equation describing the mathematical model has co-efficients which are a function of dependent variable, then the system is called non-linear. There are two further classifications of linear systems. They are :

- (i) Linear time invariant systems, and (ii) Linear time variant systems.

24'4.1. Linear Time Invariant System. In case the differential equation describing a system has constant co-efficients, it is called a Linear time invariant system.

24'4.2. Linear Time Variant System. If the differential equations describing a system have co-efficients which are a function of time (the independent variable), the system is called a time variant system.

24'5. Analysis of Linear Systems

Powerful mathematical tools like the Laplace and Fourier transforms are available for analysis of linear systems. Unfortunately most of the instrumentation systems are not linear in nature and therefore assumptions have to be made to make them linear so that their analysis could be carried out. Linearizing a non-linear system, no doubt, results in simplicity but at the same time results in loss of accuracy. Hence a compromise has to be made between simplification of the model and the accuracy of results obtained from it.

In summary, the approach to dynamic systems problem can be listed as follows :

- (1) Define the instrumentation system and its components ;
- (2) Build up the physical model and list the necessary assumption made ;
- (3) Formulate the mathematical model and describe the assumptions made ;
- (4) Write down the differential equations describing the model ;
- (5) Solve the equations for the desired output variables ;
- (6) Examine the solutions and assumptions ;

(7) Apply the necessary corrections to subvert the idealized corrections made in both physical and mathematical models ;

(8) Re-analyze and re-design till the solutions obtained are compatible with the results expected of the actual system.

24'6. Electric Networks

An $R-L-C$ circuit is shown in Fig. 24'1. Using Kirchhoff's voltage law, the equations describing the dynamics are written as :

Input voltage :

$$e = L \frac{di(t)}{dt} + Ri(t) + \frac{1}{C} \int i(t) dt \quad \dots(24'3)$$

or
$$e = L \frac{d^2q(t)}{dt^2} + R \frac{dq(t)}{dt} + \frac{q(t)}{c} \quad \dots(24'4)$$

where q = charge = $\int i(t) dt$. and i = current = $\frac{dq(t)}{dt}$.

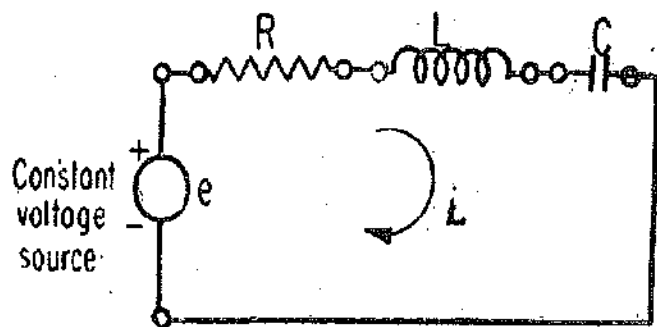

Fig. 24'1. A series $R-L-C$ circuit.

24.7. Mechanical Systems

The motion of mechanical elements can be described in various dimensions as :

(i) translational, (ii) rotational and (iii) a combination of translational and rotational systems.

The equations governing the motions of mechanical systems are often directly or indirectly formulated from Newton's law of motion.

24.7.1. Mechanical Translational Systems

Translation is defined as a motion that takes place along a straight line. The three basic elements involved in translational motion are :

(i) mass, (ii) spring and (iii) friction.

In this analysis, we neglect the effects of static friction, coulomb friction and other friction terms which exhibit a non-linear behaviour. Fig. 24.2 shows a simple spring-mass-damper system where the applied force $f(t)$ is a function of time. This force is resisted by the forces exerted by the three elements listed above.

(i) Mass. The mass M is an inertial element. A force applied to a mass produces an acceleration. The reaction force f_M is equal and opposite to the product of the mass and acceleration and acts in a direction opposite to the applied force.

$$\therefore f_M = M \times a = M \frac{d^2x}{dt^2} \text{ newton} \quad \dots(24.5)$$

where

$$f = \text{mass ; kg, } x = \text{displacement ; m,}$$

$$v = \frac{dx}{dt} = \text{velocity ; m/s, } a = \frac{d^2x}{dt^2} = \text{acceleration ; m/s}^2.$$

The reaction force f_M is a function of time and acts through mass M .

(ii) Stiffness. The stiffness, K , provides a restoring force as represented by a spring. When a force is applied to a spring, the reaction force, f_k on each end of the spring is the same and is equal to the product of the stiffness K , and the amount of deformation, x , of the spring.

$$f_k = Kx \text{ newton} \quad \dots(24.6)$$

where $K = \text{stiffness constant ; N/m.}$

(iii) Viscous Friction. The co-efficient of viscous friction or the damping constant D characterises that the element absorbs energy or in other words, the element is an energy dissipating element.

$$\text{The reaction damping force is } f_D = D \frac{dx}{dt} \text{ newton} \quad \dots(24.7)$$

The force $f(t)$ is resisted by force $f_M(t)$, $f_k(t)$ and $f_D(t)$.

We can write the equation of motion as

$$f(t) = f_M(t) + f_D(t) + f_k(t)$$

$$\text{or } f(t) = M \frac{d^2x(t)}{dt^2} + D \frac{dx(t)}{dt} + Kx(t) \quad \dots(24.8)$$

This can be written in another form

$$f(t) = m\ddot{x} + D\dot{x} + Kx \quad \dots(24.9)$$

where

$$\ddot{x} = \frac{d^2x(t)}{dt^2}, \dot{x} = \frac{dx(t)}{dt} \text{ and } x = x(t)$$

24.7.2. Mechanical Rotational Systems. The rotational motion of a body may be defined as motion about a fixed axis. Rotational systems are similar to translational systems except for the basic differences that torque equations are written in place of force equations and the displacement, velocity and acceleration terms are angular quantities. The three basic elements involved are inertia, torsional stiffness and viscous friction. An elementary mechanical rotational system is shown in Fig. 24.3. Let us analyze the systems considering its basic elements.

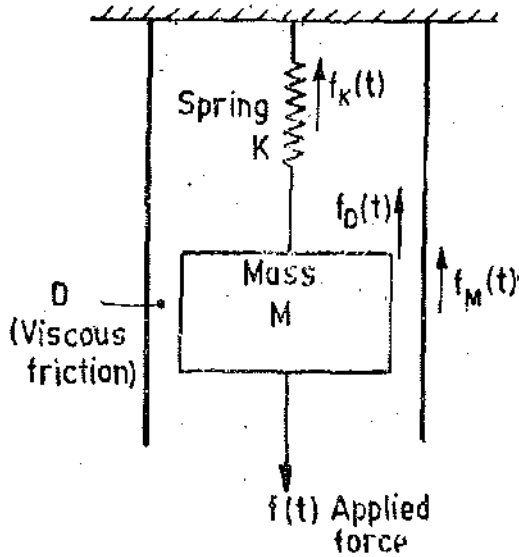

Fig. 24'2 Spring-mass-damper system.

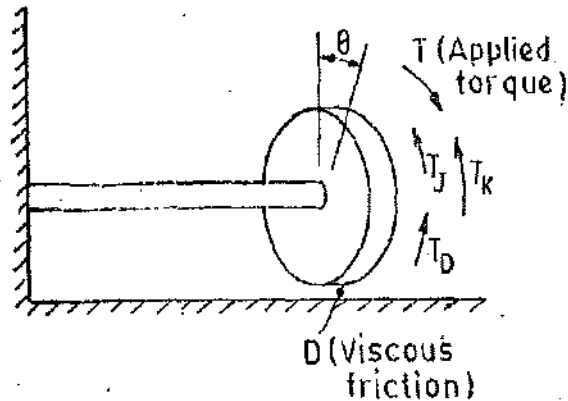

Fig. 24'3. Mechanical rotational system.

(i) **Inertia.** The torque applied to a body having a moment of inertia, J , produces an angular acceleration.

The reaction torque produced by inertia is :

$$T_I(t) = J\alpha(t) = \frac{d\omega(t)}{dt} = J \frac{d^2\theta(t)}{dt^2} \quad \dots(24'10)$$

where T_I = inertia torque ; N-m, J = moment of inertia ; kg-m²,
 α = angular acceleration ; rad/s², ω = angular velocity ; rad/s,
 θ = angular twist ; rad.

(ii) **Torsional Torque.** When a torque is applied to an elastic mass, it is twisted through an angle θ . The angular torque is transmitted through the spring action and appears as a counter torque at the other end. The reaction spring or torsional torque, T_k , is equal to the product of the torsional constant, K , and θ the angular twist.

$$\text{Torsional torque } T_k(t) = K\theta(t) \text{ N-m} \quad \dots(24'11)$$

where K = stiffness or torsional constant, N-m/rad.

(iii) **Damping Torque.** Damping occurs whenever a body moves through a fluid. In order to produce motion of the body, a torque must be applied to overcome the reaction torque due to damping. The torque due to damping is :

$$T_D(t) = D\omega(t) = \frac{Dd\theta(t)}{dt} \text{ N-m} \quad \dots(24'12)$$

where D = damping constant or viscous friction constant ; N-m/rad-s⁻¹.

The differential equation describing the dynamics of a mechanical rotational system is :

$$T(t) = J\alpha(t) + D\omega(t) + \theta K(t) \\ = J \frac{d^2\theta(t)}{dt^2} + D \frac{d\theta(t)}{dt} + K\theta(t) \quad \dots(24'13)$$

$$= J \ddot{\theta} + D\dot{\theta} + K\theta \quad \dots(24'14)$$

$$\text{where } T(t) = \text{applied torque ; N-m.} \quad \dots(24'15)$$

24'8. Analogous Systems

Comparing Eqn. 24'8 for the mechanical translational system shown in Fig. 24'2 and Eqn. 24'13 for the mechanical rotational system shown in Fig. 24'3, it is found that they have an identical form. The systems which are defined by identical differential equations are called analogous systems. Let us compare Eqn. 24'8 for mechanical translational system and Eqn 24'13 for mechanical rotational system with that of a series R-L-C circuit (Eqn. 24'4) supplied by a constant

voltage source. It is found that force and torque in the mechanical systems are analogous to voltage e . The analogy based upon this description is called a force-voltage analogy. A list of analogous variables based upon this analogy are given in Table 24.1.

TABLE 24.1
Force Voltage Analogy

Mechanical Translational System	Mechanical Rotational System	Electrical System
Force, F	Torque, T	Voltage, E
Mass, M	Moment of inertia, J	Inductance, L
Viscous friction constant, D	Viscous friction constant, D	Resistance, R
Spring stiffness, K	Torsional stiffness, K	Reciprocal of capacitance, $1/C$
Displacement, x	Angular displacement, θ	Charge, Q
Velocity, \dot{x}	Angular velocity, $\dot{\theta}$	Current, i

The concept of analogous systems is a very useful technique in the study of all types of systems which may be mechanical, thermal, fluidic or pneumatic in nature. They can be converted into analogous electrical quantities and the system behaviour can be studied and analyzed on an electrical analog computer.

24.9. Thermal Systems

Thermal systems are those which involve the transfer of heat from one substance to another. Thermal systems may be analyzed in terms of resistance and capacitance. Let us consider a simple thermal system shown in Fig. 24.4. The idealized assumptions made in the system are :

(i) The tank is lined with a perfect heat insulator and thus there is no heat loss to the surrounding air.

(ii) There is no heat storage in thermal insulation of the tank.

(iii) The tank is kept at a uniform temperature with the help of a stirrer and therefore a single temperature can be used for the entire liquid in the tank and the outflowing liquid.

Let

θ_i = steady-state-temperature of inflowing liquid ; $^{\circ}\text{C}$,

θ_o = steady-state-temperature of outflowing liquid ; $^{\circ}\text{C}$,

Q = steady-state liquid flow rate ; kg/s,

M = mass of liquid in tank ; kg,

s = specific heat of liquid ; $\text{J}/\text{kg}^{\circ}\text{C}$,

R = thermal resistance ; $^{\circ}\text{C}/\text{J}-\text{s}$,

H = steady state heat input rate ; J/s.

and

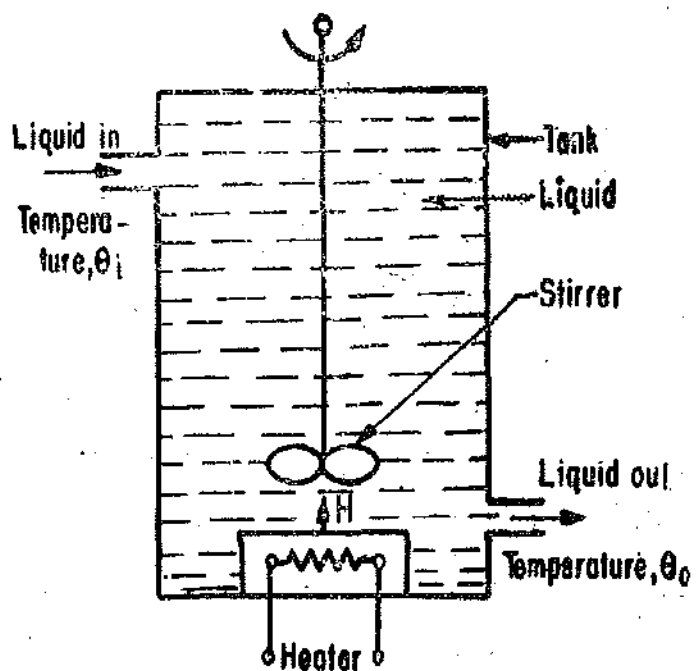

Fig. 24.4 Thermal system.

C = thermal capacitance ; $\text{J}/^{\circ}\text{C}$,

Assume that the temperature of the inflowing liquid is kept constant and that the heat input rate is changed from H to $H+h_1$ where h_1 represents a small change in heat flow rate. The heat outflow rate will then gradually change from H to $H+h_2$. The temperature of the outflowing liquid will also be changed from θ_0 to $\theta_0+\theta$, where θ is the change in temperature of outflowing liquid, °C.

The steady state conditions are disturbed. Some of the heat will be stored in the liquid and some of the heat will result into increased temperature of the liquid outflowing from the tank.

$\therefore h_1 = h_1 + h_2$ where h_1 = rate of heat storage in the tank ; J/s,

and h_2 = rate of heat outflow from the tank ; J/s.

Now rate of heat storage in the tank = $M_s \frac{d\theta}{dt}$... (24.16)

= $C \frac{d\theta}{dt}$... (24.17)

where C = thermal capacitance = M_s ; J/°C ... (24.18)

Now $h_2 = Q_s \theta$... (24.19)

Thus we can write : $h_1 = C \frac{d\theta}{dt} + Q_s \theta = C \frac{d\theta}{dt} + \frac{\theta}{R}$... (24.20)

where, thermal resistance $R = \frac{1}{Q_s}$... (24.21)

or $h_1 R = RC \frac{d\theta}{dt} + \theta$

$RC \frac{d\theta}{dt} + \theta = h_1 R$... (24.22)

The thermal quantities analogous to electrical quantities are given in Table 24.2.

TABLE 24.2

Analogous Quantities in Thermal and Electrical Systems

S No.	Electrical Systems	Thermal Systems
1.	Charge ; C	Heat flow ; J
2.	Current ; A	Heat flow rate ; J/s
3.	Voltage ; V	Temperature ; °C
4.	Resistance ; Ω	Resistance ; °C/(J-s)
5.	Capacitance ; farad	Capacitance ; J/°C

24.10. Transfer Function

Transfer function plays an important role in the characterization of linear time invariant systems. In fact transfer function along with block diagrams and signal flow graphs forms the basis of representing the input-output relationships of linear time invariant systems. This is because in so many other areas of engineering applications like circuit theory, vibration theory, automatic control theory, aerospace theory and control, and stability studies, the most widely used mathematical model for analysis of system dynamic response is described with the help of linear differential equations involving constant co-efficients (Linear time invariant).

The starting point of defining the transfer function is the differential equation which defines the dynamics of the system. Consider a linear time-invariant system which is defined by an n th order differential equation :

$$\begin{aligned}
 a_n \frac{d^n c(t)}{dt^n} + a_{n-1} \frac{d^{n-1} c(t)}{dt^{n-1}} + \dots + a_1 \frac{dc(t)}{dt} + a_0 c(t) \\
 = b_m \frac{d^m r(t)}{dt^m} + b_{m-1} \frac{d^{m-1} r(t)}{dt^{m-1}} + \dots + b_1 \frac{dr(t)}{dt} + b_0 r(t)
 \end{aligned} \quad \dots(24'23)$$

where $c(t)$ = output variable, $r(t)$ = input variable, and t = time.

$a_0, a_1, \dots, a_{n-1}, a_n$ and $b_0, b_1, \dots, b_{m-1}, b_m$ are constants which represent combinations of system parameters with $n \geq m$.

The differential equation 24'23 represents a complete description of the system between the input $r(t)$ and the output $c(t)$. Once the input and the initial conditions of the system are specified, the output response may be obtained in time domain by solution of differential equation.

The transfer function of a linear time invariant system is defined to be the ratio of Laplace transform of the output variable to the Laplace transform of the input variable under the conditions that all initial conditions are zero. Thus in order to obtain the transfer function of a linear system represented by Eqn. 24'23 the Laplace transform of both sides of the equation is taken assuming all conditions to be zero. Hence,

$$(a_n s^n + a_{n-1} s^{n-1} + \dots + a_1 s + a_0) C(s) = (b_m s^m + a_{m-1} s^{m-1} + \dots + b_1 s + b_0) R(s).$$

Therefore, the transfer function of the system is :

$$G(s) = \frac{C(s)}{R(s)} = \frac{b_m s^m + b_{m-1} s^{m-1} + \dots + b_1 s + b_0}{a_n s^n + a_{n-1} s^{n-1} + \dots + a_1 s + a_0} \quad \dots(24'24)$$

The dynamics of a mass-spring-damper system has been described earlier in Art. 24'7'1. The differential equation is :

$$f(t) = M \ddot{x}(t) + D \dot{x}(t) + Kx(t)$$

where displacement $x(t)$ is the output variable, and force $f(t)$ is the input variable.

Taking the Laplace transform of each term of the equation and assuming that all initial conditions are zero, we have :

$$F(s) = Ms^2 X(s) + DsX(s) + KX(s)$$

$$\therefore \text{Transfer function } G(s) = \frac{X(s)}{F(s)} = \frac{1}{Ms^2 + Ds + K} \quad \dots(24'25)$$

The transfer function is an expression in s domain which relates the output to the input for a linear time invariant system. Although it describes the input-output behaviour of the system, but it does not furnish any information regarding the internal structure of the system. In order to study the dynamics of a system, the process done on the input to get the output (for the purpose of analysis), is in the form of a mathematical expression which is a representation of a physical system. Thus when the transfer function of a physical system is determined, the system can be represented by a block, which is a short-hand pictorial representation of cause and effect relationship existing between input and output of the system.

The transfer function as shown by a block represents a functional operation of a system which can be more easily visualized through a block diagram than with the help of differential equations.

Thus a system can be represented as :

$$C(s) = G(s)R(s)$$

24'11. Sinusoidal Transfer Function

The sinusoidal transfer function is used for carrying out studies of a system in frequency

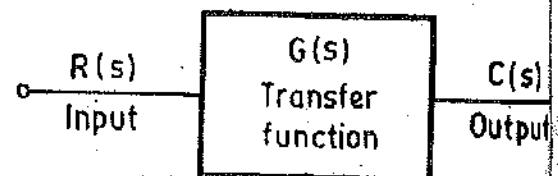

Fig.24'5. Block diagram representation of a system.

domain. The study of quality of measurement systems involves the steady state response of the system when a sinusoidal input is applied to it. The steady state response of a system to a sinusoidal input is obtained by replacing s with $j\omega$ in the transfer function of the system.

The general sinusoidal transfer is :

$$G(j\omega) = \frac{C(j\omega)}{R(j\omega)} = \frac{b_m(j\omega)^m + b_{m-1}(j\omega)^{m-1} + \dots + b_1(j\omega) + b_0}{a_n(j\omega)^n + a_{n-1}(j\omega)^{n-1} + \dots + a_1(j\omega) + a_0}$$

The transfer function of a mass spring-dashpot system is :

$$G(s) = \frac{X(s)}{F(s)} = \frac{1}{Ms^2 + Ds + K}$$

The sinusoidal transfer-function is written as :

$$G(j\omega) = \frac{X(j\omega)}{F(j\omega)} = \frac{1}{M(j\omega)^2 + D(j\omega) + K} \quad \dots (24'26)$$

24'12. Order of a System. The highest power of complex variable s in the denominator for the transfer function of a system determines its order. The mass-dashpot-damper system as shown in Fig. 24'2 has a transfer function whose denominator with a complex variable of highest power 2. Therefore, it is known as a 2nd order system.

TIME DOMAIN RESPONSE

24'13. Introduction The measurement systems may be subjected to any type of input. The type of input signals cannot be known fully ahead of time. In almost all applications the signals are random in nature. Therefore, it becomes difficult to express the actual input signals mathematically by simple equations. Dynamic behaviour of measurement systems can be studied with the help of certain standard signal. These standard signals are :

- (i) Step input, (ii) Ramp input, (iii) Parabolic input and (iv) Impulse input.

The above signals are used for studying dynamic behaviour in the time domain. These signals are shown in Fig. 24'6. For studies in frequency domain, steady state response to a sinusoidal input signal yields a great deal of information. This is because all actual inputs can be thought of consisting a band of frequencies ranging from zero onwards (All types of signals can be broken into sum of a series of sinusoidal signals according to Fourier Series).

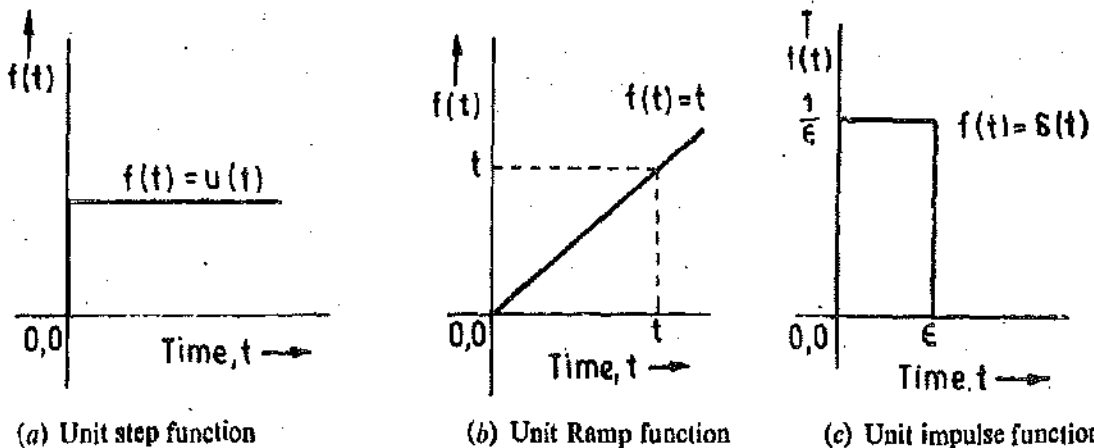

Fig. 24'6. Standard Input Signals.

When system studies are carried out in time domain, the dynamic behaviour of the system depends upon the system poles and not on type of input. Therefore the system behaviour to any kind of inputs can be predicted by studying its response to one of the standard signals. The standard input chosen for this purpose is a step input.

24'14. Zero Order System. A zero order instrument is one where the highest order of the derivative describing the system behaviour is zero. Therefore from Eqn. 24'23, a zero order instrument is described by:

$$a_0 c(t) = b_0 r(t) \quad \dots(24'27)$$

where $c(t)$ = output, $r(t)$ = input and a_0 and b_0 are constants.

Examining Eqn. 24'27, it is observed that it is a simple algebraic equation.

Any instrument or system that closely obeys Eqn. 24'27 over its entire operating range is defined as a zero order instrument.

We can rewrite Eqn. 24'27 as : output $c(t) = \frac{b_0}{a_0} r(t) = S r(t)$...(24'28)

where S = static sensitivity (steady state gain) = $\frac{b_0}{a_0}$...(24'29)

Now Eqn. 24'28 is a simple algebraic equation and therefore no matter how the input $r(t)$ varies with time, the output follows it perfectly and faithfully. This means that neither there is a distortion nor any time lag. A linear potentiometer shown in Fig. 24'7 (a) may be considered as a zero order instrument.

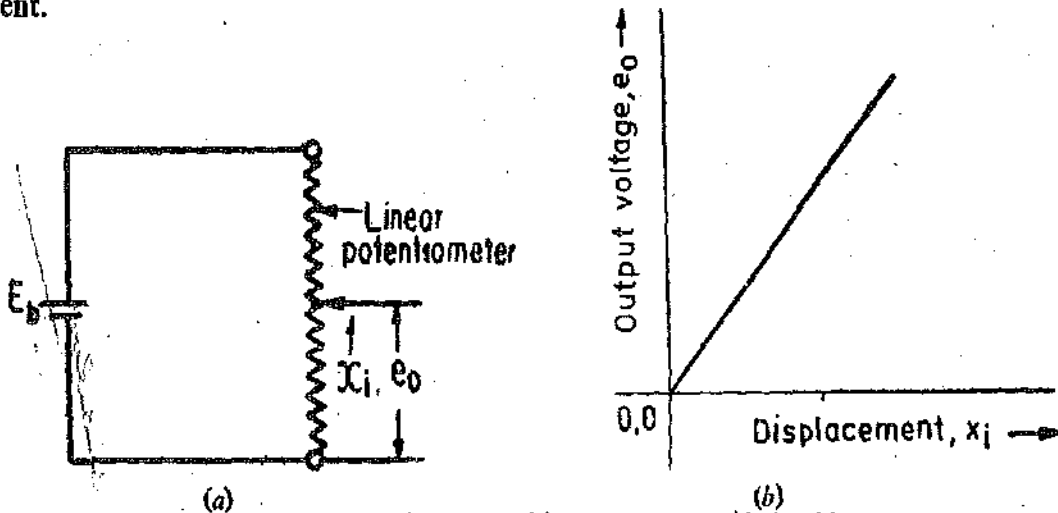

Fig. 24'7. Linear potentiometer and its input-output relationship.

Suppose

E_b = supply voltage to potentiometer ; V,

L = length of potentiometer ; m,

$x_i(t)$ = displacement of sliding contact at any time t ; m,

$e_o(t)$ = output voltage at any time t ; V.

and

Since the resistance of potentiometer is linearly distributed along its length, the voltage per unit length = E_b/L .

\therefore Output voltage $e_o(t) = (E_b/L)x_i(t) = S x_i(t)$...(24'30)

where sensitivity $S = \frac{E_b}{L}$ V/m. ...(24'31)

From Eqn. 24'31 it is clear that a linear relationship exists between the displacement and the output voltage as shown in Fig. 24'7 (b). In fact a resistance potentiometer is not truly a zero order system. The above analysis is based upon the following assumptions :

(i) The potentiometer has infinite number of turns and therefore we get an absolute linear relationship displacement x_i and output voltage e_o . In actual practice the potentiometers have a finite number of turns and therefore we get a stepped curve depicting the relationship between output voltage and the input displacement. This is shown in Fig. 24'8.

(ii) The measuring device connected at the output terminals has an infinite impedance. However, in actual practice the output device has a finite impedance due to which there are loading effects. This results in a non-linear relationship between the input and the output.

(iii) The winding of potentiometer is not purely resistive. There are inductive and capacitive effects and hence the simplified resistive model is not valid.

(iv) There are mechanical loading effects due to inertia of the sliding contact and friction.

Thus owing to above reasons, even a resistive potentiometer cannot be considered as a zero order instrument, but it is one of the systems which closely approximate a zero order system.

24.15. First order Systems. The highest order of derivative in first order systems is one. First order systems are commonly found in measurement systems. Let us analyze a common R-C circuit which is a typical example of a first order system. Fig. 24.9 shows a series R-C circuit wherein a step input of E_i volt is applied to the circuit.

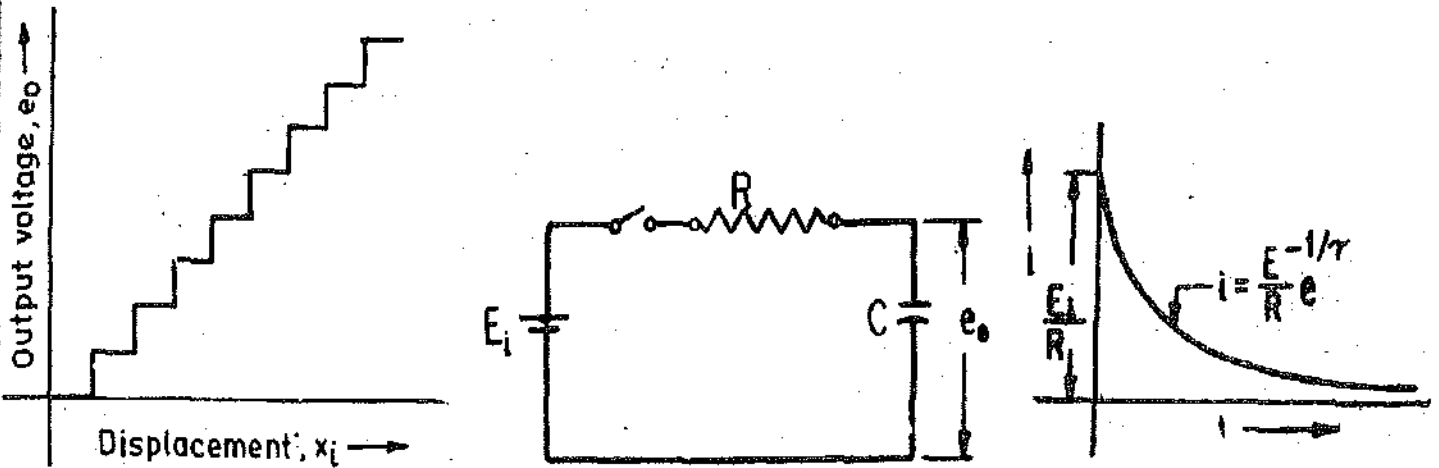

Fig. 24.8. Actual relationship between input (displacement), and output (voltage) of a linear potentiometer.

(a) (b)
Fig. 24.9. R-C circuit and its response to step input.

Let the current in the circuit be $i(t)$ at any instant $t=t$. All initial conditions are assumed to be zero.

$$E_i u(t) = Ri(t) + \frac{1}{C} \int idt$$

Taking the Laplace transform, we have : $\frac{E_i}{s} = RI(s) + \frac{1}{Cs} I(s) = \left(R + \frac{1}{Cs} \right) I(s)$

$$\text{or } E_i = \frac{1 + RCs}{C} I(s)$$

$$\therefore I(s) = \frac{CE_i}{1 + RCs} = \frac{E_i}{R} \left(\frac{RC}{1 + RCs} \right) = \frac{E_i}{R} \left(\frac{1}{s + 1/RC} \right)$$

Taking the inverse Laplace transform,

$$i(t) = \frac{E_i}{R} e^{-t/RC} = \frac{E_i}{R} e^{-t/\tau} \quad \dots(24.32)$$

where

$$\tau = \text{time constant of the circuit} = RC \quad \dots(24.33)$$

The plot of current i versus time t is shown in Fig. 24.9 (b). The current decays exponentially with time. The initial current is E_i/R while the final current is zero which occurs only at $t = \infty$.

$$\text{Output voltage across the capacitor } e_o(t) = \frac{1}{C} \int idt$$

Differentiating the above equation, we have :

$$\frac{d[e_o(t)]}{dt} = \frac{1}{C} i = \frac{E_i}{RC} e^{-t/RC}$$

Taking Laplace transform of above, we get :

$$s E_0(s) = \frac{E_i}{(1+sRC)}$$

or
$$E_0(s) = \frac{E_i}{s(1+sRC)} = \frac{E_i}{s(1+s\tau)}$$

By factorizing, we get :
$$E_0(s) = E_i \left[\frac{1}{s} - \frac{\tau}{1+s\tau} \right]$$

Taking Inverse Laplace transform we get :

$$e_0(t) = E_i \left[1 - e^{-t/\tau} \right]$$

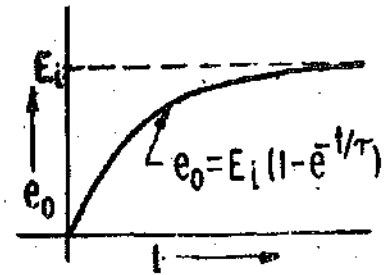

...(24.34) Fig. 24.10. Variation of voltage across capacitor with time.

The variation of voltage across the capacitor with time is shown in Fig. 24.10.

24.16. Thermal System. The thermal system is described by a first order differential equation. When subjected to a step input this equation can be written as :

$$RC \frac{d\theta}{dt} + \theta(t) = h_i u(t) R \quad (\text{See Eqn. 24.22})$$

or
$$\tau \frac{d\theta(t)}{dt} + \theta(t) = h_i u(t) R$$

where $\tau = RC = \text{thermal time constant, s.}$

Taking the Laplace transform, we have : $(\tau s + 1)\theta(s) = \frac{RH_i(s)}{s}$

\therefore Transfer function $G(s) = \frac{\theta(s)}{H_i(s)} = \frac{R}{s(1+\tau s)}$... (24.35)

and Dimensionless transfer function $\frac{G(s)}{R} = \frac{\theta(s)}{RH_i(s)} = \frac{1}{s(1+\tau s)}$... (24.36)

$\therefore \theta = \theta_0 \left(1 - e^{-t/\tau} \right)$... (24.37)

where $\theta_0 = \text{final steady output temperature} = R h_i$... (24.38)

Eqn. 24.36 indicates that temperature rises exponentially with time when heat rate is increased suddenly.

24.17. General First Order Differential Equation. If in Eqn. 24.23 all a' 's and b' 's other than a_1 , a_0 and b_0 are taken as zero, we get :

$$a_1 \frac{dc(t)}{dt} + a_0 c(t) = b_0 r(t) \quad \dots (24.39)$$

Any instrument that follows this equation is by definition a first order instrument. Eqn. 24.39 has three constants viz : a_0 , a_1 , and b_0 but only two are needed. The entire equation is divided by a_0 giving :

$$\frac{a_1}{a_0} \frac{dc(t)}{dt} + c(t) = \frac{b_0}{a_0} r(t)$$

or
$$\tau \frac{dc(t)}{dt} + c(t) = S r(t) \quad \dots (24.40)$$

where $S = \frac{b_0}{a_0} = \text{static sensitivity}$ and $\tau = \frac{a_1}{a_0} = \text{time constant}$

The time constant τ has always the dimensions of time. The static sensitivity has the dimensions of output/input.

Taking Laplace transform of Eqn. 24.40, we get :

$$\tau s C(s) + C(s) = SR(s) \text{ or } C(s)[1 + \tau s] = SR(s)$$

$$\therefore \text{Transfer function of a first order system is : } G(s) = \frac{C(s)}{R(s)} = \frac{S}{(1 + \tau s)} \quad \dots(24.41)$$

and the dimensionless transfer function $\frac{G(s)}{S} = \frac{1}{(1 + \tau s)}$... (24.42)

24.18. Response of a first order system to a unit step input. Let a unit step input $u(t)$ be applied to a first order system.

$$\therefore r(t) = u(t) \text{ and } R(s) = 1/s$$

The transfer of a first order system is $G(s) = \frac{1}{1 + \tau s}$

$$\therefore \text{Output } C(s) = G(s) R(s) = \frac{1}{s(1 + \tau s)} = \frac{1}{s} - \frac{\tau}{1 + \tau s}$$

Taking Inverse Laplace transform

Output $c(t) = 1 - e^{-t/\tau}$... (24.43)

This is plotted in Fig. 24.11. It is seen that the output rises exponentially from zero value to the final value of unity. The initial slope of the curve is given by :

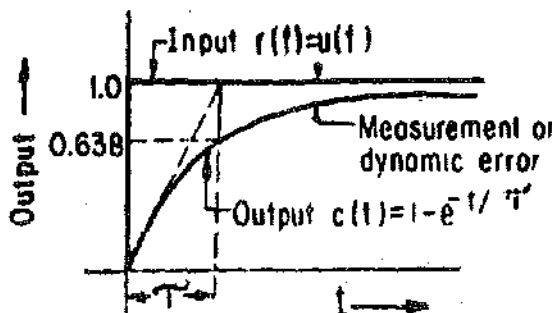

Fig. 24.11. Response of a first order system to a step input.

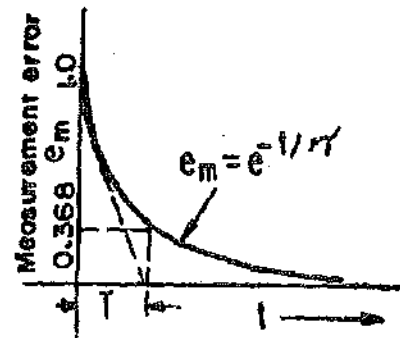

Fig. 24.12. Measurement (Dynamic) error for a first order system when subjected to a step input.

$$\left. \frac{dc}{dt} \right|_{t=0} = \frac{1}{\tau} e^{-t/\tau} \Big|_{t=0} = \frac{1}{\tau} \quad \dots(24.44)$$

Thus if the initial rate of change is maintained, the system will reach its final value in time τ , the time constant.

$$c(t) = 1 - e^{-t/\tau} = 0.632$$

Thus for a rising exponential function the time constant τ is defined as the time to reach 63.2% of its final value. For a decaying function the time constant is defined as the time taken to fall to 36.8 of its initial value. It is obvious that all first order systems will settle to their final value at $t = \infty$. Therefore we must define some other yardstick to distinguish the response of one system from another.

The measurement of Dynamic error is defined as $e_m(t) = r(t) - c(t)$... (24.45)

$$= 1 - [1 - e^{-t/\tau}] = e^{-t/\tau} \quad \dots(24.46)$$

This is plotted in Fig. 24.13.

$$\therefore \text{Steady state error } e_{ss} = \lim_{t \rightarrow \infty} e_m(t) = e^{-t/\tau} = 0 \quad \dots(24.47)$$

Thus the first order system tracks the unit step input with zero static error.

A dynamic characteristic useful in characterising the speed of response of any instrument is the settling time. This is the time (after the application of a step input) for the instrument to reach and stay, within a plus and minus tolerance band around its steady state value. A small settling time is thus indicative of fast response. It is obvious that the numerical value of the settling band depends on tolerance band used and this band must always be specified.

The values of per unit output and measurement error at various intervals of time for a step input are given in Table 24.3.

TABLE 24.3
Per unit output and measurement error for a step input

t/τ	Per unit output	Per unit measurement error
0	0	1.000
1	0.632	0.368
2	0.865	0.135
3	0.950	0.050
4	0.982	0.018
5	0.993	0.007
∞	1.000	0

Thus if one speaks of 5% settling time, it means that the system has reached its specified value after a time which is thrice the time constant. (See Table 24.3 and Fig. 24.13).

It is often assumed that the instrument or system has reached its final steady or maximum value after an interval of 5τ .

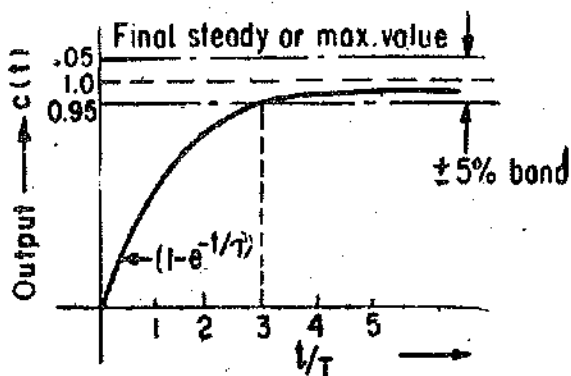

Fig. 24.13. Response of first order system to step input. The settling time is 3τ for $\pm 5\%$ band.

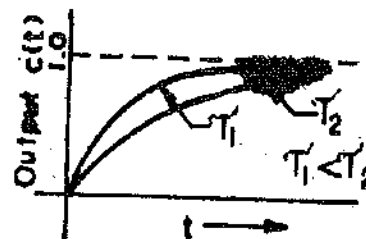

Fig. 24.14. Response of first order systems for a step input for different time constants.

The time constant is indicative of how fast the system tends to reach the final value. A large time constant corresponds to a slow system response and a small time constant represents a fast system.

response as shown in Fig. 24.14. It shows two curves with time constants τ_1 and τ_2 . System with time constant τ_1 is faster than the system with time constant τ_2 .

In some cases the initial conditions are not zero. Let us consider the case of thermometer subjected to a step input.

Let θ_{in} = initial temperature ; °C, θ_0 = final steady temperature ; °C,
and τ = time constant ; s

The temperature at any instant t is given by :

$$\theta = \theta_0 \left[1 - e^{-t/\tau} \right] + \theta_{in} e^{-t/\tau} = \theta_0 + (\theta_{in} - \theta_0) e^{-t/\tau} \quad \dots(24.48)$$

Example 24.1. A thermometer has a time constant of 3.5 s. It is quickly taken from a temperature 0°C to water bath at 100°C. What temperature will be indicated after 1.5 s ?

Solution. From above it is clear that the thermometer is subjected to a step input of 100°C.

From Eqn. 24.37, the output temperature after 1.5 s is given as :

$$\theta = \theta_0 \left(1 - e^{-t/\tau} \right) = 100 \left(1 - e^{-1.5/3.5} \right) = 34.85^\circ\text{C}.$$

Example 24.2. A temperature-sensitive transducer is subjected to a sudden temperature change. It takes 10 s for the transducer to reach equilibrium condition (five time constants). How long will it take for the transducer to read half of the temperature difference.

Solution. Time to reach equilibrium conditions = $5\tau = 10$ s.

\therefore Time constant $\tau = 10/5 = 2$ s.

Now
$$\theta = \theta_0 \left(1 - e^{-t/\tau} \right) \quad \text{or} \quad \frac{\theta}{\theta_0} = 1 - e^{-t/\tau}$$

The time to read half of the temperature difference can be calculated as under

$$\frac{\theta}{\theta_0} = \frac{1}{2} = 1 - e^{-t/2} \quad \text{or} \quad e^{-t/2} = 0.5$$

\therefore Time to read half of the temperature difference $t = 1.38$ s.

Example 24.3. A temperature sensing device can be modelled as a first order system with a time constant of 6 s. It is suddenly subjected to a step input of 25°C–150°C. What temperature will be indicated in 10 s after the process has started ?

Solution. It is given that :

final steady state temperature $\theta_0 = 150^\circ\text{C}$,

initial steady temperature $\theta_{in} = 25^\circ\text{C}$, and, time constant $\tau = 6$

Therefore, the temperature after 10 s can be calculated using Eqn. 24.48.

$$\theta = \theta_0 + (\theta_{in} - \theta_0) e^{-t/\tau} = 150 + (25 - 150) e^{-10/6} = 126.4^\circ\text{C}.$$

Example 24.4 Assume the same conditions as given in the above example except that a step input of 150°C–25°C is applied. Find the indicated temperature after 10 s.

Solution. In this case :

Final steady state temperature $\theta_0 = 25^\circ\text{C}$, and initial temperature $\theta_i = 150^\circ\text{C}$.

\therefore Temperature rise after 10 s is given by :

$$\theta = 25 + (150 - 25) e^{-10/6} = 48.6^\circ\text{C}.$$

24.19. Ramp Response of a First Order System

The applied input is a unit ramp defined as :

$$r(t) = t \quad \therefore R(s) = 1/s^2$$

The transfer function of a first order system is :

$$G(s) = \frac{1}{1 + \tau s}$$

$$\therefore \text{output } C(s) = G(s) R(s) = \frac{1}{s^2(1 + \tau s)} = \frac{1}{s^2} - \frac{\tau}{s} + \frac{\tau^2}{1 + s}$$

$$\text{Taking the Inverse Laplace transform, } c(t) = t - \tau \left(1 - e^{-t/\tau} \right) \quad \dots(24.49)$$

The dynamic response of a first order system to a ramp input is shown in Fig. 24.15.

The measurement error or dynamic error is :

$$e_m(t) = r(t) - c(t) = \tau \left(1 - e^{-t/\tau} \right) \quad \dots(24.50)$$

$$\therefore \text{Final steady state error, } e_{ss} = \lim_{t \rightarrow \infty} e_m(t) = \tau \quad \dots(24.51)$$

Thus the first order system will track the unit ramp input with a steady state error τ which is equal to the time constant of the system.

If the system is subjected to a ramp input $r(t) = At$.

$$\text{Then the output is : } c(t) = A \left[t - \tau \left(1 - e^{-t/\tau} \right) \right] \quad \dots(24.52)$$

$$\text{and the measurement of dynamic error } e_m(t) = r(t) - c(t) = A\tau e^{-t/\tau} \quad \dots(24.53)$$

Example 24.5. The temperature of a furnace is increasing at a rate 0.1°C/s . What is the maximum permissible time constant of a first order instrument that can be used, so the temperature is read with a maximum error of 5°C .

Solution.

A ramp signal of 0.1°C/s is applied to the instrument. $\therefore A = 0.1$

Maximum steady state error for a ramp signal applied to a first order instrument is $e_{ss} = A\tau$ (See Eqn. 24.51).

$$\therefore \text{Maximum allowable time constant } \tau = \frac{e_{ss}}{A} = \frac{5}{0.1} = 50 \text{ s.}$$

Example 24.6. A balloon, carrying a first order thermometer with a 15 s time constant, rises through atmosphere at a speed of 6 m/s. Assume temperature varies with altitude at a rate of 0.005°C/m . The balloon gives information about temperature and altitude through radio signals. At an altitude of 300 m, the balloon radios a temperature 15°C . What is the true altitude at which 15°C occurs.

Solution. Rate of change of temperature with time $= 0.005 \times 6 = 0.03^\circ\text{C/s}$.

Now the ramp signal of 0.03°C/s is applied to the first order thermometer.

From Eqn. 24.51, the steady state error $e_{ss} = A\tau = 0.03 \times 15 = 0.45^\circ\text{C}$.

$$\text{Error in altitude} = \frac{0.45}{0.03} \times 6 = 90 \text{ m.}$$

Therefore the actual altitude when a temperature of 30°C had occurred $= 3000 - 90 = 2910 \text{ m.}$

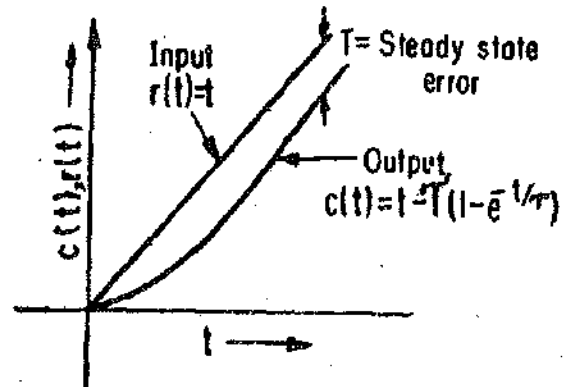

Fig. 24.15. Ramp response of a first order system.

24'20. Impulse Response of a First Order System

Let the system be subjected to an impulse of strength A as shown in Fig. 24'16. An impulse of strength A is defined as the in pulse whose area is A times the area of unit impulse function.

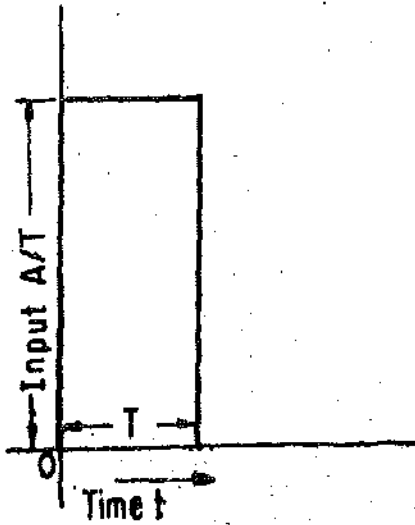

Fig. 24'16. Impulse function of strength A .
Input $r(t) = A \delta(t)$ and $R(s) = A$

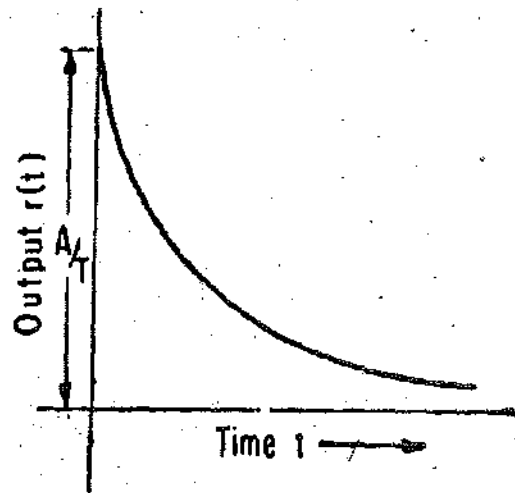

Fig. 24'17. Impulse response of a first order system.

$$\therefore C(s) = \frac{A}{1 + \tau s} \quad \text{or output } c(t) = \frac{Ae^{-t/\tau}}{\tau} \quad \dots(24'54)$$

Fig. 24'17 shows the impulse response of a first order system.

The above equation is valid if the input has the same units as the output. But if the units are

different, the output is given by :

$$c(t) = \frac{SA}{\tau} e^{-t/\tau} \quad \dots(24'55)$$

24'21. Time Response of a Second Order System

A second order system is defined by the following equation :

$$a_2 \frac{d^2 c(t)}{dt^2} + a_1 \frac{d c(t)}{dt} + a_0 c(t) = b_0 r(t) \quad \dots(24'56)$$

Let us consider a typical second order system. This system is the mass-damper system shown in Fig. 24'2. We have :

$$M \ddot{x}(t) + D \dot{x}(t) + Kx(t) = f(t).$$

Taking the Laplace transform we get :

$$Ms^2 X(s) + sD X(s) + KX(s) = F(s)$$

\therefore The transfer function is :

$$\frac{F(s)}{X(s)} = \frac{1}{Ms^2 + Ds + K} = \frac{1/M}{s^2 + Ds/M + K/M}$$

The normalized (dimensionless) transfer function is

$$G(s) = \frac{F(s)}{KX(s)} = \frac{K/M}{s^2 + Ds/M + K/M} = \frac{\omega_n^2}{s^2 + 2\zeta\omega_n s + \omega_n^2} \quad \dots(24'57)$$

where ω_n = natural frequency ; rad/s, and ζ = damping ratio = $\frac{D}{2\sqrt{KM}}$... (24'58)

The transfer function of all second order systems are described by Eqn. 24'58. Comparing the equations given above :

Now we can define the static sensitivity as :

$$S = \frac{b_0}{a_0} \quad \dots(24'59)$$

Natural frequency $\omega_n = \sqrt{K/M} = \sqrt{a_0/a_2}$ rad/s. ... (24'60)

and Damping ratio $\zeta = \frac{D}{2\sqrt{KM}} = \frac{a_1}{2\sqrt{a_0a_2}}$... (24'61)

For a mechanical rotational system the natural frequency $\omega_n = \sqrt{K/J}$ rad/s ... (24'62)

and Damping ratio $\zeta = \frac{D}{2\sqrt{KJ}}$... (24'63)

As described above, the non-dimensionalized transfer function of a second order system is described as :

$$G(s) = \frac{\omega_n^2}{s^2 + 2\zeta\omega_n s + \omega_n^2}$$

The roots of equation $s^2 + 2\zeta\omega_n s + \omega_n^2 = 0$ determine the response of the system.

The roots are :

$$s_1, s_2 = -\zeta\omega_n \pm \sqrt{\zeta^2\omega_n^2 - \omega_n^2} = -\zeta\omega_n \pm \omega_n\sqrt{\zeta^2 - 1} \quad \dots(24'64)$$

There are three cases :

(i) **Overdamped System** : In this case $\zeta > 1$.

The two roots are real and unequal.

The response of an overdamped second order system to a unit step input given by :

$$c(t) = 1 - \frac{\zeta + \sqrt{\zeta^2 - 1}}{2\sqrt{\zeta^2 - 1}} e^{(-\zeta + \sqrt{\zeta^2 - 1})\omega_n t} + \frac{\zeta - \sqrt{\zeta^2 - 1}}{2\sqrt{\zeta^2 - 1}} e^{(-\zeta - \sqrt{\zeta^2 - 1})\omega_n t} \quad \dots(24'65)$$

(ii) **Critically Damped System** : In this system $\zeta = 1$.

∴ Thus the roots are equal and real, or $s_1, s_2 = -\omega_n$.

The equation for response to a unit step input, in this case, is given by :

$$c(t) = 1 - (1 + \omega_n t) e^{-\omega_n t} \quad \dots(24'66)$$

(iii) **Underdamped System** : In this case $\zeta < 1$ and therefore we get a complex conjugate pair of roots. The roots are given by :

$$s_1, s_2 = -\zeta\omega_n \pm j\omega_n\sqrt{1 - \zeta^2} = -\zeta\omega_n \pm j\omega_d \quad \dots(24'67)$$

ω_d is called the damped natural frequency. It is given by :

$$\omega_d = \omega_n\sqrt{1 - \zeta^2} \quad \dots(24'68)$$

*The measurement systems are underdamped in almost all the applications. Therefore study of response of second order systems, where the roots are a complex conjugate pair, is very important.

* See the analysis of response of a galvanometer in Art. 7'7 page 143 onwards.

The response of an underdamped second order system to a unit step input is given by

$$= 1 - \frac{e^{-\zeta\omega_n t}}{\sqrt{1-\zeta^2}} \sin [\omega_n \sqrt{1-\zeta^2} t + \phi] \quad \dots(24.69)$$

$$= 1 - \frac{e^{-\zeta\omega_n t}}{\sqrt{1-\zeta^2}} \sin [\omega_d t + \phi] \quad \dots(24.70)$$

where $\phi = \cos^{-1} \zeta = \tan^{-1} \frac{\sqrt{1-\zeta^2}}{\zeta} \quad \dots(24.71)$

Measurement error = $e_m(t) = r(t) - c(t) = \frac{e^{-\zeta\omega_n t}}{\sqrt{1-\zeta^2}} \sin [\omega_n \sqrt{1-\zeta^2} t + \phi] \quad \dots(24.72)$

Steady state error $e_{ss} = \lim_{t \rightarrow \infty} e_m(t) = 0 \quad \dots(24.73)$

Thus the steady state error of a second order system to a step input is zero.

The final steady state output $e_{ss} = \lim_{t \rightarrow \infty} c(t) = 1 \quad \dots(24.74)$

Thus a second order system tracks its input without any error.

The response of an underdamped ($\zeta < 1$) second order system is shown in Fig. 24.18. It is a sinusoid with a decaying amplitude.

24.2.2. Time Domain Specifications

When an underdamped system is used there are a few properties of interest. These properties put in qualitative form are :

- (i) how fast the system moves to follow the applied input ?
- (ii) how oscillatory is the system ?
- (iii) how long will it take the system to practically reach its final steady state value ?

The time domain specifications cover the above properties in a quantitative form. The terms are explained in context with response to a step input.

1. Rise Time t_r . It is defined as time required for the system to rise from 0 to 100 per cent of its final value (See Fig. 24.18).

$$\text{Rise time } t_r = \frac{\pi - \cos^{-1} \zeta}{\omega_n \sqrt{1-\zeta^2}} \quad \dots(24.75)$$

2. Peak Time t_p . It is the time required for the output to reach the peak of time response or peak overshoot.

Time to reach the first peak (overshoot) is

$$t_p = \frac{\pi}{\omega_n \sqrt{1-\zeta^2}} \quad \dots(24.76)$$

3. Peak overshoots M_p . The per unit peak overshoot is defined as :

$$M_p = \frac{c(t_p) - c(\infty)}{c(\infty)} \quad \dots(24.77)$$

For a unit step input $c(\infty) = c_{ss} = 1$

$$\therefore M_p = c(t_p) - 1 = e^{-\pi\zeta/\sqrt{1-\zeta^2}} \quad \dots(24.78)$$

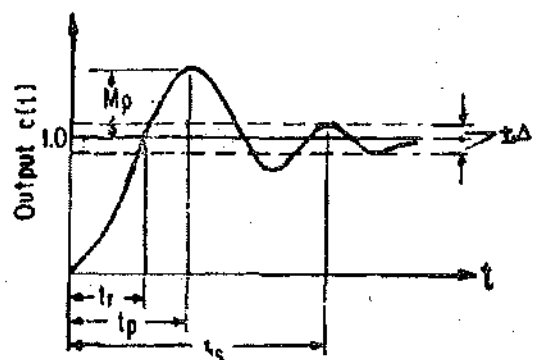

Fig. 24.18. Step response of second order system to a unit step input.

4. **Setting Time t_s .** It is the time required for the output to reach and stay within a specified tolerance band $\pm \Delta$. This tolerance band is either 2% or 5% of the final steady state value. The settling time can be found by equating the exponentially term equal to the tolerance band.

Thus for 2% tolerance band: $\frac{e^{-\zeta\omega_n t_s}}{\sqrt{(1-\zeta^2)}} = 0.02$

An approximate solution of this equation is :

Settling time $t_s = \frac{4}{\zeta\omega_n} = 4T$... (24.79)

where T is the time constant of the exponential term.

Form a 5% band, the settling time $t_s = \frac{3}{\zeta\omega_n} = 3T$... (24.80)

where $T = 2D/J$... (24.81)

24.23. **Ramp Response of a Second Order System**

Let us consider a unit ramp input is applied to an under damped second order system. Thus :

$r(t) = t$ and $R(s) = \frac{1}{s^2}$

\therefore Output $C(s) = \frac{1}{s^2} \left[\frac{\omega_n^2}{s^2 + 2\zeta\omega_n s + \omega_n^2} \right]$

Taking Inverse Laplace transform,

$c(t) = t - \frac{2\zeta}{\omega_n} + \frac{e^{-\zeta\omega_n t}}{\omega_n \sqrt{(1-\zeta^2)}} \sin [\omega_n \sqrt{(1-\zeta^2)}t + \cos^{-1}\zeta]$... (24.82)

The response of the system with various values of ζ is shown in Fig. 24.19.

This measurement error due to a ramp input is :

$e_m(t) = r(t) - c(t) = \frac{2\zeta}{\omega_n} - \frac{e^{-\zeta\omega_n t}}{\omega_n \sqrt{(1-\zeta^2)}} \sin [\omega_n \sqrt{(1-\zeta^2)}t + \cos^{-1}\zeta]$... (24.83)

\therefore Steady state error

$e_{ss} = e_m(t) = \frac{2\zeta}{\omega_n}$... (24.84)

Time constant $\tau = \frac{1}{\omega_n}$... (24.85)

The time lag

$T_1 = \frac{2\zeta}{\omega_n} = 2\zeta\tau$... (24.86)

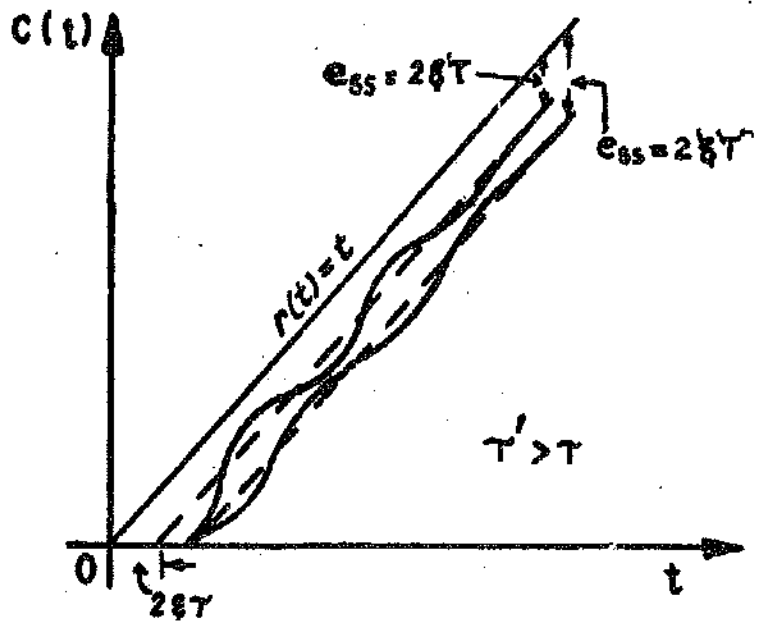

Fig. 24.19. Unit-ramp response of second-order system.

Example 24.7. The moving system of an instrument has a mass of 5 gm and a spring stiffness of 2×10^3 N/rad. Calculate (i) natural frequency, and (ii) the damping-constant necessary to prevent oscillations. Suppose if the damping ratio is reduced to 60% of its value as in part (ii) what is the frequency of damped-oscillations ?

Solution (i) Mass $M = 5 \text{ gm} = 0.005 \text{ kg}$. Spring constant $K = 2 \times 10^3 \text{ N/rad}$.

$$\therefore \text{Natural frequency of oscillations } \omega_n = \sqrt{\frac{K}{M}} = \sqrt{\frac{2 \times 10^3}{0.005}} = 632.4 \text{ rad/s.}$$

(ii) In order that the oscillations be just prevented, the instrument must be critically damped. Therefore, $\zeta = 1$.

$$\text{From Eqn. 24.61, damped constant } D = 2\sqrt{KM} = 2\sqrt{2 \times 10^3 \times 0.005} = 6.32 \text{ N/ms}^{-1}.$$

If the damping ratio is reduced to 60% of its value $\zeta = 0.6$.

$$\therefore \text{Damped frequency, } \omega_d = \omega_n \sqrt{1 - \zeta^2} = 632.4 \times \sqrt{1 - 0.6^2} = 506 \text{ rad/s.}$$

Example 24.8. A d'Arsonval galvanometer is a second order system. It has a spring stiffness such that a torque of $40 \mu\text{N m}$ gives a steady deflection of 90° . If the inertia of the rotating parts is $0.5 \times 10^{-6} \text{ kg-m}^2$ and the damping co-efficient is $5 \mu\text{N m/rad s}^{-1}$, determine the damping ratio, the natural angular frequency, the damped angular frequency, and the time constant of the movement.

Determine the steady state dynamic error when the input voltage is increasing at a steady rate of 5 V/s .

$$\text{Solution. The stiffness constant } K = \frac{40 \times 10^{-6}}{\pi/2} = 25.46 \mu\text{N/rad.}$$

From Eqn. 24.63 the damping ratio :

$$\zeta = \frac{D}{2\sqrt{KJ}} = \frac{5 \times 10^{-6}}{2\sqrt{25.46 \times 10^{-6} \times 0.5 \times 10^{-6}}} = 0.7.$$

$$\text{Natural angular frequency } \omega_n = \sqrt{K/J} = \sqrt{\frac{25.46 \times 10^{-6}}{0.5 \times 10^{-6}}} = 7.13 \text{ rad/s.}$$

$$\text{Damped frequency } \omega_d = \omega_n \sqrt{1 - \zeta^2} = 7.13 \times 7.13 \sqrt{1 - (0.7)^2} = 5.1 \text{ rad/s.}$$

$$\text{Time constant } \tau = \frac{1}{\omega_n} = \frac{1}{7.13} = 0.14 \text{ s.}$$

$$\text{For a unit ramp input the steady state error is : } e_{ss} = \frac{2\zeta}{\omega_n} \quad (\text{See Eqn. 24.84})$$

$$\text{For a ramp input of } 5 \text{ V/s, the steady state error } e_{ss} = 5 \times 2 \times \frac{\zeta}{\omega_n} = 5 \times 2 \times \frac{0.7}{7.13} = 0.98 \text{ V}$$

$$\text{Time lag } T_l = 2\zeta\tau = 2 \times 0.7 \times 0.14 \approx 0.2 \text{ s.}$$

Example 24.9. A potentiometer whose moving parts weigh 5 gm measures displacement of a spring mass system as shown in Fig. 24.20. The system is subjected to a step input. The measured natural frequency is 30 Hz . If the spring constant K and mass M of the system are unknown, can the true natural frequency be found from the above data? Suppose an additional 5 gm weight is attached to the potentiometer and the test is repeated. This gives a natural frequency of 25 Hz . Calculate the true natural frequency of the system.

Solution. Mass of the potentiometer, $M_p = 5 \text{ gm} = 0.005 \text{ kg}$.

Before the additional mass is attached, the natural frequency is given by :

$$f_n = \frac{\omega_n}{2\pi} = \frac{1}{2\pi} \sqrt{\frac{K}{(M+M_p)}} \quad \text{or} \quad 30 = \frac{1}{2\pi} \sqrt{\frac{K}{(9+0.005)}} \quad \dots(i)$$

The above expression involves two unknowns K and M and hence cannot be solved.

$$\text{Actual natural frequency of mass-spring system } f_n = \frac{\omega_n}{2\pi} = \frac{1}{2\pi} \sqrt{\frac{K}{M}}$$

Since both K and M are unknown the natural frequency of the system cannot be obtained from (i).

In the second case, an additional mass of 0.005 kg is attached.

$$\therefore 25 = \frac{1}{2\pi} \sqrt{\frac{K}{(M+0.005+0.005)}} = \frac{1}{2\pi} \sqrt{\frac{K}{M+0.01}} \quad \dots(ii)$$

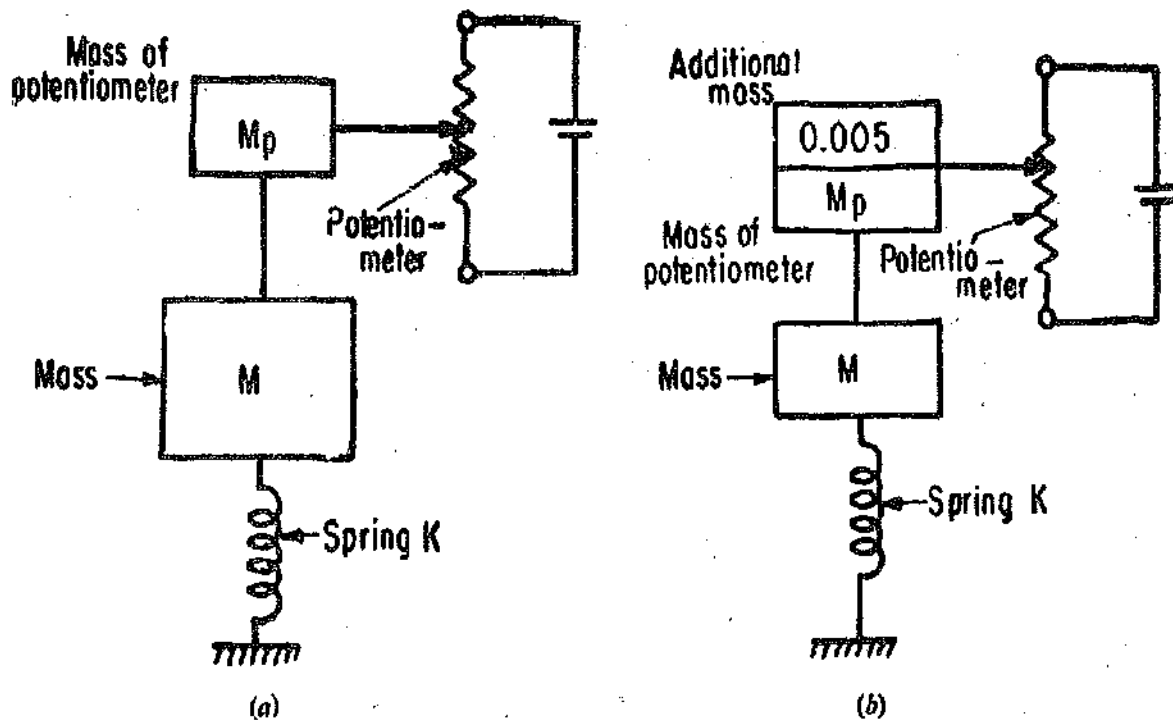

Fig. 24.20. Determination of displacement of mass-spring system with potentiometer.

From (i) and (ii)

$$\therefore M = 6.36 \times 10^{-3} \text{ kg,} \quad \text{and} \quad K = 403.7 \text{ N/m.}$$

$$\text{Hence,} \quad f_n = \frac{1}{2\pi} \sqrt{\frac{K}{M}} = \frac{1}{2\pi} \sqrt{\frac{403.7}{6.36 \times 10^{-3}}} = 40 \text{ Hz.}$$

24.24. Impulse Response of a Second Order System

Let a second order be subjected to impulse of strength A .

The output is given by :

$$c(t) = SA \omega_n \left[\frac{1}{2\sqrt{\zeta^2 - 1}} \left\{ e^{(-\zeta + \sqrt{\zeta^2 - 1})\omega_n t} - e^{(-\zeta - \sqrt{\zeta^2 - 1})\omega_n t} \right\} \right] \quad \dots(24.87)$$

for an overdamped system. For a critically damped system.

$$c(t) = SA \omega_n^2 t e^{-\omega_n t} \quad \dots(24.88)$$

For an underdamped system

$$c(t) = SA \omega_n \left[\frac{1}{\sqrt{1 - \zeta^2}} e^{-\zeta \omega_n t} \sin \sqrt{1 - \zeta^2} \omega_n t \right] \quad \dots(24.89)$$

Fig. 24'21 shows the response a second order system to an impulse input in non-dimensional terms.

FREQUENCY DOMAIN ANALYSIS

24'25. Introduction

We have studied time response of the system with some standard inputs earlier. For studies in frequency domain, the response of the system to a sinusoidal signal is of very great importance. Steady state response to a sinusoidal signal yields a great deal of information about the system since all the standard inputs can be broken into sinusoidal signals with a wide range of frequencies starting from zero onwards.

Input standard signal $r(t) = A_i \sin \omega t \dots(24'90)$

In the frequency domain analysis we are not interested in the transient effects since they die out quickly and under steady state the system output is strictly a sinusoidal in nature having the same frequency as the input. However the amplitude of the output may differ from that of the input and also there may be a phase displacement.

The output may be represented as : $c(t) = A_0 \sin (\omega t + \phi) \dots(24'91)$

where A_0 = amplitude of output and ϕ = phase shift of the output.

The frequency of the input and the output is the same. Therefore the relation between the input and the output can be completely specified by giving their amplitude ratio and the phase shift. The amplitude ratio and the phase shift change with change in the driving frequency ω .

Hence, the frequency response of a system consists of curves of amplitude ratio and phase shift as a function of frequency.

The sinusoidal transfer function is given by Eqn. 24'24

For any given frequency ω , Eqn. 24'24 shows that $C(j\omega)/R(j\omega)$ is a complex number which can always be put in polar form $M \angle \phi$.

where $M = A_0/A_i$ and ϕ = angle of phase shift between A_0 and A_i . ϕ is negative if the output lags the input. This is true only if A_0 and A_i have the same dimensions.

24'26. Frequency Response of a First Order System

Suppose the system is subjected to a sinusoidal input $r(t) = A_i \sin \omega t$.

The dimensionless transfer function of first order system is given by :

$$G(s) = \frac{C(s)}{SR(s)} = \frac{1}{\tau s + 1} \quad (\text{See Eqn. 23'37})$$

The dimensionless sinusoidal transfer function is :

$$G(j\omega) = \frac{C(j\omega)}{SR(j\omega)} = \frac{1}{(j\omega\tau + 1)} \dots(24'92)$$

The dimensionless ratio of output to input is :

$$\therefore M = \left| \frac{A_0}{SA_i} \right| = \left| \frac{1}{(j\omega\tau + 1)} \right| = \frac{1}{\sqrt{1 + \omega^2\tau^2}} \dots(24'93)$$

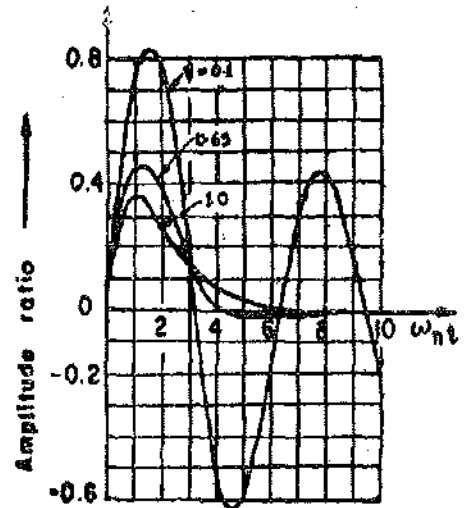

Fig. 24'21. Non-dimensional impulse response of second order system.

∴ Magnitude of output is : $A_0 = \frac{SA_i}{\sqrt{1+\omega^2\tau^2}}$... (24'94)

and phase angle of the output $\phi = -\tan^{-1} \omega\tau$... (24'95)

∴ Output can be written as : $A_0 \sin(\omega t + \phi)$
 $= \frac{SA_i}{\sqrt{1+\omega^2\tau^2}} \sin(\omega t - \tan^{-1} \omega\tau)$... (24'96)

∴ The ratio of input to output $\left| \frac{A_0}{A_i} \right| = \frac{S}{\sqrt{1+\omega^2\tau^2}}$... (24'97)

Thus higher the frequency, higher is the attenuation in output. Also if the time constant of the system is large, the attenuation is greater.

Time lag : $T_l = \frac{1}{\omega} \tan^{-1} \omega\tau$ (24'98)

The normalized curves for amplitude ratio and time lag for first order systems are shown in Fig. 24'22.

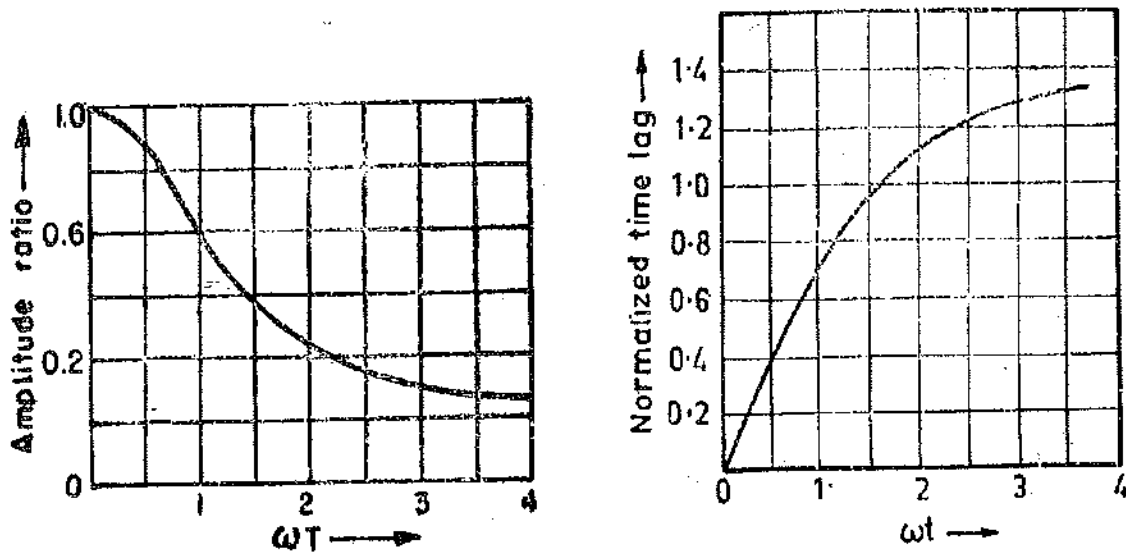

(a) Amplitude ratio (b) Time lag
 Fig. 24'22. Normalized frequency response of a first order systems.

The frequency response of a zero order instrument is given by the following relations

$\left| \frac{A_0}{A_i} \right| = S$... (24'99)

and $\phi = 0$... (24'100)

This is the ideal frequency response.

The first order instrument approaches perfection as Eqns. 24'94 and 24'95 approach Eqns. 24'99 and 24'100. Thus we see that such a situation can be attained if the value of $\omega\tau$ is small. Hence for an instrument with a fixed time constant, there is a particular input frequency ω below

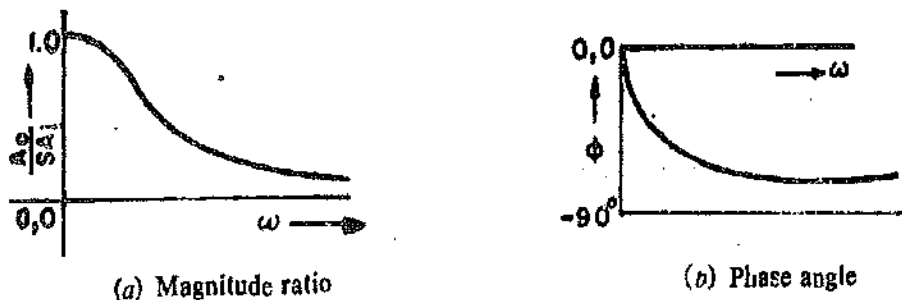

(a) Magnitude ratio (b) Phase angle
 Fig. 24'23. Frequency response of first order systems.

which measurement is accurate. Alternatively if the input of a high frequency is to be measured, the instrument used must have a small time constant. Now we see from Eqns. 24'94 and 24'95 that if $\omega = 0$, $A_0/S A_i = 1$ and $\phi = 0$.

As we go on increasing frequency the magnitude ratio $A_0/S A_i$ goes on decreasing, ϕ goes on increasing till at $\omega = \infty$, $A_0/S A_i = 0$ and $\phi = -90^\circ$. The curves are plotted in Fig. 24'22.

Example 24'10. (a) A thermometer with time constant of 60 s is used for measuring temperature cycling with 600 s time period. Find the lag and ratios of output to input.

(b) If the same instrument is used for measurement of an input with a time period of 120 s. Calculate the measuring lag and the ratio of output to input.

Comment upon the result.

Solution :

(a) Frequency $\omega = 2\pi/60 = 0.01047$ rad/s.

From Eqn. 24'98,

$$\text{Lag } T_l = \frac{1}{\omega} \tan^{-1} \omega\tau = \frac{1}{0.01047} \tan^{-1} (0.01047 \times 60) = 53.5 \text{ s.}$$

$$\text{Ratio of output to input } M = \frac{1}{\sqrt{1 + \omega^2\tau^2}} = \frac{1}{\sqrt{1 + (0.01047 \times 60)^2}} = 0.846.$$

(b) Frequency $\omega = 2\pi/120 = 0.0524$ rad/s.

$$\text{Lag } T_l = \frac{1}{0.0524} \tan^{-1} (0.0524 \times 60) = 24 \text{ s.}$$

$$\text{Ratio of output to input } M = \frac{1}{\sqrt{1 + (0.0524 \times 60)^2}} = 0.303$$

Thus the instrument fidelity decreases rapidly when subjected to rapid fluctuations in input. A thermometer with 60 s time constant shows 84.6% of actual input when subjected to a frequency of 0.01047 rad/s. But if the same instrument is subjected to an input having a frequency which 5 times the earlier, the output drops to 30.3% of the input. Thus the dynamic error is so large the instrument readings become meaningless. It is clear that if an instrument must indicate an output which is within 10% of the true value, then $\omega\tau$ must be below 0.5

Example 24'11. A first order instrument must measure signals with frequency content up to 100 Hz with an amplitude inaccuracy of 5 per cent. What is the maximum allowable time constant? What will be the phase shift at 50 Hz and 100 Hz.

Solution :

Maximum allowable inaccuracy = 5%.

\therefore Minimum allowable inaccuracy of $M = 1 - 0.05 = 0.95$.

Frequency $\omega = 2\pi \times 100 = 628$ rad/s.

The maximum allowable time constant can be calculated by using Eqn. 24'93.

$$M = \frac{1}{\sqrt{1 + \omega^2\tau^2}} \quad \text{or} \quad 0.95 = \frac{1}{\sqrt{1 + (628)^2\tau^2}}$$

\therefore Time constant $\tau = 0.52$ ms.

At 50 Hz phase shift $\phi = -\tan^{-1} \omega\tau = -\tan^{-1} (2\pi \times 50 \times 0.52 \times 10^{-3}) = -9.3^\circ$.

At 100 Hz phase shift $\phi = -\tan^{-1} \omega\tau = -\tan^{-1} (2\pi \times 100 \times 0.52 \times 10^{-3}) = -18^\circ$.

Example 24'12. A liquid thermometer has its glass bulb protected by a well. The system can be represented by a double capacity system with time constants of 40 s for the well and 20 s for the bulb. The thermometer is subjected to a cyclic change of $\pm 10^\circ\text{C}$ which occurs every 120 s. Find the maximum value of the indicated temperature and the delay time.

Solution. For a double capacity system, the amplitude ratio of output to input is :

$$M = \frac{1}{\sqrt{1+(\omega\tau_1)^2}} \times \frac{1}{\sqrt{1+(\omega\tau_2)^2}} \text{ and the angle of lag} = \tan^{-1} \omega\tau_1 + \tan^{-1} \omega\tau_2$$

$$\omega = 2\pi f = \frac{2\pi}{T} = \frac{2\pi}{120} = 0.05236 \text{ rad/s.}$$

$$\begin{aligned} \therefore \text{Amplitude ratio } M &= \frac{1}{\sqrt{1+(0.05236 \times 40)^2}} \times \frac{1}{\sqrt{1+(0.05236 \times 20)^2}} \\ &= \frac{1}{\sqrt{1+(2.09)^2}} \times \frac{1}{\sqrt{1+(1.047)^2}} = 0.297. \end{aligned}$$

Maximum indicated temperature = $0.297 \times (\pm 10^\circ) = \pm 2.97^\circ\text{C}$.

Angle of lag = $\tan^{-1} 2.09 + \tan^{-1} 1.047 = 64.4 + 46.3 = 110.7^\circ = 1.93 \text{ rad.}$

Time lag = $\frac{1.93}{0.05236} = 36.9 \text{ s.}$

Example 24'13. (i) An input of $(1 \sin 2t + 0.3 \sin 20t)$ is applied to a first order instrument having a time constant of 0.2 s. (i) Find the output. (ii) If the same input is applied to an instrument having a time constant of 0.002 s, what will be the output? Comment upon the result.

Solution. (i) The output of the system when the time constant is 0.2 s is given by :

$$\begin{aligned} \frac{1}{\sqrt{1+(2 \times 0.2)^2}} \sin \left(2t - \tan^{-1} \frac{2 \times 0.2 \times 180}{\pi} \right) + \frac{0.3}{\sqrt{1+(20 \times 0.2)^2}} \sin \left(20t - \tan^{-1} 20 \times 0.2 \times \frac{180}{\pi} \right) \\ = 0.91 \sin (2t - 21.8^\circ) + 0.073 \sin (20t - 76^\circ) \end{aligned}$$

(ii) The output of the system when the time constant is 0.002 s is given by :

$$\begin{aligned} \frac{1}{\sqrt{1+(2 \times 0.002)^2}} \sin \left(2t - \tan^{-1} 2 \times 0.002 \times \frac{180}{\pi} \right) \\ + \frac{0.3}{\sqrt{1+(20 \times 0.002)^2}} \sin \left(20t - \tan^{-1} 20 \times 0.002 \times \frac{180}{\pi} \right) \\ = 1 \sin (2t - 0.23^\circ) + 0.3 \sin (20t - 2.3^\circ). \end{aligned}$$

It is clear from the results that the output is attenuated and also the phase shift is large if the time constant of the instrument is large. However, if the time constant of the system is very small as compared with the time period of the input, the instrument reproduces the input faithfully, i.e. without attenuation and an insignificant phase shift.

Example 24'14. A thermocouple system has a time constant of 10 s. The system is used to measure the temperature of a furnace which fluctuates sinusoidally between 640°C and 600°C , with a periodic time of 80 s. Determine the maximum and minimum values of the temperature indicated. Calculate the angle of phase shift and also the time lag.

Solution. The maximum value of temperature is 640°C and the minimum value is 600°C . Therefore the temperature oscillates about a mean value of $(640 - 600)/2 = 620^\circ\text{C}$ with an amplitude of 20°C as shown in Fig. 24'23

The frequency of oscillations,

$$\omega = 2\pi f = \frac{2\pi}{80} = 0.0785 \text{ rad/s.}$$

Amplitude of the output about the mean position is :

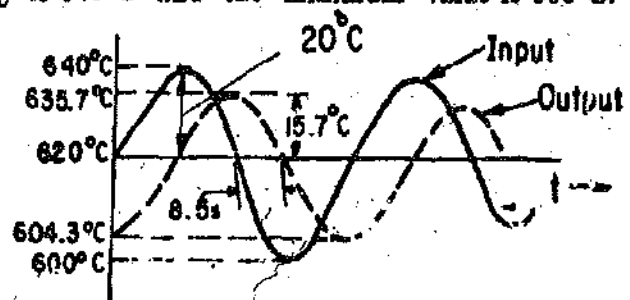

Fig. 24'24

$$A_0 = \frac{A_i}{\sqrt{1 + \omega^2 \tau^2}} = \frac{20}{\sqrt{1 + (0.0785 \times 10)^2}} = 15.7^\circ\text{C}$$

Therefore,

maximum temperature = $620 + 15.7 = 635.7^\circ\text{C}$ and minimum temperature = $620 - 15.7 = 604.3^\circ\text{C}$.

Angle of phase shift $\phi = \tan^{-1}(0.0785 \times 10) = -0.665 \text{ rad} = -38^\circ$.

\therefore Time lag $T_i = \frac{0.665}{0.0785} = 8.5 \text{ s}$.

24.27. Frequency Response of a Second Order System

Let a second order system be subjected to a sinusoidal input $r(t) = A_i \sin \omega t$.

The steady state output is $c(t) = A_0 \sin(\omega t + \phi)$.

The dimensionless transfer function of a second order system is

$$\frac{C(s)}{SR(s)} = \frac{\omega_n^2}{s^2 + 2\zeta\omega_n s + \omega_n^2}$$

The dimensionless sinusoidal transfer function is :

$$\frac{C(j\omega)}{SR(j\omega)} = \frac{\omega_n^2}{(j\omega)^2 + 2\omega_n\zeta(j\omega) + \omega_n^2} = \frac{\omega_n^2}{(\omega_n^2 - \omega^2) + 2j\zeta\omega\omega_n}$$

$$= \frac{1}{(1 - u^2) + 2j\zeta u} \quad \dots(24.101)$$

where $u = \text{normalized frequency} = \omega/\omega_n$... (24.102)

From above it is clear that the ratio of output to input is :

$$M = \left| \frac{C(j\omega)}{SR(j\omega)} \right| = \left| \frac{A_0}{S A_i} \right| = \frac{1}{\sqrt{(1 - u^2)^2 + (2\zeta u)^2}} \quad \dots(24.103)$$

$$= \frac{1}{\sqrt{[1 - (\omega/\omega_n)^2]^2 + [2\zeta\omega/\omega_n]^2}} \quad \dots(24.104)$$

Phase angle $\phi = -\tan^{-1} \left(\frac{2\zeta u}{1 - u^2} \right) = -\tan^{-1} \frac{2\zeta\omega/\omega_n}{[1 - (\omega/\omega_n)^2]} \quad \dots(24.105)$

\therefore Output $A_0 = \frac{S A_i}{\sqrt{(1 - u^2)^2 + (2\zeta u)^2}} \sin [\omega t - \tan^{-1} \frac{2\zeta u}{(1 - u^2)}] \quad \dots(24.106)$

From Eqns. 24.103 and 24.105, find that when :

- $u=0, \quad M=1 \quad \text{and } \phi=0$
- $u=1, \quad M=\frac{1}{2\zeta} \quad \text{and } \phi=-90^\circ$
- $u=\infty, \quad M=0 \quad \text{and } \phi=-180^\circ$

The magnitude ratio and the phase angle characteristics for various values of normalized frequency u for a particular value of ζ are shown in Figs. 24.25 (a) and (b).

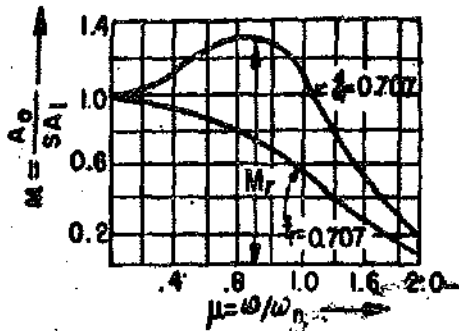

(a) Amplitude ratio

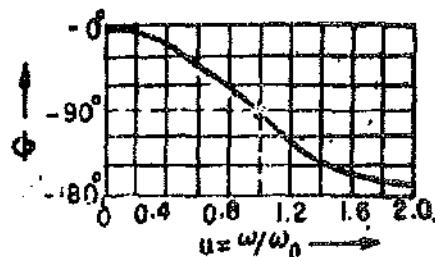

(b) Phase angle

Fig. 24.25. Frequency response of a second order system.

Resonant Frequency. The frequency at which M has the maximum value is known as the resonant frequency. This frequency ω_r , is given by :

$$\omega_r = \omega_n \sqrt{1 - 2\zeta^2} \quad \dots(24'107)$$

Resonant Peak. The maximum value of M occurs at $\omega = \omega_r$. This value is known as resonant peak, M_r . The value of M_r can be found by putting $\omega = \omega_r = \omega_n \sqrt{1 - 2\zeta^2}$ in Eqn. 24'103.

This gives,
$$M_r = \frac{1}{2\zeta \sqrt{1 - \zeta^2}} \quad (24'108)$$

The phase shift at $\omega = \omega_r$ is $\phi_r = -\tan^{-1} \left[\frac{\sqrt{1 - 2\zeta^2}}{\zeta} \right] \quad \dots(24'109)$

It is clear from Eqn. 24'107 that for $\zeta > 1/\sqrt{2}$ i.e. $\zeta > 0.707$, there is no resonant frequency and hence there is no resonant peak.

Bandwidth. If we examine Fig. 24'25, it is found that for frequencies above $\omega > \omega_r$, the amplitude ratio M decreases. The frequency at which M has a value of 0.707 is called the Cut off Frequency ω_c . Above the cut-off frequency ω_c , the value of M decreases below 0.707 $= (1/\sqrt{2})$. This is half power point and therefore the output is greatly attenuated (decreased). The band of frequencies from zero to cut-off frequency ω_c is called the Bandwidth ω_b of the system.

Measurement systems are low pass filters as the value of amplitude ratio is unity at $\omega = 0$. But as the frequency of the input signals increases, the output gets attenuated. Bandwidth is indicative of the satisfactory reproduction of the input signal.

Let $u_b = \frac{\omega_b}{\omega_n} = \text{normalized bandwidth.}$

From Eqn. 24'103, we have :

$$\text{Bandwidth } \omega_b = \omega_n \sqrt{1 - 2\zeta^2 + \sqrt{(2 - 4\zeta^2 + 4\zeta^4)}} \quad \dots(24'110)$$

24.28. Frequency Response Curves.

Fig. 24'26 shows the variation of amplitude ratio and phase shift with change of normalized frequency $u = \omega/\omega_n$ for various values of damping ratio ζ in a second order measurement system. It is clear from the diagram that if a flat frequency response is desired u should be very small or the natural frequency of the system should be very high. (These are the two conditions if the system has to reproduce the high frequency inputs faithfully).

Let us examine the effect of damping ratio, ζ , on the frequency response curves. The damping ratio is a dominating factor in the response of a system and can be varied easily and therefore, it becomes extremely important to study its effect on the system performance. If we critically examine the magnitude ratio and phase shift curves, it is found that the optimum value of ζ lies between 0.6 to 0.7, in case our criteria is the faithful response as far as magnitude is concerned, as with this value we obtain almost a flat curve for the amplitude ratio over a wide range of frequencies. However, if ζ is between 0.6 and 0.7, there is a great

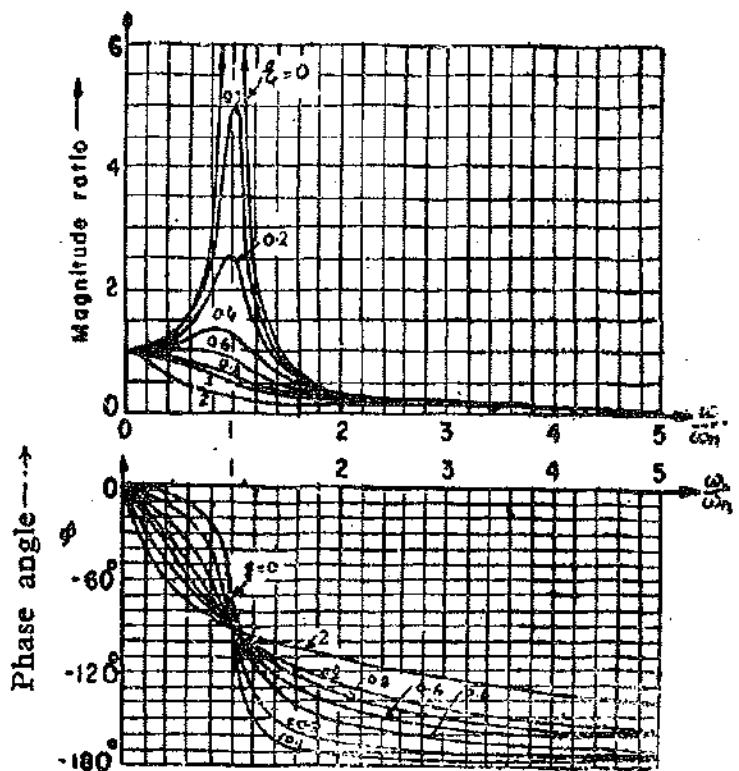

Fig. 24'26. Frequency response curves of second-order system.

phase shift between input and output and hence a great time lag. In situations where it is desired that the magnitude ratio should remain the same and time lag is of no consideration, a damping ratio of 0.6 to 0.7 is recommended for a second order measurement system.

Example 24.15. A torque sensing transducer is connected to the shaft of an electric motor which drives a load which has a moment of inertia of $200 \times 10^{-2} \text{ kg-m}^2$. What should be the damping ratio of the system when a sinusoidal torque varying at a frequency of 2 rad/s is to be reproduced with a maximum error of +10%. The torsional constant is 1.5 N-m/rad.

Solution.

$$\text{Natural frequency } \omega_n = \sqrt{\frac{K}{J}} = \sqrt{\frac{1.5}{200 \times 10^{-2}}} = 2.74 \text{ rad/s.}$$

$$\text{Normalized frequency } u = \frac{\omega}{\omega_n} = \frac{2}{2.74} = 0.73.$$

$$\text{Amplitude ratio } M = \frac{\text{output}}{\text{input}} = \frac{1+0.1}{1} = 1.1.$$

From Eqn. 24.103, the magnitude ratio is :

$$M = \frac{1}{\sqrt{(1-u^2)^2 + (2\zeta u)^2}}$$

$$\text{or } 1.1 = \frac{1}{\sqrt{[1-(0.73)^2]^2 + (2 \times \zeta \times 0.73)^2}} = \frac{1}{\sqrt{0.22 + 2.13\zeta^2}}$$

\therefore Damping ratio $\zeta = 0.68$.

Example 24.16. A diaphragm pressure transducer behaves as a second order system. The static displacement of the diaphragm is proportional to the applied force. If the natural frequency of the diaphragm is 1000 Hz and the damping ratio is 0.6, determine the frequency range over which the amplitude ratio (corresponding to a sinusoidal input) deviates by a maximum amount of 10%.

Solution. The maximum value of M is 1.1 and the minimum is 0.9 as there is 10% deviation of the output from the input.

$$M = \frac{1}{\sqrt{(1-u^2)^2 + (2\zeta u)^2}}$$

The value of frequency can be calculated as under :

$$1.1 = \frac{1}{\sqrt{(1-u^2)^2 + (2 \times 0.6u)^2}} \quad \text{or } u^4 - 0.56u^2 + 0.173 = 0$$

This relationship yields imaginary values of frequencies. Thus with $\zeta = 0.6$, the output is not 1.1 of the input for any frequency. (It is clear that for values of $\zeta < 0.707$, the amplitude ratio cannot be greater than 1).

Let us investigate the attenuation of the input.

$$\text{Now } 0.9 = \frac{1}{\sqrt{(1-u^2)^2 + (2 \times 0.6u)^2}}$$

$$\text{or } u^4 - 0.56u^2 - 0.234 = 0 \quad \text{or } u^2 = 0.84 \quad \text{and } u = 0.916$$

$$\therefore f = u \times f_n = 0.916 \times 1000 = 916 \text{ Hz.}$$

Therefore, the range over which the magnitude ratio remains within 10% of output is : 0-916 Hz.

Example 24.17. A 2nd order instrument has a natural frequency of 4 Hz and the damping ratio is 0.66. If the excitation frequency of the system is 6 Hz, determine the error due to the proximity of excited frequency with the natural frequency of the system.

Solution

$$\text{Ratio of excitation frequency to natural frequency } u = \frac{\omega}{\omega_n} = \frac{6}{4} = 1.5$$

$$\therefore \text{Magnitude ratio, } M = \frac{1}{\sqrt{(1-u^2)^2 + (2\zeta u)^2}} = \frac{1}{\sqrt{[1-(1.5)^2]^2 + (2 \times 0.66 \times 1.5)^2}} = 0.427$$

$$\text{Error} = (-1 + 0.427) \times 100 = -57.3\%$$

UNSOLVED PROBLEMS

1. Find whether the following equations represent linear or non-linear systems. Justify the answers.

- (a) $A = Bx^3 + C$ where A, B and C are constants.
 (b) $y = ax - b$ where a and b are constants.
 (c) $\Delta p = K(\Delta T)$ where K is a constant.

[Ans. (a) Non-linear, (b) Non-linear, (c) Linear]

2. The differential equations describing the time response of systems are given below. Find whether they are time invariant or time variant :

(a) $a_2 \frac{dx^2}{dt^2} + a_1 \frac{dx}{dt} + a_0 x = b_2 \frac{d^2y}{dt^2} + b_1 \frac{dy}{dt} + b_0 y$ (b) $a_1 \frac{dx}{dt} + a_0 x = b_0$

where a_2, a_1, a_0, b_2, b_1 and b_0 are constants.

[Ans. (a) Time Invariant, (b) Time Variant]

3. Fig. 24'27 shows a non-linear system. Prove that the properties of superposition and homogeneity are not satisfied.

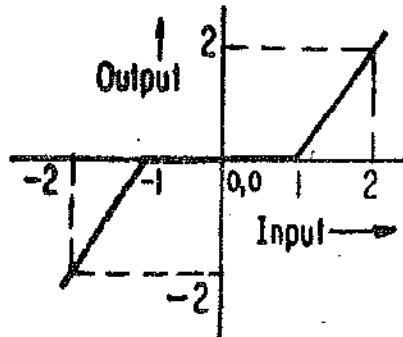

Fig. 24'27

4. A first order system when subjected to a step input has a temperature rise of 25°C after one hour and 37.5°C after two hours starting from cold conditions. Calculate its final steady temperature rise and the thermal time constant. [Ans. 50°C , 1'44 hour]

5. A RC circuit consists of a capacitor of $1 \mu\text{F}$ in series with a resistor of $5 \text{ k}\Omega$. A d.c. voltage of 50 V is suddenly applied across the circuit. Calculate the value of voltage after (a) 5 ms and (b) 25 ms . [Ans. (a) 31.6 V ; (b) 49.6 V]

6. A measuring system has an exponential response to a step input. The time constant of the system is 2 s . What is the time required for reaching (a) 50 per cent and (b) 80 per cent of the final steady state reading? [Ans. (a) 1.39 s , (b) 3.2 s]

7. A thermometer is initially at a temperature of 70°C and is suddenly placed in a liquid which is maintained at 300°C . The thermometer indicates 200°C after a time interval of 3 s . Calculate the time constant for the thermometer. Also calculate the temperature after 5 s . [Ans. 3.6 s , 242.6°C]

8. In a response test on a thermometer, it was put into a temperature-controlled bath of water maintained at 100°C , and the time was observed as the indicated temperature reached the preselected values. The results were as under :

Time (s)	0.0	1.2	3.0	5.6	8.0	11.0	15.0	18.0
Temperature ($^\circ\text{C}$)	20	40	60	80	90	95	98	99

Plot the graph of temperature versus time. Examine the graph, find out the order of the system. Estimate the time constant of the thermometer.

Determine the steady state error when the same thermometer is made to measure the temperature of a liquid which is cooling at a constant rate of 0.2°C/s . [Ans. First order system; 4 s , $+0.8^\circ\text{C}$]

9. A d'Arsonval galvanometer is a second order instrument. In the design of a d'Arsonval galvanometer moving system it is found that the damping ratio is 0.65 and the natural frequency of the undamped oscillations is 4 Hz .

(a) If the sensitivity of the movement is doubled by using springs of smaller stiffness, calculate the new damping ratio and the new natural frequency.

(b) If the damping ratio is now restored to its original value by altering the moment of inertia of the system, determine the final natural frequency of the system. [Ans. (a) 0.92, 2.83 Hz, (b) 2 Hz]

10. A 2 gm mass is suspended from a simple spring. The deflection caused by this mass is 5 mm. What is the natural frequency of the system? [Ans. 0.07 Hz]

11. A production line device is shown in Fig. 24.28. The masses to be weighed have a minimum value of 0.9 kg and a maximum value of 1.1 kg. The weighing platform has a mass of 0.2 gm.

(a) Calculate the value of spring stiffness if the scale deflection is to be within ± 10 mm over the range.

(b) Calculate the value of damping constant provided by the dashpot when a mass of 1 kg is placed on the platform. The damping ratio is 0.7.

(c) Calculate the damping ratio with the minimum and maximum mass on the table.

(d) Determine the percentage overshoot with minimum and maximum mass on the table when they are suddenly placed on it.

[Ans. (a) 0.0981 N/mm; (b) 15.2 N s/m; (c) 0.73, 0.67; (d) 6%, 4%]

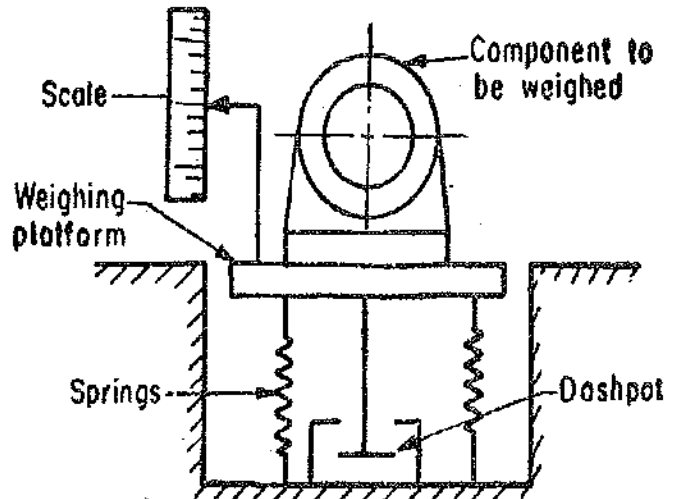

Fig. 24.28

12. A first order thermometer is used to measure the temperature of air cycling at a rate of 1 cycle every five minutes. The time constant of the thermometer is 20 s. Calculate the percentage attenuation indicated by the thermometer.

If the temperature has a sinusoidal variation of $\pm 20^\circ\text{C}$, calculate the indicated variation in temperature.

[Ans. 7.78%, $\pm 18.44^\circ\text{C}$]

13. Determine the ratio of input to output temperature when a first order thermometer is suddenly immersed in a tank of liquid whose temperature varies sinusoidally at a frequency of 1/300 Hz. The thermometer has a time constant of 160 s. Find also the time lag. If the temperature varies between $\pm 20^\circ\text{C}$, what is the indicated value of temperature? [Ans. 0.286, 61 s, $\pm 5.7^\circ\text{C}$]

14. If a cyclic change is taking place every 10 s and the time constant of the system is 10 s, what percentage of cyclic change will be registered assuming the system to be first order one? If the time constant is doubled what would be the amplitude ratio? [Ans. 15.7 per cent; 7.9 per cent]

15. If the temperature of an oven is cycling all a true rate of $\pm 10^\circ\text{C}$ every 40 second, will any thermometer show the $\pm 10^\circ\text{C}$ variation? If the constant of the thermometer is 300 s, what will be the apparent cyclic variation? [Ans. $\pm 0.212^\circ\text{C}$]

16. A pressure measuring gauge is a first order instrument. If the pressure applied were $700 \pm 140 \text{ kN/m}^2$ every 2 second (assuming a sinusoidal variation of pressure with time) find the indicated range of pressure. The time constant of the gauge is 1 s. [Ans. $700 \pm 42.4 \text{ kN/m}^2$]

17. A first order instrument which has a time constant of 0.5 s is subjected to an input of :

$$2 \sin 3t + 0.5 \sin 30t$$

Find the response of the instrument.

[Ans. $1.11 \sin (3t - 56^\circ) + 0.0333 \sin (30t - 86^\circ)$]

18. A pressure is cycling from 50 kN/m^2 to 65 kN/m^2 with a period of 5 s. The attenuation must be limited to 10 per cent what is the maximum time constant permissible in a pressure gauge with a first order response? [Ans. 17.9 s]

19. In a pressure measuring transducer consisting of a number of strain gauges bonded to a diaphragm, the undamped natural frequency of the system is found to be 60 kHz, and the damping ratio 0.6. Calculate the amplitude of the output signal in terms of pressure, if the input pressure to the transducer is fluctuating sinusoidally with an amplitude of 800 kN/m^2 at a frequency of 30 kHz. What is the percentage error in the output amplitude? [Ans. 832 kN/m^2 , +4%]

20. A second order system has a natural frequency of 10 Hz and a damping ratio of 0.3. Calculate the value of resonant frequency and the amplitude ratio at this frequency. Also calculate the band width.

What is the settling time of the system for a $\pm 2\%$ band when subjected to a step input? Find the value of steady state error to unit ramp input. [Ans. 9.05 Hz, 1.75, 14.5 Hz, 1.33 s, 0.06 s]

25.1. Introduction

In a measurement System, the Measurand (quantity under measurement) makes its first contact with system through a Detector. The measurand is converted into an analogous form by the detector. The measurand or the input signal is called Information for the measurement system. The information may be in the form of a physical phenomenon or it may be an electrical signal. The function of the detector is to sense the information and convert it into a convenient form for acceptance by the later stages of the system. The process of detection and conversion of input signal or information from one form to another requires energy. This energy may be extracted from the signal thereby causing loading effects. Thus if energy is extracted from the signal, it will not be faithfully reproduced after conversion which leads to errors. In fact, efforts should be made to supply energy required by the detector from an external source for conversion so that the input signal is converted into a usable output without drawing an undue amount of energy from it. The ideal conversion is when absolutely no energy is extracted from the signal so that it is not distorted and the analogous output of the detector is a faithful representation of the input.

25.2. Primary and Secondary Transducers

The broad definition of a transducer is that it is a device which converts the energy from one form to another. Let us consider the case of a Bourdon gauge for measurement of pressure. This gauge is shown in Fig. 1.4 page 7. The pressure, which is the measurand in this case, makes its contact with the Bourdon tube which acts as the detector. The Bourdon tube simply converts the pressure into a linear mechanical displacement. The linear mechanical displacement is converted into a rotary displacement by the mechanical linkages for deflection of the pointer. Thus Bourdon tube simply performs the function of detection, and nothing else.

Let us take the case of measurement of a compressive force with the help of a load cell in conjunction with strain gauges as shown in Fig. 25.1 (Load cells and strain gauges are explained later in this chapter).

The load cell is a short column or a strut with resistance wire strain gauges bonded to it. The measurand, in this case, is a force and is applied to the column thereby producing strain. The force is first detected by the column and is converted into strain which is a mechanical displacement. The higher the force, the higher is the strain and thus the input signal (force) is converted into an analogous output (strain). This strain changes the resistance of the strain gauges. Thus we have an output which is a change in the value of resistance *i.e.*, electrical in form. Hence, in this case, it takes two processes to convert an input into an analogous output. The first process involves conversion of force into mechanical displacement which is done by the column, while the second process involves conversion of mechanical displacement into change of resistance which is done by strain gauges.

Thus we see that the force is detected by the column in the first stage and hence it is called a Detector or a Primary Transducer. The output signal from the primary transducer is converted subsequently into a usable output by the strain gauges and therefore they are known as Secondary Transducers.

In the case of Bourdon gauge, the Bourdon tube acts as a primary detector-transducer which senses pressure. The output of the Bourdon tube, which is in the form of a displacement, is used

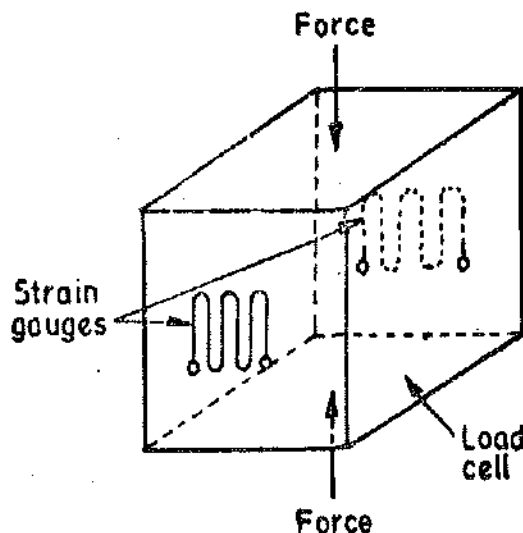

Fig. 25.1. Force measurement with load cell and strain gauges.

directly to drive the mechanical linkages. Thus there is no need to convert the primary signal to a secondary signal.

Consider the case of a Bourdon tube for measurement of pressure as shown in Fig. 25'2. The closed end of the Bourdon tube is connected to the core of an LVDT (Linear Variable Differential Transformer). When there is no pressure applied, the core is at its centre and the voltages induced in the two secondary windings are equal and there is no differential voltage output. But when a pressure is applied to the Bourdon tube, it is converted into a displacement. Due to the mechanical displacement, the core of the LVDT is moved and hence a differential output voltage is obtained. Thus, in this case, two stages of signal conversion are involved. The pressure is first converted into a displacement by the Bourdon tube which acts as **Detector or Primary Transducer**. The mechanical displacement causes the core of the LVDT to move to produce a usable electrical output, voltage in this case, and therefore, the LVDT is called a **Secondary Transducer**.

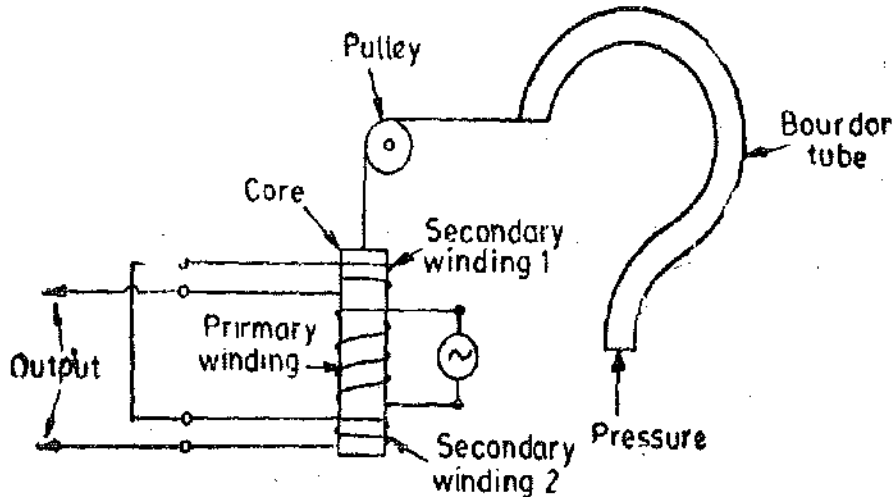

Fig. 25'2. Measurement of Pressure with Bourdon tube and LVDT.

25-3. Classification of Detector-Transducer Stage Devices

The conclusion drawn from the above examples and discussion is that the devices used in the **detector transducer stage**, which forms the first stage of any measurement system, can be classified on the basis of operations performed. The devices may be classified into three categories on this basis:

- Case I: First stage devices used as detectors only.
- Class II: First stage devices used as detector and single transducer.
- Class III: First stage devices used as detector with two transducer stages.

Fig. 25'3 shows a block diagram of a generalized detector transducer stage of a Measurement System.

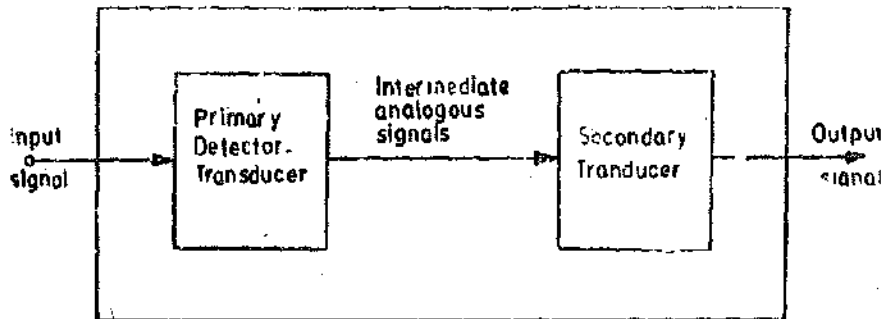

Fig. 25'3. Block diagram of detector-transducer stage.

The primary functions of the detector-transducer stage of a measurement system are :

- (i) sense the measurand properly, and
- (ii) convert the measurand to a format acceptable by the intermediate stage of measurement system (i.e., the signal conditioning stage).

Table 25.1 encompasses the general field of the primary detector-transducer stage in the measurement of physical quantities.

TABLE 25.1
Typical Primary-Transducer Elements

<i>Type</i>	<i>Operation</i>
I. Mechanical	
A. Contacting spindle, pin or finger	Displacement to displacement
B. Elastic Member	
1. Proving ring	Force to displacement.
2. Bourdon tube	Pressure to displacement.
3. Bellows	Pressure to displacement.
4. Diaphragm	Pressure to displacement.
5. Spring	Force to displacement.
C. Mass	
1. Seismic mass	Forcing function to displacement.
2. Pendulum scale	Force to displacement.
3. Manometer	Pressure to displacement.
D. Thermal	
1. Thermocouple	Temperature to electric current.
2. Bimaterial	Temperature to displacement.
3. Temp-stik	Temperature to phase.
E. Hydropneumatic	
1. Static	
(a) Float	Fluid level to displacement.
(b) Hydrometer	Specific gravity to displacement.
2. Dynamic	
(a) Orifice	Velocity to pressure.
(b) Venturi	Velocity to pressure.
(c) Pitot tube	Velocity to pressure.
(d) Vanes	Velocity to force.
(e) Turbines	Linear to angular velocity.
II. Electrical	
A. Resistive	
1. Contacting	Displacement to resistance change.
2. Variable-length conductor	Displacement to resistance change.
3. Variable area conductor	Displacement to resistance change.
4. Variable dimensions of conductor	Strain to resistance change.
5. Variable resistivity of conductor	(i) Air velocity to resistance change.
	(ii) Temperature to resistance change.
B. Inductive	
1. Variable coil dimensions	Displacement to inductance change.
2. Variable air-gap	Displacement to inductance change.
3. Change of core material	Displacement to inductance change.
4. Change of coil positions	Displacement to inductance change.
5. Change of core positions	Displacement to inductance change.
6. Movement of coil	Velocity to inductance change.
7. Movement of permanent magnet	Velocity to inductance change.
8. Movement of core	Velocity to inductance change.
C. Capacitive	
1. Change of air gap	Displacement to capacitance change.
2. Change of plate areas	Displacement to capacitance change.
3. Change of dielectric	Displacement to capacitance change.
D. Electronic	Displacement to current or voltage.
E. Piezoelectric	Displacement to voltage.
F. Photoelectric	Light intensity to voltage.

In most of measurement systems, there is a suitable working combination wherein a Mechanical device acts as a primary detector transducer and the electrical device acts as the secondary transducer with mechanical displacement serving as the intermediate signal.

25.4. Mechanical Devices as Primary Detectors

There is a multiplicity and a variety of physical quantities and most of these quantities are shown in Table 25.1. These physical quantities include force, pressure, displacement, flow rate, temperature and the list is, perhaps, unending.

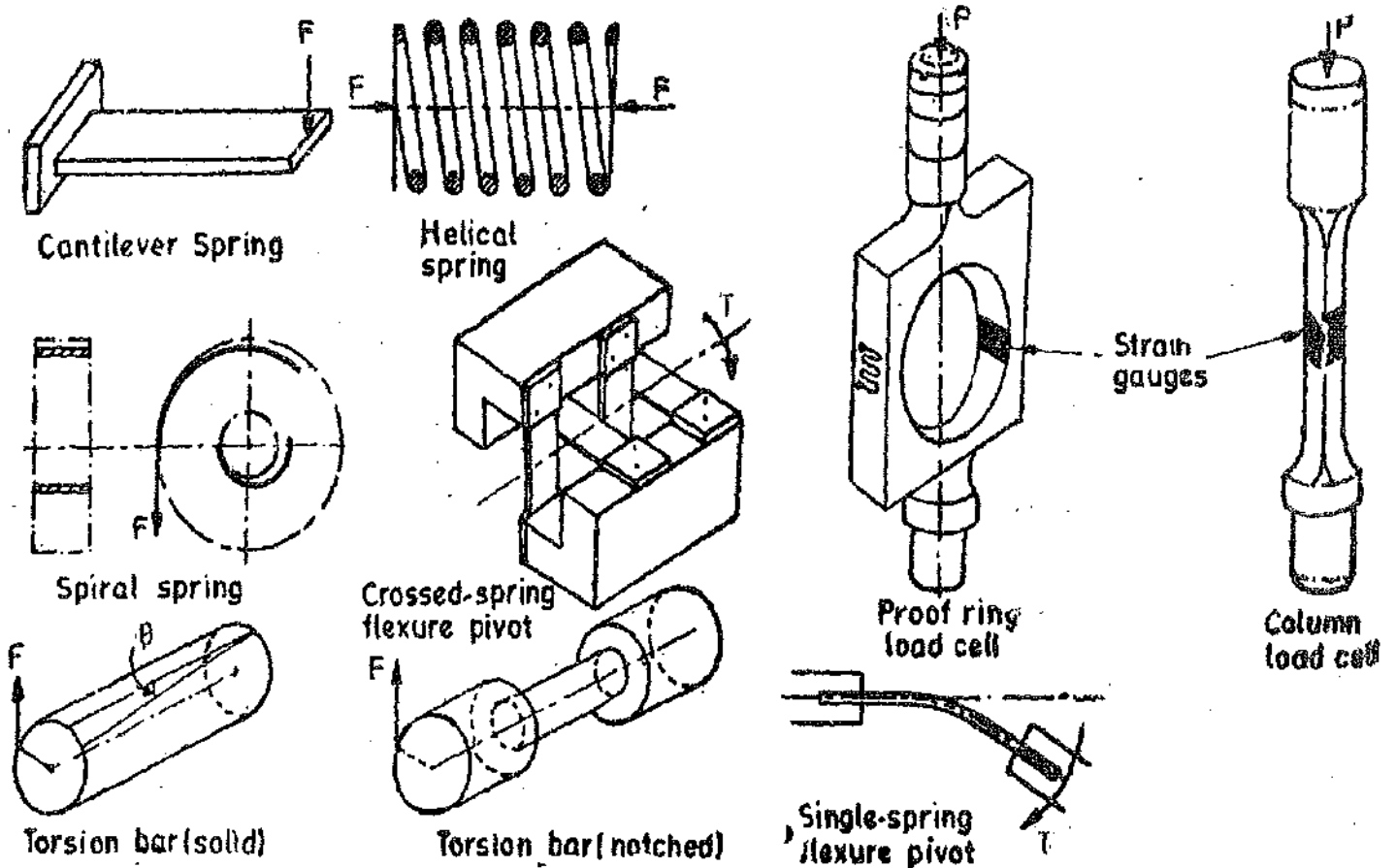

Fig. 25.4. Mechanical springs and elastic elements.

The initial concept of converting an applied force into a displacement is basic to many types of transducers. The mechanical elements which are used to convert the applied force into a displacement are usually elastic members. There are many types of these elastic members. They can be classified into three categories, although some elastic members may fall into a combination of these categories. The three categories are :

- (1) Direct tension or compression type, (2) Bending type, and (3) Torsion type.

25.5. Mechanical Springs

Most of the mechanical measurement systems use springs of one form or another. The displacements are small. Various common springs are shown in Fig. 25.4. These include cantilever, helical and spiral springs, torsion bars, proving rings and spring flexure pivots.

25.5.1. Flat Spiral Springs. Flat spiral springs are used to produce controlling torque in analogue type electrical instruments as has been described earlier on page 130.

25.5.2. Torsion Bars of Shafts. These are primary sensing elements for torque. They are made use of in torque meter. The deflection or twist of the bar is proportional to the applied torque and the deformation is used as a measure of torque.

Some torque meters are designed so that the angular displacement due to twisting of the bar

is measured with a displacement transducer. In others the strain in the surface of the bar, which is proportional to the torque, is measured with the help of strain gauges. The shear strain is a measure of the torque. Torque $T = \frac{\pi G d^3}{16} \Phi$... (25.1)

where G = shear modulus of material of bar ; N/m^2 ,
 d = diameter of the bar ; m, and Φ = angle of twist ; rad.

Sometimes notched bars are used. The notched bar has the advantage that it has a higher sensitivity on account of reduced cross-sectional area of the notched portion.

25.5.3. Proving Rings. They are used for measurement of force, weight or load. The applied force causes a deflection which is measured with the help of electrical transducers.

The common practice for measurement of displacement is to attach a displacement transducer between the top and bottom of the proving ring. When the force is applied, the relative displacement can be measured. An LVDT is normally used for measurement of deflection which is of the order of 1 mm or so. Another method is to use strain gauges for measurement of strain in a ring or a column type of element. This is called a Load Cell. Both compressive as well as tensile stresses can be measured with the help of load cells.

25.5.4. Spring Flexure Pivots. They are widely used in measurement work. The crossed spring flexure pivot is practically a frictionless device. The sensitivity of the device is virtually constant for angular rotations of less than 15°.

25.6. Pressure Sensitive Primary Devices. Most pressure measuring devices use elastic members at the primary stage for sensing of pressure. These elastic members are of many types and convert the pressure into displacement. Many a times they are known as Force Summing Devices. Some of the common force summing devices are :

- (i) Bourdon tubes (ii) Diaphragms and (iii) Bellows.

Fig. 25.5 shows the pressure sensitive primary devices. The principle of working of these

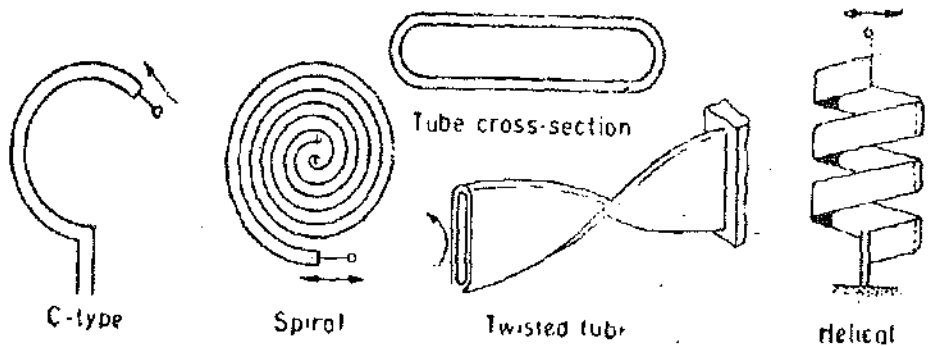

(a) Bourdon Tubes

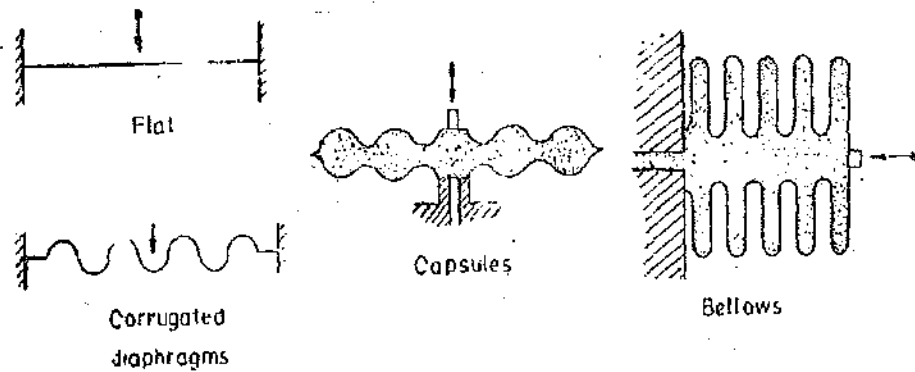

(b) Diaphragms

(c) Bellows

Fig. 25.6 Pressure Sensing Devices,

devices is explained below. The fluid whose pressure is to be measured is made to press the pressure sensitive element and since the element is an elastic member, it deflects and the deflection is proportional to the applied pressure.

25'6'1. Bourdon Tubes. These are designed in various forms like :

(i) C type (ii) spiral (iii) twisted tube and (iv) helical.

The Bourdon tubes are made out of an elliptically sectioned flattened tube bent in such a way as to produce the above mentioned shapes. One end of the tube is sealed or closed and physically held. The other end is open for the fluid to enter. When the fluid whose pressure is to be measured enters the tube, the tube tends to straighten out on account of the pressure. This causes the movement of the free end which is measured. Bourdon tubes normally measure gauge pressure. The materials used for Bourdon tubes are brass, phosphor bronze, beryllium copper, and steel.

25'6'2. Diaphragms. The movement of a diaphragm is a convenient way of sensing a pressure. The unknown pressure is applied to one side of the diaphragm. The edge of the diaphragm is rigidly fixed and this causes a deflection. The displacement of the centre of the diaphragm may be measured in order to know the value of the pressure, because the deflection is directly proportional to the pressure. The diaphragms are of two types :

(i) Flat, and (ii) Corrugated.

The diaphragms may be membranes. However, it is usual to employ thin circular plates which may either be clamped around their circumference between two solid rings, or are machined from a solid piece of metal.

A flat diaphragm is shown in Fig. 25'6.

$$\text{Pressure } P = \frac{256 E t^3 d_m}{3(1-\nu^2)D^4} \text{ N/m}^2 \dots(25'2)$$

where E = Young's modulus ; N/m²
 t = thickness of diaphragm ; m,
 D = diameter of diaphragm ; m,
 ν = Poisson's ratio,
 and d_m = deflection at the centre of the diaphragm ; m.

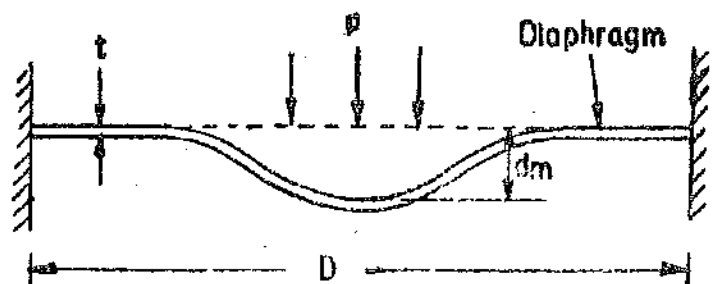

Fig. 25'6. Flat diaphragm.

The above relationship between pressure, P , and the deflection at the centre, d_m , is linear. But linearity holds good as long as $d_m \leq 0.5 t$ and not otherwise.

The maximum stress at the circumference of diaphragm is :

$$s_m = \frac{3D^2 p}{16 t^2} \text{ N/m}^2 \dots(25'3)$$

The lowest natural frequency for air or gas medium is :

$$\omega_n = \frac{20t}{D^2} \sqrt{\left[\frac{E}{3\rho(1-\nu^2)} \right]} \text{ rad/s} \dots(25'4)$$

where ρ = density of diaphragm material, kg/m³.

Corrugated diaphragms give a larger displacement which may be about 2 per cent of diaphragm diameter. In order to obtain larger deflections, two corrugated diaphragms may be welded, brazed or soldered to form a Capsule. The diaphragms are usually made of mild steel.

25'6'3. Bellows. Bellows is a thin walled tube (approximately 0.1 mm thick) having a corrugated shape. It is made from a single piece of metal, usually special brass or stainless steel. Bellows is essentially a pressure activated spring. The displacement of the Bellows for a particular pressure depends upon the type and the thickness of the material used.

It is observed from above that the action of the Bourdon tube, the diaphragm and the Bellows are all based upon the elastic deformations brought out by the force resulting from pressure summation. The deformations or mechanical displacements are normally very small to be detectable with good accuracy by mechanical means and hence secondary transducers which are electrical in nature have to be used invariably and probably compulsarily in order that the output is in an intelligible and interpretable form.

25.7. Temperature Detectors. The principles used for detection of temperature are described below :

(i) The temperature may be detected by differential expansion of two materials as in the case of a **Bimetallic Strips**.

(ii) The temperature may be detected with the help of a **Thermocouple** employing two different metals to generate a thermoelectric emf.

(iii) The change in the value of resistance caused by change in temperature may be used for detection of temperature. This principle is employed by **Resistance Thermometers** and also by **Thermistors**. The temperature detectors have been described later in this chapter.

25.8. Hydropneumatic Devices

The simplest types of hydropneumatic devices are based upon the principle of a simple float or a hydrometer. The simple float is primarily used as a liquid-level detector. The float does not take into account the change in the density of the supporting liquid and it is assumed that a float is always immersed to the same depth. The hydrometer, on the other hand, uses the depth of immersion as a means of detection of variations in the specific gravity of the supporting liquid.

The measurement of flow is very important in a large number of industrial processes. There is a wide range of flow meters based upon many diverse operating principles. These principles may be employed in a variety of ways to suit gases and liquids flowing in pipes or open ducts.

Orifices and venturi tubes are extensively used in measurement of flow. The information obtained is broadly based upon the following two principles :

(i) A pressure drop is produced by constricting (reducing) the area. The reduction in area causes an increase of velocity at the expense of pressure. Thus the change is a measure of velocity i.e. the flow rate.

(ii) The kinetic energy of the flowing fluid is converted into potential energy causing a change in static head.

There are a number of devices used for measurements connected with flow of fluids. Fluid velocity may be measured by reference to aero- or hydrodynamic principles. The Pitot Tube is used for determination of pressures resulting from total flow rate. Vanes in the form of air foils or turbine wheels may be used to detect the fluid flow. Vanes may be elastically supported so that their linear or angular displacements become a measure of the flow.

Example 25.1. A flat circular diaphragm of mild steel has a diameter of 15 mm. For mild steel, Young's modulus $E=200 \text{ GN/m}^2$, and Poisson's ratio $\nu=0.28$.

Find the thickness of the diaphragm if the maximum stress is not to exceed 300 MN/m^2 when the pressure is 300 kN/m^2 . Find the deflection at the centre for a pressure of 150 kN/m^2 .

Solution. From Eqn. 25.3, stress $s = \frac{3D^2p}{16t^3}$

$$\begin{aligned} \therefore \text{Thickness} \quad t &= \sqrt{\frac{3D^2p}{16s}} = \sqrt{\frac{3 \times (15 \times 10^{-3})^2 \times 300 \times 10^3}{16 \times 300 \times 10^6}} \\ &= 0.205 \times 10^{-3} \text{ m} = 0.205 \text{ mm.} \end{aligned}$$

The deflection at the centre is given by Eqn. 24.2.

$$d_m = \frac{3(1-\nu^2)D^4p}{256Et^3} = \frac{3(1-0.28^2)(15 \times 10^{-3})^4 \times 150 \times 10^3}{256 \times 200 \times 10^9 \times (0.205 \times 10^{-3})^3} = 47.3 \times 10^{-6} \text{ m} = 0.0475 \text{ mm.}$$

Example 25.2. A torsion bar of 30 mm diameter is used for measurement of a torque of 100 Nm. Calculate the angle of twist if shear modulus of mild steel is $80 \times 10^9 \text{ N/m}^2$.

Solution. From Eqn. 25.1, the angle of twist is :

$$\theta = \frac{16T}{\pi G d^3} = \frac{15 \times 100}{\pi (80 \times 10^9)(30 \times 10^{-3})^3} = 23.5 \times 10^{-3} \text{ rad} = 0.81'$$

25.9. Electric Transducers

The art of electrical measurements has been chiefly used for measurement of electrical quantities but its value in making measurements of non-electrical quantities in this new era of automation is rapidly growing. In order to measure non-electrical quantities a detector is used which usually converts the physical quantity into a displacement. This displacement actuates an electric transducer, which acting as a secondary transducer, gives an output that is electrical in nature. The electrical quantity so produced is measured by standard methods used for electrical measurements. The result (electrical output) gives the magnitude of the physical quantity or condition being measured.

The electrical signal may be a current or a voltage or a frequency and production of these signals is based upon, resistive, capacitive, inductive effects etc.

The first stage of a measurement system may simply be called a transducer stage instead of detector transducer stage by redefining a transducer. A transducer, in general form, may be defined as a device which converts energy from one form to another. However, this definition has to be restricted, many a time especially in the field of electrical instrumentation. Keeping this restriction in view, transducer may be defined as a device which converts a physical quantity or a physical condition into an electrical signal. Another name for a transducer is pick up.

25.10. Advantages of Electrical Transducers

There are a number of transducers which transform a variety of physical quantities and phenomena into electrical signals. The reasons for transforming a physical phenomenon into electrical form are numerous. The advantages of converting physical quantities into analogous electrical quantities are :

(i) Electrical amplification and attenuation can be done easily and that too with static devices.

(ii) The mass-inertia effects are minimized. In fact, when dealing with electrical or electronic signals, the inertia effects are due to electrons which have negligible mass. In many situations, we do not come across mass or inertia problems at all.

(iii) The effects of friction are minimized.

(iv) The electrical or electronic systems can be controlled with a very small power level.

(v) The electrical output can be easily used, transmitted and processed for the purpose of measurement.

(vi) Telemetry is used in almost all sophisticated measurement systems. The entire aerospace research and development is based upon telemetry and remote control. The ever enlarging field of radio monitoring in space research has left us with no alternative but to resort to electronic means. This completely eliminates the data transmission through mechanical means and hence electrical and electronic principles have to be employed for these conditions. The remote indication or recording is an essential part of modern day technology.

(vii) There has been an explosive development in the field of electronic components and devices. This development is on account of the fact that electronic devices are very amenable to miniaturization. Components which are compact, have always an, advantage. Miniaturization on account of use of ICs (Integrated Circuits) has completely revolutionised the field of instrumentation.

In short, it can be said that the reasons for transforming a physical phenomenon into electrical form is that the electrical output can be easily used, transmitted and processed for the

purposes of measurement. Modern digital computers make the use of these transducers absolutely essential.

When the definition of transducer is confined to a device that covers the entire detector transducer stage, wherein the transducer converts a non-electrical quantity into an analogous electrical signal, the transducer may be thought of consisting of two important and closely related parts. These two parts are:

(i) Sensing Element, and (ii) Transduction Element.

In addition there may be many other auxiliary parts, such as amplifiers and other signal processing equipment, power supplies, calibrating and reference sources, and mechanical mounting features.

1. Sensing or Detector Element. A detector or a sensing element is that part of a transducer which responds to a physical phenomenon or a change in a physical phenomenon. The response of the sensing element must be closely related to the physical phenomenon.

2. Transduction element. A transduction element transforms the output of a sensing element to an electrical output. The transduction element, in a way, acts as a secondary transducer.

25.11. Classification of Electrical Transducers

There are many basis on which electrical transducers may be classified. They can be classified according to application, method of energy conversion, nature of output signals and so on. All these classifications mainly overlap each other and a sharp distinction between different types is rather difficult.

25.12. Primary and Secondary Transducers

We have already described a particular classification of transducers. They are:

25.12.1. Primary Transducers. These are detectors which sense a physical phenomenon. According to our latest definition of transducers which says that a transducer converts a physical phenomenon to an electrical output. The transducer which falls in this category is thermocouple. The thermocouple's hot junction senses the radiant heat energy and directly converts it into an analogous electrical output which is a voltage.

25.12.2. Secondary Transducers. The physical phenomenon is first sensed by a detector and the signal is converted into an analogous output. This analogous output is then converted into an electrical signal by a secondary transducer. An example of a use of secondary transducer is in most situations converted into an analogous output. This analogous output is then converted into an electrical signal by a secondary transducer. An example of a use of secondary transducer is shown in Fig. 25.2 where the LVDT along with a Bourdon tube is used for measurement of pressure.

25.13. Active and Passive Transducers

Transducers may also be classified according to whether they are self-generating (active) or externally powered (passive) type.

25.13.1. Active Transducers. These transducers develop their own voltage or current. The energy required for production of an output signal is obtained from the physical phenomenon being measured. Piezoelectric transducers are an example of active transducers.

25.13.2. Passive Transducers. These transducers are known as externally-powered transducers. These transducers derive the power required for energy conversion from an external power source. However, they may absorb some energy from the physical phenomenon under study.

25.14. Analogue and Digital Transducers

The transducers can be classified on the basis of the type of output. The output may be a continuous function of time or may be in discrete steps.

25.14.1. Analogue Transducers. These transducers convert the input physical phenomenon into an analogous output which is a continuous function of time. Thus a strain gauge, an LVDT, a thermocouple or a thermistor may be called as analogue transducers.

25'14.2. Digital Transducers. These transducers convert the input physical phenomenon into an electrical output which is in the form of pulses.

Fig. 25'7 shows a digital linear displacement transducer. This transducer uses digital code marks to identify the position of a movable piece by a binary system of notation. The position is given out as a train of digital pulses.

At the binary system uses only two symbols 0 and 1 (Binary systems are explained in Appendix A) it can easily be represented by opaque and transparent areas on a glass scale. Another alternative is to use conducting and non-conducting areas on a metal scale. In Fig. 25'7, a scale is constructed to show the linear position of a movable objects. This digital transducer uses 5 digits. The complete binary number denoting the position is obtained by scanning the pattern across the scale at a stationary index mark. Glass scales can be read optically by means of a light source, an optical system and photocells. Metal scales are scanned by brushes making electrical contact with individual tracks.

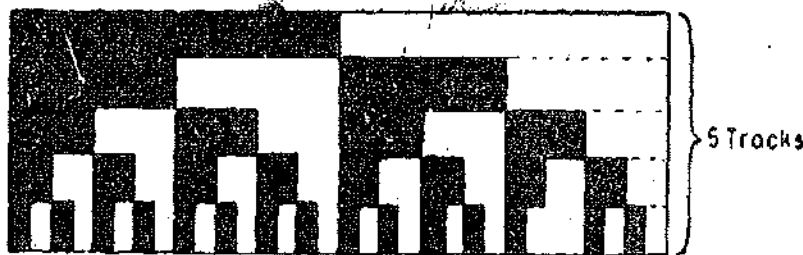

Fig. 25'7. Digital displacement transducer using 5-digit scale for digital indication of linear position of a movable object.

25'15. Electrical Phenomena used in Transducers

The transducers may be classified into different categories depending upon the principle employed by their transduction elements to convert the physical phenomenon (input) into output electrical signals. The different electrical phenomena employed in transduction elements of transducers are listed below. These phenomena may be combined with appropriate primary sensing elements (detectors) to produce a variety of transducers.

These phenomena are :

1. Resistive. 2. Inductive. 3. Capacitive. 4. Electromagnetic. 5. Piezoelectric. 6. Ionization.
7. Photoelectric or Photo-emissive. 8. Photoconductive or Photoresistive. 9. Photovoltaic. 10. Potentiometric. 11. Thermo-electric or Thermo-voltaic. 12. Electrokinetic.

Table 25'2 on page 756-757 shows a classification of transducers according to electrical principles involved. Although it is impossible to classify the sensors, the devices listed in Table 25'2 do represent a wide cross-section of commercially available transducers in instrumentation engineering.

25'16. Resistive Transducers

It is generally seen that methods which involve the measurement of change in resistance are preferred to those employing other variables. This is because both alternating as well as direct currents and voltages are suitable for resistance measurements.

The resistance of a metal conductor is expressed by a simple equation that involves a few physical quantities. The relationship is $R = \rho L/A$.

where R = resistance ; Ω ,

L = length of conductor ; m,

A = cross-sectional area of conductor ; m^2 , and ρ = resistivity of conductor material ; $\Omega\text{-m}$.

Any method of varying one of the quantities involved in the above relationship can be the design basis of an electrical resistive transducer. There are a number of ways in which resistance can be changed by a physical phenomenon. The translational and rotational potentiometers which work on the basis of change in the value of resistance with change in length of the conductor can be used for measurement of translational or rotary displacements. Strain gauges work on the principle that the resistance of a conductor or a semi-conductor changes when strained. This property can be used for measurement of displacement, force and pressure. The resistivity of materials changes with change of temperature thus causing a change of resistance. The property may be used for measurement of temperature. Thus electrical resistance transducers have a wide field of application.

TABLE 25.2
Types of Electrical Transducers

Electrical parameter and class of transducer	Principle of operation	Typical applications
Passive transducers (externally powered)		
Resistance		
Potentiometer device	Positioning of the slider by an external force varies the resistance in a potentiometer or a bridge circuit.	Pressure, displacement.
Resistance strain gauge	Resistance of a wire or semiconductor is changed by elongation or compression due to externally applied stress.	Force, torque, displacement.
Pirani gauge or hot wire meter	Resistance of a heating element is varied by convection cooling of a stream of gas.	Gas flow, gas pressure.
Resistance thermometer	Resistance of pure metal wire with a large positive temperature co-efficient of resistance varies with temperature.	Temperature, radiant heat
Thermistor	Resistance of certain metal oxides with negative temperature coefficient of resistance varies with temperature.	Temperature, flow.
Resistance hygrometer	Resistance of a conductive strip changes with moisture content.	Relative humidity.
Photoconductive cell	Resistance of the cell as a circuit element varies with incident light.	Photosensitive relay
Capacitance Variable capacitance pressure gauge	Distance between two parallel plates is varied by an externally applied force	Displacement, pressure.
Capacitor microphone	Sound pressure varies the capacitance between a fixed plate and a movable diaphragm.	Speech, music, noise.
Dielectric gauge	Variation in capacitance by changes in the dielectric.	Liquid level, thickness.
Inductance		
Magnetic circuit transducer	Self-inductance or mutual inductance of a.c. excited coil is varied by changes in the magnetic circuit.	Pressure, displacement.

Reluctance pickup	Reluctance of the magnetic circuits is varied by changing the position of the iron core of a coil.	Pressure, displacement vibration, position.
Differential transformer	The differential voltage of two secondary windings of a transformer is varied by positioning the magnetic core through an externally applied force.	Pressure, force, displacement, position.
Eddy current gauge	Inductance of a coil is varied by the proximity of an eddy current plate.	Displacement, thickness.
Magnetostriction gauge	Magnetic properties are varied by pressure and stress.	Force, pressure, sound.
Voltage and Current		
Hall effect pickup	A potential difference is generated across a semiconductor plate (germanium) when magnetic flux interacts with an applied current.	Magnetic flux, current.
Ionization chamber	Electron flow induced by ionization of gas due to radio-active radiation.	Particle counting, radiation.
Photoemissive cell	Electron emission due to incident radiation upon photo-emissive surface.	Light and radiation.
Photomultiplier tube	Secondary electron emission due to incident radiation on photosensitive cathode.	Light and radiation, photo-sensitive relays.
Self-generating transducers (no external power)		
Thermocouple and thermopile	An emf is generated across the junction of two dissimilar metals or semiconductors when that junction is heated.	Temperature, heat flow, radiation.
Moving coil generator	Motion of a coil in a magnetic field generates a voltage.	Velocity, vibration.
Piezoelectric pickup	An emf is generated when an external force is applied to certain crystalline materials, such as quartz.	Sound, vibration, acceleration, pressure changes.
Photovoltaic	A voltage is generated in a semiconductor junction device when radiant energy stimulates the cell.	Light meter, solar cell.

25.17. Potentiometers

Basically, a resistive potentiometer, or simply a pot, (A potentiometer used for the purposes of voltage division is called a pot) consists of a resistance element provided with a sliding contact. This sliding contact is called a wiper. The motion of sliding contact may be translatory or rotational. Some pots use the combination of the two motions, *i.e.* translational as well as rotational. These potentiometers have their resistive element in the form of helix and thus, are called helipot.

The translational resistive elements are straight devices and have a stroke of about 2 mm to 0.5 m. The rotational resistive devices are circular in shape and are used for measurement of angular displacement. They have a range of 10° to 60 full turns. The helical resistive elements are multiturn rotational devices which can be used for measurement of either translational or rotary motion. The resistance element of a potentiometer may be excited either with a d.c. or an a.c. voltage source. The pot, is thus, a passive transducer since it requires an external power source for its operation.

The resistance elements of potentiometers are wire wound but some other commonly used resistive materials are cermet, hot moulded carbon, carbon film and thin metal films.

Fig. 25.8 shows that the schematic diagrams of a translational, single turn rotational and multiturn rotational helix potentiometers.

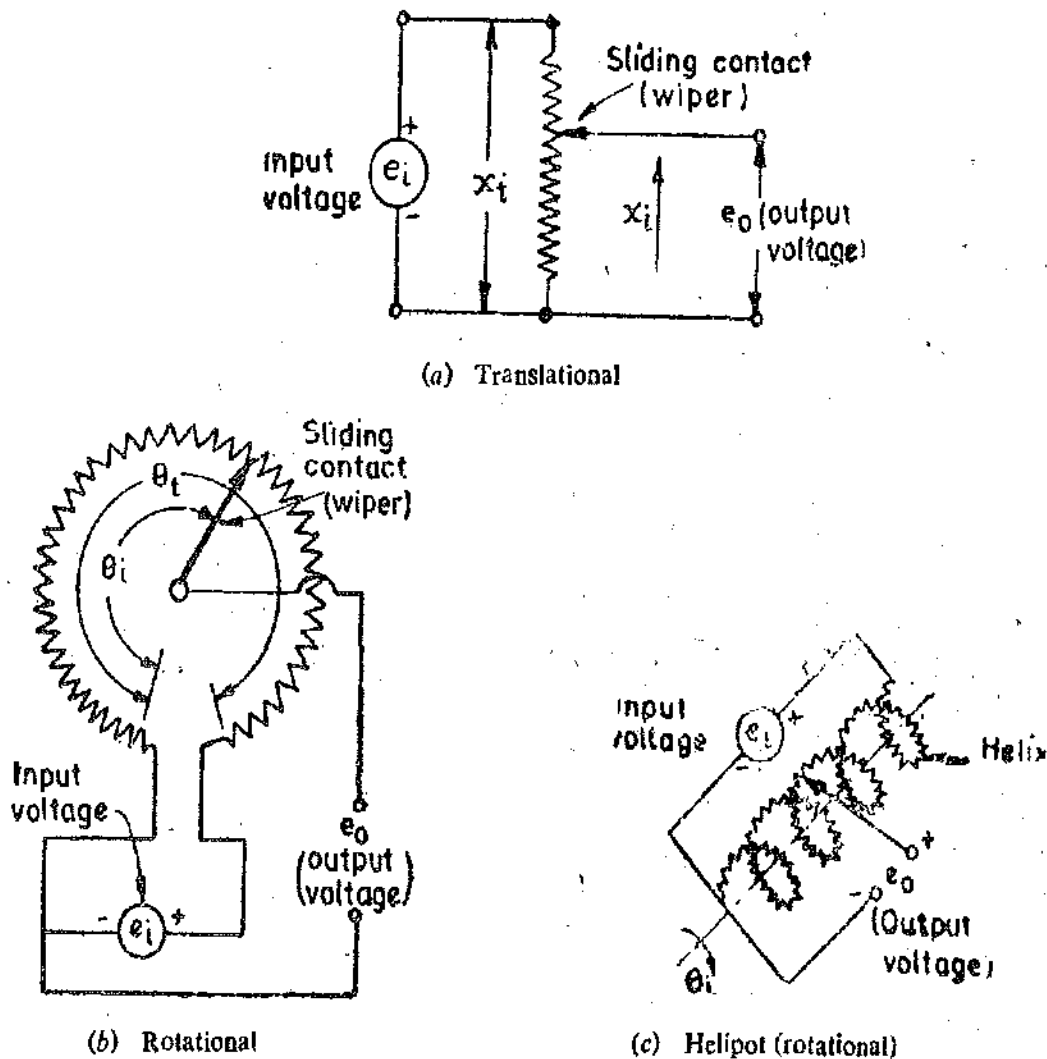

Fig. 25.8. Resistive potentiometers.

Let us confine our discussion to d.c. excited potentiometers. Consider a translational potentiometer as shown in Fig. 25.8 (a).

Let e_i = input voltage ; V , R_t = total resistance of potentiometer ; Ω ,
 x_i = total length of a translational pot ; m ,

x_i = displacement of the slider from its 0 position ; m,

and e_0 = output voltage ; V.

If the distribution of the resistance with respect to translational movement is linear, the resistance per unit length is R_p/x_t .

The output voltage under ideal conditions is :

$$e_0 = \left(\frac{\text{resistance at the output terminals}}{\text{resistance at the input terminals}} \right) \times \text{input voltage}$$

$$= \left[\frac{(R_p/x_t \times x_i)}{R_p} \right] \times e_i = \frac{x_i}{x_t} e_i \quad \dots(25.5)$$

Thus under ideal circumstances, the output voltage varies linearly with displacement as shown in Fig. 25.9 (a).

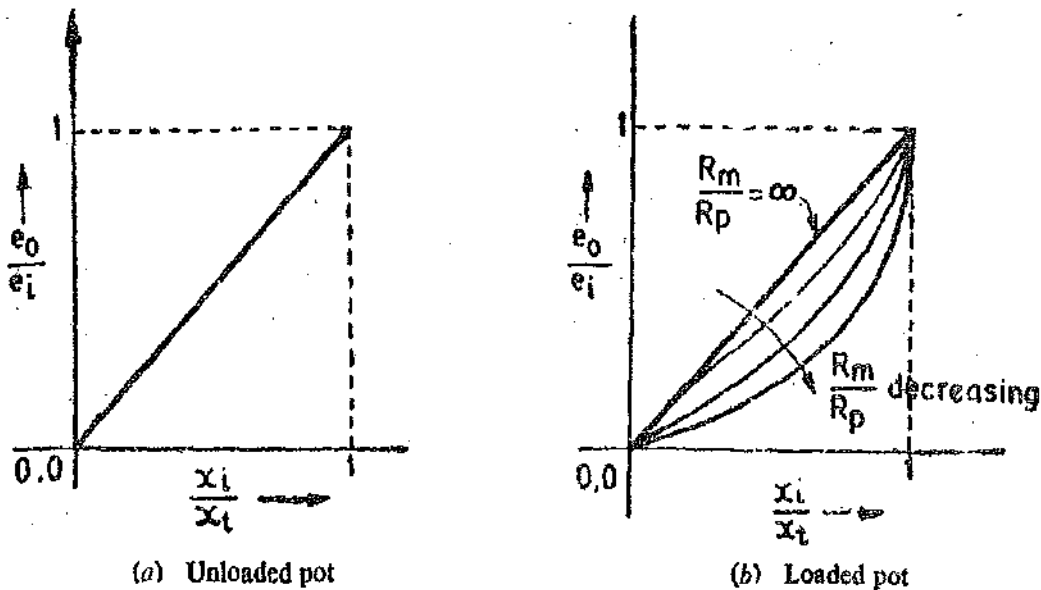

Fig. 25.9. Characteristics of potentiometers.

Sensitivity $S = \frac{\text{output}}{\text{input}} = \frac{e_0}{x_i} = \frac{e_i}{x_t} \quad \dots(25.6)$

Thus under ideal conditions the sensitivity is constant and the output is faithfully reproduced and has a linear relationship with input. The same is true of rotational motion.

Let θ_i = input angular displacement in degrees, and θ_t = total travel of the wiper in degrees.

\therefore Output voltage $e_0 = e_i / \theta_i / \theta_t \quad \dots(25.7)$

This is true of single turn potentiometers only.

The circuits shown in Fig. 25.8 are called potentiometer dividers since they produce an output voltage which is a fraction of the input voltage. Thus the input voltage is "divided". The potential divider is a device for dividing the potential in a ratio determined by the position of the sliding contact.

Eqs 25.6 and 25.7 are based upon the assumption that the distribution of resistance with respect to linear or angular displacement are uniform and the resistance of the voltage measuring device (i.e. output device) is infinite. However, in practice, the output terminals of the pot are connected to a device whose impedance is finite. Thus when an electrical instrument, which forms a load for the pot, and is connected across

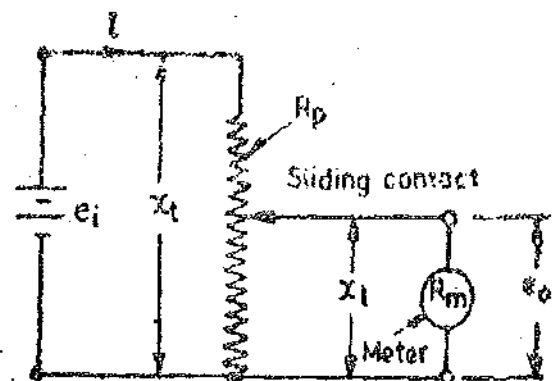

Fig 25.10. Loaded potentiometer.

the output terminals. The indicated voltage is less than that given by Eqn. 25'6. The error, which is referred to as a loading error is caused by the input resistance of the output device.

Let us consider the case of a translational potentiometer as shown in Fig. 25'10. Let the resistance of a meter or a recorder monitoring the output be R_m .

As explained earlier if the resistance across the output terminals is infinite, we get a linear relationship between the output and the input voltage.

$$e_0 = (x_i/x_t)e_i = Ke_i \quad \dots(25'8)$$

However, under actual conditions the resistance, R_m , is not infinite. This causes a non-linear relationship between the output and input voltages.

25'17'1. Loading Effect. The resistance of the parallel combination of load resistance and the portion of the resistance of the potentiometer is :

$$\frac{(x_i/x_t) R_p R_m}{(x_i/x_t) R_p + R_m} = \frac{K R_p R_m}{K R_p + R_m} \quad \dots(25'9)$$

The total resistance seen by the source is :

$$R = R_p (1 - K) + \frac{K R_p R_m}{K R_p + R_m} = \frac{K R_p^2 (1 - K) + R_p R_m}{K R_p + R_m} \quad \dots(25'10)$$

$$\therefore \text{Current } i = \frac{e_i}{R} = \frac{e_i (K R_p + R_m)}{K R_p^2 (1 - K) + R_p R_m} \quad \dots(25'11)$$

The output voltage under loaded conditions is :

$$e_0 = e_i - i R_m (1 - K) = \frac{e_i K}{1 + (R_p/R_m)K - (R_p/R_m)K^2} \quad \dots(25'12)$$

$$= \frac{e_i K}{K(1 - K)(R_p/R_m) + 1} \quad \dots(25'13)$$

The ratio of output to input voltage under loaded conditions is :

$$\frac{e_0}{e_i} = \frac{K}{K(1 - K)(R_p/R_m) + 1} \quad \dots(25'14)$$

The Eqn. 25'14 shows that there exists a non-linear relationship between output voltage e_0 , and input voltage e_i . In case $R_m = \infty$, $\frac{e_0}{e_i} = K$.

It is evident from Eqn. 25'14, that as the ratio of R_m/R_p decreases, the non-linearity goes on increasing. This is shown in Fig. 25'9 (b). Thus, in order to keep linearity the value of R_m/R_p should be as large as possible. However, when we have to measure the output voltage with a given meter, the resistance of the potentiometer, R_p , should be as small as possible.

\therefore Error = output voltage under load - output voltage under no load

$$= \frac{e_i K}{[K(1 - K)(R_p/R_m) + 1]} - e_i K = e_i \left[\frac{K^2 (K - 1)}{K(1 - K) + (R_m/R_p)} \right] \quad \dots(25'15)$$

Based upon full-scale output, this relationship may be written as :

$$\text{Percentage error} \\ \% \epsilon = \left[\frac{K^2 (K - 1)}{K(1 - K) + (R_m/R_p)} \right] \times 100 \quad \dots(25'16)$$

Except for the two end points where $K=0$ i.e. $x_t=0$ and $K=1$ where $x_t=x_i$ the error is always negative. Fig. 25'11 shows a plot of the variation in error with the slider position for different ratios of the load (meter) resistance to the potentiometer resistance.

The error as indicated in Fig. 25'11 is actually negative. Examining Fig. 25'11, the maximum error is about 12 per cent of full scale if $R_m/R_p=1$. This error drops down to about 1.5 per cent when $R_m/R_p=10$. For values of $R_m/R_p > 10$ the position of maximum error occurs in the vicinity of $x_i/x_t=0.67$.

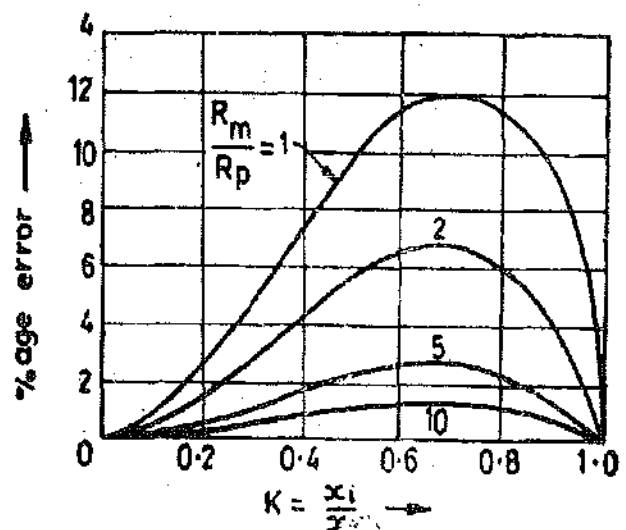

Fig. 25'11. Variation of error due to loading effect of a potentiometer.

$$\text{Maximum percentage error } \epsilon_{max} = 15 \times (R_p/R_m) \dots(25'17)$$

25'17.2. Power Rating of Potentiometers. The potentiometers are designed with a definite power rating which is related directly to their heat dissipating capacity. The manufacturer normally designs a series of potentiometers of single turn with a diameter of 50 mm with a wide range of ohmic values ranging from 100 Ω to 10 kΩ in steps of 100 Ω. These potentiometers are essentially of the same size and of the same mechanical configuration. They have the same heat transfer capabilities. Their rating is typically 5 W at an ambient temperature of 21°C. This limits their input excitation voltage. Since power $P = e_i^2/R$, the maximum input excitation voltage that can be used is :

$$(e_i)_{max} = \sqrt{PR_p} \text{ volt} \dots(25'18)$$

25'17.3. Linearity and Sensitivity. It has been explained earlier that in order to achieve a good linearity, the resistance of potentiometer R_p , should be as low as possible when using a particular meter.

In order to get a high sensitivity the output voltage e_o should be high which in turn requires a high input voltage, e_i . Due to limitations of power dissipation as is clear from Eqn. 25'18, the input voltage is limited by the resistance of the potentiometer. In order to keep the power dissipation at a low level, the input voltage should be small and resistance of the potentiometer should be high. Thus for a high sensitivity, the input voltage should be large and this calls for a high value of resistance R_p . On the other hand if we consider the linearity, the resistance of potentiometer R_p , should be as low as possible. The resistance of the potentiometer, R_p , cannot be made low because if we do so the power dissipation goes up with the result that we have to make the input voltage small to keep down the power dissipation to the acceptable level. This results in lower sensitivity.

Thus linearity and sensitivity are two conflicting requirements. If R_p is made small, the linearity improves, but a low value of R_p requires a lower input voltage e_i in order to keep down the power dissipation and a low value of e_i results in a lower value of output voltage e_o resulting in lower sensitivity. Thus the choice of potentiometer resistance, R_p , has to be made considering both the linearity and sensitivity and a compromise between the two conflicting requirements has to be struck.

Typical values of sensitivity are of the order of 200 mV/degree for a rotational potentiometer and 200 mV/mm for a translational potentiometer. The short stroke devices have generally a high values of sensitivity.

25'17.4. Construction of Potentiometers. The resolution of the potentiometers influences the construction of their resistance elements. Normally, the resistive element is a single wire of conducting material which gives a continuous stepless variation of resistance as the wiper travels over it. Such

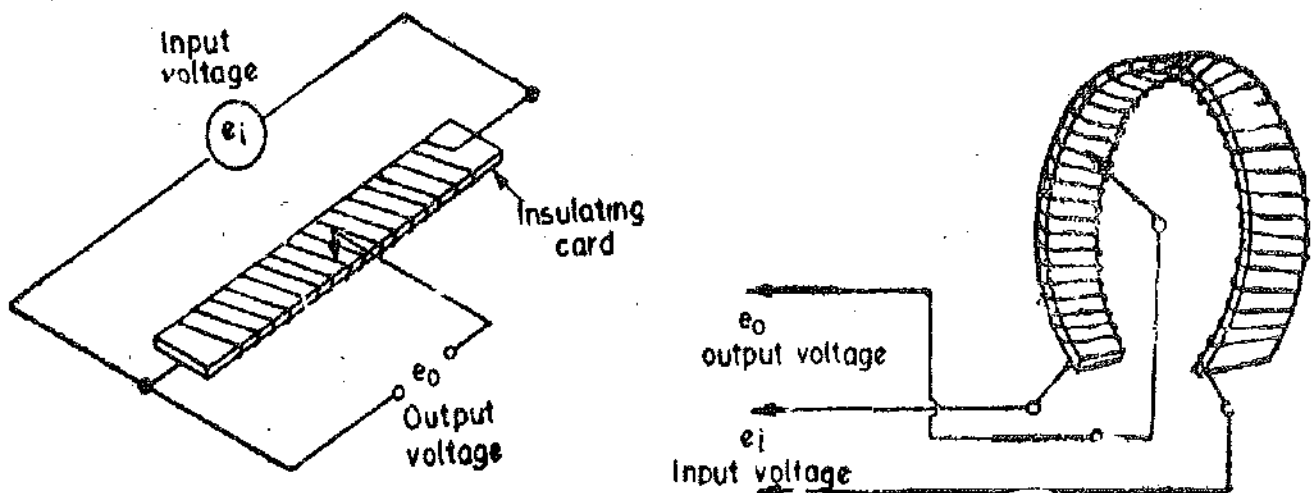

(a) Linear potentiometer.

(b) Circular potentiometer.

Fig. 25'12. Wire wound potentiometers.

potentiometers are available but their length (in the case of translational potentiometers) and diameter (in the case of rotational potentiometers) restrict their use on account of space considerations.

The resolution of the potentiometers is dependent upon the construction of the resistive element and in order to get high values of resistance in small space wire wound potentiometers are used extensively. The resistance wire is wound on a mandrel or a card for translational displacement as shown in Fig. 25 12 (a). For the measurement of rotational motion these mandrels or cards are formed into a circle or a helix. This is shown in Fig. 25 12 (b). If wire wound type of construction is adopted, the variation of resistance is not a linear continuous change but is in small steps as the sliding contact (wiper) moves from one turn to another. This is shown in Fig. 25 13.

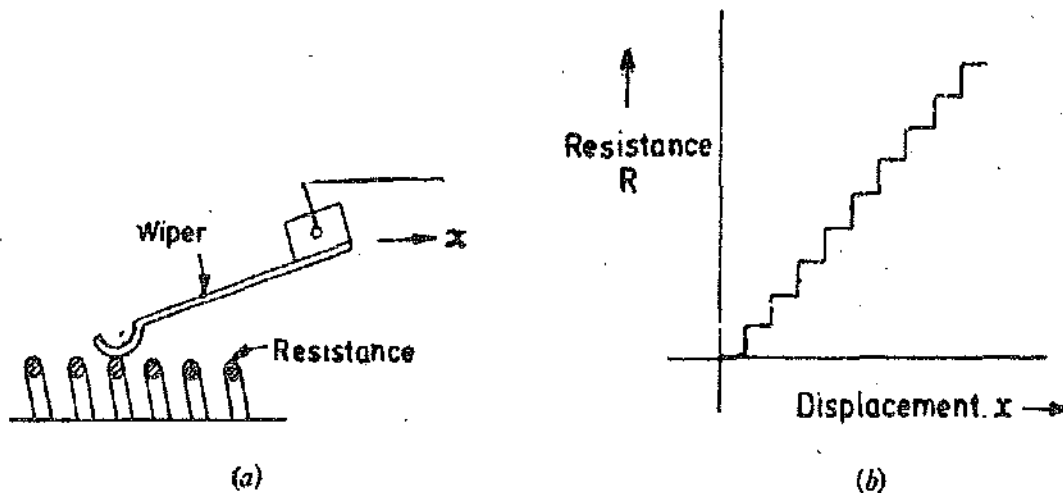

Fig. 25.13. Translational potentiometer and its characteristics.

Since the variation in resistance is in steps the resolution is limited. For instance, a translational potentiometer has about 500 turns of a resistance wire on a card of 25 mm in length and for this device the resolution is limited to $25/500 = 0.05 \text{ mm} = 50 \mu\text{m}$.

The actual practical limit is 20 and 40 turns per mm. Thus for translational devices the resolution is limited to 25–50 μm .

For rotational devices, the best angular resolution = $\frac{(50-100) \times 10^{-3}}{D}$ degrees ... (25.19)

where D = diameter of the potentiometer ; m.

In order to get higher resolution, thin wires which have a high resistance have to be put close to each other and they can be closely wound on account of their small diameter. Thus the resolution and total resistance are interdependent.

In case a fine resolution and high resistance are required a carbon film or a conductive-plastic resistance elements are used. Carbon film resistive elements have a resolution of 12.5 μm .

25.17.5. Helipot. The resolution can be increased by using multi-turn potentiometers. These are called helipot. The resistance element is in the form of a helix and the wiper travels along a "lead screw". The number of turns is still limited to 200 to 400 per cm but an increase in resolution can be obtained by using a gearing arrangement between the shaft whose motion is to be measured and the potentiometer shaft. As an example, one rotation of the measured shaft can cause 10 rotations of the potentiometer shaft. This increases the resolution of the measured shaft motion by 10 times. Multiturn potentiometers are available to about 60 turns.

Similar, magnifying or amplifying techniques can be used for translational motion as well.

25.17.6. Types of Potentiometers and their Characteristics. There are five types of potentiometers available :

1. Wire Wound. These use nickel chromium, nickel copper, or some other precious resistance elements. Wire wound potentiometers can carry relatively large currents at high temperatures. Their temperature co-efficient is usually small, is of the order $20 \times 10^{-6} \Omega/\Omega\text{-}^\circ\text{C}$ or less and also they are relatively inexpensive. Their resolution is about 0.05 mm and is limited by the number of turns. Multiturn potentiometers using 3 to 10 turn units are used when the potentiometer is required to have close settings.

The interwinding capacitance between turns and between winding and arm, housing etc. limits the use of wire wound potentiometers to low frequencies. The response is limited to about 5 Hz.

2. Cermet. Cermet uses precious metal particles fused into ceramic base. These fused metal particles act as resistance elements. The advantages of using Cermet are large power ratings at high temperatures, low cost and moderate temperature coefficients of the order 100×10^{-6} to $200 \times 10^{-6} \Omega/\Omega\text{-}^\circ\text{C}$. Cermet is very useful for a.c. applications.

3. Hot Moulded Carbon. The resistance element is fabricated by moulding together a mixture of carbon and a thermosetting plastic binder. Hot moulded carbon units are useful for a.c. applications.

4. Carbon Film. A thin film of carbon deposited on a non-conductive base forms the resistance element. The advantage of carbon film potentiometers is their low cost. Temperature coefficients are upto $1000 \times 10^{-6} \text{-}^\circ\text{C}$.

5. Thin Metal Film. A very thin, vapour deposited layer of metal on glass or ceramic base is used as a resistance element. The advantages of this potentiometer are its excellent resistance to changes in environments and use on a.c. The cost is also moderate.

Advantages and Disadvantages. Resistance potentiometers have the following major advantages :

(i) They are inexpensive.

(ii) They are simple to operate and are very useful for applications where the requirements are not particularly severe.

(iii) They are very useful for measurement of large amplitudes of displacement.

(iv) Their electrical efficiency is very high and they provide sufficient output to permit control operations without further amplification.

(v) It should be understood that while the frequency response of wire wound potentiometers is limited, the other types of potentiometers are free from this problem.

(vi) In wire wound potentiometers the resolution is limited while in Cermet and metal film potentiometers, the resolution is infinite.

The disadvantages are :

(i) The chief disadvantage of using a linear potentiometer is that they require a large force to move their sliding contacts (wipers).

(ii) The other problems with sliding contacts are that they can be contaminated, can wear out, become misaligned and generate noise. So the life of the transducer is limited. However, recent developments have produced a roller contact wiper which, it is claimed, increases the life of the transducer by 40 times.

Example 25.3. A linear resistance potentiometer is 50 mm long and is uniformly wound with a wire having a resistance 10,000 Ω . Under normal conditions, the slider is at the centre of the potentiometer. Find the linear displacement when the resistance of the potentiometer as measured by a Wheatstone bridge for two cases is :

(i) 3850 Ω , and (ii) 7560 Ω .

Are the two displacements in the same direction ?

If it is possible to measure a minimum value of 10 Ω resistance with the above arrangement, find the resolution of the potentiometer in mm.

Solution. The resistance of potentiometer at the normal position = $10,000/2 = 5000 \Omega$.

(i) Resistance of potentiometer wire per unit length = $10,000/50 = 200 \Omega/\text{mm}$.

(ii) Change in resistance of potentiometer from its normal position = $5000 - 3850 = 1150 \Omega$.

\therefore Displacement = $\frac{1150}{200} = 5.75 \text{ mm}$.

(iii) Change in resistance of potentiometer from its normal position = $7560 - 5,000 = 2,560 \Omega$.

\therefore Displacement = $\frac{2560}{200} = 12.55 \text{ mm}$.

Since one of the displacements represents a decrease and the other represents an increase in resistance of the potentiometer as compared with the resistance of the potentiometer at its normal position, the two displacements are in the opposite direction.

Resolution = minimum measurable value of resistance $\times \frac{\text{mm}}{\Omega} = 10 \times \frac{1}{200} = 0.05 \text{ mm}$.

Example 25.4. A variable potential divider has a total resistance of $2 \text{ k}\Omega$ and is fed from a 10 V supply. The output is connected across a load resistance of $5 \text{ k}\Omega$. Determine the loading error for the slider positions corresponding to $x_i/x_t = 0, 0.25, 0.5, 0.75$ and 1.0 . Use the results to plot a rough graph of loading error against the ratio x_i/x_t .

Solution. From Eqn. 25.16, the percentage loading error = $\left[\frac{K^2(K-1)}{K(1-K) + (R_m/R_p)} \right] \times 100$

In terms of input voltage the error = $\left[\frac{K^2(K-1)}{K(1-K) + (R_m/R_p)} \right] \alpha$

(i) when $K = \frac{x_i}{x_t} = 0$, Error = $\left[\frac{0(0-1)}{0(1-0) + (5000/2000)} \right] \times 10 = 0$.

(ii) when $K = 0.25$, Error = $\left[\frac{(0.25)^2(0.25-1)}{0.25(1-0.25) + (5000/2000)} \right] \times 10 = -0.174 \text{ V}$.

(iii) when $K = 0.5$, Error = $\left[\frac{(0.5)^2(0.5-1)}{0.5(1-0.5) + (5000/2000)} \right] \times 10 = -0.434 \text{ V}$.

(iv) when $K = 0.75$, Error = $\left[\frac{(0.75)^2(0.75-1)}{0.75(1-0.75) + (5000/2000)} \right] \times 10 = -0.524 \text{ V}$.

(v) when $K = 1$, Error = $\left[\frac{(1)^2(1-1)}{1(1-1) + (5000/2000)} \right] \times 10 = 0 \text{ V}$.

A rough graph of error versus x_i/x_t is shown in Fig. 25.14 (The errors are negative).

Example 25.5 The output of a potentiometer is to be read by a recorder of $10 \text{ k}\Omega$ input resistance. Non-linearity must be held to 1 per cent. A family of potentiometers having a thermal rating of 5 W and resistances ranging from 100Ω to $10 \text{ k}\Omega$ in steps of 100Ω is available. Choose from the family the potentiometer that has the greatest possible sensitivity and also meets other requirements. Find the maximum excitation voltage permissible with this potentiometer. What is the sensitivity if the potentiometer is a single turn (360°) unit?

Solution :

From Eqn. 25.17, the maximum possible percentage linearity = $15 R_p/R_m$.

Therefore, the maximum resistance of potentiometer, with 1 per cent linearity and a recorder with a resistance $R_m = 10,000 \Omega$ across it is :

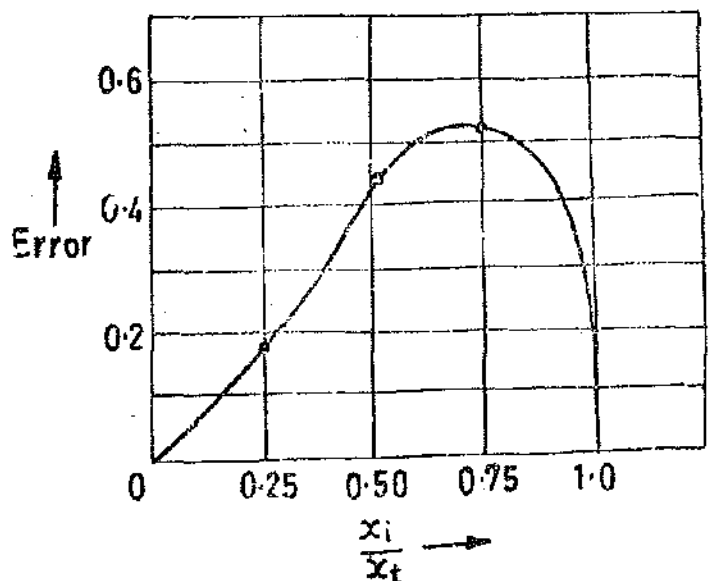

Fig. 25.14

$$R_p = \frac{1 \times R_m}{15} = \frac{1 \times 10,000}{15} = 666.7 \Omega$$

Thus we are left with choice of potentiometers having a resistance of : 100 Ω , 200 Ω , 300 Ω , 400 Ω , 500 Ω and 600 Ω . The potentiometer with the highest resistance gives the highest sensitivity. Therefore, the 600 Ω potentiometer is selected.

With a power dissipation of 5 W, the maximum allowable excitation voltage is :

$$(e_i)_{max} = \sqrt{P R_p} = \sqrt{5 \times 600} = 57.4 \text{ V}$$

The sensitivity of the potentiometer when it is a single turn unit :

$$K = \frac{e_i}{360} = \frac{57.4}{360} = 0.16 \text{ V/degree}$$

Example 25.6. A helipot is provided with 40 turns/mm. The gearing arrangement is such that the motion of the main shaft by one revolution causes 5 revolutions of the potentiometer shaft. Calculate the resolution of the potentiometer.

Solution :

The resolution of the potentiometer without the gearing arrangement $1/400 \text{ mm} = 25 \mu\text{m}$.

With gearing arrangement which causes 5 revolutions of potentiometer shaft with one rotation of main shaft, the resolution $= \frac{25}{5} = 5 \mu\text{m}$.

25.18. Strain Gauges

If a metal conductor is stretched or compressed, its resistance changes on account of the fact that both length and diameter of conductor change. Also there is a change in the value of resistivity of the conductor when it is strained and this property is called piezo resistive effect. Therefore, resistance strain gauges are also known as piezoresistive gauges. The strain gauges are used for measurement of strain and associated stress in experimental stress analysis. Secondly, many other detectors and transducers, notably the load cells, torque meters, diaphragm type pressure gauges, temperature sensors, accelerometers and flow meters, employ strain gauges as secondary transducers.

25.18.1. Theory of Strain Gauges. The change in the value of resistance by straining the gauge may be partly explained by the normal dimensional behaviour of elastic material. If a strip of elastic material is subjected to tension, or in other words positively strained, its longitudinal dimension will increase while there will be a reduction in the lateral dimension. So when a gauge is subjected to a positive strain, its length increases while its area of cross-section decreases. Since the resistance of a conductor is proportional to its length and inversely proportional to its area of cross-section, the resistance of the gauge increases with positive strain. The change in the value of resistance of strained conductor is more than what can be accounted for an increase in resistance due to dimensional changes.

The extra change in the value of resistance is attributed to a change in the value of resistivity of a conductor when strained. This property, as described earlier, is known as piezoresistive effect.

Let us consider a strain gauge made of circular wire. The wire has the dimensions : length = L , area = A , diameter = D before being strained. The material of the wire has a resistivity ρ .

\therefore Resistance of unstrained gauge $R = \rho L/A$.

Let a tensile stress s be applied to the wire. This produces a positive strain causing the length to increase and area to decrease. Thus when the wire is strained there are changes in its dimensions. Let ΔL = change in length, ΔA = change in area, ΔD = change in diameter and ΔR = change in resistance.

In order to find how ΔR depends upon the material physical quantities, the expression for R is differentiated with respect to stress s . Thus we get :

$$\frac{dR}{ds} = \frac{\rho}{A} \frac{\partial L}{\partial s} - \frac{\rho L}{A^2} \frac{\partial A}{\partial s} + \frac{L}{A} \frac{\partial \rho}{\partial s} \quad \dots(25'20)$$

Dividing Eqn. 25'20 throughout by resistance $R = \rho L/A$, we have

$$\frac{1}{R} \frac{dR}{ds} = \frac{1}{L} \frac{\partial L}{\partial s} - \frac{1}{A} \frac{\partial A}{\partial s} + \frac{1}{\rho} \frac{\partial \rho}{\partial s} \quad \dots(25'21)$$

It is evident from Eqn. 25'21, that the per unit change in resistance is due to :

(i) per unit change in length = $\Delta L/L$. (ii) per unit change in area = $\Delta A/A$.

Area $A = \frac{\pi}{4} D^2 \quad \therefore \frac{\partial A}{\partial s} = 2 \cdot \frac{\pi}{4} D \cdot \frac{\partial D}{\partial s} \quad \dots(25'22)$

or $\frac{1}{A} \frac{dA}{ds} = \frac{(2\pi/4)D}{(\pi/4)D^2} \frac{\partial D}{\partial s} = \frac{2}{D} \frac{\partial D}{\partial s} \quad \dots(25'23)$

\therefore Eqn. 25'21 can be written as :

$$\frac{1}{R} \frac{dR}{ds} = \frac{1}{L} \frac{\partial L}{\partial s} - \frac{2}{D} \frac{\partial D}{\partial s} + \frac{1}{\rho} \frac{\partial \rho}{\partial s} \quad \dots(25'24)$$

Now, Poisson's ratio $\nu = \frac{\text{lateral strain}}{\text{longitudinal strain}} = - \frac{\partial D/D}{\partial L/L} \quad \dots(25'25)$

or $\partial D/D = -\nu \times \partial L/L$

$\therefore \frac{1}{R} \frac{dR}{ds} = \frac{1}{L} \frac{\partial L}{\partial s} + \nu \frac{2}{L} \frac{\partial L}{\partial s} + \frac{1}{\rho} \frac{\partial \rho}{\partial s} \quad \dots(25'26)$

For small variations, the above relationship can be written as :

$$\frac{\Delta R}{R} = \frac{\Delta L}{L} + 2\nu \frac{\Delta L}{L} + \frac{\Delta \rho}{\rho} \quad \dots(25'27)$$

The gauge factor is defined as the ratio of per unit change in resistance to per unit change in length.

Gauge factor $G_f = \frac{\Delta R/R}{\Delta L/L} \quad \dots(25'28)$

or $\frac{\Delta R}{R} = G_f \frac{\Delta L}{L} = G_f \times \epsilon \quad \dots(25'29)$

where $\epsilon = \text{strain} = \frac{\Delta L}{L}$

The gauge factor can be written as :

$$G_f = \frac{\Delta R/R}{\Delta L/L} = 1 + 2\nu + \frac{\Delta \rho/\rho}{\Delta L/L} = 1 + 2\nu + \frac{\Delta \rho/\rho}{\epsilon} \quad \dots(25'30)$$

The strain is usually expressed in terms of microstrain. 1 microstrain = 1 $\mu\text{m/m}$.

If the change in the value of resistivity of a material when strained is neglected, the gauge factor is :

$$G_f = 1 + 2\nu \quad \dots(25'31)$$

Eqn. 25.31 is valid only when Piezoresistive Effect i.e. change in resistivity due to strain is almost negligible.

The Poisson's ratio for all metals is between 0 and 0.5. This gives a gauge factor of approximately, 2. The common value for Poisson's ratio for wires is 0.3. This gives a value of 1.6 for wire wound strain gauges.

Table 25.3 gives the value of gauge factors for the various materials.

TABLE 25.3
Gauge Factors

Material	Gauge Factor	Material	Gauge Factor
Nickel	-12.1	Platinum	+4.8
Manganin	+0.47	Carbon	+20
Nichrome	+2.0	Doped } Crystals }	100-5000
Constantan	+2.1		
Soft iron	+4.2		

Example 25.7. A resistance wire strain gauge uses a soft iron wire of small diameter. The gauge factor is +4.2. Neglecting the piezoresistive effects, calculate the Poisson's ratio.

Solution. The gauge factor is given by Eqn. 25.30, $G_f = 1 + 2\nu + \frac{\Delta \rho / \rho}{\epsilon}$

If piezoresistive effect is neglected, the gauge factor is given by Eqn. 25.32 as : $G_f = 1 + 2\nu$

\therefore Poisson's ratio $\nu = \frac{G_f - 1}{2} = \frac{4.2 - 1}{2} = 1.6$.

Example 25.8. A compressive force is applied to a structural member. The strain is 5 micro-strain. Two separate strain gauges are attached to the structural member, one is a nickel wire strain gauge having a gauge factor of -12.1 and the other is nichrome wire strain gauge having a gauge factor of 2. Calculate the value of resistance of the gauges after they are strained. The resistance of strain gauges before being strained is 120 Ω .

Solution. According to our convention, the tensile strain taken as positive while the compressive strain is taken as negative. Therefore, strain $\epsilon = -5 \times 10^{-6}$ (1 micro strain = 1 $\mu\text{m/m}$)

Now $\Delta R/R = G_f \epsilon$ (See Eqn. 25.29)

\therefore Change in value of resistance of nickel wire strain gauge : $\Delta R = G_f \epsilon \times R$
 $= (-12.1) \times (-5 \times 10^{-6}) \times 120 = 7.26 \times 10^{-3} \Omega = 7.26 \text{ m}\Omega$.

Thus there is an increase of 7.26 m Ω in the value of resistance.

For nichrome, the change in the value of resistance is :

$\Delta R = (2) \times (-5 \times 10^{-6}) \times 120 = -1.2 \times 10^{-3} \Omega = -1.2 \text{ m}\Omega$.

Thus with compressive strain, the value of resistance gauge shows a decrease of 1.2 m Ω in the value of resistance.

25.19 Types of Strain Gauges

There are three types of strain gauges :

- (i) Wire wound strain gauges,
- (ii) Foil type strain gauges,
- and (iii) Semiconductor strain gauges.

25.20. Resistance Wire Strain Gauges

Resistance wire strain gauges are used in two forms. These two forms are :

- (i) Unbonded, and (ii) Bonded.

25.20.1. Unbonded Strain Gauges. An unbonded strain gauge is shown in Fig. 25.15. This gauge consists of a wire stretched between two points in an insulating medium such as air. The diameter of the wire is about $25\ \mu\text{m}$ and can be strained depending on the way a spring flexure element moves.

In Fig. 25.15 the flexure element is connected via a rod to a diaphragm which is used for pressure measurement. The wires are tensioned to avoid buckling when they experience compressive forces.

The unbonded strain gauges are usually connected in a bridge circuit. With no load applied to the strain gauges, the bridge is balanced.

When an external load is applied, the resistance of strain gauges change causing an unbalance of the bridge circuit which results in an output voltage. This voltage is proportional to the strain. A displacement of the order of $50\ \mu\text{m}$ may be detected with these strain gauges.

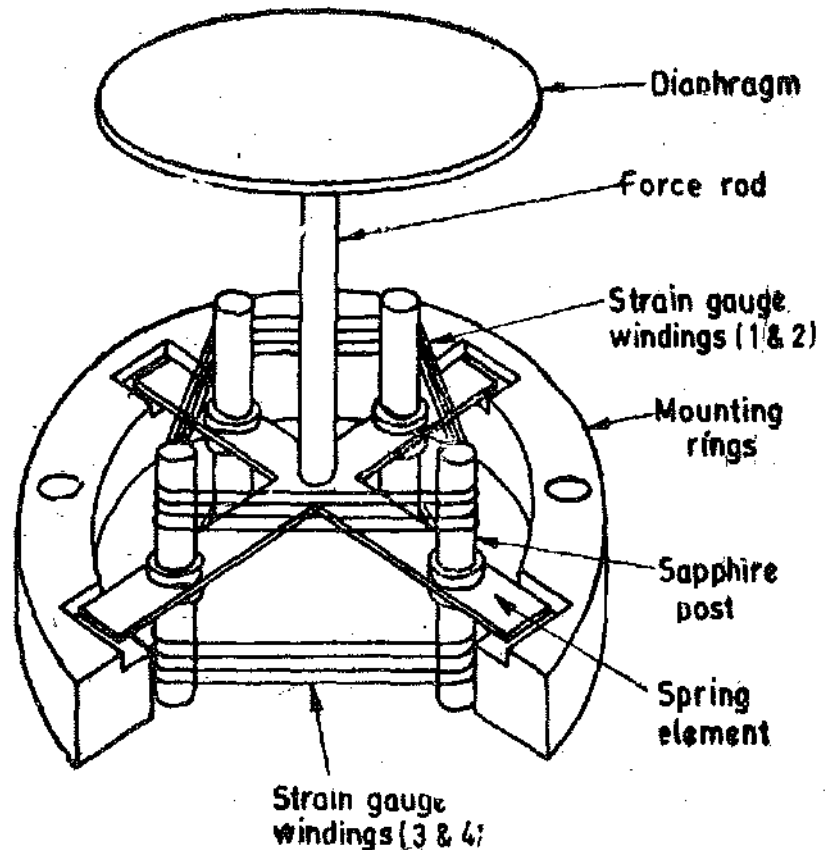

Fig. 25.15. Unbonded resistance wire strain gauge.

25.20.2. Bonded Resistance Wire Strain Gauges. A resistance wire strain gauge consists of a grid of fine resistance wire of about $25\ \mu\text{m}$ ($0.025\ \text{mm}$) in diameter or less. The grid of fine wire is cemented to a carrier (base) which may be thin sheet of paper or to a very thin bakelite sheet or to a sheet of teflon. The wire is covered on top with a sheet of thin material so that it is not damaged mechanically. The spreading of the wire permits a uniform distribution of stress. The carrier is bonded with an adhesive material to the structure under study. This permits a good transfer of strain from carrier to wires. The most commonly used form of resistance wire strain gauges is shown in Fig. 25.16.

The size of the strain gauges varies with application. They can be as small as $3\ \text{mm}$ by $3\ \text{mm}$ square. Usually they are larger, but seldom more than $2.5\ \text{mm}$ long and $12.5\ \text{mm}$ wide.

For excellent and reproducible results it is desirable that the resistance wire strain gauges should have the following characteristics :

(i) The strain gauge should have a high value of gauge factor G_f . A high value of gauge factor indicates a large change in resistance for a particular strain resulting in high sensitivity.

(ii) The resistance of the strain gauge should be as high as possible since this minimizes the effects of undesirable variations of resistance in the measurement circuit. Although undesirable, but necessary, are the resistance of connecting leads and terminals, etc. Typical resistances of strain gauges are $120\ \Omega$, $350\ \Omega$ and $1000\ \Omega$. Although a high resistance value of strain gauges is desirable from the point of view of swamping out the effects of variations of resistance in other parts of the bridge circuit in which they are invariably used but it results in lower sensitivity.

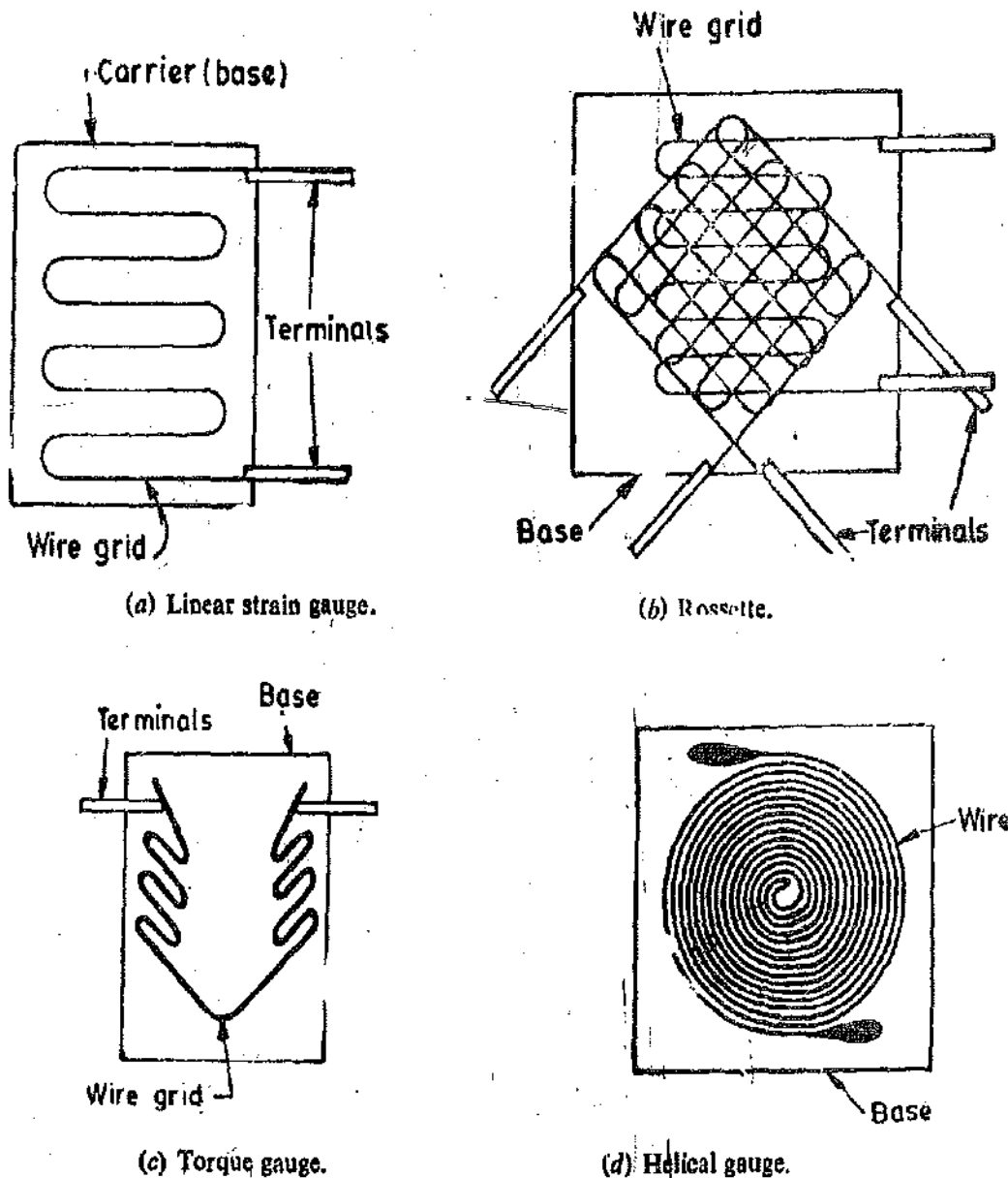

Fig. 25'16. Resistance wire strain gauge.

Thus in order to get high sensitivity higher bridge voltages have to be used. The bridge voltage is limited by the maximum current carrying capacity of the wires which is typically 30 mA.

(iii) The strain gauges should have a low resistance temperature co-efficient. This is essential to minimize errors on account of temperature variations which affect the accuracy of measurements.

(iv) The strain gauge should not have any hysteresis effects in its response.

(v) In order to maintain constancy of calibration over the entire range of the strain gauge, it should have linear characteristics *i.e.*, the variations in resistance should be a linear function of the strain.

(vi) The strain gauges are frequently used for dynamic measurements and hence their frequency response should be good. The linearity should be maintained within accuracy limits over the entire frequency range.

The desirable characteristics of resistance wire strain gauges are listed above but no single material is able to satisfy all the properties since they are, many a times, conflicting in nature. A number of metals and their alloys have been used in making resistance wire strain gauges. Some popular

metals and alloys used for construction of resistance wire strain gauges are listed in Table 25.4 along with their properties.

TABLE 25.4
Materials for Strain Gauges

Material	Composition	Gauge Factor	Resistivity $\Omega \text{ m}$	Resistance-Temperature Co-efficient $\Omega/\Omega-^{\circ}\text{C}$	Upper Temperature $^{\circ}\text{C}$
Nichrome	Ni : 80% Cr : 20%	2.5	100×10^{-8}	0.1×10^{-3}	1200
Constantan	Ni : 45% Cu : 55%	2.1	48×10^{-8}	$\pm 0.02 \times 10^{-3}$	400
Isoelastic	Ni : 36% Cr : 8% Mo : 0.5% etc.	3.6	105×10^{-8}	0.175×10^{-3}	1200
Nickel	—	-12	6.5×10^{-8}	6.8×10^{-3}	—
Platinum	—	4.8	10×10^{-8}	4.0×10^{-3}	—

Base (Carrier) Materials. Several types of base or carrier materials are used to support the wires. Impregnated paper is used for room temperature applications. The range of some of the other materials are :

Epoxy : -200°C to 150°C

Bakelite impregnated cellulose or glass fibre filled materials :

up to 200°C for continuous operation, and up to 300°C for limited operation.

Adhesives. The adhesives act as bonding materials. Like other bonding operations, successful strain gauge bonding depends upon careful surface preparation and use of the correct bonding agent. In order that the strain be faithfully transferred on to the strain gauge, the bond has to be formed between the surface to be strained and the plastic backing material on which the gauge is mounted. It is important that the adhesive should be suited to this backing; numerous materials are used for backings which require different adhesive materials. It is usually desirable that the adhesive material should be of quick drying type and also be insensitive to moisture in order to have good adherence.

Ethylcellulose cement, nitrocellulose cement, bakelite cement and epoxy cement are some of the commonly used adhesive materials. The temperature range up to which they can be used is usually below 175°C .

Leads. The leads should be of such materials which have low and stable resistivity and also a low resistance temperature co-efficient.

25.20.3. Foil Strain Gauges. This class of strain gauges is only an extension of the resistance wire strain gauges. The strain is sensed with the help of metal foils as against metal wires as in wire strain gauges. The metals and alloys used for the foil are listed in Table 25.4. Foil gauges have a much greater dissipation capacity as compared with wire wound gauges on account of their greater surface area for the same volume. For this reason they can be used for higher operating temperature range. Also the large surface area of foil gauges leads to better bonding. The bonded foil gauges are extensively used. Early strain gauges were made from fine wire, but these gauges have now been virtually superseded by foil gauges.

A typical foil gauge is shown in Fig. 25.17. Foil type strain gauges have similar characteristics

to those of wire wound strain gauges and their gauge factors are typically the same as that of wire wound strain gauges. The advantage of foil type strain gauges is that they can be fabricated economically on a mass scale. The techniques used for fabrication are similar to electronic micro-circuitry *i.e.*, thick and/or thin-film technology commonly used for hybrid integrated circuits (ICs). This means that the foil strain gauges can be fabricated in any shape. The resistance film formed is typically 0.02 mm thick. The resistance elements are vacuum coated with ceramic film and are deposited on a plastic backing which provides insulation, and facilitates perfect bonding. In some cases the backing is strippable vinyl material that can be peeled off so as to cement the film directly on to the test unit with ceramic adhesive. The resistance value of foil gauges which are commercially available is between 50 and 1000 Ω .

Some commonly used forms of foil gauges are shown in Fig. 25.18.

It is interesting to carry out simple calculations to find out what effect an applied stress has on the resistance of a metal strain gauge. Hook's law gives the relationship between stress and strain for linear stress strain curve (*i.e.*, for elastic limits) in terms of modulus of elasticity of material under tension. Hook's law may be written as :

$$\text{Strain } \epsilon = s/E$$

...(25.36)

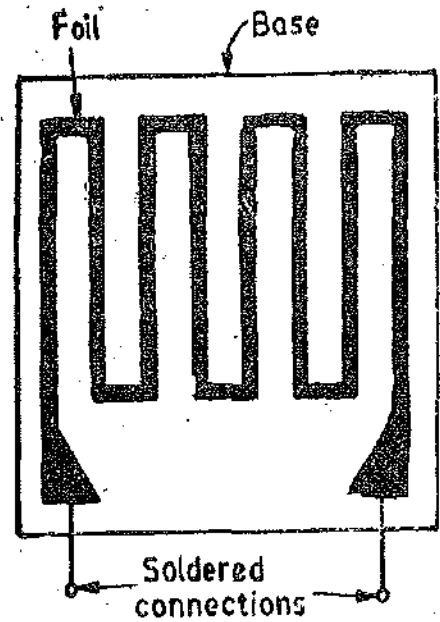

Fig. 2.417. Foil type strain gauge.

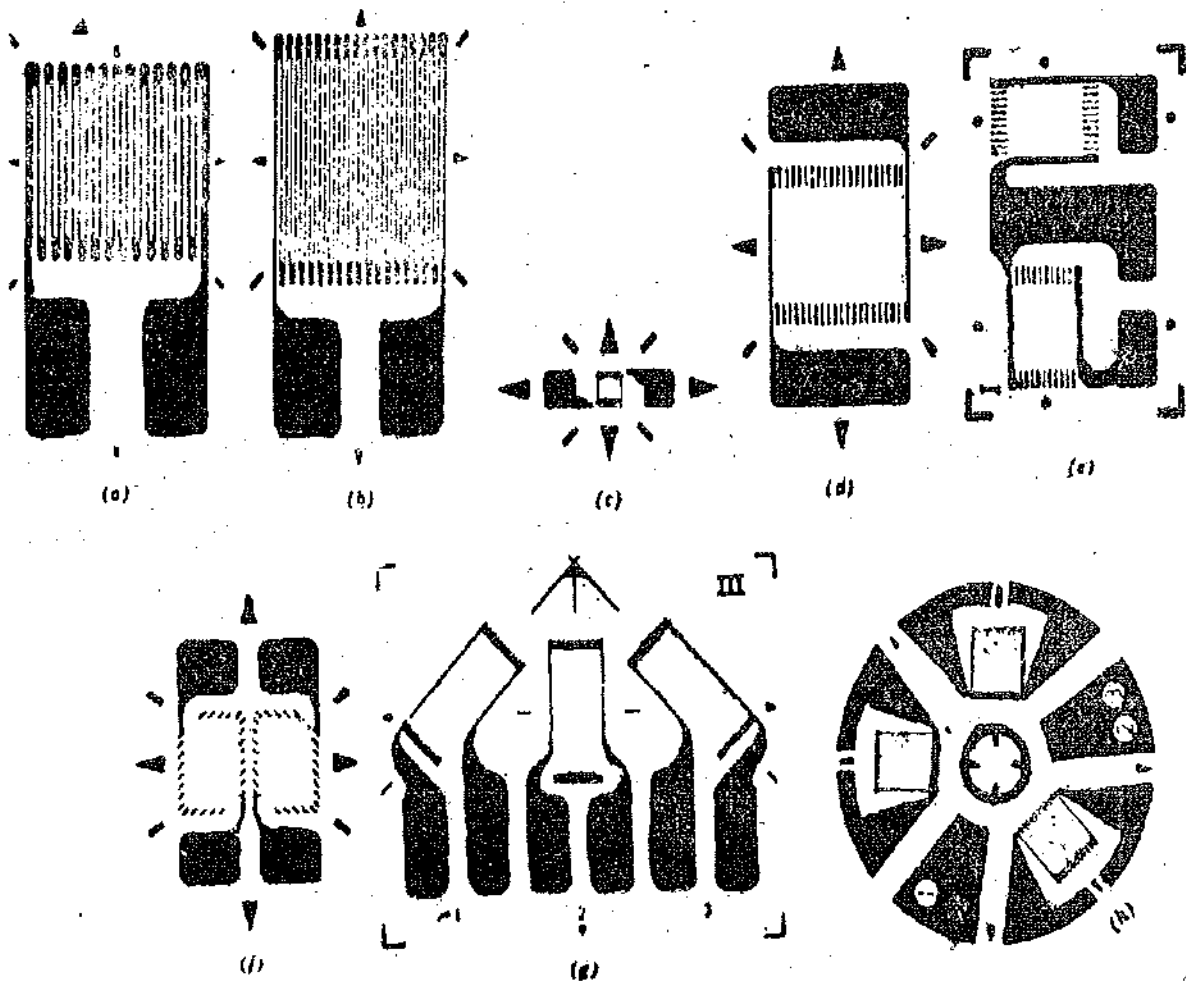
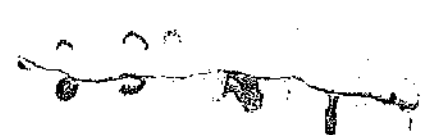

Fig. 25.18. Strain Gauges and Rosettes.



where E = modulus of elasticity.

The change in the value of resistance is quite small as is amply clear from the following example :

Example 25.9. A resistance wire strain gauge with a gauge factor of 2 is bonded to a steel structural member subjected to a stress of 100 MN/m^2 . The modulus of elasticity of steel is 200 GN/m^2 . Calculate the percentage change in the value of the gauge resistance due to the applied stress. Comment upon the results.

$$\text{Solution. Strain } \epsilon = \frac{s}{E} = \frac{100 \times 10^6}{200 \times 10^9} = 500 \times 10^{-6} \text{ (500 microstrain).}$$

$$\text{We have : } \frac{\Delta R}{R} = G_f \epsilon = 2 \times 500 \times 10^{-6} = 0.001 = 0.1\%$$

\therefore The change in resistance is only 0.1%.

Comments. The above example illustrates that a very heavy stress of 100 MN/m^2 results in resistance change of only 0.1 per cent, which is by all means a very small change. This may present difficulties in measurement. Lower stresses produce still lower changes in resistance which may not be perceptible at all or the methods required to detect those changes may have to be highly accurate. To overcome this difficulty we must use strain gauges which have a high gauge factor and thus produce large changes in resistance when strained. These changes are easy to detect and measure with good degree of accuracy.

Example 25.10. A single strain gauge having resistance of 120Ω is mounted on a steel cantilever beam at a distance of 0.15 m from the free end. An unknown force F applied at the free end produces a deflection of 12.7 mm of the free end. The change in gauge resistance is found to be 0.152Ω . The beam is 0.25 m long with a width of 20 mm and a depth of 3 mm . The Young's modulus for steel is 200 GN/m^2 . Calculate the gauge factor.

$$\text{Solution. Moment of inertia of beam, } I = 1/12 (bd^3) = 1/12 \times 0.02 \times (0.003)^3 = 45 \times 10^{-12} \text{ m}^4.$$

$$\text{Deflection } x = \frac{Fl^3}{3EI}$$

$$\therefore \text{ Force } F = \frac{3EIx}{l^3} = \frac{3 \times 200 \times 10^9 \times 45 \times 10^{-12} \times 12.7 \times 10^{-3}}{(0.25)^3} = 22 \text{ N.}$$

$$\text{Bending moment at } 0.15 \text{ m from free end } M = Fx = 22 \times 0.15 = 3.3 \text{ Nm.}$$

$$\text{Stress at } 0.15 \text{ m from free end } s = \frac{M}{I} \cdot \frac{l}{2} = \frac{3.3}{45 \times 10^{-12}} \times \frac{0.003}{2} = 110 \text{ MN/m}^2.$$

$$\text{Strain } \epsilon = \frac{\Delta L}{L} = \frac{s}{E} = \frac{110 \times 10^6}{200 \times 10^9} = 0.55 \times 10^{-3}$$

$$\therefore \text{ Gauge factor} = \frac{\Delta R/R}{\Delta L/L} = \frac{0.152/120}{0.55 \times 10^{-3}} = 23.$$

25.20.4. Semi-conductor Strain Gauges. It has been explained above in order to have a high sensitivity, a high value of gauge factor is desirable. A high gauge factor means a relatively higher change in resistance which can be easily measured with a good degree of accuracy.

Semiconductor strain gauges are used where a very high gauge factor and a small envelope are required. The resistance of the semi-conductors changes with change in applied strain. Unlike in the case of metallic gauges where the change in resistance is mainly due to change in dimensions when strained, the semi-conductor strain gauges depend for their action upon piezo-resistive effect (i.e., the change in the value of the resistance due to change in resistivity).

Semi-conducting materials such as silicon and germanium are used as resistive materials for semi-conductor strain gauges. A typical strain gauge consists of a strain sensitive crystal material and leads that are sandwiched in a protective matrix. The production of these gauges employs conventional semi-conductor technology using semi-conducting wafers or filaments which have a thickness of 0.05 mm and bonding them on a suitable insulating substrates, such as teflon. Gold leads are generally employed for making the contacts. Some of the typical semi-conductor strain gauges are shown in Fig 25.19. These strain gauges can be fabricated along with integrated circuit (IC) operational amplifiers which can act as pressure sensitive transducers.

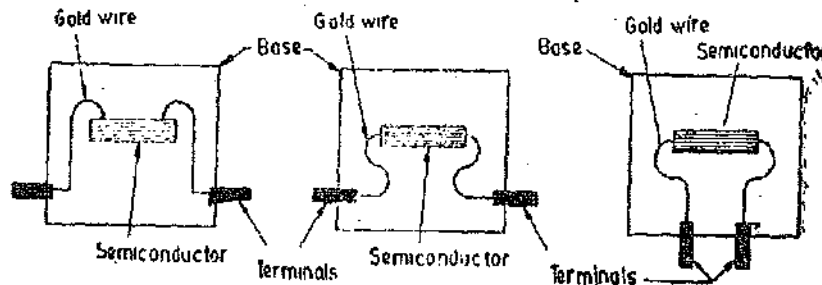

Fig. 25.19. Semi-conductor strain gauge.

Advantages : (i) Semi conductor strain gauges have the advantage that they have a high gauge factor of about ± 130 . This allows measurement of very small strains of the order of 0.01 microstrain.

(ii) Hysteresis characteristics of semi-conductor strain gauges are excellent. Some units maintain it to less than 0.05%.

(iii) Fatigue life is in excess of 10×10^8 operations and the frequency response is upto 10^{12} Hz.

(iv) Semi-conductor strain gauges can be very small ranging in length from 0.7 to 7 mm. They are very useful for measurement of local strains.

Disadvantages : (i) The major and serious disadvantage of semi-conductor strain gauges is that they are very sensitive to changes in temperature.

(ii) Linearity of the semi-conductor strain gauges is poor. The equation for the fractional change in resistance is :

$$\Delta R/R = As + B \epsilon^{-4} \text{ where } A \text{ and } B \text{ are constants.}$$

This gauge is rather non-linear at comparatively high strain levels. The gauge factor varies with strain. For example if the gauge factor is 130 at 0.2 per cent strain, then it is 112 at 0.4 per cent strain. The characteristics can be made linear by proper doping.

(iii) Semi-conductor strain gauges are more expensive and difficult to attach to the object under study.

25.21. Resistance Thermometers

The resistance of a conductor changes when its temperature is changed. This property is utilized for measurement of temperature.

The variation of resistance R with temperature T can be represented by the following relationship for most of the metals as :

$$R = R_0(1 + \alpha_1 T + \alpha_2 T^2 + \dots + \alpha_n T^n + \dots) \quad \dots(25.32)$$

where R_0 = resistance at temperature $T=0$ and $\alpha_1, \alpha_2, \alpha_3, \dots, \alpha_n$ are constants.

The resistance thermometer uses the change in electrical resistance of conductor to determine

the temperature. The requirements of a conductor material to be used in these thermometers are :

- (i) the change in resistance of material per unit change in temperature should be as large as possible.
- and (ii) the resistance of the materials should have a continuous and stable relationship with temperature.

The characteristics of various materials used for resistance thermometers are plotted in Fig. 25.20.

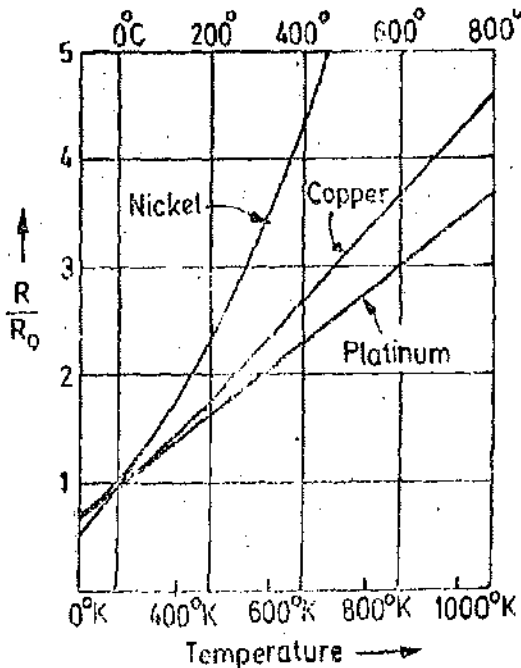

Fig. 25.20. Characteristics of materials used for resistance thermometers.

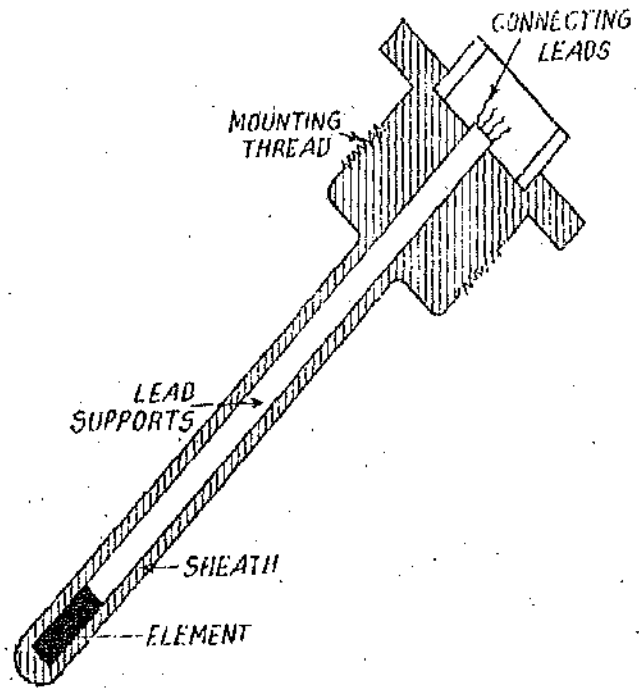

Fig. 25.21. Industrial platinum resistance thermometer

Metals commonly used for resistance thermometers are listed in Table 25.5 along with their salient properties.

TABLE 25.5
Metals Used for Resistance Thermometers

Metal	Resistance temperature co-efficient °C (per cent)	Temperature range °C		Melting point °C
		Min.	Max.	
Platinum	0.39	-260	1100	1773
Copper	0.39	0	180	1083
Nickel	0.62	-220	300	1455
Tungsten	0.45	-200	1000	3370

Platinum, nickel and copper are the most commonly used metals to measure temperature. The value of α_1 for platinum between 0–100°C is about 0.004/°C. In fact the resistivity of platinum tends to increase less rapidly at higher temperatures than for other metals, and therefore it is most commonly used material for resistance thermometers. Platinum is commercially available in pure form and has a stability over a high range of temperature as shown in Table 25.5.

An examination of the resistance versus temperature curves of Fig. 25.22 show that the curves are nearly linear. In fact, when only short temperature spans are considered, the linearity is even more evident. This fact is employed to develop approximate analytical equations of resistance versus temperature of a particular metal.

25.21.1. Linear Approximation.

A linear approximation means that we may develop an equation for a straight line which approximates the resistance versus temperature curve over a specified span. Fig 25.22 shows a curve for variation of resistance with temperature θ .

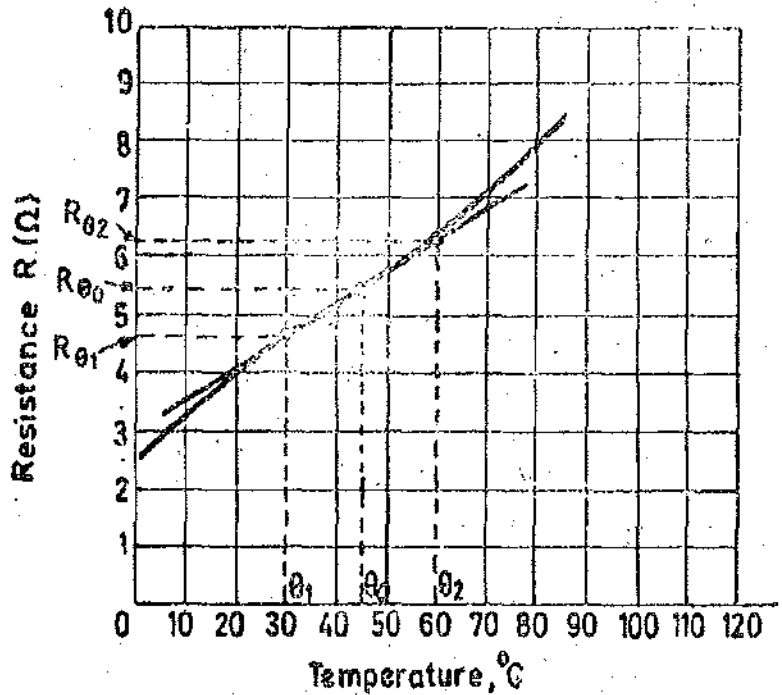

Fig. 25.22. A straight line representing an approximate relationship between resistance R and temperature θ .

Hence a straight line has been drawn between the points of the curve which represent temperatures θ_1 and θ_2 as shown, with θ_0 representing the midpoint temperature. The equation of this straight line is the linear approximation to the curve over the span θ_1 to θ_2 . The equation of the straight line written as :

$$R_\theta = R_{\theta_0} (1 + \alpha_{\theta_0} \Delta \theta) \quad \text{with } \theta_1 < \theta_0 < \theta_2. \quad \dots(25.33)$$

where

R_{θ_0} = approximate resistance at temperature $\theta_0^\circ\text{C}$;

R_{θ_0} = approximate resistance at temperature $\theta_0^\circ\text{C}$; Ω

$\Delta \theta = \theta - \theta_0$ = change in temperature ; $^\circ\text{C}$,

α_{θ_0} = resistance temperature co-efficient at temperature $\theta_0^\circ\text{C}$; $^\circ\text{C}$.

The reason for using α_{θ_0} as the fractional slope of the resistance: temperature curve is that this same constant can be used for conductors having of the same material with different dimensions. The value of α_{θ_0} can be found from the value of resistance and temperature as shown in Fig. 25.22.

In general :

$$\alpha_{\theta_0} = \frac{1}{R_{\theta_0}} \times (\text{slope at } \theta_0) = \frac{1}{R_{\theta_0}} \left[\frac{R_{\theta_2} - R_{\theta_1}}{\theta_2 - \theta_1} \right] \quad \dots(25.34)$$

Example 25.11. Find the linear approximation for resistance between 30°C to 60°C using the resistance-temperature curve given in Fig. 25.22.

Solution. We have : $\theta_1 = 30^\circ\text{C}$ and $\theta_2 = 60^\circ\text{C}$.

$$\therefore \theta_0 = \frac{\theta_1 + \theta_2}{2} = \frac{30 + 60}{2} = 45^\circ\text{C}.$$

From Fig. 25.22, we have :

Resistance at 30°C, $R_{\theta_1} = 4.8 \Omega$. Resistance at 45°C, $R_{\theta_0} = 5.5 \Omega$.

and Resistance at 60°C, $R_{\theta_2} = 6.2 \Omega$.

$$\text{From Eqn. 25.34, } \alpha_{\theta_0} = \frac{1}{R_{\theta_0}} \times \frac{R_{\theta_2} - R_{\theta_1}}{\theta_2 - \theta_1} = \frac{1}{5.5} \times \frac{6.2 - 4.8}{60 - 30} = 0.0085 \Omega/\Omega - ^\circ\text{C}$$

$$\text{Hence the linear approximation is : } R_{\theta} = 5.5[1 + 0.0085(\theta - 45)]$$

where θ is the unknown temperature in $^\circ\text{C}$.

25.21.2. Quadratic Approximation. A quadratic approximation to the resistance-temperature curve is a more accurate representation of the resistance-temperature curve over a limited range of temperature. The quadratic approximation relationship includes both a linear term as in Eqn. 25.33 and in addition has a term which varies as the square of the temperature. This approximation is written as :

$$R_{\theta} = R_{\theta_0} [1 + \alpha_1 \Delta\theta + \alpha_2 (\Delta\theta)^2] \quad \dots(25.35)$$

α_1 = linear fractional change in resistance ; $\Omega/\Omega - ^\circ\text{C}$,

and α_2 = quadratic fractional change in resistance ; $\Omega/\Omega - (^{\circ}\text{C})^2$.

Values of α_1 and α_2 are found from tables or from graphs as indicated in example given below by using values of resistance and temperature at three different points. Two equations are formed and values of α_1 and α_2 can be found from these equations.

Example 25.12. Use the values of resistance *versus* temperature given in the table below to find the linear and quadratic approximations of resistance between 100°C and 130°C about a mean temperature of 115°C.

Temperature $^\circ\text{C}$	90	95	100	105	110	115	120	125	130
Resistance Ω	562.66	568.03	573.40	578.77	584.13	589.48	594.84	600.18	605.52

Solution.

1. **Linear Approximation** $\theta_1 = 100^\circ\text{C}$, $\theta_2 = 130^\circ\text{C}$ and $\theta_0 = 115^\circ\text{C}$.

Resistance at 100°C, $R_{\theta_1} = 573.40 \Omega$. Resistance at 115°C, $R_{\theta_0} = 589.48 \Omega$.

Resistance at 130°C, $R_{\theta_2} = 605.52 \Omega$.

From Eqn. 25.34,

$$\alpha_1 = \frac{1}{R_{\theta_0}} \times \frac{R_{\theta_2} - R_{\theta_1}}{\theta_2 - \theta_1} = \frac{1}{589.48} \times \frac{(605.52 - 573.40)}{(130 - 100)} = 0.00182 \Omega/\Omega - ^\circ\text{C}.$$

\therefore The linear approximation is $R_{\theta} = 589.48[1 + 0.00182(\theta - 115)]$

2 Quadratic Approximation

The resistance at any temperature θ is given by Eqn. 25.35/

$$R_{\theta} = R_{\theta_0} [1 + \alpha_1 \Delta\theta + \alpha_2 (\Delta\theta)^2]$$

We can find the quadratic terms in Eqn. 25'35 by forming two equations using two points about 115°C.

Therefore, $R_{\theta} = 589.48 \Omega$, $\theta_0 = 115^\circ\text{C}$.

Now using 100°C and 130°C as the two points, we get two equations :

$$573.40 = 589.48[1 + \alpha_1(100 - 115) + \alpha_2(100 - 115)^2]$$

and $605.52 = 589.48[1 + \alpha_1(130 - 115) + \alpha_2(130 - 115)^2]$

Solving the above equations we get :

$$\alpha_1 = 1.59 \times 10^{-3} \Omega/\Omega - ^\circ\text{C} \quad \text{and} \quad \alpha_2 = 15.098 \times 10^{-6} \Omega/\Omega - (^{\circ}\text{C})^2.$$

Hence, $R_{\theta} = 589.48[1 + 1.59 \times 10^{-3}(\theta - 115) - 15.09 \times 10^{-6}(\theta - 115)^2]$.

Example 25'13. (a) A Platinum resistance thermometer has a resistance of 100 Ω at 25°C. Find its resistance at 65°C. The resistance temperature co-efficient of Platinum is 0.00392 $\Omega/\Omega - ^\circ\text{C}$.

(b) If the thermometer has a resistance of 150 Ω , calculate the value of the temperature.

Solution. (a) Using the linear approximation, the value of resistance at any temperature is :

$$R_{\theta} = R_{\theta_0}[1 + \alpha_{\theta_0} \Delta\theta]$$

\therefore Resistance at 65°C. $R_{65} = 100[1 + 0.00392(65 - 25)] = 115.68 \Omega$.

(b) Suppose θ is the unknown temperature.

$\therefore 150 = 100[1 + 0.00392(\theta - 25)]$ or $\theta = 152.55 \Omega$.

Example 25'14. A 10 Ω copper resistor at 20°C is to be used to indicate the temperature of bearings of a machine. What resistance should not be exceeded if the maximum bearing temperature is not to exceed 150°C. The resistance temperature co-efficient of copper is 0.00393 $\Omega/\Omega - ^\circ\text{C}$ at 20°C.

Solution. The value of the resistance in case the temperature is not to exceed 150°C can be calculated as under :

$$R_{150} = 10[1 + 0.00393(150 - 20)] = 15.11 \Omega.$$

Example 25'15. A temperature alarm unit with a time constant of 120 s is subjected to a sudden rise of temperature of 50°C because of a fire. If an increase of 30°C is required to actuate the alarm, what will be the delay in signalling the sudden temperature increase.

Solution. Assume the thermometer to be first order system, the variation of indicated temperature θ to a step input temperature θ_0 is given by Eqn. 24'37.

$$\theta = \theta_0 \left(1 - e^{-t/\tau}\right) \quad \text{or} \quad 30 = 50 \left(1 - e^{-t/120}\right)$$

$\therefore t = 110$ second.

Hence the alarm will be delayed by 110 second

25'22. Thermistors

Thermistors is a contraction of term "Thermal Resistors". They are essentially semi-conductors which behave as resistors with a high negative temperature co-efficient of resistance. In some cases the resistance of a thermistor at room temperature may decrease as much as 5 per cent for each 1°C rise in temperature. This high sensitivity to temperature changes make the thermistors extremely useful for precision temperature measurements, control and compensation. Thermistors are widely used in such applications especially in the temperature range of -60°C to +15°C. The resistance of thermistors ranges from 0.5 Ω to 0.75 M Ω .

25'22.1. Construction. Thermistors are composed of sintered mixture of metallic oxides such as manganese, nickel, cobalt, copper, iron and uranium. They are available in variety of sizes and

shapes. The thermistors may be in the form of beads, rods or discs. Commercial forms are shown in Fig. 25.23.

A thermistor in the form of a bead is smallest in size and the bead may have a diameter of 0.015 mm to 1.25 mm. Beads may be sealed in the tips of solid glass rods to form probes which may be easier to mount than the beads. Glass probes have a diameter of about 2.5 mm and a length which varies from 6 mm to 50 mm. Discs are made by pressing material under high pressure into cylindrical flat shapes with diameters ranging from 2.5 mm to 25 mm.

25.22. Resistance Temperature Characteristics of Thermistors. The mathematical expression for the relationship between the resistance of a thermistor and absolute temperature of thermistor is

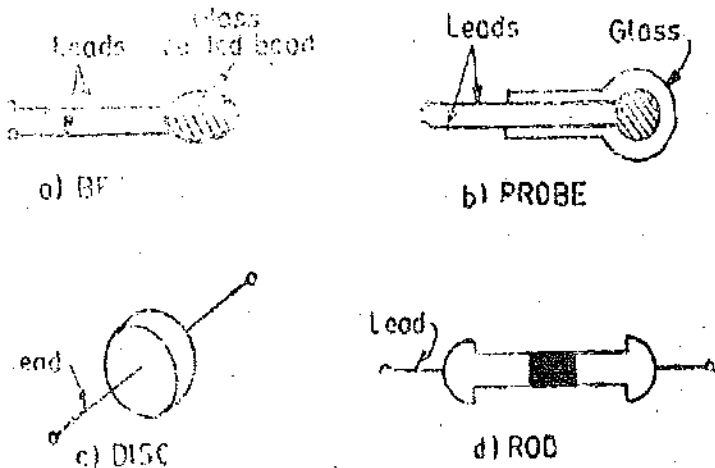

Fig. 25.23. Thermistors.

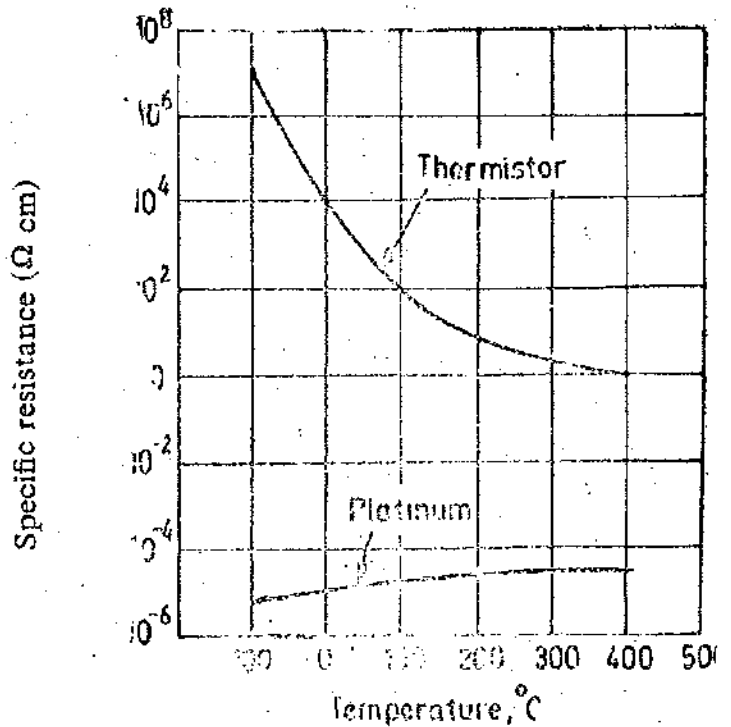

Fig. 25.24. Resistance-temperature characteristics of a typical thermistor and platinum.

$$R_{T_1} = R_{T_2} \exp. \left[\beta \left(\frac{1}{T_1} - \frac{1}{T_2} \right) \right] \quad \dots(25.36)$$

where

R_{T_1} = resistance of the thermistor at absolute temperature T_1 ; K,

R_{T_2} = resistance of the thermistor at absolute temperature T_2 ; K,

and

β = a constant depending upon the material of thermistor, typically 3500 to 4500 K.

The resistance temperature characteristics of a typical thermistor are given in Fig. 25.24. The resistance temperature characteristics of Fig. 25.24 show that a thermistor has a very high negative temperature co-efficient of resistance, making it an ideal temperature transducer.

Fig. 25.24 also shows the resistance-temperature characteristics of platinum which is a commonly used material for resistance thermometers. Let us compare the characteristics of the two materials. Between -100°C and 400°C , the thermistor changes its resistivity from 10^7 to $1.0 \Omega \text{ cm}$, a factor of 10^7 , while platinum changes its resistivity by a factor of about 10 within the same temperature range. This explains the high sensitivity of thermistors for measurement of temperature.

The characteristics of thermistors are no doubt non-linear but a linear approximation of the resistance-temperature curve can be obtained over a small range of temperatures. Thus for a limited range of temperature, the resistance of a thermistor varies as given by Eqn. 25.33.

$$R_\theta = R_{\theta_0} [1 + \alpha_{\theta_0} \Delta \theta]$$

A thermistor exhibits a negative resistance temperature co-efficient which is typically $0.05 \Omega/\Omega-^{\circ}\text{C}$.

In place of linear approximation, an approximate logarithmic relationship may be used for resistance-temperature relationship for a thermistor.

$$\text{The relationship is : } R_T = aR_0 e^{b/T} \quad \dots(25.37)$$

where R_0 = resistance at ice point ; Ω , R_T = resistance at temperature T ; K, and a, b are constants.

25.22.3. Applications of Thermistors. The applications of thermistors are :

(i) The major application of thermistors is in the field of measurement of temperature. The thermistor's large change of resistance with temperature provides good accuracy and resolution.

A typical thermistor with a resistance of 200Ω at 25°C and a resistance temperature co-efficient of $0.039 \Omega/\Omega -^{\circ}\text{C}$ shows a resistance change of $78 \Omega/^{\circ}\text{C}$.

Thermistors can also be used for :

(ii) Temperature compensation in complex electronic equipment, magnetic amplifiers and instrumentation equipment. This is because thermistors possess a negative resistance temperature coefficient and therefore they can be used as compensators in electrical circuits, as in operation of computer circuits which are affected by temperature changes. An increased stability is obtained by using thermistors as compensating devices

(iii) Measurement of power at high frequencies. (iv) Measurement of thermal conductivity.

(v) Measurement of level, flow and pressure of liquids.

(vi) Measurement of composition of gases. (vii) Vacuum measurements.

(viii) Providing time delay.

Example 25.16. A thermistor has a resistance temperature co-efficient of -5% over a temperature range of 25°C to 50°C . If the resistance of the thermistor is 100Ω at 25°C , what is the resistance at 35°C .

Solution. Resistance at a temperature of 35°C is :

$$R_{35} = 100 [1 - 0.05(35 - 25)] = 50^{\circ}\Omega$$

Example 25.17. A thermistor has a resistance of 3980Ω at the ice point (0°C) and 794Ω at 50°C . The resistance-temperature relationship is given by $R_T = a R_0 e^{b/T}$. Calculate the constants a and b .

Calculate the range of resistance to be measured in case the temperature varies from 40°C to 100°C .

Solution. The resistance at ice point $R_0 = 3980 \Omega$.

Absolute temperature at ice point = 273 K .

$$\therefore 3980 = a \times 3980 \times e^{b/273} \quad \text{or} \quad 1 = a e^{b/273} \quad \dots(i)$$

Resistance at 50°C is $R_T = 794 \Omega$.

Absolute temperature corresponding to 50°C is $T = 273 + 50 = 323 \text{ K}$.

$$\text{Hence,} \quad 794 = a \times 3980 e^{b/323} = 3980 a e^{b/323} \quad \dots(ii)$$

Solving (i) and (ii), we have $a = 30 \times 10^{-6}$ and $b = 2845$.

Absolute temperature at $40^{\circ}\text{C} = 273 + 40 = 313 \text{ K}$

$$\therefore \text{Resistance at } 40^{\circ}\text{C} = 30 \times 10^{-6} \times 3980 \times e^{2845/313} = 1060 \Omega.$$

Absolute temperature at $100^{\circ}\text{C} = 273 + 100 = 373 \text{ K}$

Resistance at $100^{\circ}\text{C} = 30 \times 10^{-6} \times 3980 e^{2845/313} = 245 \Omega$.

Thus the range of resistance is 1060Ω to 245Ω .

Example 25.18. An automatic temperature control arrangement for an electric oven is shown in Fig. 25.25. The thermistor has a resistance of 2000Ω at 70°C . A potentiometer is used for obtaining balance conditions. The temperature of oven changes and therefore the rheostat has to be set at 1800°C to obtain balanced conditions. Using the linear approximation for the resistance temperature curve obtain the change in the value of resistance. The resistance temperature coefficient can be assumed as $-0.05 \Omega/\Omega-^{\circ}\text{C}$.

Solution. Using linear approximation (Eqn. 25.33), we have :

$$1800 = 2000[1 - 0.05(\theta - 70)] \quad \text{or } \theta = 72^{\circ}\text{C}.$$

Example 25.19. A thermistor has a resistance of $10 \text{ k}\Omega$ at 25°C . The resistance temperature coefficient is $-0.05 \Omega/\Omega-^{\circ}\text{C}$. A Wien's bridge oscillator uses two identical thermistors in the frequency determining part of the bridge. The value of capacitance used in the bridge is 500 pF .

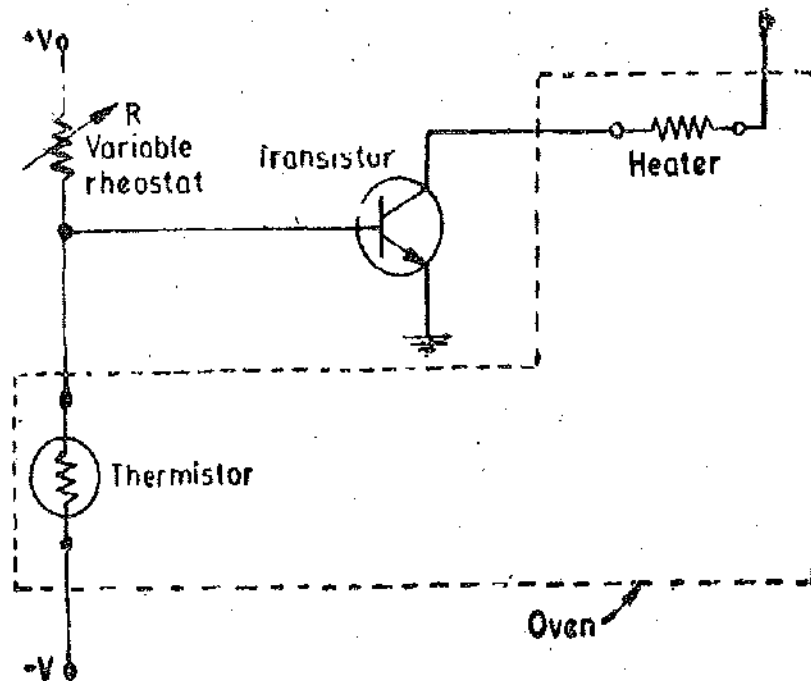

Fig. 25.25. Temperature control system using thermistors.

Calculate the value of frequency of oscillations for (i) 20°C , (ii) 25°C and (iii) 30°C . The frequency of oscillations is $f = 1/2\pi RC \text{ Hz}$ where R and C are resistance and capacitance respectively.

Solution. (i) Resistance of thermistor at $20^{\circ}\text{C} = 10,000[1 - 0.05(20 - 25)] = 12,500 \Omega$.

$$\therefore \text{Frequency of oscillations } f = \frac{1}{2\pi RC} = \frac{1}{2\pi \times 12500 \times 500 \times 10^{-12}} \text{ Hz} = 25.46 \text{ kHz}.$$

(ii) Resistance of thermistor at $25^{\circ}\text{C} = 10,000 \Omega$

$$\therefore \text{Frequency of oscillations} = \frac{1}{2\pi \times 10 \times 10^3 \times 500 \times 10^{-12}} \text{ Hz} = 31.83 \text{ kHz}.$$

(iii) Resistance of thermistor at $30^{\circ}\text{C} = 10,000[1 - 0.05(30 - 25)] = 7500 \Omega$.

$$\therefore \text{Frequency of oscillations} = \frac{1}{2\pi \times 7500 \times 500 \times 10^{-12}} \text{ Hz} = 42.44 \text{ kHz}.$$

Hence the variation of the frequency of the oscillator is from 25 kHz to 42 kHz approximately.

25.23. Variable Inductance Type Transducers

The variable inductance type of transducers work, generally, upon one of the following three principles :

- (i) Variation of self-inductance, (ii) Variation of mutual inductance.
- and (iii) Production of eddy current.

25.24. Inductive Transducers Working on Principle of Variation of Self Inductance :

The self inductance of a coil $L = N^2/R$ henry.

where N = number of turns, and R = reluctance of the magnetic circuit

The reluctance of the magnetic circuit is $R = l/\mu A$.

\therefore Inductance $L = N^2 \mu(A/l) = N^2 \mu G$...(25.38)

where μ = effective permeability of the medium in and around the coil,

$G = A/l$ = geometric for n factor, A = area of cross-section of magnetic path ; m^2 ,

and l = length of magnetic path ; m

Inductive transducers are mainly used for measurement of displacement. The displacement to be measured is arranged to cause variation of any of three variables in Eqn. 25.38 and thus alter the self-inductance L by ΔL .

The variation in inductance may be caused by change in number of turns, variation in geometric configuration or by change in permeability of magnetic material or magnetic circuit.

Let us consider the case of a general inductive transducer. The inductive transducer has N turns and a reluctance R . When a current i is passed through it, the flux is $\Phi = Ni/R$.

Differentiating the expression for Φ with respect to time, we get,

$$\frac{d\Phi}{dt} = \frac{N}{R} \frac{di}{dt} - \frac{Ni}{R^2} \frac{dR}{dt}$$
...(25.39)

In practice we can generally arrange that one term of the right hand side in the expression for $d\Phi/dt$ predominates over the other. For example, if the current varies very rapidly, perhaps a million times per second, the first term on right hand side of Eqn. 25.39 becomes very large as compared with the second term. The relationship thus reduces to :

$$\frac{d\Phi}{dt} = \frac{N}{R} \frac{di}{dt}$$
...(25.40)

Emf induced $e = N \frac{d\Phi}{dt} = \frac{N^2}{R} \frac{di}{dt}$...(25.41)

Also self-inductance $L = \frac{e}{di/dt} = \frac{N^2}{R}$...(25.42)

The output from an inductive transducer can be had in the form of either a change in voltage or a change in inductance.

25.24.1. Transducers working on principle of change self-inductance with number of turns.
 The output may be caused by change in number of turns. Fig. 25.26 shows the transducers used for measurement of linear and angular displacements respectively. Fig. 25.26 (a) shows an air cored coil for measurement of linear displacement while Fig. 25.26 (b) an iron cored coil used for measurement of angular displacement.

The output if it is in the form of inductance is :

$L \propto N^2$, $\propto (\text{displacement})^2$ in case the windings are uniformly wound.

25'24'2. Transducers working on the principle of change in self-inductance with change in geometric configuration. Figs. 25'27 (a) and (b) show inductive transducers which are used for measurement of linear and angular displacements respectively and which work on the principle of variation of inductance with geometric configuration (i.e., variation of $G = A/l$). It should be noted that 'd' is the displacement.

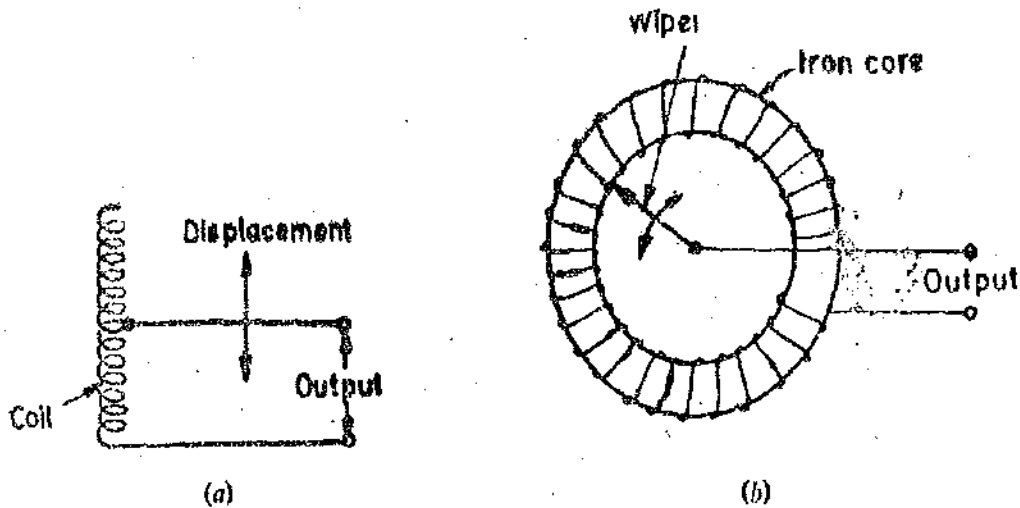

Fig. 25'26. Inductive transducer wherein self-inductance is changed on account of change of number of turns.

Fig. 25'27 (a) shows an air cored coil divided into two parts. The displacement 'd' causes the movement of one part of the coil with respect to the other changing the geometric configuration of the coil which results in change in self-inductance of the coil.

Fig. 25'27 (b) shows an arrangement where there are two parts of the coil mounted on iron cores. One part is stationary while the other is movable. The angular displacement to be measured changes the position of the movable part of the coil. This changes the self-inductance of the coil.

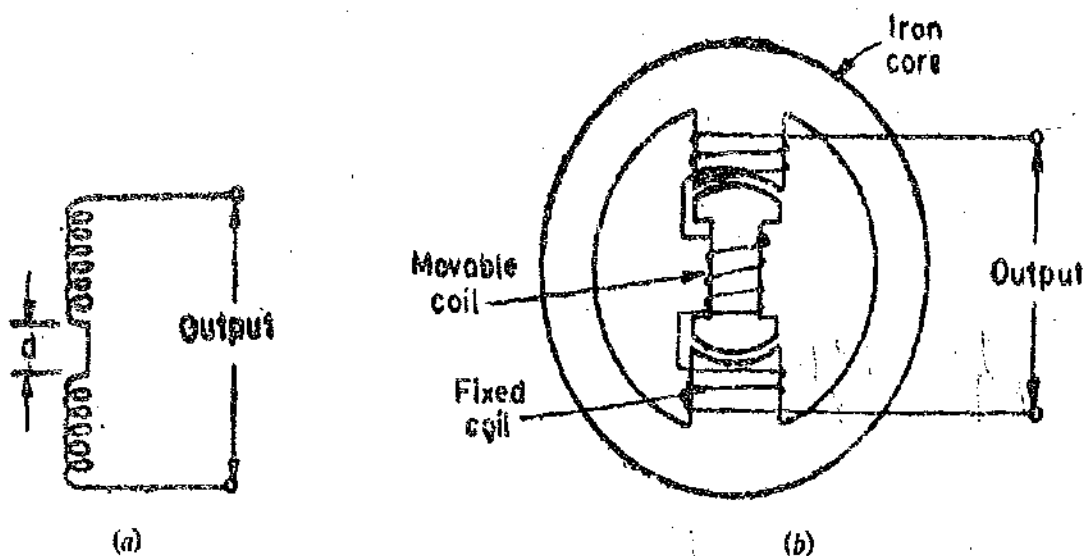

Fig. 25'27: Inductive transducers for measurement of displacement using the effect of change of geometric configuration for change in self-inductance.

25'24'3. Transducers working on the principle of change in self-inductance with change in permeability. An inductive transducer which works on the principle of variation of permeability to cause change of self inductance is shown in Fig. 25'28. The iron core is surrounded by a winding.

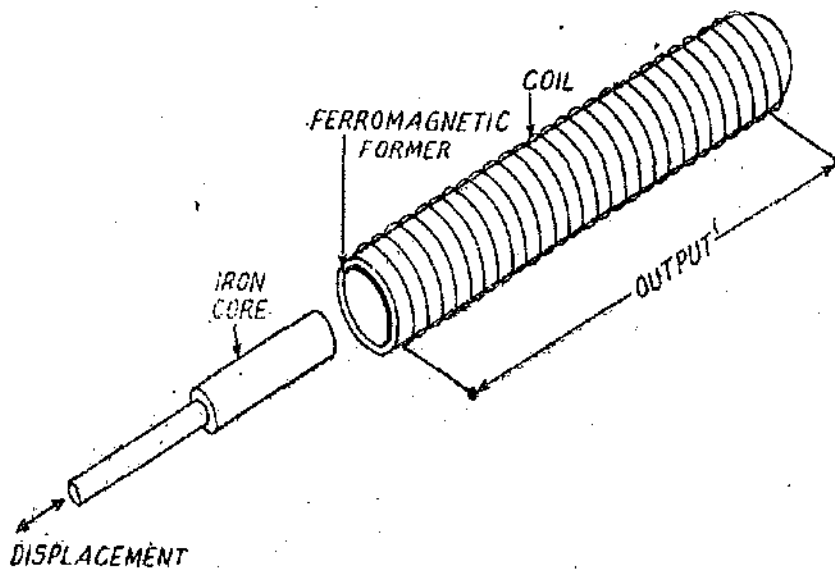

Fig. 25'28. Inductive transducer for measurement of displacement using the effect of change of inductance due to change in permeability.

If the iron core is inside the winding its inductance is high but when the iron core is moved out of the winding, the permeability of the flux path decreases resulting in reduction of self-inductance of the coil. This transducer can conveniently be used for measurement of displacement.

25'24.4. Variable Reluctance Type Transducers The variable reluctance type of transducers may be considered as forerunners of the modern Linear Variable Differential Transformer (L.V.D.T) which is explained in Art. 25'28. A variable reluctance type of transducer consists of a coil which is wound on a ferromagnetic core. The displacement, which is the measurand, is applied to a ferromagnetic target as shown in Fig. 25'29. The target does not make a physical contact with a core on which the coil is mounted. The core and the target are separated by an air gap.

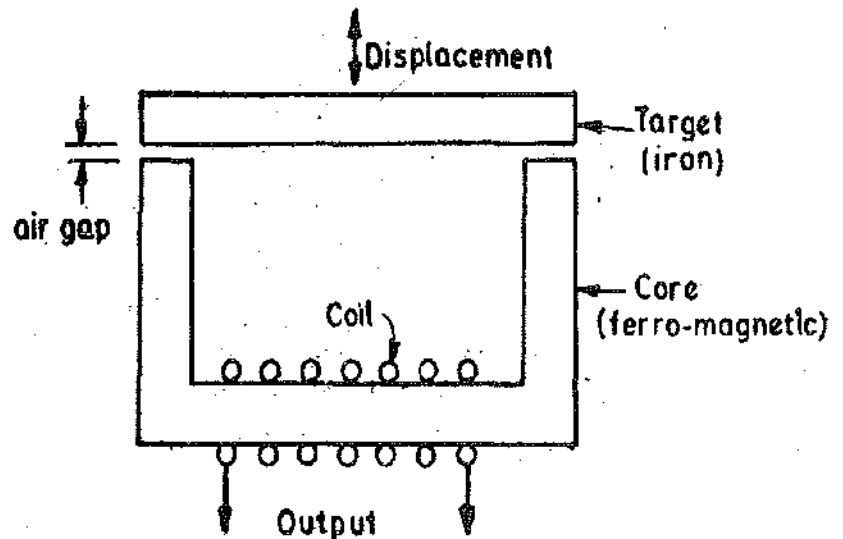

Fig. 25'29. Variable reluctance type transducer.

The inductance of the coil depends upon the reluctance of the magnetic circuit. The self-inductance of the coil is given by :
$$L = \frac{N^2}{R_i + 2R_g}$$

where R_i = reluctance of iron parts, and R_g = reluctance of air gap.

The reluctance of iron parts is negligible as compared with reluctance of air parts.

$$\therefore L = \frac{N^2}{R_g}$$

Reluctance of air part of magnetic circuit $R_g = \frac{l_g}{\mu_0 A_g}$

where l_g = length of air gap, and A_g = air of flux path through air.

$\therefore R_g \propto l_g$ as μ_0 and A_g are constant

Hence $L \propto 1/l_g$

Therefore self-inductance of the coil is inversely proportional to the length of air gap. When the target is near to the core, the length of the air gap is small and so the self-inductance of the coil is large, while when the target is away from the core, the length of air gap is large and hence reluctance is larger resulting in small values of self-inductance. Therefore, we conclude that the inductance of the coil is a function of the distance of the target from the core i.e. length of the air gap. Since it is the displacement which is changing the length of air gap, the self-inductance is a function of the displacement. It should be clear that the self-inductance of the coil is a non-linear function of the displacement. The self-inductance of the coil can be measured with the help of any inductance bridges as explained in chapter 16.

25'24.5. Differential Output. Normally the change in self-inductance ΔL for inductive transducers working on the principle of change of self-inductance ΔL (or ΔM , which is the change in mutual inductance for transducers working on the principle of change of mutual inductance M) is adequate for detection for subsequent stages of instrumentation system. However, if the succeeding stages of instrumentation respond to ΔL or ΔM , rather than to $L + \Delta L$ or $M + \Delta M$, the sensitivity and accuracy will be much higher. The transducers can be designed to provide two outputs one of which is an increase of inductance (self or mutual) and the other is a decrease in inductance. The succeeding stages of instrumentation system measure the difference between these outputs. This is known as the differential output. The advantages of differential output are :

- (i) The sensitivity and accuracy are increased.
- (ii) The output is less effected by external magnetic fields.
- (iii) The effective variations due to temperature changes are reduced.
- (iv) The effects of change in supply voltage and frequency are reduced.

The differential arrangement consists of a coil which is divided into two parts (inductive transducers using self-inductance as a variable use one coil while those using mutual inductance as variable use multiple coils).

In response to a physical signal, which is normally a displacement, the inductance of one part increases from L to $L + \Delta L$ while that of the other part decreases from L to $L - \Delta L$. The change is measured as the difference of the two resulting in an output of $2\Delta L$ instead ΔL when only a single winding is used. This increases the sensitivity and also eliminates errors.

Inductive transducers using change of number of turns to cause change in self-inductance are shown in Fig. 25'30. Fig. 25'30 (a) shows arrangement of measurement of linear displacement which uses an air cored coil while arrangement of Fig. 25'30 (b) is used for measurement of angular displacement using an iron cored coil.

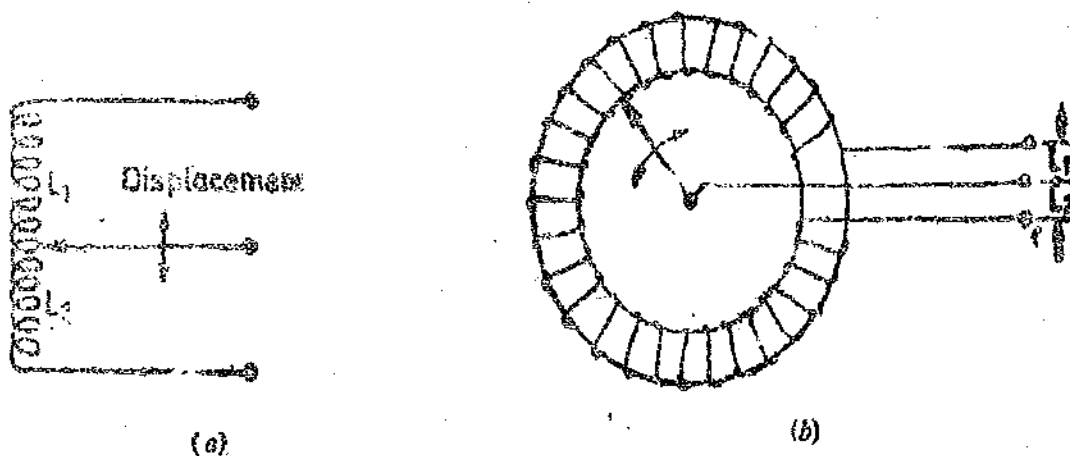

Fig. 25'30. Inductive transducers giving differential output working on the principle of change of self-inductance with change of number of turns.

Fig. 25'31 shows an inductance transducer which works on the principle of change of self-inductance of two coils with change in reluctance of the path of the magnetic circuit. The target as well as the cores on which the coils are mounted are made up of iron.

25.25. Inductive Transducers Working on Principle of Variation of Mutual Inductance

Inductive transducers working on the principle of variation of mutual inductance use multiple coils.

The mutual inductance between the coils can be varied by variation of self-inductances or the co-efficient of coupling. However, the mutual inductance can be converted into a self-inductance by

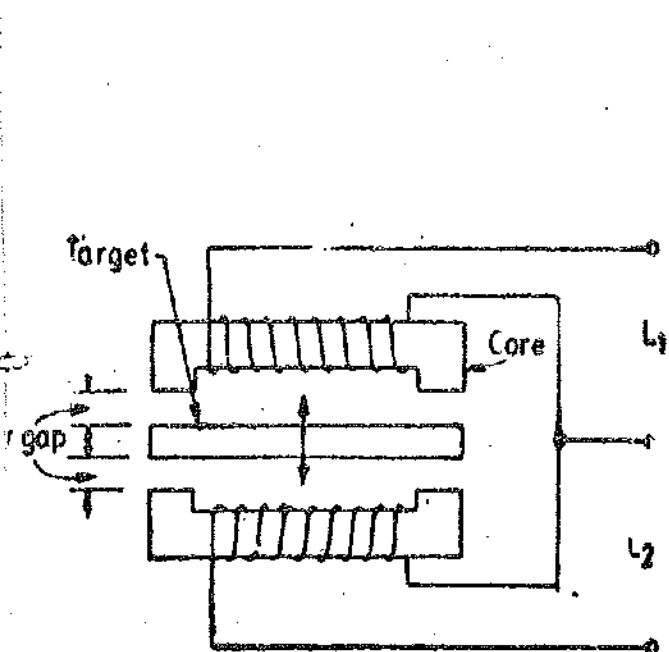

Fig. 25.31. Inductive transducer giving a differential output. The output is change of self-inductance due to change of reluctance.

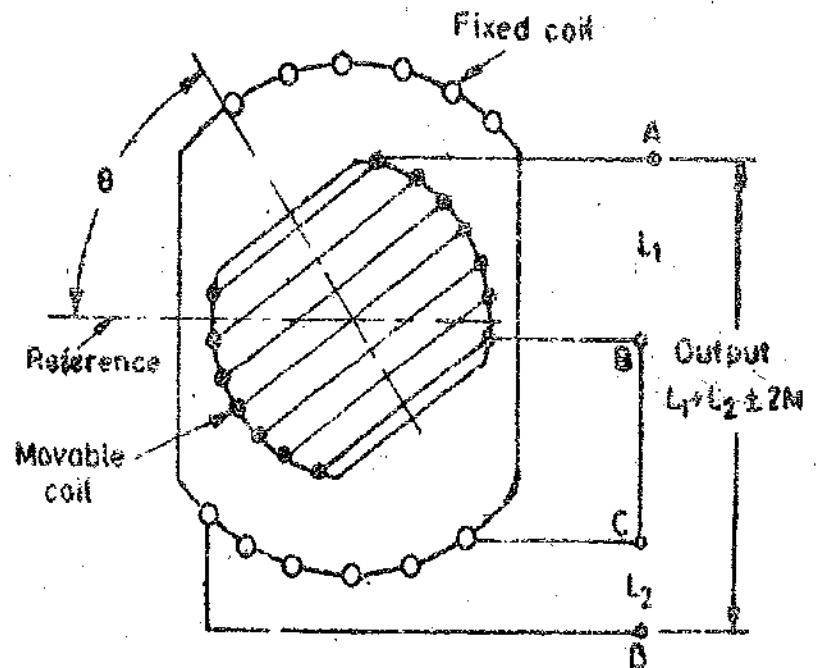

Fig. 25.32. Inductive transducer working on principle of variation of mutual inductance with angular displacement.

connecting the coils in series. The self-inductance of such an arrangement varies between $L_1 + L_2 - 2M$ to $L_1 + L_2 + 2M$. Fig. 25.32 shows one such arrangement. There are two air cored coils. One coil is fixed and the other is made to rotate by the input angular displacement. The self-inductance of the coils is constant but the mutual inductance between the two coils varies on account of variation of angle θ . The co-efficient of coupling is proportional to $\cos \theta$. When the axes

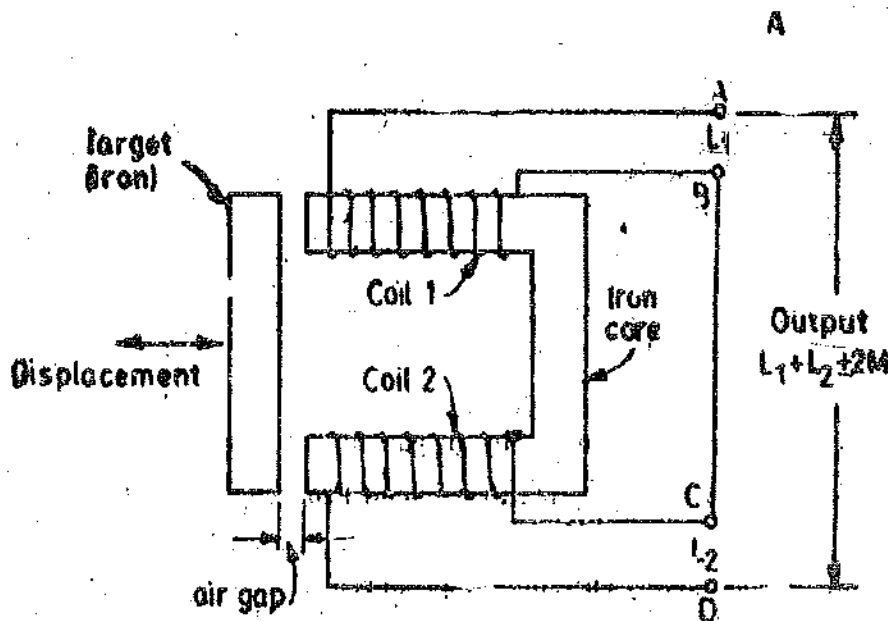

Fig. 25.33. Inductive transducer working on principle of variation of mutual inductance with linear displacement.

of the two coils, coincide, the mutual inductance is maximum. The mutual inductance between the coils at angle θ is : $M_1 = M \cos \theta$, where M = maximum value of mutual inductance ; H.

The inductance between terminals A and B will vary between $L_1 + L_2 - 2M$ to $L_1 + L_2 + 2M$. As is clear from above, the mutual inductance between the two coils changes on account of change in geometric configuration.

Fig. 25'33 shows another arrangement. This arrangement uses two stationary iron cored coils. The linear displacement to be measured is applied to an iron target which changes the length of air gap, which in turn results in change of flux linking the coils causing a change in mutual inductance between the two coils. Here the change in mutual inductance is on account of change in permeability.

A differential arrangement using two air cored coils is shown in Fig. 25'34. There is a fixed coil and a movable coil. The fixed coil is divided into two parts. The movement of the movable coil increases the mutual inductance of one part by ΔM and decreases that of the other part by ΔM .

Both air and iron cored coils have advantages as well as disadvantages.

The following points should be considered while selecting inductive transducers using air or iron cored coils :

(i) Air cored transducers can be used at much higher carrier frequencies. Therefore they are extremely useful for dynamic measurements at high frequencies.

(ii) Iron cored transducers are less likely to cause a stray external magnetic field and also, they, themselves are less affected by external magnetic fields than air cored coils.

(iii) The major disadvantage of iron cored transducers is that they do not exhibit linear characteristics as the value of inductance depends upon the value of the current passing through their coils.

(iv) Iron cored transducers suffer from another disadvantage on account of core losses when subjected to alternating magnetization. Since the hysteresis losses are proportional to frequency and the eddy current losses are proportional to square of the frequency, the iron cored transducers cannot be used at high frequencies. The frequency of supply voltage should not exceed 20 kHz for iron cored transducers to keep the core losses to acceptable values. The dynamic changes to be measured should not have a frequency exceeding 2 kHz. (The carrier frequency is usually 10 times the signal frequency). The supply voltage is also limited to 15 V in order to keep down the core losses.

In practice most of the iron-cored transducers are of variable reluctance type, where the effective permeability is essentially determined by air gaps in the magnetic circuit.

25'26. Inductive Transducers Working on the Principle of Production of Eddy Currents

These inductive transducers work on the principle that if a conducting plate is placed near a coil carrying alternating current, eddy currents are produced in the conducting plate. The conducting plate acts as a short circuited secondary of a transformer. The eddy currents flowing in the plate produce a magnetic field of their own which acts against the magnetic field produced by the coil. This

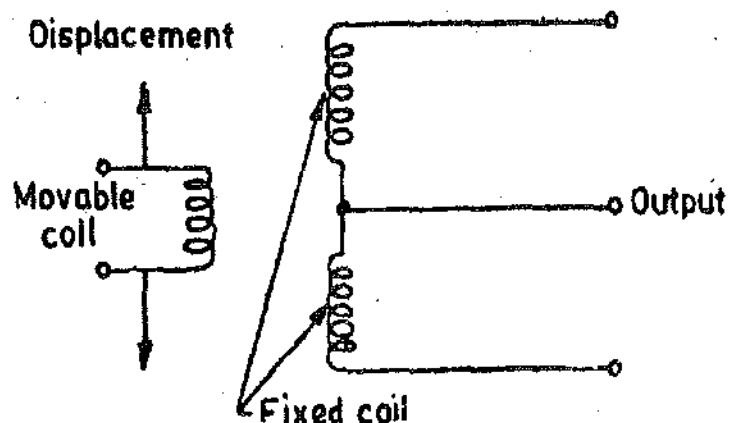

Fig. 25'34. Mutual inductive transducer using a differential arrangement for measurement of linear displacement.

results in reduction of flux and thus the inductance of the coil is reduced. The nearer is the plate to the coil, the higher are the eddy currents and thus higher is the reduction in the inductance of the coil. Thus the inductance of the coil alters with variation of distance between the plate and the coil.

A number of arrangements are possible. The plate may be at right angle to the axis of the coil as shown in Fig. 25'35 (a). The displacement of the plate causes a change in the inductance of

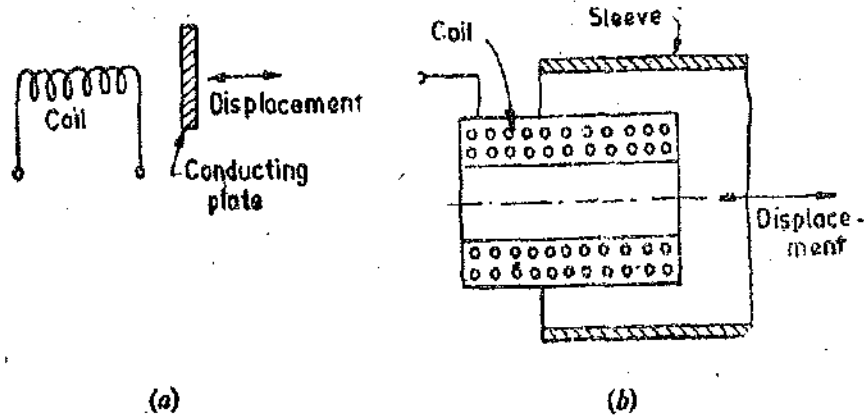

Fig. 25'35. Inductive transducers working on the principle of production of eddy currents.

the coil. Fig. 25'35 (b) shows an arrangement wherein a conducting sleeve runs in parallel and co-axially over a coil. If the short circuited sleeve is away from the coil, the inductance of the coil is high while if the sleeve is covering the coil, its inductance is low. The change in inductance is a measure of displacement.

Fig. 25'36 shows the resume of various types of inductive transducers used for instrumentation purposes.

Change of inductance caused by change of	Single output			Differential or ratio output		
	N: (A)	G: (B)	μ or reluctance (C)	N: (D)	G: (E)	μ or reluctance (F)
Self-induction	Air (1)					
	Iron (2)					
Mutual induction	Air (3)					
	Iron (4)					
Eddy-current						

Fig. 25'36. Inductive transducers.

Example 25.19. In a variable reluctance type proximity inductive transducer the coil has an inductance of $2000 \mu\text{H}$ when the target made of ferromagnetic material is 1 mm away from the core. Calculate the value of inductance when a displacement of 0.02 mm is applied to the target in a direction moving it towards the core. Show that the change in inductance is linearly proportional to the displacement. Neglect the reluctance of the iron parts.

Solution. Inductance with gap length of 1 mm is $L = 2000 \mu\text{H}$.

Length of air gap when a displacement of 0.05 mm is applied to the target
 $= 1.00 - 0.02 = 0.98 \text{ mm}$.

Now inductance is inversely proportional to the length air gap.

\therefore Inductance with gap length of $0.98 \text{ mm} = L + \Delta L = 2000 \times \frac{1}{0.98} \text{ H} = 2040 \mu\text{H}$.

Change in inductance $\Delta L = 2040 - 2000 = 40 \mu\text{H}$.

Ratio $\frac{\Delta L}{L} = \frac{40}{2000} = 0.02$ and Ratio $\frac{\text{displacement}}{\text{normal gap length}} = \frac{0.02}{1.00} = 0.02$

The two ratios are equal and hence the change in inductance is linearly proportional to the displacement. This, however, is true of only very small displacements.

25.27. Linear Variable Differential Transformer (LVDT)

The most widely used inductive transducer to translate the linear motion into electrical signal is the linear variable differential transformer (LVDT). The basic construction of the LVDT is given in Fig 25.37. The transformer consists of a single primary winding P_1 and two secondary windings

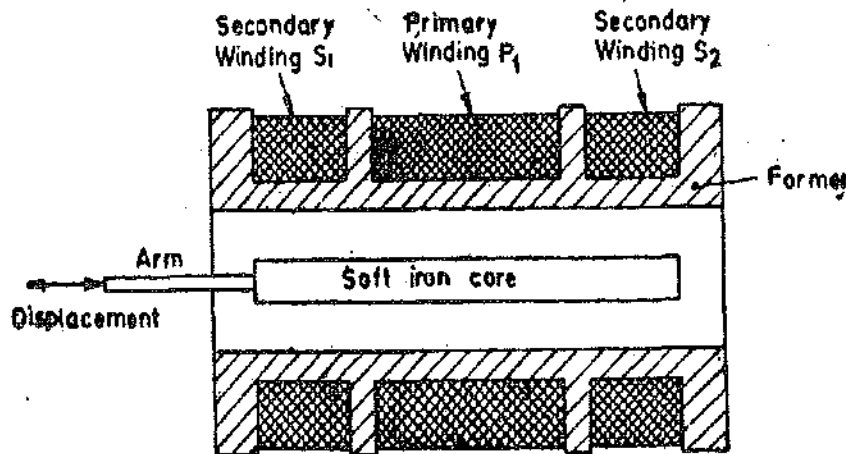

Fig. 25.37. Linear variable differential transformer (LVDT).

S_1 and S_2 wound on a cylindrical former. The secondary windings have equal number of turns and are identically placed on either side of the primary windings. The primary winding is connected to an alternating current source. A movable soft iron core is placed inside the former. The displacement to be measured is applied to an arm attached to the soft iron core. In practice the core is made of nickel iron alloy which is slotted longitudinally to reduce eddy current losses. When the core is in its normal (NULL) position equal voltages are induced in two secondary windings. The frequency of a.c. applied to primary windings may be between 50 Hz to 20 kHz .

The output voltage of secondary, S_1 , is E_{S1} and that of secondary, S_2 , is E_{S2} . In order to convert the outputs from S_1 and S_2 into a single voltage signal, the two secondaries S_1 and S_2 are

connected in series opposition as shown in Fig. 25'38 (b). Thus the output voltage of the transducer is the difference of the two voltages.

Differential output voltage

$$E_0 = E_{s1} - E_{s2} \dots (25'52)$$

When the core is at its normal (NULL) position, the flux linking with both the secondary windings is equal and hence equal emfs are induced in them. Thus at null position $E_{s1} = E_{s2}$. Since the output voltage of the transducer is the difference of the two voltages, the output voltage E_0 is zero at null position.

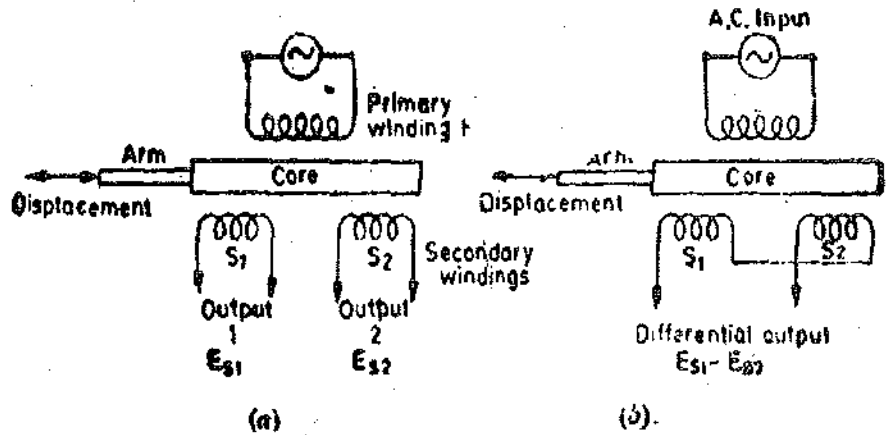

Fig. 25'38. Circuits of an LVDT.

Now if the core is moved to the left of the NULL position, more flux links with winding S_1 and less with winding S_2 . Accordingly output voltage E_{s1} , of the secondary winding S_1 , is more than E_{s2} , the output voltage of secondary winding S_2 . The magnitude of output voltage is, thus, $E_{s1} - E_{s2}$ and the output voltage is in phase with E_{s1} i.e. the output voltage of secondary winding S_1 . Similarly, if the core is moved to the right of the null position, the flux linking with winding S_2 becomes larger than that linking with winding S_1 . This results in E_{s2} becoming larger than E_{s1} . The output voltage in this case is $E_0 = E_{s2} - E_{s1}$ and is in phase with E_{s2} i.e. the output voltage of secondary winding S_2 .

The amount of voltage change in either secondary winding is proportional to the amount of movement of the core. Hence, we have an indication of amount of linear motion. By noting which output voltage is increasing or decreasing, we can determine the direction of motion. In other words any physical displacement of the core causes the voltage of one secondary winding to increase while simultaneously reducing the voltage in the other secondary winding. The difference of the two voltages appears across the output terminals of the transducer and gives a measure of the physical position of core and hence the displacement.

As the core is moved in one direction from the null position, the differential voltage i.e., the difference of the two secondary voltages, will increase while maintaining an in-phase relationship with the voltage from the input source. In the other direction from the null position, the differential voltage will also increase, but will be 180° out of phase with the voltage from the source. By comparing the magnitude and phase of the output (differential) voltage with that of the source, the amount and direction of the movement of the core and hence of displacement may be determined.

The amount of output voltage may be measured to determine the displacement. The output signal may also be applied to a recorder or to a controller that can restore the moving system to its normal position.

The output voltage of an LVDT is a linear function of core displacement within a limited range of motion, say, about 5 mm from the null position. Fig. 25'39 shows the variation of output voltage against displacement.

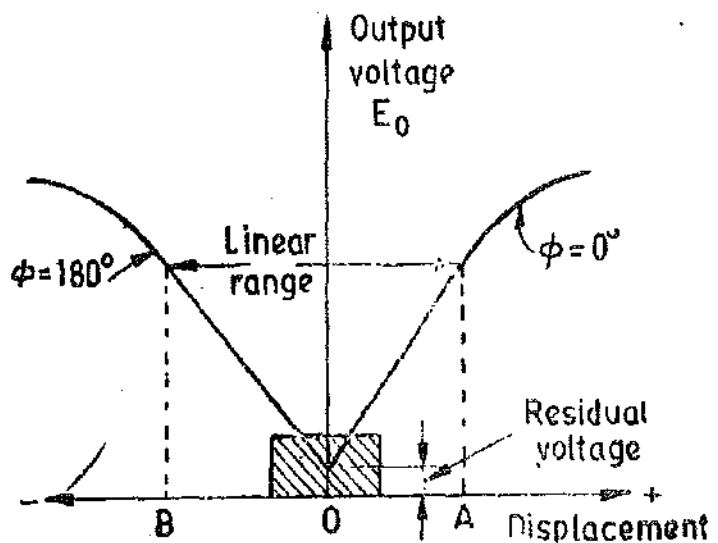

Fig. 25'39. Variation output voltage with linear displacement for an LVDT.

ment for various positions of core. The curve is practically linear for small displacements (upto about 5 mm as mentioned above). Beyond this range of displacement, the curve starts to deviate from a straight line.

Fig. 25'40 shows the core of a LVDT at three different positions. In Fig. 25'40 (b), the core is at 0 which is the central zero or a null position. Therefore $E_{s1} = E_{s2}$ and hence the output $E_0 = 0$.

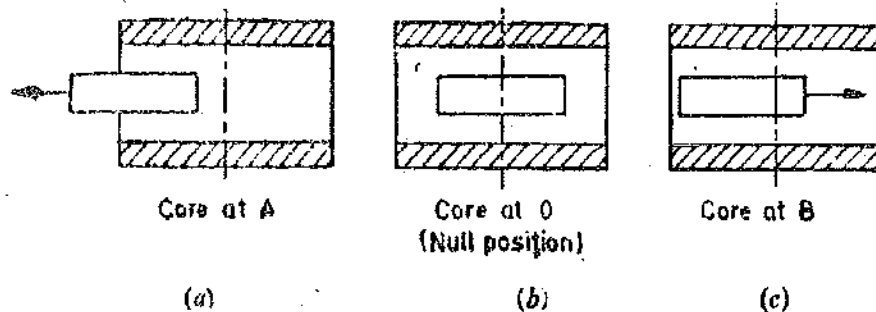

Fig. 25'40. LVDT in various positions.

When the core is moved to the left as in Fig. 25'40 (a) and is at A, E_{s1} is more than E_{s2} and therefore E_0 is +ve. By convention, this movement represents a positive value of E_0 and therefore the phase angle $\phi = 0$. When the core is moved to the right towards B as shown in Fig. 25'40 (c), E_{s2} is greater than E_{s1} and hence E_0 is negative. Therefore, the output voltage is 180° out of the phase with the voltage which is obtained when the core is moved to the left. Thus $\phi = 180^\circ$. The characteristics are linear up to 0--A and 0--B but after that they become non-linear and flatten out as shown in Fig. 25'39.

Ideally the output voltage at the null position should be equal to zero. However, in actual practice there exists a small voltage at the null position. This may be on account of presence of harmonics in the input supply voltage and also due to harmonics produced in the output voltage on account of use iron core. There may be either an incomplete magnetic or electrical balance or both which result in a finite output voltage at the null position. This finite residual voltage is generally less than 1% of the maximum output voltage in the linear range. Other causes of residual voltage are stray magnetic fields and temperature effects. The residual voltage is shown in Fig. 25'41. However, with improved technological methods and with the use of better a.c. sources, the residual voltage can be reduced to almost a negligible value.

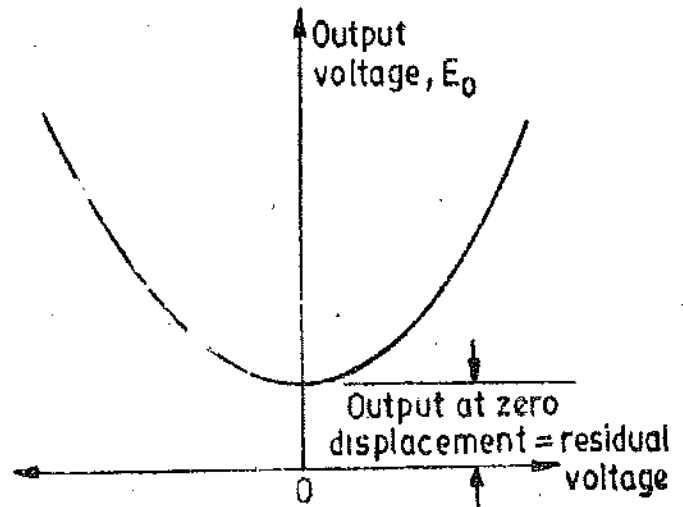

Fig. 25'41. Enlargement of hatched portion of Fig. 25'39.

25'271. Advantages of LVDTs. The advantages of a LVDT are :

1. *Linearity.* The output voltage of this transducer is practically linear for displacements up to 5 mm. A linearity of 0.05% is available in commercial LVDTs.
2. *Infinite resolution.* The change in output voltage is stepless as there are no mechanical elements to change the output voltage in discrete steps. The effective resolution depends more on test equipment than on the transducer. It is possible to build a transducer with a resolution as fine as 1×10^{-3} mm.
3. *High output.* It gives a high output and therefore many a times there is no need for intermediate amplification devices.
4. *High sensitivity.* The transducer possesses a high sensitivity as high as 40 V/mm.
5. *Ruggedness.* These transducers can usually tolerate a high degree of shock and vibration

without any adverse effects. They are simple and by virtue of being small and light in weight, they are stable and easy to align and maintain.

6. *Less friction.* There are no sliding contacts and hence there is less friction and less noise.

7. *Low hysteresis.* This transducer shows a low hysteresis and hence repeatability is excellent under all conditions.

8. *Low power consumption.* Most of the LVDTs consume a power of less than 1 W.

25.28.2. *Disadvantages of LVDTs.* 1. Relatively large displacements are required for appreciable differential output.

2. They are sensitive to stray magnetic fields but shielding is possible. This is done by providing magnetic shields with longitudinal slots.

3. Many a times, the transducer performance is affected by vibrations.

4. The receiving instrument must be selected to operate on a.c. signals or a demodulator network must be used if a d.c. output is required.

5. The dynamic response is limited mechanically by the mass of the core and electrically by the frequency of applied voltage. The frequency of the carrier should be at least ten times the highest frequency component to be measured.

6. Temperature affects the performance of the transducer. But when temperature effects are expected to affect the performance, manganin wire may be used instead of copper wire. Unfortunately manganin has a high resistivity and therefore its use results in loss of sensitivity. The sensitivity with manganin coils may be as low as 1/5 of that with copper coils. Temperature also causes phase shifting effects which may be minimized by using a capacitor across one of the secondary windings.

25.27.3. *Use of LVDTs.* The uses of LVDTs are numerous. Some of the major applications of LVDTs are listed below :

1. The LVDT can be used in all applications where displacement ranging from fractions of a mm to a few cm have to be measured. The LVDT acting as a primary transducer converts the displacement directly into an electrical output proportional to displacement. This is a fundamental conversion *i.e.* the mechanical variable (displacement in this case) is directly converted into an analogous signal (voltage in this case) in one stage only. In contrast, the electrical strain gauge requires the assistance of some form of a material to act as primary transducer to convert the mechanical displacement into strain which in turn is converted into an electrical signal by the strain gauge acting as a secondary transducer. Therefore two stages of signal conversion are involved in strain gauge while there is only one in case of LVDT when displacement is being measured.

2. Acting as a secondary transducer it can be used as a device to measure force, weight and pressure etc. The force measurement can be done by using a load cell as the primary transducer while fluid pressure can be measured by using Bourdon tube which acts as primary transducer. The force or the pressure is converted into a displacement which when applied to an LVDT (that acts as a secondary transducer) is converted into a voltage. In these applications the high sensitivity of LVDTs is a major attraction.

As explained earlier, the LVDT is not suited for fast dynamic measurements on account of mass of the core.

Example 25.20. The output voltage of a LVDT is 1.5 V at maximum displacement. At a load of 0.5 MΩ, the deviation from linearity is maximum and it is ±0.003 V from a straight line through origin. Find the linearity at the given load.

Solution. %age linearity = $\pm \frac{0.003}{1.5} \times 100 = \pm 0.2\%$.

Example 25.21. The output of an LVDT is connected to a 5 V voltmeter through an amplifier whose amplification factor is 250. An output of 2 mV appears across the terminals of LVDT when the core moves through a distance of 0.5 mm. Calculate the sensitivity of the LVDT and that of the whole set up. The milli-voltmeter scale has 100 divisions. The scale can be read to 1/5 of a division. Calculate the resolution of the instrument in mm.

Solution :

$$\text{Sensitivity of LVDT} = \frac{\text{output voltage}}{\text{displacement}} = \frac{2 \times 10^{-3}}{0.5} = 4 \times 10^{-3} \text{ V/mm} = 4 \text{ mV/mm}$$

Sensitivity of instrument = amplification factor \times sensitivity of LVDT

$$= 4 \times 10^{-3} \times 250 = 1 \text{ V/mm.} = 1000 \text{ mV/mm.}$$

$$1 \text{ scale division} = 5/100 \text{ V} = 50 \text{ mV.}$$

$$\text{Minimum voltage that can be read on the voltmeter} = \frac{1}{5} \times 50 = 10 \text{ mV.}$$

$$\therefore \text{Resolution of instrument} = 1 \times \frac{1}{1000} = 1 \times 10^{-3} \text{ mm.}$$

Example 25.22. A steel cantilever is 0.25 m long, 20 mm wide and 4 mm thick. (a) Calculate the value of deflection at the free end for the cantilever when a force of 25 N is applied at this end. The modulus of elasticity for steel is 200 GN/m².

An LVDT with a sensitivity of 0.5 V/mm is used. The voltage is read on a 10 V voltmeter having 100 divisions. Two tenths of a division can be read with certainty. (b) Calculate the minimum and maximum value of force that can be measured with this arrangement.

Solution :

$$(a) \text{ Moment of area of cantilever } I = \frac{1}{12} bt^3 = \frac{1}{12} \times (0.02) \times (0.004)^3 = 0.107 \times 10^{-9} \text{ m}^4.$$

$$\text{Deflection } x = \frac{Fl^3}{3EI} = \frac{25 \times (0.25)^3}{3 \times 200 \times 10^9 \times 0.107 \times 10^{-9}} = 6.08 \times 10^{-3} \text{ m} = 6.08 \text{ mm.}$$

$$(b) \text{ Deflection per unit force } \frac{x}{F} = \frac{6.08}{25} = 0.2432 \text{ mm/N.}$$

Overall sensitivity of measurement system

$$= 0.2432 \frac{\text{mm}}{\text{N}} \times 0.5 \frac{\text{V}}{\text{mm}} = 0.1216 \text{ V/N.}$$

$$1 \text{ scale division} = \frac{10}{1000} = 0.01 \text{ V. Since two tenths of a scale division can be read with}$$

$$\text{certainty, resolution} = \frac{2}{10} \times 0.01 = 0.002 \text{ V.}$$

$$\text{Minimum force that can be measured} = \frac{0.002}{0.1216} = 0.01645 \text{ N.}$$

$$\text{Maximum force that can be measured} = \frac{10}{0.1216} = 82.2 \text{ N}$$

25.28. Rotary Variable Differential Transformer (RVDT). A variation of linear variable

differential transformer (LVDT) may be used to sense angular displacement. This is the Rotary Variable Differential Transformer (RVDT). The circuit of a RVDT is shown in Fig. 25'42. It is similar to the LVDT except that its core is cam shaped and may be rotated between the windings by means of a shaft.

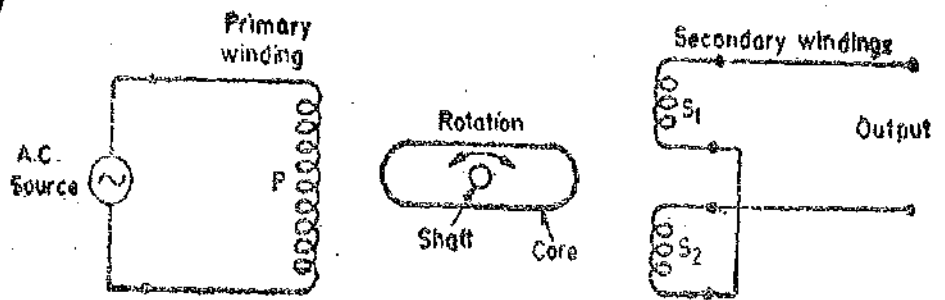

Fig. 25'42. Rotary variable differential transformer (RVDT).

The operation of a RVDT is similar to that of an LVDT. At the null position of the core, the output voltage of secondary windings S_1 and S_2 are equal and in opposition. Therefore, the net output is zero. Any angular displacement from the null position will result in a differential voltage output. The greater this angular displacement, the greater will be the differential output. Hence the response of the transducer is linear.

Clockwise rotation produces an increasing voltage of a secondary winding of one phase while counterclockwise rotation produces an increasing voltage of opposite phase. Hence, the amount of angular displacement and its direction may be ascertained from the magnitude and phase of the output voltage of the transducer.

25'29. Synchros

Synchros are normally used in control systems, but they have properties useful for instrumentation systems also. A synchro is an angular position transducer working on inductive principles wherein a variable coupling between primary and the secondary windings is obtained by changing the relative orientation of the windings. The primary winding is a single phase winding wound on a rotor made of laminations. The connections to the rotor winding are made through precision slip rings. The stator has a three-phase winding with the windings of the three phases displaced by 120° in space. Although the name "synchro" is universally used in the instrumentation field, trade names such as "selsyn" and "microsyn" are also commonly used.

The classical synchro system consists of two units :

- (i) a synchro transmitter, and
- (ii) a synchro receiver or motor.

The two units are connected as shown in Fig. 25'43. Initially winding S_2 of the stator of transmitter is positioned for maximum coupling with rotor winding [Fig 25'43 (a)]. Suppose its voltage is V . The coupling between S_1 and S_2 of the stator and primary (rotor) winding is a cosine function. Therefore the effective voltages in these windings proportional to $\cos 60^\circ$ or they are $V/2$ each. So as long as the rotors of the transmitter and receiver remain in this position, no current will flow between the windings because of the voltage balance.

When the rotor of the transmitter is moved to a new position, the voltage balance is disturbed. Assume that the rotor of the transmitter is moved through 30° [See Fig 25'43 (b)], the stator winding voltages of the transmitter will be changed to 0, $\sqrt{3}/2 V$ and $\sqrt{3}/2 V$ respectively. Thus there is a voltage imbalance between the stator windings of the transmitter and the receiver. This voltage imbalance between the windings causes currents to flow between the windings producing a torque that tends to rotate the rotor of the receiver to a position where the voltage balance is again restored. This balance is restored only if the receiver turns through the same angle as the transmitter and also the direction of rotation is the same as that of the transmitter. Thus a synchro can be used to determine the magnitude and the direction of an angular displacement.

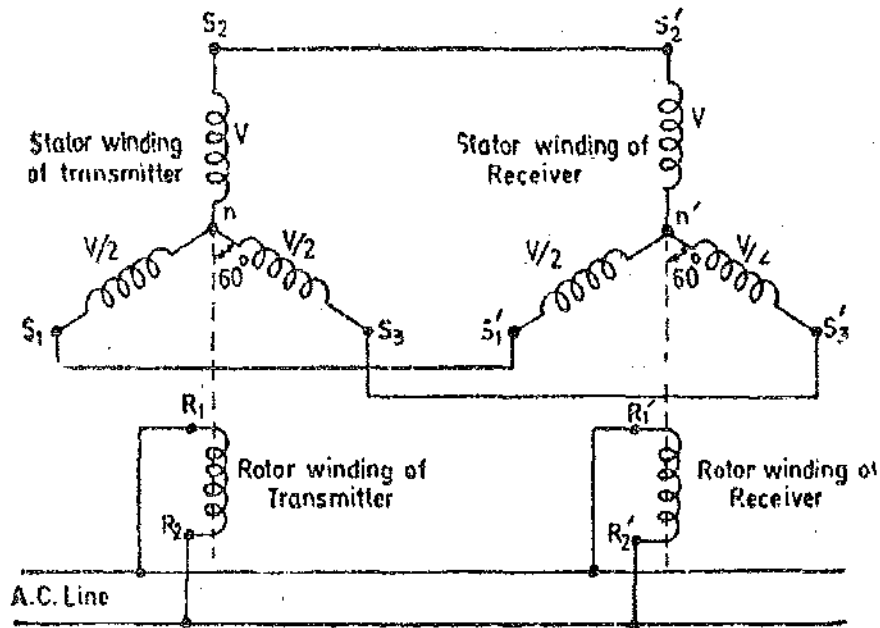

(a) Torque transmission using synchro transmitter.

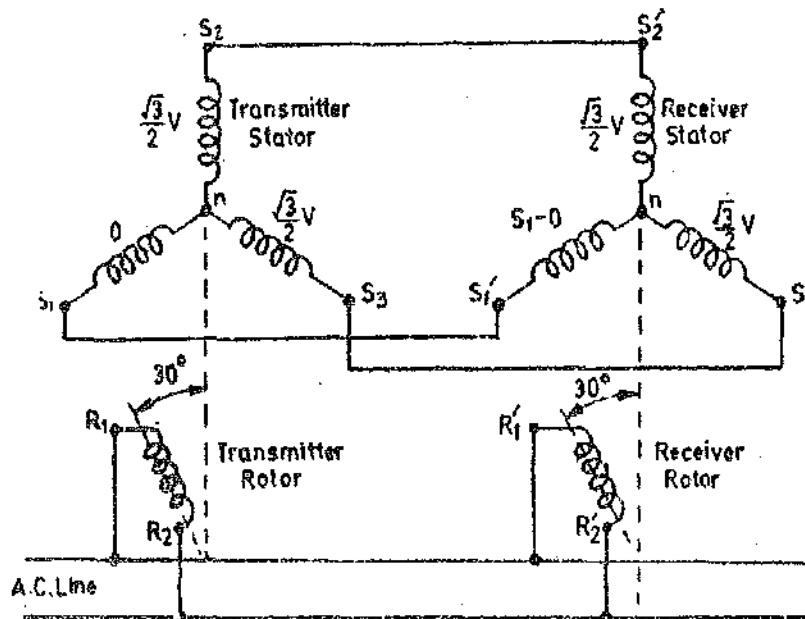
(b) Follow-up conditions of transmitter-receiver system.
Fig. 25'43. Principle of synchro operations.**25'30. Capacitive Transducers**

The principle of operation of capacitive transducers is based upon the familiar equation for capacitance of a parallel plate capacitor.

$$\text{Capacitance} \quad C = \frac{\epsilon A}{d}$$

where A = overlapping area of plates ; m^2 ,
 d = distance between two plates ; m ,
 t = permittivity (dielectric constant) ; F/m .

A parallel plate capacitors is shown in Fig. 25'44.

The capacitive transducer work on the principle of change of capacitance which may be caused by :

- (i) change in overlapping area A ,
- (ii) change in the distance d between the plates,
- and (iii) change in dielectric constant.

These changes are caused by physical variables like displacement, force, pressure in most of the cases. The change in capacitance may be caused by change in dielectric constant as is the case in measurement of liquid or gas levels.

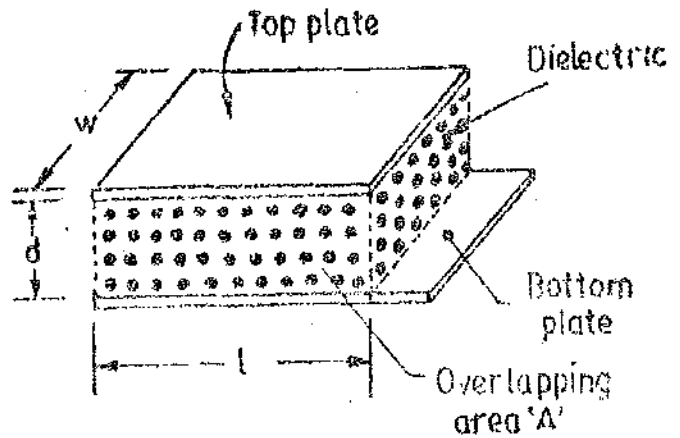

Fig. 25'44. Schematic diagram of a parallel-plate capacitor.

The capacitance may be measured with bridge circuits. The output impedance of a capacitive transducer is : $Z = 1/2\pi fC$.

In general, the output impedance of a capacitive transducer is high. This fact calls for a careful design of the output circuitry.

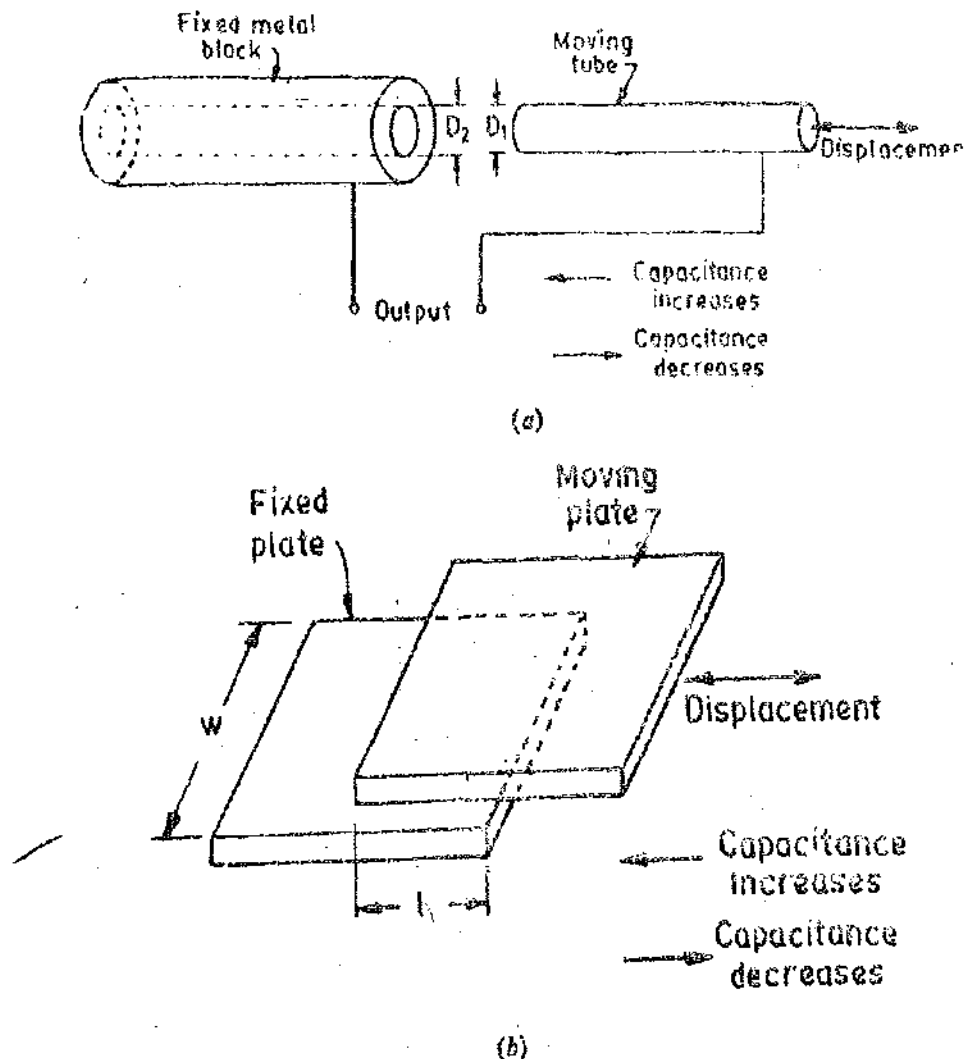

Fig. 25'45. Capacitive transducers working on the principle of change of capacitance with change of area.

The capacitive transducers are commonly used for measurement of linear displacement. These transducers use the following effects :

- (i) change in capacitance due to change in overlapping area of plates.
and (ii) change in capacitance due to change in distance between the two plates.

25.30.1. **Transducers Using Change in Area of Plates.** Examining the equation for capacitance it is found that the capacitance is directly proportional to the area, A of the plates. Thus the capacitance changes linearly with change in area of plates. Hence this type of capacitive transducer is useful for measurement of moderate to large displacements say from 1 mm to several cm. The elementary diagrams of two types of capacitive transducers are shown in Figs. 25.45(a) and (b). The area changes linearly with displacement and also the capacitance. Fig. 25.46 shows the variation of capacitance. As mentioned earlier the response is linear as shown, the initial non-linearity is due to edge effects.

For a parallel plate capacitor, the capacitance is :

$$C = \frac{\epsilon A}{d} = \frac{\epsilon lw}{d} \text{ F} \quad \dots(25.43)$$

where l = length of overlapping part of plates ; m,

and w = width of overlapping part of plates ; m.

$$\text{Sensitivity } S = \frac{\partial C}{\partial l} = \epsilon \frac{w}{d} \text{ F/m} \quad \dots(25.44)$$

The sensitivity is constant and therefore there is linear relationship between capacitance and displacement.

$$\text{Sensitivity for a fractional change in capacitance} = S' = \frac{\partial C}{C \partial l} = \frac{1}{l} \quad \dots(25.45)$$

This type of a capacitive transducer is suitable for measurement of linear displacements ranging from 1 to 10 cm. The accuracy is as high as 0.005%.

$$\text{For a cylindrical capacitor the capacitance is : } C = \frac{2\pi\epsilon l}{\log_e(D_2/D_1)} \text{ F} \quad \dots(25.46)$$

where l = length of overlapping part of cylinders ; m,

D_2 = inner diameter of outer cylindrical electrode ; m,

and D_1 = outer diameter of inner cylindrical electrode ; m.

$$\text{Sensitivity } S = \frac{\partial C}{\partial l} = \frac{2\pi\epsilon}{\log_e(D_2/D_1)} \text{ F/m} \quad \dots(25.47)$$

Therefore, the sensitivity is constant and the relationship between capacitance and displacement is linear as shown in Fig. 25.46.

The principle of change of capacitance with change in area can be employed for measurement of angular displacement. Fig. 25.47 (a) shows a two-plate capacitor. One plate is fixed and the other is movable. The angular displacement to be measured is applied to movable plate. The angular displacement changes the effective area between the plates and thus changes the capacitance. The capacitance is maximum when the two plates completely overlap each other i.e. when $\theta = 180^\circ$.

$$\therefore \text{Maximum value of capacitance } C_{max} = \frac{\epsilon A}{d} = \frac{\pi\epsilon r^2}{2d} \quad (25.48)$$

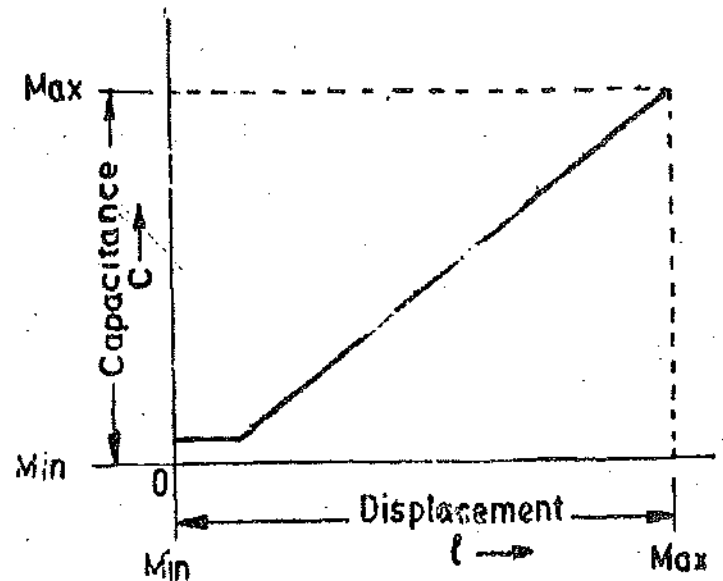

Fig. 25.46. Capacitance displacement curve of capacitive transducer (working on principle of change of plate area caused by change in displacement).

Capacitance at angle θ is

$$C = \frac{\epsilon r^2}{2d} \theta \quad \dots(25'49)$$

where θ = angular displacement in radian.

Sensitivity

$$S = \frac{\partial C}{\partial \theta} = \frac{\epsilon r^2}{2d} \quad \dots(25'50)$$

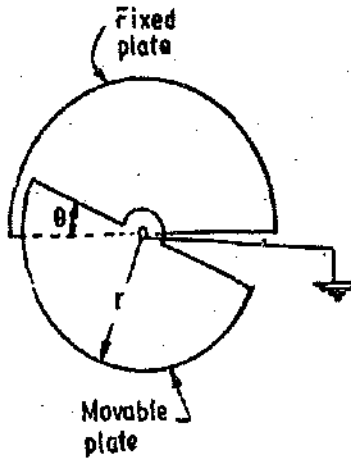

(a)

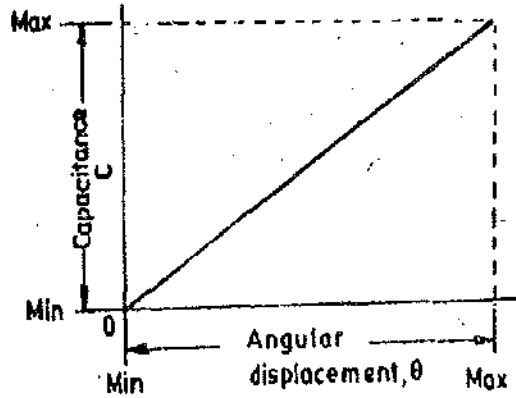

(b)

Fig. 25'47. Capacitive transducer for measurement of angular displacement.

Therefore, the variation of capacitance with angular displacement is linear. This is shown in Fig. 25'47 (b). It should be understood that the above mentioned capacitive transducer can be used for a maximum angular displacement of 180°.

25 30 2. Transducers Using Change in Distance Between Plates. Fig. 25'48 (a) shows the basic form of a capacitive transducer utilizing the effect of change of capacitance with change in distance between the two plates. One is a fixed plate and the displacement to be measured is applied to the other plate which is movable. Since, the capacitance, C , varies inversely as the distance d , between the plates the response of this transducer is not linear and as shown in Fig. 25'47 (b). Thus this transducer is useful only for measurement of extremely small displacements.

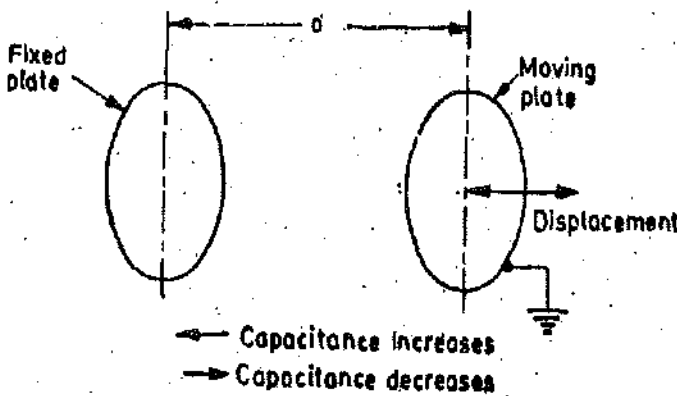

(a)

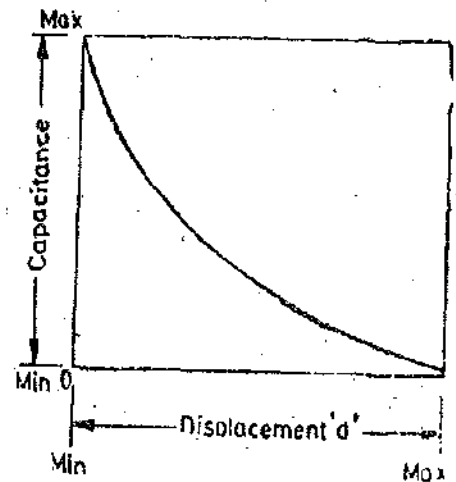

(b)

Fig. 25'48: Capacitive transducer using the principle of change of capacitance with change of distance between plates.

Sensitivity

$$S = \frac{\partial C}{\partial d} = -\frac{\epsilon A}{d^2} \quad \dots(25'51)$$

From Eqn. 25'51 it is clear that the sensitivity of this type of transducer is not constant but varies over the range of the transducer. Thus, as explained earlier transducer exhibits non-linear characteristics.

The relationship between variation of capacitance with variation of distance between plates is hyperbolic and is only approximately linear over a small range of displacement. The linearity can be closely approximated by use of a piece of dielectric material like mica having a high dielectric constant. In this type of transducer, a thin piece of mica thinner than the minimum gap distance is inserted between the plates.

Theoretically, the sensitivity of the transducer can be increased to any desirable value by making the distance between the plates extremely small. But a practical limit is reached when the electric field strength in the air gap exceeds the breakdown voltage. The breakdown limit in air at atmospheric pressure is about 3 kV/mm.

Fig. 25'49 shows an arrangement for measurement of linear displacement. The displacement when applied to the cantilever type spring plate moves it towards the second plate decreasing the distance. This increases the capacitance of the capacitor. It is clear that the capacitance of air dielectric capacitor does not vary linearly with change in distance between the plates, and therefore, this arrangement is fundamentally non-linear. However, linearity can be closely approximated by keeping the change in the distance small or by having a medium of high dielectric constant in the space between the two plates.

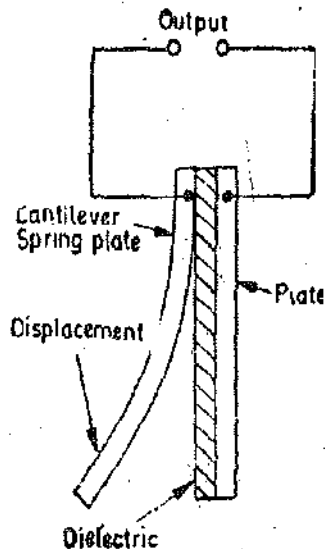

Fig. 25'49. Capacitive transducer using cantilever spring plate.

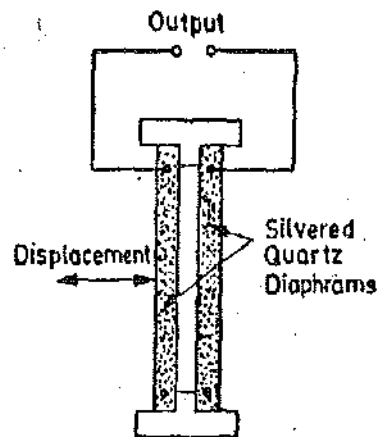

Fig. 25'50. Capacitive transducer using Quartz diaphragms.

Two silvered quartz diaphragms form a capacitor as shown in Fig. 25'50. The displacement of these diaphragms varies the capacitance of this capacitive transducer. This type of a transducer forms a pressure gauge which works very satisfactorily. If the pressure is reduced to perfect vacuum between the diaphragms, the transducer measures the absolute pressure of the surrounding medium. Quartz is used because it has a very low mechanical hysteresis. The disadvantage of this type of transducer is that it has high temperature co-efficient and this must be taken into consideration when making precision type measurements.

Rotational displacement can be measured with an arrangement shown in Fig. 25'51. As the rotor plates of the capacitor are displaced in the counter clockwise direction the capacitance increases. The change in the capacitance is a measure of the angular displacement. This capacitive transducer can be effectively used for measurement of torque.

25'30'3. Differential Arrangement. A linear characteristic can be achieved by using a differential arrangement for the capacitive displacement transducers. This arrangement using three plates is shown in Fig 25'51. P_1 and P_2 are fixed plates and M is the movable plate to which the displacement to be measured is applied. Thus we have two capacitors whose differential output is given.

Let the capacitance of these capacitors be C_1 and C_2 respectively, when the plate M is midway between the two fixed plates, under this condition the capacitances C_1 and C_2 are equal.

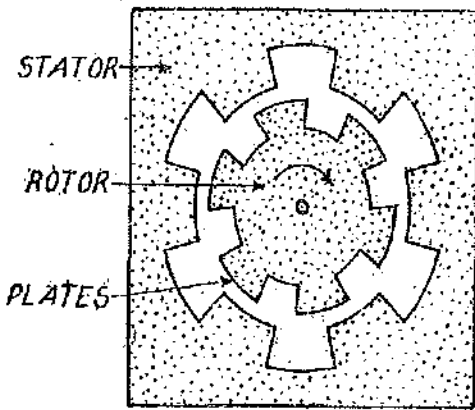

Fig 25'51. Capacitive transducer used for measurement of rotational displacement.

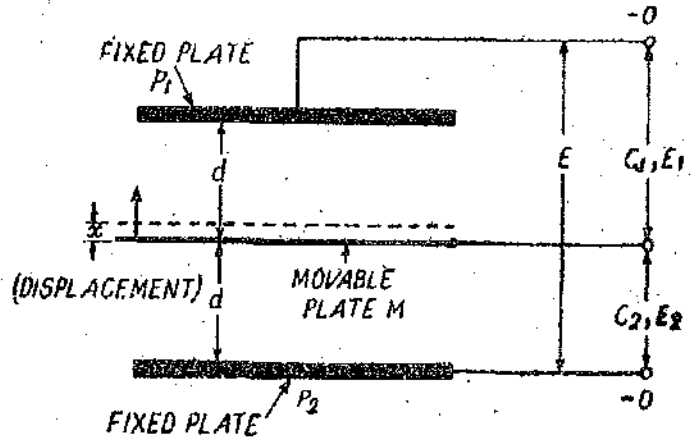

Fig. 25'52. Differential arrangement of capacitors.

$$C_1 = \frac{\epsilon A}{d} \text{ and } C_2 = \frac{\epsilon A}{d}$$

An alternating current voltage E is applied across plates P_1 and P_2 and the difference of the voltages across the two capacitances is measured.

Voltage across C_1 is $E_1 = \frac{EC_2}{C_1 + C_2}$

and voltage across C_2 is $E_2 = \frac{EC_1}{C_1 + C_2}$

When the movable plate is midway between the two fixed plates $C_1 = C_2$ and therefore $E_1 = E_2 = E/2$.

∴ Differential output when the movable plate is midway $\Delta E = E_1 - E_2 = 0$.

Let the movable plate be moved up due to displacement x . Therefore the values C_1 and C_2 become different resulting in a differential voltage output.

Now $C_1 = \frac{\epsilon A}{d-x}$ and $C_2 = \frac{\epsilon A}{d+x}$.

∴ $E_1 = \frac{C_2 E}{C_1 + C_2} = \frac{\epsilon A / (d+x)}{\epsilon A / (d-x) + \epsilon A / (d+x)} E = \frac{d-x}{2d} E$

and $E_2 = \frac{C_1 E}{C_1 + C_2} = \frac{\epsilon A / (d-x)}{\epsilon A / (d-x) + \epsilon A / (d+x)} E = \frac{d+x}{2d} E$

∴ Differential output voltage = $\Delta E = E_2 - E_1 = \frac{d+x}{2d} E - \frac{d-x}{2d} E = \frac{x}{d} E$... (25'52)

Therefore the output voltage varies linearly as the displacement x .

Sensitivity $S = \frac{\Delta E}{x} = \frac{E}{d}$... (25'53)

The differential method can be used for displacements of 10^{-8} mm to 10 mm with an accuracy of 0.1%.

25'30.4. Variation of Dielectric Constant for Measurement of Displacement. The third principle used in capacitive transducers is the variation of capacitance due to change in dielectric constant. Fig. 25'53 shows a capacitive transducer for measurement of linear displacement working on the above mentioned principle. It has a dielectric of relative permittivity ϵ_r .

Initial capacitance of transducer = $C = \epsilon_0 \frac{wl_1}{d} + \epsilon_0 \epsilon_r \frac{wl_2}{d} = \epsilon_0 \frac{w}{d} [l_1 + \epsilon_r l_2]$... (25.54)

Let the dielectric be moved through a distance x in the direction indicated. The capacitance changes from C to $C + \Delta C$.

$\therefore C + \Delta C = \epsilon_0 \frac{w}{d} (l_1 - x) + \epsilon_0 \epsilon_r \frac{w}{d} (l_2 + x) = \epsilon_0 \frac{w}{d} [l_1 - x + \epsilon_r (l_2 + x)]$
 $= \epsilon_0 \frac{w}{d} [l_1 + \epsilon_r l_2 + x(\epsilon_r - 1)] = C + \epsilon_0 \frac{wx}{d} (\epsilon_r - 1)$... (25.55)

Change in capacitance $\Delta C = \epsilon_0 \frac{wx}{d} (\epsilon_r - 1)$... (25.56)

Hence the change in capacitance is proportional to displacement.

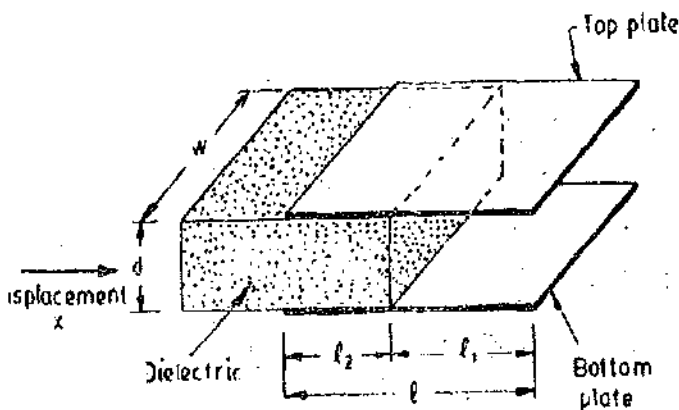

Fig. 25.53. Capacitive transducer using principle of change in dielectric constant for measurement of displacement.

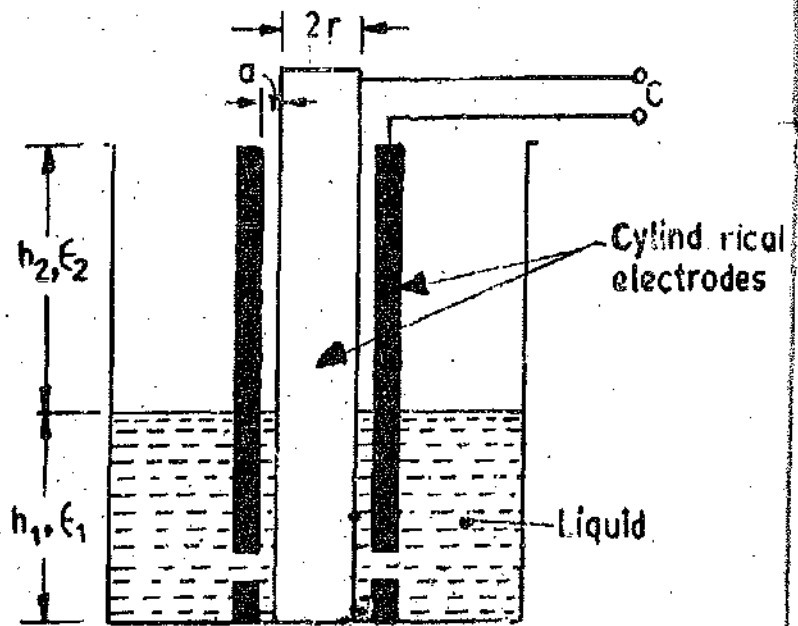

Fig. 25.54. Capacitive transducer for measurement of level of a non-conducting liquid.

25.30.5. Variation of Dielectric Constant for Measurement of Liquid Level. Capacitive transducers using the principle of change of capacitance with change of dielectric are normally used for measurement of liquid levels. Fig. 25.54 shows a capacitive transducer used for measurement of level of a non-conducting liquid.

The electrodes are two concentric cylinders and the non-conducting liquid acts as the dielectric. At the lower end of the outer cylinder there are holes which allow passage of liquid. In case these holes are small, they provide mechanical damping of the surface variation.

The value of capacitance for this capacitor is approximately given by :

$C = 2 \frac{h_1 \epsilon_1 + h_2 \epsilon_2}{\log_e (1 - a/r)} F$... (25.57)

where h_1 = height of liquid ; m, h_2 = height of cylinder above liquid surface ; m,
 ϵ_1 = permittivity of the liquid ; F/m, ϵ_2 = permittivity of gas above liquid ; F/m,
 r = outside radius of inner cylinders ; m, and a = distance between inner and outer cylinders ; m.
 Eqn. 25.57 is based upon the assumptions that $h \gg r_2$ and $r \gg r_2 - r_1$.

25.30.6. Frequency Response of Capacitive Transducers. Fig. 25.55 shows a simple circuit for capacitive transducers using change in capacitance due to change in distance between plates. Let th

distance between the plates be d when they are stationary. Under this condition no current flows and output voltage is $e_0 = E_b$.

Let a displacement x_1 be applied, causing a change in capacitance. This produces a current and the voltage is :

$$e_1 = e_0 - E_b \text{ with } x_1 = x - d.$$

The following analysis is done for small displacements with $x_1/d < 0.1$.

$$\text{Transfer function} = \frac{E_1(s)}{X_1(s)} = \frac{K\tau s}{1 + \tau s}$$

where $K = \frac{E_b}{d}$ V/m, $\tau = \text{time constant} = RC$

$$\text{Sinusoidal transfer function} \frac{E_1(j\omega)}{X_1(j\omega)} = \frac{j\omega K\tau}{1 + j\omega\tau}$$

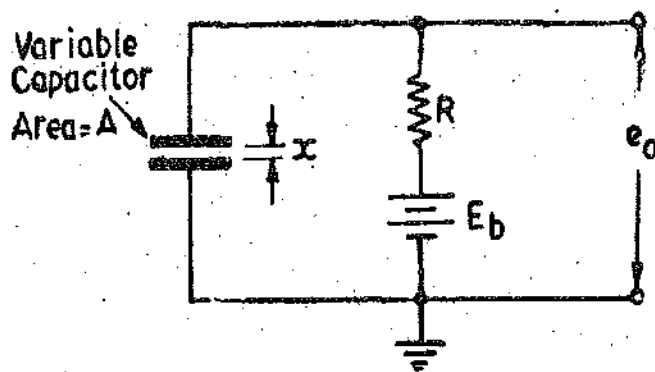

Fig. 25.55. Capacitive transducer.

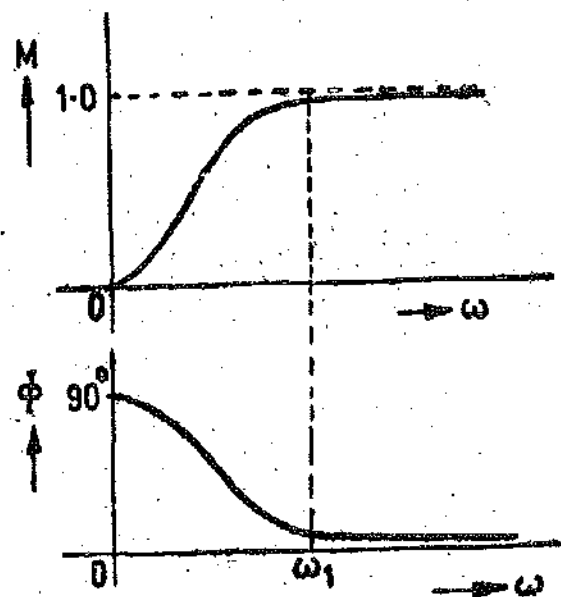

Fig. 25.56. Frequency response of capacitive transducers.

The amplitude ratio is thus :

$$M = \left| \frac{E_1}{KX_1} (j\omega) \right| = \frac{\omega\tau}{\sqrt{1 + \omega^2\tau^2}} = \frac{1}{\sqrt{1 + (1/\omega\tau)^2}} \quad \dots(25.58)$$

Phase shift $\phi = \pi/2 - \tan^{-1} \omega\tau$ rad. ... (25.59)

The frequency response curves are shown in Fig. 25.56.

Eqn. 25.58 shows that this arrangement (Fig. 25.55) cannot be used for static measurements as output is zero for $\omega = 0$. This arrangement should not be used for low frequency applications as it will result in inaccuracies (See Fig. 25.56). The arrangement should be used for high frequency applications (beyond a frequency ω_1) in order to achieve high degree of accuracy in measurements.

Examining Eqns. 25.58 and 25.59, we have $M = \left| \frac{E_1}{X_1} (j\omega) \right| \approx K$ and $\phi = 0$ for $\omega\tau \gg 1$.

Thus both magnitude ratio as well phase shift are constant and are independent of frequency.

In order to make $\omega\tau \gg 1$ for low frequencies, τ has to be made large. Now $\tau = RC$. Thus for a given capacitor τ can be increased by increasing the value of resistance R . This resistance is of the order of $1 \text{ M}\Omega$ or more. In order to prevent loading of capacitive transducers, readout or measuring device should have an impedance of at least $10 \text{ M}\Omega$ (or more).

25'307. Advantages of Capacitive Transducers. The major advantages of capacitive transducers are :

(i) They require extremely small forces to operate them and hence are very useful for use in small systems.

(ii) They are extremely sensitive.

(iii) They have a good frequency response. This response is as high as 50 kHz and hence they are very useful for dynamic studies.

(iv) They have a high input impedance and therefore the loading effects are minimum.

(v) A resolution of the order of 2.5×10^{-3} mm can be obtained with these transducers.

(vi) The capacitive transducers can be used for applications where stray magnetic fields render the inductive transducers useless.

(vii) The force requirements of capacitive transducers is very small and therefore they require small power to operate them.

25'308. Disadvantages of Capacitive Transducers. The principal disadvantages of capacitive transducers are :

(i) The metallic parts of the capacitive transducers must be insulated from each other. In order to reduce the effects of stray capacitances, the frames must be earthed.

(ii) The capacitive transducers show non-linear behaviour many a times on account of edge effects. Therefore guard rings must be used to eliminate this effect. Guard rings are also a must in order to eliminate the effect of stray electric fields, especially when the transducers have a low value of capacitance of the order of pF.

(iii) The output impedance of capacitive transducers tends to be high on account of their small capacitance value. This leads to loading effects. The output impedance depends upon the frequency of the signal used to determine the value of capacitance. For capacitances lying between 10–500 pF, the frequencies used are such that they give an output impedance in the range of 1 k Ω to 10 M Ω . This high value of output impedance means that the insulation resistance must be kept high, to avoid the shunting of the capacitance unduly and reducing the sensitivity. Both the above conditions are difficult to meet in practice on account of change of humidity.

(iv) The cable connecting the transducer to the measuring point is also a source of error. The cable may be source of loading resulting loss of sensitivity. Also loading makes the low frequency response poor.

Let us take a capacitive transducer of capacitance C . This capacitor is used with its polarizing source to produce an emf E_0 at no load. Let a load impedance Z_L be connected across it. The value of voltage with load connected is :

$$E_L = \frac{E_0}{1 + Z_0/Z_L} \quad (\text{See Eqn. 2'18 page 24})$$

and impedance of transducer is $Z_0 = 1/j\omega C$

$$E_L = \frac{E_0}{1 + 1/j\omega C Z_L} \quad \dots(25'69)$$

In order to have good response $\omega C Z_L$ should be as large as possible. This means that for a particular value of C and Z_L , ω should be large. Thus capacitive transducers should be used for dynamic measurements at high frequencies.

In order to good response at low frequencies the value of the capacitance should be large so that output impedance Z_0 of the transducer is high. This thereby makes E_L nearly equal to E_0 .

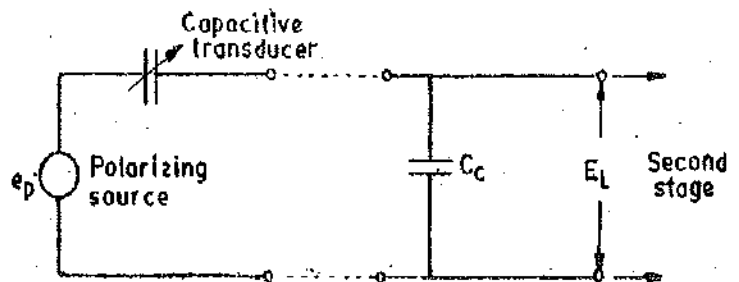

Fig. 25'57. Capacitive transducer with its output cable.

The capacitive transducers are connected to the second stage of the instrumentation system through cables. The cables are a source of loading. Consider a capacitive transducer as shown in Fig. 25'57.

Let C = capacitance of transducer ; F , and C_c = capacitance of the cable ; F .

If we neglect the leakage resistance, the output impedance of transducer is $Z_0 = 1/j\omega C$

Impedance of load (taking cable as the load) is : $Z_L = 1/j\omega C_c$

$$\therefore \text{Voltage at the second stage } E_L = \frac{E_0}{1 + j\omega C_c / j\omega C} = \frac{C}{C + C_c} E_0 \quad \dots(25'61)$$

Thus in order that the loading effects be minimized the capacitance of the cable should be as small as possible as compared to capacitance of transducer or $C_c \ll C$. This requires short lengths of cables to have high sensitivity. Consider the polarizing voltage to be short circuited it is then seen that C and C_c are connected in parallel.

$$\therefore \text{Minimum resonant frequency } f_{min} = \frac{1}{2\pi R / (C + C_c)} \text{ H.z} \quad \dots(25'62)$$

where R_i = leakage resistance.

If the cable capacitance C_c is high, the frequency f_{min} decreases. Hence cable must have small capacitance to improve low frequency response.

(v) The capacitance of a capacitive transducer may be changed on account of presence of extraneous matter like dust particles and moisture.

(vi) The capacitive transducers are temperature sensitive and therefore any change in temperature adversely affects their performance.

(vii) The instrumentation circuitry used with these transducers is very complex.

25'30'9. Uses of Capacitive Transducers. (i) Capacitive transducers can be used for measurement of both linear and angular displacements. The capacitive transducers are highly sensitive and can be used for measurement of extremely small displacements down to the order of molecular dimensions i.e., 0.1×10^{-6} mm.

This is on account of the fact that small capacitance changes produced on account of small displacements can be measured. In practice it is possible to detect capacitance changes of the order of 1aF^* and that too with a good degree of accuracy.

On the other hand they can be used for measurement of large distances upto about 30 m as in aeroplane altimeters. The change in displacement method is generally preferable for either very small or very large displacements. The change in area method is used for measurement of displacements ranging from 10 mm to 100 mm.

(ii) Capacitive transducers can be used for the measurement of force and pressure. The force and pressure to be measured are first converted to displacement which causes a change of capacitance.

(iii) Capacitive transducers can also be used directly as pressure transducers in all those cases where the dielectric constant of a medium changes with pressure. For instance the dielectric constant of Benzene changes by 0.5 per cent in the range of pressure of 1 to 1000 times the atmospheric pressure. Similarly, the dielectric constant of air at 19°C changes from 1.0006 to 1.0548 in the same pressure range. Variation of dielectric constant with pressure also occurs in solids, primarily in crystals like MgO, LiF, NaCl, KCl and KBr.

(iv) Capacitive transducers are used for measurement of humidity in gases since the dielectric constant of gases changes with change in humidity thereby producing a change in capacitance. The change in capacitance is quite small but is detectable. An idea of change of dielectric constant can be had from the example of air. The dry air at 45°C has a dielectric constant of 1.000247 and that

*1 aF = 10^{-18} F,

of air saturated with water is 1.000593 at the same temperature. These measurements are carried out with microwave techniques and the frequency is of the order of 10 GHz.

(v) Capacitive transducers are commonly used in conjunction with mechanical modifiers for measurement of volume, density, liquid level, weight etc.

Example 25.23. Fig. 25.58 shows a capacitive transducer using five plates. The dimensions of each plate are 25×25 mm and the distance between plates is 0.25 mm. This arrangement is to be used for measurement of displacement by observing the change in capacitance with the distance x . Calculate the sensitivity of the device. Assume that the plates are separated by air. The permittivity of air is 8.85×10^{-12} F/m.

Solution. The five plate transducer forms a combination of four capacitors connected in parallel. If the movable plate is moved through a distance x ,

$$\text{Capacitance of each capacitor } C' = \frac{\epsilon_0(l-x)w}{d}$$

where w = width of each plate,

$$\text{Capacitance of transducer } C = \frac{4\epsilon_0(l-x)w}{d}$$

$$\begin{aligned} \text{Sensitivity of transducer } \frac{\partial C}{\partial x} &= \frac{-4\epsilon_0 w}{d} = \frac{-4 \times 8.85 \times 10^{-12} \times 25 \times 10^{-3}}{0.25 \times 10^{-3}} = -3540 \text{ pF/m.} \\ &= 3.54 \text{ pF/mm. (Disregarding the sign).} \end{aligned}$$

Example 25.24. A capacitive transducer uses two quartz diaphragms of area 750 mm^2 separated by a distance of 3.5 mm. A pressure of 900 kN/m^2 when applied to the top diaphragm produces a deflection of 0.6 mm. The capacitance is 370 pF when no pressure is applied to the diaphragms. Find the value of capacitance after the application of a pressure of 900 kN/m^2 .

Solution. Suppose C_1 and C_2 are respectively the values of capacitance before and after application of pressure. Let d_1 and d_2 be the values of distance between the diaphragms for the corresponding pressure conditions.

$$C_1 = \epsilon A/d_1 \text{ and } C_2 = \epsilon A/d_2$$

$$\text{or } \frac{C_2}{C_1} = \frac{d_1}{d_2} \quad \therefore C_2 = C_1 \times \frac{d_1}{d_2}$$

$$\text{But } d_1 = 3.5 \text{ mm and } d_2 = 3.5 - 0.6 = 2.9 \text{ mm.}$$

$$\therefore \text{Value of capacitance after application of pressure } C_2 = 370 \times \frac{3.5}{2.9} = 450.69 \text{ pF.}$$

Example 25.25. A pressure measuring instrument uses a capacitive transducer having a spacing of 4 mm between its diaphragms. A pressure of 600 kN/m^2 produces an average deflection of 0.3 mm of the diaphragm of the transducer. The transducer which has a capacitance of 300 pF before application of pressure is connected in an oscillator circuit having a frequency of 100 kHz. Determine the change in frequency of the oscillator after the pressure is applied to the transducer.

Solution. The subscript 1 is used for values before application of pressure and 2 is used for values after application of pressure.

$$\text{Resonant frequency } f_0 = \frac{1}{2\pi\sqrt{LC}}$$

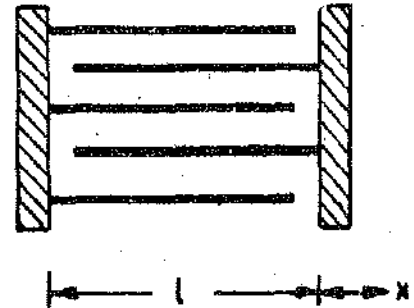

Fig. 25.58. Capacitive transducer for measurement of linear displacement.

The inductance is constant but the capacitance is variable.

$$\therefore f_{01} = \frac{1}{2\pi\sqrt{LC_1}} \quad \text{and} \quad f_{02} = \frac{1}{2\pi\sqrt{LC_2}}$$

Thus we have, $f_{02}/f_{01} = \sqrt{C_1/C_2}$

But $C_1 = \epsilon A/d_1$ and $C_2 = \epsilon A/d_2$.

$$\therefore \frac{f_{02}}{f_{01}} = \sqrt{\frac{C_1}{C_2}} = \sqrt{\frac{d_2}{d_1}}$$

The frequency of the oscillator after the application of pressure is :

$$f_{02} = \sqrt{\frac{d_2}{d_1}} \times f_{01} = \sqrt{\frac{-0.3 + 4.0}{4.0}} \times 100 = 96.18 \text{ kHz}$$

\therefore Change in frequency of oscillator = $100 - 96.18 = 3.82 \text{ kHz}$.

Example 25.26. A capacitive transducer is made up of two concentric cylindrical electrodes. The outer diameter of the inner cylindrical electrode is 3 mm and the dielectric medium is air. The inner diameter of the outer electrode is 3.1 mm. Calculate the dielectric stress when a voltage of 100 V is applied across the electrodes. Is it within safe limits? The length of electrodes is 20 mm. Calculate the change in capacitance if the inner electrode is moved through a distance of 2 mm. The breakdown strength of air is 3 kV/mm.

Solution. Length of air gap between the two electrodes $\frac{3.1 - 3.00}{2} = 0.05 \text{ mm}$.

\therefore Dielectric stress = $\frac{100}{0.05} = 2000 \text{ V/mm} = 2 \text{ kV/mm}$.

The breakdown strength of air is 3 kV/mm, and hence the dielectric is safe.

Capacitance of the transducer

$$C = \frac{2\pi\epsilon l}{\log_e(D_2/D_1)} = \frac{2\pi \times 8.85 \times 10^{-12} \times 2 \times 10^{-2}}{\log_e(3.1/3)} \text{ F} = 33.9 \text{ pF}$$

The moving in electrode is shifted through a distance of 2 mm.

$\therefore l = 20 - 2 = 18 \text{ mm} = 18 \times 10^{-3} \text{ m}$.

New value of capacitance $C' = \frac{2\pi \times 8.85 \times 10^{-12} \times 1.8 \times 10^{-2}}{\log_e(3.1/3)} \text{ F} = 30.5 \text{ pF}$.

\therefore Change in value of capacitance $\Delta C = 33.9 - 30.5 = 3.4 \text{ pF}$.

Example 25.27. A capacitive transducer circuit used for measurement of linear displacement. The transducer is a parallel plate air capacitor wherein the capacitance can be changed by changing the distance between the plates. This transducer is to be used for dynamic measurements. Suppose a flat frequency response with an amplitude ratio within 5% is required down to a frequency range of 20 Hz, what is the minimum allowable value of time constant? Calculate the phase shift at this frequency. The area of plates is 300 mm² and the distance between plates is 0.125 mm. Calculate the value of series resistance R . What is the amplitude ratio at 5 Hz with the above time constant?

Calculate the high frequency voltage sensitivity of the transducer if the battery voltage is 100 V.

Solution. For a flat response within 5 per cent, the amplitude ratio is $M = 1 - 0.05 = 0.95$.

$$\text{From Eqn. 25.58 } M = \frac{1}{\sqrt{1 + (1/\omega\tau)^2}} \quad \text{or} \quad 0.95 = \frac{1}{\sqrt{1 + (1/2\pi \times 20 \times \tau)^2}}$$

or Minimum time constant $\tau = 24.2 \times 10^{-8} \text{ s} = 24.2 \text{ ns}$.

From Eqn. 25'59, phase shift $\phi = \pi/2 - \tan^{-1} \omega\tau = \pi/2 - \tan^{-1} (2\pi \times 20 \times 24.2 \times 10^{-3}) = 18.2^\circ$.

$$\text{Capacitance } C = \frac{8.85 \times 10^{-12} \times 300 \times 10^{-6}}{0.125 \times 10^{-3}} = 21.2 \times 10^{-12} \text{ F}$$

$$\therefore \text{Series resistance } R = \frac{\tau}{C} = \frac{24.2 \times 10^{-3}}{21.2 \times 10^{-12}} = 1.14 \times 10^9 \Omega = 1140 \text{ M}\Omega$$

$$\text{Amplitude ratio at 5 Hz is : } M = \frac{1}{\sqrt{1 + (1/2 \times \pi \times 5 \times 24.2 \times 10^{-3})^2}} = 0.605$$

Thus the output is reduced nearly to 60% of its high frequency value. Therefore this transducer arrangement cannot be used for low frequency applications.

High frequency sensitivity of the transducer

$$K = \frac{E_s}{d} = \frac{100}{0.125 \times 10^{-3}} = 800 \times 10^3 \text{ V/m} = 800 \text{ kV/m.}$$

Example 25'29. A pushpull non-contact capacitive transducer is shown in Fig. 25'59. It consists of four parallel plates separated by air. Plates A, C and D are fixed and plate B can be moved. Plate B has a thickness t and is at a distance d from plates on either side. Plates B, C, D are all of length l , while plate A has length $2l$. All plates have a width w . The gap between plates C and D can be considered as negligible. Neglecting the end effects, derive expressions for capacitances C_{AC} and C_{AD} for movement of the midpoint of plate B between $x = \pm l/2$. $x=0$ is the position of symmetry.

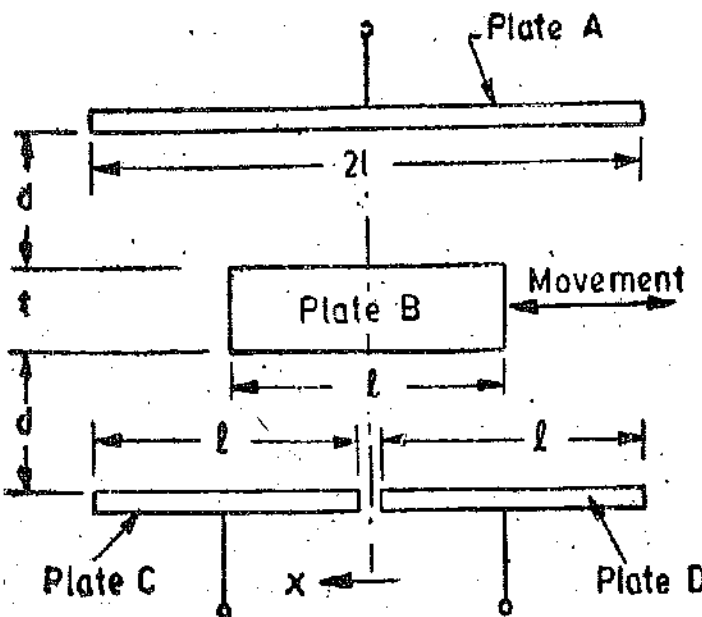

Fig. 25'59. Pushpull capacitive transducer.

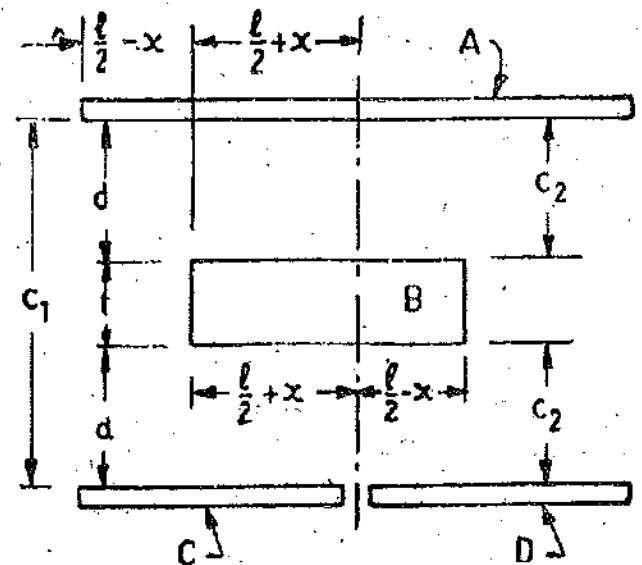

Fig. 25'60

Solution Fig. 25'60 shows a simplified arrangement where the central plate B is moved to the left by a distance x .

The capacitance between plates A and C is combination of capacitance C_1 in parallel with a series combination of two capacitances each of value C_2 .

$$C_1 = \frac{\epsilon_0 (l/2 - x)w}{2d + t} \quad \text{and} \quad C_2 = \frac{\epsilon_0 (l/2 + x)w}{d}$$

$$\therefore \text{Capacitance } C_{AC} = C_1 + \frac{C_2}{2} = \frac{\epsilon_0 (l/2 - x)w}{2d + t} + \frac{\epsilon_0 (l/2 + x)w}{2d} = \epsilon_0 w \left[\frac{2ld + l/2 + tx}{2d(2d - t)} \right]$$

$$\text{Similarly capacitance between plates A and D } C_{AD} = \epsilon_0 w \left[\frac{2ld + l/2 + tx}{2d(2d + t)} \right]$$

2531. Piezo-electric Transducers

A piezo-electric material is one in which an electric potential appears across certain surfaces of a crystal if the dimensions of the crystal are changed by the application of a mechanical force. This potential is produced by the displacement of charges. The effect is reversible, *i.e.*, conversely, if a varying potential is applied to the proper axis of the crystal, it will change the dimensions of the crystal thereby deforming it. This effect is known as piezo-electric effect. Elements exhibiting piezo-electric qualities are sometimes are called as electro-resistive elements.

Common piezo-electric materials include Rochelle salts, ammonium dihydrogen phosphate, lithium sulphate, dipotassium tartarate, potassium dihydrogen phosphate, quartz, and ceramics *A* and *B*. Except for quartz and ceramics *A* and *B*, the rest are man-made crystals grown from aqueous solutions under carefully controlled conditions. The ceramic materials are polycrystalline in nature. They are, basically, made of barium titanate. They do not have piezo-electric properties in their original state but these properties are produced by special polarizing treatment.

The materials that exhibit a significant and useful piezo-electric effect are divided into two categories : (i) Natural group, and (ii) Synthetic group

Quartz and Rochelle salt belong to natural group while materials like lithium sulphate, ethylene diamine tartarate belong to the synthetic group.

The piezo-electric effect can be made to respond to (or cause) mechanical deformations of the material in many different modes. The modes can be : thickness expansion, transverse expansion, thickness shear, and face shear. The mode of motion effected depends on the shape of the body relative to the crystal axis and location of the electrodes. A piezo-electric element used for converting mechanical motion to electrical signals may be thought as charge generator and a capacitor. Mechanical deformation generates a charge and this charge appears as a voltage across the electrodes. The voltage is $E=Q/C$.

The piezo-electric effect is direction sensitive. A tensile force produces a voltage of one polarity while a compressive force produces a voltage of opposite polarity.

A piezo-electric crystal is shown in Fig. 25'61.

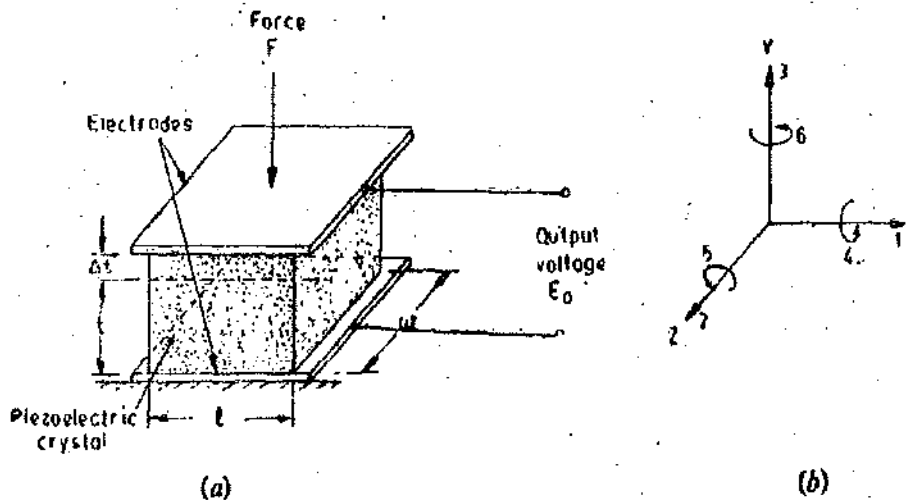

Fig. 25'61. (a) Piezo electric crystal used for measurement of force.
(b) Axis numbering system for the crystal.

The magnitude and polarity of the induced surface charges are proportional to the magnitude and direction of the applied force *F*.

Charge $Q=dF$ coulomb

...(25'63)

where d =charge sensitivity of the crystal, C/N ; (It is constant for a given crystal)

and F =applied force, N.

The force F causes a change in thickness of the crystal.

$$\therefore F = \frac{AE}{t} \Delta t \text{ newton} \quad \dots(25'64)$$

where A = area of crystal ; m^2 , t = thickness of crystal ; m , and E = Young's modulus, N/m^2 .

$$\text{Young's modulus } E = \frac{\text{stress}}{\text{strain}} = \frac{Ft}{A\Delta t} \text{ N/m}^2 \quad \dots(25'65)$$

Area $A = wl$ where w = width of crystal ; m , and l = length of crystal ; m .

\therefore From Eqns. 25'63 and 25'64, we have, charge :

$$Q = d \frac{AE}{t} \Delta t \text{ coulomb} \quad \dots(25'66)$$

The charge at the electrodes gives rise to an output voltage E_0 ,

$$\text{Voltage } E_0 = \frac{Q}{C_p} \text{ volt} \quad \dots(25'67)$$

where C_p = capacitance between electrodes ; F .

Capacitance between electrodes $C_p = \epsilon_r \epsilon_0 A/t$

From Eqns. 25'63 and 25'67 we have :

$$E_0 = \frac{dF}{\epsilon_r \epsilon_0 A/t} = \frac{dt}{\epsilon_r \epsilon_0} \frac{F}{A} \quad \dots(25'68)$$

But $\frac{F}{A} = P$ = pressure or stress in N/m^2 .

$$\therefore E_0 = \frac{d}{\epsilon_r \epsilon_0} t P \quad \dots(25'69)$$

$$= g t P \quad \dots(25'70)$$

$$\text{where } g = \frac{d}{\epsilon_r \epsilon_0} \quad \dots(25'71)$$

' g ' is the voltage sensitivity of the crystal. This is constant for a given crystal cut. Its units are Vm/N .

$$\text{Now } g = \frac{E_0}{tP} = \frac{E_0/t}{P} \quad \dots(25'72)$$

But E_0/t = electric field strength, V/m , Let $\epsilon = E_0/t$ = electric field

$$\therefore g = \frac{\text{electric field}}{\text{stress}} = \frac{\epsilon}{P} \quad \dots(25'73)$$

From Eqn. 25'71,

$$\text{Charge sensitivity } d = \epsilon_r \epsilon_0 g \text{ F/N} \quad \dots(25'74)$$

Typical values of g are : Barium titanate : $12 \times 10^{-3} \text{ Vm/N}$. Quartz : $50 \times 10^{-3} \text{ Vm/N}$.

The permittivity of these materials is :

Barium titanate : $12.5 \times 10^{-9} \text{ F/m}$, Quartz : $40.6 \times 10^{-12} \text{ F/m}$.

Hence typical values of charge sensitivity, d , for these materials is :

Barium titanate : $12.5 \times 10^{-9} \times 12 \times 10^{-3} \text{ C/N} \approx 150 \text{ pC/N}$.

Quartz : $40.6 \times 10^{-12} \times 50 \times 10^{-3} \text{ C/N} \approx 2 \text{ pC/N}$.

Sometimes it is desired to express the output voltage or charge in terms of deflection rather than in terms of either stress or force. This is because it is really the deformation that causes the

charge generation. Thus we must know the modulus of elasticity of the material for this purpose. The values of modulus of elasticity are :

Barium titanate : 12×10^{10} N/m, Quartz : 8.6×10^{10} N/m².

It has been stated earlier that the piezo-electric effect is direction sensitive. The main characteristics of piezo-electric motion to voltage transducers can be illustrated by considering only one common mode of deformation *i.e.* thickness expansion. For this mode the physical arrangement is shown in Fig. 25.61 (a). Various double-subscripted physical constants are used to describe numerically the phenomena occurring. The convention is that first subscript refers to the direction of the electrical effect and the second to that of the mechanical effect. The axis number system is given in Fig. 25 61 (b).

The two main families of constants *i.e.* the 'd' constants and 'g' constants are considered. For barium titanate the commonly used constants are d_{33} and g_{33} .

$$g_{33} = \frac{\text{field produced in direction 3}}{\text{stress applied in direction 3}} = \frac{E_0/t}{F/A} \dots (25.75)$$

Voltage output $E_0 = g_{33} \times \frac{F}{A} \times t = g_{33} t P \dots (25.76)$

Thus if g is known for a particular material, the voltage output per unit stress can be calculated by knowing the value of t .

In order to relate the applied force to the generated charge the d constants are used. One of the d constants can be defined as :

$$d_{33} = \frac{\text{charge generated in direction 3}}{\text{force applied in direction 3}} = \frac{Q}{F} \dots (25.77)$$

Actually d_{33} can be calculated from g_{33} if the relative permittivity of the material is known. From Eqn. 25.78, we get

$$d_{33} = \epsilon_r \epsilon_0 g_{33} \dots (25.78)$$

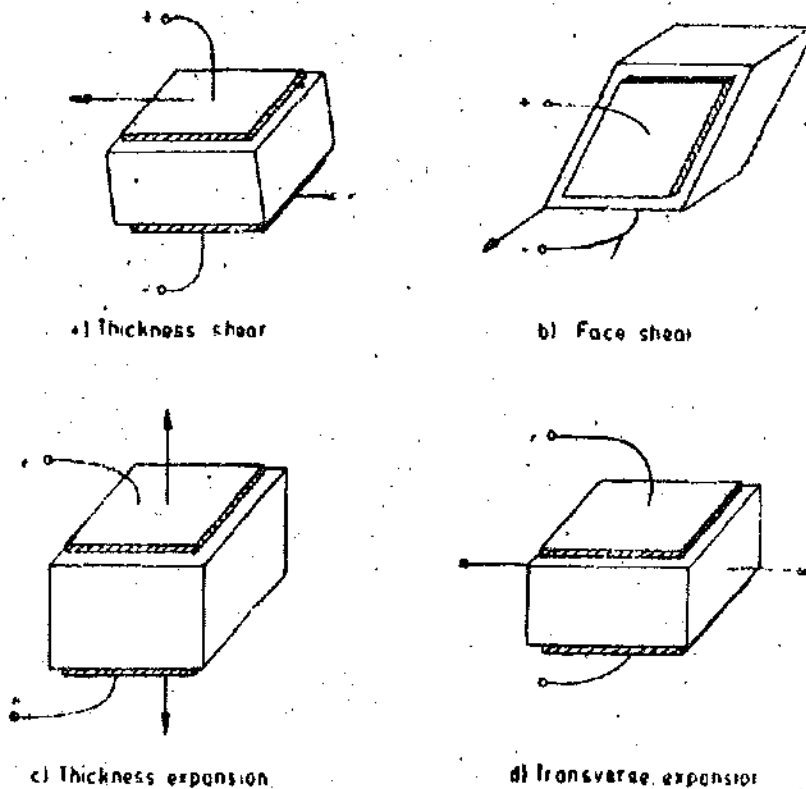

Fig. 25.62. Modes of operation of piezo-electric crystals.

When dealing with quartz, subscripts 11 are used because in quartz the thickness—expansion mode is along the crystallographic axis conventionally called axis 1.

The piezo-electric transducer is cut from a larger crystal in the direction of any of the electrical or mechanical axes perpendicular to the optical or crystal axis. The values of d and g are not necessarily the same but are dependent upon the axis of cut.

25'31.1. Modes of Operation of Piezo-electric Crystals. The piezo-electric crystals are used in many modes. These modes are :

(i) Thickness shear, (ii) Face shear, (iii) Thickness expansion and, (iv) Transverse expansion.

These modes are shown in Fig. 25'62.

By cementing two crystals together so that their electrical axes are perpendicular, 'benders' or 'twisters' can be produced (See Fig 25'63). This means that a bending motion applied to a bender produces an output voltage. Similarly a twisting motion applied to a twister produces an output.



(a) Crystal twister "bimorph".

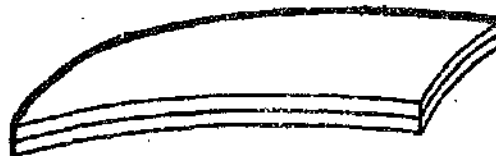

(b) Ceramic bender "bimorph" or "multimorph".

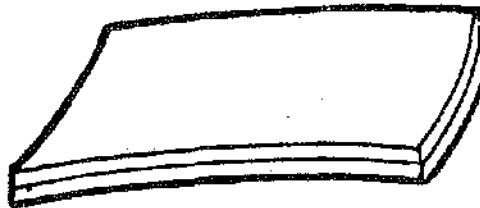

(c) Crystal bender "bimorph".

Fig. 25'63. Curvature of "twister" and "bender" piezo-electric transducers when voltage is applied.

Piezo-electric crystals can be used in another mode for force measurement. A crystal controlled electronic oscillator uses a thin plate of quartz. The natural frequency of mechanical oscillation of the plate determines the frequency of electrical oscillation.

25'31.2. Properties of Piezo-electric Crystal. The desirable properties of piezo-electric materials are stability, high output insensitivity to temperature and humidity, and the ability to be formed into most desirable shape.

Quartz is the most stable piezo-electric material. However, its output is quite small. On the other hand Rochelle salt provides the highest output but it can be worked over a limited humidity range and has to be protected against moisture. The highest temperature is limited to 45°C.

Barium titanate has the advantage that it can be formed into a variety of shapes and sizes since it is polycrystalline. It has also a higher dielectric constant. Natural crystals possess the advantages that they have higher mechanical and thermal stability, can withstand higher stresses, have low leakage (their volume resistivity is about $10^{16} \Omega\text{-m}$) and have a good frequency response. The synthetic materials, in general, have a higher voltage sensitivity.

Example 25'29. A quartz piezo-electric crystal having a thickness of 2 mm and voltage sensitivity of 0.055 V—m/N is subjected to a pressure of 1.5 MN/m². Calculate the voltage output. If the permittivity of quartz is 40.6×10^{-12} F/m, calculate its charge sensitivity.

Solution. From Eqn. 25'70, voltage output $E_0 = g t P = 0.055 \times 2 \times 10^{-3} \times 1.5 \times 10^6 = 165$ V

Charge sensitivity $d = \epsilon_0 \epsilon_r g$ (See Eqn. 25'71)

$$= 40.6 \times 10^{-12} \times 0.055 = 2.23 \times 10^{-12} \text{ C/N} = 2.23 \text{ pC/N.}$$

Example 25'30. A piezo-electric crystal having dimensions of 5 mm × 5 mm × 1.5 mm and a voltage sensitivity of 0.055 V-m/N is used for force measurement. Calculate the force if the voltage developed is 100 V.

Solution. From Eqn. 25'70, the applied pressure is :

$$P = \frac{E_0}{g t} = \frac{100}{0.055 \times 1.5 \times 10^{-3}} \text{ N/m}^2 = 1.2 \text{ MN/m}^2$$

Force $F = PA = 1.2 \times 10^6 \times 5 \times 5 \times 10^{-6} = 30 \text{ N.}$

Example 25'31. A barium titanate pickup has the dimensions of 5 mm × 5 mm × 1.25 mm. The force acting on it is 5 N. The charge sensitivity of barium titanate is 150 pC/N and its permittivity is $12.5 \times 10^{-9} \text{ F/m.}$ If the Modulus of elasticity of barium titanate is $12 \times 10^{10} \text{ N/m}^2$, calculate the strain. Also calculate the charge and the capacitance

Solution. Area of plates $A = w l = 5 \times 5 \text{ mm}^2 = 25 \times 10^{-6} \text{ m}^2.$

Pressure $P = \frac{5}{25 \times 10^{-6}} \text{ N/m}^2 = 0.2 \text{ MN/m}^2.$

Voltage sensitivity $g = \frac{d}{\epsilon_0 \epsilon_r} = \frac{150 \times 10^{-2}}{12.5 \times 10^{-9}} = 12 \times 10^{-3} \text{ Vm/N.}$

Voltage generated $E_0 = g t P = 12 \times 10^{-3} \times 1.25 \times 10^{-3} \times 0.2 \times 10^6 = 3 \text{ V.}$

Strain $\epsilon = \frac{\Delta l}{l} = \frac{\text{stress}}{\text{Young's modulus}} = \frac{0.2 \times 10^6}{12 \times 10^{10}} = 0.0167 \text{ m/m.}$

Charge $Q = dF = 150 \times 10^{-12} \times 5 \text{ C} = 750 \text{ pC.}$

Capacitance $C_p = \frac{Q}{E_0} = \frac{750 \times 10^{-12}}{3} \text{ F} = 250 \text{ pF.}$

25'31.3. Equivalent Circuit of Piezo-electric Transducer. The basic equivalent circuit of a piezo-electric transducer is shown in Fig. 25'64 (a).

The source is a charge generator. The value of the charge is $Q = dF.$

The charge generated is across the capacitance, C_{cr} , of the crystal and its leakage resistance $R_{cr}.$

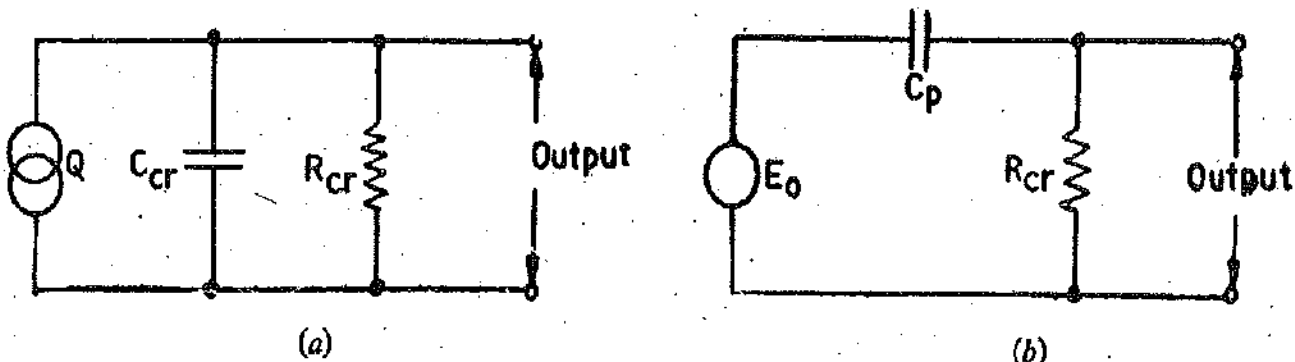

Fig. 25'64. Equivalent circuits of piezo-electric transducers.

The charge generator can be replaced by an equivalent voltage source having a voltage of

$$E_0 = \frac{Q}{C_{cr}} = \frac{dF}{C_{cr}} \quad \dots (25'79)$$

in series with a capacitance, C_{cr} , and resistance, R_{cr} , as shown in Fig. 25'63 (a).

The value of resistance R_{cr} is very large. It is of the order of $0.1 \times 10^{12} \Omega$ and thus the

equivalent circuit of the transducer is reduced to a voltage source of voltage E_0 in series with a series capacitance C_{cr} as shown in Fig. 25'64 (b). Under no load conditions, the voltage appearing across the terminals of the transducer is E_0 .

25'31.4. Loading Effects and Frequency Response. Let the transducer be loaded by a capacitance C_L and a resistance R_L . The capacitance C_L is the combination of the capacitance of the load, the capacitance of the cable and the stray capacitance. The diagram showing the load connected to a piezo-electric transducer is given in Fig. 25'65. This diagram is based upon the assumption that the resistance of the load, R_L , is very small as compared with the leakage resistance of the transducer R_{cr} , i.e., $R_L \ll R_{cr}$.

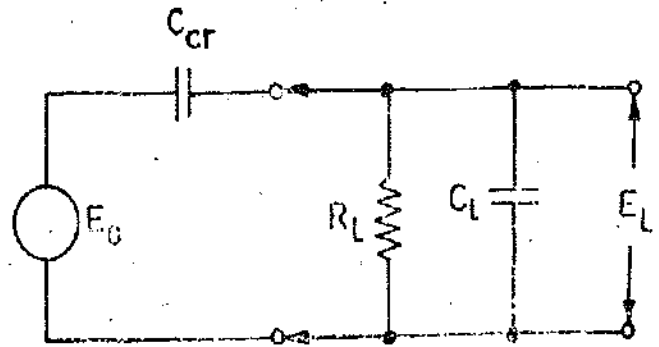

Fig. 25'65. Circuit of a Piezo-electric transducer under conditions of load.

$$\text{Impedance of load } Z_L = \frac{R_L}{1 + j\omega C_L R_L}$$

$$\text{Total impedance of circuit } Z_t = \frac{1}{j\omega C_{cr}} + \frac{R_L}{1 + j\omega C_L R_L} = \frac{1 + j\omega R_L (C_{cr} + C_L)}{(j\omega C_{cr})(1 + j\omega C_L R_L)}$$

Hence, the voltage across the load

$$E_L = \frac{Z_L}{Z_t} \times E_0 = \frac{R_L}{(1 + j\omega C_L R_L)} \times \frac{(j\omega C_{cr})(1 + j\omega C_{cr} R_L)}{1 + j\omega R_L (C_{cr} + C_L)} E_0$$

$$= \left[\frac{j\omega C_{cr} R_L}{1 + j\omega (C_{cr} + C_L) R_L} \right] E_0$$

The magnitude of voltage across the load is :

$$E_L = \left[\frac{\omega C_{cr} R_L}{\sqrt{1 + \omega^2 (C_{cr} + C_L)^2 R_L^2}} \right] E_0 \quad \dots(25'80)$$

$$E_L = \frac{dF}{C_{cr}} \left[\frac{\omega C_{cr} R_L}{\sqrt{1 + \omega^2 (C_{cr} + C_L)^2 R_L^2}} \right] \text{ as } E_0 = \frac{dF}{C_{cr}}$$

$$= \frac{dFt}{\epsilon_0 \epsilon_r A} \left[\frac{\omega C_{cr} R_L}{\sqrt{1 + \omega^2 (C_{cr} + C_L)^2 R_L^2}} \right] \quad \dots(25'81)$$

$$\text{At medium and high frequencies } E_L = \frac{E_0}{C_{cr} + C_L} \quad \dots(25'82)$$

This means that at medium and high frequencies the output voltage is independent of frequency but is dependent upon the load capacitance C_L .

From Eqn. 25'80, it is clear that under steady state conditions i.e., when $\omega = 0$, the transducer does not provide any output. As far as the maximum frequency limit is concerned, it is imposed by the mechanical resonance of the piezo-electric crystal and its associated mountings.

The piezo-electric transducers are mainly used for measurement of displacement. They can be used for measurement of force, pressure or acceleration. These quantities when measured with piezo-electric transducers are first converted into displacement and the displacement is subsequently applied to these transducers to produce an output voltage. Hence the conversion of displacement into voltage by piezo-electric crystal is considered here.

For the purpose of analysis it is necessary to consider the transducer, the connecting cable and

the amplifier as a unit. The impedance of the transducer is very high and hence an amplifier with a high input impedance has to be used in order to avoid loading errors:

Fig. 25'66 (a) shows the complete set-up for measurement of displacement.

Charge produced $q = K_q x_t$ coulomb ...(25'83)

where K_q = sensitivity ; C/m, and x_t = displacement : m.

Fig. 25'66 (b) shows the equivalent circuit of the measurement set up

R_L = leakage resistance of transducer ; Ω , C_{cr} = capacitance of transducer ; F,

C_{cable} = capacitance of cable ; F, C_{amp} = capacitance of amplifier ; F,

R_{amp} = resistance of amplifier ; Ω .

The charge generator is converted into a current generator as shown in Fig. 25'66. (c). The capacitance connected across the current generator is C where :

$$C = C_{cr} + C_{cable} + C_{amp} \quad \dots(25'84)$$

$$\text{Resistance } R = \frac{R_{amp} R_L}{R_{amp} + R_L} \quad \dots(25'85)$$

Since the leakage resistance of transducer is very large (of the order of $10^{11} \Omega$), $R \approx R_{amp}$.

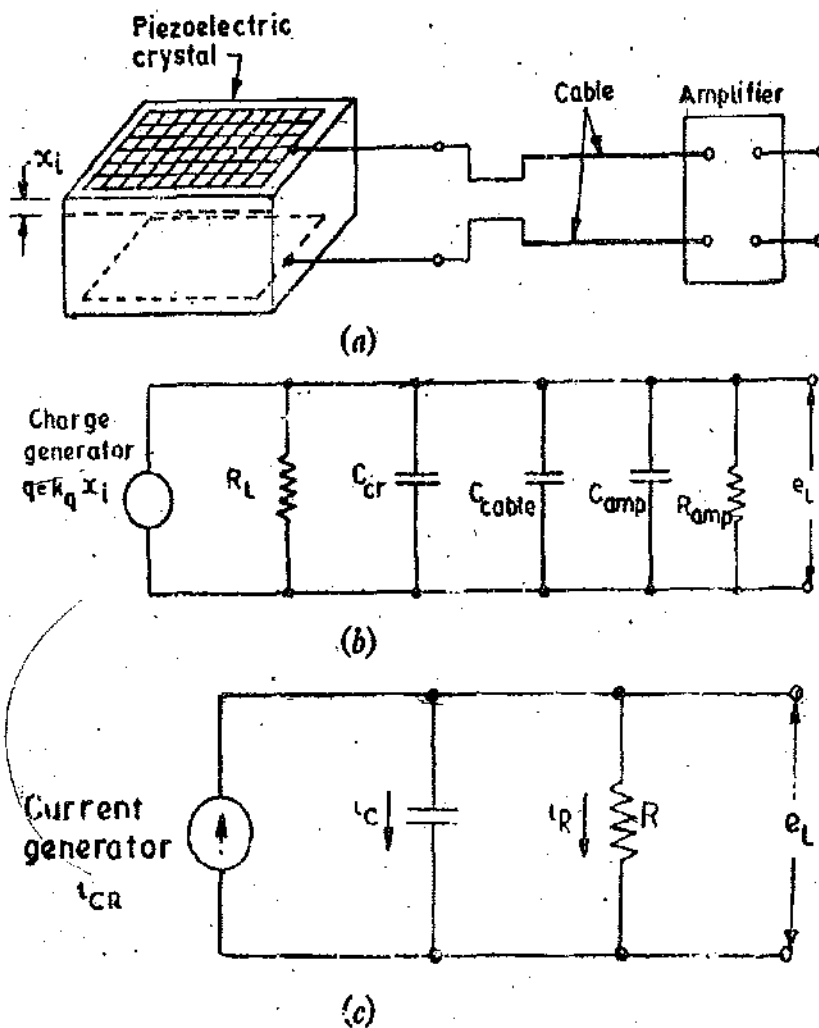

Fig. 25'66. Set-up of a piezo-electric transducer and its equivalent circuit.

Converting the charge generator into a current generator

$$i_{CR} = \frac{dq}{dt} = K_q \left(\frac{dx_t}{dt} \right) \quad \dots(25'86)$$

Now $i_{OR} = i_O - i_R$

∴ Output voltage at load $e_L = e_C = \frac{1}{C} \int i_O dt = \frac{1}{C} \int (i_{OR} - i_R) dt$

or $\frac{d(e_L)}{dt} = \frac{1}{C} (i_{OR} - i_R)$

or $C \frac{d(e_L)}{dt} = i_{OR} - i_R = K_d \frac{d(x_i)}{dt} - \frac{e_L}{R}$

or $R C \frac{d(e_L)}{dt} + e_L = K_d R \frac{d(x_i)}{dt}$... (25.87)

$\tau \frac{d(e_L)}{dt} + e_L = K \tau \frac{d(x_i)}{dt}$... (25.88)

where $K = \text{sensitivity} = \frac{K_d}{C} \text{ V/m}$... (25.89)

taking Laplace transform, we get: $(\tau s + 1) E_L(s) = K \tau s X_i(s)$

∴ Transfer function $\frac{E_L(s)}{X_i(s)} = \frac{K \tau s}{1 + \tau s}$... (25.90)

Sinusoidal transfer function $\frac{E_L}{X_i}(j\omega) = \frac{j\omega K \tau}{1 + j\omega \tau}$

The amplitude ratio is:

$M = \left| \frac{E_L}{K X_i}(j\omega) \right| = \frac{\omega \tau}{\sqrt{1 + (\omega^2 \tau^2)}} = \frac{1}{\sqrt{1 + (1/\omega \tau)^2}}$... (25.91)

The phase shift $\phi = \pi/2 - \tan^{-1} \omega \tau$ rad.

At high frequencies $\omega \gg 1$

∴ $M = 1$ and $\phi = 0$

Hence high frequency sensitivity is: $K = \frac{e_L}{x_i}$... (25.93)

Thus the frequency response of piezo-electric transducers is the same as that of capacitive transducers. This is shown in Fig. 25.56.

From Eqn. 25.91, we see that steady state response piezo-electric transducers to a constant displacement x_i is zero. Therefore, piezo-electric transducer cannot be used for measurement of static displacements.

25.31.5. Impulse Response of Piezo-electric Crystals. Let a displacement x_i be applied to the transducer:

where $x_i = A \quad 0 \leq t < T$ and $x_i = 0 \quad T < t < \infty$

The function is shown in Fig. 25.67 (a).

Therefore the charge is suddenly increased to $K_d A$ and the crystal voltage rises to $e_L = A/C$.

Thus the initial condition is $e_L = \frac{K_d A}{C}$ at $t = 0^+$.

From Eqns. 25.88 and 25.89 we have $\tau \frac{d(e_L)}{dt} + e_L = K \tau \frac{d(x_i)}{dt} = \frac{K_d}{C} \tau \frac{d(x_i)}{dt}$... (25.94)

Solving the differential equation with initial condition we get,

$e_L = \frac{K_d A}{C} e^{-t/\tau}$ for $0 \leq t < T$... (25.95)

For $T < t < \infty$, the value of $x_t = 0$ and hence the differential equation is :

$$\tau \frac{d(e_L)}{dt} + e_L = 0 \quad \dots(25'96)$$

At $t = T^-$, Eqn. 25'95 still holds good and therefore $e_L = \frac{K_q A}{C} e^{-t/\tau}$

Value of e_L at $t = T$ is : $e_L = \frac{K_q A}{C} e^{-T/\tau}$... (25'97)

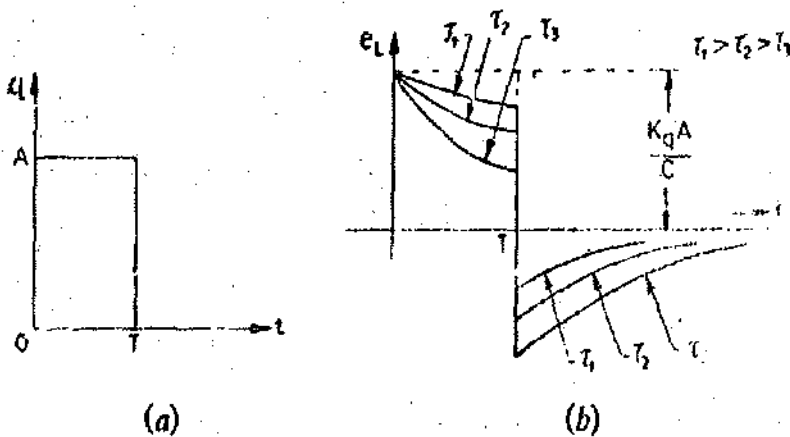

Fig. 25'67. Pulse response of piezoelectric transducer.

However, at $t = T$, x_t suddenly decreases by a value A . This causes a sudden decrease in charge by an amount $K_q A$ resulting in a sudden change of e_L by an amount $K_q A / C$ from its value at $t = T^-$. Hence at $t = T^+$, the value of e_L is :

$$e_L = \frac{K_q A}{C} e^{-T/\tau} - \frac{K_q A}{C} = \frac{K_q A}{C} (e^{-T/\tau} - 1) \quad \dots(25'98)$$

This becomes the initial condition for Eqn. 25'95. The solution is :

$$e_L = \frac{K_q A}{C} (e^{-T/\tau} - 1) e^{-(t-T)/\tau} \quad T < t < \infty \quad \dots(25'99)$$

Fig. 25'67 (b) shows the impulse response with three different time constants. In order to have faithful reproduction of input displacement x_t , the value of time constant τ should be large. If the decay and the under shoot is to be kept within say, 5 per cent of true value, τ should be at least 20 T .

25'31'6. Uses of Piezo-electric Materials and Transducers

The uses of piezo-electric materials and transducers are described below :

(i) The desirable properties expected out of a piezo-electric material are, stability, high output, insensitivity to temperature variations, insensitivity to variations in humidity and also the ability to be formed into a usable component. Undoubtedly the most stable material is quartz. However, its output is low. Rochelle salt, on the other hand provides, the highest output out of any of the piezo-electric materials. But it requires protection from moisture and hence cannot be used above a temperature of 45°C.

Because of its stability, quartz is commonly used for stabilizing electronic oscillators. The crystal is ground to proper shape and is connected in an appropriate electronic circuit whose frequency is controlled by it.

(ii) The use of piezo-electric transducer elements is confined primarily to dynamic measurements. The voltage developed by application of strain is not held under static conditions. Hence, the elements are primarily used in the measurement of such quantities as surface roughness and in accelerometers and vibration pickups.

(iii) Ultrasonic generator elements also use barium titanate, a piezo-electric material. Such elements are used in industrial cleansing apparatus and also in underwater detection system known as sonar.

Example 25'32. A piezo-electric quartz crystal has an area of 100 mm^2 and is 1 mm thick. It is held between two metal electrodes and is used for measurement of changes of force across the crystal. Young's modulus for the material is 90 GN/m^2 , the charge sensitivity is 2 pC/N , the relative permittivity is 5.

The resistivity is $10^{13} \Omega\text{m}$. A 20 pF capacitance and a resistance of $100 \text{ M}\Omega$ are connected in parallel across the electrodes. If a force $F_t = 0.01 \sin 1000 t$ newton is applied, find (a) peak to peak voltage swing across the electrodes under open circuit and under load conditions and (b) the maximum change in crystal thickness. [F_t is the instantaneous value of force F]. The permittivity of free space is 8.85 pF/m .

Solution. The rms value of voltage under open circuit $E_0 = \frac{d t}{\epsilon_r \epsilon_0} \frac{F}{A}$ (See Eqn. 25'68)

\therefore Maximum value of voltage under open circuit $E_{0 \text{ max}} = \sqrt{2} \frac{d t}{\epsilon_r \epsilon_0} \frac{F}{A} = \frac{d t}{\epsilon_r \epsilon_0} \frac{F_{\text{max}}}{A}$

as maximum value of force $F_{\text{max}} = \sqrt{2} F$.

Hence, peak to peak value of voltage under open circuit :

$$E_0 (\text{peak to peak}) = 2 E_{0 \text{ max}} = 2 \frac{d t}{\epsilon_r \epsilon_0} \frac{F_{\text{max}}}{A}$$

$$= 2 \times \frac{2 \times 10^{-12} \times 1 \times 10^{-3}}{5 \times 8.85 \times 10^{-12}} \times \frac{0.01}{100 \times 10^{-6}} = 9.03 \times 10^{-3} \text{ V} = 9.3 \text{ mV.}$$

$$\text{Leakage resistance of crystal } R_{cr} = \frac{\rho l}{A} = 10^{13} \times \frac{1 \times 10^{-3}}{100 \times 10^{-6}} = 10 \times 10^{12} \Omega.$$

$$\text{Load resistance } R_L = 100 \text{ M}\Omega = 100 \times 10^6 \Omega.$$

Hence the resistance of the crystal is very large as compared with resistance of load i.e.

$R_{cr} \gg R_L$ and therefore we can neglect R_{cr} .

$$\text{Capacitance of crystal } C_{cr} = \frac{\epsilon_r \epsilon_0 A}{d} = \frac{5 \times 8.85 \times 10^{-12} \times 100 \times 10^{-6}}{1 \times 10^{-3}} = 4.43 \times 10^{-12} \text{ F.}$$

The peak to peak output voltage under load conditions is :

$$E_L (\text{peak to peak}) = \frac{2d F_{\text{max}}}{\epsilon_r \epsilon_0 A} \left[\frac{\omega C_{cr} R_L}{\sqrt{1 + \omega^2 (C_{cr} + C_L)^2 R_L^2}} \right]$$

$$E_L (\text{peak to peak}) = \frac{2 \times 2 \times 10^{-12} \times 0.01}{5 \times 8.85 \times 10^{-12} \times 100 \times 10^{-6}}$$

$$\left[\frac{1000 \times 4.43 \times 10^{-12} \times 100 \times 10^6}{\sqrt{1 + (1000)^2 \times (4.43 + 20)^2 \times (10^{-12})^2 \times (100 \times 10^6)^2}} \right] = 1.58 \text{ mV.}$$

This means that the output signal is attenuated to a great extent due to loading.

From Eqn. 25'65, the maximum value of change in thickness is :

$$\Delta t = \frac{F_{\text{max}} t}{AE} = \frac{0.01 \times 1 \times 10^{-3}}{100 \times 10^{-6} \times 90 \times 10^9} = 1.1 \times 10^{-12} \text{ m.}$$

$\therefore \Delta t (\text{peak to peak}) = 2 \times 1.1 \times 10^{-12} = 2.2 \times 10^{-12} \text{ m.}$

Example 25.33. In a piezoelectric transducer a flat frequency response within 5% is required. Find the value of minimum frequency in terms of time constant for which it can be used. If the time constant of the transducer is 1.5 ms, find the value of minimum frequency. Find the phase shift at this frequency.

Solution. In order to obtain a flat response within 5%, the amplitude ratio should be :

$$M = 1 - 0.05 = 0.95$$

Now
$$M = \frac{1}{\sqrt{1+(1/\omega\tau)^2}} \text{ or } 0.95 = \frac{1}{\sqrt{1+(1/\omega\tau)^2}} \text{ or } \omega\tau = 3.04$$

\therefore Minimum value of frequency
$$\omega = \frac{3.04}{\tau} = \frac{3.04}{1.5 \times 10^{-3}} = 2.02 \times 10^3 \text{ rad/s.}$$

Phase shift
$$\phi = \pi/2 - \tan^{-1} \omega\tau \text{ rad.} = 90^\circ - \tan^{-1} 3.04 = 90^\circ - 71.8^\circ = 18.2^\circ.$$

Example 25.34. A piezo-electric transducer has a capacitance of 1000 pF and a charge sensitivity of $40 \times 10^{-3} \text{ C/m}$. The connecting cable has a capacitance of 300 pF while the oscilloscope used for readout has a readout input resistance of 1 M Ω with a paralleled capacitance of 50 pF.

- (a) What is the sensitivity (V/m) of the transducer alone ?
- (b) What is the high frequency sensitivity (V/m) of the entire measuring system ?
- (c) What is the lowest frequency that can be measured with 5 per cent amplitude error by the entire system ?
- (d) What is the value of an external shunt capacitance that can be connected in order to extend the range of 5 per cent error down to 10 Hz?
- (e) With external capacitance calculated in (d) connected in the circuit, what is the system high frequency sensitivity ?

Solution :

(a) Charge sensitivity of transducer $K_q = 40 \times 10^{-3} \text{ C/m}$.

Capacitance of transducer $C_{tr} = 1000 \times 10^{-12} \text{ F}$

\therefore Sensitivity of transducer
$$K = \frac{K_q}{C_{tr}} = \frac{40 \times 10^{-3}}{1000 \times 10^{-12}} = 40 \times 10^6 \text{ V/m.}$$

(b) The total capacitance of the measuring circuit

$$C = C_{tr} + C_{cable} + C_{osc} = 1000 + 300 + 50 = 1350 \text{ pF.}$$

\therefore High frequency sensitivity of entire system
$$= \frac{K_q}{C} = \frac{40 \times 10^{-3}}{1350 \times 10^{-12}} = 29.63 \times 10^6 \text{ V/m.}$$

(c) Time constant of system $\tau = RC = 1 \times 10^6 \times 1350 \times 10^{-12} \text{ s} = 1.35 \text{ ms.}$

The lowest frequency can be used for 5 percent magnitude error can be found as under

$$0.95 = \frac{1}{\sqrt{1+(1/\omega\tau)^2}} \text{ or } \omega\tau = 3.04$$

or
$$\omega = \frac{3.04}{1.35 \times 10^{-3}} = 2254 \text{ rad/s.}$$

\therefore Minimum frequency that can be used with 5% error
$$f = \frac{2254}{2\pi} = 358.7 \text{ Hz.}$$

(d) It is now required that a frequency of 10 Hz be measured with 5% error.

$$\therefore \text{Time constant } \tau = \frac{3.04}{\omega} = \frac{3.04}{2\pi \times 10} = 48.38 \times 10^{-3} \text{ s.}$$

$$\text{Total capacitance } C = \frac{48.38 \times 10^{-3}}{1 \times 10^6} \text{ F} = 48.380 \text{ pF.}$$

$$\therefore \text{External capacitance required } C_e = 48380 - 1350 = 47030 \text{ pF.}$$

$$(e) \text{ High frequency sensitivity with external capacitance} = \frac{40 \times 10^{-3}}{48380 \times 10^{-12}} \text{ V/m} = 827 \text{ kV/m.}$$

Example 25'35. A piezo-electric transducer has a capacitance of 2000 pF and a charge sensitivity of 100×10^{-12} C/N. The resistance of transducer is $10^6 \text{ M}\Omega$ and the impedance of the measuring system consists of a capacitance of 500 pF in parallel with a resistance of $1 \text{ M}\Omega$. Find the response if the applied force is :

$$F = 0.1 \text{ N for } 0 < t < 2 \text{ ms, and } F = 0 \text{ N for } 2 \text{ ms} < t < \infty.$$

Find the value of voltage just before and just after the impulse is terminated. Also find the voltage after 10 ms of application of the pulse.

Solution. The leakage resistance of the transducer is very large as compared with the resistance of the measuring system.

$$\therefore R = 1 \text{ M}\Omega = 10^6 \Omega.$$

$$\text{The capacitance of the system } C = C_{tr} + C_{cable} + C_{amp} = 2000 + 500 = 2500 \text{ pF.}$$

$$\text{Time constant of circuit } \tau = RC = 10^6 \times 2500 \times 10^{-12} = 2.5 \times 10^{-3} \text{ s} = 2.5 \text{ ms.}$$

$$\begin{aligned} \text{Voltage across the load } e_L &= \frac{dF}{C} e^{-t/\tau} = \frac{100 \times 10^{-12}}{2500 \times 10^{-12}} \times 0.1 e^{-t/2.5 \times 10^{-3}} \\ &= 4 \times 10^{-3} e^{-400 t} \text{ for } 0 < t < 2 \text{ ms.} \end{aligned}$$

$$\text{At } t = 2 \text{ ms, } e_L = 4 \times 10^{-3} e^{-400 \times 2 \times 10^{-3}} = 1.8 \times 10^{-3} \text{ V} = 1.8 \text{ V.}$$

This is voltage at just before $t = 2 \text{ ms}$.

$$\begin{aligned} \text{The voltage output just after } 2 \text{ ms: } e_L &= \frac{dF}{C} \left(e^{-t/\tau} - 1 \right) \\ &= \frac{100 \times 10^{-12} \times 0.1}{2500 \times 10^{-12}} \left(e^{-2 \times 10^{-3}/2.5 \times 10^{-3}} - 1 \right) \\ &= 4 \times 10^{-3} \times (0.55) = -2.2 \times 10^{-3} \text{ V} = -2.2 \text{ mV.} \end{aligned}$$

$$\begin{aligned} \text{The voltage output beyond } 2 \text{ ms is given by: } e_L &= \frac{dF}{C} \left(e^{-T/\tau} - 1 \right) e^{-(t-T)/\tau} \\ &= \frac{100 \times 10^{-12} \times 0.1}{2500 \times 10^{-12}} \left(e^{-2 \times 10^{-3}/2.5 \times 10^{-3}} - 1 \right) e^{-(t-2 \times 10^{-3})/(2.5 \times 10^{-3})} \\ &= -2.2 \times 10^{-3} e^{-(400 t - 0.8)} \text{ V for } 2 \text{ ms} < t < \infty. \end{aligned}$$

Voltage after 10 ms of application of pulse :

$$= -2.2 \times 10^{-3} e^{-(400 \times 10 \times 10^{-3} - 0.8)} = -0.09 \times 10^{-3} \text{ V} = -0.09 \text{ mV.}$$

Example 25'36. A pulse is applied to a piezo-electric transducer for a time T . Prove that in order to keep the undershoot to a value within 5%, the value of time constant should be approximately $20 T$.

Solution. The value of voltage at $t=T$ is given by : $e_L = \frac{K_q A}{C} e^{-T/\tau}$

The voltage reduces by a factor $e^{-T/\tau}$ from its value at $t=0$.

For 5% undershoot, the value of voltage at $t=T$ should be 0.95 of its initial value

$\therefore 0.95 = e^{-T/\tau}$ or $T/\tau = 0.0513$ or $\tau = 19.5 T$.

Therefore in order to keep the undershoot to 5% within its initial value $\tau \approx 20 T$.

25.32. Optical transducers. These transducers have been explained in chapter 19 page 626.

25.33. Hall effect transducers. These transducers have been explained in chapter 18 page 600

25.34. Ionization Transducers. An ionization transducer consists of a glass envelope with two internal electrodes and filled with gas or gases under reduced pressure.

Fig. 25.68 (a) shows an ionization transducer used for measurement of displacements upto about 1 mm. The tube is filled with a gas at 10 mm of mercury and is placed between two external electrodes connected to a radio frequency (R.F.) power generator. A high frequency electric field is produced between the electrodes. In case, the field is sufficiently strong, the gas is ionized and a glow discharge occurs. The two internal electrodes act as probes in the discharge. Their potential is determined by the space potential of the plasma surrounding each electrode and by the R.F. potential induced by their capacitive coupling to the external electrodes. When the internal electrodes are symmetrically placed between the external electrodes, the potential between them is zero and hence there is no output. However, any deviation from this central position produces a d.c. voltage E_0 , between the inner electrodes. The polarity of this voltage reverses as the tube passes through the

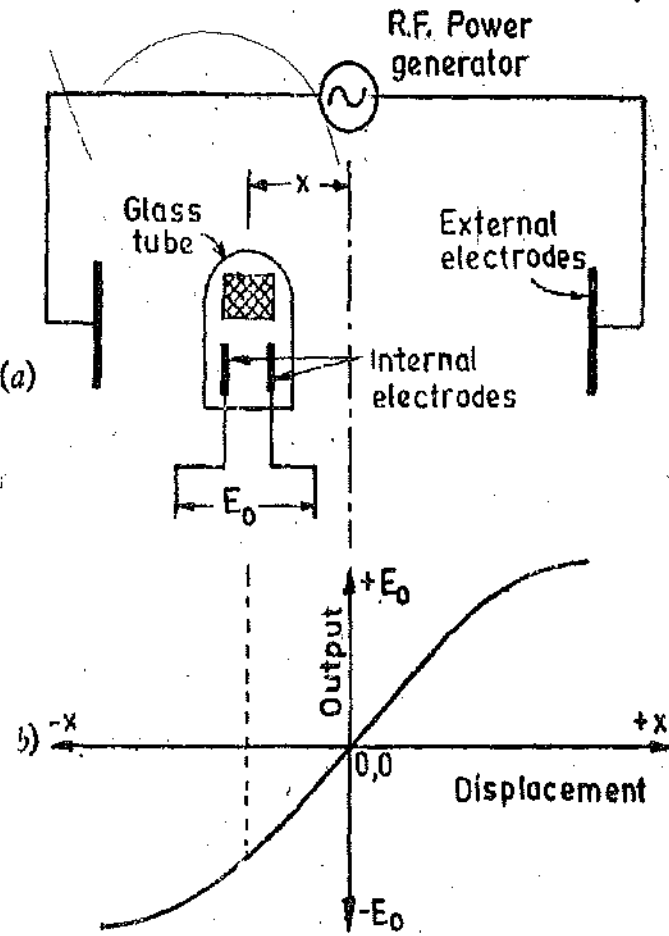

Fig. 25.68. Ionization gauge and input-output relationships.

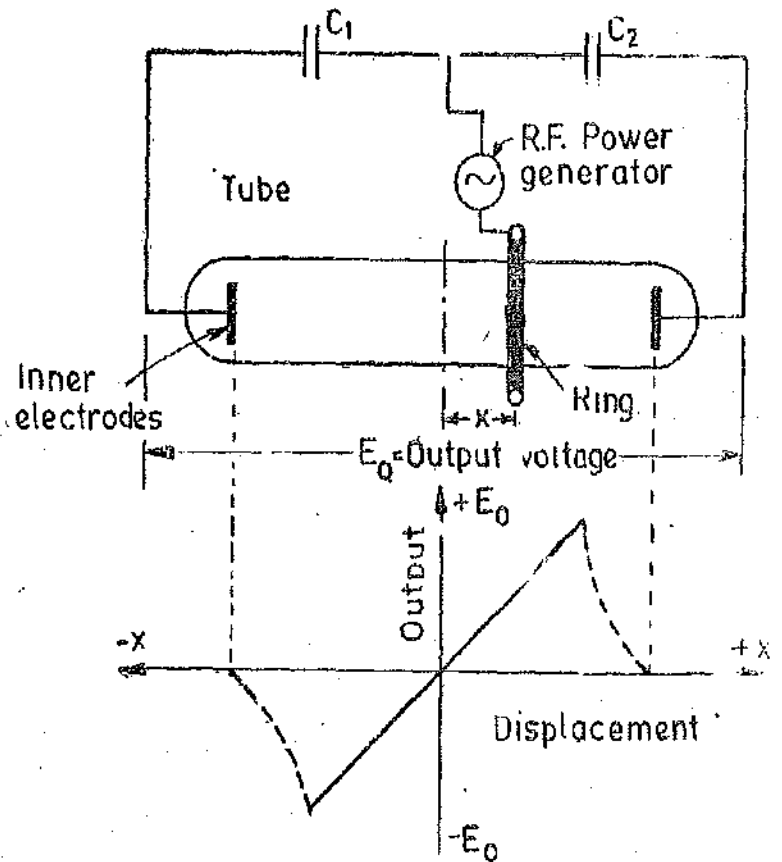

Fig. 25.69. Modified ionization transducer for measurement of large displacements

midpoint. There exists a linear relationship between output voltage and displacement over a large range as shown in Fig. 25'68 (b).

When measuring large displacements upto about 500 mm, a different arrangement is used as shown in Fig. 25'69.

The R.F. source is connected between earth and a movable metal ring placed over the tube. The two electrodes in the tube are connected to earth via capacitors C_1 and C_2 . A discharge takes place between the ring and each electrode. Any asymmetry in the position of the ring causes a d.c. voltage to appear across the electrodes. This voltage varies linearly with displacement of the ring over a large range. The sensitivity is between 1 to 10 V/mm.

25'35. Digital Transducer. The use of digital transducers is on the increase. Fig. 25'19 on page 773 shows a digital linear displacement transducer. The use of digital code makes it possible to identify the position of a movable test piece by binary system of notation. The position is given as a train of digital pulses. A digital displacement transducer is called an Encoder.

Since the binary system uses only two symbols 0 and 1, it can be easily represented by two different types of systems using optical methods or using electrical methods. The digital transducers using optical methods are called **Optical Encoders** while those using electrical methods are called **Resistive Electrical Encoders**.

1. Optical Encoders. A sector (Fig. 25'70) may be designed with a pattern of opaque and translucent areas. A photo-electric sensor and a light source is placed on the two sides of the sector. The displacement is applied to the sector and therefore changes the amount of light falling on the photo-electric sensor. The pattern of illuminated sensor then carries the information as to the location of the sector. Fig. 25'70 shows a possible sector or pattern of opaque and translucent areas. The number of levels in the encoder determines the accuracy with which device operates.

A sector (Fig. 25'70) may be designed with a pattern of opaque and

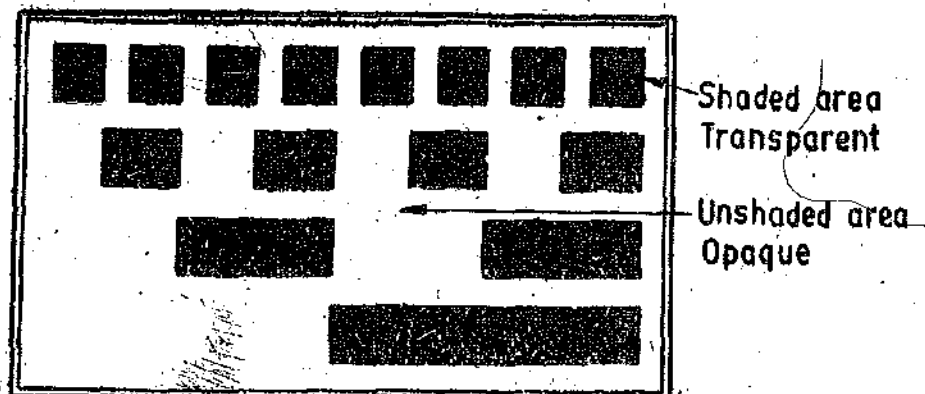

Fig. 25'70. Pattern of translucent and opaque sectors used in optical encoders.

Advantages and Disadvantages. These encoders have two major advantages :

(i) They give a true digital readout. (ii) No mechanical contact is involved and therefore problems of wear and alignment are not present.

The disadvantage is that the lights burn out. However, the life of the lamps is about 50,000 hours.

2. Resistive Digital Encoders. There is another way in which this pattern (Fig. 25'70) may be used. The shaded areas are made of conducting material and the unshaded areas of insulating materials. Sliding contacts are used which make contacts. The circuits of sliding contacts, which come in contact with conducting areas are completed and the circuits of the others which make contacts with insulated areas are not completed. Thus the encoder gives a digital readout which is an indication of the position of the device and hence this encoder determines the displacement.

Advantages and Disadvantages. The advantages of this type of encoder are :

(i) It is relatively inexpensive. (ii) It can be made to any degree of desired accuracy provided that the sector is made large enough to accommodate the required number of rows for binary numbers, and are quite adequate for slowly moving systems.

The disadvantages are :

(i) The major problem with the use of these encoders is on account of wear of contactors and maintenance of the contacts. (ii) There is often an ambiguity of one digit in the least significant binary digit.

The resolution of digital transducers depends upon the number of digits comprising the binary number. The resolution is $1/2^n$ of full scale where n is the number of digits.

The range is up to several metres with an accuracy of 1 part in 20,000 of full scale. The accuracy obviously depends on the accuracy with which the scale is drawn.

25.36. Shaft Encoder. A shaft encoder is a digital device used for measurement of angular position. An increasing number of measuring instruments are being used to communicate with a digital computer for measurement and control applications. The amount of raw data generated by large scale test programmes is so great that automated computer reduction of these data in meaningful form becomes a necessity. In addition, the feedback control systems for complex processes are becoming increasingly dependent on digital computer for part or complete action of computers for generation of control action. Therefore, there is a necessity of measuring devices that form a basic part of these systems whose output is compatible with digital nature of the computer. In practice, there are two forms of generation of digital signals. The first form converts the analogue variable to a shaft rotation (or translation in linear measurements) and then using many types of shaft angle encoder to generate digital voltage signals. The second approach is to convert the analogue variable to an analogue voltage which is then converted to a digital voltage by one of many voltage to digital converters as given in Chapter 26. The shaft angle encoder and voltage to digital converter are perhaps the most close approaches to true digital transducers, the first being for motion and the second for voltage. Here we consider the shaft angle encoder for transducing the analogue motion to digital voltage.

In order to understand the operation of a shaft encoder, we should first consider a translational encoder (a linear displacement digital transducer as given earlier) is shown in Fig. 25.71. The encoder shown has four tracks (bits) and is divided into conducting and insulating portions, with the smallest increment being 0.01 mm. As the scale moves under the brushes, the respective lamp circuits are made or broken so that the numbers shown on the readout lamps is at every instant equal to one hundredth of a mm.

For angular displacements, the pattern given in Fig. 25.70 is simply deformed so that the length of the scale becomes the circumference of a circle on a flat disc. The brushes are then placed along a radial line on the disc Fig. 25.72 shows the disc.

The disc is divided into concentric circular tracks and each of these is then divided into segments in a manner depending upon the code being used. For pure binary code, the inner track is halved, the next quartered and the next divided into 8 parts and so on. Each track has twice as many segments as the adjacent one near the centre. The detection method determines the treatment of the disc. The alternate segments on each track are made transparent and opaque, if transmitted light and photocells are used. If the segments are made reflecting and non-reflecting, reflected light and photo cells are used. Electrical methods are used for detection in case the segments are made conducting and non-conducting alternatively.

Thus if the scale is scanned radially a binary 0 or 1 is obtained from each track depending upon the angular position of the disc. Each position of the disc, provided the resolution angle is exceeded between positions, gives a unique number comprising the same number of digits as there are tracks on the disc.

The accuracy depends upon the number of tracks and if there are n tracks, the accuracy obtained is ; $\frac{360^\circ}{2^{10}} = 10$ second.

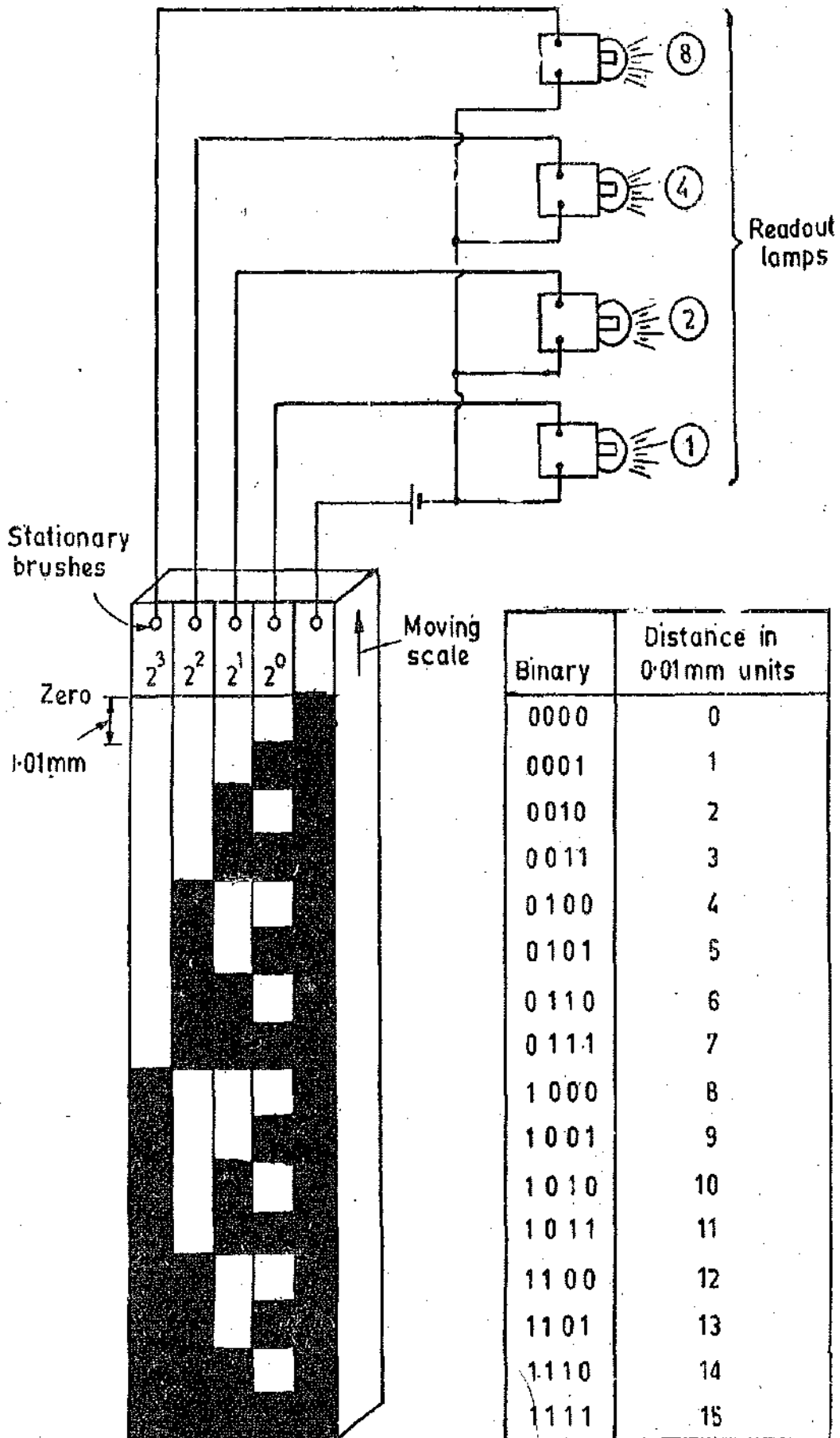

Fig. 25.71. Digital transducer.

Such discs are manufactured with diameters from 5 to 25 cm and give unique codes for between 100 and 50,000 positions per 360°. The sequence and order of indications represent the position of the shaft in the coded form. Fig. 25.73 shows two discs one using binary and other using cyclic code.

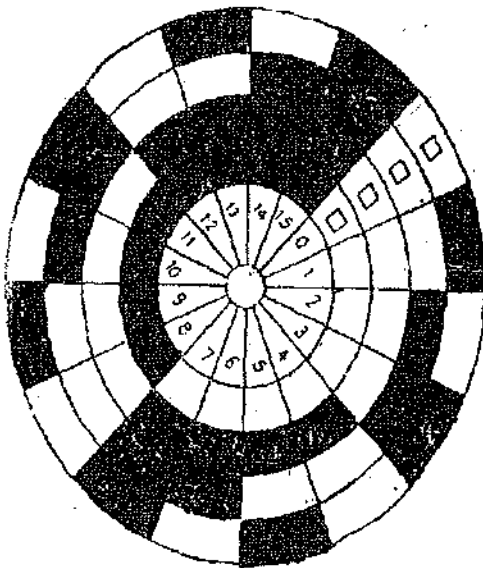
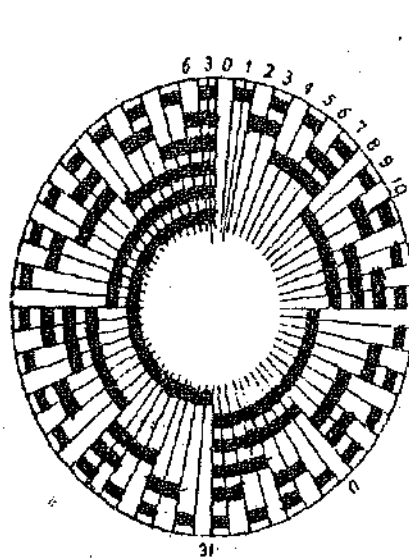
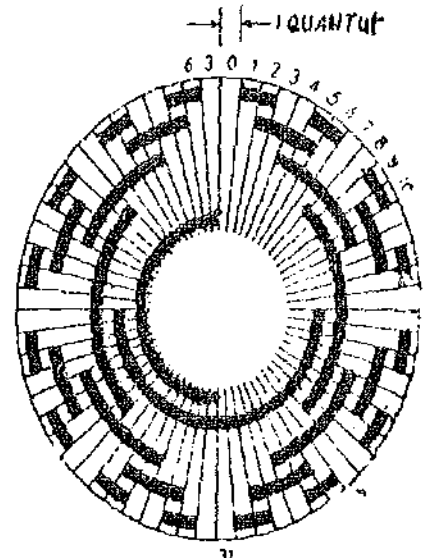

Fig. 25.72. Digital Shaft Encoder.



STRAIGHT BINARY CODE

(a)



CYCLIC BINARY CODE

(b)

Fig. 25.73. Shaft Encoders using straight binary and cyclic binary codes.

UNSOLVED PROBLEMS

1. A steel diaphragm is used for pressure measurement. It is 50 mm in diameter, and is to be designed to measure a maximum pressure of 1.5 MN/m². The modulus of elasticity of steel is 200 GN/m² and Poisson's ratio is 0.3. Calculate the thickness of diaphragm in order that the maximum deflection is not more than 1/3 of its thickness. Calculate the natural frequency of diaphragm. The density of steel is 7800 kg/m³. [Ans. 1.1 mm, 26,600 Hz]
2. A torsion bar is made of mild steel and has a diameter of 25 mm. The shear modulus of mild steel is 80 GN/m². Calculate the value of shear sensitivity. Suppose a torque of 10 × 10³ Nm is applied to the bar, calculate the value of shear strain angle.
If the bar is notched to 15 mm diameter, what is the value of shear sensitivity and the shear angle for the above torque. [Ans. 4 × 10⁻⁶ rad/Nm, 0.04 rad ; 18.8 × 10⁻⁶ rad/Nm, 0.188 rad]
3. A 5000 Ω voltage dividing potentiometer feeds a load of 8000 Ω. Calculate the percentage error based upon full scale for slider positions at 0, 0.2, 0.4, 0.6, 0.8 and 1.0 p.u. of the total travel. Plot the graph between p.u. travel and percentage error. [Ans. Percentage error : 0, 1.8, 5.2, 7.8, 7.2, 0]
4. A potentiometer has a resistance of 5000 Ω and is rated at 3 W. What is the maximum allowable excitation voltage?
Calculate the value of the sensitivity and resolution if the length of potentiometer is 0.1 m and there are 200 turns. Also calculate the percentage loading error at 0.67 of the travel if a meter of 5000 Ω is connected across the pot. [Ans. 122 V, 12.2 V/mm, 0.61 V, -12.1%]
5. A voltage dividing potentiometer is used to measure an angular displacement. The angle of displacement is 60° and total angle of travel of potentiometer is 355°. Calculate the voltage output on open circuit if the potentiometer is excited by a 60 V source. Calculate the actual value of the output voltage at this setting if a voltmeter of 1 MΩ resistance is connected across the output. The resistance of the potentiometer is 1 kΩ. The turns are uniformly distributed. Calculate the percentage error. [Ans. 10.14 V, 10.1386 V, -0.014%]
6. Find the strain that results from a tensile force of 1000 N applied to a 10 m long aluminium bar having cross-sectional area of 4 × 10⁻⁴ m². The modulus of elasticity of aluminium is 69 GN/m². [Ans. 38.23 microstrain]
7. A resistance wire strain gauge having a nominal resistance of 350 Ω is subjected to a strain of 500 micro-strain. Find the change in the value of resistance neglecting the piezoresistive effect. [Ans. 0.35 Ω]
8. Compare the resistance change produced by a strain of 150 microstrain if a strain gauge of nominal resistance of 120 Ω is used (i) when made of wire resistance having a gauge factor of 2.13, and (ii) when made of a semiconducting material having a gauge factor of 151. [Ans. (i) 0.03834 Ω, (ii) 2.718 Ω]

9. A strain gauge has a gauge factor of 4. If the strain gauge is attached to a metal bar that stretches from 0.25 m to 0.255 m when strained, what is the percentage change in resistance? If the unstrained value is 120 Ω , what is the resistance value after application of strain? [Ans. 8%, 129.6 Ω]

10. A metallic strain gauge has a resistance of 120 Ω and a gauge factor of 2. It is installed on an aluminium structure which has a yield point stress of 0.2 GN/m² and Young's modulus of 68.7 GN/m², determine the change in resistance of the gauge that would be caused by loading the material to its yield point. [Ans. 0.7 Ω]

11. A semiconductor gauge having a resistance of 1000 Ω and a gauge factor of -133 is subjected to a compressive strain of 500 microstrain. Calculate the new value of resistance of the gauge. [Ans. 1066.5 Ω]

12. A platinum resistance thermometer has a resistance of 150 Ω at 0°C. What is the resistance when the temperature is 200°C? When the thermometer has a resistance of 400 Ω , what is the value of the temperature? The resistance temperature co-efficient of platinum is 0.0039 $\Omega/\Omega-^{\circ}\text{C}$. [Ans. 170.25 Ω , 427°C]

13. The following table gives the variation of resistance with temperature.

Temperature $^{\circ}\text{C}$	15	18	21	24	26.5	29.5	33
Resistance Ω	106.06	107.14	108.22	109.3	110.38	111.46	112.75

Find the linear and quadratic approximation of the above resistance temperature curve for temperature variations between 15°C and 33°C about a temperature of 24°C.

[Ans. $R_{\theta} = 109.3 [1 + 3.41 \times 10^{-3} (\theta - 24)]$, $R_{\theta} = 109.3 [1 + 3.55 \times 10^{-3} (\theta - 24) - 0.66 \times 10^{-5} (\theta - 24)^2]$

14. The resistance temperature relationship for a thermistor is given by:

$$R_{T_2} = R_{T_1} \exp \beta (1/T_2 - 1/T_1)$$

If the value of β is 4000 K and the resistance of thermistor is 200 k Ω at -100°C find the value of resistance at 40°C. Find the ratio of two resistances. Find the ratio of two resistances for platinum over the same temperature.

Platinum has a resistance temperature co-efficient of 0.0039 $\Omega/\Omega-^{\circ}\text{C}$. [Ans. $6.93 \times 10^{-3} \Omega$, 28.8×10^4 , 2.95]

15. A thermistor may be assumed to have a linear temperature resistance over a limited temperature range. The variation in resistance is -0.05/ $^{\circ}\text{C}$ rise of temperature. The thermistor has a resistance of 1000 Ω at 20°C. Calculate the value of its resistance at 25°C. Supposing this thermistor is used in series with a copper coil, what is the value of the resistance of copper coil if the resistance at 20°C and 25°C is the same for the series connected circuit comprising of coil and the thermistor? The resistance temperature co-efficient of copper may be assumed as 0.004/ $^{\circ}\text{C}$. [Ans. 750 Ω , 12.5 k Ω]

16. An LVDT has an output of 6 V rms when the displacement is 0.4×10^{-3} mm. Determine the sensitivity of this instrument in V/mm. A 10 V voltmeter with 100 scale divisions is used to read the output. Two tenths of a division can be estimated with ease. Determine the resolution of the voltmeter.

The above arrangement is used in a pressure transducer for measuring the deflection of a diaphragm. The diaphragm is deflected through 0.5×10^{-3} mm by a pressure of 1000 N/m². Determine the sensitivity and resolution of this instrument. [Ans. 15000 V/mm, 0.02 V, 7.5 m V/N-m⁻², 2.67 Nm]

17. A parallel plate capacitive transducer has plates of 600 mm² area which are separated by air by a distance of 0.2 mm. The resistance of the transducer is $0.0 \times 10^{12} \Omega$. Calculate the time constant of the transducer and find the attenuation of the output at 100 Hz. The permittivity of air is 8.85×10^{-12} F/m. [Ans. 0.531 ms, 5.1%]

18. Two plates of parallel plate capacitive transducer are 30 mm apart and the space is filled with two different dielectric materials, one material is 1 cm thick with a dielectric constant of 5 and the other material is 20 mm thick with a dielectric constant 10. If the capacitive transducer were to be made up of a single dielectric material, what is the dielectric constant of that material. [Ans. 7.5]

19. A parallel plate capacitive transducer uses air, as the dielectric medium for measurement of displacement as shown in Fig. 25.25. The plates are 300 mm² in area and are separated by a distance of 1.25 mm. Find the time constant and series resistance if the output is attenuated by 5% by a frequency of 30 Hz. The permittivity of air is 8.85×10^{-12} F/m. [Ans. 16.1 ms, 7580 Ω]

20. In a variable capacitance transducer the diaphragms are 20 mm in diameter and 4 mm apart. If a pressure produces an average deflection of 0.25 mm, calculate the value of capacitance after the application of force. The capacitance before application of force is 400 pF. [Ans. 427 pF]

21. A displacement capacitive transducer uses a differential arrangement with two outer plates which are fixed and a central plate which is movable. The distance between fixed and movable plates is 5 mm when no displacement is applied. A voltage of 100 V rms is applied across the fixed plates. Find the differential output voltage if a displacement of 0.01 mm is applied to the central plate. Find also the sensitivity of the transducer. [Ans. 2 V; 200 V/mm]

22. For vibration measurement a d.c. voltage of 90 V is applied across the series combination of a parallel plate air capacitor and a C.R.O. The parallel plate air capacitor has plates of 625 mm² area displaced by 0.25 mm.

The oscilloscope may be considered as a resistance of $10\text{ M}\Omega$ in parallel with a capacitance of 10 pF . The sensitivity of the oscilloscope is 1 mV/cm . Determine the displacement sensitivity and the frequency for which a flat response within 5% can be obtained. [Ans. $3.6 \times 10^8\text{ cm/cm}$; 22 kHz]

23. Air exhibits a breakdown strength of about 3 kV/mm . What limitation does this impose on the ultimate sensitivity of a variable displacement capacitive transducer.

24. The voltage sensitivity for barium titanate is $12 \times 10^{-8}\text{ Vm/N}$ while that of quartz is $50 \times 10^{-8}\text{ Vm/N}$. The permittivity of barium titanate is $12.5 \times 10^{-9}\text{ F/m}$ and that of quartz is $40.6 \times 10^{-12}\text{ F/m}$. Calculate the charge sensitivities and their ratio. If the thickness of crystal in each case is 2.5 mm , calculate the sensitivities in each case and their ratio. [Ans. 150 pC/N , 2 pC/N , $.75$; $30 \times 10^{-6}\text{ V/N-m}^{-2}$, $125 \times 10^{-6}\text{ V/N-m}^{-2}$, 0.24]

25. A quartz crystal has the dimensions of $2\text{ mm} \times 2\text{ mm} \times 1\text{ mm}$. Quartz has the following properties charge sensitivity = 2 pC/N , Young's modulus = $8.6 \times 10^{10}\text{ N/m}^2$, permittivity = $40.6 \times 10^{-12}\text{ F/m}$.

Calculate the value of force, charge and voltage if the crystal is subjected to a strain of $10 \times 10^{-6}\text{ m/m}$

[Ans. 34 N , 688 pC , 43 V]

26. A barium titanate crystal has dimensions of $5\text{ mm} \times 5\text{ mm} \times 1.5\text{ mm}$. The Young's modulus of barium titanate is $12 \times 10^8\text{ N/m}^2$, its charge sensitivity is 150 pC/N and permittivity $12.5 \times 10^{-9}\text{ F/m}$. A capacitance of 10 pF in parallel with $100\text{ M}\Omega$ resistance is connected across the crystal. Calculate the rms value of voltage under open circuit and load conditions when a force of $0.0142\text{ sin } 100\text{ t}$ newton is applied to the crystal. Calculate the rms value of deflection. The resistance of the crystal may be neglected. [Ans. 72 mV , 62.4 mV , 0.05 mm]

27. A flat frequency response within 10% is required from a piezo-electric crystal. Find the value of minimum frequency for which it can be used if the time constant is 2 ms . Find also the phase shift. [Ans. 164 Hz , 26°]

28. A piezo electric transducer has an input

$$x_i = At \quad 0 < t < T, \quad x_i = 0 \quad T < t < \infty.$$

Solve the differential equation to find the value of output voltage. For $t = T$ find the error. Calculate this error by using the following approximation.

$$e^{-T/\tau} = 1 - \frac{T}{\tau} + \frac{1}{2} \left(\frac{T}{\tau} \right)^2 - \dots$$

Explain the error as a percentage of the ideal value of output voltage. What must be the value of T/τ if the error is to be 5 percent? For this value of T/τ evaluate the error caused by truncating the series.

Signal Conditioning

26.1. Signal Conditioning

The measurand, which is basically a physical quantity as is detected by the first stage of the instrumentation or measurement system. The first stage, with which we have become familiar, is the "Detector Transduces stage". The quantity is detected and is transduced into an electrical form in most of the cases. The output of the first stage has to be modified before it becomes usable and satisfactory to drive the signal presentation stage which is the third and the last stage of a measurement system. The last stage of the measurement system may consist of indicating, recording, displaying, data processing elements or may consist of control elements.

In this chapter, methods used for modifying the transduced signal into a usable format for the final stage of the measurement system are described.

Measurement of dynamic physical quantities requires faithful representation of their analogue or digital output obtained from the intermediate stage (signal conditioning stage) and this places a severe strain on the signal conditioning equipment. The signal conditioning equipment may be required to do linear processes like amplification, attenuation, integration, differentiation, addition and subtraction. They are also required to do non-linear processes like modulation, demodulation, sampling, filtering, clipping and clamping, squaring, linearizing or multiplication by another function etc. These tasks are by no means simple. They require ingenuity, proper selection of components and the selection of most faithful methods of reproduction of output signals for the final data presentation stage.

The signal conditioning or data acquisition equipment in many a situation be an excitation and amplification system for Passive transducers. It may be an Amplification System for active transducers. In both the applications, the transducer output is brought up to a sufficient level to make it useful for conversion, processing, indicating and recording. Excitation is needed for passive transducers because these transducers do not generate their own voltage or current. Therefore, passive transducers like strain gauges, potentiometers, resistance thermometers, inductive and capacitive transducers require excitation from external sources. The active transducers like technogenerators, thermocouples, inductive pick-ups and piezo-electric crystals, on the other hand do not require an external source of excitation since they produce their own voltages on account of application of physical quantities. But these signals usually have a low voltage level, and hence, need amplification.

The excitation sources may be an alternating or a d.c. voltage source. The d.c. system is comparatively simple as shown in Fig. 26.1.

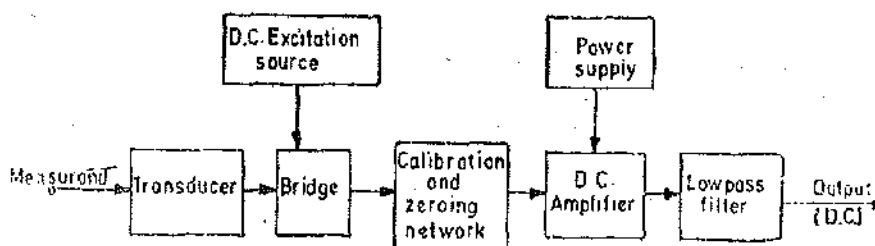

Fig. 26.1. D.C. Signal conditioning system.

The resistance transducers like strain gauges, constitute one arm or more than one arm of a Wheatstone bridge which is excited by an isolated d.c. source. The bridge can be balanced by a potentiometer and can also be calibrated for unbalanced conditions.

The desirable characteristics of a d.c. amplifier are :

- (i) It may need balanced differential inputs giving a high Common mode rejection ratio (CMRR). This is elaborated later on in this chapter.
- (ii) It should have an extremely good thermal and long term stability.

The advantages of a d.c. amplifier are that :

- (i) It is easy to calibrate at low frequencies.
- (ii) It is able to recover from an overload condition unlike its a.c. counterpart.

But the greatest disadvantage of a d.c. amplifier is that it suffers from the problem of drift. Thus low frequency spurious signals come out as data information. For this reason special low drift d.c. amplifiers are used. The d.c. amplifier is followed by a lowpass filter which is used to eliminate high frequency components or noise from the data signal.

In order to overcome the problems that are encountered in d.c. systems a.c. systems are used. In a.c. systems, the Carrier-Type a.c. Signal Conditioning systems are used as shown in Fig. 26'2.

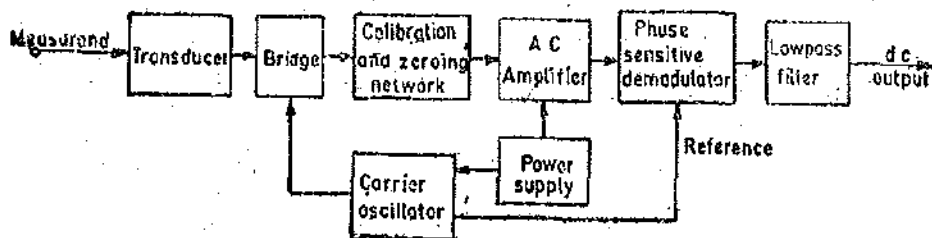

Fig. 26'2. A.C. Signal conditioning system.

The transducers used are the variable resistance or variable inductance transducers. They are employed between carrier frequencies of 50 Hz to 200 kHz. The carrier frequencies are much higher, they are atleast 5 to 10 times the signal frequencies.

Transducer parameter variations amplitude modulate the carrier frequencies at the bridge output and waveform is amplified and demodulated. The demodulation is Phase Sensitive so that the polarity of d.c. output indicates the direction of the parameter change in the bridge output.

In a carrier system amplifier drift and spurious signals are not of much importance unless they modulate the carrier. However, it is more difficult to achieve a stable carrier oscillator than a comparable d.c. stabilized source. In carrier systems, it is easy to obtain very high rejection of mains frequency pick up. Active filters can be used to reject this frequency and prevent overloading of a.c. amplifier. The phase-sensitive, demodulator filters out carrier frequency components of the data signal.

D.C. systems are generally used for common resistance transducers such as potentiometers and resistance strain gauges. A.C. systems have to be used for variable reactance transducers and for systems where signals have to be transmitted via long cables to connect the transducers to the signal conditioning equipment.

After the physical quantities like temperature, pressure, strain, acceleration etc. have been transduced into their analogous electrical form and amplified to sufficient current and voltage levels (say 1 V to 10 V), they are further processed by electronic circuits. In some applications the signal does not need any further processing and the amplified signal may be directly applied to indicating or recording or control instruments. But many applications involve further processing of signals which involve linear and non-linear operations as mentioned earlier.

The signal may be applied to a sample and hold (S/H) circuit as shown in Fig. 26'3. This may be fed to an analogue multiplexer and analogue to digital (A/D) converter. If the signal is in digital

form it may be applied to a variety of digital systems like a digital computer, digital controller, digital data logger or a digital data transmitter.

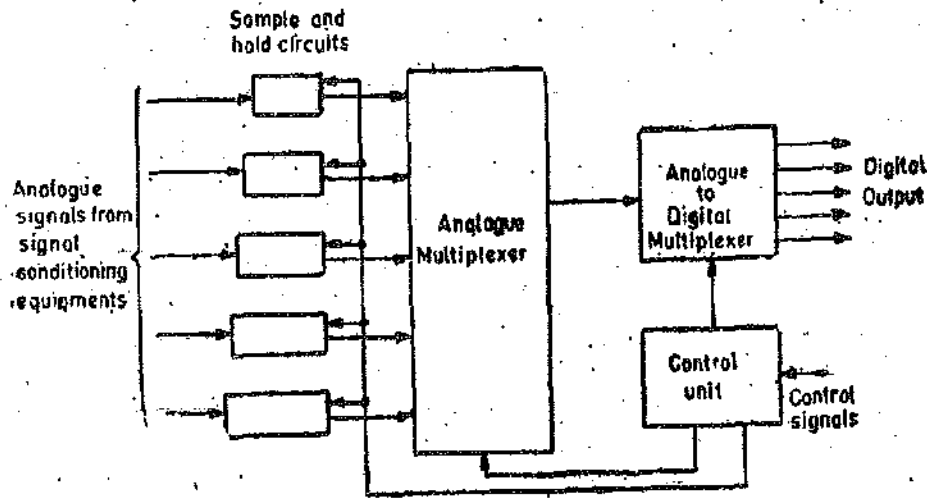

Fig. 26'3. Data acquisition and conversion system.

The sample and hold units shown in Fig. 26'3 sample the different inputs at a specified time and then hold the voltage levels at their output while analogue multiplexer performs the time division multiplexing (TDM) operation between different data inputs. Time Division Multiplexing means that each input channel is sequentially connected to the multiplexer for a certain specified time (The input signals are not applied to the multiplexer continuously but are connected in turn to the multiplexer thereby sharing time). The timing of the various input channels is controlled by a control unit. This unit controls the sample and hold (S/H) circuits, the multiplexer and the analogue to digital (A/D) converter. The control unit may be controller itself.

In case time division multiplexing is not used, the frequency division multiplexer (FDM) may be used. In this case, the multiple data analogue inputs can remain in analogue form and are transmitted all at the same time, using frequency division multiplexing (FDM). The voltage input from the signal conditioning equipment is converted into frequency. Thus any change in voltage input of the measurand produces a corresponding change in frequency.

Earlier circuits comprising of discrete electronic components were used where impedance transformations, amplification, and other signal conditioning were required. The requirement to produce designs from discrete components has given way to easier and more reliable methods of signal conditioning which use integrated circuits (ICs). Many special circuits and general purpose amplifiers are now contained in IC packages producing a quick solution to signal conditioning problems, together with small size, low power consumption and, low cost.

26'2. Instrumentation Amplifiers

The output measuring devices require power for their operation. This power is usually drawn from the measuring circuit itself. The electro-mechanical output devices require power which typically ranges from a few μW in the case of sensitive moving coil instruments to a few watt in the case of recorders.

In many applications, the measuring circuits cannot supply the power demanded by the output devices. Thus, if an output device is directly connected to the circuit, the signal gets distorted on account of the loading effects. The instrumentation amplifiers, in such cases, are required to supply the necessary power required by the output devices in order that the signal is faithfully measured, displayed or recorded.

Amplifiers are also used when the quantity under measurement has to be processed or is to be stored. The use of operational amplifiers is made for carrying out mathematical operations on the electrical signals by electrical means. These operations may include addition, subtraction, multiplica-

tion, division, integration, differentiation and taking logarithms etc. The use of amplifiers also facilitates the extraction of the measured variable in regulating and controlling circuits, while an industrial process is on. This is an on line application of the amplifiers.

An instrumentation amplifier should have the following properties :

- (i) it should be able to supply power at a specified power level a voltage or a current which is directly proportional to the quantity under measurement,
- (ii) the power extracted from the measurement system should be as small as possible,
- (iii) it should faithfully follow the variations in the quantity under measurement,
- (iv) it should operate on the least possible auxiliary power,
- (v) it should have a long operating life and a high degree of reliability,
- and (vi) the amplifier should have a high input impedance and low output impedance. High input impedance is needed so that the transducer stage is not loaded while a low output impedance is required for isolation and reduction of inter-stage interaction. The low output impedance also makes the response independent of the frequency. This property becomes very useful when high impedance transducers like piezo-electric transducers are to be coupled to low impedance signal conditioning or data presentation elements.

26.3. A.C. Amplifiers

An a.c. amplifier is designed to amplify sinusoidal signals whose frequencies lie within a particular specified range. They are designed to reproduce the input signal at the output terminals, but with voltage and/or current increased in a known ratio. An amplifier can amplify within a particular range of frequencies. The frequency range over which a flat response is obtained depends upon the value of load resistance, R_L . Ideally, the graph of voltage gain versus frequency is the response shown in Fig. 26.4 (a). The gain is constant between frequencies ω_{c1} and ω_{c2} . The gain is called the midband gain A_{mid} . In effect the a.c. amplifier acts as a bandpass filter, the passband being $\omega_{c2} - \omega_{c1}$ allowing only a band of frequencies to pass and rejecting the rest i.e. the output corresponding to rest of the frequencies is zero. The rejection bands are frequency range $0 - \omega_{c1}$ and ω_{c2} onwards.

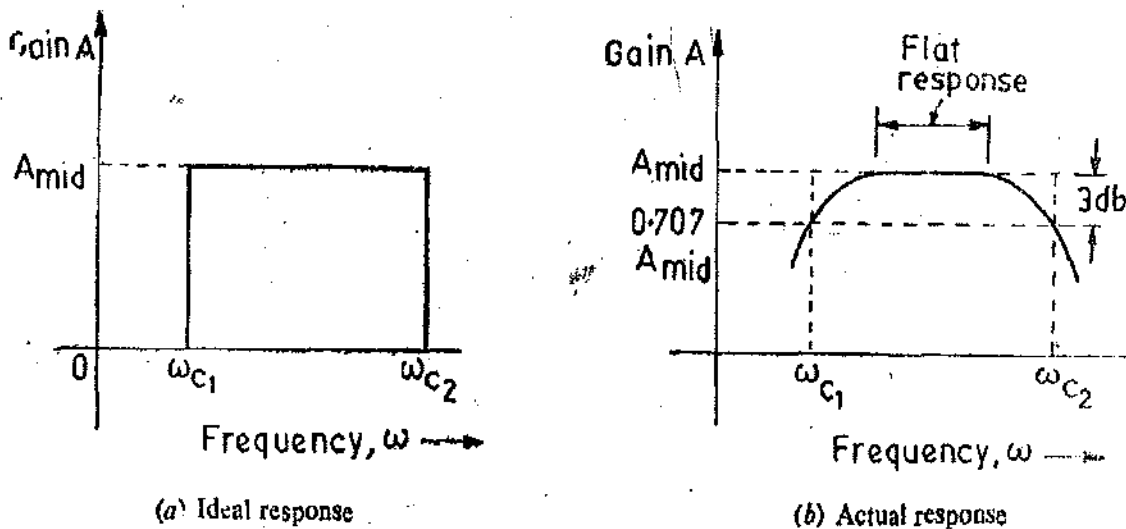

Fig. 26.4. Frequency response of a.c. amplifiers.

The ideal response, however, cannot be obtained in practice. The actual response is shown in Fig. 26.4 (b). There is a passband where we obtain an absolutely flat response. However, the gain falls below A_{mid} at some lower and upper frequencies. The frequency at which the gain is $0.707 A_{mid}$ is called Cutoff Frequency. There are two frequencies at which the gain is 0.707 of the gain at midband frequencies. These frequencies are ω_{c1} and ω_{c2} . Frequency ω_{c1} is called the lower cutoff frequency and ω_{c2} is called the upper cutoff frequency.

Bandwidth $BW = \omega_{c2} - \omega_{c1}$.

The response decreases from the midband response by 3 db. The change in power by 50% is represented by 70.7% change in voltage or by 3 db. Slow changes in the input voltage have no effect on the output voltage. The limit of the bandwidth of the amplifier for lower frequencies gives rise to a stable zero. The slow changes in the output voltage, for example drift which is normally encountered in d.c. amplifiers is avoided by this.

Thus for both the applications *i.e.* amplification of direct current signals or slow varying signals, a d.c. amplifier has to be used. The frequency response of a typical d.c. amplifier is shown in Fig. 26.5

The flat response extends all the way down to direct current or zero frequency. It should be noted that the response is basically that of a low pass filter *i.e.* it is an amplifier that reproduces the low frequency signals faithfully.

As mentioned earlier, d.c. amplifiers are mainly used in measurement and instrumentation systems. They are an essential component of an analogue computer system. However, reliable amplifiers that will amplify the d.c. inputs are difficult to design. This is because the d.c. amplifiers suffer from a major drawback and that is the problem of drift. The drift is a slow change of the output signal when the input signal is static, or perhaps nearly so *i.e.* signals varying at a very slow rate.

Another problem in d.c. amplifiers is to the need prevent any low frequency cutoff which may render them useless.

26.3.1. Direct Coupled Amplifiers. In order to eliminate the causes of low frequency cutoff and also to obtain a perfectly flat response at low frequencies direct coupled amplifiers are used. Basically, the cutoff frequencies of an a.c. amplifier are on account of coupling capacitors between various stages and the lumped capacitances. By eliminating the coupling capacitors between two stages of a multistage amplifier, the frequency cutoff can be eliminated.

Since the various successive stages of the amplifier are directly coupled without the use of a coupling capacitor, it is called a direct coupled amplifier. The direct coupled amplifiers suffer from the drift problem. Any change in supply voltage or parameters of the solid state devices used will produce an spurious output signal which is indistinguishable from the output on account of a genuine input signal. Hence, direct coupled amplifiers are suitable as d.c. amplifiers only under those conditions where the true input d.c. voltages are much larger than the voltage causing the drift.

26.3.2. Chopped and Modulated D.C. Amplifiers. Simple a.c. amplifiers may be used to amplify a d.c. input through use of an additional circuit component known as chopper. The approach is used to build a d.c. amplifier wherein the d.c. is first converted to an equivalent a.c. signal that is amplified by a standard a.c. amplifier. The a.c. signal is finally converted back to a d.c. signal.

Fig. 26.6 shows a chopper type d.c. amplifier. v_i is the input d.c. voltage. This voltage is

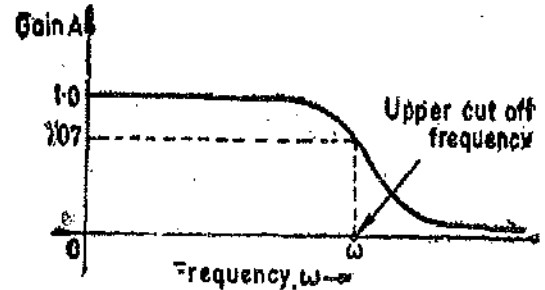

Fig. 26.5. Frequency response of a typical d.c. amplifier.

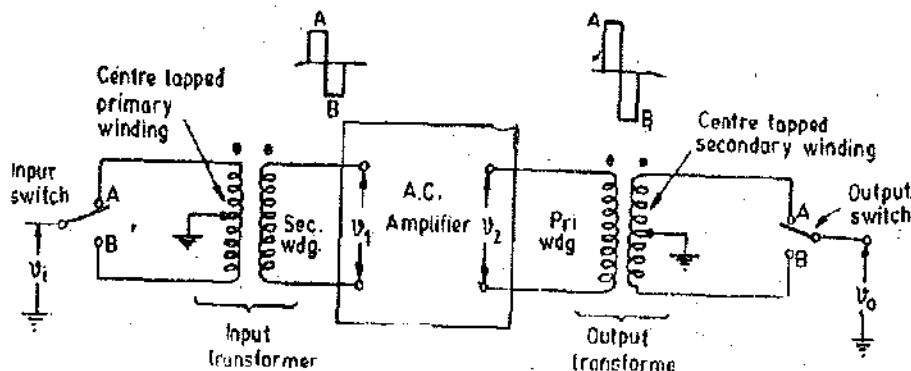

Fig. 26.6. Chopper type d.c. amplifier.

alternately connected to terminals *A* and *B*. When the switch is in position *A*, the direction of flow of current in the primary winding is in one direction. When the switch is in position *B*, the current flows in the opposite direction. This means that an a.c. voltage will be induced in the secondary winding of input transformer. For an ideal transformer this voltage is of perfect square waveshape. The peak value of the induced voltage is proportional to the d.c. input. The a.c. signal is amplified in a standard a.c. amplifier. This appears as an amplified square wave at the primary winding of the output transformer. The a.c. signal is converted back to d.c. The secondary winding of the output transformer is centrally tapped, with an output switch ganged (mechanically coupled) to the

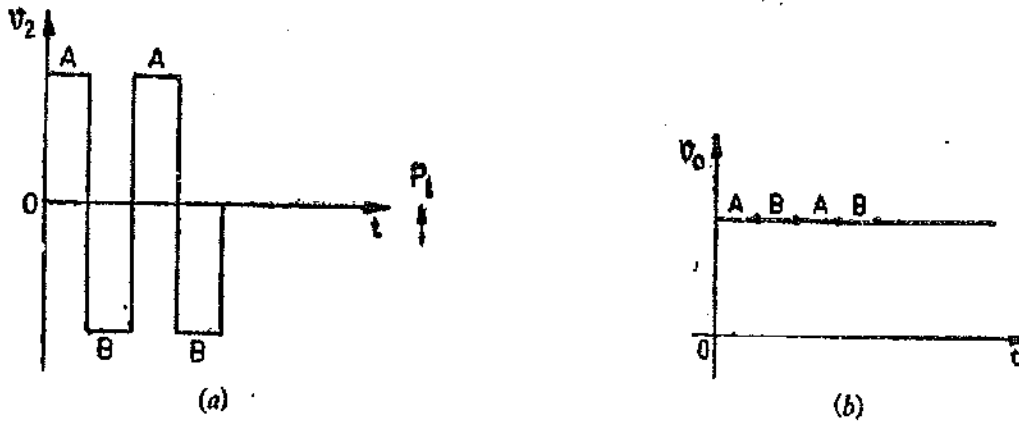

Fig. 26.7. Output of chopper amplifier.

input switch. The input voltage across the primary winding of the output transformer is shown in Fig. 26.7 (a). The output of the secondary winding is shown in Fig. 26.7 (b).

The amplifier of Fig. 26.6 is referred to as a chopper amplifier since the input d.c. voltage is literally chopped to produce an a.c. signal. The chopping action may be accomplished by either by mechanical or electronic means. A vibrating reed is used when mechanical methods are employed.

26.4. Operational Amplifiers. One type of amplifier which finds its way into almost all kinds of measurement and instrumentation systems is the Operational Amplifiers (OP AMP, for short). The word *operational* indicates that the amplifier can perform mathematical operations like inversion, addition, subtraction, multiplication, division, integration and differentiation etc.

The properties of an ideal operational amplifier are :

- (i) it should have an infinite input impedance, (ii) it should have zero output impedance,
- (iii) it should have an infinite gain, (actually it has a gain of the order of 10^5 to 10^9),
- and (iv) it should have flat response over a wide frequency range.

The operational amplifier consists of a very high gain amplifier with a negative feedback. The gain of the operational amplifier with negative feedback is determined by the feedback components and not by the internal amplifier circuitry.

Fig. 26.8 (a) shows the symbol for an operational amplifier, which is simply a triangular

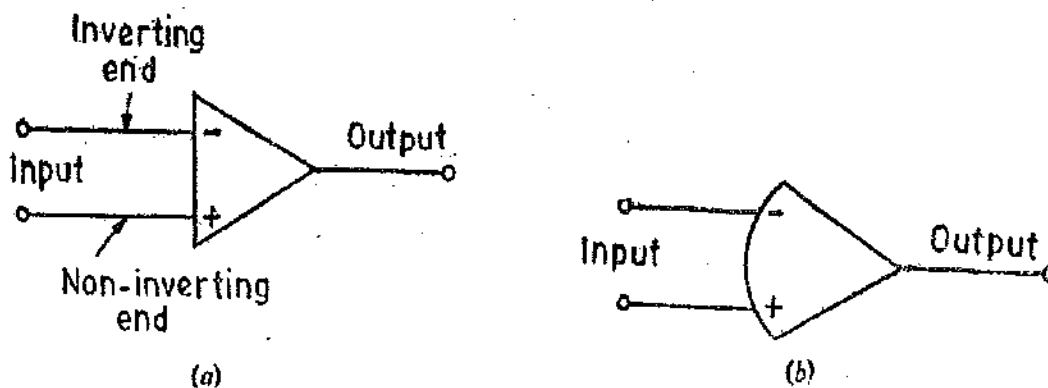

Fig. 26.8. Symbols for operational amplifiers.

shape having two inputs (normally) and a single output. The two inputs are labeled differently. One input is designated by a plus (+) sign and is called the non-inverting end. The second input is designated by a negative (-) sign and is known as inverting end.

A positive voltage applied to the non-inverting end appears as a positive voltage at the output terminals.

A positive voltage applied to the inverting end results in a negative voltage at the output terminals.

Frequently the non-inverting end is not used and some operational amplifiers do not have this terminal for use. When the non-inverting input is not available for use when the non-inverting is not provided, it is omitted from the schematic diagram and the only terminal shown is the inverting input (-ve), even though it may not be marked as such. Only one terminal is shown which is the inverting (input) terminal. The inverting input causes a reversal of polarity of the input signal. When only one input is shown, it is the inverting input. There is only one output terminal. The other terminal is the ground terminal which may not be shown in the schematic diagram. The symbol illustrated in Fig. 26'8 (a) is for an operational amplifier by itself (open loop). Frequently, the symbol depicted in Fig. 26'8 (b) is also used.

Fig. 26'9 shows the symbol and feedback connections of an operational amplifier.

Let E_i = input voltage Z_i = impedance in the input path,
 Z_1 = input impedance of amplifier, and Z_f = impedance of feedback path.

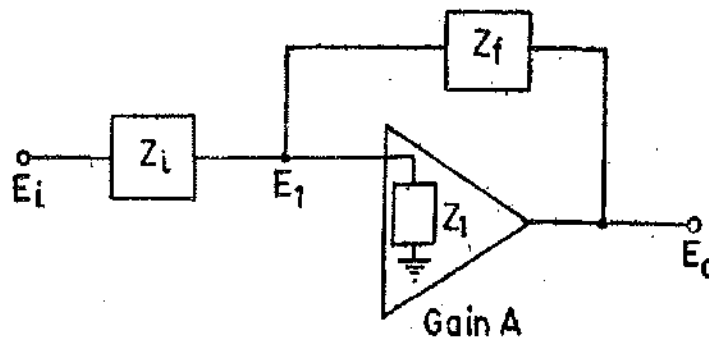

Fig. 26'9. Operational amplifier.

Since the gain of the amplifier is very large, the voltage E_1 has to be extremely small so as not to drive the amplifier to saturation. The voltage E_1 given by the two currents flowing into the node multiplied by impedance Z_1 .

$$\therefore E_1 = \left(\frac{E_i}{Z_i} + \frac{E_0}{Z_f} \right) Z_1$$

$$\text{Hence, output voltage } E_0 = AE_1 = A \left(\frac{E_i}{Z_i} + \frac{E_0}{Z_f} \right) Z_1$$

$$\text{Solving for } E_0, \quad E_0 = \left(1 - \frac{AZ_1}{Z_f} \right) = AZ_1 \frac{E_i}{Z_i} \quad \text{or} \quad E_0 \left(\frac{1}{A} - \frac{Z_1}{Z_f} \right) = Z_1 \frac{E_i}{Z_i}$$

$$\text{Now } A \gg 1 \quad \therefore -E_0 \frac{Z_1}{Z_f} = E_i \frac{Z_1}{Z_i} \quad \text{or} \quad \frac{E_0}{E_i} = - \frac{Z_f}{Z_i} \quad \dots(26'1)$$

The ratio E_0/E_i is called the closed loop gain A_{cl} .

$$\therefore \text{Closed loop gain } A_{cl} = - \frac{Z_f}{Z_i} \quad \dots(26'2)$$

Note the minus sign in Eqn. 26'2 which indicates a phase reversal. Most operational amplifiers available commercially have a differential input as shown in Fig. 26'10 (a) when operated as single ended amplifier, they have the connections shown in Fig. 26'10.

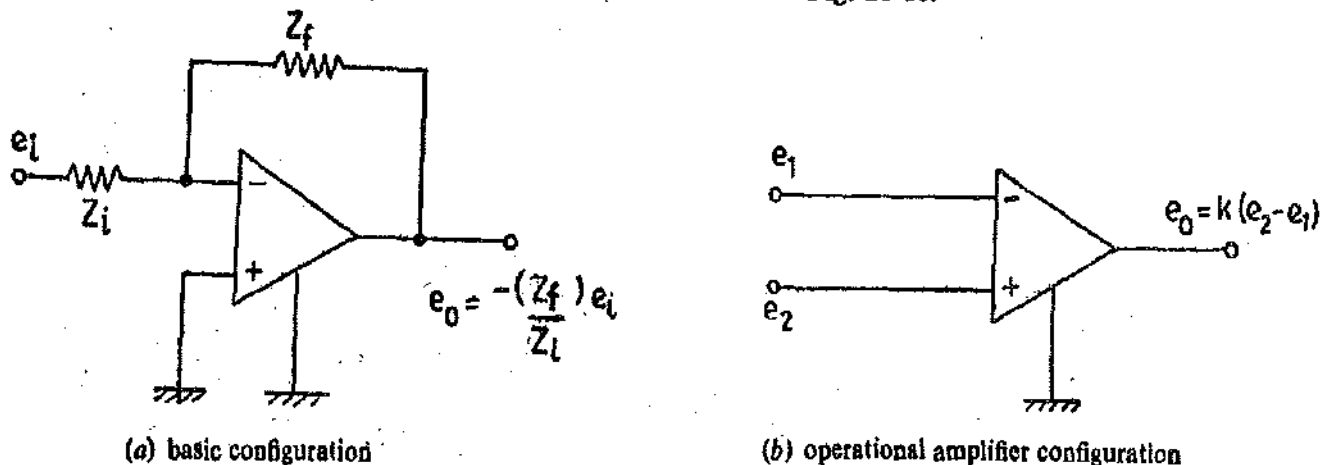

Fig. 26'10. Differential input operational amplifier.

26'5. Operational Amplifier Specifications

There are certain characteristics of operational amplifiers which must be considered for design applications. In addition to open loop design input and output impedances, following are some of the important characteristics of operational amplifiers.

1. **Input Offset Voltage.** In many cases the output voltage of the operational amplifier may not be equal to zero even though no input voltage is applied. The **Input Offset Voltage** is defined as the voltage that must be applied to the input terminals to drive the output to zero. This is about 2 mV for 741 amplifier. It should be understood that offset voltage changes with temperature.

2. **Input Offset Current.** Just as a voltage offset may be required across the input to make the output voltage zero, so a net current may be required between the inputs to zero the output voltage. This current is called **Input Offset Current**. This is equal to the difference between the two input currents. For a 741 amplifier the offset current is about 20 nA.

3. **Input Bias Current.** It is defined as the mean of the two input currents required to make the output voltage zero.

4. **Slew Rate.** It is the highest rate at which the output can change. It is expressed in terms of V/ μ s.

5. **Unity Gain Frequency.** In many cases specifications include the frequency response including unity gain frequency. This is the frequency at which the open loop gain of the amplifier becomes unity (0 db). The low frequency gain is about 20,000 and falls to unity at about 1 MHz. The amplifier is said to have a 1 MHz gain-bandwidth product.

6. **Common Mode Rejection Ratio (CMRR).** This quantity has been defined later in this chapter.

26'6. **Operational Amplifier Circuits in Instrumentation.** Some of commonly used operational amplifier circuits are described below.

26'6'1. **Inverter:** The operational amplifier is used as an inverter as shown in Fig. 26'11. The input resistance R_i is equal to the feedback resistance R_f .

$$\therefore \text{From Eqn. 26'2, the output voltage } e_o = -e_i \frac{R_f}{R_i} = -e_i \quad \dots(26'3)$$

It is clear that the output voltage is 180° out of phase with input voltage.

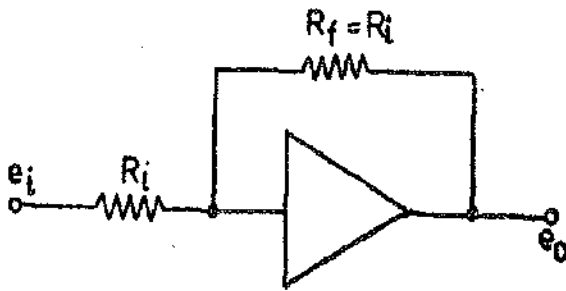

Fig. 26'11. Operational Amplifier as an inverter.

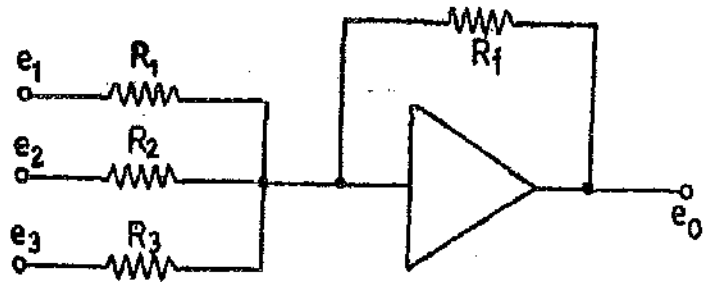

Fig. 26'12. Operational amplifier as an adder.

26'6'2. Adder : The operational amplifier acts as an adder as shown in Fig. 26'12.

$$\text{The output voltage } e_0 = -\left(e_1 \frac{R_f}{R_1} + e_2 \frac{R_f}{R_2} + e_3 \frac{R_f}{R_3}\right)$$

$$\text{If } R_1 = R_2 = R_3 = R_f \text{ we have } e_0 = -(e_1 + e_2 + e_3) \quad \dots(26'4)$$

26'6'3. Subtractor. The operational amplifier circuit subtraction of two voltages is shown in Fig. 26'13.

Output voltage of the second operational amplifier

$$e_0 = -\left(-e_1 \frac{R_f}{R_1} + e_2 \frac{R_f}{R_2}\right)$$

$$\text{If } R_1 = R_2 = R_3 = R_f \text{ we have } e_0 = e_1 - e_2. \quad \dots(26'5)$$

26'6'4. Multiplier and Divider. The output of the operational amplifier with a resistance R_f in the feedback circuit and R_i at the input is

$$e_0 = \frac{-R_f}{R_i} e_i$$

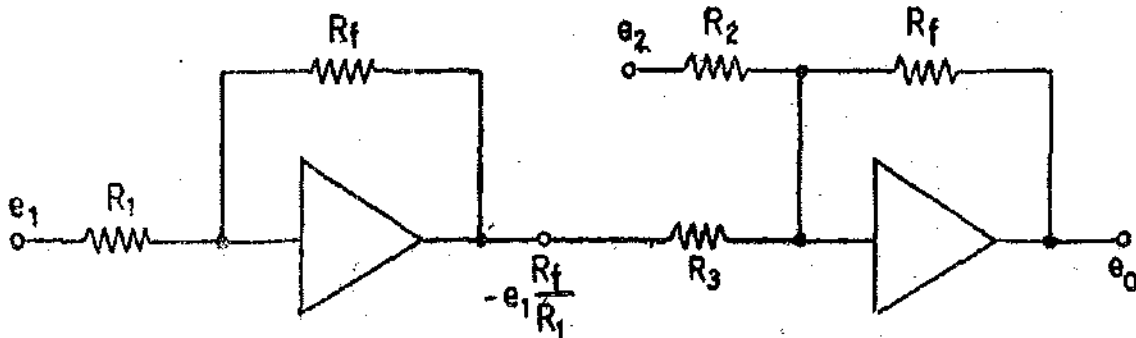

Fig. 26'13 Operational amplifier as a subtractor.

Thus the operational amplifier has $R_f > R_i$, it acts as a multiplier while if $R_f < R_i$, it acts as a divider.

Suppose $R_f = 100 \text{ M}\Omega$ and $R_i = 10 \text{ M}\Omega$.

$$e_0 = -\frac{R_f}{R_i} e_i = -\frac{100 \times 10^6}{10 \times 10^6} e_i = -10 e_i. \text{ Hence the input gets multiplied by 10.}$$

In case $R_f = 10 \text{ M}\Omega$ and $R_i = 100 \text{ M}\Omega$, the output voltage is :

$$e_0 = -\frac{10 \times 10^6}{100 \times 10^6} e_i = -\frac{1}{10} e_i.$$

Therefore the input voltage gets divided by 10. By properly choosing the input and the feedback resistances, multiplication or division by any number can be had,

26'6'5. Integrator. Fig. 26'14 shows the operational amplifier as an integrator. There is capacitor, C , in the feedback loop and a resistance, R , at the input.

The formula for integrator (as well as for differentiator) can be derived by use of Laplace transforms.

$$\text{For the integrator shown in Fig. 26'14, } \frac{e_o}{e_i} = -\frac{Z_f}{Z_i}$$

$$\text{Now } Z_f = 1/Cs \text{ and } Z_i = R. \quad \therefore \frac{E_o(s)}{E_i(s)} = -\frac{1}{RCs}$$

$$\text{or } E_o(s) = -\frac{1}{RC} \cdot \frac{1}{s} E_i(s)$$

Taking inverse Laplace transform, we have, $e_o(t) = L^{-1}[E_o(s)]$ and $e_i(t) = L^{-1}[E_i(s)]$

$$\text{Now } \int f(t) dt = \frac{1}{s} F(s) \quad \therefore e_o(t) = -\frac{1}{RC} \int e_i(t) dt \quad \dots(26'6)$$

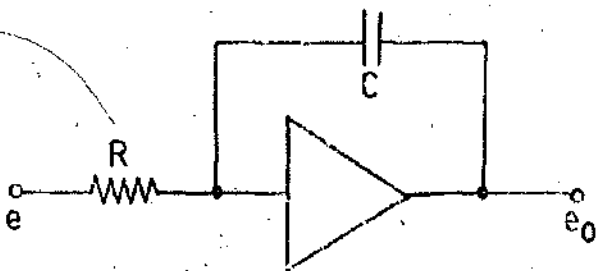

Fig. 26'14. Operational amplifier as an integrator

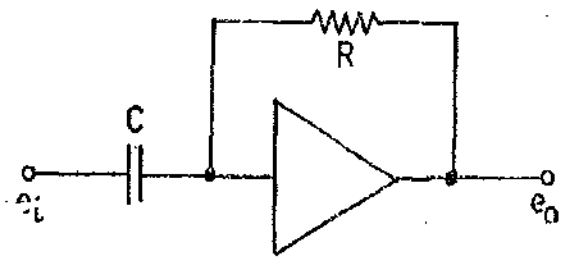

Fig. 26'15. Operational amplifier as a differentiator.

26'6'6. Differentiator. The circuit of an operational amplifier used as a differentiator is shown in Fig. 26'15.

$$\frac{e_o}{e_i} = -\frac{Z_f}{Z_i} \text{ But } Z_f = R \text{ and } Z_i = \frac{1}{Cs}$$

$$\therefore \frac{E_o(s)}{E_i(s)} = -RCs \quad \text{or } E_o(s) = -RCs E_i(s)$$

Taking inverse Laplace transform

$$\text{As } sE_i(s) = \frac{d e_i(t)}{dt} \quad \therefore e_o(t) = -RC \frac{d e_i(t)}{dt} \quad \dots(26'7)$$

The operational amplifiers are normally not used as differentiators because they try to decrease the signal to noise ratio.

Suppose we have an input signal : $e_i = 2 \sin \omega t + 0.001 \sin 300 \omega t$.

The signal to noise ratio at the input is $S/N = 2/0.001 = 2000$.

If this signal is fed to a differentiator, the output is :

$$e_o = -RC [2\omega \cos \omega t + 0.001 \times 300 \omega \cos 300 \omega t] = -RC [2\omega \cos \omega t + 0.3 \omega \cos 300 \omega t]$$

\therefore Signal to noise ratio at the output is : $S/N = 2\omega/0.3\omega = 6.66$.

Therefore the noise level increases immensely at the output. Hence the operational amplifiers are not used as differentiators.

The operational amplifiers have a wide range of applications in Measurement and Instrumentation systems. This is because of their high gain that permits the use of feedback to achieve extremely stable amplification. The operational amplifiers are usually designed for low power applica-

tions, where a constant gain down to d.c. is required. They are used in analogue computers, analogue to digital (A/D) converters and digital to analogue (D/A) converters.

26'6'7. Attenuated Feedback. In many applications use of low and medium value resistors are used for attenuation of the feedback as shown in Fig. 26'16. This has the advantage of using resistors which can be easily manufactured within reasonable limits of accuracy while retaining a high stable gain.

Let us consider an example. Suppose a closed loop gain of 1000 and an input impedance of 10 kΩ is desired. If the circuit of Fig. 26'11 (b) is used, the feedback resistor R_f must have a value of 10 MΩ. It is difficult to obtain resistors of such high value with a tolerance of less than $\pm 5\%$. The gain with circuit of Fig. 26'16 is :

$$\frac{e_o}{e_i} = \frac{R_f}{R_1} \left(\frac{R_1 + R_2}{R_2} \right) \text{ with } R_2 \ll R_f \quad \dots(26'8)$$

Now with $R_f = 10 \text{ k}\Omega$, $R_f = 100 \text{ k}\Omega$, $R_1 = 1 \text{ k}\Omega$ value of R_2 to get gain of 1000 is approximately 10 Ω. The values of resistance are more likely to be stable than the 10 MΩ resistance of first arrangement.

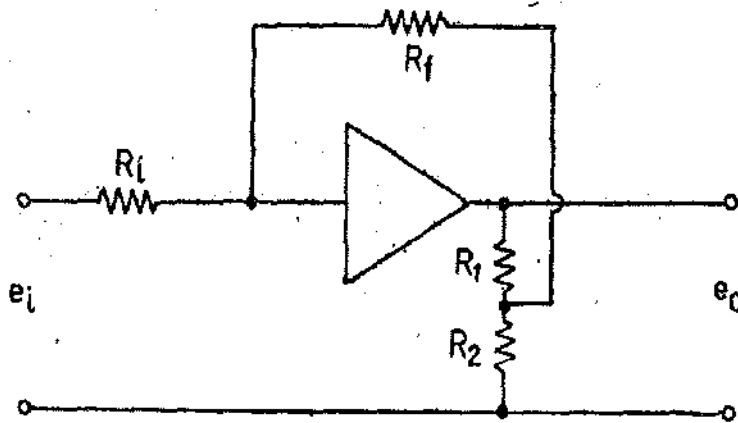

Fig. 26'16. Operational amplifier with attenuated feedback.

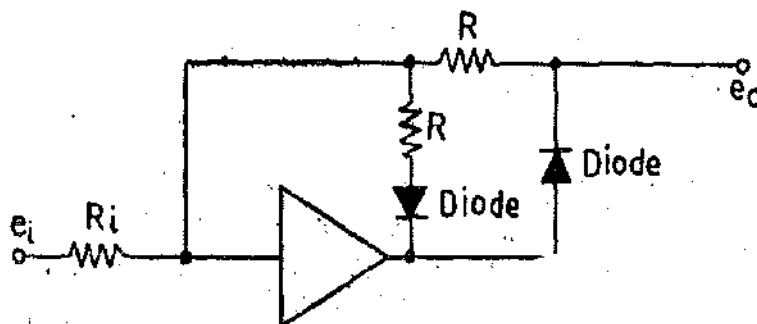

Fig. 26'17. Ideal rectifier circuit.

26'6'8. Ideal Rectifier. The difficulty encountered when using ordinary rectifier circuits is that the forward voltage drop of diodes prevents the straight forward use of these devices if the magnitude of the signals is small. However, if a circuit shown in Fig. 26'17 which incorporates an operational amplifier with diodes in the feedback, is used the problem is overcome effectively and an ideal rectifier is obtained.

26'6'9. Logarithmic Converter. Another application of the single ended amplifier is as a logarithmic converter which is shown in Fig. 26'18. A silicon diode is placed in the feedback loop.

The current of the diode depends upon the output voltage. From the summation of current, we get

$$\frac{e_i}{R_i} + f(e_o) = 0 \quad \dots(26'9)$$

where $f(e_o) =$ variation of the current with voltage and is exponential in the case of a diode,

$$f(e_o) = F_o e^{\beta e_o}$$

where $F_o =$ amplitude constant and $\beta =$ exponential constant

$$\frac{e_i}{R_i} + F_o e^{\beta e_o} = 0$$

or
$$e_o = \frac{1}{\beta} \log_e (e_i) - \frac{1}{\beta} \log_e (F_o R_i) \quad \dots(26.10)$$

Thus output obtained is a logarithmic function of the input.

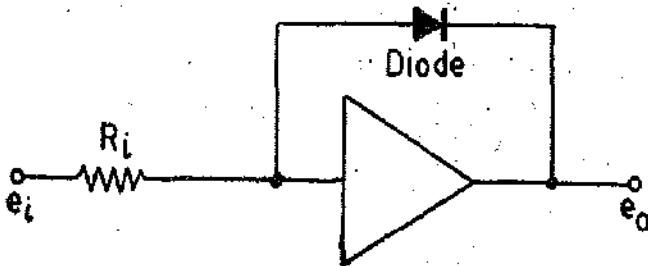

Fig. 26.18. Logarithmic Converter.

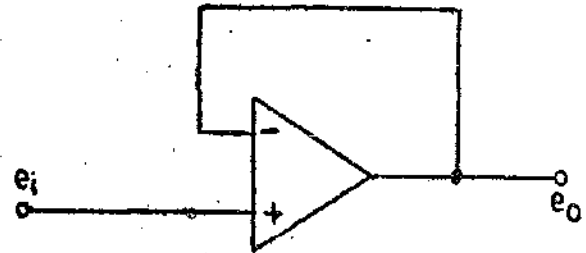

Fig. 26.19. Unity gain buffer amplifier (voltage follower).

26.10. Buffer Amplifier. The circuit of a unity gain buffer amplifier also called a voltage follower is shown in Fig. 26.19.

This circuit has a unity gain and a very high input impedance. The input impedance is essentially the input impedance of the operational amplifier itself which may be greater than 100 MΩ. The output voltage is equal to the input voltage. In fact, the output voltage tracks the input voltage from plus to negative saturation levels. Current output is limited to short circuit current of the operational amplifier and the output impedance is small, typically less than 100 Ω. Many manufacturers market operational amplifiers with internally provided feedback. These are used as buffer amplifiers and have a very high input impedance.

The buffer amplifier is essentially an impedance transformer which converts a voltage at high impedance to the same voltage at low impedance. The use of unity gain buffer amplifiers greatly reduces the loading effects in measurement systems.

26.11. Differential Amplifier. An operational amplifier which is very important in Instrumentation is the differential amplifier. In its basic form it has two inputs and two outputs. The signal available to the two outputs are identical except that one is 180° out of phase with the other. The output voltage of the amplifier is proportional to the difference between the two input voltages.

Fig. 26.20 shows a differential amplifier. It is noted that only one output terminal is shown.

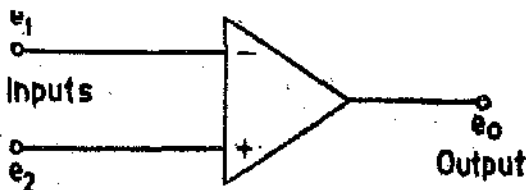

Fig. 26.20. Differential amplifier.

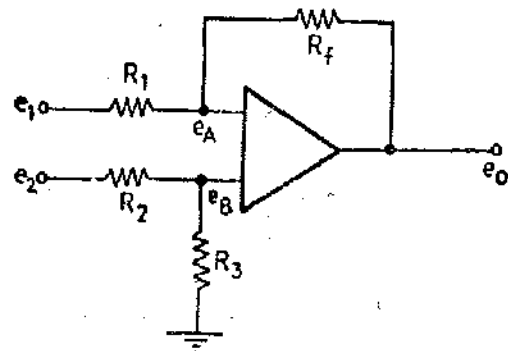

Fig. 26.21. Operational amplifier used as a differential amplifier.

This is because in most applications only one of the two outputs is used. When such amplifiers are in IC form both outputs are usually available.

The basic differential amplifier shown in Fig. 26.21 produces an output which is a difference between two inputs.

$$e_o = A_d(e_B - e_A) \quad \text{where } A_d = \text{gain factor.}$$

The operational differential amplifier is designed to have a very high differential gain. This means, $e_o/(e_B - e_A) = 10^5$ or more. Also this high gain implies that $e_B - e_A \approx 0$. Since e_o has a limited amplitude and therefore $e_o/(e_B - e_A)$ is very large. The differential voltage *i.e.* $(e_B - e_A)$ is very small. Thus we can assume that $e_A \approx e_B$.

The input impedances of a differential amplifier are quite large, and, therefore, can be neglected. For negative feedback, the path must be from output to -ve terminal of input. Now e_o is shifted by 180° with respect to e_A (-input) and 0° with respect to e_B (+input).

$$\text{Voltage between } e_1 \text{ and ground} = \frac{e_o R_1}{R_f + R_1}$$

$$\text{Voltage between } e_o \text{ and ground} = \frac{e_o R_f}{R_f + R_1}$$

$$\therefore \text{By superposition, we get, } e_A = \frac{e_o R_1}{R_f + R_1} + \frac{e_1 R_f}{R_f + R_1}$$

$$\text{Now, } e_B = \frac{e_2 R_3}{R_2 + R_3}$$

$$\text{Since } e_A \approx e_B, \text{ we have: } \frac{e_o R_1}{R_f + R_1} + \frac{e_1 R_f}{R_f + R_1} = \frac{e_2 R_3}{R_2 + R_3}$$

$$\text{or } e_o = e_2 \frac{R_3(R_f + R_1)}{R_1(R_2 + R_3)} - e_1 \frac{R_f}{R_1}$$

$$\text{Putting } \frac{R_f}{R_1} = \frac{R_3}{R_2} = A_d \text{ we get, } e_o = \frac{R_f}{R_1} (e_2 - e_1) = A_d(e_2 - e_1) \quad \dots(26.11)$$

A_d is called the **Difference Mode gain**. The signal $e_d = e_2 - e_1$, is called the **Difference Mode Signal** or simply **Difference Signal**.

$$\therefore A_d = e_o/(e_2 - e_1) = e_o/e_d \quad \dots(26.12)$$

Common Mode Signals. The output voltage of a differential amplifier is proportional to the difference between the input voltages. Thus if there is no difference between the two input voltages *i.e.* when they are equal, the output voltage is zero. Equal inputs are known as **common mode signals** because the input signal is common to both inputs. The lack of response (zero output) is the outstanding feature of the differential amplifier.

However, in actual practice when equal input voltages are applied to the two inputs, the output is not exactly equal to zero on account of difference in response of the two inputs to common mode signals. The output of a practical difference amplifier with common mode signals is typically of the order of several hundred microvolt.

We can now distinguish between the gain for the desired difference signal and the gain for the common mode signal by referring to the former as the **difference mode gain** and the latter as the **common mode gain**.

$$\text{Common mode gain} \quad A_c = e_o/e_c \quad \dots(26.13)$$

$$\text{where } e_c = \text{common mode input signal.}$$

In fact e_c is the value of the input signal that is common to both inputs, and e_o is the output signal resulting from the common mode input signal.

Common Mode Rejection Ratio (CMRR). The common mode rejection ratio (CMRR) is defined as :

$$\text{CMRR} = A_d/A_c \quad \dots(26.14)$$

The common mode rejection ratio (CMRR) is frequently expressed in db.

$$\text{CMRR} = 20 \log_{10} (A_d/A_c) \quad \dots(26.15)$$

In an ideal amplifier, this ratio should be infinity but in practice it is not and has a finite value. CMRR is a measure of ratio of the desired signal to the undesired signal. The larger the CMRR, the better is the amplifier.

Advantages of differential amplifiers. The advantages of differential amplifiers are :

1. **Noise Immunity.** The differential amplifier can be used in situations where the operation of single ended operational amplifiers is impossible on account of interference from pick-up and ground potential differences. When a difference amplifier is used, ideally it responds only to the difference signal between input terminals and ignores the pick-up and ground voltages that appear in phase on both signal lines.

The differential amplifiers is extensively used in equipment such as electronic voltmeters and oscilloscopes. Usually the first stage of such an instrument is known as **Differential Input**, or **Balanced Input** or **Push-pull Input**.

The advantage of this form of construction is that the two input terminals are located physically close to each other. Consequently noise pick-up (such as hum from power lines or electrical equipment, "static" from fluorescent lights etc.) tends to be equal on the two terminals. Also, the wires can be twisted together to equate the pick-up on both the terminals. Therefore the noise and hum pick-up will be a common mode signal and so the response of a differential amplifier to this is negligible on account of high value of CMRR.

On the other hand the desired signal can be arranged to be equal and 180° out of phase at the two input terminals, so that the difference signal $e_d = e_2 - e_1$ is additive. Thus a 50 mV signal is made +50 mV at one terminal and -50 mV at the other terminal, with the result that the difference mode input signal is $e_d = e_2 - e_1 = 100$ mV. When a signal source provides this type of output signal it is known as a "balanced output" or "push-pull" source. Fig. 26.22 shows an arrange-

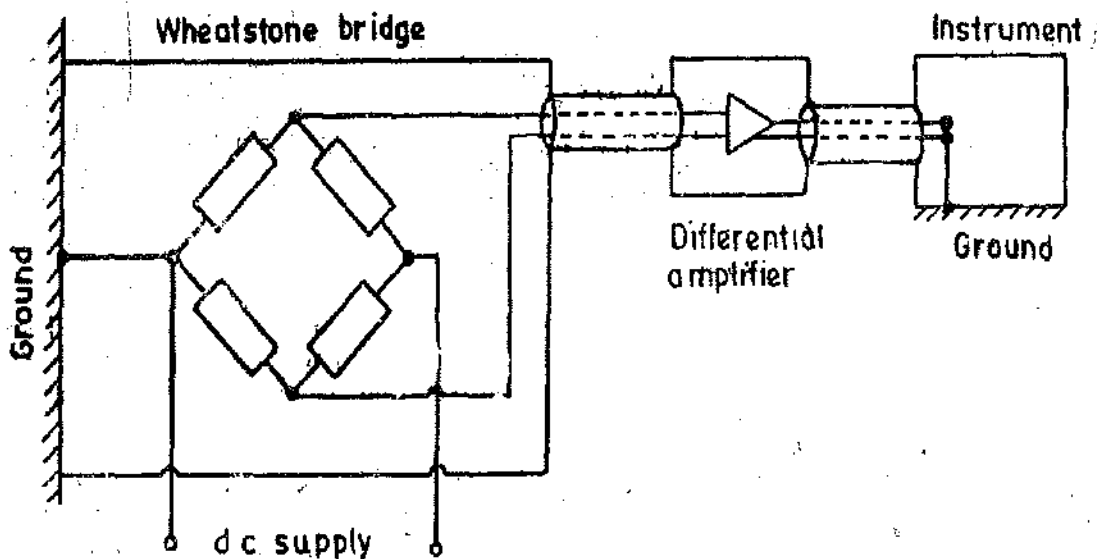

Fig. 26.22. Use of a differential amplifier, when both source and instrument have an earth point.

ment when the output voltage of a Wheatstone bridge is measured with the help of an instrument with an amplifier in-between. The signal source (Wheatstone bridge) and instrument are both earthed. Therefore, a common mode signal is applied to the amplifier and naturally it requires the use of a differential amplifier so as to eliminate spurious signals on account of earth potentials.

2. Drift Immunity. One of the major problems in amplifier design is the change in the value of gain and of voltage levels due to aging and variations in temperature. These changes take place slowly and are, therefore, called **Drift**. The problem of drift may assume very serious proportions in Electronic Instrumentation systems as even an extremely small change may affect the results drastically.

The differential amplifier has inherent capabilities of eliminating problem of drift. The two inputs and two outputs that characterize the amplifier are the result of the fact that it is made up of two identical amplifiers connected side by side. Thus any changes, due to aging or variations in temperature which occur on one side are duplicated on the other side. Therefore, these effects may be considered as two identical signals, or in other words a common mode signal. Since, a differential amplifier has a high value of CMRR, the net effect of the drift is almost negligible. In case the two sides of the amplifier are made absolutely identical the effects on account of aging and temperature changes will affect the two sides equally and hence there will be no output on account of these changes. Thus, the drift problem is completely eliminated.

On account of features described above the differential amplifier construction is used for the early stages of oscilloscope and electronic voltmeter amplifiers, where low drift is extremely important.

26.6.12. Use of Operational Amplifier with Capacitive Displacement Transducers

Suppose a capacitive transducer is used for measurement of displacement. The principle involved is change of capacitance with change of distance between plates. The capacitor has air as dielectric medium. The capacitance is given by: $C_x = \frac{\epsilon_0 A}{x}$ where A is the area of the plates and x is the distance between plates.

This represents a non-linear relationship between output *i.e.*, capacitance and input *i.e.*, displacement, x . A linear relationship between output and input can be obtained, by using an operational amplifier as shown in Fig. 26.24.

This is done by connecting the operational amplifier in the feedback loop. Therefore, we have:

$$\frac{e_0}{e_i} = -\frac{Z_f}{Z_i} = -\frac{1}{\omega C_x} \times \omega C_i = -\frac{C_i}{\epsilon_0 A/x}$$

$$\therefore \text{Output voltage } e_0 = e_i = \left(-\frac{C_i e_i}{\epsilon_0 A} \right) x = Kx \quad \dots(26.16)$$

$$\text{where sensitivity } K = \left(-\frac{C_i}{\epsilon_0 A} e_i \right) \text{ V/m.} \quad \dots(26.17)$$

Thus a linear relationship is obtained between output and input. In commercial instruments the input voltage e_i is a 50 kHz sine wave of fixed amplitude. The output e_0 is also a 50 kHz sine wave which is connected to rectifiers to obtain a d.c. output that is read by d.c. instruments. This system is used for measurement of static displacements. For dynamic displacements, the signal e_0 is a modulated wave and will have to be fed to demodulators and low pass filters.

26.6.13. Charge Amplifiers

Piezo-electric transducers are extensively used in accelerometers, pressure pick-ups, and load cells. The output of a piezo-electric transducer is charge. The charge is converted to voltage. This

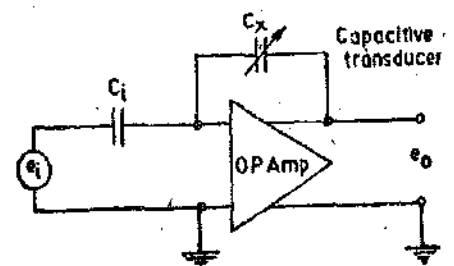

Fig. 26.24. Operational amplifier used in conjunction with capacitive transducers.

has led to development of a special kind of an amplifier, called a charge amplifier. The charge amplifier offers some advantages over the usual voltage amplifiers in certain applications.

A charge amplifier can be described by considering it as an operational amplifier with capacitive feedback. A block diagram of the charge amplifier is shown in Fig. 26'25.

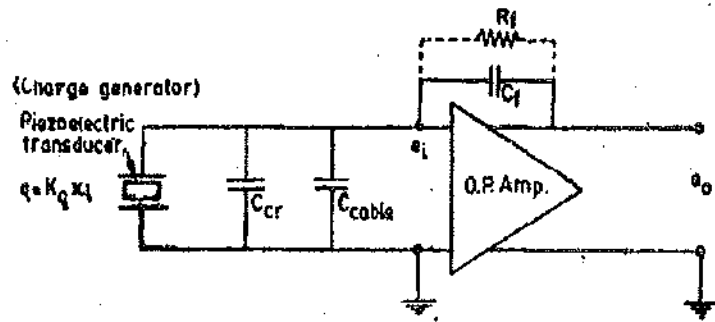

Fig. 26'25. Charge Amplifier.

$$\text{Now, } \frac{e_0}{e_1} = - \frac{C_{cr} + C_{cable}}{C_f} \quad \dots(26'18)$$

where C_{cr} = capacitance of crystal ; F, C_{cable} = capacitance of cable ; F.

$$\text{Let } C = C_{cr} + C_{cable}. \quad \therefore \frac{e_0}{e_1} = - \frac{C}{C_f} \quad \dots(26'19)$$

But $e_1 = q/C$ where q is the charge generated.

$$\therefore e_0 = - \frac{C}{C_f} e_1 = - \frac{C}{C_f} \times \frac{q}{C} = - \frac{q}{C_f} \quad \dots(26'20)$$

Let K_q = charge sensitivity ; C/m, and x_1 = input displacement ; m.

$$\therefore e_0 = - \frac{q}{C_f} = - \frac{K_q x_1}{C_f} \quad \dots(26'21)$$

Eqn. 26 21 indicates that the output voltage e_0 is linearly related to input displacement, x_1 . It also indicates that the output changes instantaneously with input without loss in the steady state response. But unfortunately in practice, it is not so. This is because the operational amplifier does not have an infinite input resistance as is assumed, but has a finite input resistance though very high. The input resistance and the leakage resistance of C_f , exhibit a steady charging of C_f by the leakage current till the amplifier is saturated. To overcome this problem, a resistance R_f is connected across capacitor C_f in the feedback path. This prevents the small leakage current to charge the capacitor heavily. The connection of R_f is shown by a dotted line. The output-input relationship is now :

$$\frac{E_0(s)}{X_1(s)} = \frac{K \tau s}{1 + \tau s} \quad \dots(26'22)$$

where K = voltage sensitivity = $\frac{K_q}{C_f}$; V/m, and τ = time constant = $R_f C_f$; s.

$$\text{The amplitude ratio is } M = \frac{1}{K} \left| \left(\frac{e_0(j\omega)}{x_1(j\omega)} \right) \right| = \frac{1}{\sqrt{1 + 1/\omega^2 \tau^2}} \quad \dots(26'23)$$

Therefore, the frequency response of a charge amplifier is similar to that of a piezo-electric transducer. The amplifier exhibits attenuation of output at low frequencies. This response is shown in Fig. 26'26.

The advantages of a charge amplifier are :

(i) The output voltage is proportional to the charge produced by the piezo-electric transducer.

(ii) The amount of charge present is not affected by the cable capacitance. Since the amplifier detects charge rather than voltage, the system is completely independent of

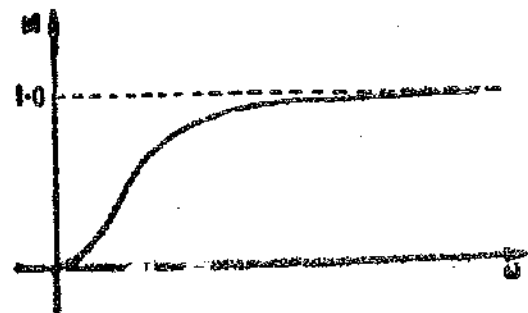

Fig. 26'26. Frequency response of a charge amplifier.

shunt capacitances and the changes in their value. This is important because of the fact that the output is not influenced by cable capacitance and hence large cable lengths can be used without any distortion of the input signal. Also the system temperature characteristics are dependent only on the charge versus temperature characteristics of the transducer and are not affected by changes in the capacitance of transducer or the cable.

(iii) The sensitivity, K , as well as the time constant are independent of the capacitance of the crystal and also that of connecting cables. These advantages are not available in ordinary voltage amplifiers.

There are certain disadvantages of charge amplifiers which may be present in certain applications. These disadvantages may be :

(i) The signal to noise ratio (S/N) tends to be small.

(ii) The natural frequency of the transducer is reduced due to loss of stiffness caused by what amounts to a short circuit across the crystal.

In practical piezo-electric transducers, the value of C_f varies from 10 to 100,000 pF. The value of R_f used is between 10^{10} and $10^{14} \Omega$. The high value of time constant results in almost a d.c. response.

In addition to above applications operational amplifiers are used in Sample Hold Circuits, voltage to current converters, current to voltage converters and digital to analog (D/A) converters.

Example 26'1. (a) An inverting amplifier has a resistance of $100 \text{ k}\Omega$ in its feedback path and a resistance of $1 \text{ k}\Omega$ at its input terminals. What is the gain? (b) An operational amplifier is to be built with its internal resistance of $10 \text{ k}\Omega$. What should be the value of feedback resistance if it acts as a multiplier with a factor of 10.

Solution : (a)
$$\text{Gain} = \frac{e_0}{e_i} = \frac{R_f}{R_i} = \frac{100 \times 10^3}{1 \times 10^3} = 100.$$

(b) Output voltage $e_0 = e_i \frac{R_f}{R_i}$ But $e_0 = 10e_i$ and $R_i = 10 \text{ k}\Omega$.

$\therefore R_f = \frac{e_0}{e_i} R_i = 10 \times 10 \times 10^3 = 100 \times 10^3 \Omega = 100 \text{ k}\Omega.$

Example 26'2. Three signals E_1 , E_2 , and E_3 are to be weighted in the ratios 1, 0.5, 0.333 multiplied by -10 , and added in the output of an operational amplifier. If the feedback resistance of the operational amplifier is $10 \text{ k}\Omega$, what are the values for input resistances R_1 , R_2 and R_3 ?

Solution. output voltage
$$E_0 = - \left(\frac{R_f}{R_1} E_1 + \frac{R_f}{R_2} E_2 + \frac{R_f}{R_3} E_3 \right)$$

Now, $R_f/R_1 = 10$ and therefore $R_1 = R_f/10 = (10 \times 10^3/10) \Omega = 1 \text{ k}\Omega$

Similarly, $R_2 = (10 \times 10^3/0.5) \Omega = 20 \text{ k}\Omega$

and $R_3 = (10 \times 10^3/0.333) \Omega = 30 \text{ k}\Omega.$

Example 26'3. An operational amplifier is used as an integrator to produce a ramp signal of 10 V/ms . Design the circuit for this.

Solution. When an operational amplifier is used as an integrator :
$$E_0 = - \frac{E_i}{RC} t$$

It will produce a ramp output when the input voltage E_i is constant. Let $E_i = -10 \text{ V}$.

$\therefore E_0 = (10/RC) t.$

Thus for production of a ramp output 10 V/ms , $RC = 1 \text{ ms}$.

With $C = 1 \mu\text{F}$ and $R = 1 \text{ k}\Omega$, we get $RC = 1000 \times 1 \times 10^{-6} \text{ s} = 1 \text{ ms}$.

Therefore, the ramp generator requires a constant voltage source of -10 V a capacitor of $1 \mu\text{F}$ in the feedback circuit and a resistance $1 \text{ k}\Omega$ at the input.

Example 26.4. (a) A differential amplifier has two inputs of 5 mV and 3 mV. The output is 300 mV. What is the amplifier gain? (b) If now inputs of 153 mV and 155 mV are applied, what is output voltage?

Solution. (a) Difference mode gain $A_d = \frac{e_0}{e_2 - e_1} = \frac{300 \times 10^{-3}}{(5-3) \times 10^{-3}} = 150.$

(b) Output voltage $e_0 = A_d (e_1 - e_2) = 150(155 - 153) = 300 \text{ mV}.$

Note that the inputs in the second case are much larger than what they are in the first case. Same output voltage is obtained since the difference of the two input voltages is the same *i.e.*, 2 mV.

Example 26.5. A differential amplifier with a common-mode input of 500 mV and a difference-mode input of 30 mV has an output of 5 mV due to the common mode input and 3 V due to difference mode input. Find the difference-mode and the common mode gains. Find also the common mode rejection ratio.

Solution.

Difference mode gain $A_d = \frac{e_0}{e_d} = \frac{3}{30 \times 10^{-3}} = 100.$

Common mode gain $A_c = \frac{e_0}{e_c} = \frac{5 \times 10^{-3}}{500 \times 10^{-3}} = 0.01.$

\therefore Common mode rejection ratio $\text{CMRR} = \frac{A_d}{A_c} = \frac{100}{0.01} = 10,000 = 80 \text{ db}.$

Example 26.6. A balanced-output source provides a signal of 30 mV from each terminal to ground. This provides a difference signal of 60 mV for a difference amplifier. The noise signal common to both terminals is 600 mV. The differential gain of the amplifier is 150, while the common mode gain is 0.04. What is the ratio of signal to noise at the output? Comment upon the result.

Solution. The balanced source provides an output of 30 mV from each terminal to ground.

Thus $e_2 = 30 \text{ mV}, e_1 = -30 \text{ mV}$

\therefore Difference mode input $e_d = 30 - (-30) = 60 \text{ mV}.$

Signal output voltage $e_{0s} = A_d e_d = 150 \times 60 \times 10^{-3} = 9 \text{ V}.$

The noise at the input terminals has a magnitude of 600 mV.

\therefore Noise output voltage $e_{0N} = A_c e_c = 0.04 \times 600 \times 10^{-3} \text{ V} = 24 \text{ mV}.$

\therefore Signal to noise ratio $S/N = \frac{e_{0s}}{e_{0N}} = \frac{9}{24 \times 10^{-3}} = 375.$

Common mode rejection ratio $\text{CMRR} = \frac{A_d}{A_c} = \frac{150}{0.04} = 3750.$

Comments. We find that the noise signal is 10 times as great as the desirable signal at the input but at the output, the noise signal is 1/375 of the desired signal. Therefore, the noise has been reduced by a factor $10 \times 375 = 3750$, which is equal to (CMRR) by the use of a difference amplifier. Therefore, difference amplifiers are very useful where elimination of common mode undesirable signals is concerned.

Example 26.7. A capacitive displacement transducer has plates of area 200 mm². The distance between plates is variable. The dielectric medium is air. This capacitor is used in the feedback loop of an operational amplifier. The capacitor is connected at the input end of the operational amplifier has a capacitance of 10 pF. Calculate the sensitivity and also calculate the voltage output if the displacement is 1 μm .

Solution. The sensitivity is given by Eqn. 26.17.

Sensitivity $K = -\left(\frac{C_t}{\epsilon_0 A} e_i\right) = -\left(\frac{100 \times 10^{-12}}{8.85 \times 10^{-12} \times 200 \times 10^{-6}} \times 10\right) = 0.057 \times 10^6 \text{ V/mm}.$

Voltage output corresponding to a displacement of 1 μm is :

$$e_0 = 0.057 \times 10^8 \times 10^{-6} = 0.057 \text{ V} = 57 \text{ mV.}$$

Example 26.8. Ceramic type capacitive transducers have capacitance in the range of 10 to 1000 pF and shunt resistance of 10^8 to $10^{10} \Omega$. Find the maximum and minimum time constants. Can these capacitors be used in the feedback loop of charge amplifiers ?

Solution. Maximum time constant = $10^{10} \times 1000 \times 10^{-12} = 10 \text{ s.}$

Minimum time constant = $10^8 \times 10 \times 10^{-12} = 10^{-3} \text{ s.}$

(i) Let us find out the lowest frequency for which it can be used for a response within $\pm 5\%$.

Amplitude ratio $0.95 = \frac{1}{\sqrt{1 + (1/2\pi f \times 10)^2}}$ or minimum allowable frequency $f = 0.048 \text{ Hz.}$

(ii) For a time constant $\tau = 10^{-3}$, the minimum frequency can similarly be found.

or $0.95 = \frac{1}{\sqrt{1 + (1/2\pi f \times 10^{-3})^2}} \therefore f = 484 \text{ Hz.}$

Therefore these capacitors cannot be used for slow varying signals.

26.7. Amplitude Modulation. The term **Modulation** means "to charge" or "to modify".

The interest in amplitude modulated signals in measurement systems is on account of two reasons :

1. Physical data that are to be measured, processed and interpreted are, many a times, amplitude modulated.
2. When carrying out dynamic measurements, the measurement systems are intentionally designed to introduce amplitude modulation on account of various advantages.

There are, invariably, two parts to any method of modulation.

- (i) **Carrier.** This is the medium that carries the information.
- and (ii) **Signal.** The signal is the information to be carried.

In amplitude modulation (AM) the signal or the information modulates the amplitude of the carrier. Qualitatively, amplitude modulation may be defined as the modification of the amplitude of the carrier in proportion to the amplitude of the modulating signals. In general, the signal that modulates the amplitude of a carrier wave may be of any form, it may be a single sine wave, a periodic function, a random wave or a transient phenomenon. Similarly the carrier may also be of different forms i.e., it may be a sine wave or a square wave etc.

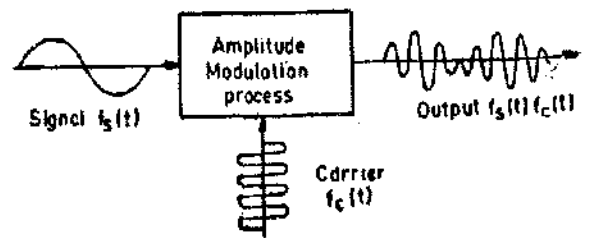

Fig. 26.27. Amplitude modulation of a sinusoidal signal.

In order to understand the concept of amplitude modulation, the simplest form is a sinusoidal signal modulating the amplitude of a sinusoidal carrier wave. The modulation process, fundamentally, is the multiplication of the signal carrying the information by a carrier wave of constant frequency and amplitude as shown in Fig. 26.27.

Let $e_s = A_s \sin \omega_s t$ and $e_c = A_c \sin \omega_c t$.

where $A_s, A_c =$ amplitude of signal and carrier respectively.

$\omega_s, \omega_c =$ frequency of signal and carrier respectively

$$\therefore \text{Output } e_{cm} = (A_s \sin \omega_s t) (A_c \sin \omega_c t) = \frac{A_s A_c}{2} \left[\cos(\omega_c - \omega_s)t + \cos(\omega_c + \omega_s)t \right] \dots (26.28)$$

The carrier frequency, ω_c , is usually considered greater than the signal frequency, ω_s . The carrier, signal and the modulated output waveforms are shown in Fig. 26.28.

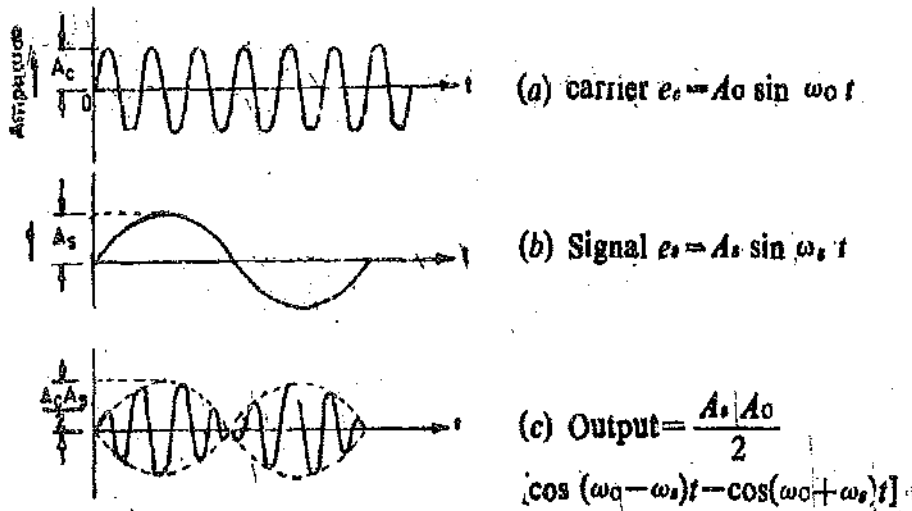

Fig. 26-28. Carrier, signal and modulated output waveforms.

From Eqn. 26-24, it is clear that the output represents a signal composed of two frequencies: $\omega_1 = \omega_c - \omega_s$ and $\omega_2 = \omega_c + \omega_s$ each of which has an amplitude of $A_c A_s / 2$. These frequencies ω_1 and ω_2 are called side frequencies. The frequency spectrum is shown in Fig 26-29.

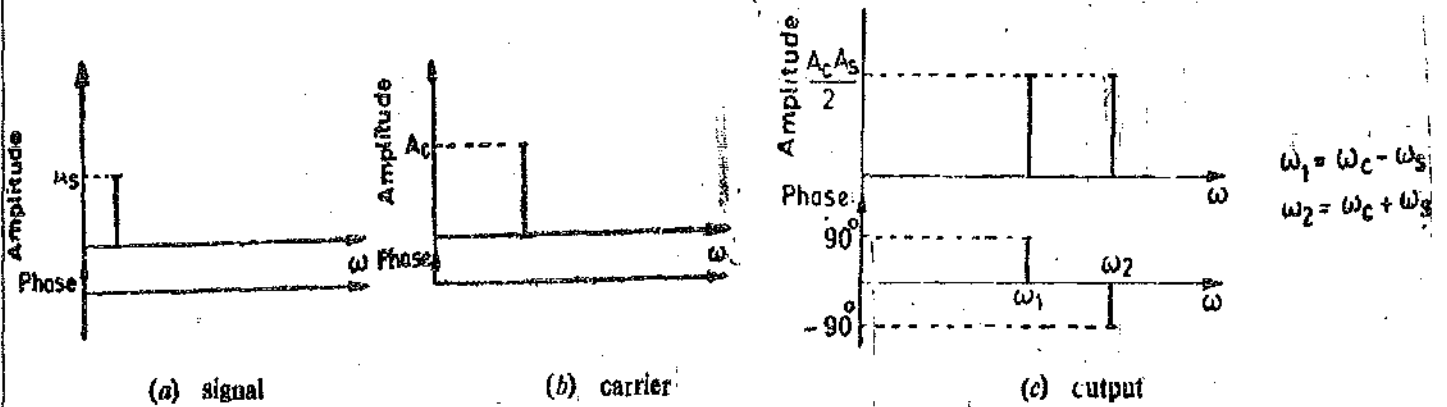
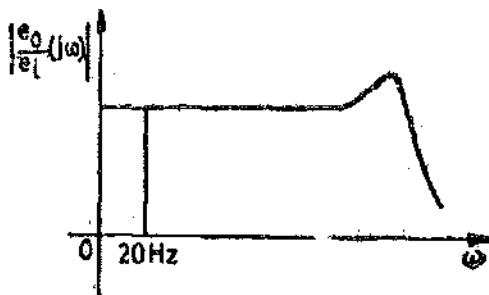

Fig. 26-29. Frequency spectrum of amplitude modulated signals.

The concept of amplitude modulation is used in carrier amplifiers. The output signals coming from transducers like strain gauges etc. are extremely small and therefore high gain amplifiers are used to produce perceptible outputs. A high gain a.c. amplifier is much easier to build than a d.c. amplifier as latter suffers from the disadvantage that they have inherent problem of drift. On the other



(a) Input-output configuration.



(b) D.C. amplifier characteristics.

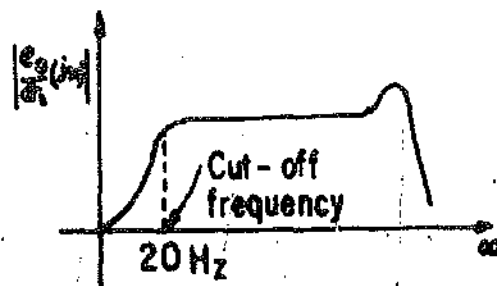

(c) A.C. amplifier characteristics.

Fig. 26-30. Characteristics of d.c. and a.c. amplifiers.

hand, an a.c. amplifier does not amplify static and slow varying dynamic inputs on account of their low frequency cut off. This is shown in Fig. 26'30. Thus, as such a.c. amplifiers are unsuitable for static and slow varying inputs. This problem can be overcome by the use of amplitude modulation techniques.

Supposing strain is to be measured with the help of a strain gauge. This strain gauge forms an arm of a Wheatstone bridge. The bridge is excited by a carrier voltage of 5 V at 3000 Hz as shown in Fig. 26'31. When a static strain is applied to the strain gauge, its resistance changes and an output varying at a frequency of 3000 Hz appears at the output terminals of the bridge.

This output can be easily amplified by an a.c. bridge. Supposing now we are interested in measurement of dynamic strains varying at a frequency of up to 20 Hz. The output of a bridge (and the input to the amplifier) will be an amplitude modulated wave having a frequency spectrum :

$$\omega_1 = 3000 - 20 = 2980 \text{ Hz to } \omega_2 = 3000 + 20 = 3020 \text{ Hz.}$$

This range of frequencies can be easily handled by an a.c. amplifier and are reproduced faithfully with a constant gain. This shifting of the information frequencies from one part of the frequency range to another forms the basis of many useful applications of amplitude modulation.

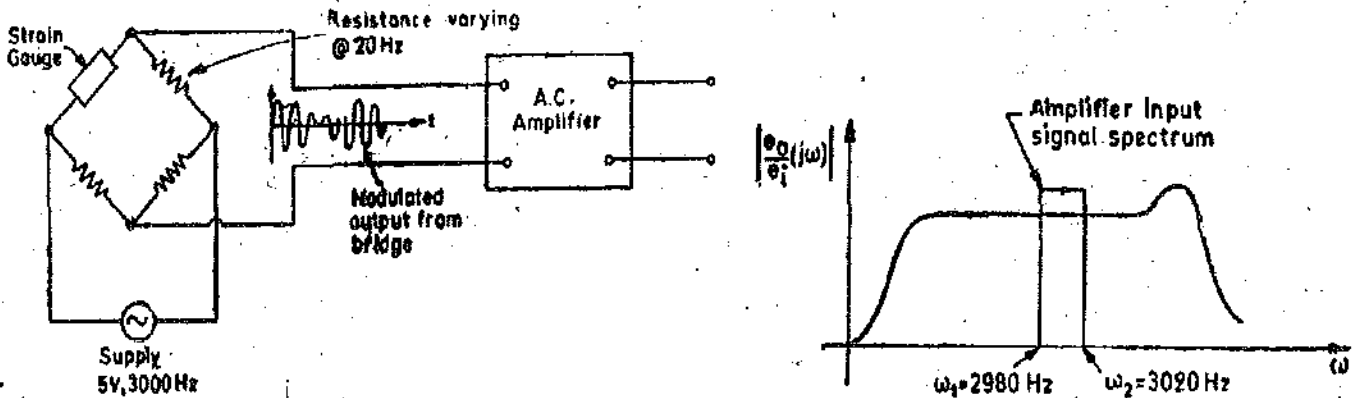

Fig. 26'31. Setup for measurement of dynamic strains and frequency response of an a.c. amplifier.

There is an additional advantage of using amplitude modulation. Supposing the wires leading from bridge to the amplifier circuit in Fig. 26'31 are subjected to a 50 Hz stray magnetic field produced by the surrounding wiring system and a.c. machines. This produces a 50 Hz noise or hum which is superimposed upon the desired signals. If d.c. amplifiers are used, this 50 Hz noise could easily be greater than the desired output signals. However, with the use of carrier system, this noise may easily be removed by simply designing the a.c. amplifier that does not respond to 50 Hz signal at all i.e., the amplification factor is almost zero for 50 Hz input as shown in Fig. 26'32. Since the desired band of frequencies is between 2980 and 3020 Hz, making the low frequency cut off of the amplifier greater than 50 Hz is quite easy.

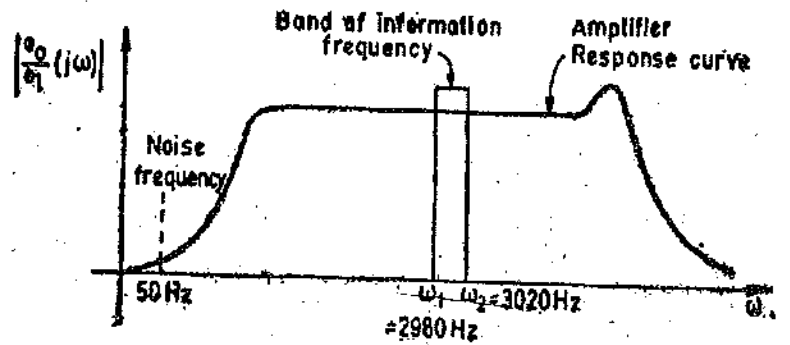

Fig. 26'32. Rejection of noise through amplitude modulation.

The signals encountered in measurement systems are not always pure sinusoidal signals. They may be periodic waves of any shape. Let the modulating signal be a periodic function $f_i(t)$. The periodic signal is expanded by Fourier series. Let the input consist of components having frequencies $\omega_1, \omega_2, \omega_3$, etc.

Fig. 26'33 shows the frequency spectrum of the output when the input is a periodic non-sinusoidal waveform. It is seen that we get a discrete spectrum containing the frequencies $\omega_0,$

$\omega_0 \pm \omega_1, \omega_0 \pm \omega_2, \omega_0 \pm \omega_3$ and so on. This means that each frequency component of modulating signal produces one pair of side band frequencies.

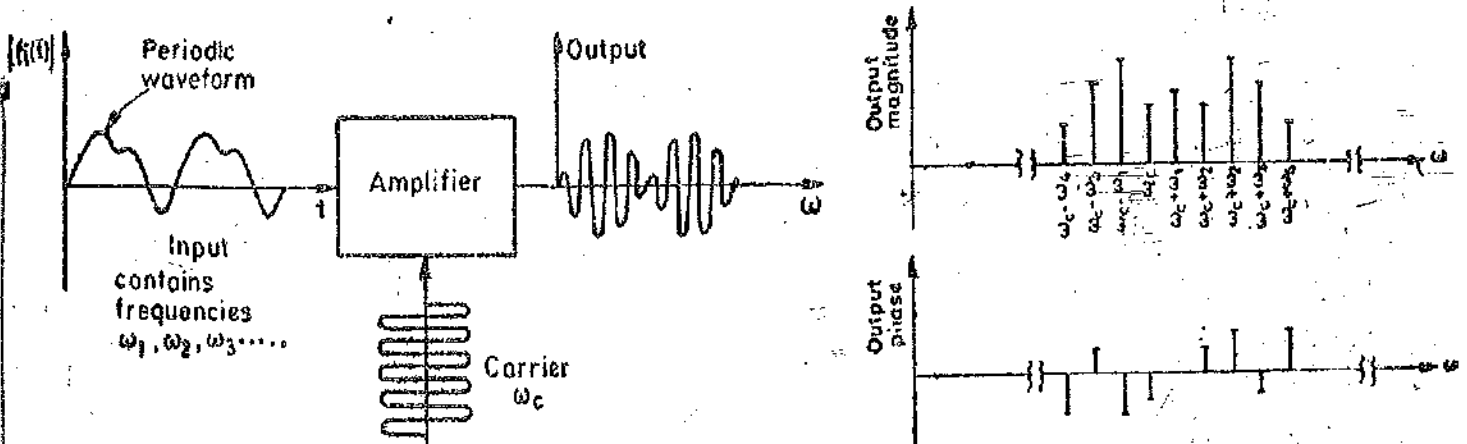

Fig. 26.33. Frequency spectrum when modulating signal is periodic non-sinusoidal.

For measurement system in which amplitude modulation is intentionally introduced in order to utilize the carrier-amplifier techniques, the carrier frequency, ω_c , must be considerably greater than any significant frequency present in the modulating signal. The carrier frequency is normally 5 to 10 times the significant frequency in the signal.

26.3. Amplitude Demodulation. When amplitude modulation is intentionally introduced in a system for data handling, it is used as an intermediate step. The amplitude modulated signal cannot be used to drive the final read-out system as such because it is not suitable for this purpose. In fact, the original form of the signal, which is the output of the transducers, should be applied to the final stage (*i.e.*, the data presentation stage) of the instrumentation system. The process required for recovery of original signal from the modulated waveform is called **demodulation** or **detection**. The detection or demodulation of an amplitude modulated signal requires rectification of the modulated signal followed by elimination of carrier frequency by proper filtering.

The demodulation may be : (i) half wave, (ii) full wave,
and (i) phase sensitive, (ii) non-phase sensitive as shown in Fig. 26.34.

The best form of representation of original signal is full-wave phase-sensitive demodulation.

The expression for the full-wave phase sensitive demodulated signal is :

$$\text{Demodulated signal output} = (A_s \sin \omega_s t) | A_c \cos \omega_c t |$$

Now $| A_c \cos \omega_c t |$ is a periodic function and is expanded by fourier series.

The frequency spectrum of the demodulated output signal is a discrete spectrum with frequency content at $\omega_s, 2\omega_c \pm \omega_s, 4\omega_c \pm \omega_s$, etc., as shown in Fig. 26.35. This output signal is then applied to a filter circuit of known frequency response. The filter should be so designed that the output is the signal in its original form. Thus the filter has to be designed that it passes the signal frequency, ω_s , (or band of frequencies in case the signal is a non-sinusoidal periodic waveform) without any distortion while the rejecting (producing almost no output for) frequencies $2\omega_c \pm \omega_s, 4\omega_c \pm \omega_s$, and so on. This is essential to recover back the original signal. It should be understood that modulation is a necessary intermediate process so that use be made of a.c. amplifiers which are free from problems of drift.

The filter connected to the output terminals is a Low Pass Filter *i.e.*, it passes the low frequency input faithfully while drastically attenuating (reducing the magnitude) of high frequencies. Thus the design of this low pass filter is made simpler if the passband (*i.e.*, band of frequencies which are reproduced faithfully and amplified) and the rejection band (*i.e.*, band of frequencies which are considerably attenuated) are widely separated. Now we want, the signals with frequency ω_s to be reproduced undistorted and the signals with frequencies $2\omega_c \pm \omega_s, 4\omega_c \pm \omega_s$, etc., to be rejected

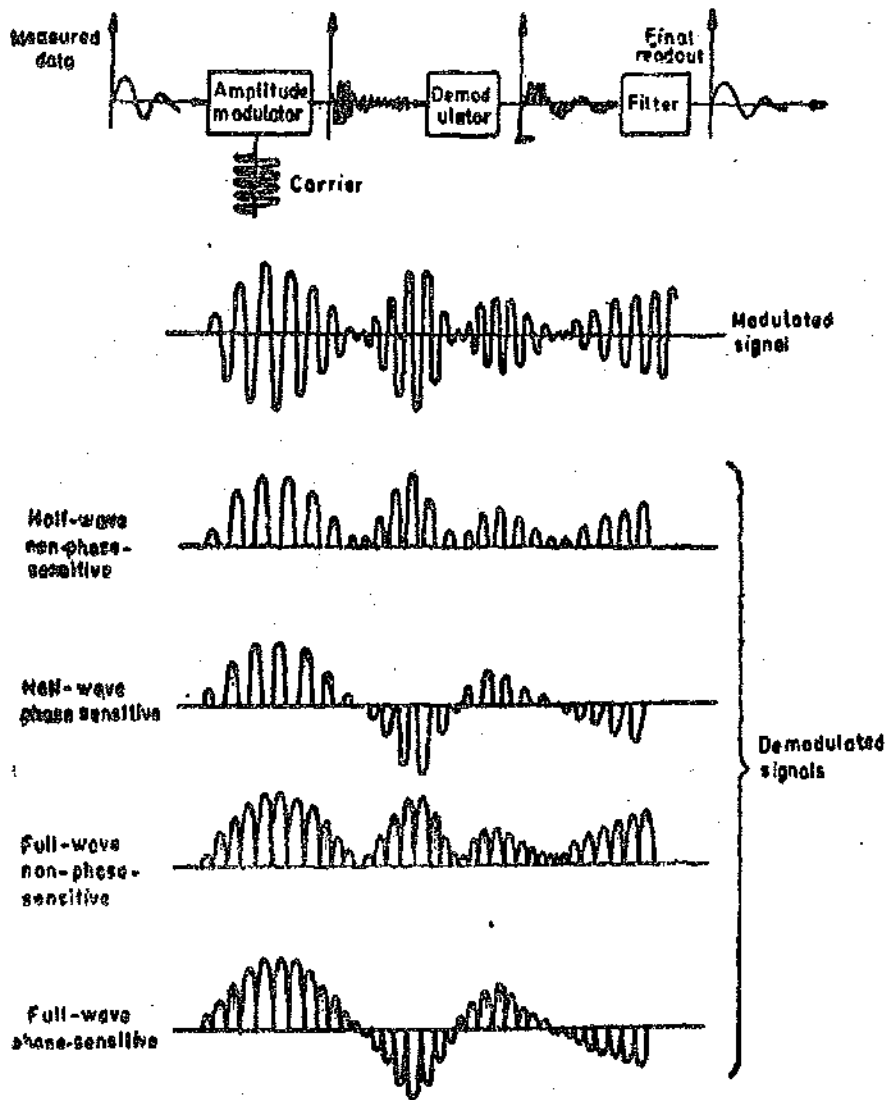

Fig. 26'34. Types of demodulation.

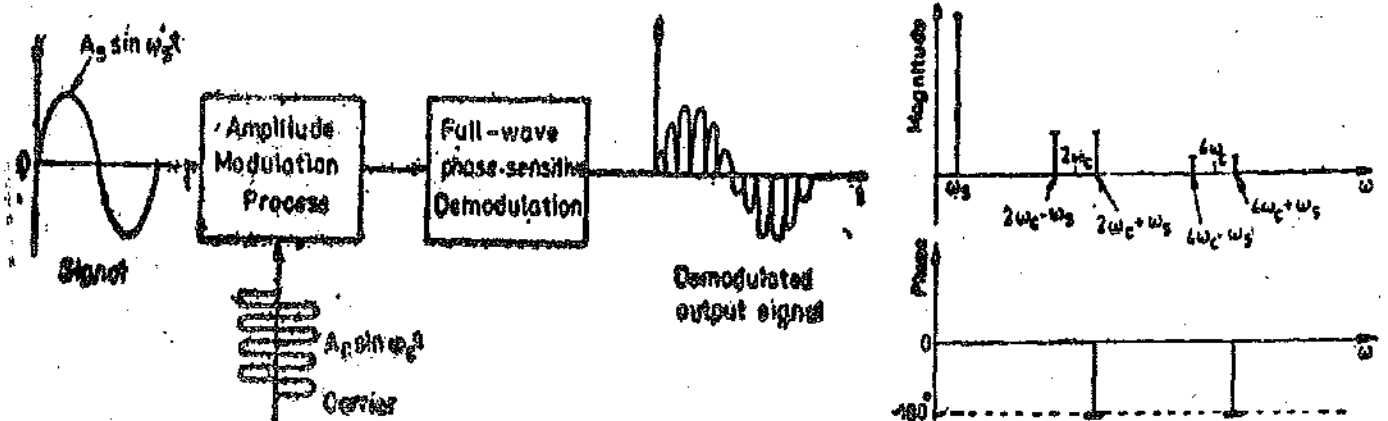
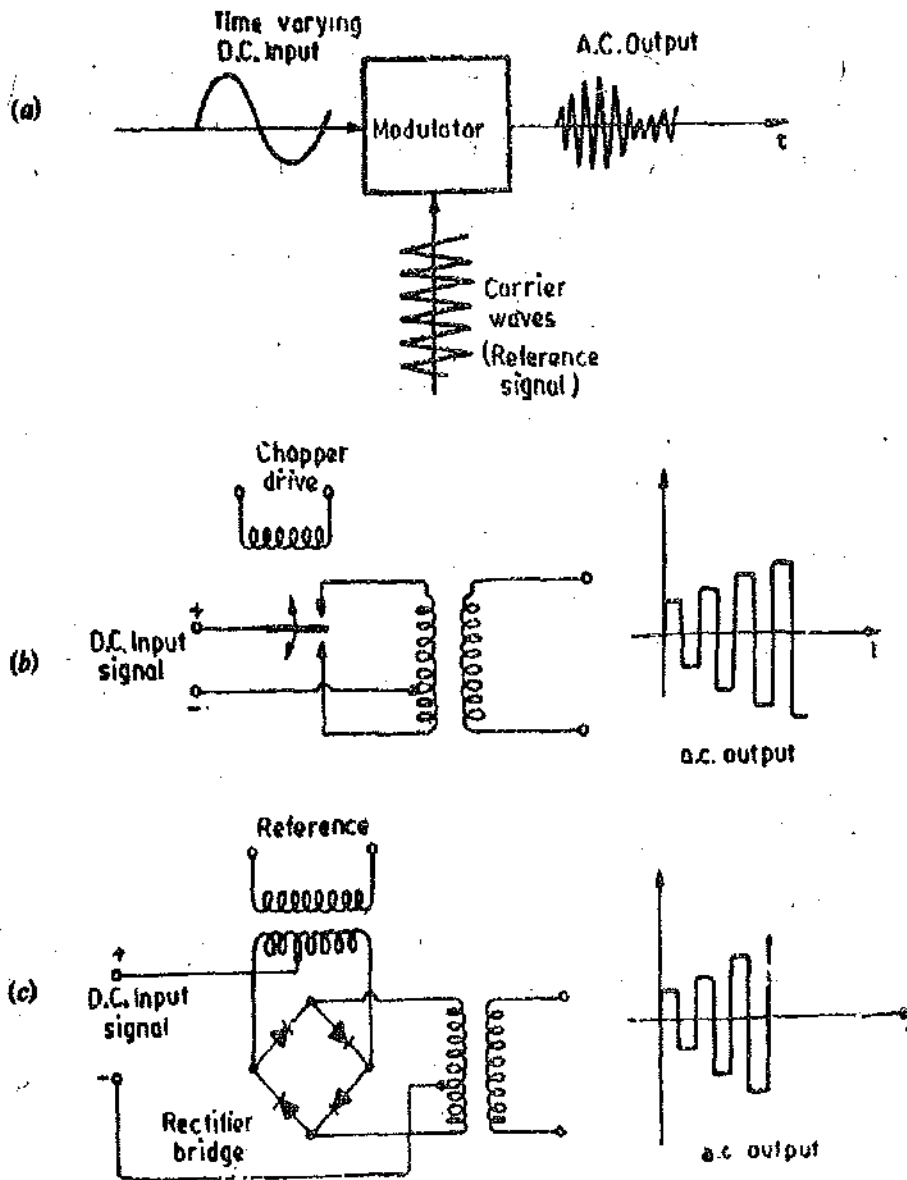

Fig. 26'35. Frequency spectrum of full wave phase-sensitive demodulator.

altogether. This requires that the carrier (frequency, ω_c) should be considerably larger than signal frequency ω_s in order that the passband and the rejection band are widely separated. Therefore, the carrier frequency, ω_c , is made atleast 5 to 10 times greater than the signal frequency, ω_s .

26.9. Amplitude Modulation and Demodulation Circuits For Measurement Systems. In many instrumentation systems, it is required to convert a.c. signals to d.c. signals and vice versa. This interconversion is necessary and also desirable for many applications.



(a) Basic configuration for a modulator, (b) Electromechanical chopper, (c) Semi-conductor modulator. Fig. 26.36. Amplitude Modulation.

The conversion from direct current to alternating current is a form of **Amplitude Modulation**. The conversion from alternating current to direct current is called **Demodulation** or **Detection**. Some circuits and the associated hardware needed for these conversions are described here.

The process of modulation may be performed by a number of devices. This process of modulation is shown by a block diagram in Fig. 26.36 (a). The carrier frequency should be atleast 5 to 10 times the highest harmonic of the input voltage. Electromechanical choppers are widely used as modulators. The carrier is a square wave of frequency between 50 to 400 Hz. The value of the carrier frequency is kept below 1000 Hz.

Fig. 26.36 (b) shows an electromechanical chopper to convert d.c. signal to an a.c. signal. In order to provide an isolation between the input and the output circuitry, a transformer is used. Electromechanical choppers cannot be used for high frequencies. For high frequency applications, solid state devices are used for chopping. A solid state chopper as used for high frequency applications as shown in Fig. 26.36 (c). This diagram shows a ring type diode modulator. The reference signal serves to switch the diodes from their conducting to non-conducting states, thereby giving an action similar to an electromechanical chopper but without any moving parts.

26.9.1. Input Modulator. A typical input modulator is shown in Fig. 26.37. The battery

represents the input d.c. signal. If the d.c. input is zero both diodes are driven by the oscillator signal alone. Since the two diodes are identical and primary winding of the transformer is centre tapped, there will be no output. During the positive half cycle of the oscillator input, both diodes are turned on. The currents i_1 and i_2 are equal, and since these currents flow in the opposite direction, and therefore there will not be any input to the transformer and hence no output. During the negative half cycle, both the diodes are non-conducting and hence there is no output. Therefore this modulator is called a **Balanced Modulator**.

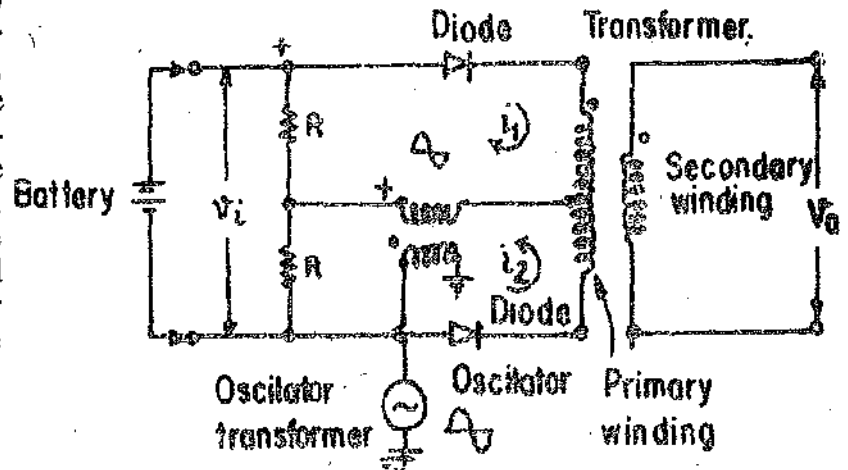

Fig. 26'37. Input modulator.

The waveforms for the currents under zero input signal condition are shown in Fig. 26'38 (a). The two currents i_1 and i_2 are half wave rectified sinusoids with equal maximum values. Suppose now a d.c. signal is applied to the input. A positive d.c. voltage as shown in Fig. 26'37 will produce plus-minus d.c. across resistors R .

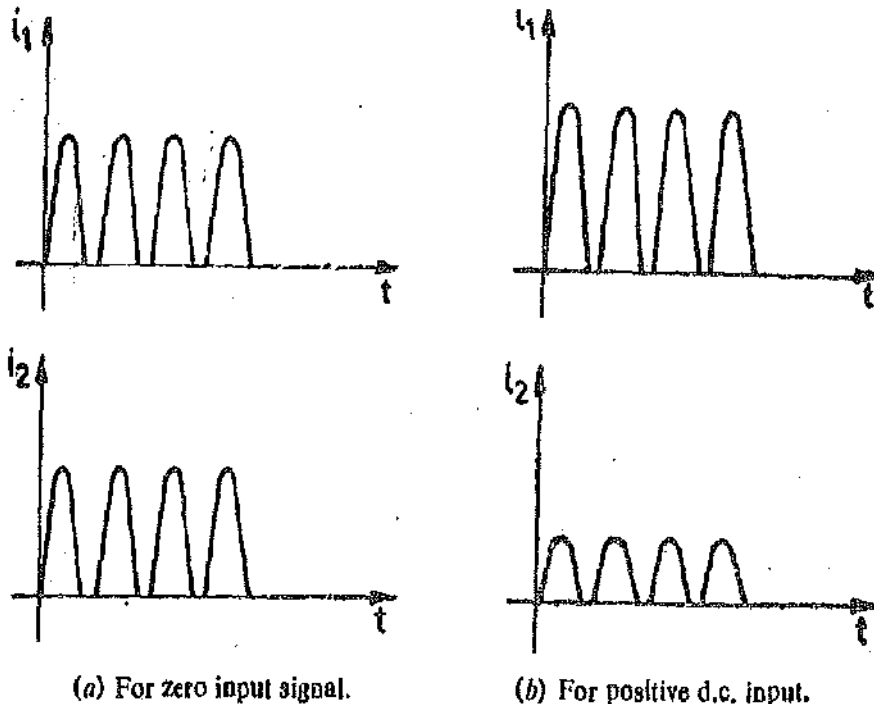
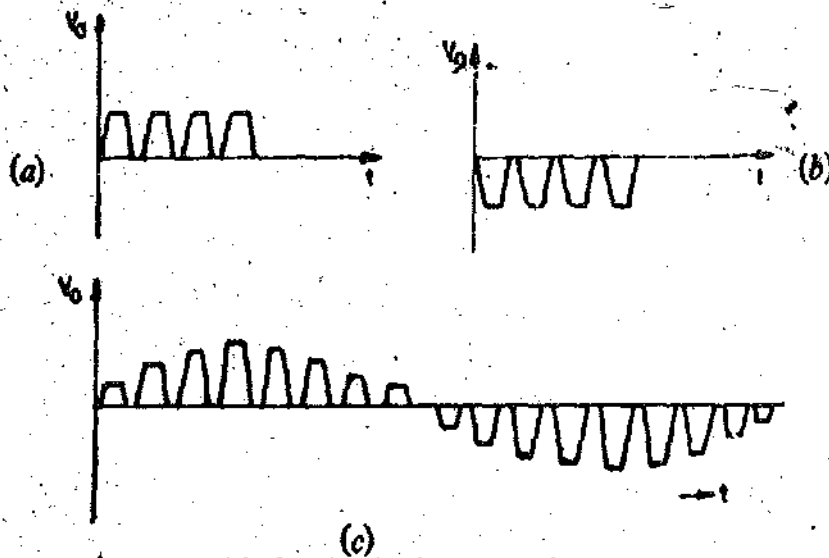

Fig. 26'38. Input modulator currents.

During the positive half cycle of the oscillator signals plus-minus d.c. voltages appears across the oscillator secondary. In upper loop, the d.c. voltage across the resistor R aids the oscillator signal, while, on the other hand the lower loop voltages are in opposition. On account of this reason the upper diode conducts heavily than the lower diode. This means that current i_1 is greater than i_2 as shown in Fig. 26'38 (b). On account of difference between i_1 and i_2 , a net flux is produced by the primary of transformer giving rise to an output voltage in the secondary winding. The magnitude of the output voltage is proportional to the difference between currents i_1 and i_2 and hence to the d.c. input signal. The output wave form is shown in Fig. 26'39. (a).

In case the polarity of the battery voltage in Fig. 26'37 (which represents the input signal) is reversed, the lower diode conducts more heavily than the upper one. The resulting output voltage waveform is shown in Fig. 26'39 (b). Thus a negative going output is produced.

In case, low frequency input signals are applied, an output waveform shown in Fig. 26'39 (c) is obtained. The output signals of modulator may be amplified prior to demodulation.



(a) Positive d.c. input (b) Negative d.c. input (c) Low frequency a.c. input
Fig. 26'39. Modulator output voltages.

26'9'2. Demodulator. A basic demodulator circuit is shown in Fig. 26'40. When there is zero input signal, only the oscillator signal drives the diodes. The capacitors are thus charged to the peak value of the oscillator signal. Since the voltages across the capacitors are opposite in polarity, the output voltage is zero. Thus for zero input voltage there is zero output.

Suppose now the input signal is a positive going voltage as shown in Fig. 26'41 (a). This input voltage signal will induce voltages across the secondary with the polarities indicated. The first half cycle of input signal is in phase with oscillator signal. Due to

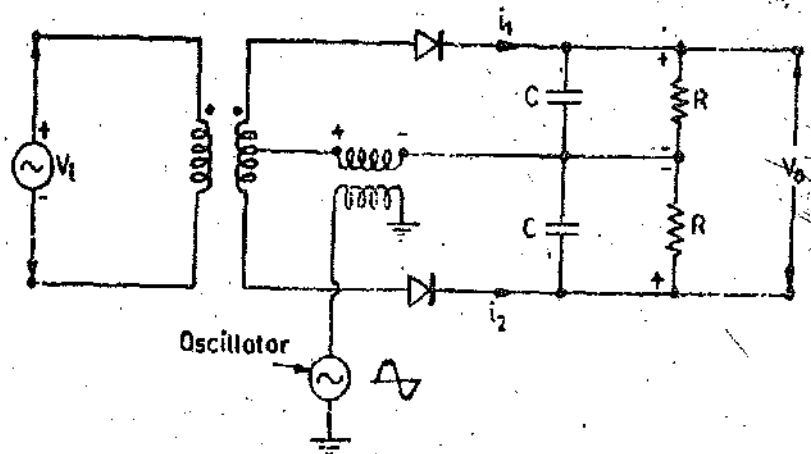
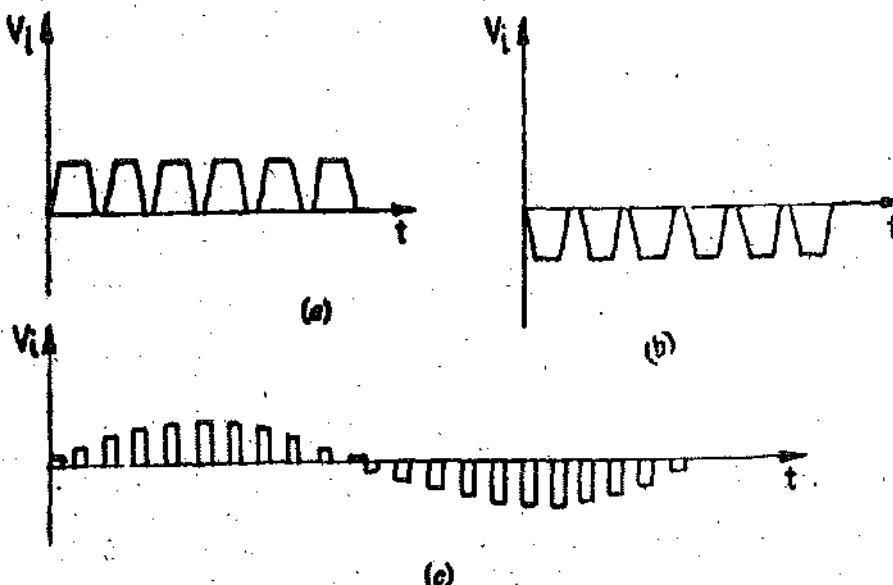

Fig. 26'40. Balanced demodulator.



(c)
Fig. 26'41. Input signals to demodulator.

this the upper loop is aiding and the lower loop is opposing. This means that the voltage across the upper capacitor is greater than that across the lower one. The output voltage is the difference between the capacitor voltages and hence will be positive. If the input to the demodulator is a negative signal, the output will be negative.

The output corresponding to a slow a.c. signal as shown in Fig. 26'41 (e) will be alternating.

In majority of the measurement systems, a phase sensitive demodulation is required, if the modulation is performed earlier so as to recover the algebraic sign of the original direction. This is essential because it becomes imperative to know the gain of the d.c. input signal. For example, if the output of a displacement transducer is fed to modulator and if a nonphase demodulator were used the information obtained would be the magnitude of displacement and not its direction. In

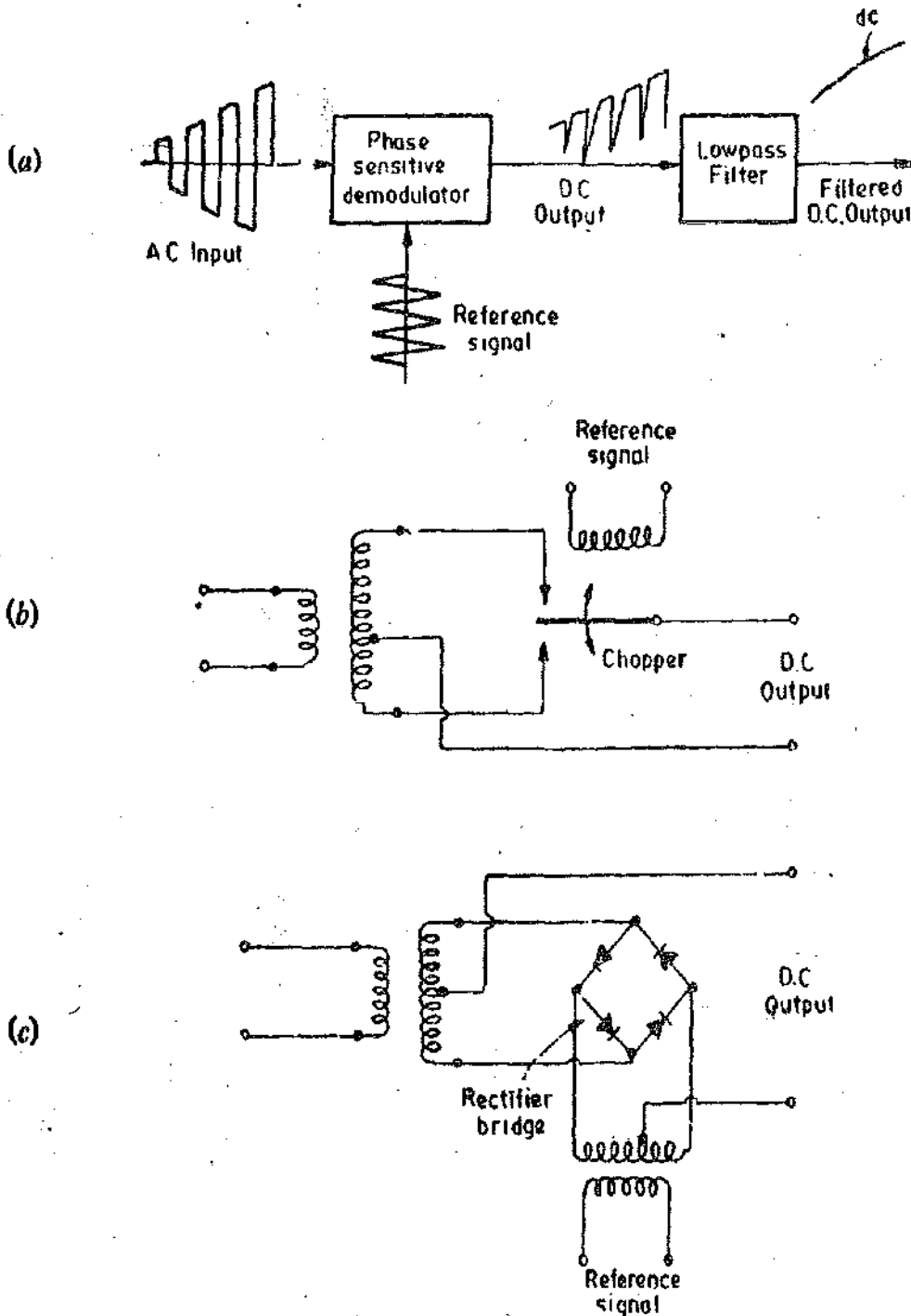

(a) Demodulator configuration (b) Chopper demodulator (c) Semi-conductor demodulator, Fig. 26'42. Phase sensitive demodulation,

order to have an indication whether the displacement increased or decreased, a phase sensitive demodulator has to be used. Fig. 26'42 shows a phase sensitive demodulator circuit.

In order that the sign of the original d.c. information be recovered, it is essential that the reference signal used to drive the modulator must also be used in the demodulator.

The modulators and demodulators described earlier used electro-mechanical choppers. Electronic chopper may be used to drive both the modulator as well as the demodulator circuits and also to achieve proper synchronization. This is shown in Fig. 26'43. In this circuit, the oscillator signal enters the input modulator and is modulated by the input d.c. signal. The output of the modulator is a signal of the same frequency as that of the oscillator. The peak value of this signal is proportional to the magnitude of the d.c. input.

In case, there is no d.c. input, the output is zero. The modulator is called balanced because there is no output in the absence of a d.c. signal. The modulator input is amplified by an a.c. amplifier. This output is demodulated to recover the original d.c. signal

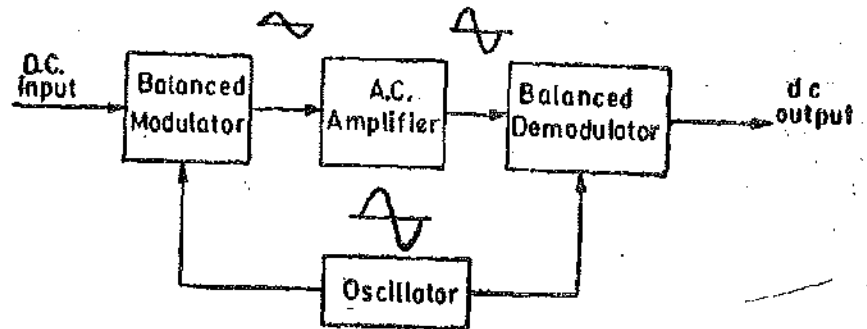

Fig. 26'43. Electronic chopper type d.c. amplifier.

The electronic system shown in Fig. 26'43 can also be used for low frequency input signals. In this case, the oscillator signal is modulated by the low frequency input signal.

The output of modulator is amplified and then demodulated to recover the signal of original frequency. However, in order to eliminate the noise from the output a lowpass filter has to be introduced at the output of the demodulator.

26'10. Filters. The signal originating from a transducer is fed to the signal conditioning equipment. In order to measure the output signal of the transducer originating on account of variations of a physical change, it is desirable that the output signal be reproduced faithfully. For faithful reproduction of signal it becomes necessary to eliminate any kind of spurious or unwanted signals which may get introduced into the system either at the transduction stage or at the signal conditioning stage. The filters are thus designed to pass the signals of wanted frequencies and to reject the signals of unwanted frequencies which may be unwanted harmonics and noise. The harmonics or noise may be due to some form of distortion.

26'11. Types of Filters

Filters may be of any physical form. They may be electrical, mechanical, pneumatic, hydraulic, acoustical etc. The most commonly used filters are electrical in form. The study of other filters may be carried out by analogies with electrical filters.

The filters may be classified as :

- (i) Low pass filters, (ii) High pass filters,
- (iii) Bandpass filters, and (iv) Band stop filters.

Let us consider a basic configuration of an electrical filter as shown in Fig. 26'44. The source is sinusoidal of variable frequency. The filter circuit may be so designed that some frequencies are passed from input to output of the filter with very little attenuation while other frequencies are greatly attenuated.

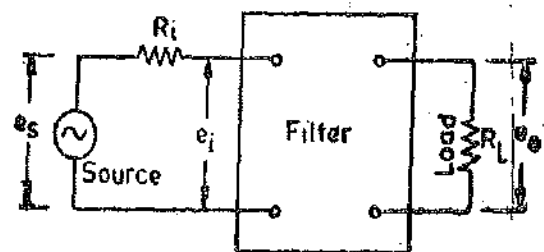

Fig 26'44. Basic configuration of an electrical filter.

The responses of various filters are shown in Fig. 26'45. These are ideal responses but cannot be achieved in actual practice.

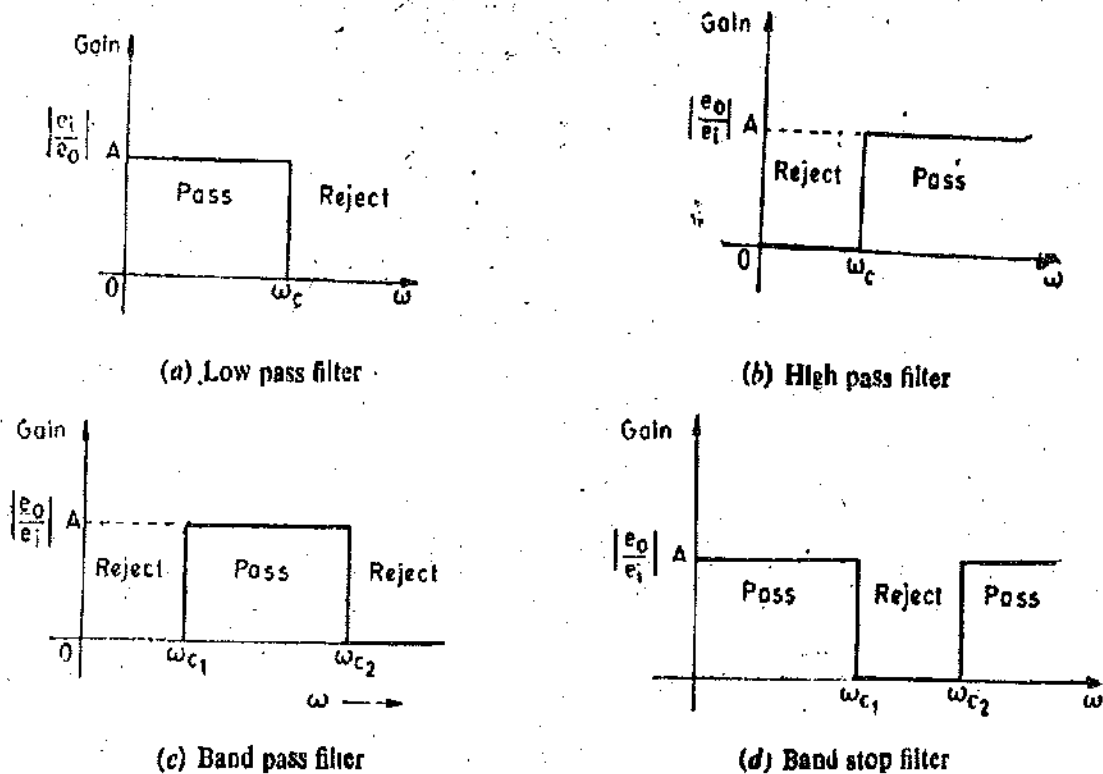

Fig. 26.45. Ideal characteristics of filters.

The ideal response of a Low Pass Filter is shown in Fig. 26.45 (a). The voltage gain is :

$$A = \left| \frac{e_o}{e_i} \right|$$

This gain is constant over a frequency range starting from 0 to a cut off frequency ω_c . The output of any signal having a frequency greater than ω_c , will be rejected altogether *i.e.* there will not be any output voltage corresponding to signals having frequency greater than ω_c , whatever their input magnitude be. The signals having a frequency range of 0 to ω_c will be faithfully reproduced with a constant gain of A . The output corresponding to signals above frequency ω_c is equal to zero *i.e.* they are rejected.

The characteristics of a High Pass filter are shown in Fig. 26.45 (b). The high pass filter has a gain of zero starting from zero frequency up to cut off frequency ω_c . Above the cut off frequency, the gain is constant and is equal to A . Thus signals of any frequency beyond ω_c will be faithfully reproduced with a constant gain A while signals having frequency below ω_c , will not be reproduced at all *i.e.* rejected.

The Band Pass filter shown in Fig. 26.45 (c), will faithfully reproduce signals falling within the range ω_{c1} and ω_{c2} faithfully while signals of frequency between 0 to ω_{c1} and of frequency greater than ω_{c2} will be rejected. There will be an output corresponding to signals having frequencies between ω_{c1} and ω_{c2} and there will not be any output for signals having frequencies below ω_{c1} and above ω_{c2} . Thus this filter passes a band of frequencies. Fig. 26.45 (d) represents the characteristics of a Band Stop filter. This filter rejects a particular band of frequencies from ω_{c1} to ω_{c2} while passing the signals of other frequencies (with a constant gain A) starting from 0 to ω_{c1} and ω_{c2} onwards. This is also called a Notch Filter.

The filters discussed above have ideal characteristics *i.e.* they have a sharp cut off but in actual practice, the characteristics as shown in Fig. 26.45 are not practically realizable. Therefore, we discuss below the characteristics of filters which can be practically realized.

26.11.1. Low Pass Filters. An electric low pass filter is shown in Fig. 26.46 (a). It is R-C network. At low frequencies, the capacitive reactance is very high and therefore the capacitor circuit

can be considered as an open circuit. Under these conditions $e_0 = e_i$ or the voltage gain is equal to

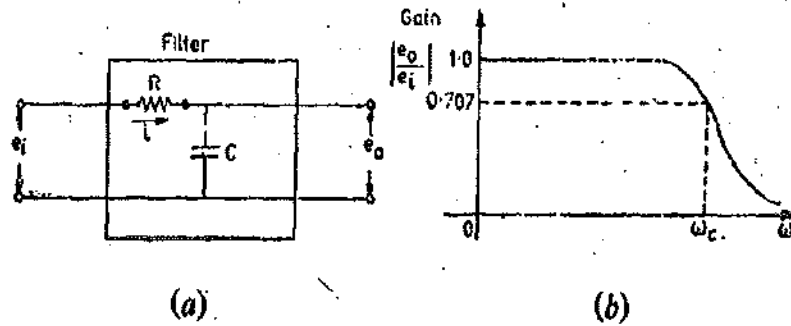

Fig. 26.46. Low pass R-C filter and its characteristics.

unity. At very high frequencies, the capacitive reactance is very low and therefore the output voltage e_0 is very small as compared with the input voltage e_i . Thus the gain is low and drops off gradually as the frequency is increased. This is shown in the characteristics of a low pass in Fig. 26.46 (b).

$$\text{The transfer function is } \frac{E_0}{E_i}(s) = \frac{1/sC}{R + 1/sC} = \frac{1}{1 + sRC} = \frac{1}{1 + s\tau} \quad \dots(26.25)$$

The sinusoidal transfer function of a low-pass filter is :

$$\frac{e_0}{e_i}(j\omega) = \frac{1}{1 + j\omega RC} = \frac{1}{1 + j\omega\tau} \quad \dots(26.26)$$

$$\therefore \text{Gain } A = \left| \frac{e_0}{e_i}(j\omega) \right| = \frac{1}{\sqrt{1 + (\omega RC)^2}} = \frac{1}{\sqrt{1 + (\omega\tau)^2}} \quad \dots(26.27)$$

The gain drops to 0.707 at cut-off frequency ω_c .

$$\therefore 0.707 = \frac{1}{\sqrt{1 + (\omega_c RC)^2}}$$

$$\text{or Cut off frequency } \omega_c = \frac{1}{RC} = \frac{1}{\tau} \text{ rad/s} \quad \dots(26.28)$$

$$\text{The cut off frequency in Hz is : } f_c = \frac{1}{2\pi RC} = \frac{1}{2\pi\tau} \quad \dots(26.29)$$

Let us have Bode plot of low pass RC filter. Consider the sinusoidal transfer function of Eqn. 26.26.

When $|j\omega\tau| \ll 1$, the gain is unity and the gain in terms of db is zero. The corner frequency is

$$\omega = 1/\tau = 1/RC.$$

For $|j\omega\tau| \gg 1$, the gain is $1/\omega\tau$ (i.e. $-20 \log \omega\tau$ in terms of db).

\therefore For frequencies greater than $1/\tau$, the asymptote has a slope of -20 db/decade or -6 db/octave. This is shown in Fig. 26.47.

Let us cite examples of use of a lowpass filters in measurement systems. Supposing a dynamic strain varying at a frequency of 1 Hz is being measured by a strain gauge bridge shown in Fig. 26.48 (a). There is an ample possibility that the output measurement circuit may pick up signals from 50 Hz power lines, thereby distorting the output from the strain gauge bridge. Therefore, it is essential that the 50 Hz signal be eliminated so that there is no spurious signal applied to the measurement circuit.

Fig. 26.48 (b) shows the input signal to the measurement system which contains the desired signal

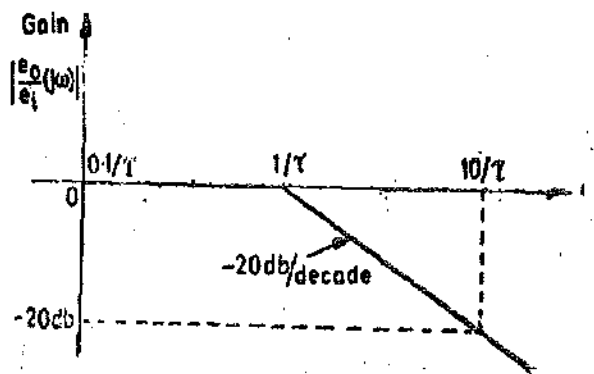
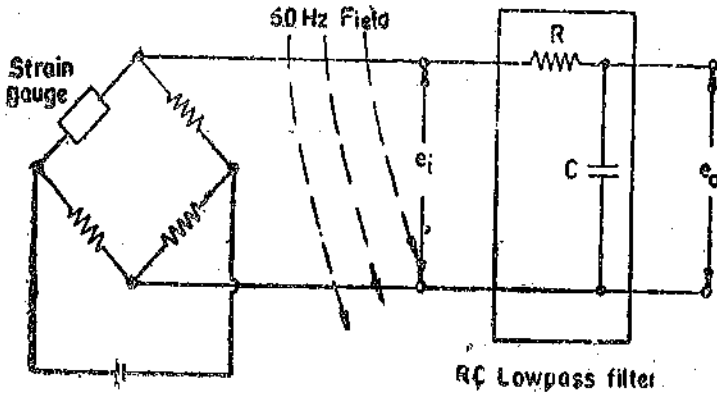

Fig. 26.47. Bode plot (magnitude) for a low-pass filter.

arising out on account of the change in strain (at a frequency of 1 Hz) plus the 50 Hz power line interfering signal. A low-pass RC filter can be designed to have a characteristics as shown in Fig. 26'48 (c) so that the desired signal (1 Hz in this case) is reproduced faithfully, while the high frequency signal of 50 Hz is greatly attenuated as shown in Fig. 26'48 (d).



Strain gauge bridge

(a) Strain gauge circuit

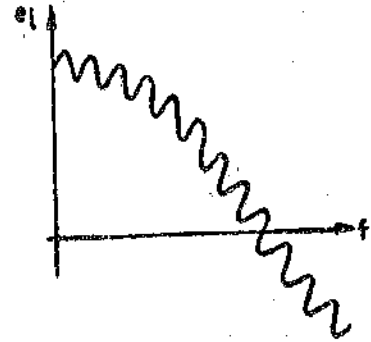

(b) Strain gauge signal plus the interfering signal

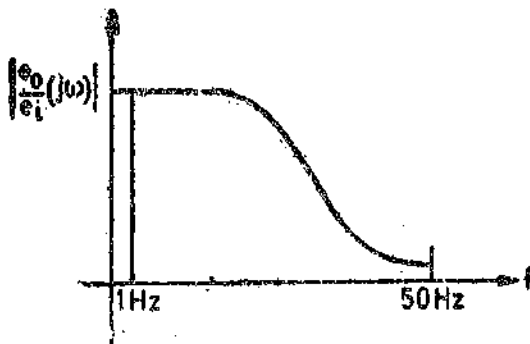

(c) Low-pass filter characteristics

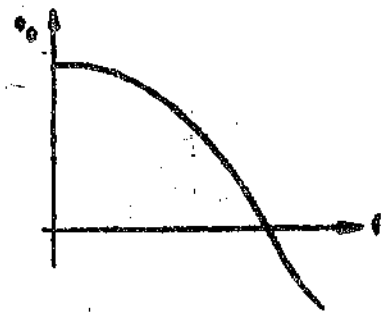

(d) Strain gauge signal

Fig. 26'48. Output filtering of strain gauge bridge signal by a low-pass filter.

Example 26'9. A simple RC low-pass filter is to be so designed that the output voltage be attenuated by 3 db at 50 Hz. Calculate the the time constant and suitable values of R and C.

Solution. The output voltage is attenuated by 3 db.

$$\therefore 10 \log \frac{E_o}{E_i} = -3 \quad \text{or} \quad \frac{E_o}{E_i} = 0.501$$

From Eqn. 26'26, for a low pass filter

$$\frac{E_o}{E_i} = \frac{1}{\sqrt{1 + \omega^2 \tau^2}} = \frac{1}{\sqrt{1 + (2\pi/50)^2 \tau^2}} = 0.501$$

or time constant $\tau = 5.5 \times 10^{-3}$ s. Now $\tau = RC$.

Take $R = 10 \text{ k}\Omega$, $\therefore C = \frac{5.5 \times 10^{-3}}{10 \times 10^3} \text{ F} = 0.55 \text{ }\mu\text{F}$.

26'13 2. Highpass Filter

An electric high-pass filter is shown in Fig. 26'49 (a).

The transfer function of a high-pass filter is given by :

$$\frac{E_o(s)}{E_i(s)} = \frac{R}{R + 1/sC} = \frac{sRC}{1 + sRC} = \frac{\tau s}{1 + \tau s} \quad \dots(26'30)$$

Sinusoidal transfer function $\frac{e_o}{e_i}(j\omega) = \frac{j\omega RC}{1 + j\omega RC} = \frac{j\omega\tau}{1 + j\omega\tau} = \frac{1}{1 + 1/j\omega\tau} \quad \dots(26'31)$

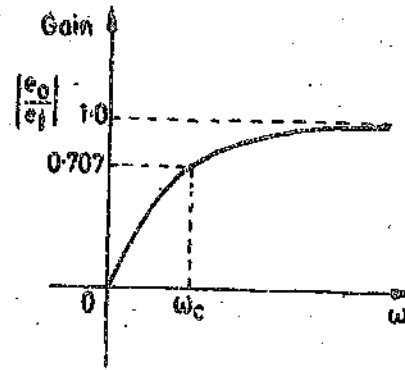
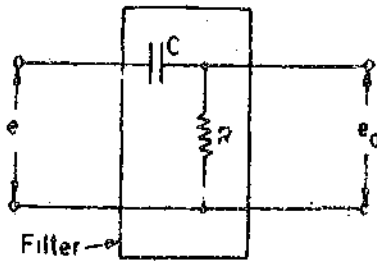

(a) (b)
Fig. 26.49. A high-pass filter and its response.

Gain $A = \left| \frac{e_o}{e_i}(j\omega) \right| = \frac{\omega\tau}{\sqrt{1+\omega^2\tau^2}} = \frac{1}{\sqrt{1+(1/\omega\tau)^2}} \dots(26.32)$

∴ When the frequency is low the gain is small and when the frequency is large, the gain approaches unity. Thus this circuit passes high frequencies while rejecting the low frequencies. The response of a high pass filter is shown in Fig. 26.49 (b).

when $\omega\tau \ll 1$ or $\omega \ll 1/\tau$, gain is 0 (in db). Therefore, the low frequencies are greatly attenuated. The corner frequency is $\omega = 1/\tau$ when $\omega\tau \gg 1$ or $\omega \gg 1/\tau$, the gain is $A = \omega\tau$.

The asymptote has thus a slope of 20 db/decade or 6 db/decade as shown in Fig. 26.50.

Cutoff frequency is : $f_c = 1/2\pi RC$

An application of highpass filters is described below :

A chopped radiometer is shown in Fig. 26.51 in a simplified form. The objective of this device is to sense the temperature, θ_s , of some object in terms of the infrared radiant energy it emits. The emitted energy is focussed on a detector, which responds to this type of radiation. This produces a change in θ_d , the temperature of the detector. Since the detector is sensitive to changes in temperature, it will produce a voltage e_i which is amplified to e_o by an amplifier. Thus if θ_s changes the temperature of the detector θ_d changes, with the result that e_i changes and consequently the output voltage e_o changes. An elementary set-up of this transducer is shown in Fig. 26.51.

The major problem with these devices is that the ambient temperature $\theta_{ambient}$ as well as the temperature of the source θ_s affect the temperature θ_d of the detector, thus affecting the output voltage e_o . The effect is serious because the radiant energy to be measured causes very small changes in θ_d . On the other hand even small changes in ambient temperature, $\theta_{ambient}$, may completely distort the output, thereby completely shrouding the output signal. A simple solution to this problem is the introduction of a rotating shutter between the radiant source and the detector so that the desired input is chopped or modulated, at a known frequency. The modulating frequency is chosen to be much higher than the frequencies at which the drift on account of temperature changes occur. The output voltage signal e_i of the detector is a superposed signal with slow changes on account of ambient temperature ($\theta_{ambient}$ variations and a high frequency signal whose amplitude varies in accordance with θ_s). As the desired and the interfering inputs are widely separated in frequency band, they can be conveniently and selectively filtered. For such an application, it is desired that the filter used should reject the slow varying interfering outputs on account of temperature variations, but passes fast varying signals on account of variations in θ_s . This calls for a high-pass filter. In fact such applications require the use of an a.c. amplifier. Since a.c. amplification, even otherwise needed, the use of an a.c. amplifier with low frequency cut-off solves both the problems i.e., the problem of attenuating a low frequency signal and amplification of a high frequency a.c. signal without distor-

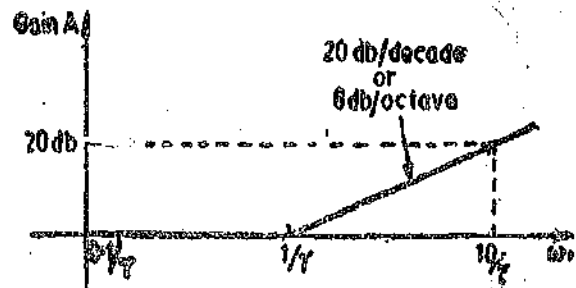

Fig. 26.50. Bode plot (Magnitude) for a high pass filter.

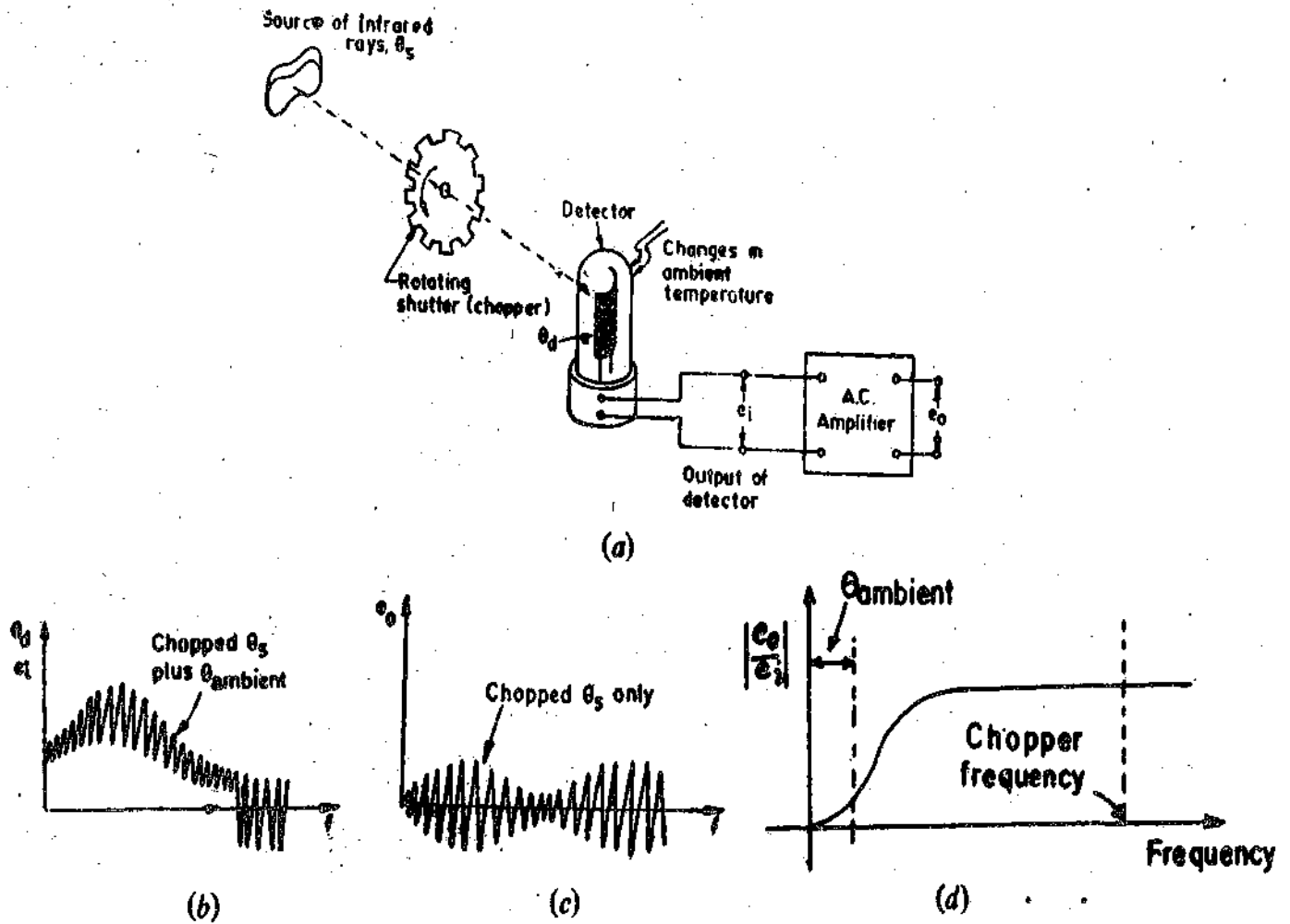

Fig. 26.51. A highpass filter for measurement infrared radiant energy.

tion. A wide frequency band is necessary and this is conveniently provided by the arrangement shown in Fig. 26.51.

26.11.3. Bandpass Filters

A simple bandpass filter can be constructed by cascading a low-pass and a high-pass filter as shown in Fig. 26.52 (a).

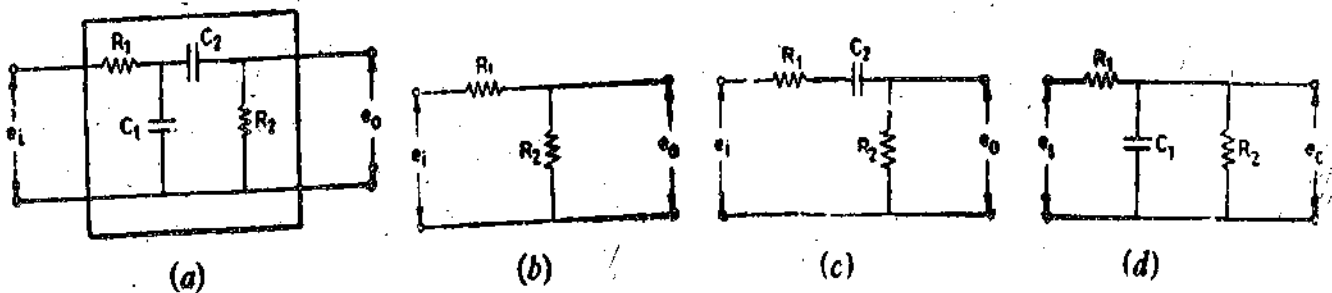

Fig. 26.52. RC passband filter.

There is a passband, with a lower cutoff frequency, f_{01} , and an upper frequency cutoff at f_{02} . In the passband, the circuit behaves like a voltage divider network shown in Fig. 26.52 (b). At frequencies below the passband, it behaves like a high-pass band filter as shown in Fig. 26.52 (c). (Since capacitor C_1 is short-circuited and capacitor C_2 behaves as an open circuit). Above pass band frequencies, the capacitor C_2 behaves as a short-circuited element and the circuit behaves like a lowpass filter as shown in Fig. 26.52 (d).

Thus if $R_2 \gg 10R_1$, and $f_{c2} > 10f_{c1}$.

The lower cutoff frequency is $f_{c1} = 1/2\pi R_2 C_2$ and the upper cutoff frequency is $f_{c2} = 1/2\pi R_1 C_1$

The low-pass and high-pass filters are connected in cascade, the transfer function is :

$$\frac{E_o(s)}{E_i(s)} = \frac{1}{(1+s\tau_1)} \times \frac{\tau_2 s}{(1+s\tau_2)} \quad \dots(26'33)$$

with $\tau_1 = R_1 C_1$ and $\tau_2 = R_2 C_2$ with $\tau_2 > \tau_1$.

The characteristics of a bandpass filter are shown in Fig. 26'53.

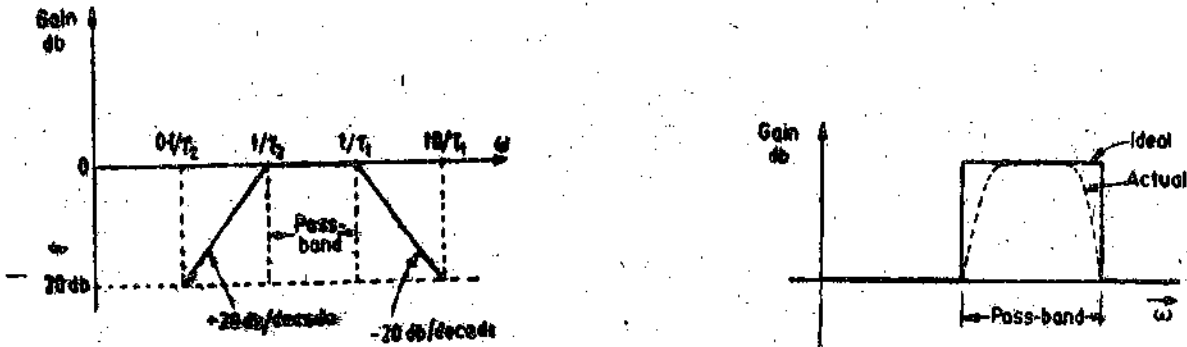

Fig. 26'53: Characteristics of a passband filter.

In this passband, the circuit behaves almost as a resistive network and therefore the gain in the passband is :

$$A = \frac{e_o}{e_i} = \frac{R_2}{R_1 + R_2} \quad \dots(26'34)$$

Example 26'10. A bandpass filter consists of two RC networks connected in cascade. The low pass filter consists of a resistor $R_1 = 10 \text{ k}\Omega$ and $C_1 = 100 \text{ pF}$ and the high pass filter consists of $R_2 = 1 \text{ M}\Omega$ and $C_2 = 0.01 \text{ }\mu\text{F}$. Find the lower and the upper cutoff frequencies and the passband gain.

Solution.

Passband gain
$$A = \frac{R_2}{R_1 + R_2} = \frac{1 \times 10^6}{1 \times 10^3 + 1 \times 10^6} = 0.99$$

Lower cutoff frequency $f_{c1} = \frac{1}{2\pi R_2 C_2} = \frac{1}{2\pi \times 10^6 \times (0.01) \times 10^{-6}} = 15.9 \text{ Hz.}$

Upper cutoff frequency $f_{c2} = \frac{1}{2\pi R_1 C_1} = \frac{1}{2\pi \times 10 \times 10^3 \times 100 \times 10^{-12}} \text{ Hz} = 159 \text{ kHz.}$

26'11'4. Band Rejection (band stop) Filters

A simple RC band rejection (band stop) filters use either a Wien Bridge circuit or a Twin 'T' circuit.

Twin T Band Stop filter. Fig. 26'54 shows a Twin T band stop filter. At very low and very

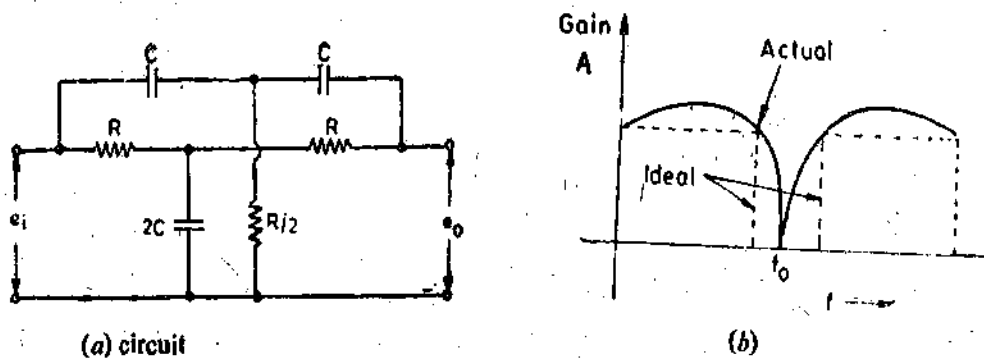

Fig. 26'54 Twin T Notch Filter

high frequencies, the gain is almost unity. Somewhere in between there is a frequency where the gain becomes zero.

The output at frequency, f_0 , is equal to zero. This type of filter is often called a notch filter because it completely rejects a particular frequency and attenuates a range of frequencies greatly while passing the frequencies below and above the notch. Frequency f_0 is called notch frequency.

Fig. 26.54 (b) shown the actual and ideal response of a notch filter.

Notch frequency $f_0 = 1/2\pi RC$... (26.35)

Example 26.11. Fig. 26.54 shows a parallel twin 'T' network. The resistance $R = 1 \text{ M}\Omega$. Find the value of C so that the notch frequency is 10 kHz.

Solution. From Eqn. 26.35, the notch frequency is $f_0 = 1/2\pi RC \text{ Hz}$.

\therefore Capacitance, $C = \frac{1}{2\pi R f_0} = \frac{1}{2\pi \times 1 \times 10^6 \times 10 \times 10^3} \text{ F} = 15.9 \text{ pF}$.

26.12. Filters With Cascaded Sections

The major disadvantage of using single section filters is that they do not have a sharp cutoff. The cutoff is only 20 db/decade (or 6 db/octave) with the result that the unwanted frequencies are not attenuated sufficiently. The roll off is so gentle that filters do not give a sharp distinction between the frequencies that are passed and those which are rejected. The sharpness of the cutoff may be increased by connecting more sections in cascade. This method, however, suffers from the disadvantage, that the addition of more stages there is considerable attenuation in the passband.

Fig. 27.55 shows 2-stage filters.

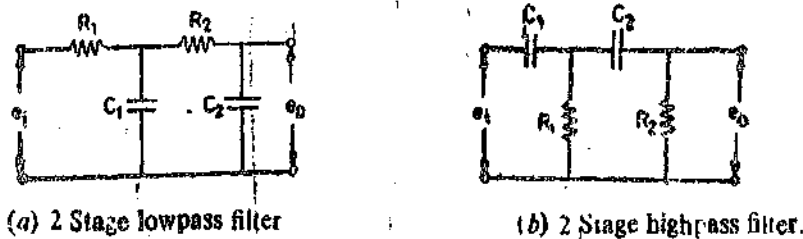

Fig. 26.55. RC filter sections connected in cascade.

26.13. LC Filters

In order to have sharper cutoff and also prevent any attenuation in passband, LC, filters are used.

Fig. 27.56 shows some basic configurations of Low Pass LC Filters. At low frequencies, the inductance presents a short while the capacitance is open circuited with output almost equal to input. At high frequencies the inductance presents a high series impedance while the capacitance is short circuited. This gives a zero output. Therefore the circuits are basically low pass filters.

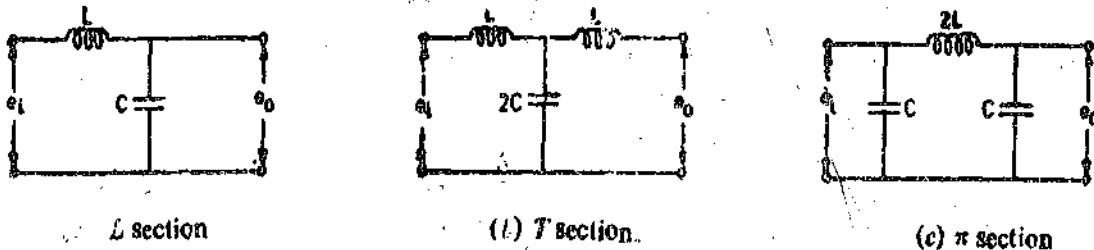

Fig. 26.56. Basic configuration of LC lowpass filters.

Characteristics resistance $R_0 = \sqrt{L/C}$... (26.36)

The source and the load with which LC filters are used must have the same resistance values as R_0 .

Cut-off frequency $f_c = 1/2\pi \sqrt{L/C}$... (26.37)

$$= 1/2\pi R_o C \quad \dots(26'38)$$

Attenuation in the stopband = $8.7 n \alpha$ db ... (26'39)

where $\alpha = 2 \cosh^{-1} (f/f_c)$ and $n =$ number of stages

Fig. 26'57 shows different configurations of highpass LC filters.

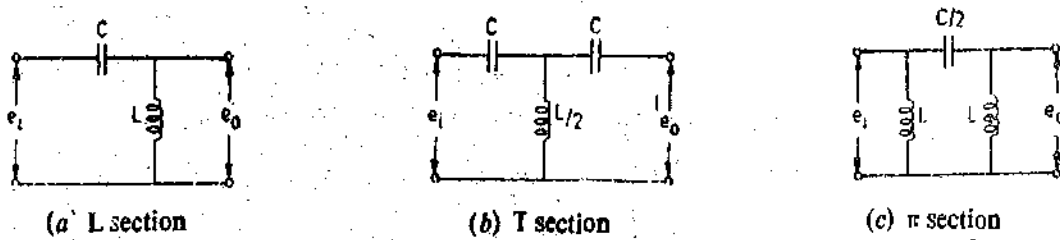

Fig. 26'57. Basic configurations of Highpass LC Filters.

At low frequencies the capacitance presents an open circuit and inductance presents a short and therefore the output is almost zero. At higher frequencies, the capacitor is almost shorted while inductance presents an open circuit with the result that the output is almost equal to input.

$\alpha = 2 \cosh^{-1} (f_o/f)$ for high pass filters.

Example 26'12. A basic low pass T section filter uses an inductance of 1000 mH and a capacitance of 5000 pF. Find the size of the load and the source resistances that should be used with this filter. Find also the cutoff frequency.

Solution. The values of L and C used in Eqn. 26'37 refer to the values of the basic L section filter. The T section is made up of two back to back L sections. Therefore shunt capacitance of the T section is $2C$. Hence, $2C = 5000$ pF or $C = 2500$ pF

Characteristics resistance $R_o = \sqrt{L/C} = \sqrt{\frac{1000 \times 10^{-3}}{2500 \times 10^{-12}}} \Omega = 20$ k Ω .

Cutoff frequency $f_o = \frac{1}{2\pi\sqrt{LC}} = \frac{1}{2\pi\sqrt{1000 \times 10^{-3} \times 2500 \times 10^{-12}}} = 3180$ Hz. The source and the load resistances should also be equal to 20 k Ω .

Example 26'13. Design a low pass LC filter with a cutoff frequency of 500 Hz with a load of resistance 16 Ω . Find out the attenuation at 1000 Hz (an octave above cutoff frequency).

Solution. The characteristic resistance should be equal to load resistance $\therefore R_o = 16 \Omega$.

Cutoff frequency $f_o = \frac{R_o}{2\pi L}$

\therefore Inductance $L = \frac{R_o}{2\pi f_o} = \frac{16}{2\pi \times 500} = 5.1 \times 10^{-3}$ H = 5.1 mH.

Capacitance $C = \frac{1}{2\pi R_o f_o} = \frac{1}{2\pi \times 16 \times 500} \approx 20 \times 10^{-6}$ F = 20 μ F.

A single stage LC low pass filter is shown in Fig. 26'58.

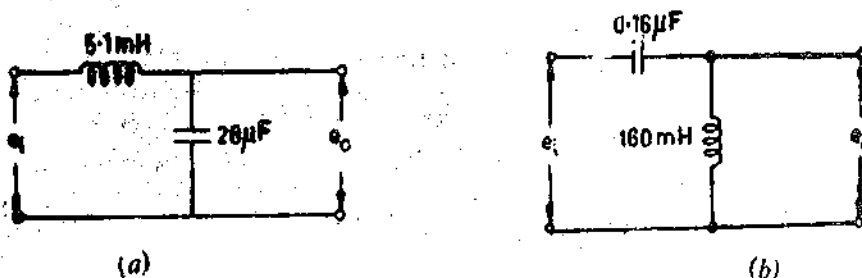

Fig. 26'58. LC filters.

$$\alpha = 2 \cosh^{-1} (f/f_0) = 2 \cosh^{-1} (1000/500) = 2.64$$

Attenuation at a 1000 Hz = $8.7 \pi \alpha = 8.7 \times 1 \times 2.64 = 23 \text{ db}$.

This CL filter gives a much sharper cutoff of 23 db/octave instead of 6 db/octave given by a simple RC filter. If a more sharper cutoff is desired more sections can be added in cascade.

Example 26.13. Design a high-pass LC filter with a load resistance of 1000 Ω and a cutoff frequency of 1000 Hz. What is the attenuation at one octave below the cutoff frequency i.e., at 500 Hz. If there are two stages what will be attenuation at 500 Hz?

Solution. The characteristics resistance should be equal to the load resistance. $\therefore R_0 = 1000 \Omega$.

$$\text{Inductance } L = \frac{R_0}{2\pi f_0} = \frac{1000}{2\pi \times 1000} = 0.16 \text{ H} = 160 \text{ mH}.$$

$$\text{Capacitance } C = \frac{1}{2\pi R_0 f_0} = \frac{1}{2\pi \times 1000 \times 1000} \text{ F} = 0.16 \mu\text{F}.$$

A single section LC high pass filter is shown in Fig. 26.58(b).

For a high-pass filter $\alpha = 2 \cosh^{-1} (f_0/f) = 2 \cosh^{-1} (1000/500) = 2.64$

\therefore For a single stage high pass filter :

Attenuation at 500 Hz is $= 8.7 \times 1 \times 2.64 = 23 \text{ db}$.

In case, there are two stages connected in cascade, the attenuation at 500 Hz is :

$$= 8.7 \times 2 \times 2.64 = 46 \text{ db}.$$

Thus the low frequencies are considerably attenuated.

Example 26.14. The primary winding of an LVDT is excited by a 10000 Hz source. The input displacement to the core has a highest frequency content of 1000 Hz. The output of the LVDT is connected to a phase sensitive demodulator which in turn is connected to an RC lowpass filter. Find the time constant of the filter in case the ripple due to the demodulated signal is limited to 5 per cent. Is the arrangement satisfactory? If not, suggest a better arrangement for the filter circuit.

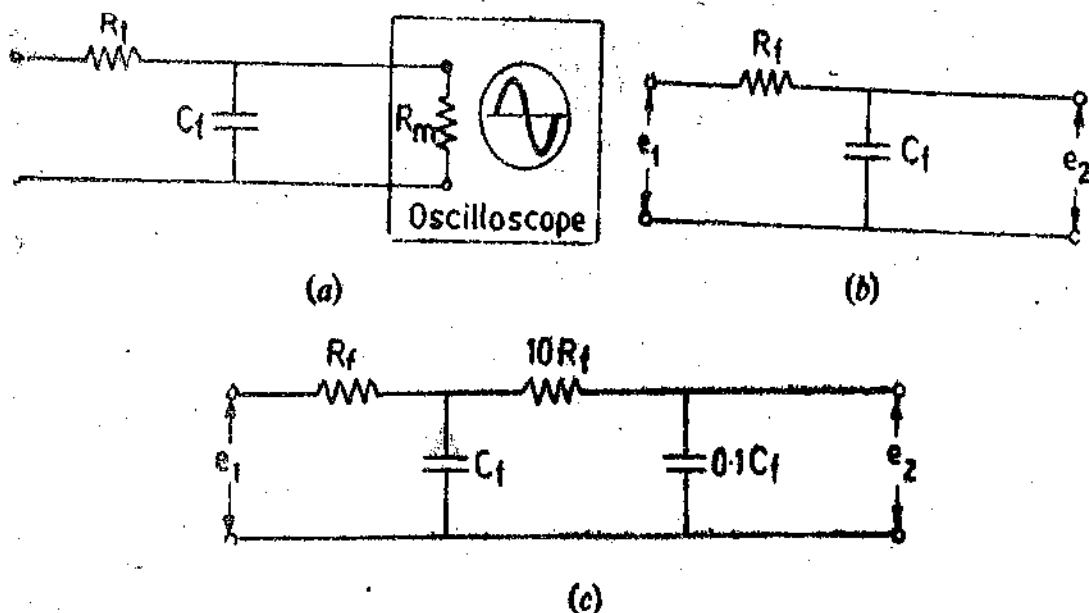

Fig. 26.59

Solution. The excitation frequency of the LVDT 10,000 Hz and that of the signal is 1000 Hz. Therefore,

$$\omega_s = 2\pi \times 10,000 \text{ rad/s}; \text{ and } \omega_r = 2\pi \times 1000 \text{ rad/s}.$$

The frequency band produced by the demodulation process are :

$$2\omega_c - \omega_s = 2\pi(2 \times 10,000 - 1000) = 2\pi(19,000) \text{ rad/s.}$$

$$\text{and } 2\omega_c + \omega_s = 2\pi(2 \times 10,000 + 1000) = 2\pi(21,000) \text{ rad/s.}$$

The filter circuit is shown in Fig. 26.59 (b).

Therefore, if we desire that the ripple due to frequencies 19,000 Hz and more should not be more than 5 per cent, the time constant for the filter can be found as under :

$$0.05 = \frac{1}{\sqrt{1 + (2\pi \times 19000 \tau_f)^2}}$$

or Filter time constant $\tau_f = 0.167 \times 10^{-3} \text{ s} = 0.167 \text{ ms.}$

The amplitude ratio at the highest motion frequency of 1000 Hz is given by :

$$M = \left| \frac{e_2}{e_1} (j\omega) \right| = \frac{1}{\sqrt{1 + \omega^2 \tau_f^2}} = \frac{1}{\sqrt{1 + (2\pi \times 1000 \times 0.167 \times 10^{-3})^2}} = 0.69$$

$$\text{Phase shift } \phi = \tan^{-1} \omega \tau_f = -\tan^{-1} (2\pi \times 1000 \times 0.167 \times 10^{-3}) = -46.4^\circ.$$

Thus this filter has an amplitude ratio of 0.69 and a phase shift of -46.4° . This will distort the high frequency portion of the input displacement x_i considerably. Therefore, this filter is not suited for this particular application. It has a cut-off rate of -20 db/decade . A filter of sharper cut-off rate is desired.

A more suitable proposition would be to use a double RC filter as shown in Fig. 26.59 (c). For this filter two RC filters are connected in cascade with same time constant.

$$\text{The frequency response is : } \frac{e_2}{e_1} (j\omega) = \frac{1}{(1 + j\omega R_f C_f)^2}$$

This filter gives a cut-off rate of -40 db/decade .

\therefore The ratio of output voltage to input voltage is :

$$M = \frac{1}{1 + \omega^2 R_f^2 C_f^2} = \frac{1}{1 + \omega^2 \tau_f^2}$$

$$\therefore 0.05 = \frac{1}{1 + (2\pi \times 19000 \times \tau_f)^2} \quad \text{or } \tau_f = 36.5 \times 10^{-6} \text{ s} = 36.5 \mu\text{s.}$$

The amplitude ratio for a frequency of 1000 Hz is :

$$M = \frac{1}{1 + (2\pi \times 1000 \times 36.5 \times 10^{-6})^2} = 0.95$$

$$\text{Phase angle } \phi = -2 \tan^{-1} \omega \tau_f = -2 \tan^{-1} (2\pi \times 1000 \times 36.5 \times 10^{-6}) = -26^\circ.$$

26.14. Input Circuits

The following types of input circuits are used for signal conditioning of electrical transducers. Though the list is not complete but it includes most of the important items. The input circuits used are :

- | | |
|--|--|
| (i) Simple current sensitive circuits, | (ii) Ballast circuits, |
| (iii) Voltage dividing circuits, | (iv) Voltage balancing potentiometer circuits. |
| (v) Bridge circuits, | and (vi) Resonant circuits. |

26.15. Current Sensitive Circuits

Fig. 26.60 shows a simple current sensitive circuit. This input circuit uses the flow

through a passive resistance transducer as an indication of the value of the resistance. The transducer may employ any one of the various forms of variable resistance elements. The resistance of transducer changes when there is a change in the physical quantity which is being measured, thereby causing a change in current. This current is sensed and the physical quantity is therefore measured or recorded. The measurement or the recording device may be calibrated to read the physical quantity directly.

The output current depends upon the input voltage e_i and therefore in order to maintain the calibration of the current sensitive circuit, the value of e_i should be kept constant.

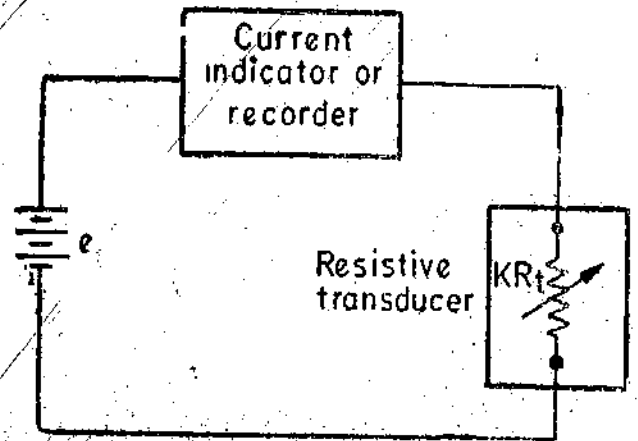
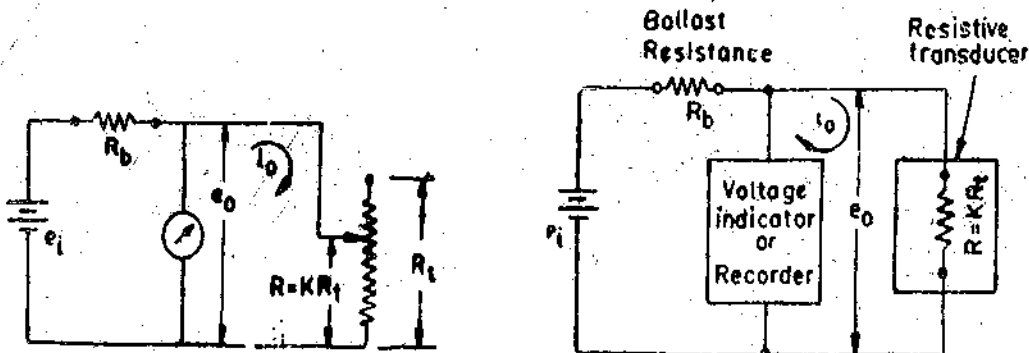

Fig. 26'60. Current sensitive circuit.

26'16. Ballast Circuit

A ballast circuit is only a simple variation of the current sensitive circuit. In this case a voltage sensitive device is connected across the transducer in place of a series connected current sensitive device. The circuit is also called a voltage sensitive circuit.

Figs. 26'61 (a) and (b) show a Ballast circuit. The circuit includes a series resistance, R_b , which is called ballast resistance.



(a) Schematic diagram.

(b) Circuit diagram

Fig. 26'61. Ballast circuit (voltage sensitive circuit).

A ballast resistance is a must in a voltage sensitive circuits since in the absence of the ballast resistance, R_b , the voltage device will always record the same voltage i.e. e_i irrespective of the transducer resistance.

It is assumed that the voltage measuring or recording device has an infinite resistance so that it does not draw any current.

Let R_t = maximum resistance of transducer.

$R = KR_t$ = resistance of transducer when measuring a physical quantity.

The value of K may vary from 0 to 1 and is a function of the magnitude of the input signal.

$$\text{Output current } i_0 = \frac{e_i}{R_b + R} = \frac{e_i}{R_b + KR_t} \quad \dots(26'40)$$

$$\text{Output voltage } e_0 = i_0 R = \frac{e_i}{R_b + R} \cdot R = \frac{e_i}{R_b + KR_t} \times KR_t \quad \dots(26'41)$$

$$\frac{e_0}{e_i} = \frac{KR_t}{R_b + KR_t} = \frac{KR_t/R_b}{1 + (KR_t/R_b)} \quad \dots(26'42)$$

For a voltage sensitive circuit ratio e_0/e_i is indicative of output and K is indicative of the magnitude of input signal. It is clear from Eqn. 26'42 that input-output relationship for a voltage sensitive (ballast) circuit is non-linear.

$$\text{Sensitivity } S = \frac{de_0}{dR} = \frac{e_i R_b}{(R_b + R)^2} = \frac{e_i R_b}{(R_b + KR_t)^2} \quad (26'42)$$

It is clear from Eqn. 26'43, that the sensitivity is different for different values of ballast resistance, R_b . In order to design the circuit so that sensitivity S is maximum an optimum value for R_b has to be obtained. This is obtained by differentiating S with respect to variable R_b .

$$\frac{dS}{dR_b} = \frac{e_i(R - R_b)}{(R_b + R)^3} = \frac{e_i(KR_t - R_b)}{(R_b + KR_t)^3}$$

$$\text{The maximizing condition is : } \frac{dS}{dR_b} = \frac{e_i(KR_t - R_b)}{(R_b + KR_t)^3} = 0$$

\therefore We get $R_b = KR_t$ for maximum sensitivity.

The value of R_b , must be based upon a compromise since R_b , a constant, cannot always have the value of KR_t , a variable. But since the resistance of the transducer KR_t is variable, we may select the value of R_b only for the range of $R = KR_t$ where the sensitivity is to be maximum.

The advantage of the voltage sensitive circuit over a current sensitive circuit is that a voltage measurement is easier to perform than current measurement.

The disadvantages of a voltage sensitive circuit are :

(i) Changes in the input voltage e_i , results in greater change in output than similar changes in K (which are on account of change in input signal). Therefore for constancy of calibration, the input voltage e_i should be kept absolutely constant. This requires a voltage regulated source.

(ii) The input-output relationships are non-linear.

Example 26'15. A ballast circuit is to be used for a thermistor which has a nominal resistance of 100 Ω .

(a) What should be the value of the ballast resistor R_b , for maximum sensitivity at nominal transducer resistance ?

(b) If the ballast resistance as calculated in (a) is used along with an input of 10 V, what output voltage will be obtained when the transducer has resistance equal to its nominal resistance ?

(c) If the conditions of (b) remain, except the transducer resistance is reduced by 5 per cent, what output voltage will be indicated ?

(d) What are the sensitivities for (b) and (d) ?

Solution. (a) Nominal value of transducer resistance $R_t = 100 \Omega$.

At nominal resistance of transducer $K=1$.

For maximum sensitivity : ballast resistance $R_b = KR_t = 1 \times 100 = 100 \Omega$.

(b) From Eqn. 26'42, output voltage with $R_b = 100 \Omega$:

$$e_0 = \frac{K R_t / R_b}{1 + K R_t / R_b} e_i = \frac{1 \times 100 / 100}{1 + (1 \times 100 / 100)} \times 10 = 5 \text{ V.}$$

(c) If the resistance of the transducer decreases by 5%, we have $K=0.95$.

$$\therefore \text{Output voltage} = \frac{0.95 \times 100 / 100}{1 + (0.95 \times 100 / 100)} \times 10 = 4.87 \text{ V.}$$

(d) From Eqn. 26'43, sensitivity

$$S = \frac{e_i R_b}{(R_b + K R_t)^2}$$

For (b), $K=1$, and the sensitivity,
$$S = \frac{10 \times 100}{(100 + 1 \times 100)^2} = 0.025 \text{ V}/\Omega$$

For (d), $K=0.95$ and the sensitivity
$$S = \frac{10 \times 100}{(100 + 0.95 \times 100)^2} = 0.0263 \text{ V}/\Omega$$

Example 26.16. A simple ballast circuit is used to measure the output of a pressure pickup. The circuit is designed so that the internal resistance is six times the total transducer resistance. A source of 100 V is used to energize the circuit. Calculate the voltage output at 25, 50, 60 and 80 percent full load on the transducer.

Solution. Let the transducer resistance be R_t at full load. Therefore, the ballast resistance $R_b = 6 R_t$.

$$\text{Output voltage } e_o = \frac{K R_t / R_b}{1 + (K R_t / R_b)} e_i$$

Now $R_b = 6 R_t$, and $e_i = 100 \text{ V}$. $\therefore e_o = \frac{K \times 1/6}{1 + (1/6)K} \times 100 = \frac{16.7 K}{1 + 0.167 K}$

$$\therefore \text{Voltage output at 25 percent load} = \frac{16.7 \times 0.25}{1 + 0.167 \times 0.25} = 4 \text{ V}$$

Similarly voltage output at 50% load is 7.7 V, at 60% load 9.11 V and at 80% load 11.78 V.

26.17. Bridge Circuits

Bridge circuits of various types are used in instrumentation systems for the measurement of resistance, inductance and capacitance. The bridges may be either of the two types viz: (i) d.c. type, and (ii) a.c. type.

In case the output of resistive type of transducers is to be measured, either d.c. or a.c. bridges may be used. But when measuring inductance or capacitance which may be on account of output of inductive or capacitive transducers, a.c. bridges are used.

26.18. Wheatstone Bridge

It is the most commonly used d.c. bridge for measurement of resistance. This bridge is used for measurement of small resistance changes that occur in passive resistive transducers like strain gauges, thermistors and resistance thermometers. Detailed description of a Wheatstone bridge has already been given in chapter 16.

Fig. 26.62 shows the basic circuit of a Wheatstone bridge. It consists of four resistive arms with a source of emf (a battery) and a meter which acts as a detector. The detector is usually a current sensitive galvanometer. Measurements may be carried out either by balancing the bridge or by determining the magnitude of unbalance.

This means that there are two ways in which a Wheatstone bridge can be used. Thus there are two types of Wheatstone bridge. They are: (i) Null type bridge, and (ii) Deflection type bridge.

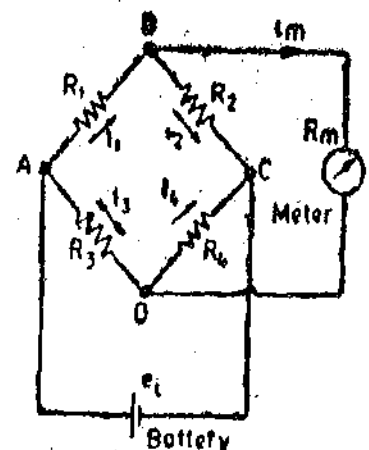

Fig. 26.62. Wheatstone bridge.

26.18.1. Null Type Bridge

When using this type of measurement, adjustments are made in various arms of the bridge so that the voltage across the detector is zero and hence no current flows through it. When no current flows through detector, the bridge is said to be **balanced**.

$$\text{Under balance conditions: } R_1 = R_2 (R_3 / R_4) \quad \dots(26.44)$$

Resistance R_1 represents the resistance of a resistive transducer whose value depends upon the physical variable being measured. The ratio of resistors R_3 and R_4 is fixed for a particular

measurement. The bridge is balanced by varying the value of resistor R_2 . Thus if three resistances are known the fourth may be determined from Eqn. 26'44.

In instrumentation work, it is the change ΔR_1 in the transducer resistance R_1 which is to be found. The change unbalances the bridge and therefore resistor R_2 has to be adjusted by an amount ΔR_2 to restore balance.

$$\begin{aligned} \text{The rebalanced conditions give : } R_1 + \Delta R_1 &= (R_2 + \Delta R_2)(R_3/R_4) = R_2(R_3/R_4) + \Delta R_2(R_3/R_4) \\ &= R_1 + \Delta R_2(R_3/R_4) \quad \therefore \Delta R_2 = \Delta R_1(R_4/R_3) \end{aligned} \quad \dots(26'45)$$

Some applications such as temperature measuring systems (where the resistance, R_1 of the transducer changes on account of temperature), an automatic bridge balancing control system may be used as shown in Fig. 26'63.

When there is change in resistance R_1 , it produces a voltage output which is amplified and applied as an error signal to the field winding of a d.c. motor. The motor is coupled to a moving contact. This movable contact is actuated so as to reduce the unbalance and hence the error voltage. When the bridge is balanced, there is no error voltage and therefore there is no voltage across the field winding of the motor. The motor stops and thus the slider comes to rest. The read out scale may be calibrated in resistance change values or in terms of temperature or any other physical variable being measured.

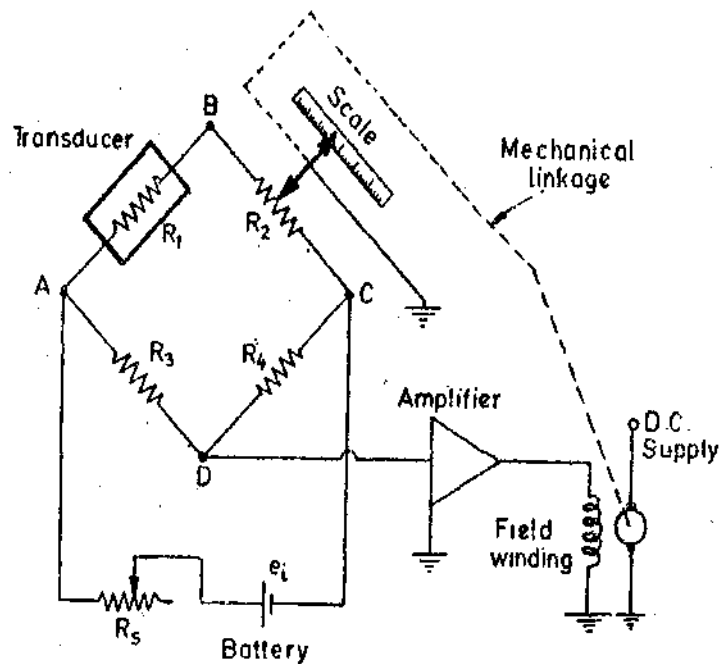

Fig. 26'63. Self (automatic) balancing Wheatstone bridge.

26'18 2. Deflection Type Bridge

The null type Wheatstone Bridge is accurate but the problem with this bridge is that the balancing, even if done automatically, is not instantaneous. Therefore this bridge is unsuitable for dynamic applications where the changes in resistance are rapid. For measurement of rapidly changing input signals, the **Deflection Type Bridge** is used. When the input changes, the resistance R_1 changes producing an unbalance causing a voltage to appear across the meter. The deflection of the meter is indicative of the value of resistance and the scale of the meter may be calibrated to read the value of resistance directly.

For static inputs, an ordinary galvanometer may be used. However for dynamic inputs, output signal may be displayed by a cathode ray oscilloscope or may be recorded by a recorder.

The deflection type bridge circuit is provided with a zero setting arrangement as shown in Fig. 26'64. The series resistance R_s is used to change the bridge sensitivity.

When a deflection type bridge is used, the bridge output on account of the unbalance may be connected either to a high input impedance device or to a low input impedance device. If the output of the bridge is connected directly to a low impedance devices like a current galvanometer or a PMMC instrument, a large current flows through the meter. In this case, the bridge is called a Current Sensitive Bridge.

In most of the applications of deflection type bridge, the bridge output is fed to an amplifier which has a high input impedance and therefore the output current $i_m=0$. This would also be the case if the bridge output is connected to a CRO or a V.T.V.M. or a digital voltmeter. The bridge thus used is a Voltage Sensitive Bridge.

26'18'3. Voltage Sensitive Bridge

For analysis of this bridge, we refer to Fig. 26'62. Let us assume that the input impedance of the meter is infinite and therefore $i_m=0$.

Hence $i_1=i_2$ and $i_3=i_4$, output voltage e_0 =voltage across terminals B and $D=i_1R_1-i_3R_3$.

But $i_1 = \frac{e_i}{R_1+R_2}$ and $i_3 = \frac{e_i}{R_3+R_4}$

$$\therefore e_0 = \left[\frac{R_1}{R_1+R_2} - \frac{R_3}{R_3+R_4} \right] e_i = \left[\frac{R_1R_4 - R_2R_3}{(R_1+R_2)(R_3+R_4)} \right] e_i \quad \dots (26\ 46)$$

Suppose now R_1 changes by an amount ΔR_1 . This causes a change Δe_0 in the output voltage. Thus :

$$e_0 + \Delta e_0 = \left[\frac{(R_1 + \Delta R_1)R_4 - R_2R_3}{(R_1 + \Delta R_1 + R_2)(R_3 + R_4)} \right] e_i$$

$$= \left[\frac{1 + (\Delta R_1/R_1) - (R_2R_3/R_1R_4)}{\{1 + (\Delta R_1/R_1) + (R_2/R_1)\}\{1 + (R_3/R_4)\}} \right] e_i \quad \dots (26\ 47)$$

In order to simplify the relationship, let us assume that initially all the resistances comprising the bridge are equal i.e., $R_1=R_2=R_3=R_4=R$.

Under these conditions : $e_0=0$, and $\Delta e_0 = \left[\frac{(\Delta R_1/R)}{4 + 2(\Delta R_1/R)} \right] e_i \quad \dots (26\ 48)$

It is clear from Eqn. 26'48 that the input-output relationship i.e., relationship between ΔR and Δe_0 is non-linear. However, if the change in resistance is very small as compared to initial resistance, then we have : $2(\Delta R_1/R) \ll 4$.

$$\therefore \Delta e_0 = \frac{(\Delta R_1/R)}{4} e_i \quad \dots (26\ 49)$$

$$\Delta e_0 = \frac{1}{4} \Delta R_1 \frac{e_i}{R} \quad \dots (26\ 50)$$

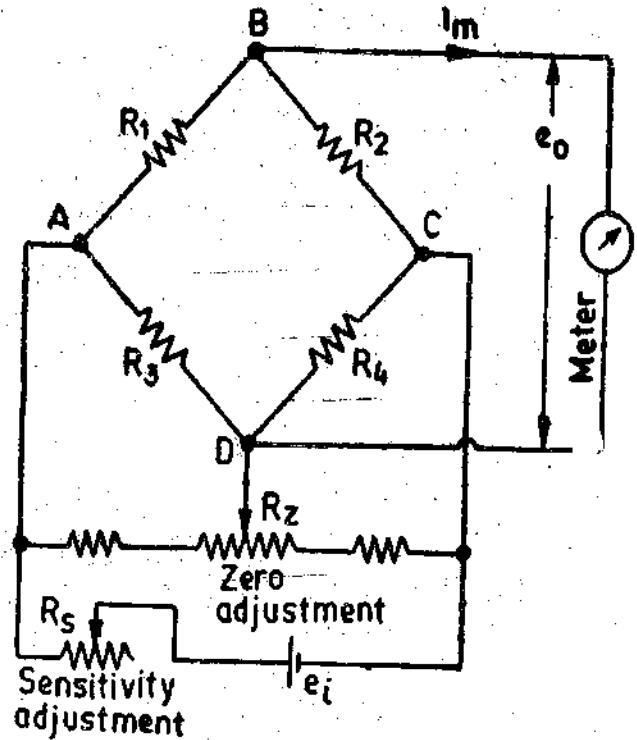

Fig. 26'64. Deflection Type Wheatstone Bridge provided with zero adjustment and sensitivity adjustment arrangements.

∴ For such cases, the input-out relationship is linear. The major disadvantage of a voltage sensitive deflection bridge as compared to voltage sensitive null bridge is that the calibration of the former is dependent upon the value of supply voltage e_s as is evident from Eqns. 26'49 and 26'50. Therefore for constancy of calibration, the input voltage should be absolutely constant.

26'18 4. Current sensitive bridge. When using galvanometers at the output terminals, the resistance of the meter cannot be neglected as galvanometers draw an appreciable current. Under such circumstances, wherein the measuring device has a low impedance, the deflection is on account of the meter current i_m , which cannot be assumed to be zero, the bridge is said to be a **current sensitive bridge**.

In order to find the input-output relationship and the bridge sensitivity for this general case, it is necessary to convert the bridge circuit of Fig. 26'62, to a Thevenin generator looking into the output terminals B and D .

Open circuit voltage of the Thevenin generator
$$e_0 = \frac{R_1 R_4 - R_2 R_3}{(R_1 + R_2)(R_3 + R_4)} e_s$$

The internal resistance of the Thevenin generator is found from looking into terminals B and D and shorting terminals A and C as shown in Fig. 26'65 (a). The internal resistance of the Thevenin generator looking into the terminals B and D and is :

$$R_0 = \frac{R_1 R_2}{R_1 + R_2} + \frac{R_3 R_4}{R_3 + R_4} = \frac{(R_1 R_2)(R_3 + R_4) + R_3 R_4 (R_1 + R_2)}{(R_1 + R_2)(R_3 + R_4)} \quad \dots(26'51)$$

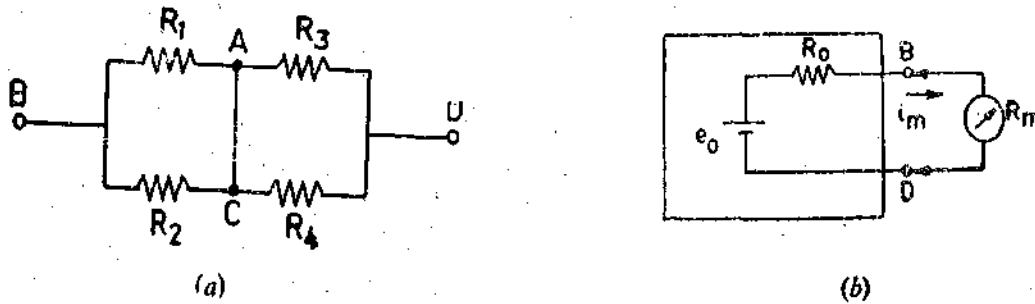

Fig. 26'65. Thevenin Equivalent of Bridge Circuit.

The equivalent Thevenin generator is shown in Fig. 26'65 (b).

The current through the meter is given by :

$$i_m = \frac{e_0}{R_0 + R_m} = \frac{[R_1 R_4 + R_2 R_3] e_s}{R_1 R_2 (R_3 + R_4) + R_3 R_4 (R_1 + R_2) + R_m (R_1 + R_2)(R_3 + R_4)} \quad \dots(26'52)$$

Suppose initially, all the resistances are equal i.e. $R_1 = R_2 = R_3 = R_4 = R$.

Let there be a change ΔR in R_1 ,

$$\begin{aligned} \therefore \text{Meter Current, } i_m &= \frac{[(R + \Delta R)R - R^2] e_s}{(R + \Delta R)R(2R) + R^2(R + \Delta R + R) + R_m(\Delta R + R + R)(2R)} \\ &= \frac{[(\Delta R/R^2) e_s]}{2(1 + \Delta R/R) + (2 + \Delta R/R)[1/R + (2R_m/R)(\Delta R/R)]} \quad \dots(26'53) \end{aligned}$$

when $R \gg \Delta R$ we have,
$$i_m = \frac{(\Delta R/R^2) e_s}{4(1 + R_m/R)} \quad \dots(26'54)$$

Voltage output under load conditions is :

$$e_{OL} = i_m R_m = \left[\frac{(\Delta R/R^2) e_s}{1 + R_m/R} \right] \frac{R_m}{4} = \frac{(\Delta R/R) R_m e_s}{4(R + R_m)} = \frac{\Delta R/R}{4(1 + R/R_m)} e_s \quad \dots(26'55)$$

From Eqn. 26'55, it follows that open circuit voltage
$$e_0 = \frac{\Delta R}{4R} e_s \quad \dots(26'56)$$

The voltage under loaded conditions is : $e_{0L} = \frac{e_0 R_m}{R_0 + R_m}$

$$\therefore \text{Ratio of voltage under loaded and no load } \frac{e_{0L}}{e_0} = \frac{1}{1 + R_0/R_m} \quad \dots(26.57)$$

Example 26.17. A resistance bridge has the configuration shown in Fig. 26.62, in which $R_1 = 120.4 \Omega$, $R_2 = 119.7 \Omega$ and $R_3 = 119.7 \Omega$. (a) What resistance must R_4 have for resistance balance? (b) If R_4 has a value of 121.2Ω , and if the input voltage is 12 V d.c. , what will be the reading of meter, assuming it to be voltage sensitive bridge?

Solution.

(a) Value of R_4 for balance $= (R_3 \times R_2 / R_1) = 119 \times (119.7 / 120.4) = 118.3 \Omega$.

(b) From Eqn. 26.46, the output voltage is :

$$e_0 = \left[\frac{R_1 R_4 - R_2 R_3}{(R_1 + R_2)(R_3 + R_4)} \right] e_i = \left[\frac{120.4 \times 121.2 - 119.7 \times 119}{(120.4 + 119.7)(119 + 121.2)} \right] \times 12$$

$$= 0.0724 \text{ V} = 72.4 \text{ mV.}$$

Example 26.18. A simple equal arm voltage sensitive bridge is initially in balance (null). Three of the arms consist of ordinary resistors, while the fourth is a thermistor. Each arm has a nominal resistance of $10,000 \Omega$, and the bridge is energised with a 6 V d.c. source. (a) If the temperature change causes a $+5\%$ change in thermistor resistance, what output voltage will be indicated from the bridge? (b) If a -5% change in resistance is caused, what will be the bridge output?

Solution.

(a) Let the thermistor form resistance R_1 of bridge circuit shown in Fig. 26.62.

Initially $R_1 = R_2 = R_3 = R_4 = R = 10,000$

Change in resistance $\Delta R/R = +5\% = +0.05$.

$$\text{Output voltage of equal arm bridge } e_0 = \left[\frac{(\Delta R/R)}{4 + 2(\Delta R/R)} \right] e_i \quad (\text{see Eqn. 26.48})$$

$$= \left[\frac{0.05}{4 + 3 \times 0.05} \right] \times 6 = 0.0732 \text{ V} = 73.2 \text{ mV.}$$

(b) Change in resistance $\Delta R/R = -5\% = -0.05$.

$$\therefore \text{Output voltage } e_0 = \left[\frac{-0.05}{4 - 2 \times 0.05} \right] \times 6 = -0.077 = -77 \text{ mV.}$$

Example 26.19. It is known that a certain transducer has a resistance of approximately 800Ω . This transducer is connected as resistor R_1 in the Wheatstone bridge shown in Fig. 26.62. The other three arms of the bridge have resistances of exactly 800Ω . A 4 V battery with negligible internal resistance is used in the circuit. The galvanometer resistance is 100Ω and the galvanometer current is $0.8 \mu\text{A}$. Calculate the resistance of the unknown resistor.

Solution.

The resistances are : $R_2 = R_3 = R_4 = 800 \Omega$ and meter resistance $R_m = 100 \Omega$.

Galvanometer current $i_m = 0.8 \mu\text{A} = 0.8 \times 10^{-6} \text{ A}$. Battery voltage $e_i = 4 \text{ V}$.

Using the approximate formula given in Eqn. 26.54, we have : $i_m = \frac{(\Delta R/R^2)e_i}{4(1 + R_m/R)}$

$$\text{or } 0.8 \times 10^{-6} = \frac{\Delta R \times 4}{(800)^2 [4 + (100/800)]} \quad \text{or } \Delta R = 0.528 \Omega$$

$$\therefore R_1 = R + \Delta R = 800 + 0.528 = 800.528 \Omega.$$

Example 26.20. In a Wheatstone bridge three out of four resistors have a value of $1\text{ k}\Omega$ each, and the fourth resistor equals $1010\ \Omega$. If the battery voltage is 100 V , what is the approximate value of the open circuit voltage? If the output of the bridge is connected to a $4\text{ k}\Omega$ resistor how much current would flow through the resistor?

Solution.

This problem can conveniently be solved by Thevenin theorem.

$$\text{Open circuit voltage } e_0 = \left(\frac{1010}{1010+1000} - \frac{1000}{1000+1000} \right) \times 100 = 0.249\text{ V}$$

Internal resistance of the bridge looking into its output terminals,

$$R_0 = \frac{1010 \times 1000}{1010+1000} + \frac{1000 \times 1000}{1000+1000} = 1002.5\ \Omega$$

$$\text{Meter current } I_m = \frac{e_0}{R_0 + R_m} = \frac{0.249}{1002.5 + 4000} = 50\ \mu\text{A}$$

Example 26.21. A Wheatstone bridge is used for measuring the value of change of resistance of a strain gauge. All the arms of the bridge including the strain gauge have a resistance of $100\ \Omega$. The maximum allowable power dissipation from the strain gauge is 250 mW . Find out the value of maximum permissible current through strain gauge and the maximum allowable value of bridge supply voltage. Suppose a source of 20 V is available, find the value of the series resistance R_s to limit the input voltage of the bridge to the permissible level. What is the power dissipation in the series resistor?

Solution.

Suppose e_i is the input voltage. The value of resistance of each arm is $R = 100\ \Omega$.

Maximum power dissipation from the strain gauge $P = 250\text{ mW} = 250 \times 10^{-3}\text{ W}$.

Now $P = i^2 R$ where $i =$ maximum permissible current.

$$i = \sqrt{P/R} = \sqrt{250 \times 10^{-3}/100} = 0.05\text{ A} = 50\text{ mA}$$

Maximum value of input voltage for the bridge $e_i = 2iR = 2 \times 50 \times 10^{-3} \times 100 = 10\text{ V}$.

The supply voltage is 20 V and the maximum allowable voltage is 10 V . Therefore a series resistance R_s has to be inserted to reduce the voltage to 10 V .

Since all the arms of the bridge have equal resistance value of $100\ \Omega$ each, the resistance of the bridge looking into output terminals is $R = 100\ \Omega$. As the bridge and the series resistance have equal voltage drops (10 V) across them, the value of series resistance R_s is also $100\ \Omega$.

$$\therefore \text{Power dissipation in series resistance} = \frac{(10)^2}{100} = 1\text{ W}$$

Example 26.22. A thermistor of resistance $1\text{ k}\Omega$, temperature co-efficient of resistance 4.5 per cent/ $^\circ\text{C}$ and an internal temperature rise of $0.2^\circ\text{C}/\text{mW}$ around 27°C is included in a d.c. bridge with three fixed resistors each of value of $1\text{ k}\Omega$. A d.c. amplifier of high input impedance is connected across the bridge output and an indicating device connected to the amplifier output.

(a) Calculate the maximum voltage sensitivity of the bridge if the internal temperature rise is not to exceed 0.1°C .

(b) Calculate the maximum amplifier drift, referred to the input that can be tolerated if the overall system accuracy is to be within $\pm 2^\circ\text{C}$.

Solution.

Power dissipation in the thermistor due to a change 0.1°C , $P = 0.1/0.2 = 0.5\text{ mW}$.

Supposing e_{im} is the maximum allowable input voltage across the bridge. Now each arm of the bridge has a resistance $R = 1\text{ k}\Omega$.

∴ Voltage across each arm = $e_{im}/2$

Power dissipation in thermistor $P = \left(\frac{e_{im}}{2} \right)^2 \times \frac{1}{R}$

∴ Maximum allowable input voltage $e_{im} = 2\sqrt{PR} = 2\sqrt{0.5 \times 10^{-3} \times 10^3} = 1.41 \text{ V}$.

Change in resistance of thermistor $\Delta R_1 = \alpha \Delta \theta R = \frac{4.5}{100} \times 0.1 \times 1000 = 4.5 \Omega$

Bridge output voltage, when all the arms have equal initial resistance = $\Delta e_0 = \frac{\Delta R_1/R}{4} e_i$

∴ Maximum output voltage $e_{om} = \frac{4.5/1000}{4} \times 1.41 = 1.59 \times 10^{-3} \text{ V} = 1.59 \text{ mV}$.

This voltage change is caused by temperature input of 0.1°C .

∴ Maximum bridge sensitivity $S = \frac{\Delta e_0}{\Delta \theta} = \frac{1.59}{0.1} = 15.9 \text{ mV}/^\circ\text{C}$.

26.19. A.C. Bridges. Alternating current bridge methods are of outstanding importance in electrical measurements. The theory of a.c. bridges has been explained in chapter 22. A.C. bridges are widely used for variable inductance and capacitance bridges. This section deals with special a.c. bridges used for instrumentation purposes.

26.19.1. A.C. Bridges using Push-Pull Transducers. The a.c. bridges are suited for accepting inputs from push-pull transducers, *i.e.*, transducers which accept input from transducers working on differential principle. When a transducer works on a push-pull principle, it produces a more linear relationship with the bridge output and the measured quantity than is produced by a single element transducer. Another advantage of the push-pull transducers is that when they are connected in the adjacent arms of a bridge, any equal changes such as due to temperature in the two parts of the transducer act against each other and hence are cancelled out.

26.19.2. A.C. Bridges with Push-Pull Inductive Transducers. A push-pull inductance transducer consists of two parts each having an initial inductance value L . If an input signal is applied to this transducer the inductance of one part increases by ΔL while that of other part reduces by ΔL . Thus the inductance of one part becomes $L + \Delta L$ while that of other $L - \Delta L$.

Fig. 26.66 (a) shows an arrangement of connecting an inductive push-pull transducer in an a.c.

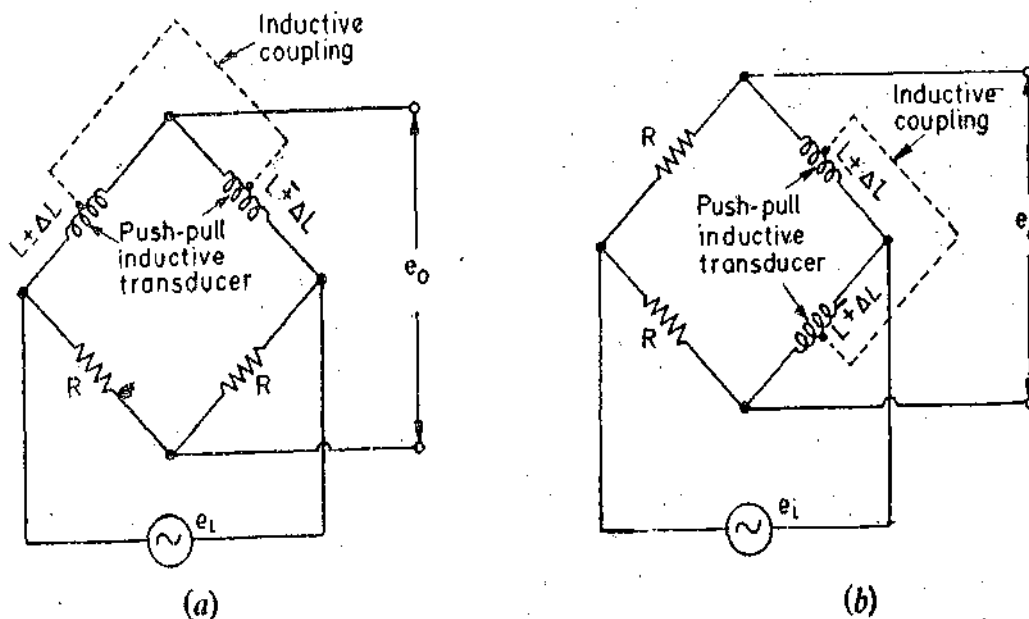

Fig. 26.66. Push-pull inductive transducers connected in a.c. bridges.

bridge. The bridge is initially balanced but when a change occurs in the inductance of the transducer on account of application of an input signal, it becomes unbalanced. For transducers using high Q coils have $\omega L \gg R$ and therefore the changes in resistance of transducer coils is insignificant in comparison with change of inductance. Hence,

$$\text{Output voltage } e_0 = \frac{1}{2} \frac{\Delta L}{L} e_i \quad \dots(26'58)$$

Another arrangement is shown in Fig. 26'66 (b). In case the Q factor is unity i.e. $\omega L = R$.

$$\text{Output voltage } e_0 = (\Delta L/L) e_i \quad \dots(26'59)$$

Hence, the sensitivity of this bridge is twice that of the one shown in Fig. 26'67 (a).

26'19'3. Inductive Transducer Blumlein Bridge. Blumlein bridge, as shown in Fig. 26'67 (a) uses two closely coupled inductive ratio arms and other two arms consist of one part each of a push-pull inductive transducer of a high Q value. The equivalent T network of the closely coupled arms is shown in Fig. 26'67 (b).

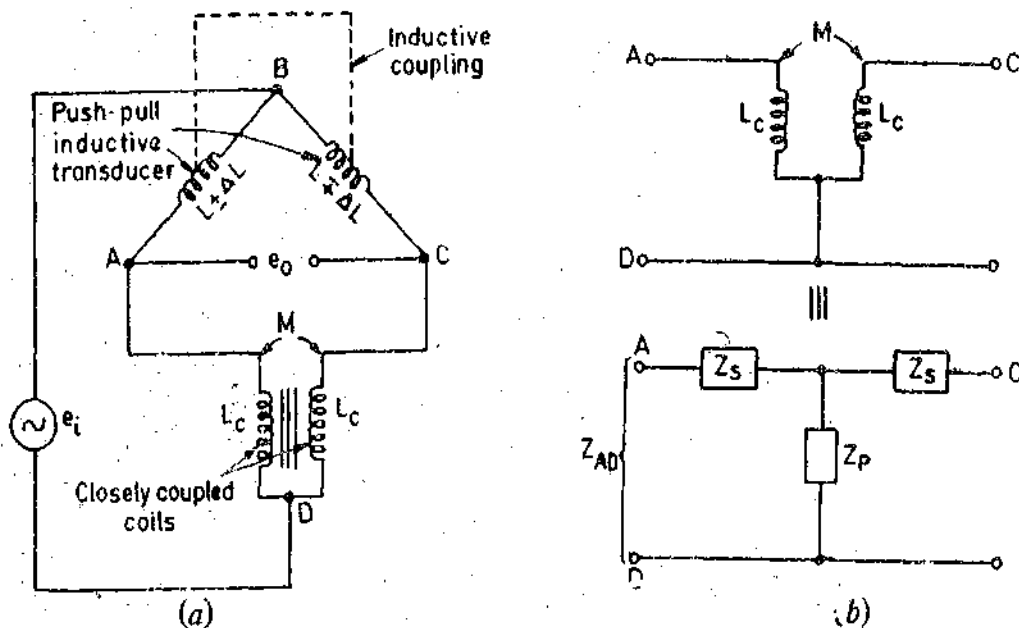

Fig. 26'67. Inductive transducer Blumlein bridge.

For networks to be equivalent, $Z_{AD} = Z_s + Z_p = j\omega M$

The coupling factor between the closely coupled coils is $K = \pm M/L_c$ and for perfect coupling $K = \pm 1$.

At the bridge balance, the currents in the two coils are equal and are in the same direction and for a particular winding sense and therefore $K = +1$.

Therefore under balance conditions, impedance across ratio arms is :

$$2Z_s = 2j\omega(L_c - M) \quad \text{and} \quad \text{with } K=1 \text{ we get } 2Z_s = 0.$$

Thus it is evident that there is no voltage drop across the ratio arms and any stray or cable capacitance which is in parallel with the ratio arms becomes ineffective. Thus shielding and earthing problems are greatly simplified. This is the biggest advantage of Blumlein bridge.

When the bridge is not balanced, the change in the currents on the two sides of the bridge can be considered as a circulating current around the bridge. Thus for this condition the coupling factor K changes sign and is $K = -1$ and therefore $2Z_s = 4j\omega L_c$.

In order to find the sensitivity of the bridge, the parallel impedance of T network Z_p ($= -j\omega L_c$) may be considered to be connected in series with bridge impedance Z_s with bridge supply voltage across them.

$$\text{Bridge impedance } Z_B = \frac{j\omega L(1+2L_c/L + \Delta L/L)(1+2L_c/L - \Delta L/L)}{2(1+2L_c/L)} \quad \dots(26'60)$$

Neglecting Z_F , the open circuit output voltage

$$e_0' = \frac{\Delta L}{L} \cdot \frac{4L_c/L}{(1+2L_c/L + \Delta L/L)(1+2L_c/L - \Delta L/L)} e_i \quad \dots(26'61)$$

with Z_F in series with Z_B , we have, open circuit voltage

$$e_0 = \frac{Z_B}{Z_B + Z_F} e_0' = \frac{\Delta L}{L} \cdot \frac{4L_c/L}{(1+2L_c/L)} e_i \quad \dots(26'62)$$

Eqn. 26'62 is based upon the assumption that $(\Delta L/L)^2 \ll 1$.

$$\text{Bridge sensitivity factor} = \frac{e_0}{e_i(\Delta L/L)} = \frac{4L_c/L}{(1+2L_c/L)} \quad \dots(26'63)$$

Fig. 26'68 shows the variation of bridge sensitivity factor with variation in ratio L_c/L for a bridge with tightly coupled ratio arms ($K=-1$) and with uncoupled ratio arms ($K=0$). In both the cases the bridge sensitivity is independent of frequency. It is observed from Fig. 26'68, that the bridge with tightly coupled ratio has a higher sensitivity throughout and when $L_c \gg L$, the sensitivity factor is 2 and is essentially independent of ratio arm inductance variations.

26'19'4. Capacitive Transducer Blumlein Bridge. A Blumlein bridge using push-pull capacitive transducers is shown in Fig. 26'69 (a). Analyzing this bridge in the same way as was done for inductive Blumlein bridge, it can be shown that output voltage is

$$e_0 = \frac{\Delta C}{C} \cdot \frac{4\omega^2 L_c C}{(2\omega^2 L_c C - 1)} e_i \quad \dots(26'64)$$

$$\therefore \text{Bridge sensitivity factor} = \frac{e_0}{e_i(\Delta C/C)} = \frac{4\omega^2 L_c C}{(2\omega^2 L_c C - 1)} \quad \dots(26'65)$$

The variation of bridge sensitivity factor with $\omega^2 L_c C$ is shown in Fig. 26'69 (b). Resonance

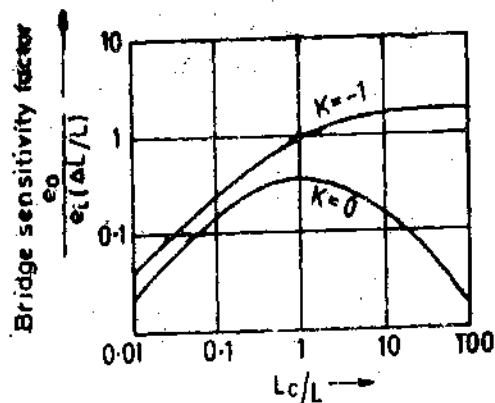
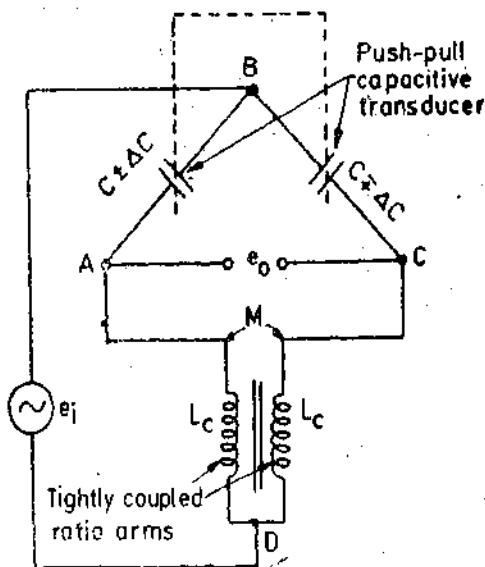
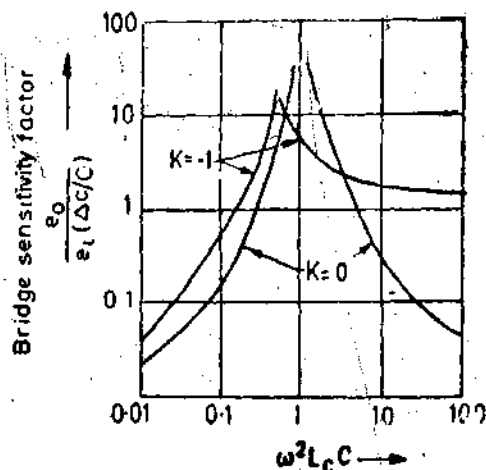

Fig. 26'68. Variation of bridge sensitivity with L_c/L .



(a) Bridge.



(b) Variation of bridge sensitivity factor with $\omega^2 L_c C$

Fig. 26'69. Capacitive transducer Blumlein bridge.

occurs when $2\omega^2 L_c C = 1$, and above resonance, when $\omega^2 L_c C \gg 1$, the sensitivity factor is 2 and is independent of the variations in bridge frequency and ratio arm inductance.

The variation of sensitivity factor for an uncoupled bridge is also shown. It is noted that the uncoupled arm bridge has no horizontal characteristics and there is no region where sensitivity is independent of frequency or inductance.

Thus the advantages of a capacitive transducer bridge with tightly coupled arms are :

- (i) there are no noise and pickup problems,
- (ii) the bridge is insensitive to variations in frequency and inductance provided $\omega^2 L_c C \gg 1$,
- (iii) the sensitivity is practically constant and is higher than that of bridge with uncoupled arms.

Example 26.23. A push-pull capacitive transducer is used in a Blumlein bridge as shown in Fig. 26.20 (a). The frequency of bridge supply is 1 MHz. At balance, the capacitance of each half of the transducer is 500 pF. (a) Determine suitable values of inductance for the tightly coupled ratio arms to make the bridge sensitivity essentially independent of variations in inductance and bridge supply frequency, (b) output impedance of bridge under balanced and unbalanced conditions.

Solution. (a) The sensitivity is independent of the variations in inductance and frequency if $\omega^2 L_c C \gg 1$.

$$\text{Let } \omega^2 L_c C = 10 \therefore \text{Inductance } L_c = \frac{10}{\omega^2 C} = \frac{10}{(2\pi \times 10^6)^2 \times 500 \times 10^{-12}} \text{ H} = 0.506 \text{ mH.}$$

(b) Output impedance of bridge under balance conditions is zero output impedance of bridge under unbalanced conditions consists of impedances $4j\omega L_c$ and $2/(j\omega C)$ in parallel. However $4\omega L_c$ is very large as compared with $2/\omega C$ and hence the output impedance is approximately equal to $2/\omega C$

$$\text{Output impedance} = \frac{2}{2 \times 1 \times 10^6 \times 500 \times 10^{-12}} = 2000 \Omega = 2 \text{ k}\Omega.$$

26.20. Integration and Differentiation. In many measurement systems it becomes necessary to obtain integrals and/or derivatives of signals with respect to time. It is easy to integrate a signal as integration leads to attenuation of noise at the output terminals and hence improves the signal to noise (S/N) ratio. However, accurate differentiation is much harder to carry out since differentiation increases the signal to noise ratio. The integration and differentiation processes may be carried out by RC networks in addition operational amplifiers which have been described earlier.

26.20.1. Low pass RC Filter as an Integrator. A low pass RC filter shown in Fig. 26.46 is used as an integrator.

Transfer function of the circuit is:
$$\frac{E_o(s)}{E_i(s)} = \frac{1}{1 + \tau s}$$

Sinusoidal transfer function
$$\frac{e_o}{e_i}(j\omega) = \frac{1}{1 + j\omega\tau}$$

Now, If $\omega\tau \gg 1$, we have:
$$\frac{e_o}{e_i}(j\omega) \approx \frac{1}{j\omega\tau} \quad \text{or} \quad \frac{E_o(s)}{E_i(s)} = \frac{1}{s\tau}$$

Taking inverse Laplace transform
$$e_o = \frac{1}{\tau} \int e_i dt.$$

This means that when $\omega\tau \gg 1$, the RC circuit acts a pure integrator.

26.20.2. High Pass RC Filters as Differentiators. Fig. 26.49 shows a circuit for a high pass RC filter.

The transfer function for this circuit is:
$$\frac{E_o(s)}{E_i(s)} = \frac{1}{1 + 1/\tau s}$$

Sinusoidal transfer function $\frac{e_0}{e_i}(j\omega) = \frac{1}{1 + 1/j\omega\tau}$

In case $\omega\tau \ll 1$, we have $\frac{e_0}{e_i}(j\omega) = j\omega\tau \quad \therefore \frac{E_0(s)}{E_i(s)} = s\tau$

Taking inverse Laplace transform $e_0 = \tau \frac{de_i}{dt}$

Thus if $\omega\tau \ll 1$, the circuit becomes a differentiator.

Example 26.24. A triangular input voltage of peak value 20 V is applied to a high pass filter having $C = 1 \mu\text{F}$ and $R = 1 \text{ k}\Omega$. The time period of the wave is 400 ms, find the output d.c. voltage.

Solution.

The wave rises to its peak value in $1/4$ of a cycle : $\therefore t = \frac{400}{4} \text{ ms} = 100 \text{ ms}$.

Charging current $i = C \frac{dv}{dt} = 1 \times 10^{-6} \times \frac{20}{100 \times 10^{-3}} = 0.2 \times 10^{-3} \text{ A}$.

The output voltage is a square wave of amplitude : $e_0 = iR = 0.2 \times 10^{-3} \times 1 \times 10^3 = 0.2 \text{ V}$.

26.21. Analog/Digital/Analog Conversion Techniques

The most naturally occurring phenomena are analog in nature. Analog quantities are continuous functions with time and most transducers give an analog output.

With the introduction of digital computer, the data taken in a physical system has to be converted into a digital form. When system engineers made their first attempts at applying computational power, speed and data handling capability of digital computers to automatic control systems, they were faced with a tremendous task of making the digital computer to work with analog devices.

The data to be fed to digital devices, normally appears in analog form. For example, a temperature difference would be represented by the voltage output of a thermocouple, the strain of a mechanical member would be represented the voltage resulting from an unbalanced strain gauge resistance bridge. Therefore the need arises for a device that converts analog information into digital form. Therefore, **analog to digital A/D conversion devices** are used in measurement and instrumentation systems.

It should be borne in mind that digital quantities are discrete and vary in equal steps. Each digital number is a fixed sum of equal steps which is defined in that number.

26.21.1. Resolution and quantization. In A/D converters the original analog signal has essentially an infinite resolution as the signal is continuous. The digital representation of this signal would of course reduce, this resolution as digital quantities are discrete and vary in equal steps. Each digital number is a fixed sum of equal steps which is defined by that number.

In order to convert an analog quantity to a digital number involves **quantization**. The characteristics of a Quantizer are shown in Fig. 26.70.

This quantizer is used for conversion of analog voltages of 0–7 V. Now in binary code, decimal number 7 = binary 111. Therefore the digital number has 3 bits.

The analogue input is shown in Fig. 26.70 (a) on the horizontal axis and the discrete output voltage level on the vertical axis. The basic operation of A/D conversion involves two processes, viz., (i) quantization and (ii) coding.

The decision levels of the A/D convertor are at 0.5, 1.5, 2.5, 3.5, etc. Thus the design levels are spaced 1 V apart. Analog values between two decision levels cannot be coded. In fact, analog values between 1 ± 0.5 are read as digital value 001. The distance between decision levels is Q , the quantization size. An n bit A/D converter has 2^n discrete levels with resolution = $1/2^n$ or 1 part in 2^n and analog decision levels = $2^n - 1$.

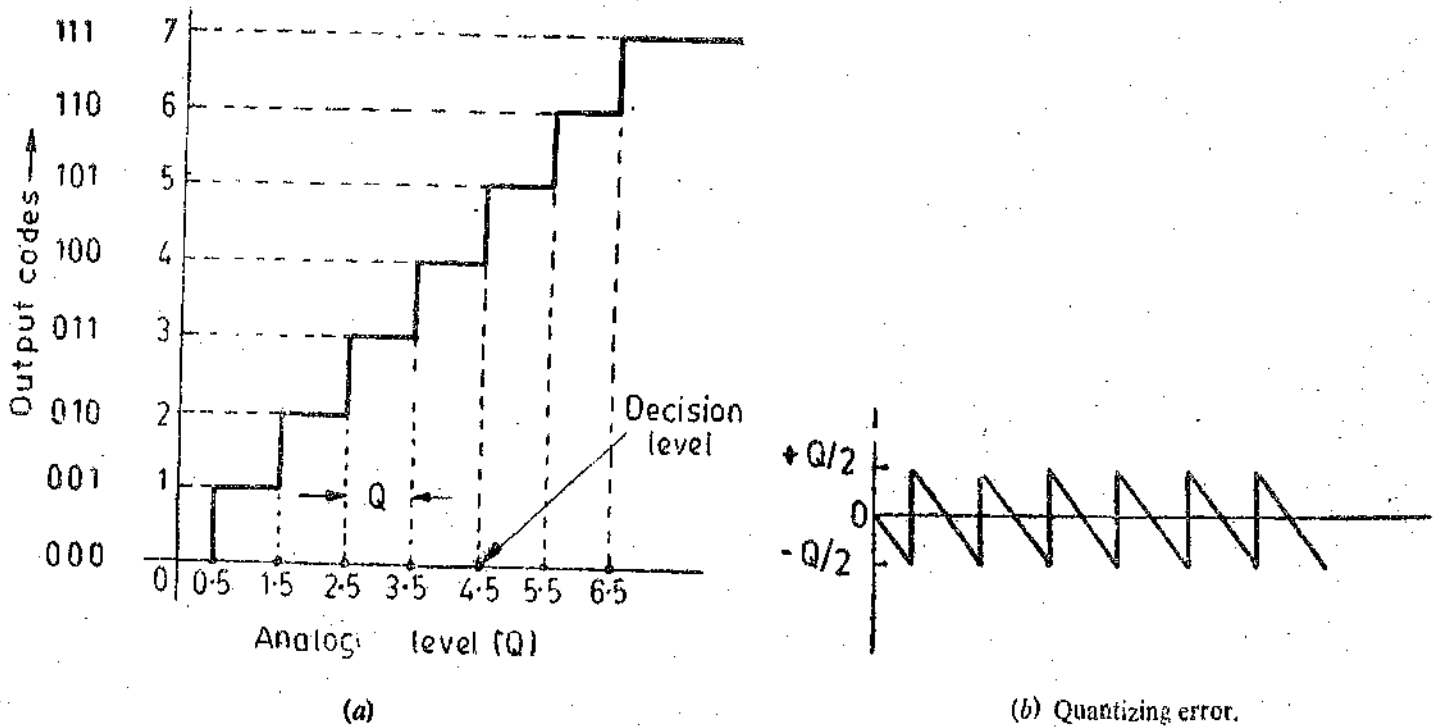

Fig. 26.70. Characteristics of a Quantizer

If the input to the quantizer is moved through its full range and subtracted from the discrete output levels, the error signal is shown in Fig. 26.70 (b). This is called quantization error. The quantization error is dependent on the number of quantization levels. The quantization levels are an index of the resolution of the instrument. The quantization error is of a sawtooth waveform as shown in Fig. 26.70 (b). The peak to peak value is Q . The output of a quantizer can be considered as a noise signal with an rms value of :

$$E_q = \frac{Q}{2\sqrt{3}} \quad \dots(26.66)$$

26.21.2. Aperture Time. In order to perform the operation of quantizing and coding a signal, an A/D converter requires an aperture time. A sample-and-hold (S/H) system is used in order to avoid the use of very fast and expensive A/D converters. The use of a sample-and-hold circuit is useful because it provides a very small time for taking a very rapid sample of the signal and then holding its value till it is converted. For a sinusoidal signal to be converted into a digital form, the maximum rate of change occurs at the instant where the voltage goes through zero. The amplitude change of voltage at this instant is :

$$\Delta E = \left[\frac{d}{dt}(E_m \sin \omega t) \right]_{t=0} \times t_a = E_m \omega t_a$$

$$\therefore \text{Aperture time } t_a = \frac{\Delta E}{\omega E_m} = \frac{\Delta E}{2\pi f E_m} \quad \dots(26.67)$$

26.21.3. Sampling In digital circuits, the data is sampled for a particular interval of time since the communication channels are many a time shared by a number of variables. The main purpose of signal sampling is the efficient use of the data processing and the data transmission units. The sampling operation is shown in Fig. 26.71. This shows that an analog signal and a train of periodic sampling signal whose 'on' time is extremely short as compared with the total period of the signal.

The result of the sampling process is identical to multiplying the analog signal by a train of pulses of unit magnitude. The resultant modulated signal is shown in Fig. 26.71 (c). This preserves the amplitude of the analog signal in the modulation envelope of the pulses.

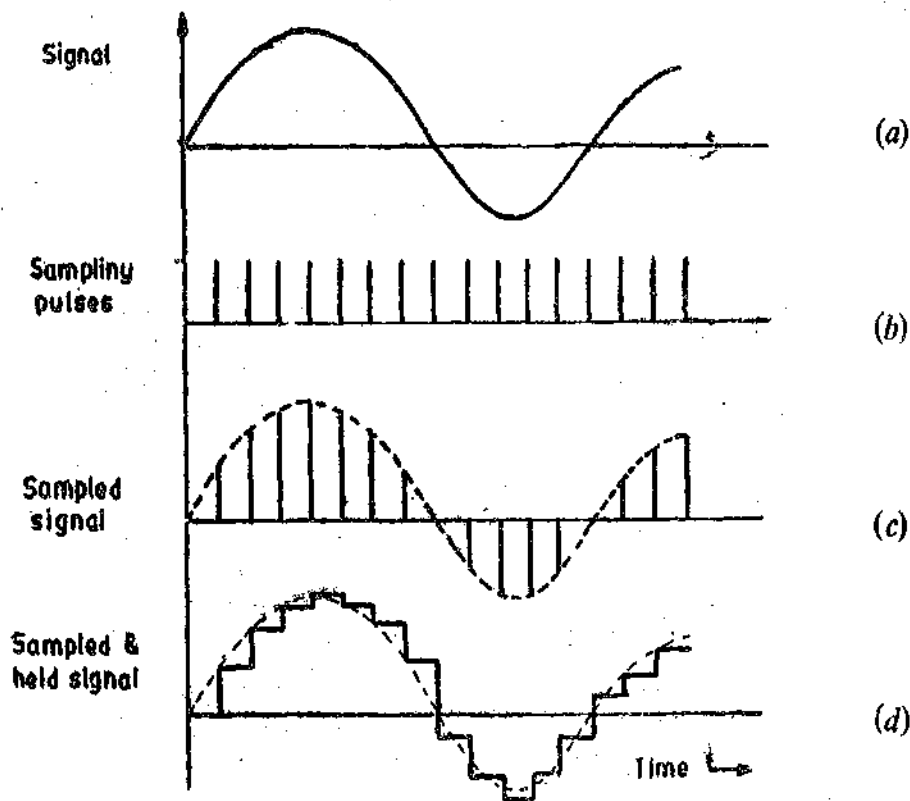

Fig. 26.71. Signal Sampling Process.

Now the question is how long a signal be sampled so as not to lose its identity. The sampling theorem states that if the highest frequency content in the input signal is f_h Hz, then input signal can be recovered without distortion if it is sampled at a rate of at least $2f_h$ samples per second. This is called the Nyquist rate. However, in practice it is necessary to sample at least $5f_h$ samples per second in order to reduce the effects of noise and non-sinusoidal filters. The sample and hold circuit acts as a low pass filter with a cut off frequency $f_o = f_s/2$ where $f_s =$ sampling frequency.

Example 26.25. (a) An analog transducer with a 0–10 V input is able to distinguish a change of 10 mV in its input signal. Calculate its resolution. (b) Calculate the number of bits of an A/D converter so that the digital output has almost the same resolution as the transducer. The A/D converter uses a binary code. Calculate also (c) the quantization error, and (d) the number of decision levels. Comment upon the results.

Solution.

$$(a) \text{ Resolution of analog instruments} = \frac{10 \text{ mV}}{10 \text{ V}} = \frac{10 \times 10^{-3}}{10} = \frac{1}{1000} = 1 \text{ part in } 1000.$$

(b) Let the A/D converter have n bits to give a resolution of 1 part in 1000.

$$\therefore \frac{1}{2^n} = \frac{1}{1000} \quad \text{or number of bits } n = 10$$

as $2^{10} = 1024$. (Nearly equal to 1000).

$$(c) \text{ Quantization interval } Q = \frac{10}{2^n} = \frac{10}{1024} \text{ V} \approx 1 \text{ mV.}$$

$$\text{Quantization error or noise } E_q = \frac{Q}{2\sqrt{3}} = \frac{1 \times 10^{-3}}{2 \times \sqrt{3}} = 0.29 \times 10^{-3} \text{ V} = 0.29 \text{ mV.}$$

$$(d) \text{ The number of decision levels} = 2^n - 1 = 1024 - 1 = 1023.$$

Comments : A resolution of 10 bits means that a 10 V signal can be resolved down to $(10/1024)$ V, or approximately 0.01 (1 mV) per bit. As the analog signal starts increasing from zero volt, the A/D converter will not have an output value until the analog signal equals or exceeds 0.01 V. After the A/D converter recognises this minimum signal and produces the correct output, that output will not change again until the output analog signal reaches a value of 0.02 V. Therefore, this 10 bit A/D converter with an analog input of 10 V cannot resolve, or recognize, changes less than 0.01 V (1 mV) in magnitude. It is therefore said to quantize the input, or chop it into chunks (quanta) of 0.01 V (1 mV) in size. Each 0.01 V (1 mV) chunk is considered to be a dead band.

26.22. General Considerations of A/D and D/A Conversion

A/D and D/A converters relate analog quantities to digital quantities and vice versa through an appropriate code. As mentioned earlier, the most commonly used code is the binary code, in which a number is represented by :

$$N = d_n \times 2^n + d_{n-1} \times 2^{n-1} + \dots + d_2 \times 2^2 + d_1 \times 2^1 + d_0 \times 2^0 \quad (\text{See Appendix A})$$

where the co-efficients $d_n, d_{n-1}, \dots, d_2, d_1, d_0$ assume the values of either 0 or 1. The leftmost bit is $d_n 2^n$ (d_n may be 1 or 0). This is called the Most significant bit (MSB) and that it has a weight (maximum value) which is twice as large as the next most significant bit (next bit between MSB and binary point). This is evident as 2^n has twice large a weight as 2^{n-1} . Each binary bit has a weight which is twice the weight of the next less significant bit. The least significant bit (LSB) is on the extreme right of the binary code.

Let us apply the binary weighing scheme to a d.c. voltage. Irrespective of the number of bits in the binary word to be converted, the MSB has to have twice the maximum weight, maximum value, importance or voltage capability as the next less significant bit. This means that if MSB can cause the output voltage to assume a value equal to one half of its maximum possible magnitude, then the next less significant bit must be able to cause the output voltage to change by one half of that value (MSB's value). Since the MSB changes the output by one half, therefore, the next less significant bit should be able to change the output by one fourth of the maximum possible.

Thus for an n bit converter :

$$\text{range of MSB} = \frac{1}{2} \times \text{range of converter and range of LSB} = \frac{1}{2^n} \times \text{range of converter}$$

The full scale output voltage of an n bit converter is given by :

$$E_0 = E_R \times (d_{n-1} \times 2^{-1} + d_{n-2} \times 2^{-2} + \dots + d_1 \times 2^{-(n-1)} + d_0 \times 2^{-n}) \quad \dots(26.68)$$

E_R can be any convenient reference analog value.

Thus there is a difference between E_0 and E_R and hence the error. The difference $E_0 - E_R$ decreases as the number of bits, n , increases.

$$\text{Resolution} = \text{analog value of LSB} = \frac{\text{full scale}}{2^n} \quad \dots(26.69)$$

Resolution is often specified in terms of percentage of full scale. The resolution of a converter can be conveniently related to its Dynamic Range expressed in db.

$$\text{Dynamic range} = 6 \times (\text{number of bits}) \text{ db.} \quad \dots(26.70)$$

Example 26.26. A 5 bit converter is used for a d.c. voltage range of 0–10 V. Find the weight of MSB and LSB. Also the exact range of the converter and the error. Find the error if a 10 bit converter is used.

Solution. Range of MSB = $\frac{1}{2} \times \text{range of converter} = \frac{1}{2} \times 10 = 5$ V.

$$\text{Range of LSB} = \frac{1}{2^5} \times \text{range of the converter} = \frac{1}{2^5} \times 10 = 0.3125 \text{ V.}$$

From Eqn. 26.62, the exact range of converter

$$E_0 = E_R(d_{n-1} \times 2^{-1} + d_{n-2} \times 2^{-2} + \dots + d_1 \times 2^{-n-1} + d_0 \times 2^{-n})$$

$$= 10(1 \times 2^{-1} + 1 \times 2^{-2} + 1 \times 2^{-3} + 1 \times 2^{-4} + 1 \times 2^{-5}) = 9.6875 \text{ V.}$$

$$\text{Error} = 10 - 9.6875 = 0.3125 \text{ V} = \frac{0.3125}{10} \times 100 = 3.125\%$$

The exact range of the converter when 10 bits are used is :

$$= 10(2^{-1} + 2^{-2} + 2^{-3} + 2^{-4} + 2^{-5} + 2^{-6} + 2^{-7} + 2^{-8} + 2^{-9} + 2^{-10}) = 9.99 \text{ V.}$$

$$\text{Error} = 10 - 9.99 = 0.01 = \frac{0.01}{10} \times 100 = 0.1\%$$

Thus if a large number of bits are used, the error reduces considerably. But the use of a converter with a large number of bits results in higher cost of the converter itself and also of the system where it is used. Also, a higher number of bits adds to the complexity of the system.

Example 27.27. A control valve has a linear variation of opening as the input voltage varies from 0 to 10 V. A microcomputer outputs an 8 bit output word to control valve opening using an 8 bit D/A converter to generate the valve voltage. (a) Find the reference voltage required to obtain full value opening (10 V) (b) Find the percentage of valve opening for a 1 bit change in the input word.

Solution. (a) With 8 bit A/D converter with all the bits being in 1 state, the output is 10 V.

$$\therefore 10 = E_R \left[\frac{1}{2} + \frac{1}{4} + \frac{1}{8} + \frac{1}{16} + \frac{1}{32} + \frac{1}{64} + \frac{1}{128} + \frac{1}{256} \right] \text{ or reference voltage } E_R = 10.0039 \text{ V.}$$

(b) Change in voltage due to change in LSB = $2^{-n} E_R = 2^{-8} \times 10 = 0.0392 \text{ V.}$

$$\therefore \text{Percentage change} = \frac{0.0392}{10} \times 100 = 0.392\%$$

Example 26.28. An analog voltage signal whose highest significant frequency is 1 kHz is to be digitally coded with a resolution of 0.01 per cent covering a voltage range of 0–10 V. Determine: (i) minimum number of bits in the digital code, (ii) analog value of LSB, (iii) rms value of the quantization error, (iv) minimum sampling rate, (v) aperture time required for the A/D converter and (vi) dynamic range of converter in db.

$$\text{Solution. (i) Resolution} = 0.01\% = \frac{0.01}{100} = \frac{1}{10000} = \frac{1}{2^n}$$

\therefore Minimum number of bits $n = 14$ as $2^{14} = 16384$ (we cannot choose $n = 13$ as $2^{13} = 8192$ which is less than 10000).

$$(ii) \text{ Analog value of } \text{LSB} = \frac{1}{2^n} \times 10 = \frac{1}{16384} \times 10 \text{ V} = 610.4 \text{ } \mu\text{V.}$$

(iii) Rms value of quantization error

$$E_q = \frac{Q}{2\sqrt{3}} = \frac{10}{(16384) \times 2\sqrt{3}} \text{ V} = 176 \text{ } \mu\text{V.}$$

(iv) In order that the signal may not be lost, the sampling frequency should be at least 5 times the highest frequency in the signal. \therefore Minimum sampling frequency $f_s = 5 f_h = 5 \times 1 = 5 \text{ kHz.}$

$$(v) \text{ From Eqn. 26.61, aperture time } t_a = \frac{\Delta E}{2\pi f E_m}$$

$$\text{but } \Delta E/E_m = 1/16384 \quad \therefore t_a = \frac{1}{2\pi \times 1 \times 10^3} \times \frac{1}{16384} \text{ s} = 9.71 \text{ ns.}$$

(vi) Dynamic range of converter = $6 \times \text{number of bits} = 6 \times 14 = 84 \text{ db.}$

26.23. Digital-to-analog (D/A) Conversion

It would seem logical to commence discussion of A/D and D/A conversion techniques with a presentation of A/D converters. In practice, however, some popular A/D conversion techniques use D/A converters for functioning. Therefore, we start with discussion on D/A converters first. The D/A converters are, no doubt, used as the basis of some A/D converters but they have a large important uses in their own right. Among these uses are computer driven CRT displays, digital generation of analog waveforms, and digital control of automatic process control systems.

The voltage output of an n bit converter is :

$$E_0 = (d_{n-1}2^{-1} + d_{n-2}2^{-2} + \dots + d_12^{-(n-1)} + d_02^{-n}) E_R \quad \dots(26.71)$$

where co-efficients d_n represent the binary word and d_n is either 1 or 0 if the n th bit is 1 or 0. The MSB corresponds to d_{n-1} and its weight is $E_R/2$ while the LSB corresponds to d_0 and its weight is $E_R/2^n$.

Eqn. 26.71 can be written as :

$$\begin{aligned} E_0 &= (d_{n-1}2^{n-1} + d_{n-2}2^{n-2} + \dots + d_12^1 + d_02^0) \frac{E_R}{2^n} \\ &= (d_{n-1}2^{n-1} + d_{n-2}2^{n-2} + \dots + d_12 + d_0) \frac{E_R}{2^n} \end{aligned} \quad \dots(26.72)$$

Let us consider a 5 bit converter. For this, $n=5$ and we have :

$$E_0 = (16d_4 + 8d_3 + 4d_2 + 2d_1 + d_0) \frac{E_R}{32}$$

Let us consider binary number 10000. Its decimal equivalent is 16.

For this $d_4=1$ and $d_3=d_2=d_1=d_0=0$.

$$\therefore E_0 = (16+0+0+0+0) \frac{E_R}{32} = 16 \frac{E_R}{32}$$

Let us consider another binary number 11000. Its decimal equivalent is 24.

For this number $d_4=d_3=1$ and $d_2=d_1=d_0=0$.

$$\therefore E_0 = (16+8+0+0+0) \frac{E_R}{32} = 24 \frac{E_R}{32}$$

Similarly for binary number 11001, the decimal equivalent is 25 and the output is :

$$E_0 = (16+8+0+0+1) \frac{E_R}{32} = 25 \frac{E_R}{32}$$

If all the 5 bits are 1, the decimal equivalent is 31 and the output is :

$$E_0 = (16+8+4+2+1) \frac{E_R}{32} = 31 \frac{E_R}{32}$$

The above analysis shows that the analog output voltage is proportional to the digital input.

26.24. D/A Converter

Fig. 26.72 shows a binary weighted resistance D/A converter. This converter consists of the following major components :

(i) *Switches*. There are n switches, one for each bit. These are : $S_{n-1}, S_{n-2}, \dots, S_1, S_0$.

(ii) *Resistances*. There is a resistive network of n resistors. One resistor is connected in the input circuit of each bit. The resistances are weighted i.e., if the resistance in the circuit for

MSB is R , the resistance in the circuit of next significant bit is $2R$ and so on. The resistance in the LSB circuit is $2^{n-1} R$.

(iii) *Reference Source.* The voltage of the reference source is E_R and is stable.

(iv) *Current to voltage converter.* It is an operational amplifier that adds up the currents flowing in the resistive network to develop an output analog voltage signal which is proportional to the digital input signal.

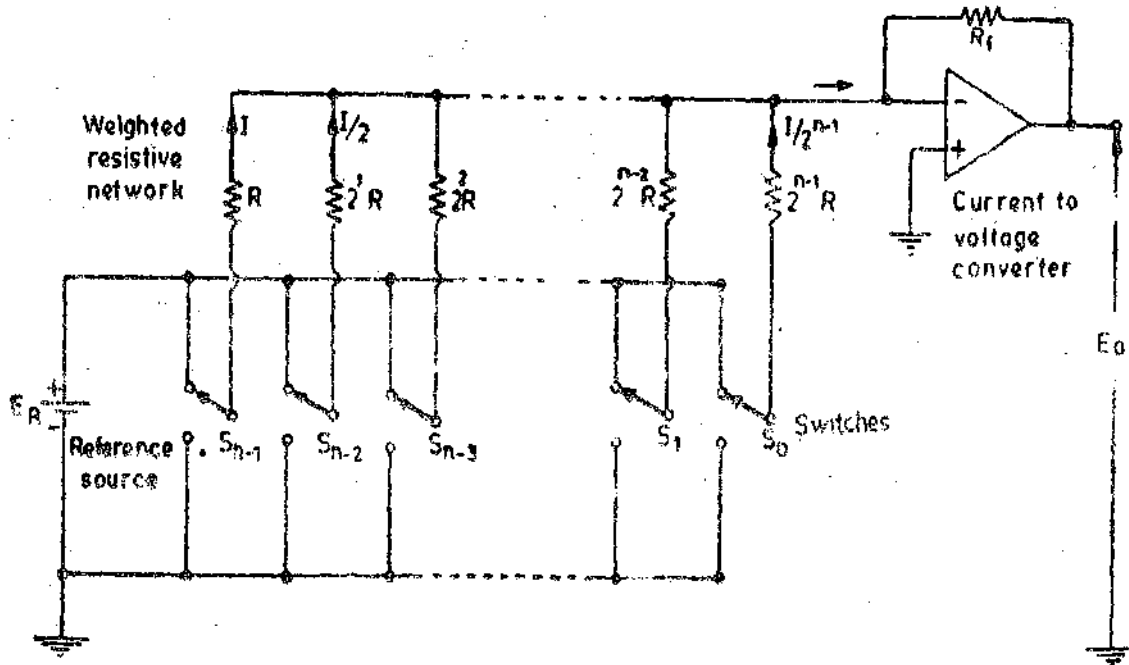

Fig. 26.72. Binary weighted resistance D/A converter.

Suppose switch S_{n-1} is connected to positive end of the reference source and rest of the switches are earthed. Under the conditions only MSB is 1 and the rest are 0. Therefore output voltage E_0 should be equal to $E_R/2$ for proper digital to analog conversion.

or
$$\frac{E_0}{E_R} = \frac{R_f}{R}, \text{ but } \frac{E_0}{E_R} = \frac{1}{2} \text{ or } \frac{R_f}{R} = \frac{1}{2}$$

∴ Resistance in the feedback circuit of OPAMP is : $R_f = R/2$.

Now suppose for a binary input MSB=1 and also the next significant figure is also 1 with the rest equal to 0.

Under these conditions
$$E_0 = \left(\frac{1}{2} + \frac{1}{2^2} \right) E_R = 0.75 E_R$$

Suppose R_1 is the resistance in the circuit of the bit next MSB.

∴ Input resistance for OPAMP
$$R_i = \frac{R R_1}{R + R_1}$$

$$E_0 = \frac{R_f}{R_i} E_R = 0.75 E_R \text{ or } \frac{R_f}{R_i} = 0.75 \text{ or } \frac{R}{2R_i} = 0.75$$

or
$$R_i = \frac{R}{1.5} \text{ but } R_i = \frac{R R_1}{R + R_1} \therefore \frac{R R_1}{R + R_1} = \frac{R}{1.5} \text{ or } R_1 = 2R.$$

Suppose all the bits in a n bit converter are 0 except for LSB which is 1

Suppose R_n is the resistance in the LSB circuit.

Output voltage for LSB, $E_0 = \frac{E_R}{2^n}$

Therefore, for proper digital to analog conversion $E_0 = \frac{R_f}{R_i} E_R$

But $E_0 = \frac{E_R}{2^n}$, $R_f = \frac{R}{2}$ and $R_i = R_n$ $\therefore \frac{E_R}{2^n} = \frac{R}{2} \times \frac{1}{R_n} \times E_R$

Hence $R_n = 2^{n-1}R$

It is evidently clear from above that if proper digital to analog conversion is to be carried out, the resistive network should be weighted as shown in Fig. 26'72.

Output current

$$I_0 = \left(1 + \frac{I}{2} + \frac{I}{2} + \dots + \frac{I}{2^{n-2}} + \frac{I}{2^{n-1}} \right) = I \left(1 + \frac{1}{2} + \frac{1}{4} + \dots + \frac{1}{2^{n-2}} + \frac{1}{2^{n-1}} \right)$$

$$= \frac{E_R}{R} \left(1 + \frac{1}{2} + \frac{1}{4} + \dots + \frac{1}{2^{n-2}} + \frac{1}{2^{n-1}} \right) \dots(26'73)$$

This is true only if all the bits are 1.

The general expression is : $I_0 = \frac{E_R}{R} \left[d_{n-1} + \frac{d_{n-2}}{2} + \frac{d_{n-3}}{4} + \dots + \frac{d_1}{2^{n-2}} + \frac{d_0}{2^{n-1}} \right] \dots(26'74)$

The output current is maximum when all the bits are 1.

\therefore Maximum output current $I_{max} = \frac{E_R}{2^{n-1}R} (2^n - 1) \dots(26'75)$

In practical D/A circuits, the resistive network, called a DAC, (digital to analog conversion module), is connected to a* flip flop register which holds the digital number. As the divider is simply a passive network, the digital input voltage (the on and off levels) determines the output voltage. Because digital voltage levels are usually not as precise as required in an analog system, level amplifiers may be placed between the flip flop register and the divider network. These amplifiers switch the inputs to the divider network between ground and a reference voltage supplied by a precision reference source. The analog output voltage then falls between these two levels.

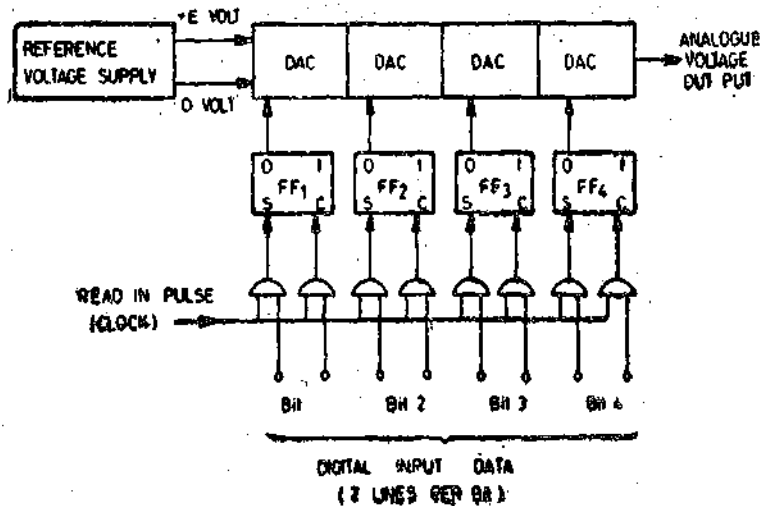

Fig. 26'73. Analog to digital converter.

A practical digital to analog converter is shown in Fig. 26'73. The basic components are :

- (i) Flip flop (FF) register.
- (ii) DAC modules which include level amplifiers and reference supplies.

The digital signals are dropped into the register by a read in pulse (usually a clock pulse). These pulses are automatically converted by the DAC network to analog voltage.

* A flip flop (FF) circuit is a bistable multivibrator as explained in chapter 28 page 911.

Example 26.29. A D/A converter has 6 bits and a reference voltage of 10 V. Calculate the minimum value of R such that the maximum value of output current does not exceed 10 mA. Find also the smallest quantized value of output current.

Solution.

From Eqn. 26.75, the minimum value of $R = \frac{E_R \times (2^n - 1)}{2^{n-1}} \times \frac{1}{I_{max}}$

$$= \frac{10 \times (2^6 - 1)}{2^5} \times \frac{1}{10 \times 10^{-3}} = 1969 \Omega \approx 2 \text{ k}\Omega.$$

Current with LSB = $\frac{E_R}{2^{n-1}R} = \frac{10}{2^5 \times 2000} = 156 \times 10^{-6} \text{ A} = 156 \mu\text{A}.$

Example 26.30. Consider a 6 bit D/A converter with a resistance of 320 kΩ in LSB position. The converter is designed with weighted resistive network. The reference voltage is 10 V. The output of the resistive network is connected to an OPAMP with a feedback resistance of 5 kΩ. What is the output voltage for a binary input of 111 010 ?

Solution.

Output current $I_0 = \frac{E_R}{R} \left[\frac{d_{n-1}}{2} + \frac{d_{n-2}}{2^2} + \dots + \frac{d_1}{2^{n-2}} + \frac{d_0}{2^{n-1}} \right]$

Now $n=6 \therefore$ Resistance in LSB = $2^{n-1}R = 2^5 R = 320 \text{ k}\Omega$ or $R = 10 \text{ k}\Omega.$

Hence output current .

$$\frac{10}{10 \times 10^3} \left[1 \times 1 + 1 \times \frac{1}{2} + 1 \times \frac{1}{4} + 0 \times \frac{1}{8} + 1 \times \frac{1}{16} + 0 \times \frac{1}{32} \right] \text{ A} = 1.8125 \text{ mA}.$$

Therefore, output voltage $E_0 = I_0 R_f = 1.8125 \times 10^{-3} \times 5 \times 10^3 = 9 \text{ V}.$

26.25 Analog to Digital (A/D) Conversion Techniques

Analog to digital (A/D) conversion is slightly more complex than digital-to-analog (D/A) conversion. A number of methods may be used for this purpose. The following four methods are most commonly used :

- (i) Successive approximation method (potentiometric type)
- (ii) voltage to-time conversion method, (ramp type)
- (iii) voltage to frequency conversion method, (integration type)

and (iv) dual slope integration method.

26.25.1. Potentiometric A/D Converter. The potentiometric A/D converter is probably the most widely used in general practice on account of its high resolution and high speed. The potentiometric type A/D converter works on the principle of successive approximation. This converter compares the analog input to a Decade Assembly Counter (DAC) reference voltage which is repeatedly divided in half. The process is shown in Fig. 26.74, where a four digit binary number 1000, representing the full reference voltage E_r , is divided in half (binary number 100), to corresponding voltage

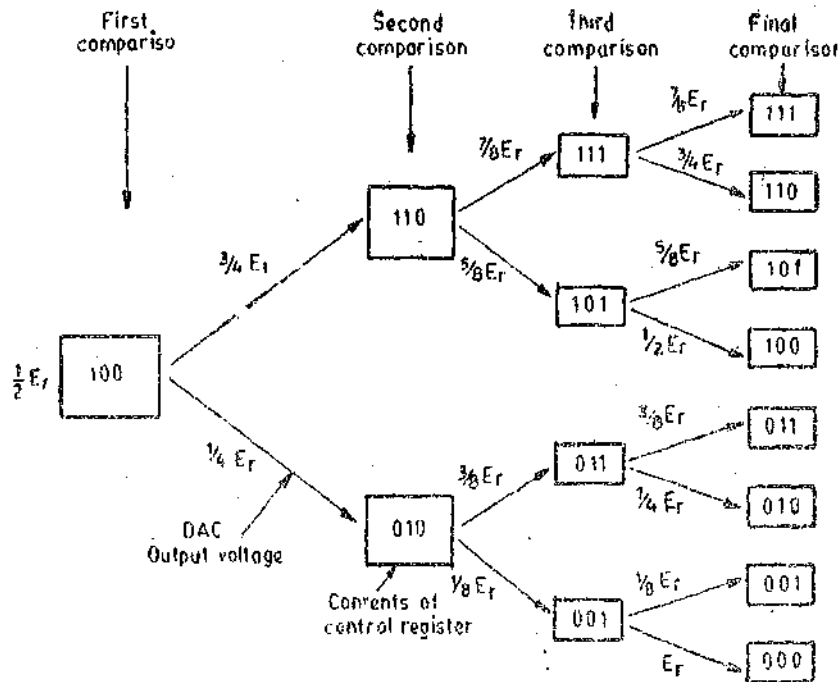

Fig. 26'74. Operation of successive approximation A/D converter.

$\frac{1}{2}E_r$. A comparison of this reference voltage $\frac{1}{2}E_r$ and the analog voltage is made. If the result of this comparison shows that this first approximation is too small (i.e. $\frac{1}{2}E_r$ is smaller than the analog input), then the next comparison is made against $\frac{3}{4}E_r$ (binary number 010). After four successive approximations the digital number is resolved.

The potentiometric A/D converter circuit block diagram is shown in Fig. 26'75. It contains a voltage divider network with coarse and fine steps. The voltage divider network is connected through electronic switches to a voltage comparator which compares an internal voltage provided by a reference source with an unknown voltage. The output of the comparator, which is an error signal is fed to logic circuits which operate switches to control the steps on the voltage divider network. The measurement sequence usually selects the largest steps of the internal voltage first. The magnitude of the steps decreases until the null point is reached. The output is read on a digital counter (explained in chapter 28 page 913).

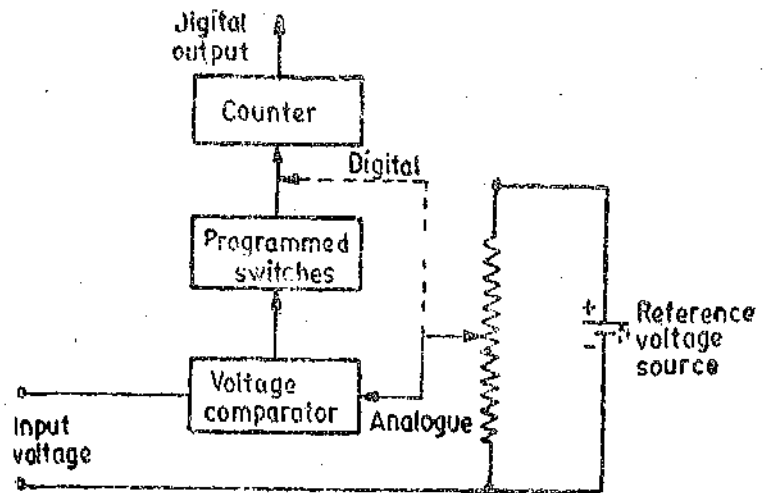

Fig. 26'75. Potentiometric A/D Converter.

A generalized block diagram of a basic successive approximation converter is shown in Fig. 26'76. The converter uses a digital control register with gateable binary inputs of 1 and 0, a D/A converter with a reference voltage supply, a comparison circuit, a control timing loop, and a distribution register. The distribution register is like a ring counter with a single 1 circulating in it to determine which step is taking place.

At the start of conversion cycle, both the control register and the distribution register are set with a 1 in the MSB and a 0 in all bits of less significance. Thus the distribution register shows that the cycle has started and the process is in its first phase. The control register shows 1000, and this causes an output voltage at the D/A converter section of one half of reference supply. At the same

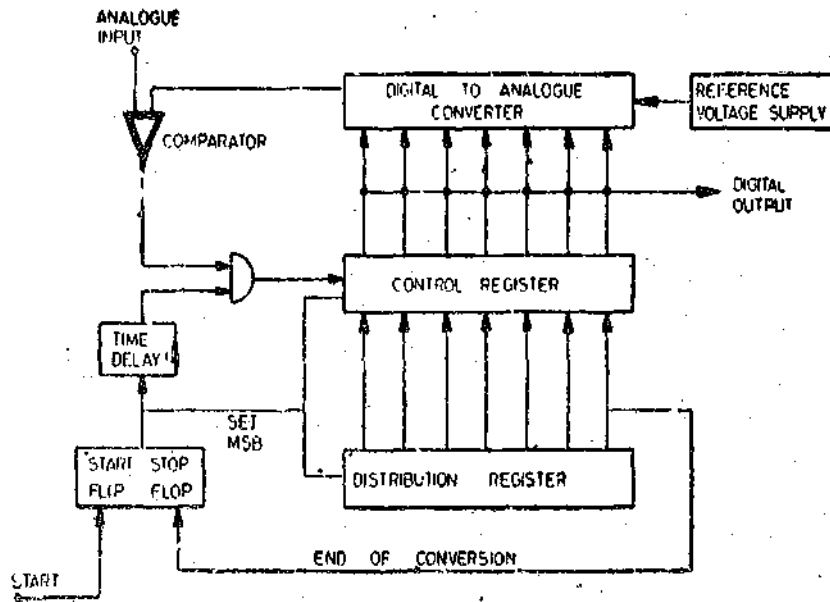

Fig. 26'76. Simplified block diagram of the successive approximation A/D converter.

time, a pulse enters the time delay circuitry. By the time that the D/A converter and the comparator have settled, this delayed pulse is gated with the comparator output.

When the next MSB is set in control register by the action of the timing circuit, the MSB remains in the 1 state or it is reset to 0 depending upon the comparator output. The single 1 in the distribution register is shifted to the next position and keeps track of the comparison made.

The procedure repeats itself following the diagram of Fig. 26'76, until the final approximation has been corrected and the distribution register indicates the end of the conversion.

For a successive approximation converter, the digital output corresponds to some value that the analog input had during the conversion. Thus the aperture time is equal to the conversion time. The aperture time can be reduced by using Sample Hold (S/H) circuit.

Example 26'31. Find the successive approximation A/D output for a 4 bit converter to a 3'217 V input if the reference is 5 V.

Solution. (i) Set $d_3=1$. \therefore Output $= 5/2^1 = 2.5$ V.

Now $3.217 > 2.5$ and \therefore Set $d_3=1$.

(ii) Set $d_2=1$ \therefore Output $= 2.5 + \frac{5}{2^2} = 3.75$

Now $3.217 < 3.75$ \therefore Set $d_2=0$

(iii) Set $d_1=1$ \therefore Output $= 2.5 + \frac{5}{2^3} = 3.125$

Now $3.125 < 3.217$ \therefore Set $d_1=1$

(iv) Set $d_0=1$ \therefore Output $= 3.125 + \frac{5}{2^4} = 3.4375$

Now $3.4375 > 3.217$ \therefore Set $d_0=0$

Thus output of A/D converter is : 1010.

26'25.2. Voltage to time A/D Converter (Ramp type) : This type of A/D converter utilizes digital counter techniques to measure the time required for a voltage ramp to rise from zero to the input voltage level. The time, however, may be for the ramp to drop down from the input voltage level to zero. Thus this converter may be used, when the ramp is either positive going or negative going.

A well defined, internally generated ramp voltage, is fed to two voltage comparators as shown in Fig. 26.77. The ramp voltage may have either a negative or a positive going slope. Let us consider a ramp voltage with a positive going slope. When the input voltage is equal to the ground voltage, the ground comparator emits a start signal to a gate which opens and permits the passage of pulses of a clock (1 MHz) from a crystal oscillator to a digital counter. When the ramp voltage is equal to the level of the input voltage of the second comparator it produces a signal to close the gate and thus further count is prevented.

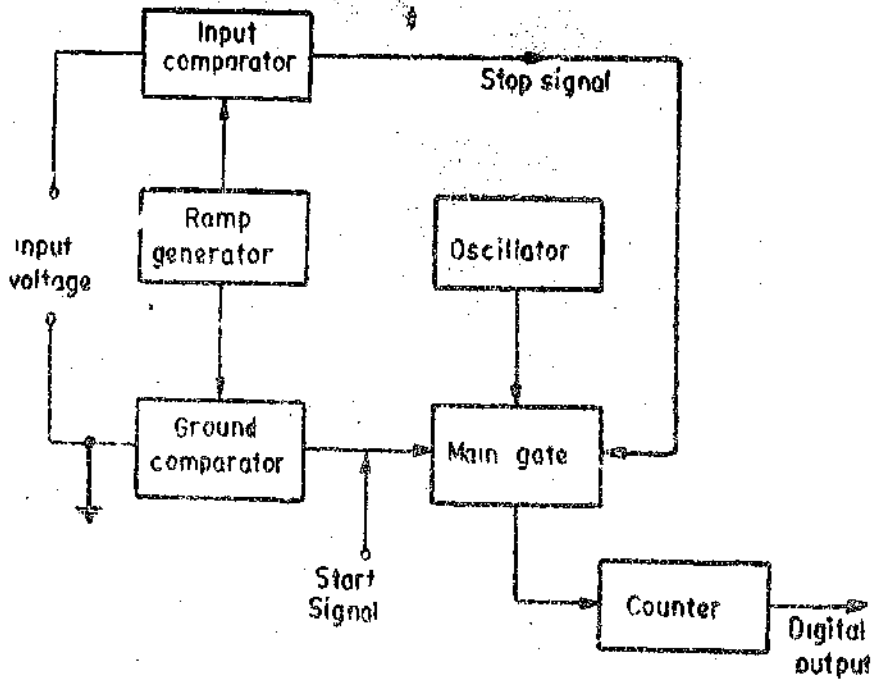
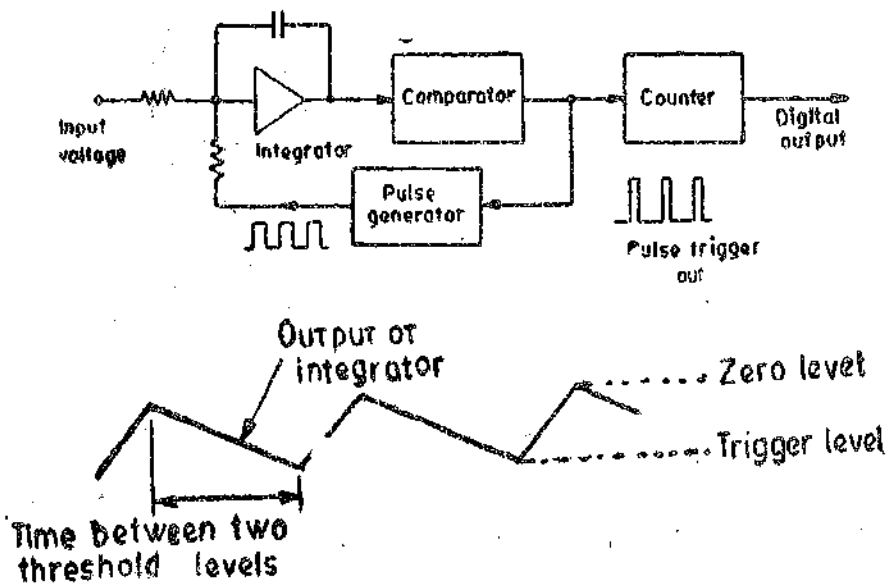

Fig. 26.77 Voltage to time A/D converter.

The count, with suitable scaling, may be made equal to magnitude of the difference in the two input voltage levels of the input voltage.

26.25.3. Voltage-to-Frequency Converter (integrating type). A block diagram representation of a voltage to frequency converter is shown in Fig. 26.78. The analog input is applied to an integrator. The integrator produces a ramp signal whose slope is proportional to the input voltage signal level. When this ramp signal reaches a preset threshold level, a trigger pulse is produced. Also a



26.78. Voltage to frequency A/D converter (integrating type).

current pulse is produced which discharges the capacitor of the integrator, after which a new ramp is initiated.

The time between successive threshold level crossings is inversely proportional to the slope of the ramp. Since the slope of the ramp is proportional to the input analog voltage, hence the frequency of output pulses from the comparator is directly proportional to the input voltage. The output frequency may be measured with the help of a digital frequency counter. Frequency counters are explained in chapter 28.

26.25.4. Dual Slope Integration A/D Converter. The block diagram of a dual slope integration A/D Converter is shown in Fig. 26.79 (a). The reference voltage and the input analog voltage

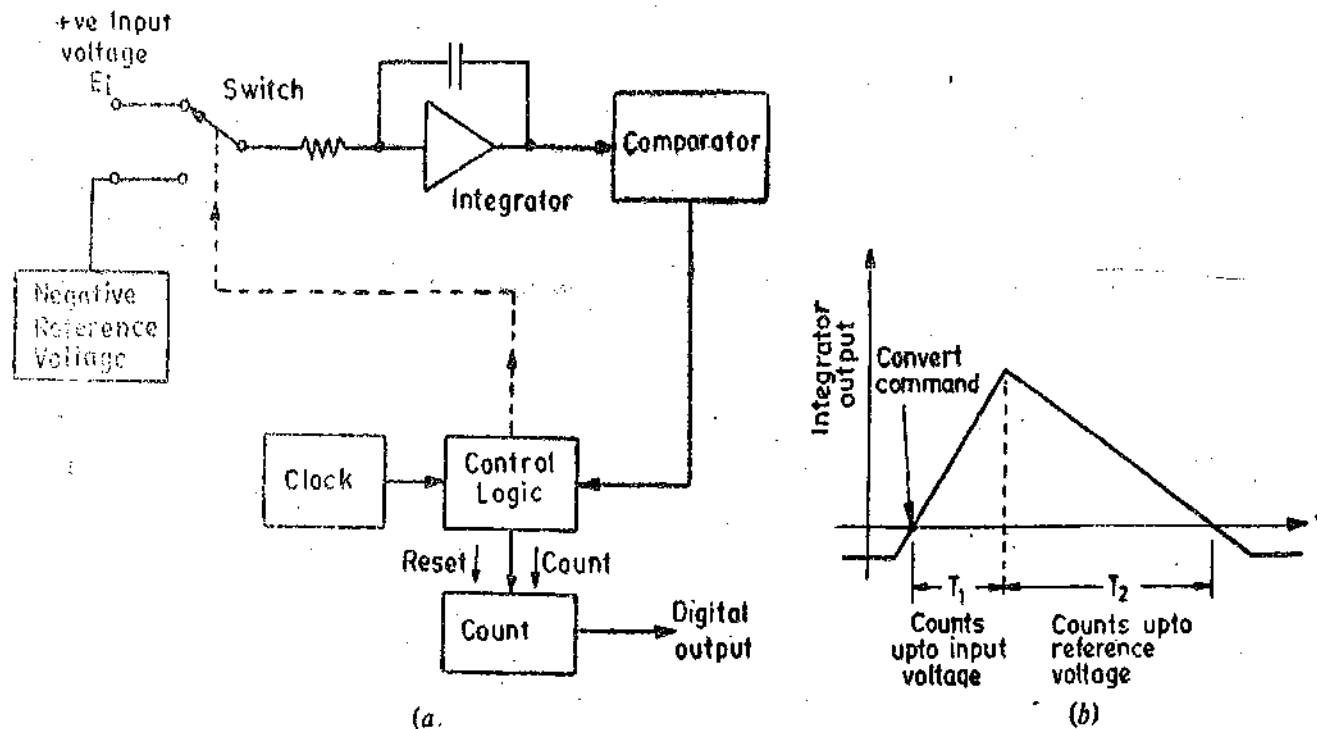

Fig. 26.79. Dual slope A/D converter

are sequentially connected to the integrator with the help of a switch. The reference voltage and the input analog voltage must be of opposite polarity. The input voltage is integrated for a fixed input sample time. The integrated value is then discharged at a fixed rate and the time to do this is measured by a counter.

Two types of commands are given by the logic control to the counter and they are : (i) Reset and (ii) Convert.

When a convert command is received by the counter, it automatically resets to all zeros and the switch connects the input voltage to the integrator. The output from the comparator is designed such that at this time it will permit the counter to count up for a output from the integrator will be steadily increasing in value.

On the next count after the converter has counted all the way up to all 1s (i.e. the next count will cause it to go all zeros and start over again), the switch changes position. The input voltage is disconnected and the switch connects the reference voltage to the integrator. Therefore the integrator now integrates the opposite polarity voltage, which causes the output to decrease towards zero voltage. Meanwhile, the counter is counting up from zero again.

When the output of the integrator goes to zero, it causes the comparator to switch its output, thereby stopping the counter via the control logic. The binary number in the counter at this time is proportional to the amount of time that it took the integrator to integrate down from its starting point to zero. Therefore, the binary count is proportional to input voltage. Fig. 26.79 (b) illustrates the output from the integrator during a conversion cycle. The difference in the slopes of the curve is due to difference in voltage level of input voltage E_i and reference voltage E_r .

Suppose T_1 = counts when the input voltage is applied.

T_2 = counts when the reference voltage is applied.

$$\therefore \text{Input voltage is : } E_i = \frac{T_2}{T_1} \times E_r. \quad \dots(26.76)$$

UNSOLVED PROBLEMS

- An amplifier has an input voltage of 1 mV and an output voltage of 1.6 V. Express the gain of amplifier in db. [Ans. 64 db]
- A data sheet of an amplifier specifies that the voltage gain is 40 db. If three such amplifiers are cascaded, what is the overall gain in db and expressed as an ordinary number? [Ans. 120 db, 10⁶]
- The scale of a voltmeter is calibrated in decibels with a reference voltage of 0.775 V. What is the actual voltage if the voltmeter reads 12 db? [Ans. 3.1 V]
- A differential amplifier has two inputs +100 mV and +250 mV connected to its two terminals. The output voltage is +1.5 V. What is the gain? [Ans. 10]
- A differential amplifier with a difference mode gain of 20 has +100 mV applied to terminal 1 and -250 mV applied to terminal 2. What is the output signal? [Ans. 7 V]
- A differential amplifier has an input $e_1 = +150$ mV and $e_2 = +150$ mV. If this amplifier was an ideal one, what would its output be? Suppose the amplifier is not ideal but instead, has an output of 1.5 mV. What is the value of its common mode gain? [Ans. zero, 0.01]
- A differential amplifier has a difference mode gain of 1000 and common mode gain of 0.05. What is the value of the common mode rejection ratio? [Ans. 20,000]
- A balanced output source provides a signal of 50 mV from each terminal to ground. There is a hum pickup of 5 mV (common mode signal) on each terminal. A differential amplifier of differential gain of 20 and a CMRR of 25000 is used to amplify the signal. (a) What is the ratio of signal to hum at the amplifier input? (b) What is the ratio of signal to hum at the output? [Ans. (a) 1, (b) 8×10^{-9}]
- Three signals are to be added together without changing their values. The feedback resistance is 1 k Ω , what values should R_1 , R_2 , R_3 be? [Ans. 1 k Ω each]
- The input signal to an operational amplifier acting as a differentiator is: $e = 10 \sin 20t + 0.1 \sin 377t$. What is the signal to noise ratio before and after differentiation? [Ans. 100, 5.3]
- A capacitive transducer uses air as dielectric medium. It has plates of 250 mm² area and is connected in the feedback of an operational amplifier having an input capacitance of 150 pF. The voltage output is 1 V. Calculate the change in displacement between plates. The applied input voltage is 10 V. [Ans. 1.475 μ m]
- A simple R.C. filter has a resistance equal to 100 k Ω and a capacitance equal to 500 pF. Sketch the asymptotic response. [Ans. Cutoff frequency = 3.18 kHz; The slope at 31.8 kHz = -20 db]
- A low pass filter intended to have its 3 db point at 50 kHz is to be added at the output of an amplifier. The amplifier's internal resistance is 3000 Ω . What size capacitor should be connected in parallel with the amplifier's output terminals?
- Design a high-pass filter with a characteristic resistance of 50 Ω and a cut off frequency of 20 MHz, and an attenuation of 80 db at 5 MHz. [Ans. Inductance = 0.398 μ H, capacitance $C = 159$ pF, L sections = 3; Use T filter]
- Using Fig. 26.52, the following values apply:
 $R_1 = 500 \Omega$, $R_2 = 100 \text{ k}\Omega$, $C_1 = 680 \text{ pF}$ and $C_2 = 0.1 \mu\text{F}$.
Find the approximate passband gain and cutoff frequencies. [Ans. 0.995, 15.9 Hz, 468 Hz]
- Find the notch frequency of the twin T network of Fig. 26.54 for $R = 50 \text{ k}\Omega$ and $C = 2000 \text{ pF}$. [Ans. 1.59 kHz]
- A notch filter is to be built to prevent an undesired signal at 2 MHz from entering an electronic system. If an inductance of 1 mH is used, what value of the capacitance will be required? [Ans. 6.33 pF]
- A metallic strain gauge made of aluminium has a nominal resistance of 120 Ω . It is connected in series with a ballast resistor of 120 Ω in a voltage sensitive circuit. The input voltage to the circuit is 30 V. Calculate the change in the output voltage across the gauge when the stress of 100 MN/m² is applied to it. The modulus of elasticity of aluminium is 70 GN/m². The gauge factor is 1.6. [Ans. 17.1 mV]

19. The output of a resistive transducer with a total resistance of 150Ω is to be measured with a voltage sensitive circuit. The sensitivity is to be maximum at the midpoint of the transducer. Calculate the sensitivity at the 25 and 75 percent positions if the voltage of the input source is 100 V. [Ans. 0.592 V/ Ω , 0.213 V/ Ω]

20. A strain gauge circuit uses a ballast resistance. The resistance of the gauge, when unstrained, is 1000Ω while that of series ballast resistance is 3000Ω . The supply voltage is 135 V. Calculate the value of the change in the voltage across the strain gauge when the applied strain is 0.001 m/m. The gauge factor is 3.5. [Ans. 88 mV]

21. A Wheatstone bridge is shown in Fig. 26.62. The resistances are $R_1=9725 \Omega$, $R_2=8820 \Omega$, $R_3=8550 \Omega$ and $R_4=9875 \Omega$.

(a) If the bridge is voltage sensitive type and if the input voltage is 24 V. What is the meter reading connected at the output terminals?

(b) If R_3 is variable, what value should it have for null balance? [Ans. (a) 1.45 V (b) 10888 Ω]

22. Calculate the possible error in the measurement of a resistance of 1Ω using a null type Wheatstone bridge if the accuracy of bridge ratio is $\pm 0.05\%$ and that of the variable resistor is $\pm 0.03\%$. [Ans. $\pm 0.0008 \Omega$]

23. For the basic Wheatstone bridge shown in Fig. 26.62, determine the uncertainty in the measured value of R_1 as a result of uncertainty of 1 percent in the known resistance. Repeat for an uncertainty of 0.05 per cent. [Ans. 1.732%, 0.0866%]

24. The bridge of Fig. 26.62 has $R_1=6000 \Omega$, $R_2=600 \Omega$, $R_3=340 \Omega$. A galvanometer with a resistance of 70Ω and a sensitivity of $0.04 \mu\text{A}/\text{mm}$ is connected between terminals B and D. The galvanometer deflection is 39 mm and the battery voltage is 4 V. Calculate the value of R_4 . Repeat with $R_1=60 \Omega$ and $R_2=600 \Omega$. [Ans. 33.93 Ω , 33.98 Ω]

25. Determine the output voltage and current respectively for 1% change in input resistance of voltage and current sensitive equal arm bridges respectively having a resistance of 100Ω in each arm initially. The supply voltage is 6 V and the resistance of the galvanometer is 200Ω . [Ans. 15 mV, 50 μA]

26. A current sensitive bridge is shown in Fig. 26.62. The initial value of the transducer resistance $R_1=R$ and the other resistors have a value of $R_2=10 R$, $R_3=R$ and $R_4=10 R$. The output of the bridge is connected to the galvanometer of an ultraviolet recorder having an input resistance of 100Ω . Determine the sensitivity of the bridge in ampere per percentage change in resistance. The initial value of the transducer resistance is 500Ω and the bridge supply voltage is 4 V. [Ans. 5.96 $\mu\text{A}/\%$ change of R]

27. A thermistor of resistance 1000Ω at 50°C temperature is connected in a bridge circuit having all arms of resistance 1000Ω . The supply voltage to the bridge is 40 V. The resistance of the thermistor increases by 5Ω for a decrease of temperature of 1°C . Find the temperature if the open circuit voltage of the bridge is 50 mV. [Ans. 49°C]

28. An equal arm bridge has $R=10 \text{ k}\Omega$. The supply voltage to bridge is 30 V. An amplifier with a gain of 26 db is connected across the output. Find the change in output voltage of the amplifier if the resistance change in one of the arms is 50Ω .

$$[\text{Ans. } 0.45 \text{ V. Hint: } e_o = \frac{(30 \times 50)/10000}{4 \left(1 + \frac{10,000}{15,000}\right)} = 0.0225 \text{ V.}]$$

$$\text{Gain} = \text{Antilog } \frac{26}{20} = 20 \therefore \text{output} = 20 \times 0.0225 = 0.45 \text{ V.}]$$

29. A good quality analog transducer having an input of 0–8 V is able to distinguish a change of 1 mV in its input signal. Calculate the number of bits the A/D converter should have in order to achieve a resolution not lower than that of the analog device. [Ans. 13 bits]

30. An analog voltage signal whose highest significant frequency is 500 Hz is to be coded with a resolution of 0.1 percent approximately covering a range of 0–10 V. Determine the: (i) number of bits in the digital code, (ii) analog value of LSB, (iii) r.m.s. value of quantization error, (iv) minimum sampling rate so that signal is lost, (v) aperture time required by A/D converter and (vi) dynamic range of converter in db. [Ans. 10 bits, 9.77 mV, 2.8 mV, 2.5 kHz, 31.1 μs , 60 db]

31. A 8 bit D/A converter has a reference voltage of 12 V. It uses a weighted resistive network. Find the minimum value of resistance R to be connected in the MSB input circuit such that the maximum output current does not exceed 10 mA. Also find the smallest quantized value of current. [Ans. 2.4 k Ω , 39.1 μA]

32. Temperature is to be measured by a transducer having a sensitivity of $0.02 \text{ V}/^\circ\text{C}$. Determine the required A/D converter reference and word size to measure 0– 100°C with 0.1°C resolution. [Ans. 2V, 10]

Data Transmission and Telemetry

27.1. Introduction

In modern measurement systems, the various components comprising the system are usually located at a distance from each other. It, therefore, becomes necessary to transmit data between them through some form of communication channels.

The terms **data transmission** and **telemetry** refer to the process by which the information regarding the quantity being measured is transmitted to a remote location for applications like data processing, recording or displaying. This may involve transduction of the quantity with the help of transducers and in addition, signal conditioning also.

27.2. Methods of Data Transmission

The transmission of a measured variable from the point of measurement to a remote point is an important function in instrumentation systems because of the size and complexity of modern industrial plants. The most common variable encountered in industrial plants are: temperature, pressure and flow. The measuring elements can be pressure springs, thermocouples, bellows, floats etc. Most measuring devices such as mercury thermometers, pressure gauges, or flow-rate meters would require fluid-line connections of great length. This cannot be done because it would result in excessive measuring lags. Hence some form of transmission must be employed.

The method employed for data transmission depends upon the variable and also the distance involved. In case the data is to be transmitted over a short distance, the following methods may be used:

- (i) Hydraulic transmission,
- (ii) Pneumatic transmission,
- and (iii) Electrical or Electronic transmission.

The hydraulic and pneumatic methods are useful for transmitting data over small distances and hence are limited in scope.

The electrical and electronic methods of data transmission are extensively used in industrial measurement and instrumentation systems. In this text data transmission by electrical and electronic means is only discussed.

27.3. Telemetry

Telemetry may be defined as measuring at a distance. In fact, according to ASA "telemetry is the indicating, recording or integrating of a quantity at a distance by electrical means". Several methods of classifying telemetry systems are used. IEEE bases its classification on the characteristics of the electric signal. This may be: (i) voltage, (ii) current, (iii) position, (iv) frequency, and (v) pulse.

Telemetry Systems may be classified as: (i) analog, and (ii) digital.

In addition, telemetry systems have been classified as:

- (i) short distance type, and (ii) long distance type.

Another classification may be based upon whether the user has control over transmission channel or not.

Table 27.1 shows a comparison between the above mentioned ways of classification. All of the IEEE's classifications can be used for short distance telemetry, but only the frequency

and the pulse types are suited to long distance telemetering. The voltage, current, position, frequency and pulse can be used for analog telemetry while only pulse type can be used for digital telemetering.

TABLE 27.1
Classification of Telemetering Systems

<i>IEEE Designation</i>	<i>Short distance</i>	<i>Long distance</i>	<i>Analog</i>	<i>Digital</i>
Voltage	yes	no	yes	no
Current	yes	no	yes	no
Position	yes	no	yes	no
Frequency	yes	yes	yes	no
Pulse	yes	yes	yes	yes

Voltage, current and position telemetering require a physical connection between the transmitter and the receiver. This physical connection is normally called a channel, which consists of one, two or more wires depending upon the system. In case of radio frequency (R.F.) telemetry, the channel is not a physical link.

The frequency and pulse systems can operate on a physical wire channel and also can utilize other channels such as telegraph, teletype, telephone, radio or microwave. Hence for long distance telemetering either frequency or pulse techniques are used.

27.4. General Telemetering System

A general telemetering system is shown in Fig. 27.1. The primary detector and end device of the telemetering system have the same functional positions as in any general measurement system. However, there are three system elements in the intermediate state which are peculiar to a telemetering system. They are :

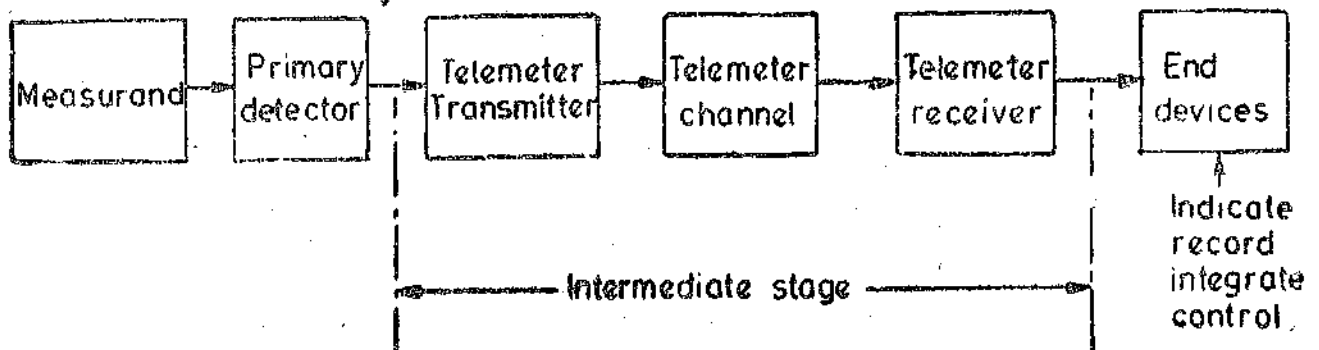

Fig. 27.1 Functional representation of a general telemetering system.

- (i) telemeter transmitter, (ii) telemeter channel, and (iii) telemeter receiver.

The function of the telemeter transmitter is to convert the output of a primary detector into a related quantity (translating means) which can be transmitted over the telemeter channel. The function of the telemeter receiver at the remote location is to convert the transmitted signal (translating means) into a related suitable quantity.

27.5. Electrical Telemetry Systems. The electrical telemetry systems consist of a transmitter which converts the measurand into an electrical signal that is transmitted through a telemetry channel and is received by a receiver located at a remote location. This signal is converted into a usable form by the receiver and is indicated or recorded by an end device which is graduated in terms of the measurand.

The electrical telemetry systems may be broadly classified as :

(i) d.c. systems and (ii) a.c. systems.

27.5. D.C. Telemetry Systems. The d.c. systems may be classified as :

(i) voltage telemetry systems, (ii) current telemetry systems, and (iii) position telemetry systems.

In d.c. telemetry systems, the signal is transmitted through a telemetry or communication channel which utilizes direct transmission via cables in order to convey the information. This is called **Land Line Telemetry**.

27.5.1. Voltage Telemetry Systems. A voltage telemetry system transmits the measured variable as a function of an a.c. or d.c. voltage. A simple voltage system is shown in Fig. 27.2. A slide wire potentiometer is connected in series with a battery. The sliding contact is positioned by a pressure sensitive bourdon tube. The telemetry channel consists of a pair of wires connected to a voltage measuring device such as a null balance d.c. potentiometer indicator or recorder. As the measured pressure changes, the bourdon tube actuates the sliding contact thereby changing the voltage. The d.c. null balance potentiometer measures the voltage and positions pointer on a scale calibrated in terms of the pressure being measured.

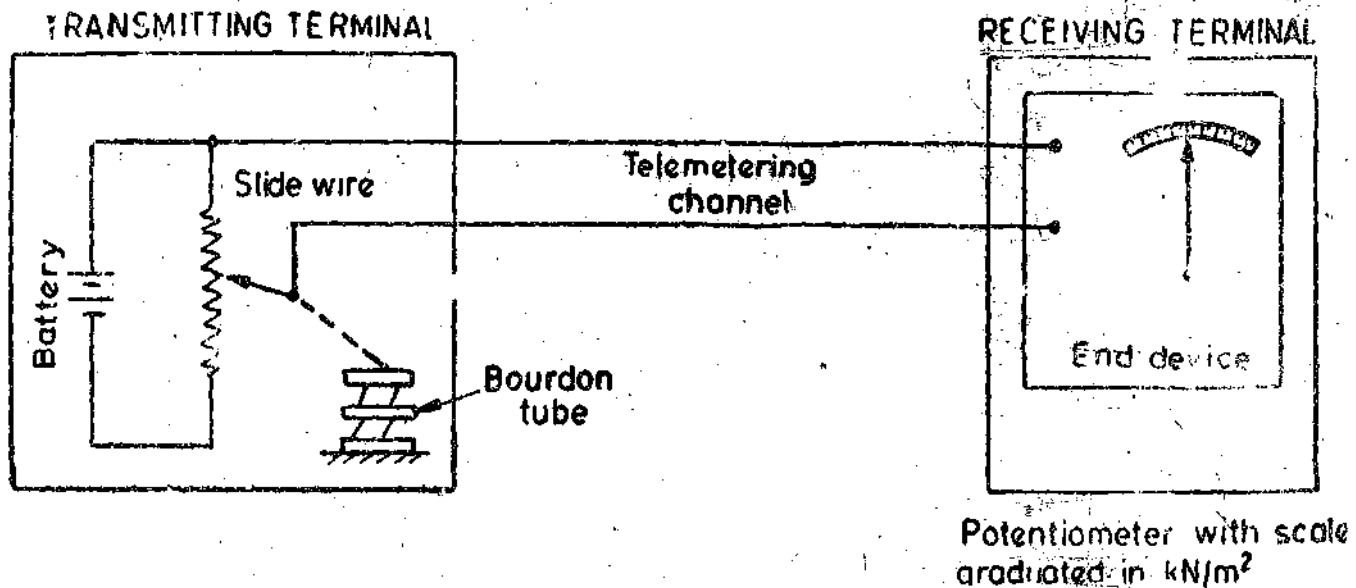

Fig. 27.2. Voltage telemetry system.

The use of a null balance d.c. potentiometer reduces the current carried by the telemetry (or communication) channel to minimum where the resistance is negligible.

Most of the systems use primary elements which produce a voltage signal. These elements include thermocouples, tachometers and differential transformers. The application of voltage systems in industrial plants is limited to distances up to about 300 metres. Self-balancing potentiometers are the usual receivers for such system. The deflection type of indicators may also be used if they are calibrated for the line resistance involved.

Voltage telemetry system requires high quality circuits than current systems. The signal to noise ratio (S/N) must be comparatively high. Since, the power level is small in voltage telemetry

systems, the transmission channel must be protected from sources of interference which are of the same order as that of the signal.

A voltage telemetering system is suitable for adding several output voltages in series. This is subject to the condition that the measurement is linear. However, the voltage system requires a relatively more expensive receiving end equipment. The system is generally not adaptable to the use of the many receivers at the same time.

27.5.2. Current Telemetering Systems. The earlier version of a current telemetering system is shown in Fig. 27.3. It has a slidewire potentiometer connected in series with a battery. The sliding contact of the potentiometer is positioned by a pressure sensitive bourdon tube. The telemetering channel consists of a pair of wires connected to a current measuring device.

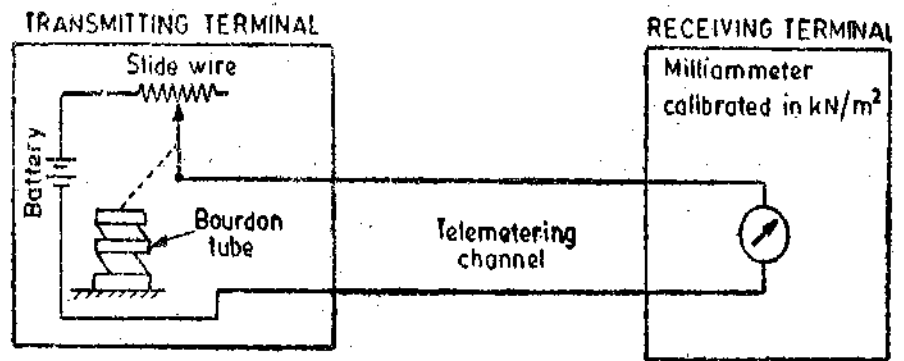

Fig. 27.3. Basic current telemetering system.

As the pressure, which is the measurand, changes the bourdon tube moves and changes the position of the sliding contact on the slide wire, thereby changing the current in the circuit. This current is measured with the help of a milliammeter whose scale is graduated terms of pressure.

The commonly used current telemetering systems are motion and force balance types which are improved forms of the basic current telemetering system described above.

In a Motion Balance System the slide wire is replaced by a position detector like an LVDT as shown in Fig. 27.4. A capacitive transducer may also be used.

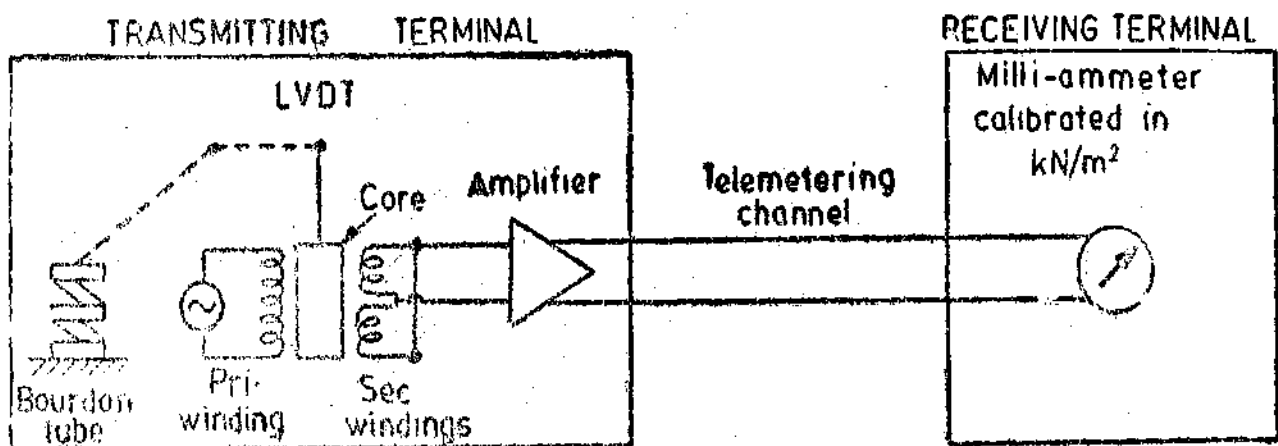

Fig. 27.4 Motion balance current telemetering system.

The pressure acting on the bourdon tube causes a displacement which moves the core of the LVDT, thereby producing a voltage output which is amplified and rectified. This voltage produces a d.c. current of the order of 4 to 20 mA in the telemetering channel and is measured by a d.c. milli-ammeter. The scale of the d.c. milli-ammeter is directly calibrated in terms of pressure being measured.

A Force Balance System is shown in Fig. 27.5. In this system, a part of the current output is fed back to oppose the motion of the input variable. The system is operated by the bourdon tube which rotates the feedback force coil which in turn changes the flux linkages between the primary and the secondary coils. This change in flux linkages varies the amplitude of the amplifier. The output signal is connected to the feedback force coil which produces a force opposing the bourdon tube input.

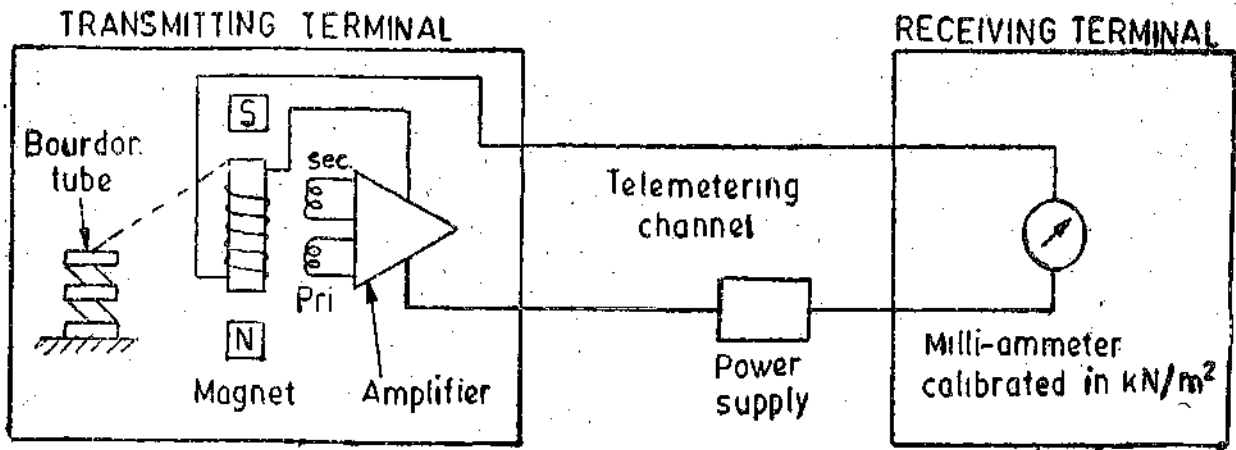

Fig. 27.5 Force balance current telemetering system.

A force balance system increases the accuracy as smaller motions are required which result in better linearity.

27.5.3. Position Telemetering System. A position telemetering system transmits and reproduces the measured variable by positioning variable resistors or other electrical components in a bridge circuit form so as to produce proportional changes at both the transmitter and the receiver ends. This is known as Bridge type System.

Fig. 27.6 shows two potentiometers, one at transmitting end and the other at the receiving end. The two potentiometers are energized by a common power supply. The sliding contact at the transmitting end is positioned by the bourdon tube as pressure is applied to the latter. If the sliding contact at the receiving end is positioned until the centre zero galvanometer indicates zero, the position of the contact will assume the same position as the contact at the transmitter. The receiving contact moves the pointer which indicates on the scale the pressure which is being measured (the scale is directly calibrated in terms of pressure). The principle involved is the same as that of a Wheatstone bridge.

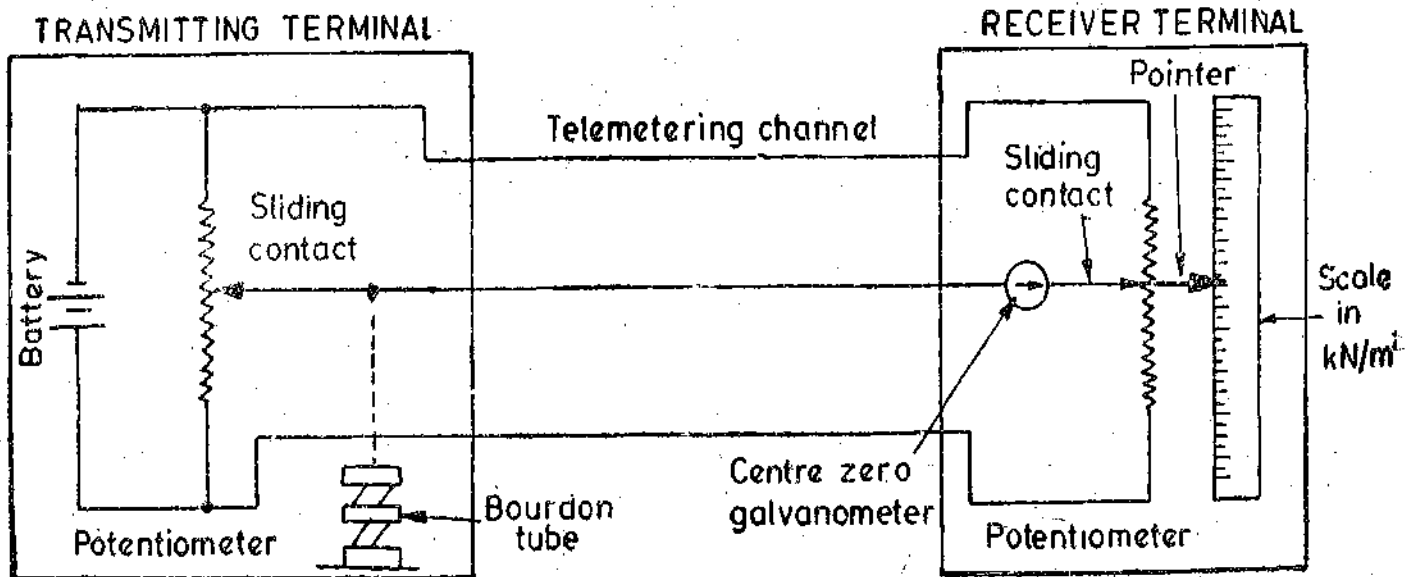

Fig. 27.6. Position telemetering system using a bridge type configuration.

Another most commonly used position telemetry system utilizes a Synchro Transmitter and Receiver. (This is purely an a.c. telemetry system. This has described here because it uses land line telemetry). The theory of synchros has been explained on page 793. Fig. 27.7 shows a pair of synchro transmitter and receiver as used in position type telemetering. The rotors and stators

of the synchro transmitter-receiver pair are connected in torque transmission configuration. The input to this type of system is angular position of the synchro-transmitter. When the rotor of the torque transmitter is in the same position as that of the receiver, the emfs induced in the stator windings of both of them are equal and there is no current in the telemetering (or the transmission) channel. If the rotor of the transmitting synchro is rotated, there is an emf unbalance in the stator windings of synchro transmitter and the receiver, resulting in a current flow in the telemetering channel. This current flowing in the stator of receiver produces a torque on the receiver rotor till it occupies the same position as the rotor of the synchro transmitter.

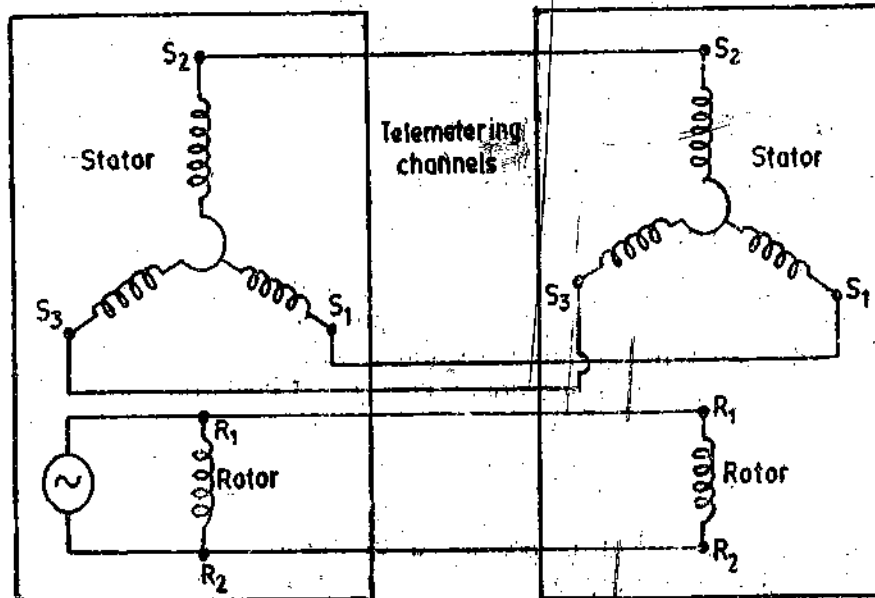

Fig. 27.7. Position telemetering system using synchros.

The indicator in such a system may be a simple pointer attached to rotor shaft of the receiver synchro for the end devices. The telemetering channel includes a connecting line and its associated terminal equipment.

27.6. A.C. Telemetry Systems

The methods described above are used for d.c. telemetering purposes, the exception being the telemetering through synchro transmitter-receiver pair. Alternating quantities can also be transmitted using telemetering circuits such as telephone cables using transformers and amplifiers. A.C. telemetry is used both for land line and radio frequency airborne telemetry techniques. Electronic means are used for a.c. telemetry.

The a.c. telemetry is used for sensors that provide an a.c. output or voltage to frequency converters. The data is available in the form of current or voltage and is modulated by an a.c. carrier produced by an oscillator.

27.7. Modulation

It is the modulation of a carrier waveform, which is usually sinusoidal, in response to the information to be carried.

A sinusoidal carrier can be described by $e_c = A_c \sin (2\pi f_c t + \theta)$... (27.1)

where A_c = amplitude of carrier, f_c = frequency of carrier ; Hz,

θ = relative phase shift of carrier ; Hz.

There are many ways of modulation of a signal. They are described below :

277.1. Amplitude Modulation (A.M.). In amplitude modulation the value of A_c changes. The carrier amplitude level swings about its unmodulated value. For a sinusoidal information signal, the expression for A_c is :

$$A_c = A_0(1 + m \cos 2\pi f_s t) \quad \dots(27'2)$$

where A_0 = amplitude of the carrier at frequency f_c when the signal or modulation at frequency f_s is zero, and f_s = signal or modulating frequency ; Hz.

$$\text{Actual amplitude of the modulation} = A_0 m \quad \dots(27'3)$$

where m = modulation index.

From. Eqns. 27'1 and 27'2, we have the modulated output :

$$e_{cm} = A_0(1 + m \cos 2\pi f_s t) \sin (2\pi f_c t) \quad \dots(27'4)$$

$$\text{Assuming } \theta = 0, e_{cm} = A_0[\sin 2\pi f_c t + \frac{1}{2}m \sin 2\pi(f_c + f_s)t + \frac{1}{2}m \sin 2\pi(f_c - f_s)t] \quad \dots(27'5)$$

The output voltage waveform has three frequencies f_c , $f_c + f_s$ and $f_c - f_s$. The two side frequencies ($f_c + f_s$) and ($f_c - f_s$) have an amplitude proportional to the message signal $A_0 m$ and are called side frequencies.

$$\text{Bandwidth BW} = (f_c + f_s) - (f_c - f_s) = 2f_s \quad \dots(27'6)$$

∴ The bandwidth is twice the frequency of the message signal.

A multiplier circuit can act as an AM modulator while an AM demodulator consists of a band pass filter, rectifier and output low-pass filter as explained on page 851. Fig. 27'8 shows an amplitude modulated signal.

The amplitude of the a.c. voltage, which carries the data to be measured, is affected by the impedance of the cable as well as the burden. Stray fields also effect the magnitude of this voltage. Hence other methods of modulation are preferred for long distance transmission.

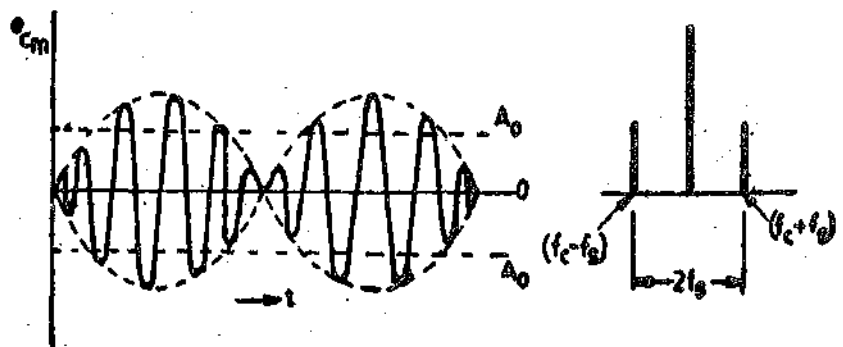

Fig. 27'8. Amplitude modulation.

277'2. Frequency Modulation (FM). In frequency modulation the instantaneous frequency of the carrier is varied in response to the amplitude of the modulating signal. The amplitude A_c and the relative phase, θ , of the carrier do not change. A schematic diagram of a frequency modulation system is shown in Fig. 27'9 (a). The frequency, f_c , of the oscillator is dependent upon the LC

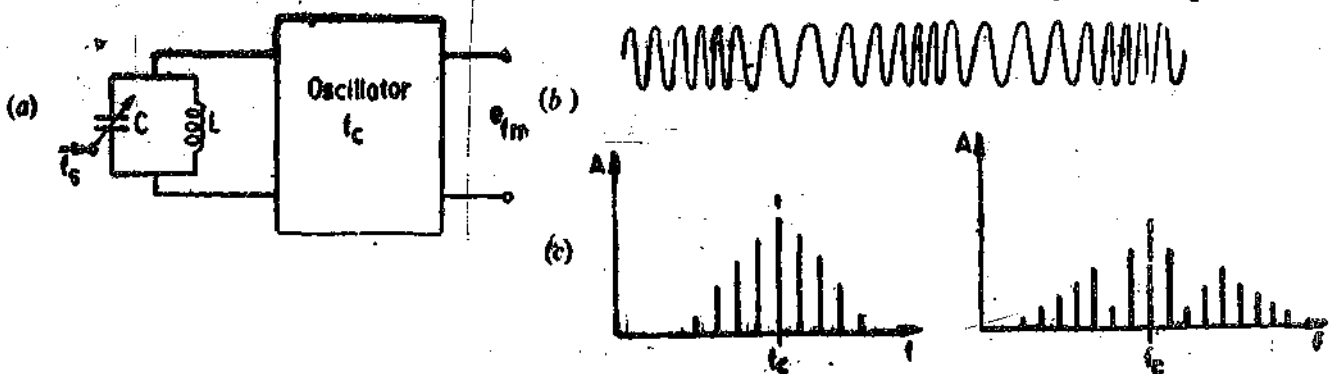

Fig. 27'9. Frequency modulation.

resonant circuit. The capacitance, C , is varied periodically with the signal or modulation frequency, f_s . Therefore, the instantaneous value of the frequency modulated signal is :

$$e_{fm} = A_c \sin(\omega_c t + m_f \sin \omega_m t) \quad \dots(27.7)$$

where m_f = modulation index.

The modulation index, m_f , is analogous to the modulation index m in amplitude-modulation systems. The frequency modulated waveform is shown in Fig. 27.9 (b).

This waveform represents a spectrum of the carrier wave and symmetrically grouped sidebands. The number and the relative amplitude of the sidebands depend not only on the signal frequency but also on the modulation index m_f . An example of a simple spectrum is shown in Fig. 27.9 (c).

The frequency components of an FM signal extend to infinity on either side of the carrier frequency. However, their amplitudes fall off rapidly outside a certain range as shown in Fig. 27.9 (b). According to Carson's rule, the approximate value of bandwidth for an FM signal is :

$$\text{Bandwidth BW} = 2(D + f_h) \quad \dots (27.8)$$

where D = maximum deviation in the carrier from its unmodulated frequency,
and f_h = highest frequency in the message signal.

Frequency modulation requires a greater bandwidth than amplitude modulation. It is used for land line and radio frequency telemetering.

The peak value of the carrier voltage must be much greater than the noise and stray emfs. With frequency modulation, the signal to be measured is much susceptible to disturbances than amplitude modulation. Frequency modulated signal can therefore be transmitted error-free over long distances.

27.7.3. Phase Modulation. The phase modulation techniques (PM) employ the use of varying the phase angle θ for telemetering purposes. The angle θ is varied about its unmodulated value and can be analyzed in a similar fashion as the frequency modulation (FM) techniques.

Three cables are used for phase modulated signals. The phase of the a.c. voltage in one conductor is changed with respect to that in the other conductor depending on the magnitude of the measured quantity. The third conductor provides the return path. The transmission frequency ranges from power frequency to about 400 Hz. Rotating field systems like synchros serve as transmitters and receivers. Angular positions are transmitted up to distances of a few kilometres using this method.

27.8. Pulse Telemetering Systems

When pulse telemetering is used, the measurement is transmitted in terms of time rather the magnitude of an electrical quantity. The information may be conveyed through land-line connections or through radio frequency links

Pulse telemetry may be classified as :

(i) Analog pulse telemetry, and (ii) Digital telemetry.

27.9. Analog Pulse Telemetry

The unknown signal is converted into a pulse train. The pulses are d.c. or a.c. voltages of constant amplitude. The width of pulses is small, or is a function of the unknown quantity (rectangular pulses). The pulses may be used to modulate a carrier in many manners described earlier. The four basic methods of analog telemetry are :

(i) Pulse amplitude modulation system, (ii) Pulse frequency method, (iii) Pulse duration modulation system, and (iv) Pulse duration phase modulation system.

27.9.1. Pulse Amplitude Modulation System (PAM). A pulse train of constant repetitive frequency is produced as shown in Fig. 27.10 using a pulse generator.

Repetitive frequency : $f = 1/T$: Hz, $\dots(27.9)$

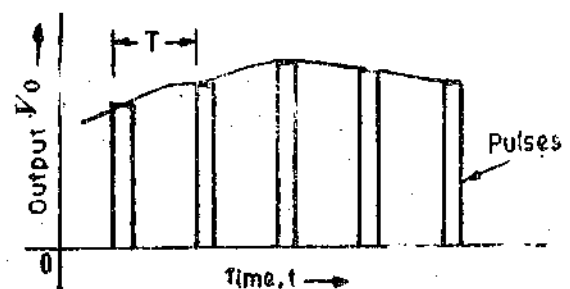

Fig. 27.10. Pulse amplitude modulation (PAM).

where T = pulse period ; s.

In fact, the carrier is modulated with pulses whose height varies proportional with the unknown signal. Therefore, amplitude of the output pulses, V_0 , varies proportionately with the unknown quantity x or

$$V_0 = K_A x \quad \dots(2710)$$

where K_A = a constant.

From the sampling theory, it is known that the frequency of the sampling pulse train must be at least twice as high as the highest order frequency component present in the unknown signal spectrum. Pulse amplitude modulation is similar in principle to amplitude modulation process.

Errors occur on account of damping of the pulse amplitude. The pulse amplitude modulation (PAM) assumes special significance in time division multiplexing systems.

2792. Pulse Frequency System. The frequency of the pulse train is :

$$f = K_f x \text{ where } K_f = \text{a constant.}$$

The time period, $T = 1/f$, and is therefore inversely proportional to the unknown quantity.

$$\text{Sum of pulses } N = \int f dt = K_f \int x dt \quad \dots(2711)$$

The pulse frequency method is shown in Fig. 2711. From Eqn. 27 11, it is clear that sum of the pulses is a measure of the time integral of the quantity being measured.

The pulses are generated using voltage to frequency technique as described in Art. 26333 on page 887. The a.c. signals generated by transducers may be directly converted in frequency with the help of Schmitt trigger circuit as described on page 689. The frequency of the pulse train lies between 0 to 10 kHz. The pulses are counted by electronic counters.

In many measurement systems the transducer output is directly in the form of pulses. Such transducers include rotating armatures, turbine meters for liquids and gases which are provided with electromagnetic or photo-electric pick-ups to provide pulse outputs for the telemetering systems.

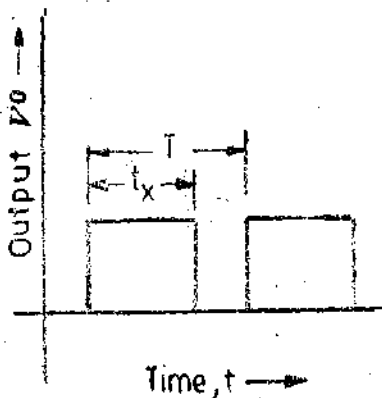

Fig. 2711. Pulse frequency method.

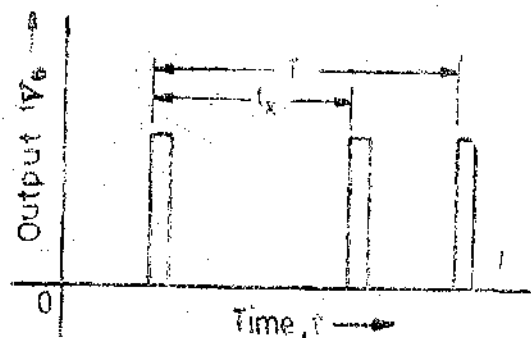

Fig. 2712. Pulse duration modulation.

2793. Pulse Duration Modulation (PDM). In pulse duration modulation systems, the magnitude of all the pulses remains constant but the duration of the pulses varies. Pulse duration systems may consist of electromechanical or electronic devices. The input may be a mechanical displacement or an electric analog signal like voltage or current. The primary measuring device may be a low torque, device such as a flow meter or a pressure gauge.

The unknown quantity, x , is converted into a rectangular pulse voltage V_0 having a duration of time t_x , where,

$$t_x = K_d x, \text{ where } K_d = \text{a constant} \quad \dots(2712)$$

This is shown in Fig. 2712. At the end of one fundamental period T , the pulse is again repeated with a possible new duration in case the unknown value x has changed in value. The

fundamental time, T , is greater than the maximum possible pulse duration-time, t_{max} . The unknown quantity x is retrieved at the receiving end by forming the ratio t_x/T . Therefore, each pulse transmits one value of unknown data. The frequency of the pulse train is below 1 Hz in case of mechanical pulse transmitters. This frequency may be upto 10 Hz if electronic transmitters are used. The transmission error is about 1%.

27.10. Pulse Position Modulation (PPM). This method is closely related to the pulse duration modulation. The unknown data x are converted into a time interval as in Eqn. 27.12. However, t_x is the time interval between two successive pulses of short duration. A rectangular pulse, is first produced by a Schmitt trigger. Two pulses of short duration as shown in Fig. 27.13 are generated from the rising and falling flanks of that pulse. At the receiving terminal, this pulse train is converted back into a pulse of duration t_x using a bistable multivibrator.

Pulse of short duration can be more easily transmitted over large distances. This is precisely the reason why PPM is preferred to PDM when the length of cable transmitter is longer.

In pulse duration modulation (PDM) systems the amplitude of all the pulses is constant, but duration of the pulses varies. In PDM one edge of the pulse is fixed in time sequence and the other edge varies in proportion to the value of information. This type of coding is called as pulse width modulation (PWM). Pulse position modulation (PPM) is similar to PDM with the exception that a short pulse is used in place of the variable pulse width. This can be obtained by differentiating and rectifying a PDM waveform. The advantage of PPM is that the same information can be transmitted with less average power with PPM than with PDM as the transmitter is ON for a shorter period with PPM. However, with PPM, the shorter pulses require a wider bandwidth for transmission.

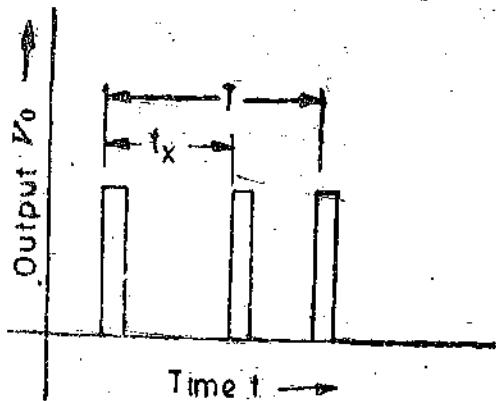

Fig. 27.13. Pulse position modulation (PPM).



Fig. 27.14. Pulse code modulation (PCM).

27.11. Digital Telemetry (Pulse-Code Modulation : PCM)

The data to be measured are quantized as explained in Art. 26.29.1 on page 816 and transmitted serially as data words in pulse code. This is the most efficient of the pulse coding systems and is called pulse code modulation, PCM, for short. It consists of sending analog information by transforming into a series of binary digits, as shown in Fig. 27.14. The analog signal is sampled at regular intervals and then each sample value is converted into a coded form. (The conversion of analog signals into digital signals is called Coding or Encoding). The process of coding introduces errors. This is illustrated by the following example.

Example 27.1. A 5 bit encoder is used. Find the number of quantization levels. Suppose each level represents 1 V, what is the range of the encoder. Find out the quantization error on account of modulation if a voltage of 27.39 is involved.

Solution. No. of quantization levels = $2^n = 2^5 = 32$

$$\text{Range of encoded} = (2^n - 1) \times 1 = (2^5 - 1) \times 1 = 31 \text{ V.}$$

Therefore the range is 0–31 V with each step representing 1V. Since the decision level is taken at 1V, the voltage involved is transmitted as 27 V in binary digits as : 11011

as $2^4 + 2^3 + 0 + 2^1 + 2^0 = 27 \text{ V}$

∴ Error on account of modulation = $27 \cdot 9 - 27 = 0 \cdot 39$ V.

From the above example it is clear that modulation introduces an additional error in the message signal. This noise may be called as quantization noise. In order to reduce quantization noise it is necessary to use a higher bit encoder.

The bandwidth of PCM signal depends upon the bandwidth of the original signal. It also depends upon the number of bits used to represent the analog signal. The receiver decodes the signal. (Decoding means conversion of digital number into an analog quantity). Thus, it is essential for the receiver to distinguish between '1' and '0' levels.

The bandwidth of the original signal extends from 0 to the highest frequency f_h Hz. The maximum sampling rate is $2 f_h$ Hz. Thus if an n digit code is used, the minimum bandwidth required is :

$$\text{Minimum bandwidth} = \frac{1}{2} \times 2f_h \times n = nf_h \text{ Hz} \quad \dots(27 \cdot 13)$$

This is because the coded pattern containing alternate 1's and 0's contains the highest frequency components and the bandwidth required to transmit the fundamental frequency of this coded pattern is half the maximum rate at which the digits are generated by pulse code modulator in order that the receiver receiving the fundamental frequency is adequate to be able to distinguish between 1's and 0's. Therefore, if an ' n ' digit code is used the bandwidth is increased n times.

The number of digits in a digital transmission can be arbitrarily increased by suitable choice of the quantizing interval. A binary number of n digits can transmit a maximum of 2^n quantum levels of the same weightage and hence enables a relative error of 2^{-n} to be achieved corresponding to a transmission error of ± 1 in the least significant figure. However no additional advantage is achieved by increasing the accuracy of the transmission much larger than the errors of the pickups of the transducers. Generally 8 to 12 digit-binary numbers are used in measurement systems. These correspond to 256 to 4096 quantization levels.

27.12. Transmission Channels and Media. The most extensively used transmission media are cables and electromagnetic radiation radio links. However, optical, ultrasonic and magnetic induction data links are also used for many applications. Land-line telemetry utilizes cables or wires to transmit data from industrial process plants and power generation stations to central monitoring and control units.

When the data is to be transmitted over lengths greater than 1 km, radio links are usually more suitable. Certain parts of the radio frequency spectrum are allocated for telemetry. The microwave links are used above about 4 MHz. Radio waves at these frequencies tend to travel in a straight line, requiring repeater stations every 30-60 km away. Radio links with airborne instrumented-flight vehicles usually use PDM-FM system.

Short range non-contact data links of approximate lengths up to 50 m, such as those used for rotating machinery and power lines generally use either FM radio, optical or ultrasonic methods. Optical links using lasers and pulse transmission are in the developmental stages. Magnetic induction finds its use in biomedical applications.

The common communication channels used for telemetering are : (i) wire line channels, (ii) microwave channels, (iii) radio channels, and (iv) power-line carrier channel.

The major difference between the channels is the range of frequencies that each channel will transmit.

27.12.1. Wire Line Channels. For Land-line telemetry wire line channels are used. The wire line is the simplest type of channel for transmission of information. The wire lines may be :

(a) privately owned or (b) leased from Posts and Telegraphs Department. In case of leased type of lines from P and T department the channels may be telegraph, teletype or telephone lines.

The lines may be aerial lines or may be cables. The line telemetering equipment is subject to the following hazards : (i) direct or induced voltages due to lightning, (ii) voltages due to unintentional contact with adjacent high voltage power circuits, and (iii) voltage induced electromagnetically or electrostatically by high voltage power circuits that run parallel to the data transmission lines.

The lines and equipment must be protected against the above mentioned undesirable effects.

Cables have advantages over the aerial lines in that :

- (i) being unexposed to lightening are more reliable,
- (ii) they have high insulation, and
- (iii) their parameters remain the same irrespective of the changes in the atmospheric conditions.

For land-line telemetry an enormous variety of connectors are employed. They range from, a pair of open wires, a pair of twisted wires, wires of a telephone cable, to co-axial cables. Non co-axial cables can be used for bandwidths upto 10 MHz over a length of a few hundred metres. The co-axial cables have a much wider range.

Cable installations are expensive and also are difficult to move, once installed, but they are more efficient and reliable.

27.12.2. Radio Channels. Where longer distances are involved, or where measurements have to be made in a missile or moving vehicle, it may be necessary to use radio frequency (RF) techniques to transmit information.

There are two major reasons for resorting to radio channels for telemetry in the case of spacecrafts, missiles or air-craft rather than record the data on board. They are :

- (i) It is many a times difficult and in some situations impossible to recover records from flights, and
- (ii) The limitations of space, weight, and operating conditions can be met more easily by telemetering the information to ground stations.

In radio frequency telemetry, multiplexing is used, as it is not possible to have many channels on account of antenna complications and due to desired saving of space, weight and power.

27.12.3. Microwave Channels. Microwave is a special case of radio transmission. The necessity for a large number of communication channels in industries like power and gas transmission and the overcrowding of spectrum in the radio frequency range has led to the increased use of microwave radio transmission. Several bands in the range of 890 MHz to 30 GHz have been allocated for microwave transmission.

The microwave frequencies are similar to television and radar in the sense that they are line-of-sight beamed directly from one antenna to other antenna and thus their use depends upon the type of terrain. The line-of-sight distance is small because of the curvature of the earth. So principle of repeated relaying is used for increasing the range of transmission with the help of intermediate receiving-transmitting stations set up every 50-80 km depending upon the terrain.

The basic cost of the transmitter and the receiver is high, but cost of additional channels is small. Hence the cost of micro wave equipment becomes competitive in case of multichannel transmission. The equipment is rugged and reliable and as mentioned above can provide a number of channels.

27.12.4. Power Line Carrier Channels. The use of power line carriers have been prevalent for a long time to transmit information between the central generating station and the local sub-stations. They utilize the power line equipment for this purpose. An a.c. carrier is coupled to the high voltage transmission line and the information to be telemetered is superposed upon the transmitted power.

Example 27.2. A data signal having frequency components from d.c. to 1 kHz is to be transmitted using a modulation method. Determine the minimum carrier channel bandwidth using the following methods of modulation.

- (a) amplitude modulation,
- (b) frequency modulation with maximum deviation in carrier frequency being 1.5 kHz,
- (c) pulse code modulation using an 8 digit code.

Solution. (a) For amplitude modulation, the minimum bandwidth of carrier channel is twice that of the data.

\therefore Minimum bandwidth of carrier channel = $2 \times 1 = 2$ kHz.

(b) For frequency modulation, the minimum bandwidth of the carrier channel is given by Carson's rule (Eqn. 27.6).

\therefore Minimum bandwidth of carrier channel = $2(D + f_h) = 2(1.5 + 1) = 5$ kHz

(c) For pulse code modulation, the minimum bandwidth of carrier channels is given by Eqn 27.13.

Minimum bandwidth of carrier channel = $nf_h = 8 \times 1 = 8$ kHz.

27.13. Multiplexing in Telemetry Systems

Multiplexing is a means of using the same transmission channel for transmitting more than one quantity. Multiplexing becomes necessary in measurement systems when the distance between transmitting and receiving point is large and many quantities are to be transmitted. If a separate channel is used for each quantity, the cost of installation, maintenance, and periodic replacement becomes prohibitively large and therefore a single channels is used which is shared by the various quantities.

Multiplexing is commonly accomplished by either time or frequency sharing of the transmission channel between the individual quantities.

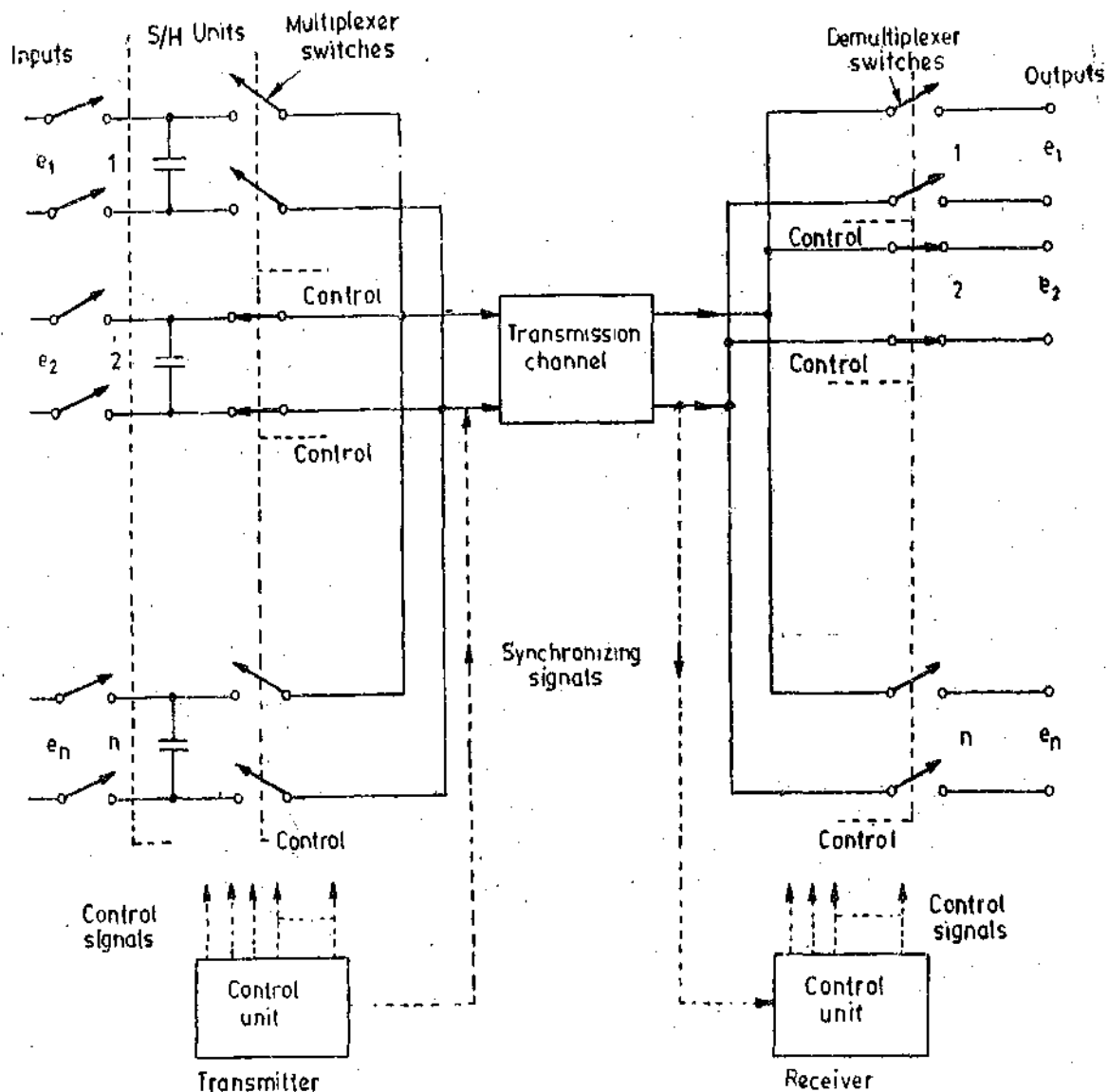

Fig. 27.15. Time Division Multiplexing.

There are two methods of multiplexing :

- (i) Time division multiplexing (TDM), and
- (ii) Frequency division multiplexing (FDM).

27.13.1. Time Division Multiplexing. In time division multiplexing the information from different measuring points is transmitted serially one after another on the same communication channel. The measurements are sampled sequentially and transmitted until all the quantities have been sampled. After this the cycle is again repeated. The time to complete transmission of all the measurements may be sufficiently small so that one quantity cannot change considerably during the interval between sampling. The order of transmission is controlled either cyclically by means of pulse generators or by command signals issued corresponding to the freely programmable requirements of the measurement system.

Multiplexers are used for switching of the measuring channels to the relevant transmission channel as shown in Fig. 27.15. The diagram shows a simple example of a system used for multiplexing of analog signals. A number of measuring points which monitor physical quantities like temperature, pressure, etc. are used as transmitters. They are shown as 1, 2, 3, ..., n . Each point is sequentially connected to its corresponding receiver. The system connects transmitter 1 to receiver 1 for a specified interval of time. Then transmitter 2 is connected to receiver 2 and so on.

In order to ensure that the rotary scanning switches do not get out of step because of power failure in the transmission channel, the two rotary switches must be synchronized. This is done by additional circuitry that stops the transmitter switch on the synchronization point until the receiver switch also is at its synchronization point.

Time Division Multiplexing involves the transmission of data samples rather than continuous data transmission which is typical of frequency division. The time division multiplexing is especially useful when telemetering slow-changing, low bandwidth data. An example of this is telemetering temperature. It is enough to transmit temperature data at a slow rate—say at an interval of 10 s. It will be extremely wasteful if the temperature measurements occupied a full radio frequency (RF) communication link. In order to increase efficiency, the communication link should be used for telemetering other process variables during the 'dead' time (i.e., the time between

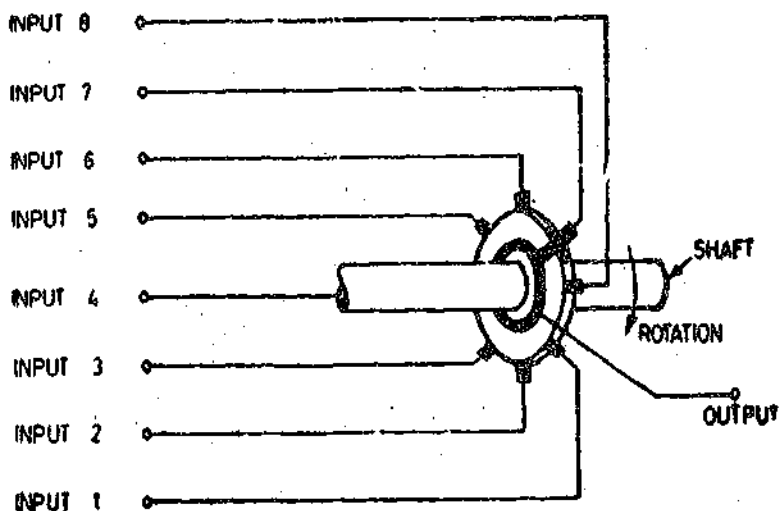

Fig. 27.16. A time-division multiplexing system using a mechanical commutator

two consecutive temperature measurements). Thus the efficient use of the communication system may be achieved by time sharing the communication channel among a number of measured parameters each being transmitted at a rate compatible with the rate of change of parameter. This time sharing simply assigns time slots for specific measurands. For example, in our case, during the time interval of 10 s a number of different data may be transmitted thereby utilizing the communication link fully. The different measurands are transmitted via a single link, one after another in a sequence, during a specified time slot. The receiving station must be capable of unscrambling the flow of incoming data and producing data lines corresponding to original measurands. It is essential to keep track of time, or identify each time slot, so that the receiving end recognises each data source.

Time Division Equipment. An example of a time-division multiplexing system is shown in Fig. 27.16. It is a commutator with only one bar which successively connects the output of the

device to one of the eight inputs. If the output of the commutator were connected to an instrumentation system, the system would read each input for a little less than $1/8$ of 1 revolution. Thus the instrumentation system shares the time of each revolution with the eight inputs. This system is limited to the revolutions per minute at which good low resistance contact on the commutator can be maintained. The system can be designed for any number of inputs.

A block diagram of an electronic time-division multiplexing system is shown in Fig. 27-17. There are eight input circuits which are successively connected to the output circuit through a diode bridge. When junction 'a' is positive with respect to junction b, the diodes in the bridge have infinite resistance, and the circuit between junctions c and d is effectively an open circuit. When junction b is positive with respect to point a, however, the diodes have very low resistance and the bridge becomes a balanced bridge circuit with very low resistance arms, and the potentials of the junctions c and d are the same. Then the voltage at c is equal to the input voltage at d, or the circuit from c to d is a closed circuit.

Now the switching circuit that controls the potential at points a and b is operated by the coincident application of a clock pulse and a reset signal at the first and second inputs, respectively, of the first AND circuit of the control system. The clock

pulse is of very short duration and has a magnitude of +15 V. During the remainder of the time, it is -15 V. The reset signal is generated by the operation of the preceding switching circuit. This reset signal is applied to the next switching circuit before the clock pulse is generated and it continues for a good part of the cycle after the clock pulse. It is +15 V during this part of the cycle and remains at -15 V during the rest of the cycle. These two pulses produce a short +15 V pulse at the output of the first AND circuit which is applied to the first input of the second AND circuit in this control system. The second input to the second AND circuit was already +15 V. These two inputs produce +15 V at the output junction e of the second AND circuit which is fed back to the first input of the second AND circuit. This locks the second AND circuit in the 1 position and keeps the output of the second AND circuit at junction e at +15 V as long as the second input to the second AND circuit is +15 V. The second input to the second AND circuit is a feedback circuit from the junction e through a time-delay circuit and a NOT circuit. The output of the time-delay circuit is also applied to the reset of the next switch to be operated. The +15 V pulse from junction e will arrive at the reset of the next switch to be operated just before the next clock pulse, and the switch will operate at the arrival of the next clock pulse. At the same time the voltage through the NOT circuit will shut off the switch that has been in operation, and the potential of point e will become -15 V and will remain at this value until the two inputs to the first AND circuit of this switch are both +15 V.

When junction e is +15 V, junction b is +15 V and junction a, which is supplied from the junction e through an inverter, is -15 V. This makes the voltage at d equal to the voltage at c, and the input voltage 1 is applied to the output of the switch. When the junction e is -15 V, the reverse

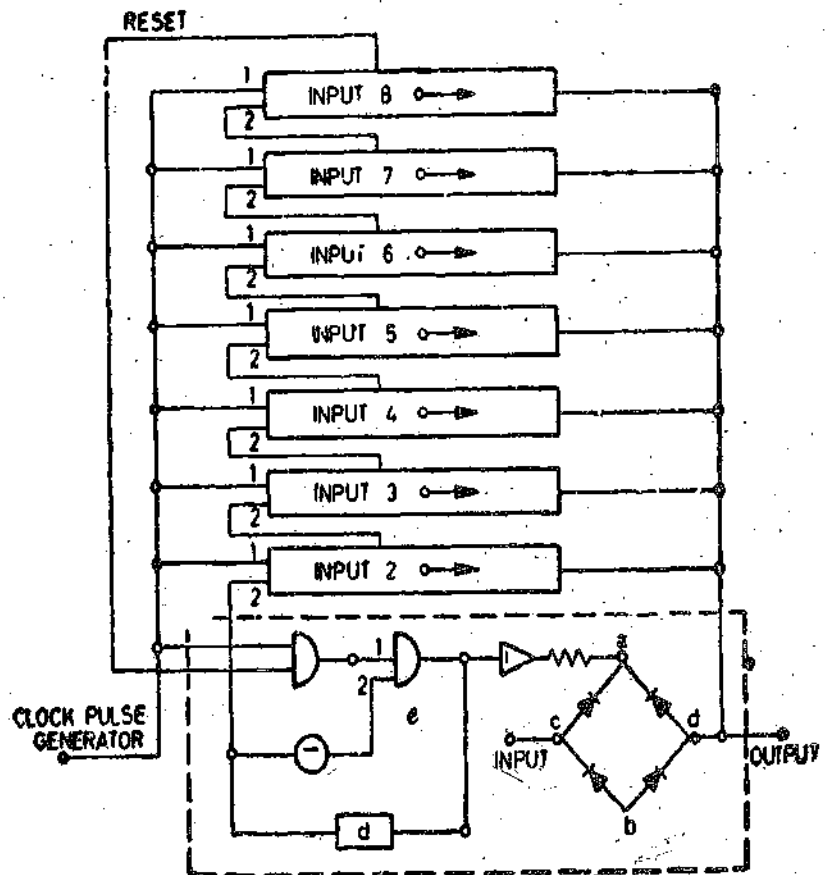

Fig. 27-17. An electronic time-division multiplexing system.

polarity is applied to junctions *a* and *b*. This opens the circuit between junctions *c* and *d*. This process continues through each of the eight switching circuits in repetitive succession at a rate determined by the clock pulse and the delay circuit. The number of inputs and switching circuits can be varied to meet the demands of the system.

Commercial circuits of this type have produced sampling rates of more than 10,000 samples per second. Thus, if 80 samples were to be sampled at 10,000 samples per second, each input would be read 125 times per second. The time between samples is 100 μ s, and each input is read at intervals of 8 ms. The limiting factor in this system is the presence of switching transients. The time required to obtain a steady-state condition after switching is near 100 μ s. Other methods of sampling have produced sampling rates of better than 1.5×10^6 samples per second.

There is one major difficulty with the time-division multiplexing system. Each input is measured at a different time, and these values are not valid for comparison or computation if there is appreciable change in the magnitude of the inputs between samples.

It may be understood that the demultiplexing equipment at the receiving end must be perfectly synchronized with the transmitting end so as to present faithful representation of the transmitted data.

Sample and Hold (S/H) System. A sample-and-hold circuit is used to overcome the above mentioned difficulty. Each signal input to the time division multiplexing system is connected to a circuit which is shown in Fig. 27-18. The first step in this procedure is to open switch S_2 , and close switch S_1 . This places an individual capacitor across each input, and the voltage across the capacitor, after a very short transient time, is equal to the input voltage. The second step is to open switch S_1 . Then the voltage across each capacitor is the respective input voltage at the instant switch S_1 was opened. The third step is to close each S_2 switch at a given signal from the time division multiplexing system to connect each capacitor of the sample-and-hold system to the readout system at the correct portion of the time-division cycle. Usually, the output of the sample-and-hold system is applied to an analog-to-

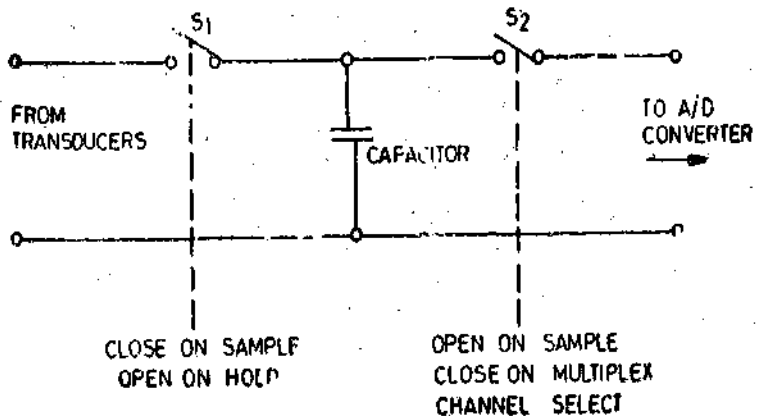

Fig. 27-18. An elementary circuit of a sample-and-hold system.

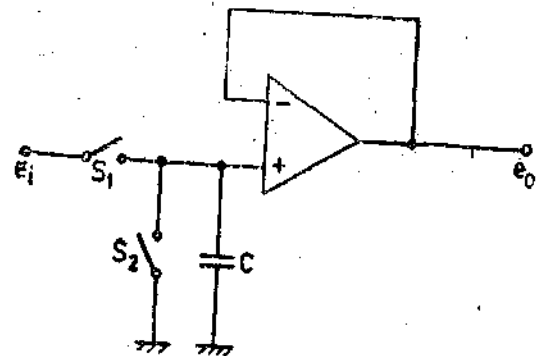

Fig. 27-19. Sample-and-hold (S/H) system using operational amplifiers.

digital converter. Then all the digital outputs during one cycle of the sample-and-hold procedure is the value of the respective inputs at the instant the switches S_1 were opened.

A Sample-and-Hold system which uses an operational amplifier is shown in Fig. 27-19. This circuit can take a very fast sample of an input voltage signal and hold this value, even though the input signal may change until another sample is required. This method uses the storing capability of a capacitor and the high input impedance of an operational amplifier.

When switch S_1 is closed, the capacitor C quickly changes to the input voltage level. Now, if switch S_1 is opened the operational amplifier acting as a voltage follower (See Art. 26-8-10 page 837) allows a measure of the capacitor voltage to be taken at the output without changing the capacitor charge. When a new sample has to be taken, switch S_2 is first closed to discharge the capacitor and

hence reset the circuit. The switches used are electronic switches and are activated by digital logic levels.

Frequency Division Multiplexing (FDM). Several information can be simultaneously transmitted using different carrier frequencies and employing modulation techniques described earlier. Each of these methods makes use of a specific frequency band for the modulation of the frequency by the signal to be measured. By suitable choice of the magnitudes of the different carrier frequencies, several data may simultaneously be transmitted over a common communication link. These can be recovered separately at the receiving end by using demodulators and filters.

A typical telemetry carrier frequency of 230 MHz may be used with a bandwidth of ± 320 kHz. This means that when used in amplitude modulation (AM), the information can be transmitted without distortion may have a bandwidth of 320 kHz. However most of the telemetry applications involve information (data) of much narrower bandwidth. For the purposes of illustration let us assume a data bandwidth of 4 kHz. Instead of directly modulating the 230 MHz carrier with the data, we can first modulate a subcarrier of say, 32 kHz. Assuming amplitude modulation (AM), this carrier will give a signal of 32 ± 4 kHz. The modulated subcarrier may now be used to modulate the 230 MHz carrier. Fig. 27-20 shows the frequency bands utilized in this transmission. The rest of the ± 320 kHz band is unused.

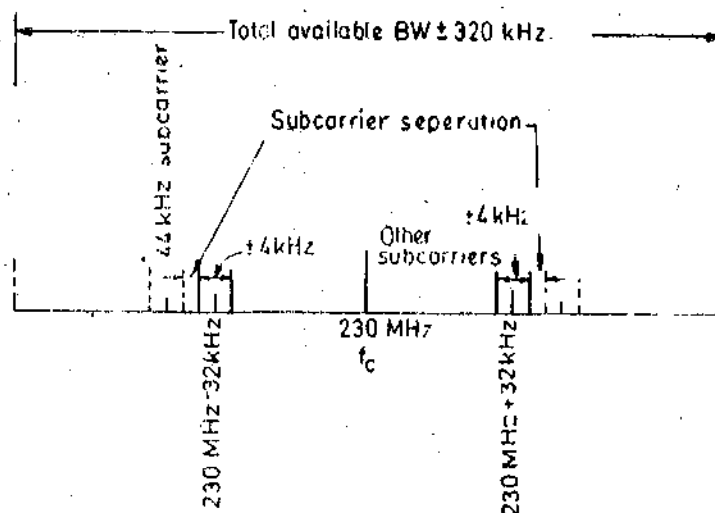

Fig. 27-20. AM sub-carriers ; Carrier 230 MHz, Subcarrier BW = ± 4 kHz.

It is then possible to modulate another sub carrier-say of 44 kHz - by another data source of similar bandwidth. Thus a 44 ± 4 kHz modulated subcarrier is obtained which is shown by dotted lines in Fig. 27-20. It is evident that we can fill the 320 kHz allowed bandwidth for a large number of subcarriers carrying data from a large number of sources.

In this example, the bandwidth of data has been taken as 4 kHz arbitrarily. It should be noted that an unused band of 4 kHz separates the modulated subcarriers. This is because 32 ± 4 kHz gives 28 to 36 kHz, and 44 ± 4 kHz gives 40 to 48 kHz. Thus there is 4 kHz separation between the highest frequency of lower subcarrier (36 kHz) and lowest frequency of the higher subcarrier (40 kHz). This separation is necessary to avoid inter-

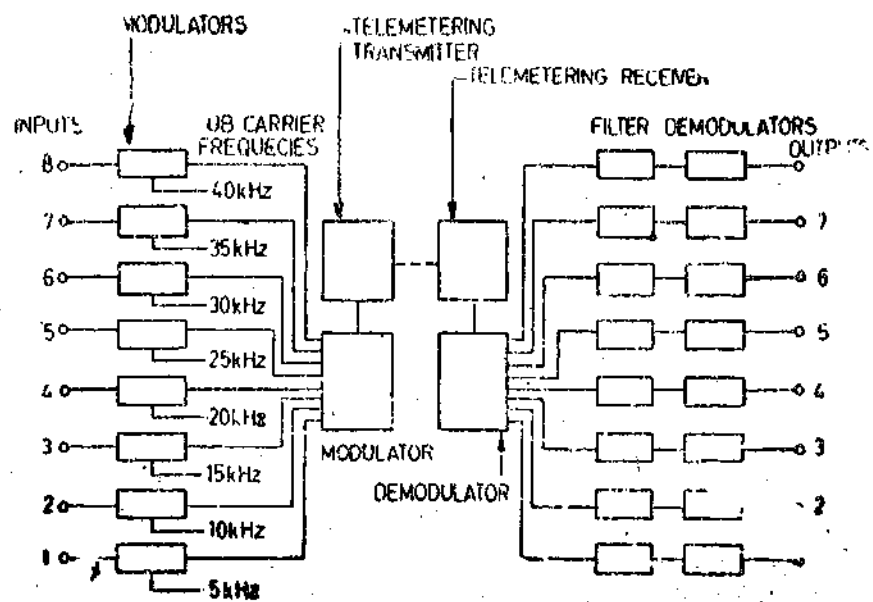

Fig. 27-21. Block diagram of an AM frequency-division multiplexing system.

channel interference and to allow separation of subcarriers at the receiving end. An improvement by a factor of 2 is obtained by using the Single Sideband (SSB) Transmission. The modulated sub-carrier signal consists 32 to 36 kHz upper sideband transmission or 28 to 32 kHz lower sideband transmission. Single sideband transmission is used wherever possible.

A block diagram of an AM frequency division multiplexing system is shown in Fig. 27.21. Each input modulates an assigned subcarrier at comparatively low frequencies (5 kHz to 40 kHz) in this case. These subcarrier frequencies are combined in a mixer. This combination modulates the main high frequency carrier. The modulated carrier is transmitted to a receiver where the main high frequency signal is demodulated. This process reproduces a combination of the subcarrier frequencies. Each of the sub-carrier frequencies is separated from the other subcarrier frequencies with the help of band-pass filters. These subcarrier frequencies are then demodulated to recover the original data. The AM frequency division multiplexing system are well-adapted to analog signals, as all inputs and output voltages are continuous whereas TDM systems have discontinuous outputs and are well suited to digital information especially when sample hold (S/H) circuits are used.

The AM-FDM system permits a number of data to be transmitted over a common channel. Similarly an FM-FDM can be used to place data on one recording channel of a magnetic tape recorder.

Examples of data usually sent by FDM systems are vibration, acceleration and dynamic strain.

Display Devices and Recorders

28.1. Introduction

The last stage of a measurement system is the data presentation stage which consists of data presentation elements. This stage consists of display devices and recorders. In order that the results of a measurement system are meaningful, they must be displayed for instant observation or for storage for observation at a later stage. The first device is called a "display device" and the second, a "recorder". The data presentation devices may be called as output devices. These output devices may not only be used as display devices indicating the output, but may be used as control devices. The control of the process is done through inverse transducers. The control aspect is not within the scope of this book and hence it is not discussed here and so are the output devices connected with such an operation. In fact, in this chapter, we are concerned with devices which represent the output of a measurement system. The devices discussed in this chapter pertain to electrical and electronic devices which display and record the output data of a measurement system.

The choice between the display devices and the recorders depends upon :

(i) The expected use of the output and (ii) The information content of the output.

The first factor concerns whether output is meant for human observation or the output is to be stored or the output is going to be an input to a digital computer. The second factor is influenced by whether a single value is desired or the output is needed as a function of time and also by the frequency content of the output.

1. Single Number Output Devices. These devices are designed to indicate the value of some particular quantity under conditions such that the value to be measured can be regarded as time invariant over the time interval during which the measurement is made. Thus a single number will represent the measurement. The time for which the single number represents a value is very short and hence readings may have to be taken after certain intervals of time. The examples of this class of devices are indicating instruments and digital display units.

2. Time Domain Output Devices. If the values of the quantity are to be taken as a function of time, the indicating instruments or the digital display units are no longer satisfactory except for applications where the output varies at a very slow rate. For fast changing outputs *i.e.* where signal waveform or shape is the desired information general purpose cathode ray tube (CRT) has to be used. In case information is to be stored over a short period of time say-up to an hour a storage type of CRT is used. However, where a permanent record of the variation of the output with time is to be kept cathode ray tube photographs, direct writing recorders, magnetic tape recorders etc. are used.

3. Machine Interpretable Output. The output devices described above provide an output that requires interpretation by human beings. In modern applications it is necessary that the output data should be in such a form that it can be "read" by a machine. These machine interpretable "outputs" can be had from (i) magnetic tapes, (ii) punched paper tape, (iii) punched cards, and (iv) pulsed signals.

The "machine interpretable output" can either be in analog form or in digital form. A signal recorded on a magnetic tape in analog form may be useful in activating output devices like CRT, a recorder or an indicating instrument.

On the other hand a signal recorded in digital format on a magnetic tape, punched paper tape or punched cards may be used as an input for output devices like digital display units, a printer or a digital computer.

28'2. Electrical Indicating Instruments

The electrical indicating instruments are used extensively for measurement of current, voltage, resistance and power. These instruments can be broadly classified as :

(i) Analog instruments, and (ii) Digital instruments.

The analog indicating instruments have already been discussed in this text. The digital indicating instruments are discussed in this chapter along with analog and digital recorders.

28'3 Digital instruments. The analog instruments display the quantity to be measured in terms of deflection of a pointer *i.e.* an analog displacement or an angle corresponding to the electrical quantity. The digital instruments indicate the value of the measurand in the form of a **decimal number**. The digital meters work on the principle of quantization. The analog quantity to be measured is first subdivided or quantized into a number of small intervals upto many decimal places. The objective of the digital instrument is then to determine in which portion of the subdivision the measurand can thus be identified as an integral multiple of the smallest unit called the quantum, chosen for subdivision. The measuring procedure thus reduces to one of counting the number of quanta present in the measurand.

The reading accuracy can be arbitrarily increased by increasing the number of decimal places *i.e.* by increasing the quantizing levels as explained in Art. 27'33 page 884. The advantages of digital instruments are given below.

28'3'1. Advantages of Digital Instruments

(i) The digital instruments indicate the readings directly in decimal numbers and therefore errors on account of human factors like errors due to parallax and approximation are eliminated.

(ii) The readings may be carried to any number of significant figures by merely positioning the decimal point.

(iii) Since the output of digital instruments is in digital form and therefore the output may be directly fed into memory devices like tape recorders, printers and digital computers etc., for storage and for future computations.

(iv) The power requirements of digital instruments are considerably smaller.

The chief advantages of analog instruments are that they are cheap and simple, and accordingly for ordinary purposes these (analog) instruments will not be completely displaced by digital instruments. However, where cost considerations and complexity of digital instruments are not of much consequence, digital instruments are certainly preferred over their analog counterparts. (At present digital instruments are very much costlier than the corresponding analog instruments but with the developments in modern techniques, the cost gap will be narrowed down). Also there are some applications where only digital instruments can be used.

28'3'2. Digital Versus Analog Instruments. When it is necessary to decide between digital and analog instruments, the choice depends upon many factors. Some of these factors are :

1. **Accuracy.** The best analog instruments are rated usually within ± 0.1 percent of full scale. Digital instruments can be made to much greater accuracies.

2. **Reaction to Environment.** Analog meter movements are relatively simple and will operate under a wide range of environments. Digital instruments are relatively complex and consist of large number of parts which individually will react to changes in temperature and humidity. However, the advantage of digital instruments is that they can be made without any moving part thus removing the errors which are caused on account of movements.

3. **Resolution** This is sometimes referred to as readability below which differences can no longer be differentiated. In analog instruments the limit is one part in several hundred. Digital instruments can be made with a resolution of one part in several thousands.

4. **Power Requirements.** Digital instruments draw only negligible power whereas the analog instruments may load the circuit under measurement and thus indicate an erroneous reading. Digital instruments have input impedances of the order of 10 M Ω or even higher.

5. Cost and Portability. Analog instruments are extremely portable and usually do not require an outside source of supply for measurements. Analog instruments are low in cost and can be moved from one location to another with ease. On the other hand digital instruments are not easily portable and require an external source of power. However, on account of modern developments in integrated circuit technology the digital instruments can be made extremely portable and low in cost.

6. Range and Polarity. Most digital instruments are essentially d.c. instruments which measure upto 100 V and upto 1000 V by means of the range attenuator. A.C. instruments use an a.c. to d.c. converter. Many digital instruments incorporate automatic polarity and range indication (Automatic Polarity Selection and Auto-ranging facilities) which reduce operator training, measurement error, and possible damage through overloads.

7. Freedom from Observational Errors. The digital instruments are free from observational errors like parallax and approximation errors. They directly indicate the quantity being measured in decimal form with the help of readout and display devices.

Analog instruments usually have a scale which is cramped at the lower end and therefore gives considerable observational errors. Also when using analog instruments inexperienced personnel often tend to select a scale that does not correspond to the setting of the range switch, thereby introducing large operating error.

Before the digital meters are described it is essential that the reader be familiarized with the working of electronic counters and the digital display devices.

28.4. Electronic Counters

Electronic counters are capable of making many measurements involving frequency, time, phase angle, radiation events and totalizing electric events.

The electronic counter normally employs a frequency divider circuit known as a scaler. A scaler produces a single pulse for every set of number of input pulses. For example, a 2 : 1 scaler produces one output pulse for 2 input pulses. A scaler is essentially a frequency divisor. The basis of counters is frequency division. This is done by a 2 : 1 scaler called a bistable multivibrator or a Flip-flop (FF) circuit.

28.4.1. RS Flip-Flop. A flip-flop is a bistable multivibrator which has an output which is either a high or a low voltage. The low voltage output is called 0 and the high voltage is called 1. Thus a flip-flop has two stable states, either 0 or 1. The output stays in its original state, either 0 or 1 unless the circuit is driven by an input called trigger. On application of trigger, the output changes its state. Thus if a trigger is applied when output is in 1 state, it changes to 0 state while if the output is in 0 state, it changes to 1 state. It should be understood that in a bistable multivibrator the output continues to be in its original state indefinitely unless triggered. Therefore it can be said that a Flip-flop has a memory. Fig. 28.1. shows an R-S flip-flop.

There are two similar transistors Q_1 and Q_2 . They are NPN type. The collector of each transistor is cross coupled to the base of the transistor. The cross coupling between collector and base results in a positive feedback.

If Q_1 is conducting there is a large voltage drop in resistance R_1 and therefore Q_1 is saturated and voltage V_{OE} at Y is only about 0.1 V. This voltage is applied to the base of transistor Q_2 and is not sufficient to turn on the transistor Q_2 , which requires a voltage of $V_{BE} = 0.7$ V (assuming that both Q_1 and Q_2 are silicon transistors). Thus transistor Q_2 is cutoff. Under these conditions output $\bar{Y} = 0$ and $Y = 1$.

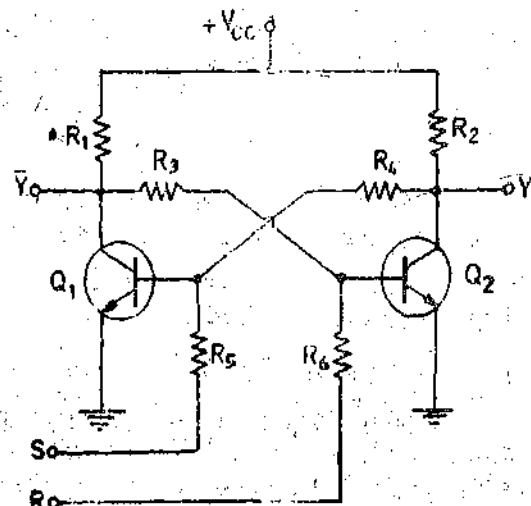

Fig. 28.1. RS Flip-Flop (Bistable Multivibrator)

Similarly if by some means we can get transistor Q_2 to conduct there will be large voltage drop across resistor R_2 and therefore the transistor Q_2 gets saturated. The potential at Y becomes 0.1 V forcing the transistor Q_1 to cutoff. Hence under these conditions $\bar{Y}=1$ and $Y=0$.

Hence there are two stable states for the flip-flop and these are:

- (i) $\bar{Y}=1$ and $Y=0$. (ii) $\bar{Y}=0$ and $Y=1$.

In order to control the flip-flop, trigger inputs are applied. If a positive going pulse is applied to the S (set) input terminal, then Q_1 conducts heavily (gets saturated) and Q_2 is cut off. Similarly, when a positive going pulse is applied to R (reset) input terminal Q_2 gets saturated and Q_1 is cut off.

Thus application of a positive going pulse to S input terminal is called Setting the flip-flop and result in a binary output where $Y=1$ and $\bar{Y}=0$.

Application of a positive going pulse to the R input terminal is called Resetting of the flip-flop and results in a binary output where $Y=0$ and $\bar{Y}=1$.

The truth table for an RS flip-flop is:

R	S	Y
0	0	Last value
0	1	1
1	0	0

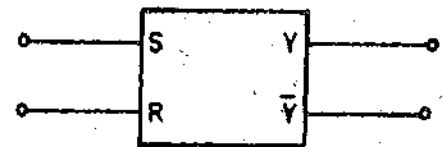

Fig. 28'2. Logic symbol for RS flip-flop.

The input condition $R=1$ and $S=1$ is forbidden as it means that we are trying to get $Y=1$ and $Y=0$ simultaneously which makes no sense. The logic symbol for a RS flip flop is shown in Fig. 28'2.

28'4'2. T and RST Flip-Flops. Fig. 28'3 shows a Toggle (T) flip-flop. A train of narrow pulses is applied to the T input terminal. This circuit uses two And gates and a RS flip-flop. Every time a pulse is applied, the output of the flip-flop changes state.

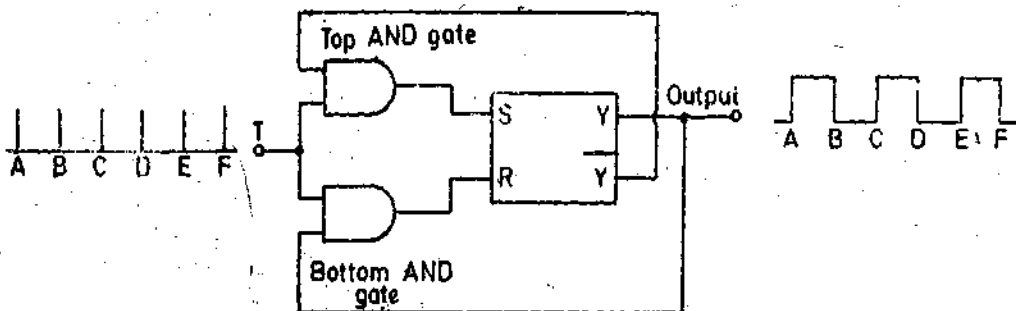

Fig. 28'3. T flip-flop.

Suppose $Y=0$ and $\bar{Y}=1$ just before the pulse A is applied to terminal T . On application of this pulse, the inputs to the top and gate are 1 and 1 and therefore the top gate is enabled (opened).

A pulse is applied to terminal S . On the other hand the two inputs to bottom AND gate are 1 and 0 and is thus disabled (closed) and no input is applied to terminal R .

Hence the flip-flop is set or $Y=1$ and $\bar{Y}=0$

When the next pulse B is applied to terminal T , the input to the top gate is 1 and 0 (since $\bar{Y}=0$) and hence it is disabled. Therefore no pulse is applied to terminal S . On the other hand the bottom AND gate is enabled as the two inputs to it are 1 and 1 as $Y=1$ and therefore a pulse is applied to terminal R . This resets the flip-flop resulting in $Y=0$ and $\bar{Y}=1$

Thus each incoming positive pulse is alternately steered into the set and reset inputs, and hence the flip-flop toggles *i.e.* alternately sets and resets producing 1 or 0 states at the output. Therefore two input pulses produce one output pulse. This means that the frequency of the output is half of that of the input. Thus a *T* flip-flop acts as a frequency divisor which divides the input frequency by two.

We have till now considered flip-flops which respond to positive going pulses. However, many a designs are possible for a *T* flip-flop. For example it is possible to build a *T* flip-flop that responds to a negative going pulse. Hence, onwards we will discuss *T* flip-flops which respond to negative edge of a square wave. Fig. 28'4 shows a *T* flip-flop. This flip-flop changes its state only on the negative edge of the input signal.



Fig. 28'4. T flip-flop.



Fig. 28'5. RST flip-flop.

A RST flip-flop combines an RS flip-flop and a *T* flip-flop. It can set, reset or toggle. The most important flip-flop is the one which sets or resets to positive going *R* and *S* inputs and toggles for negative going inputs. The symbol for an RST flip-flop is shown in Fig. 28'5.

Thus, summarizing :

Input	Sets/Resets/Toggles	Final State
+ve going applied to <i>S</i>	Sets	$Y=1, \bar{Y}=0$
+ve going applied to <i>R</i>	Resets	$Y=0, \bar{Y}=1$
-ve going applied to <i>T</i>	Toggles	switches from 1 to 0 and 0 to 1

28'4'3. Decade Counter. Four flip-flops can be in cascade to act as counters for the input pulses. A decade counter uses four RST flip-flops *A, B, C, D*. Fig. 28'6 shows four RST flip-flop in cascade.

A square wave is input to the counters. This square wave is called a "clock". The output from flip-flop *A* drives the flip-flop *B*. The output of flip-flop *B* drives flip-flop *C* which in turn drives flip-flop *D*.

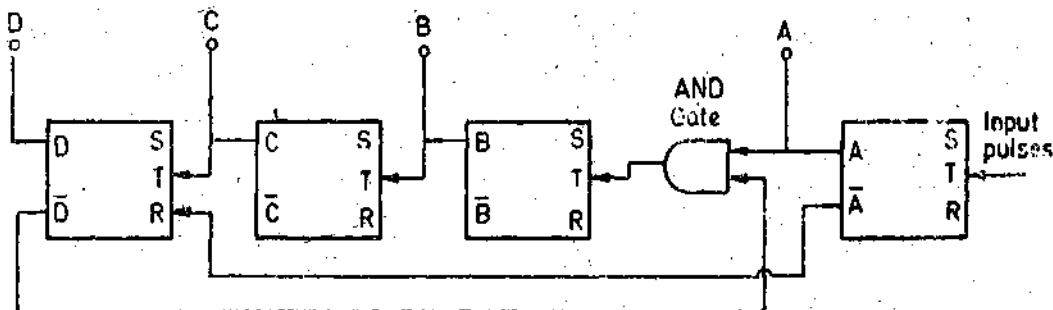

Fig. 28'6. A decade counter.

To start the operation, all the flip-flops, are reset and therefore the states of the four RS flip-flops are ;

$$D C B A = 0 0 0 0 \text{ and } \bar{D} \bar{C} \bar{B} \bar{A} = 1 1 1 1$$

When the first clock pulse is applied to T input terminal of RS flip-flop A , it changes its state on the negative going edge of the pulse. Thus at the end of the first pulse the state of the flip-flop is :

$$D C B A = 0 0 0 1 \text{ and } \bar{D} \bar{C} \bar{B} \bar{A} = 1 1 1 0$$

The two inputs to the AND gate are A and \bar{D} and both are 1 state. Therefore the AND gate is enabled (opened). A positive going pulse is applied to the T terminal of B flip-flop and therefore it does not change its state. It remains at 0 state and so do C and D flip-flops. On the application of 2nd pulse, A goes from 1 to 0. Since the AND gate is open, a negative going pulse is applied to B flip-flop. This changes the state of flip-flop B . It changes from 0 to 1. Therefore a positive going pulse is applied to flip-flop C and it remains in its original state and so does flip-flop D .

The states at the end of 2nd pulse are :

$$D C B A = 0 0 1 0 \text{ and } \bar{D} \bar{C} \bar{B} \bar{A} = 1 1 0 1$$

This disables (closes) the AND gate since $A=0$ and $\bar{D}=1$.

On application of the third pulse, flip-flop A changes its state from 0 to 1. Since the AND gate is closed no pulses are applied to flip-flops B , C and D and their states remain unchanged.

Thus at the end of third pulse, the states are :

$$D C B A = 0 0 1 1 \text{ and } \bar{D} \bar{C} \bar{B} \bar{A} = 1 1 0 0$$

Since the inputs to AND gate A and \bar{D} are both 1, it is enabled or the gate is open now. On the application of the 4th pulse, A goes from 1 to 0 and therefore a negative going pulse is applied to B . Flip-flop B changes its state and it goes from 1 to 0. Thus a negative going pulse is applied to flip-flop C and its state changes from 0 to 1. The change of state of flip-flop C is applied to flip-flop D . Since flip-flop C changes its state from 0 to 1, a positive going pulse is applied to flip-flop D and therefore it does not change its state. At the end of 4th pulse, the states of flip-flops are :

$$D C B A = 0 1 0 0 \text{ and } \bar{D} \bar{C} \bar{B} \bar{A} = 1 0 1 1$$

The AND gate is disabled (closed). On the application of 5th pulse, flip-flop A changes its state from 0 to 1. Since the AND gate is closed no pulses is applied to flip-flops A , B , C , D and they therefore remain in their original state.

Thus at the end of 5th pulse the states of the flip-flops are :

$$D C B A = 0 1 0 1 \text{ and } \bar{D} \bar{C} \bar{B} \bar{A} = 1 0 1 0$$

This means that the AND gate is enabled (open) again on the application of 6th pulse Flip-flop A changes its state from 1 to 0. Since the AND gate is open its output is applied to flip-flop B which does not change its state and so do flip-flops C and D . Therefore at the end of 6th pulse, the states of flip-flops are :

$$D C B A = 0 1 1 0 \text{ and } \bar{D} \bar{C} \bar{B} \bar{A} = 1 0 0 1$$

The AND gate is closed as $A=0$ and $\bar{D}=1$

On the application of 7th pulse, flip-flop A changes its state from 0 to 1. As the AND gate is closed and therefore flip-flops B , C and D remain in their original state. Hence, at the end of the 7th the pulse states of flip-flops are :

$$D C B A = 0 1 1 1 \text{ and } \bar{D} \bar{C} \bar{B} \bar{A} = 1 0 0 0$$

The AND gate is open now as $A=1$ and $\bar{D}=1$. On application of 8th pulse, flip-flop A goes from 1 to 0. This applies a negative going pulse to flip-flop B which goes from 1 to 0.

The output from flip-flop *B* is applied to flip-flop *C* which also receives a negative going pulse and therefore it goes from 1 to 0. So a negative going pulse is applied to flip-flop *D* changing its state from 0 to 1. The states at the end of 8th pulse are :

$$D C B A = 1 0 0 0 \text{ and } \bar{D} \bar{C} \bar{B} \bar{A} = 0 1 1 1$$

Since the inputs to the AND gate are $A=0$ and $\bar{D}=0$, it is closed.

On the application of 9th pulse, flip-flop *A* changes its state from 0 to 1. Since the AND is closed ; the other three flip-flops *D, C, B* remain in their original state. Hence at the end of 9th pulse, the states are :

$$D C B A = 1 0 0 1 \text{ and } \bar{D} \bar{C} \bar{B} \bar{A} = 0 1 1 0$$

The AND gate is closed as $A=1$ and $\bar{D}=0$.

On application of 10th pulse, *A* changes its state from 1 to 0. Since the gate is closed no pulse is applied to flip-flops *B* or *C* and they remain in their original state. *A* changes from 0 to 1. This positive pulse is applied to *R* terminal of flip-flop *D* which resets itself. It was in 1 state and therefore comes to 0 state

Thus at the end of 10th pulse, the states are :

$$D B C A = 0 0 0 0 \text{ and } \bar{D} \bar{B} \bar{C} \bar{A} = 1 1 1 1$$

The counting now can start all over again.

Thus we get one output pulse for ten input pulses.

Hence a decade counter acts as a decade frequency divider since it divides the frequency by 10 and therefore it is called a decade dividing assembly (DDA).

28'5. Digital Display Methods. In digital instruments, output device indicate the value of measured quantity in decimal digits. This is done by using a Digital display device. A digital display device may receive digital information in any form but it converts that information to decimal form. Thus the display device indicates the value directly in decimal digits. The number of digits correspond to the significant figures needed to represent the value. The basic element in a digital display device is the display for a single digit because a multiple digit display is nothing else but a group of single digit displays. Fig. 28'7 shows a multiple digit display consisting of 4 single digit displays.



Fig. 28'7. Multiple digit display.

A single digit display is capable of indicating the numbers from 0 to 9. There is also usually provision for a decimal point between each of the numerals. One of these is selected and activated in accordance with the range selection controls of the instrument. Some instruments have automatic range selection, commonly called **autoranging**. The input to the digit display is a code indicating the particular number to be displayed, or the excitation of one of the ten inputs designating the number to be displayed.

A typical binary code on four input lines is given in Appendix A. The digit displayed will depend on which combination of excitation or non-excitation is present, 0 indicates non-excitation while 1 indicates excitation. It should be understood that the signal should be decoded and decoding circuits are a part of the display units.

28'6. Digital Display Units

There are many ways of classifying digital display units. One of the methods of classifying them is based upon the format used. The display can be **planar** i.e. the entire read-out characters are in the same plane or **non planar** where the characters are displayed in different planes.

The planar displays may be illuminated **segmental type**, illuminated **dot matrix type**, displays

using rear projection and gaseous discharge type segmental displays. The non-planar displays include gaseous discharge tubes like nixies and displays using illuminated lucite sheets.

28'7. Segmental Displays

The segmental displays may be either 7 or 14 segmental ones depending upon whether numeric or alphanumeric displays are required.

Seven Segmental Display. Fig. 28'8 shows a seven segmental display. This is used for numeric display. It consists of seven segments *a, b, c, d, e, f* and *g*. A segmental display forms the digit to be displayed by illuminating proper segments from the group.

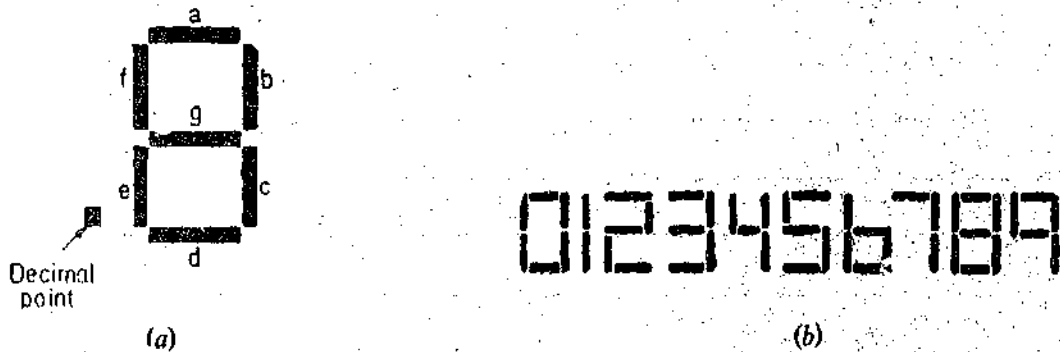

Fig. 28'8. Seven segmental display.

By illuminating the proper combination of these 7 segments numbers 0 through 9 can be displayed. The display is incandescent and operates on low voltages (12-48 V) and requires about 10 to 50 mA current when using LEDs (Light emitting diodes). LCDs (Liquid crystal diodes) are also used for segmental displays.

28'7'2. Fourteen Segmental Display. For display of Alphanumeric Characters (both numerals as well as alphabets) a 14 segmental display unit shown in Fig. 28'9 is used.

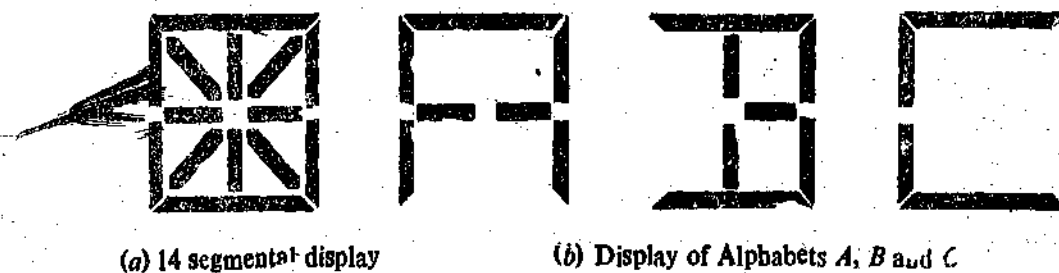

Fig. 28'9. Fourteen segmental display and formation of alphabets.

The diagram shows how alphabets *A, B* and *C* are displayed by illumination of proper segments.

28'8. Dot Matrices. Dot matrices may be used for display of numeric and alphanumeric characters.

28'8'1. A 3 × 5 Dot Matrix. A 3 × 5 dot matrix as shown in Fig. 28'10 may be used for display of numeric characters.

28'8'2. Dot Matrix Utilizing 27 Dots. Another system using 27 dots is shown in Fig. 28'11. This system displays the numeric characters as shown in the diagram.

The dots may be square or round with 0.4 mm side or diameter. LEDs and LCDs are used for display (illumination) of dots.

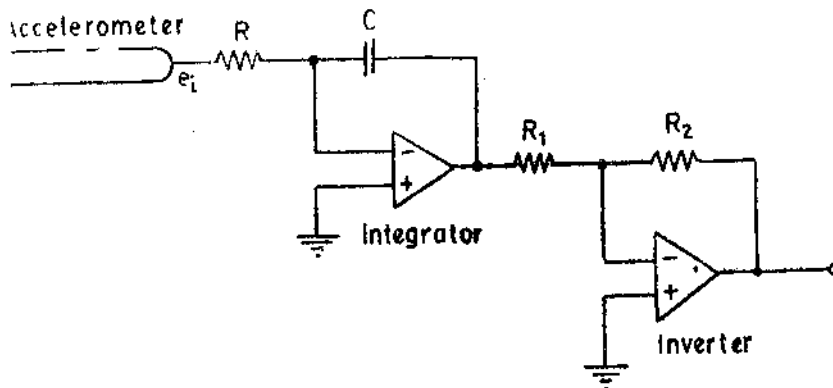

Fig. 29.55. An integrator and an inverter used for obtaining velocity information for accelerometer.

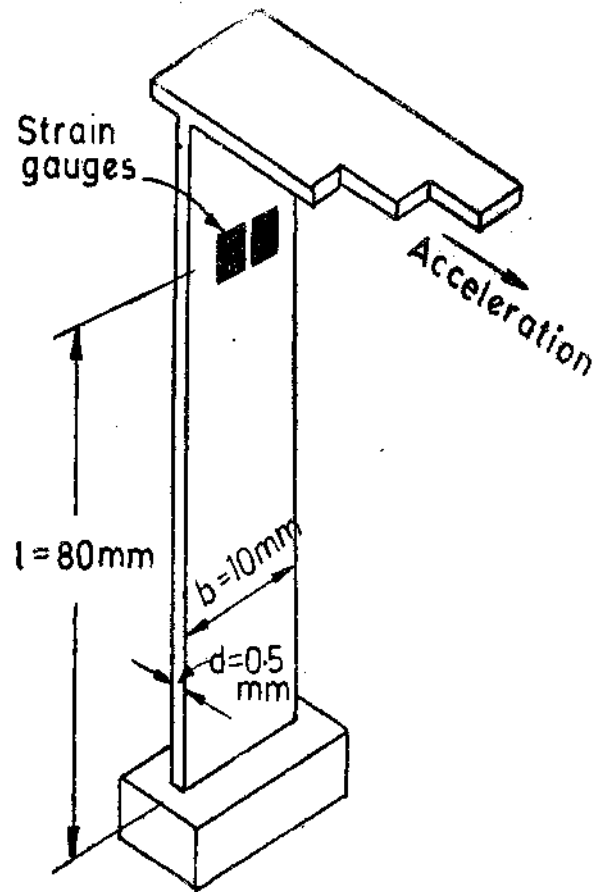

Fig. 29.56

Example 29.29. An accelerometer shown in Fig. 29.56 consists of mass weight 0.5 N attached to a spring cantilever. The spring is made up of a material of modulus of elasticity 200 GN/m² and is of uniform rectangular cross section. The output is obtained from a strain gauge bridge comprising four active strain gauges of gauge factor 2. Two strain gauges are mounted on each side of the cantilever. The gauges are connected in a bridge circuit with input voltage of 3 V d.c. Find the bridge output voltage at open circuit for a horizontal acceleration of 4 g. The stress is given by $s = 6 Fl/bd^2$ N/m²

Solution. Force $F = m \times a = \frac{0.5}{g} \times 4g = 2$ N.

Stress $s = 6 Fl/bd^2 = 6 \times 2 \times 80 \times 10^{-3} / (10 \times 10^{-3}) \times (0.5 \times 10^{-3})^2 = 384 \times 10^6$ N/m² = 384 MN/m².

Strain $\epsilon = \frac{s}{E} = \frac{384 \times 10^6}{200 \times 10^9} = 1.92 \times 10^{-3}$.

Relative change in resistance of gauge = $\Delta R/R = G_f \epsilon = 2 \times 1.92 \times 10^{-3} = 3.84 \times 10^{-3} \Omega$.

Open circuit voltage of a bridge using 4 active strain gauges is :

$e_0 = \frac{\Delta R}{R} e_i = 3.84 \times 10^{-3} \times 3 \text{ V} = 11.52 \text{ mV}$.

MEASUREMENT OF TEMPERATURE

29.35. Temperature Measuring Devices

The following devices are used for the measurement of temperature :

1. Resistance thermometers,
2. Semiconductor thermometers.

3. Thermistors,

4. Thermocouples, and

5. Radiation pyrometers.

29.36. Electrical Resistance Thermometer

The principle of electrical resistance thermometers has already been explained in Art. 25.21 page 773. The resistance of metals changes with change in temperature. The resistance thermometer uses the change in electrical resistance of a metallic conductor to determine the temperature. The requirements of a conductor material to be used in resistance thermometers are :

(i) the change in resistance of the material per °C should be as large as possible, and

(ii) the resistance of the material should have a continuous and stable relationship with temperature. Metals used in resistance thermometers are listed in Table 29.1.

TABLE 29.1

Metals Used for Resistance Thermometers

Material	Temperature co-efficient per °C (Percent)	Range °C		Melting point °C
		Min.	Max.	
Platinum	0.39	-260	1100	1773
Copper	0.39	0	180	1083
Nickel	0.62	-220	300	1455
Tungsten	0.45	-200	1000	3370

The resistance temperature characteristics of nickel, copper and platinum are shown in Fig. 25.30 on page 774.

29.36.1 Platinum Resistance Thermometer

The most commonly used material for metallic resistance thermometer is platinum. The resistance temperature characteristics of pure platinum are very well defined and show a high degree of repeatability. Therefore, these resistance thermometer elements are used over a wide range to establish the International temperature scale.

Resistance type temperature bulbs use sensing elements in the form of wires or foil. The films deposited on insulating surfaces are also used for temperature sensing. In the wire type, the arrangement is commonly a helical coil wound as a double wire to avoid inductive effects. The laboratory type resistance thermometers have the temperature sensing element wound on a cross mica former and enclosed in a Pyrex tube as shown in Fig. 29.57 (a). The tube may be evacuated or filled with inert gas to protect the platinum.

The industrial type of thermometer is shown in Fig. 29.57 (b) the former being of grooved ceramic and the wire being protected by a glass coating or by a stainless steel tube. The element is normally sealed in glass when used for temperatures upto 150 °C and ceramic for use in temperatures up to 850 °C. This sealing has the two-fold advantage of providing structural strength and protection from chemical attack. Resistance thermometers are sometimes used above 850 °C but they have a limited life.

Resistance elements are also available as thin etched grids of metal foil similar in shape to strain gauges. They are constructed of platinum and may be bonded to a plastic backing.

for attachment to a surface. They may be open-faced or coated and have a fast response compared with bulb type thermometers. Thin film sensors have an extremely fast response and they are extensively used in aero-space industry.

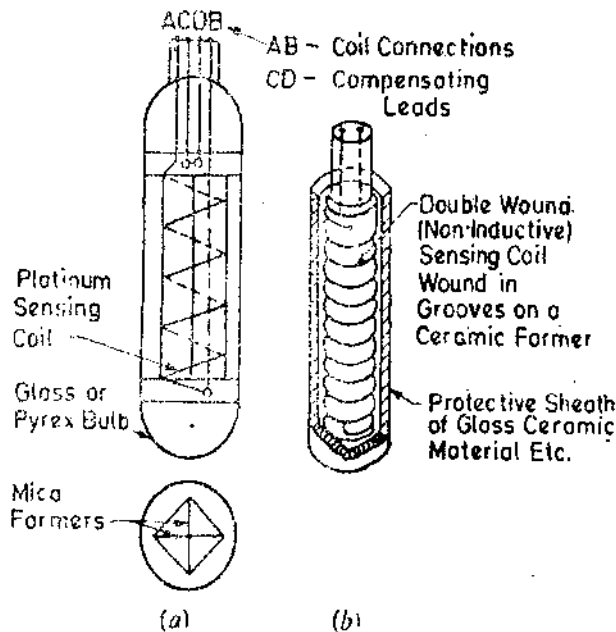

Fig. 29.57 Resistance thermometer.

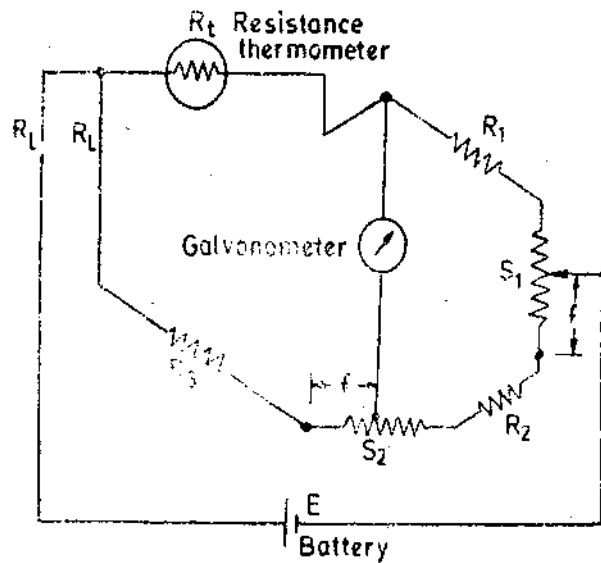

Fig. 29.58. Measurement of temperature with double slide wire bridge and resistance thermometer.

29.36.2. Measurement of Resistance of Thermometers

The measurement of change of resistance of the thermometer due to temperature changes is measured by Wheatstone bridge. Ordinary Wheatstone bridge is not used for measurement of changes in resistance as it has many disadvantages as explained below :

- (i) The contact resistance of the adjustable standard resistor may be large enough to produce an error when measuring the change in resistance of thermometer.
- (ii) The leads from the thermometer to the bridge may introduce an error due to change of their resistance produced by temperature changes.
- (iii) The current through the thermometer produces a heating effect equal to the product of the current squared and the resistance of thermometer.

Slight modification of the Wheatstone bridge, such as a double slide wire bridge, eliminate most of these problems

A double slide wire bridge is shown in Fig. 29.58. It has two slide wire resistors S_1 and S_2 which are tied together so that the fraction of S_1 in series with the resistance R_2 is equal to the fraction of S_2 in series with resistance R_3 . This fraction is defined as f .

There are three equal leads from the thermometers to the bridge. The resistance of each lead is R_L .

$$\therefore \text{At balance we have : } \frac{R_t + R_L}{fS_2 + R_3 + R_L} = \frac{R_1 + S_1 - fS_1}{fS_1 + R_2 + S_2 - fS_2}$$

If the right hand side of the above expression is unity, the resistance of thermometer element is $R_t = fS_2 + R_3$.

$$\text{This condition is obtained when : } R_1 + S_1 - fS_1 = fS_1 + R_2 + S_2 - fS_2$$

$$\text{This is an identity when : } R_1 - R_2 = S_1 = 0.5 S_2$$

The bridge is designed using these values.

Since there are three leads coming out of the resistance thermometers, the method is known as three lead method.

Four Lead Method. In applications, where the highest degree of accuracy is required, the **four lead method** is used. Such a system is used with a platinum resistance thermometer employed as a laboratory standard for calibration purposes. In this method, two circuit arrangements are used. They are shown in Figs 29'59 (a) and (b). In fact, both the arrangements are required for measurement purposes. First a measurement is made using circuit of Fig. 29'59 (a) and then a second reading is taken by using circuit of Fig. 29'59 (b). The average of the two readings is taken to give the correct result.

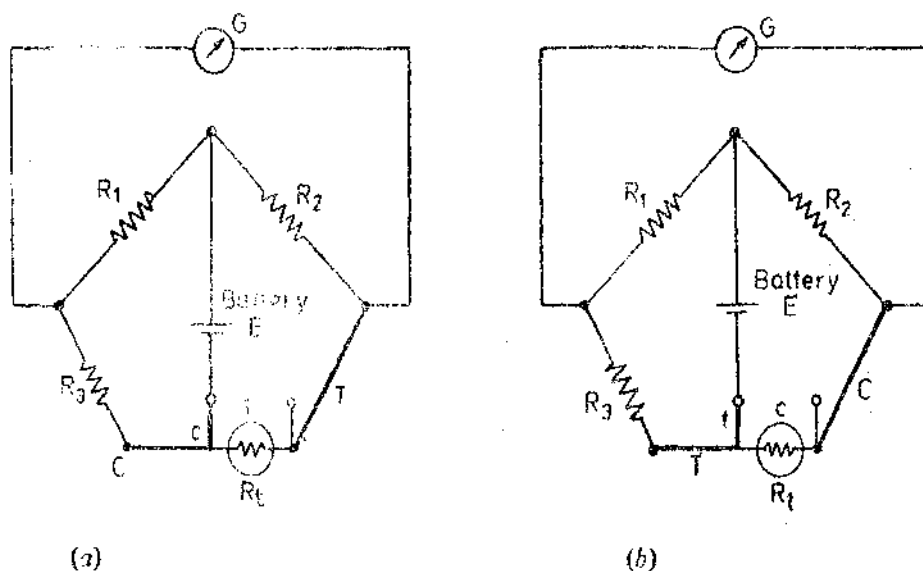

Fig. 29'59. Four lead method for connection of resistance thermometer.

For circuit of Fig. 29'59 (a), we have : $R_a + C = R + T$... (i)

For circuit of Fig. 29'59 (b), we have : $R_b + T = R + C$... (ii)

∴ From (i) and (ii) we get : $R_t = \frac{R_a + R_b}{2}$

It is evident that this method should be used only when accuracy of the highest order is desired since the method is both time consuming and inconvenient.

It should be noted that two separate leads are connected directly to each end of the resistance winding. The a, b, c leads C and c on one side and T and t on the other side.

29'36'3. Salient Features of Resistance Wire Thermometers

1. Resistance wire thermometers have a high degree of accuracy. Precision laboratory instruments may be calibrated for measuring temperatures to within $\pm 0.01^\circ\text{C}$. Industrial instruments called "resistance temperature detectors (RTD)" can be calibrated to detect the actual temperatures to within $\pm 0.25^\circ\text{C}$ up to 120°C , and $\pm 0.5^\circ\text{C}$ from 120°C to 550°C .

2. Resistance thermometers are normally designed for fast response, as well as accuracy to provide close control of processes in which narrow ranges or small temperature spans must be maintained.

3. Each type of resistance thermometer is interchangeable in a process without compensation or recalibration, because each type is calibrated with reference to a standard resistance-temperature curve. If a unit is damaged it can be easily replaced.

4. Typical industrial applications of resistance thermometers for measuring temperature are cooling processes, heating ovens, drying ovens, kilns, process vessels, baths, quenchers, refining, controlled storage plants, steam and power generation condensates, steam exhausts, pickling and plating plants, injection moulding, compression moulding, transfer moulding, and air inversion measurements.

29'37. Semi-conductor Thermometers

Semi-conductor materials like germanium crystals with controlled doping can be used for measurement of cryogenic temperatures especially below 25 K (-248°C). They are also usable at 100 K (-173°C). Semi-conductor materials used in resistance temperature thermometers have large resistance temperature co-efficients and hence they are very sensitive in the above mentioned range. They are repeatable within 0.01°C , but the units must be individually calibrated.

Silicon crystals are now being used in the range -48°C to 252°C . In this range, their resistance increases with increasing temperature, and the relationship is sufficiently linear. These thermometers must be individually calibrated.

Carbon resistors like those commonly used in electronic circuits are also used as temperature sensitive elements.

The advantages are :

- (i) They are readily available and are inexpensive. (ii) They are rugged and sensitive.
- (iii) Their sizes are small. Common sizes vary from 0.25 to 1 watt power and 10 to 500 Ω resistance.
- iv) They have a good frequency response characteristics.

Their disadvantages are :

- (i) They are not so reproducible as germanium.
- (ii) They have a large negative resistance temperature co-efficient below -213°C .

29'38. Thermistors

The principle of working and constructional details of thermistors have already been explained in Art. 25'22 on page 777.

29'38'1. Characteristics of Thermistors

1. **Resistance Temperature Characteristics.** The mathematical relationship between the resistance of a thermistor and absolute temperature is given by :

$$R_{T_1} = R_{T_2} \exp [\beta(1/T_1 - 1/T_2)] \text{ (See Eqn. 25'36 page 778).}$$

The resistance temperature characteristics of a thermistor are drawn in Fig. 25'24 on page 778. The characteristics show that even for a small change in temperature the change in resistance of the thermistor is very large. Thus thermistors have a high sensitivity and are extremely useful as resistance temperature detectors.

2. **Voltage Current Characteristics.** The voltage-current characteristics (Fig. 29'60) of a thermistor are important. If the applied voltage to a thermistor is small, the current is small and the device obeys Ohm's law. Thus at low voltages current is proportional to voltage. However, when the current in the thermistor is large enough to raise the temperature of the thermistor appreciably above the ambient temperature, the resistance of the thermistor will be decreased and more current will flow, further increasing the temperature and decreasing the resistance of the thermistor. This current increases until the heat dissipation of the thermistor equals the electrical power supplied to the thermistor. The characteristics are shown in Fig. 29'60. The log of voltage is plotted as a function of log of the current, while the power and resistance are read from the diagonal log scales. The current increases with increase in voltage until a maximum voltage is reached. Beyond this the current increases with decrease in voltage and the thermistor has a negative resistance.

Hence under any fixed ambient conditions the resistance of a thermistor is largely a function of power being dissipated within itself, provided there is enough power available to raise its temperature of ambient. Under such operating conditions, the temperature above thermistor may rise 100°C to 200°C and its resistance may drop to one thousandth of its value at low current.

This characteristic of self heat of a thermistor provides an entirely new field of uses of thermistors. In the self heat state, the thermistor is sensitive to anything that changes rate at which heat is conducted away from it. Thus it can be used to measure flow, pressure, liquid level, composition of gases etc. If on the other hand, the rate of heat removal is fixed, then the thermistor is sensitive to power input and can be used for power level or voltage control.

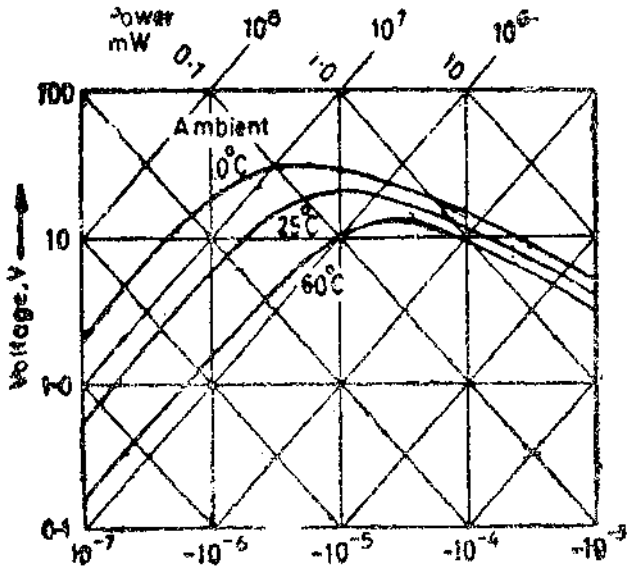

Fig 29'60. Voltage-current characteristics of a thermistor.

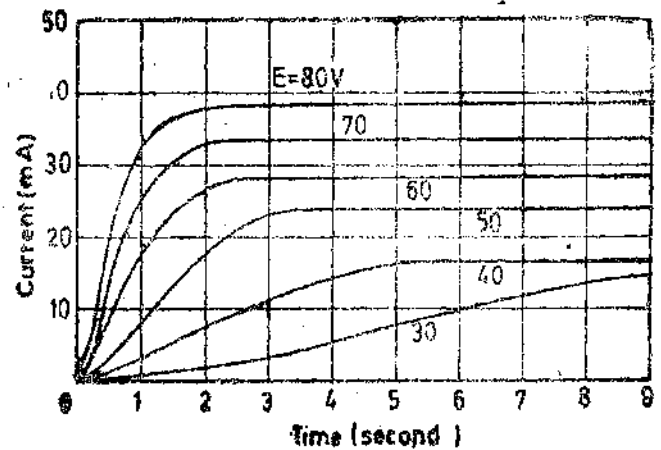

Fig. 29'61. Current-time characteristic of a thermistor.

3. Current-Time Characteristics. The current time characteristics of Fig. 29'61 indicate the time delay to reach maximum current as a function of applied voltage. When the self heating effect occurs in a thermistor network, a certain finite time is required for the thermistor to heat and the current to build up to a maximum steady value. This time may be changed by changing the applied voltage or the series resistance of the circuit. This time-current relationship provides a simple and accurate means of providing time delays ranging from micro seconds to minutes. Thus a thermistor may be used for providing time delays.

29'38'2. Measurement of Temperature with Thermistors

The thermistor's large resistance change per degree change in temperature provides good accuracy and resolution. A typical thermistor with a 200 Ω resistance at 25°C and a temperature coefficient of 0'029/°C shows a resistance change of 78 Ω/°C change in temperature.

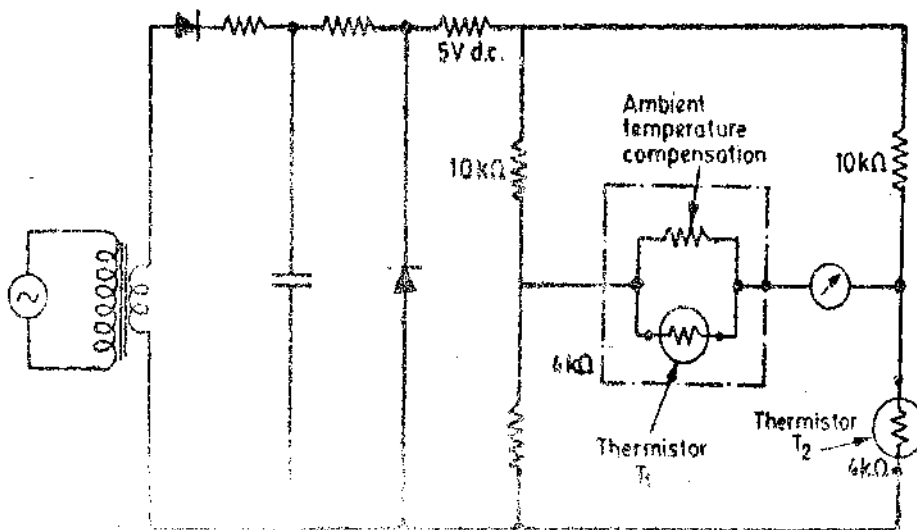

Fig 29'38'2. Measurement of temperature using two thermistors connected in bridge configuration.

Temperature measurements can be made by connecting a battery, a micro-ammeter and a thermistor in series. The resistance of the thermistor may be of the order of $10^5 \Omega$ or more and that of the leads is negligible. If the emf of battery, remains constant and if the current drawn by the circuit is limited to a value that will not raise the temperature of thermistor appreciably above ambient, the micro ammeter can be directly calibrated to read temperature. The micro ammeter can give a resolution of 0.1°C .

Where higher sensitivities are desired, a bridge circuit shown in Fig. 29'62 may be used.

This bridge circuit uses two thermistors T_1 and T_2 and a temperature compensating device.

The high sensitivity and high resistance of thermistors make them ideal devices for remote control and measurement of temperature as changes in contact or transmission resistances will not affect the readings

29'38'3. Salient Features of Thermistors.

1. Thermistors, are compact, rugged and inexpensive.
2. Thermistors when properly aged, have good stability.
3. The response time of thermistors can vary from a fraction of a second to minutes, depending on the size of the detecting mass and thermal capacity of the thermistor. It varies inversely with the dissipation factor. The power dissipation factor varies with the degree of thermal isolation of the thermistor element.
4. The upper operating limit of temperature for thermistors is dependent on physical changes in the material or solder used in attaching the electrical connections and is usually 400°C or less. The lower temperature limit of temperature is normally determined by the resistance reaching such a high value that it cannot be measured by standard methods.
5. The measuring current should be maintained to as low a value as possible so that self heating of thermistors is avoided otherwise errors are introduced on account of change of resistance caused by self heating. Where it is not possible to avoid self heating, thermistor stability can be maintained at given temperature by using an auxiliary heating element. The average power dissipation can be effectively reduced and the highest sensitivity retained by energizing the thermistor with pulses of measuring power.
6. Thermistors can be installed at a distance from their associated measuring circuits if elements of high resistance are used such that the resistance of leads even though the leads may be very long) is negligible. This way the resistance of leads does not affect the readings and hence errors on this count are negligible.

The above features give thermistors advantages over conventional thermocouples, resistance thermometers, and filled system thermometer sensing elements. Thermistors not only find use in temperature measurements but are also used in other applications.

Note : See Chapter 25 for solved examples on Resistance Thermometers and Thermistors. See pages 775 to 781 for solved examples and pages 823 and 824 for unsolved problems.

29'39. Thermocouples

The operation of thermocouples has been explained in Chapter 8, (see page 249). The emf produced in a thermocouple circuit is given by

$$E = a(\Delta t) + b(\Delta t)^2 \text{ (Eqn. 8'74 on page 250)}$$

where Δt = difference in temperature between the hot thermocouple junction and the reference junction of the thermocouple,

and a, b = constants.

a is usually very large as compared with b and therefore emf thermocouple is $E \approx a(\Delta t)$

or
$$\Delta t \approx \frac{E}{a}$$

In a thermocouple temperature measuring circuit, the emf set up is measured by sending a current through a moving coil instrument, the deflection being directly proportional to the emf. Since emf is a function of temperature difference Δt , the instrument can be calibrated to read the temperature. The emf may also be measured by a potentiometer.

Fig. 29'63 shows a typical circuit of an iron constantan thermocouple.

Since the thermo-electric emf depends upon the difference in temperature between the hot junction and the reference junction, the temperature of the latter should remain absolutely constant in order that the calibration holds good and there are no errors on account of change in ambient temperature. The temperature of the reference junction is controlled for this purpose. The reference junction temperature is usually 0°C. Thermocouples are used for measurement of temperatures

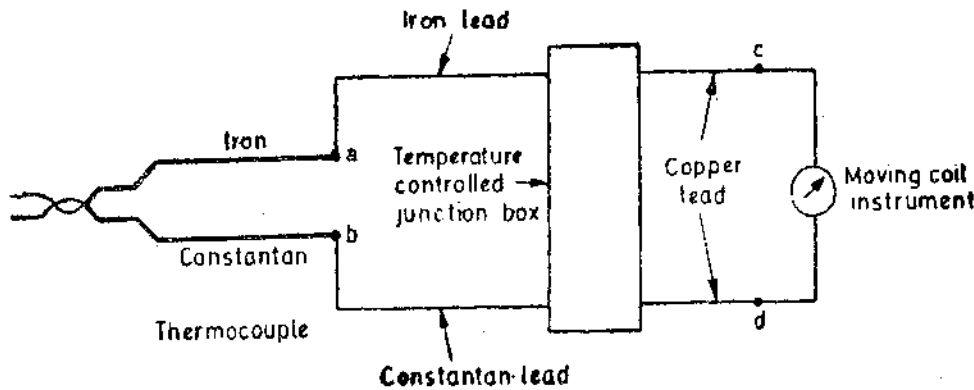

Fig. 29'63. Measurement of temperature with thermocouple.

upto 1400°C. The common types of thermocouples are given in Table 29'2 together with useful temperature range. It should be mentioned here that the combination of metals be so chosen that a rise in temperature should always produce a linear rise in emf *i.e.* the value of 'b' (Eqn. 8'74) should be negligible.

The emf of many thermocouples follows the quadratic relationship given by Eqn. 8'74. Fig. 29'64 shows curves for several combinations of metals, when one of the junctions, reference junction, is kept at a temperature 0°C and the temperature of the other junction, the detecting junction, is the variable temperature (*i.e.* the temperature to be measured).

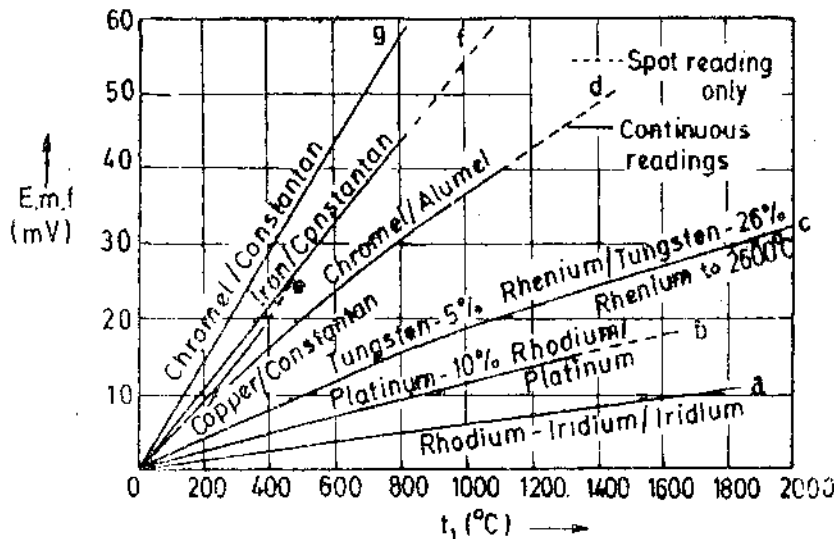

Fig. 29'64. Temperature emf curves for thermocouples with reference junction at 0°C.

29'39'1. Thermocouple Construction

In industrial applications the choice of materials used to make up a thermocouple depends upon the temperature range to be measured, the kind of atmosphere to which the material will be exposed

TABLE 29.2
Industrial Thermocouples

	Base-metal couples			Rare metal couples			
<i>Positive wire</i>	Copper	Iron	Chromel 90% Cr. 10% Ni	Chromel	Platinum 90% rhodium 10%	Tungsten 95% rhenium 5%	Rhodium iridium
<i>Negative wire</i>	Constantan 40% Ni, 60% Cu approx.	Constantan	Alumel 94% Ni, 2% Al, S ² and Mn	Constantan	Platinum	Tungsten 72% rhenium 26%	iridium
<i>Temperature range (°C)</i>	-250 to +400	-200 to +850	-200 to -1100	-200 to +850	0 to +1400	0 to +2600	0 to +2100
<i>Spot maximum (°C)</i>	500	1100	1300	1100	1650		
<i>Characteristics</i>	Resists oxidising and reducing atmospheres up to 350°C. Requires protection from acid fumes.	Low cost. Corrodes in the presence of moisture oxygen, and sulphur-bearing gases. Suitable for reducing atmosphere.	Resistant to oxidising but not to reducing atmosphere. Susceptible to attack by carbon-bearing gases sulphur, and cyanide fumes.	Suitable for oxidising but not for reducing atmospheres, carbon-bearing gases and cyanide fumes. High emf.	Low emf. Good resistance to oxidising atmospheres, poor with reducing atmospheres. Calibration is affected by metallic vapours and contact with metallic oxides.	For use in non-oxidising atmospheres only. The 5% rhenium arm is brittle at room temperatures.	Similar to platinum-rhodium-platinum.

to output emf and its stability, mechanical strength, and the accuracy required in measurements. Thermocouple materials are divided into two categories: (i) Rare metal types using platinum, rhodium, etc. and (ii) Base metal type.

Several combinations of dissimilar metals make good thermocouples for industrial use. These combinations apart from having linear response and high sensitivity, should be physically strong to withstand high temperatures, rapid temperature changes, and the effect of corrosive and reducing atmospheres. Based on years of experience in application of thermocouples, industry has standardized a few wire combinations.

Thermocouples are seldom used as bare wires, except for detecting hot junction. A hot junction arrangement is shown in Fig. 29.65. It is a simple arrangement consisting a pair of wires insulated by ceramic sleeves. The ends of the wires are either twisted together or welded.

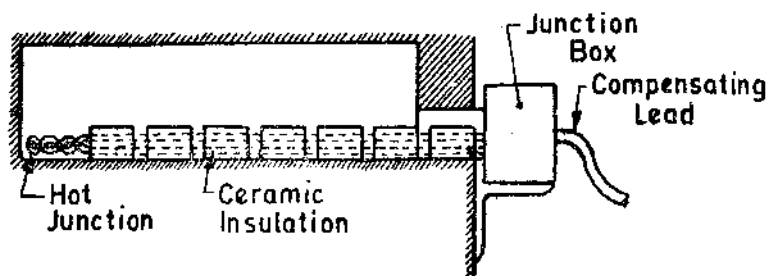

Fig. 29.65. Hot junction with ceramic insulations.

Fig. 29'66 shows a few arrangements for hot junctions which are more robust. They have wires insulated by mineral insulation and protected by a stainless steel outer casing which prevents the ingress of damaging hot gases or damage due to force or pressure. Thermocouples are available in a variety of sizes ranging from 0.25 mm to 3 mm.

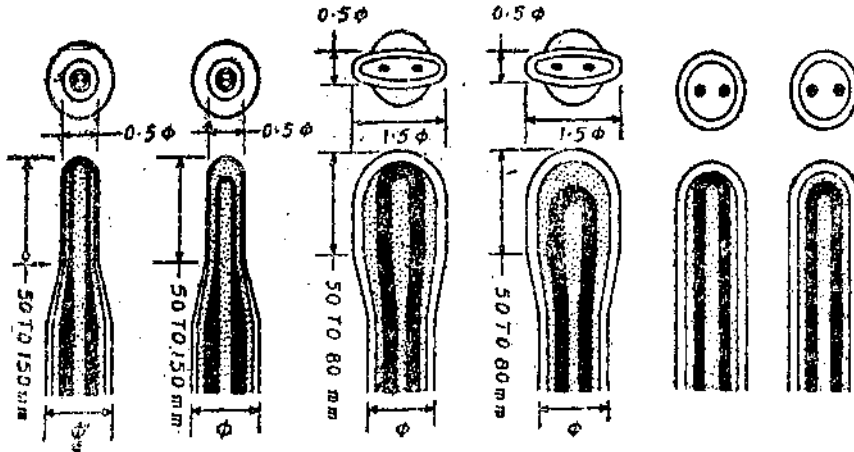

Fig. 29'66. Construction of hot junctions.

The sensitivity of thermocouple can be increased by reducing the mass of the measuring junction. One method of reducing the mass is to butt weld the two thermocouple wires. In applications where the mechanical strength of the butt weld is not sufficient, the two wires are twisted together and the ends are welded.

29'39'2. Measurement of Thermocouple Output

The output emf of a thermocouple as a result of difference between temperatures of measuring junction and reference junction can be measured by the following methods :

(i) Measuring the output voltage directly with a permanent magnet moving coil (PMMC) instrument. A millivoltmeter is used since the output is the order of mV.

(ii) Measuring the output voltage with the help of a d.c. potentiometer.

(iii) Measuring the output voltage after amplifying it.

1. **Millivoltmeter.** The simplest type of temperature measurement using a thermocouple is by connecting a sensitive milli-voltmeter across the cold junction. The deflection is proportional to the current flowing in the circuit. If the resistance of meter is R_m and that of the external circuit

is R_e , the current is $i = \frac{E}{R_m + R_e}$.

In order to ensure sufficient current to deflect the movement the resistance of the meter should be small since the sensitivity of thermocouples is quite small and they produce an output voltage which is a few mV/100 °C. Industrial moving-coil thermocouple instruments commonly have a resistance of about 50 Ω and the resistance of the external circuit (resistance of thermocouple and its leads) is about 10–20 Ω. Thus there will be large loading errors if this method of measurement is used. These errors can be eliminated if a high resistance is used in series with the instrument both to have a high input resistance and to swamp out errors caused on account of variation in resistance of leads.

2. **Potentiometers.** The most commonly used method for measurement of temperature with thermocouple employs a d.c. self balancing potentiometer described in Art. 14'14 on page 469. There are no loading errors as at balance no current is drawn from the thermocouple whose emf is being measured. The resistance variation problems are also absent when potentiometers are used.

Many types of automatic potentiometers have been developed both for automatic recording of temperatures on chart recorders and for automatic process control,

3. **Amplifiers with Output Devices.** The use of transistors and integrated circuit methods has led to the development of compact and cheap d.c. amplifiers. The amplifiers amplify the output of the thermocouple and feed to indicating or recording devices. These devices may be either analog or digital type. In this case also, the loading errors and errors on account variation of resistance are absent. Therefore there are no circuit problems. But a disadvantage of these methods is that they require an auxiliary source of power while direct deflection method do not require any separate source.

29'39'3. **Compensating Circuits.** When temperatures near ambient are to be measured with a thermocouple and it is inconvenient to use a fixed reference junction, compensating circuits must be employed in the measuring system. An arrangement for automatic compensation is shown in Fig. 29'67. A temperature sensitive bridge is included in the thermocouple circuit, such that variations in the ambient temperature are compensated for by the changes in the resistance R_c and the compensating junction.

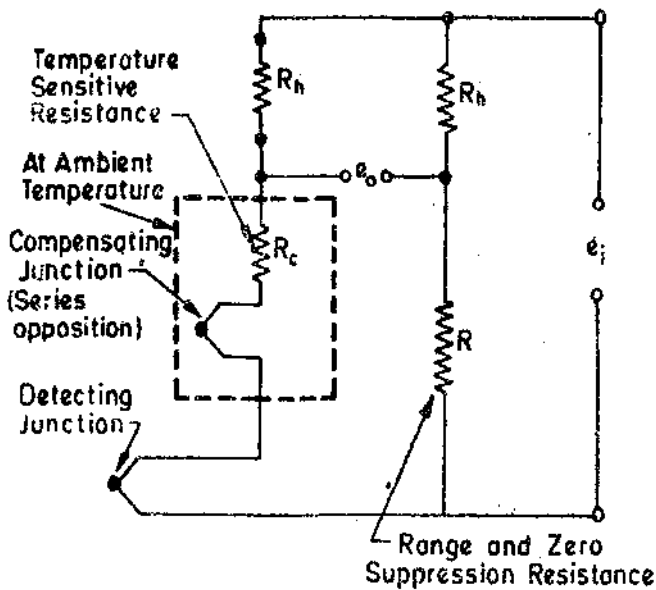

Fig. 29'67. Thermocouple with bridge type compensation.

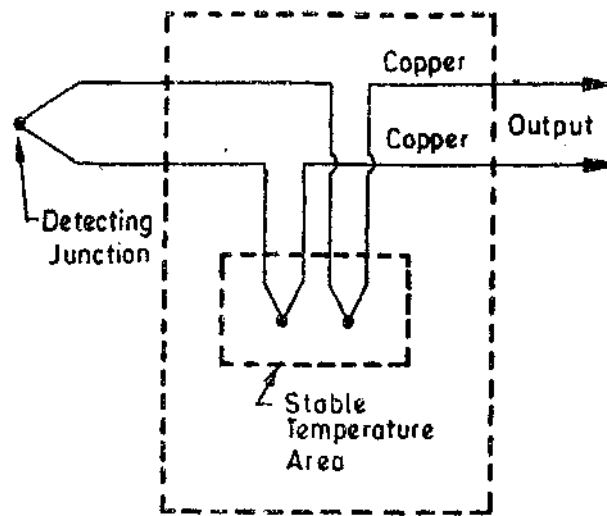

Fig. 29'68. Thermocouple reference junction.

Multichannel thermocouple systems sometimes use a heated, thermostatically controlled reference junction as shown in Fig. 29'67. By using a regulated temperature control of the reference junction, an accuracy of $\pm 3\%$ can be obtained.

29'39'4. **Reference junction Compensation.** A factor which is important in the use of thermocouples is the requirement of a known reference temperature of the reference junction. This is because when the reference junction is not held at 0°C , the observed value must be corrected by adding to it a voltage that have resulted from a temperature difference equal to the amount by which the reference junction is above 0°C (This is because the thermocouples are calibrated with temperature of reference junction as 0°C).

Now $E_T = E_t + E_0$ where E_T is the total emf at temperature T , E_t is the emf on account of temperature difference between detecting (hot) and the reference junction and E_0 is the emf due to temperature of the reference junction being above 0°C . Since, there exists a non-linear relationship between the emf and the temperature, it is important that temperatures are determined by the above process rather than converting an emf to temperature and then adding it to ambient temperature.

29'39'5. **Lead Compensation.** In many applications it is desirable to place the reference junction at a point far removed from the measurement junction. The connecting wires from the thermocouple head to the meter are, therefore, very long and are usually not at the same temperature throughout their length. This causes errors, which can be avoided by using connecting wires made of the same material as the thermocouple wires. The implementation of this arrangement

may not be possible in many cases due to cost and other considerations. Under these circumstances, materials are chosen such that the relationship between emf and temperature is the same or almost the same as that for thermocouple wires. These wires are then called **Compensating Leads**.

29'39'6. Advantages and Disadvantages of Thermocouples

Advantages. 1. Thermocouples are cheaper than the resistance thermometers.

2. Thermocouples follow the temperature changes with a small time lag and as such are suitable for recording comparatively rapid changes in temperature.

Thermocouples are very convenient for measuring the temperature at one particular point in a piece of apparatus.

Disadvantages. 1. They have a lower accuracy and hence they cannot be used for precision work.

2. To ensure long life of thermocouples in their operating environments, they should be protected in an open or closed-end metal protecting tube or well. To prevent contamination of the thermo-couple, when precious metals like platinum or its alloys are being used, the protecting tube has to be made chemically inert and vacuum tight.

3. The thermocouple is placed remote from measuring devices. Connections are thus made by means of wires called extension wires. Maximum accuracy of measurement is assured only when compensating wires are of the same material as the thermocouple wires. The circuitry is, thus, very complex.

Example 29'30. Calculate the thermoelectric sensitivity of a device using bismuth and tellurium as the dissimilar metals. Estimate the maximum output voltage for a 100°C temperature difference at room temperature using one junction. The sensitivity of bismuth is $-72 \mu\text{V}/^{\circ}\text{C}$ and that of tellurium is $500 \mu\text{V}/^{\circ}\text{C}$.

Solution. Sensitivity of thermocouple $= 500 - (-72) = 572 \mu\text{V}/^{\circ}\text{C}$.

\therefore Voltage output for a temperature difference of $100^{\circ}\text{C} = 572 \times 10^{-6} \times 100 = 57.2 \text{ mV}$.

Example 29'31. A chromel-alumel hot junction is connected to a potentiometer. This is at a temperature of 20°C and gives a reading of 27.07 mV . Determine the measured temperature assuming the thermocouple to conform to the values given in Fig. 29'62 which are based on reference junction at 0°C . The emf corresponding to a temperature of 20°C is 0.8 mV . Consult curves given in Fig. 29'62.

Solution. The measured emf is the algebraic sum of emfs at the hot and reference junctions.

\therefore Required emf is $e_T = e_t + e_0 = 27.07 + 0.8 = 27.87 \text{ mV}$.

Corresponding to this emf the temperature is 620°C .

Example 29'32. A thermocouple circuit uses a chromel-alumel thermocouple which gives an emf of 33.3 mV when measuring a temperature of 800°C with reference temperature 0°C . The resistance of the meter coil, R_m is 50Ω and a current of 0.1 mA gives full scale deflection. The resistance of junctions and leads, R_s , is 12Ω . Calculate :

(a) Resistance of the series resistance if a temperature of 800°C is to give full scale deflection.

(b) the approximate error due to rise of 1Ω in R_s .

(c) the approximate error due to a rise of 10°C in the copper coil of the meter. The resistance temperature co-efficient of coil is $0.00426/^{\circ}\text{C}$.

Solution. (a) Emf $E = i(R_m + R_s + R_e)$ or $33.3 \times 10^{-3} = 0.1(50 + R_s + 12)$
or Series resistance $R_s = 271 \Omega$.

(b) Current in the circuit with increased resistance = $\frac{33.3 \times 10^{-3}}{50 + 271 + 12} = 0.0997 \text{ mA}$.

\therefore Approximate error in temperature = $\frac{0.0997 - 0.1}{0.1} \times 800 = -2.4^{\circ}\text{C}$.

(c) Change in resistance of coil with a temperature increase of $10^{\circ}\text{C} = 50 \times 0.00426 \times 10 = 2.13 \Omega$.

Current in the circuit with increased resistance of coil = $\frac{3.33 \times 10^{-3}}{50 + 2.13 + 271 + 12} \text{ A} = 0.09936 \text{ mA}$.

\therefore Approximate error in temperature = $\frac{0.1 - 0.09936}{0.1} \times 800 = -5.12^{\circ}\text{C}$.

Example 29.33. The simple potentiometer circuit of Fig. 29.69 is to work from a platinum/platinum rhodium 10 per cent thermocouple and have a measuring range of $900^{\circ}\text{C} - 1200^{\circ}\text{C}$.

The scale readings are to be correct for a reference junction temperature of 20°C . The slide wire resistance is 2.5Ω and the circuit is standardized to give 1.08 V between A and B. Find the values of resistance R_1 and R_2 . Data from thermocouple tables for platinum/platinum-rhodium 10 per cent with 0°C reference junction temperature is :

- emf for $20^{\circ}\text{C} = 0.112 \text{ mV}$,
- emf for $900^{\circ}\text{C} = 8.446 \text{ mV}$,
- emf for $1200^{\circ}\text{C} = 11.946 \text{ mV}$.

Solution. The resultant emfs at the detecting junction temperature of t_1 and reference junction temperature of $t_2 = 20^{\circ}\text{C}$, are

at 900°C , $E_1 = 8.446 - 0.112 = 8.334 \text{ mV}$
 and at 1200°C $E_2 = 11.946 - 0.112 = 11.834 \text{ mV}$.

With the same standardising current, the emfs are :

$$E_{ac} = \frac{1.08}{R_1 + 2.5 + R_2} \times R_1 = 8.334 \times 10^{-3} \quad \dots(i)$$

and $E_{ad} = \frac{1.08}{R_1 + 2.5 + R_2} \times (R_1 + 2.5) = 11.334 \times 10^{-3} \quad \dots(ii)$

Dividing (ii) by (i), we have $\frac{R_1 + 2.5}{R_1} = \frac{11.334}{8.334}$ or $R_1 = 5.95 \Omega$

Substituting the value of R_1 in (i), we get $R_2 = 762.6 \Omega$.

29.40. Quartz Crystal Thermometer

A quartz crystal possesses a property that its resonant frequency changes with the change in temperature. This property is made use of in quartz crystal thermometer for measurement of temperature. This is a novel and extremely accurate method for measurement of temperature.

If the quartz crystal is given a proper angle cut, there exists a linear relationship between resonant frequency and the temperature. The resonant frequency is, therefore, a measure of the temperature. The frequency is measured with the help of digital frequency meters and is displayed.

The advantage of this thermometer is that sensitivities of the order of 0.001°C are obtained. Also the thermometer is insensitive to stray pickups in the connecting cables since the output is frequency which is measured by digital techniques.

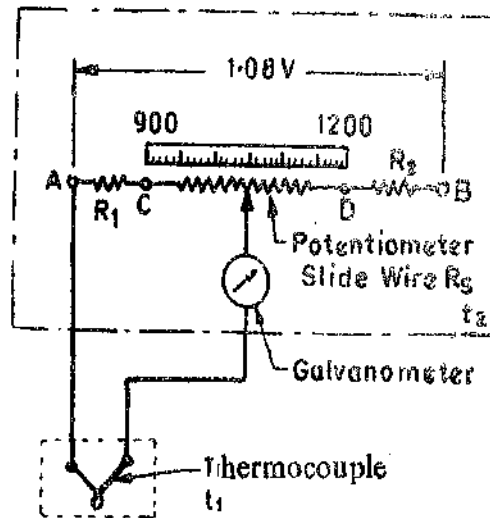

Fig. 29.69

29.41. Radiation Pyrometers

When temperatures being measured are very high and physical contact with the medium to be measured is impossible or impractical, use is made of thermal radiation methods or optical pyrometers are used. These pyrometers are used under conditions where corrosive vapours or liquids would destroy thermocouples, resistance thermometers and thermistors if made to come in contact with the measured medium. These pyrometers find applications for temperatures which are above the range of thermocouples and also for rapidly moving objects.

Radiation pyrometry measures the radiant heat emitted or reflected by a hot object. Thermal radiation is electromagnetic radiation emitted as a result of temperature. Thermal radiation lies in the wavelength region from about 0.1 to 100 μm . Practical radiation pyrometers are sensitive to a limited band of radiant energy, although the theory indicates that they should be sensitive to entire spectrum of energy radiated by the object.

The radiation pyrometers operate on the principle that the energy radiated from a hot body is a function of its temperature. According to Stefan Boltzmann law, the heat radiated per square metre from body is :

$$q = 5.72 \times 10^{-8} e (T_1^4 - T_2^4) \text{ W/m}^2$$

where T_1 = absolute temperature of radiating hot body ; K, T_2 = absolute temperature of surroundings ; K

e = co-efficient of emissivity (=1 for perfect black bodies)

$$\therefore \text{Heat radiated by a perfect black body } q_b = 5.72 \times 10^{-8} (T_1^4 - T_2^4) \text{ W/m}^2.$$

The heat radiated by the hot body is focussed on a radiation detector as shown in Fig. 29.70.

The radiation detector is blackened so as to approach as nearly as possible to the theoretical black body and absorbs all or almost all radiation falling upon it.

Heat absorbed by radiation detector $q_b = 5.72 \times 10^{-8} [T_1^4 - T_2^4] \text{ W/m}^2$

If temperature of detector is very small as compared with that of hot body, we have $q_b = 5.72 \times 10^{-8} T_1^4 \text{ W/m}^2$

Therefore the heat received by the detector is proportional to the fourth power of absolute temperature of hot body.

29.41.1. Principles used for Radiation Temperature Measuring Devices

There are two principles used for construction of radiation temperature measuring devices.

1. **Total Radiation Pyrometry** : In this case the total radiant energy from a heated body is measured. The radiation pyrometer, then, is intended to receive maximum amount of radiant energy at widest range of wavelengths possible.

2. **Selective (or Partial) Radiation Pyrometry**. In this case we may measure the spectral radiant intensity of the radiated energy from the heated body at a given wavelength.

Actually it is difficult to build a practical pyrometer that is responsive to radiation of all wavelengths or to spectral radiation of one wavelength. Therefore practical radiation pyrometers respond to a wide band of radiation of approximately 0.1 to 8 μm width in the visible and infrared band of radiation spectrum.

29.41.2. Radiation Receiving Elements

The purpose of a radiation-temperature measuring device is to convert the radiant energy into a suitable form for indication of temperature. For this purpose the following devices are used.

1. **Vacuum Thermocouple**. A vacuum thermocouple comprises of a thermo junction of extremely thin strips which are blackened. The thermocouple is enclosed in an evacuated housing with a suitable window to admit the radiant energy as shown in Fig. 29.71. The heat loss from the

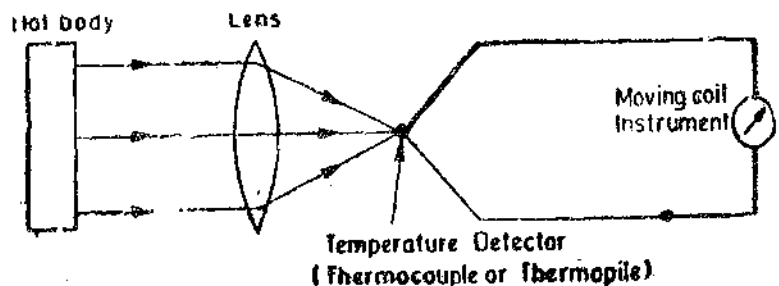

Fig. 29.70. Measurement of temperature with Radiation Pyrometers.

thermocouple due to conduction and convection is greatly reduced because of the evacuated envelope. This results in appreciable temperature rise of the detecting junction and therefore a measurable emf can be obtained even for a small radiant energy received at the detecting junction. Since the thermocouple has a low mass and is placed in vacuum, it can respond to rapid changes in radiant energy.

2. **Thermopile.** In industrial applications in which a vacuum thermocouple is needed for its speed of response, it is current practice to assemble several thermocouples in series to form a thermopile. A thermopile consists of a group of very small thermocouples as shown in Fig. 29.72 so connected in series that their emfs are additive. This gives an increased sensitivity. The tiny thermocouple junctions, about pin point size, are flattened and blackened so that they absorb all the radiant energy reaching them.

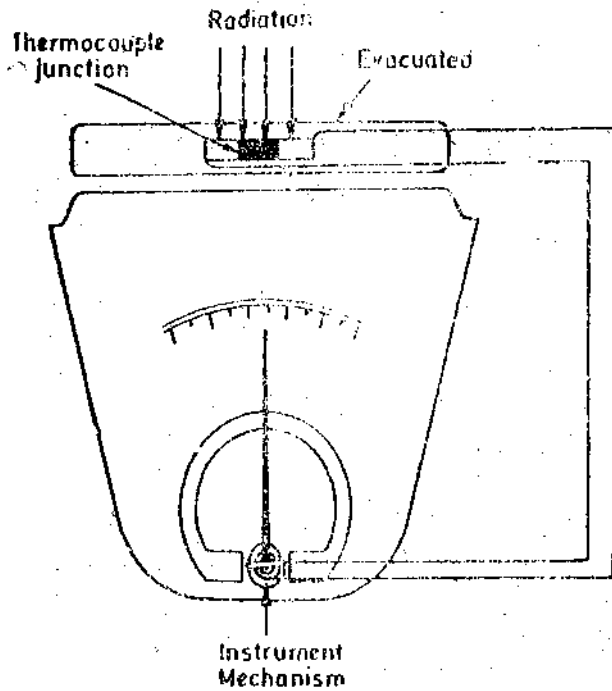

Fig. 29.71. Measurement of temperature with vacuum thermocouple.

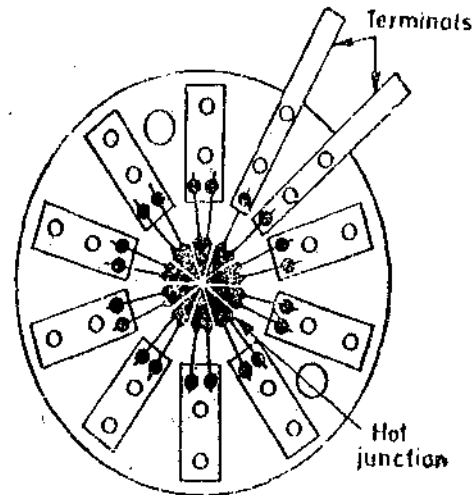

Fig. 29.72. Thermopile.

Pyrometers incorporating thermocouple or thermopiles do not require compensating cable between the pyrometer and the display. The sensitive element is required to measure its own temperature change, due to radiant energy received, relative to the temperature of the immediate surroundings, *i.e.* the body of the instrument. This is achieved by locating the reference junction or junctions within the body of the instrument, in a position shielded from direct radiation from the heated body.

Varying ambient temperatures, which may affect the thermopile, are compensated for by a nickel resistance spool. This spool provides a variable shunt across the emf produced. As the ambient temperature increases or decreases, the corresponding resistance changes of the nickel coil varies the emf output of the head resulting in accurate compensation over the entire range of the instrument.

A thermopile has longer speed of response but normally speeds of response of less than several seconds are not important in most industrial applications. Typical response time is 2 s and higher.

3. **Bolometer.** A bolometer is a thermal device that changes its electrical resistance with temperature. The resistance of the bolometer changes in response to the thermal radiation focussed on it. A bolometer is made of thin ribbon or platinum or nickel depending upon the response required. The change in resistance is measured by a Wheatstone bridge. In fact two thin strips are used which form two arms of a Wheatstone bridge. One strip is exposed to the radiation. The other

strip is shielded and compensates for any change in the ambient temperature. Absorption of radiant thermal energy by the exposed strip results in increase of resistance of the strip which is measured by the bridge calibrated in terms of temperature

Bolometers have a fast response but are expensive to construct and are less rugged than other detectors.

4. Photo-electric Transducers. Photo-electric transducers are discussed in details in Chapter 19. (See Art. 19.22 page 626 onwards). Photo electric transducers used for detection of radiant energy are photo-emissive cells, photo conductive cells and photovoltaic cells. The output of these cells varies with the amount of radiant energy incident on them. In general the photo electric transducers are sensitive to given portions of the spectrum and therefore they are used with partial radiation and optical radiation pyrometers.

Photo-electric detectors are very rugged and also have a very fast response.

29.41.3. Total Radiation Pyrometers

The total radiation pyrometer receives virtually all the radiation from a particular area of hot body and focuses it on a sensitive temperature transducer like thermocouple, thermopile, bolometer etc. The term total radiation includes both the visible (light) and invisible (infrared) radiations.

The total radiation pyrometer consists of a radiation-receiving element and a measuring device to indicate the temperature directly.

The mirror type radiation receiver is shown in Fig. 29.73. Here diaphragm unit along with a mirror is used to focus the radiation on a radiant energy sensing transducer. The lens to transducer (a vacuum thermocouple or a thermopile) distance is adjustable for proper focus. The mirror arrangement has an advantage that since there is no lens, the absorption and reflection effects are absent.

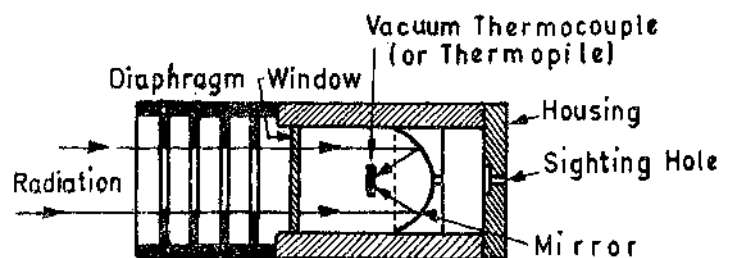

Fig. 29.73. Mirror type radiation receiving device.

The mirror type of radiation receiver shown in Fig 29.73 is so arranged that the image of the front diaphragm is focused on the thermocouple by the mirror. Therefore, the temperature measurements are independent of the distance of the target if the field of view is filled.

Presence of any absorbing media between target and the transducer reduces the radiation received that therefore the pyrometer reads low. Substances like smoke, dirt and gases absorb radiation and therefore cause negative static errors. On the other hand presence of heat sources like hot gases, high temperature particles and flame cause the meter to read high.

Due to the fourth power law ($q \propto T^4$) the characteristics of total radiation pyrometer are non-linear and the device exhibit poor sensitivity in the lower temperature ranges. For example any output voltage 2 mV for temperature change of 0°C to 500°C is typical. In spite of this lower sensitivity, total radiation pyrometers are used for low temperature applications instead of partial radiation pyrometers which give better results in applications involving measurement of high temperatures. Total radiation pyrometers cannot be used for temperatures lower than 600°C since at lower temperatures error may be introduced by the fact that the temperature of the pyrometer itself may not be negligible as compared with that of hot body. Therefore total radiation pyrometers are used for a temperature range of 1200°C to 3500°C.

The output from a total radiation pyrometer whether amplified or not, is usually taken to a PMMC instrument, or to a self-balancing potentiometer. Digital displays are also being increasingly used. The output may be fed to a recorder for recording or to a controller for control purposes.

29'41'4. Infrared Pyrometers

Infrared pyrometers are partial or selective radiation pyrometers. Infrared energy is invisible to the human eye, but can be felt. There is a proportional increase in infrared energy as the temperature of the surface radiating body increases. Above temperatures of approximately 550°C , a surface starts to radiate visible light energy and simultaneously there is a proportional increase in the infrared energy. This proportional increase in infrared energy with surface energy makes infrared pyrometry possible by combining a suitable detector, electronic circuitry, and means of indication and/or control. The infrared spectrum ranges from $0.22\ \mu\text{m}$ to $17\ \mu\text{m}$ and the commonly used portion is 2 to $7\ \mu\text{m}$. Some manufacturers use only 5 to $7\ \mu\text{m}$ portion of the range for the purposes of pyrometry.

Infrared principles using vacuum thermocouples, thermopiles and bolometers have been successfully employed in infrared spectrometers as well as in total radiation pyrometers.

Various types of photo-electric transducers are most commonly used for Infrared transducers. The most successful transducer used for industrial applications is the photovoltaic cell. The cell used in radiation pyrometers, in fact, responds to wavelengths in infrared region, rather than to visible light, and may be used to measure temperatures down to about 400°C .

An outstanding feature of the pyrometers based on photovoltaic cells is their high speed of response. The time to reach 98% of full response to a step input are of the order of 1 ms, as compared with several seconds for a total radiation pyrometer.

The infrared radiation is focused on to a photo-voltaic cell and therefore it is necessary to

insure that the cell does not become overheated. A radiant energy receiver is shown in Fig 29'74. The cone of radiation passing ultimately to the photo cell is defined by the area of the first diaphragm. The protective window is made of thin glass and serves to protect the cell and filter from physical damage. The filter is used in the range of 1000°C to 1200°C in order to reduce the infrared radiation passed to the photo cell. This helps in preventing the photo cell from getting overheated.

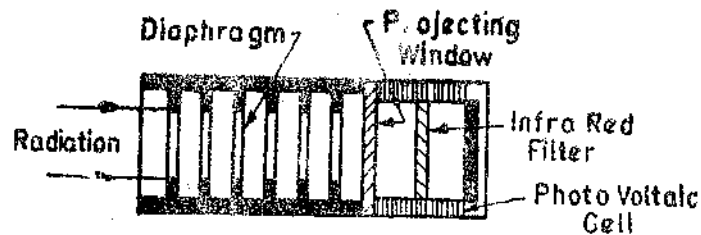

Fig. 29'74. Infrared pyrometer.

insure that the cell does not become overheated. A radiant energy receiver is shown in Fig 29'74. The cone of radiation passing ultimately to the photo cell is defined by the area of the first diaphragm. The protective window is made of thin glass and serves to protect the cell and filter from physical damage. The filter is used in the range of 1000°C to 1200°C in order to reduce the infrared radiation passed to the photo cell. This helps in preventing the photo cell from getting overheated.

All infrared systems depend upon the transmission of the infrared radiant energy being emitted by a heated body to a detector in the measuring system through surroundings. There is no direct contact with the surface whose temperature is being measured. The sensor head is focused on the object whose temperature is being measured and/or controlled. The infrared energy falling on the detector either changes the detector resistance in proportion to temperature, as in the case of a thermistor, or generates an emf in the detector, such as a thermopile. The change in resistance or generated emf is then indicated on a meter or a digital display or is used to operate a controller for the process.

29'41'5. Optical Pyrometers

The radiations from a heated body at high temperatures fall within the visible region of the electromagnetic spectrum. For a given wavelength in the visible region the energy radiated is greater at higher temperatures. Within the visible region a given wavelength has a fixed colour and the energy of radiation is interpreted as intensity or brightness. Therefore if we measure brightness of the light of a given colour emitted by a hot source, we can have an indication of temperature. This is the principle on which an optical pyrometer works.

In an optical pyrometer the wavelength of radiation accepted is restricted by means of a colour filter and the brightness is measured by comparison with a standard lamp.

Disappearing Filament Optical Pyrometer. The most common type of optical pyrometer is the "Disappearing Filament Pyrometer". The schematic diagram of this pyrometer is shown in Fig. 29 75.

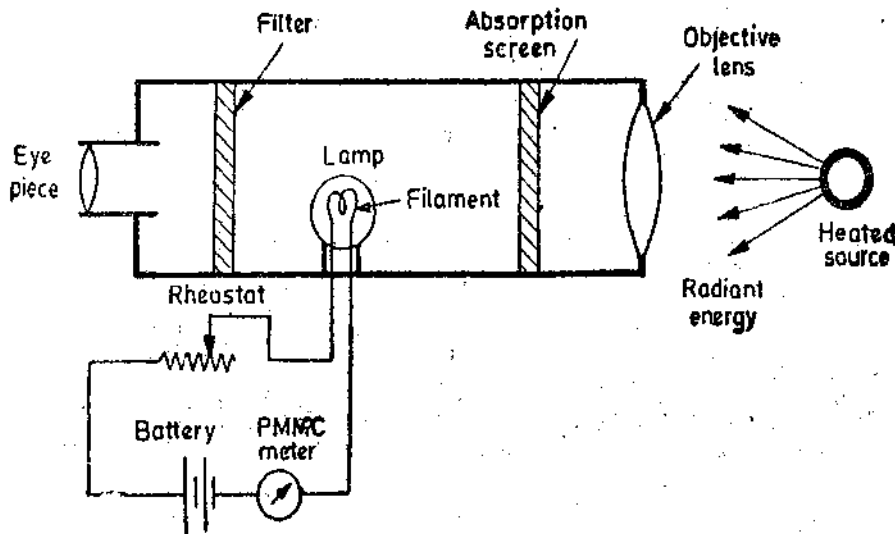

Fig. 29 75. Disappearing filament type optical pyrometer.

An image of the radiating source is produced by a lens and made to coincide with the filament of an electric lamp. The current through the lamp filament is made variable so that lamp intensity can be adjusted. The filament is viewed through an eye piece and a filter. The current through filament is adjusted until the filament and the image are of equal brightness.

When the brightness of image produced by the source and brightness produced by the filament are equal, the outline of the filament disappears as shown in Fig 29 76 (c).

However, if the temperature of the filament is higher than that required for the equality of brightness, it (filament) becomes too bright as shown in Fig. 29 76 (a). On the other hand, if the temperature of filament is lower, it becomes dark as shown in Fig 29 76 (b).

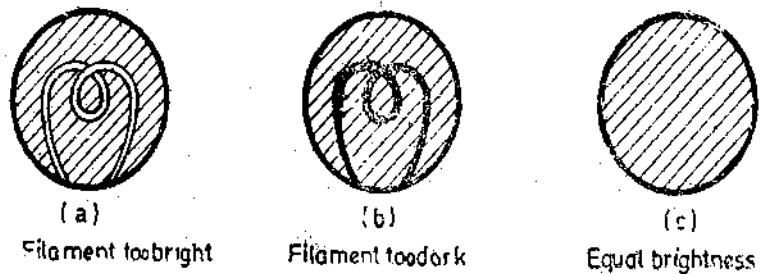

Fig. 29 76. Field view of disappearing-filament pyrometer.

Since the intensity of light of any wavelength depends upon the temperature of the radiating body and the temperature of filament depends upon the current flowing through the lamp, the instrument may be directly calibrated in terms of the filament current. However the filament current depends upon the resistance of the filament, therefore modern pyrometers are calibrated in terms of resistance of filament circuit.

The range of temperature which can be measured by instruments of this type is governed by the maximum allowable temperature of the lamp which is of the order of 1400°C. The range can be extended by using an absorption type screen near objective lens. Thus a known fraction of radiant energy enters the pyrometer for comparison. The range can be extended to 3000°C by adopting this technique.

This optical pyrometer is widely used for accurate measurement of temperature of furnaces, molten metals and other heated materials.

MEASUREMENT OF FLOW

29 42. Rate of Flow. There are a number of devices for sensing the rate of fluid flow. They mainly operate on the principle of placing an obstruction in the path of fluid causing a change in

fluid pressure which is dependent upon the rate of flow. Thus by measuring the difference in pressure before and after the obstruction by means of a differential pressure sensor, the rate of flow may be determined. They are, in fact, mechanical means of measuring rate of liquid flow. The examples of these flow meters are : Orifice plate, venturi tube and Ratometer. These are indirect means of measuring fluid flow. However, there are some direct methods of measuring fluid flow which are described below. These methods employ electrical means directly.

29'42'1. Turbine Meters

There have been extremely rapid developments in turbine meters in recent years, partly because of the advances in electronics technology and the ease with which the output may be used to indicate rate of flow or be integrated to give total flow. An exploded view of the meter is shown in Fig. 29'77.

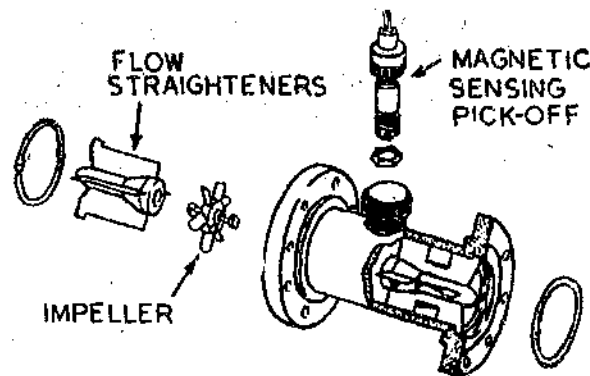

Fig. 29'77. Turbine flow meter.

Turbine flow meters are volumetric flow meters and are available in wide ranges. The output is usually in the form of a digital electrical signal whose frequency is directly proportional to flow rate and whose total count is proportional to the total quantity, as each pulse represents a discrete volume.

Fig. 29'77. shows a magnetic pickup type of turbine flow meter. A feature of this turbine meter is a hydraulically supported turbine rotor. A permanent magnet sealed inside the rotor body is polarized at 90° to the axis of the rotation. As the rotor rotates so does the magnet and therefore a rotating magnetic field is produced. This produces an a.c. voltage pulse in the pick-up coil located external to the meter housing. The frequency of this voltage is directly proportional to the rate of flow. The pulse can be totalized by a counter to give the value of total flow over a particular interval of time.

Advantages : (i) The output is in electrical digital form which lends itself admirably to line or radio telemetry for recording or control at a distant point.

(ii) Passage of rotor past the pick up coil produces an emf which can be converted to a d.c analog voltage by a D/A converter for indication on a conventional d.c instrument or recorded on a potentiometric recorder.

(iii) The pulse output may be summed on a simple counter giving totalized flow without loss of accuracy. The error is approximately $\pm 0.5\%$.

Limitations. (i) Errors may be caused by excessive frictional torques. Also errors arise on account of wear and corrosion of bearings. This calls for special design of bearings.

(ii) The turbine is subject to variations in performance caused by the characteristics of the liquid, friction or bearings, etc. When the flow rates approach zero, the slippage may amount to 100%, i.e. the turbine stalls and registers zero output. Therefore, at low flow rates, there is a possibility of large errors.

29.42.2. Electromagnetic flow meters

Electromagnetic flow meters are particularly suitable for the flow measurements of slurries, sludge and any electrically conducting liquid.

A schematic diagram of an electromagnetic flowmeter is shown in Fig 29.78. It consists basically of a pair of insulated electrodes buried flush in the opposite sides of a non-conducting, non-magnetic pipe carrying the liquid whose flow is to be measured. The pipe is surrounded by an electromagnet which produces a magnetic field. The arrangement is analogous to a conductor moving across a magnetic field. Therefore, voltage is induced across the electrodes. This voltage is given by: $E = B l v$ volt where $B = \text{flux} \times \text{density}$; Wb/m^2 , $l = \text{length of conductor} = \text{diameter of pipe}$; m ,

$v = \text{velocity of conductor (flow)}$; m/s

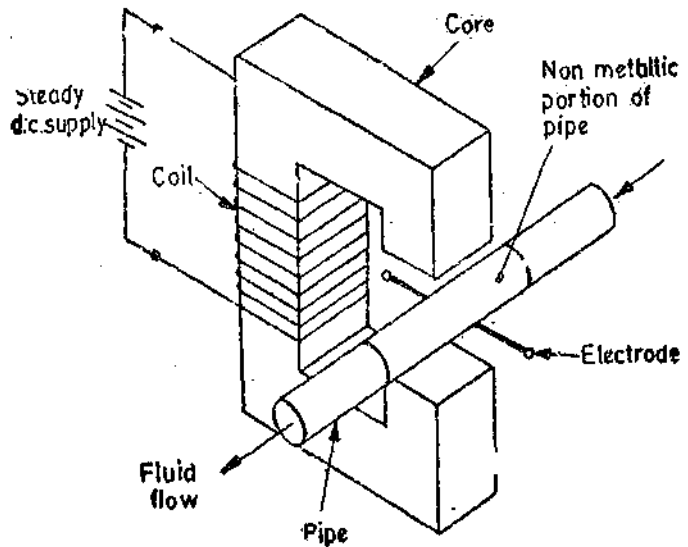

29.78. Electromagnetic flow meter.

Thus, assuming a constant magnetic field, the magnitude of the voltage appearing across the electrodes will be directly proportional to velocity.

Non-conducting pipe has to be used as the output voltage gets short circuited if metallic pipes are used. This is true when liquids of low conductivity are being measured. But when liquids of high conductivity are measured the short circuiting has no effect. Stainless steel pipes can then be used. The voltages produced are small specially at low flow rates. Therefore, the meter relies greatly on a high gain amplifier to convert the induced voltage into a usable form.

Advantages: (i) The electromagnetic flowmeters may be manufactured to measure flow in pipes of any size provided powerful magnetic field can be produced.

(ii) The major advantage from a fluid handling point of view is that with the electromagnetic flow meter there is no obstruction to flow that may cause pressure drops.

(iii) The output (voltage) is linearly related to the input (flow rate).

(iv) The output is unaffected by changes in characteristics of liquid such as viscosity, pressure, and temperature.

Limitations: (i) The operating costs are high particularly if heavy slurries are handled.

(ii) The conductivity of the liquid being metered should not be less than $10 \mu \text{ S/m}$. As a general rule it will be found that most aqueous solutions are adequately conductive while majority of hydrocarbon solutions are not sufficiently conductive.

Comparison of D.C. and A.C. Excitation. The magnetic field used in electromagnetic flow meters can either be d.c. or a.c. giving rise to d.c. or an a.c. output signal respectively. The d.c. is used in limited applications due to many reasons:

(i) When d.c. excitation is used for materials of very low conductivity and flowing at slow speeds, the output emf is too small to be easily read off. This has to be amplified for display and recording purposes. The d.c. amplifiers have many inherent problems especially at low levels. High amplification can be more easily, cheaply and more reliably done with a.c. than with d.c. Therefore these applications require the use of a.c. excitation of electromagnet to produce a.c. emfs which can be easily amplified by a.c. amplifiers and then fed to the display units.

(ii) Many hydrogen bearing or aqueous solutions exhibit polarization effects when the excitation is d.c. The positive ions migrate to the negative electrode and disassociate, forming an insulating pocket of gaseous hydrogen. There is no such action when a.c. is used.

(iii) Another phenomenon which happens with use of d.c. is that the d.c. field may distort the fluid-velocity profile by magnetohydrodynamic (MHD) action. An a.c. field (50 Hz) has little

effect on velocity profiles because fluid inertia and friction forces at 50 Hz are sufficient to prevent any large fluid motions.

(iv) Since the output of electromagnetic flow meters is quite small (a few mV), interfering voltage inputs due to thermocouple type of effects and galvanic action of dissimilar metals used in meter construction may be of the same order as the signal. Since the spurious interfering inputs are generally drifts of very low frequency, the 50 Hz a.c. system can use high pass filters to eliminate them.

(v) While a.c. systems predominate, d.c. type of systems have been used for flow measurements of liquid metals like mercury. Here, no polarization problem exists. Also, an insulating pipe liner or a non-metallic pipe is not needed since the conductivity of the liquid metal is very good relative to an ordinary metal pipe. (Usually stainless steel pipes are used). This means that the metal pipe is not very effective as a short circuit for the voltage induced in the flowing liquid metal. When metallic pipes are used as with d.c. excitation no special electrodes are necessary. The output voltage is tapped off the metal pipe itself at the points of maximum potential difference.

29'42 3. Hot Wire Anemometers

The hot wire anemometer is a device that is most often used in research applications to study varying flow conditions.

When a fluid flows over a heated surface, heat is transferred from the surface and therefore its (surfac's) temperature reduces. The rate of reduction of temperature is related to flow rate.

In a hot wire anemometer, heat is supplied electrically to a fine wire placed in the flow stream. The temperature of wire is determined by measuring its resistance with a Wheatstone bridge. One method involves adjusting the current through the wire so that the temperature remains constant, and measuring the heating current. In this way the bridge remains always balanced. The current is measured by finding the voltage drop across a standard resistor connected in series with the heating wire (See Fig. 29'79). The voltage drop is found by using a potentiometer.

It can be shown that the loss of heat from the heated wire is :

$$= a(v\rho + b)^{1/2} \quad J/s$$

where v = velocity of heat flow, ρ = density of fluid, and a and b are constants.

Constants a and b depend upon dimensions and physical properties of wire and fluid. The values of these constants are found by calibrating the instrument against a static pitot tube.

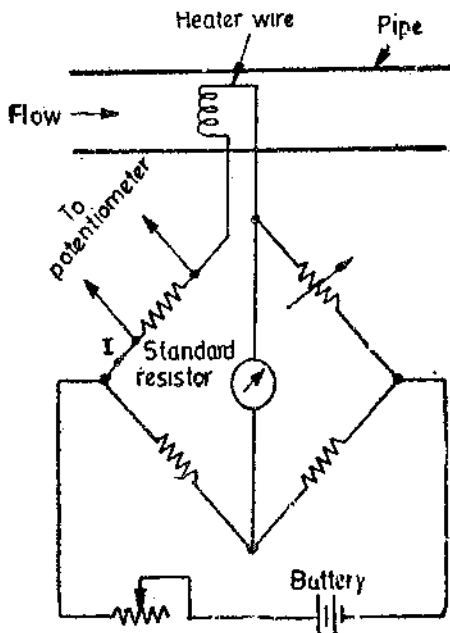

Fig. 29'79. Measurement of rate of fluid flow using a hot wire anemometer.

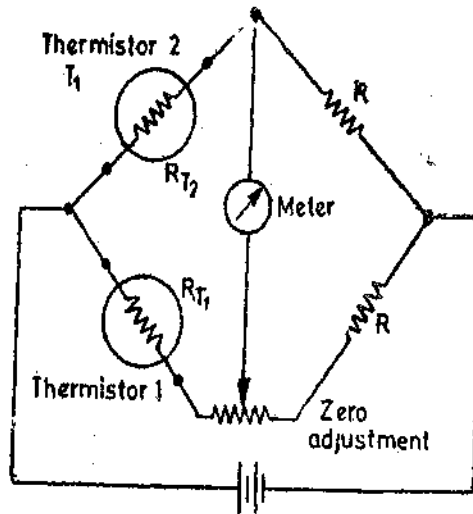

Fig. 29'80. Flow measurements using a bridge circuit having two thermistors.

Now supposing a current I flows through the wire having a resistance R . Therefore under equilibrium conditions,

$$\text{heat generated} = \text{heat lost or } I^2 R = a(v\rho + b)^{1/2} \text{ or } v = \frac{(I^2 R^2/a^2 - b)}{\rho}$$

Thus if the resistance and the temperature of the wire are kept constant, the rate of fluid flow can be measured by measuring current, I , through the heater wire.

The transient conditions may be studied with an oscilloscope. Time constants of the order of 0.1 ms are obtained by using 0.0025 mm diameter platinum and tungsten wires.

29.42.4. Flow Meter using Thermistors.

Flow can be measured by using two thermistors connected in two separate arms of a bridge circuit as shown in Fig. 29.80. One thermistor is sealed in a cavity in a brass block and the other thermistor is mounted in a small pipe. When air flows through the pipe, the temperature of the thermistor (placed inside the pipe) decreases because of conduction of heat. This thermistor is thus cooled, and its resistance increases which unbalances the bridge causing a current to flow through the meter. The amount of cooling is proportional to the rate of flow of air and the meter may be calibrated to read directly the rate of flow in the pipe.

This instrument can be designed to measure flows as low as $15 \times 10^{-12} \text{ m}^3/\text{s}$. The instrument can measure flow rates over a range of 100,000 : 1 by switching the resistance in series with the output meter.

When the sensing thermistor of the flowmeter is placed in free air, the instrument becomes an anemometer which measures velocity of air. It can be calibrated to measure velocities of air from light breeze to supersonic speeds.

Example 29.34 An electromagnetic flowmeter is used to measure the average flow rate of an effluent in a pipe of 50 mm diameter. The velocity profile is symmetrical and can be assumed uniform. The flux density in the liquid has a peak value of 0.1 Wb/m^2 , the output from the flow meter electrodes is taken to an amplifier of gain 1000 and impedance between the electrodes is $250 \text{ k}\Omega$.

(a) Determine the effluent average velocity when the peak to peak voltage at the amplifier output is 0.2 V.

(b) Given that the effluent conductivity decreases by 20 percent with the same flow rate, determine the percentage change in reading at the amplifier output.

Solution : (a) Peak to peak voltage at amplifier output = 0.2 V.

Peak voltage at amplifier output = $0.2/2 = 0.1 \text{ V}$.

This is the voltage under loaded conditions.

From Eqn. 2.18 page 24, we have

$$\text{Voltage under loaded conditions } e_{0L} = \frac{e_0}{1 + Z_0/Z_L}$$

or peak open circuit voltage $e_0 = e_{0L}(1 + Z_0/Z_L) = 0.1(1 + 250 \times 10^3/2.5 \times 10^6) = 0.11 \text{ V}$.

The peak open circuit voltage at the amplifier output terminal is : $e_0 = B l v \times \text{gain}$

$$\therefore \text{Average flow rate } v = \frac{0.11}{0.1 \times 50 \times 10^{-3} \times 10^3} = 0.022 \text{ m/s.}$$

(b) The effluent conductivity decreases by 20 per cent and therefore its impedance increases

to :

$$Z_0 = 1.2 \times 250 \times 10^3 = 300 \times 10^3 \Omega = 300 \text{ k}\Omega.$$

Therefore, for the same flow rate, the peak to peak voltage of the amplifier under loaded conditions

$$= \frac{2 \times 0.11}{(1 \times 300 \times 10^3 / 2.5 \times 10^6)} = 0.1964 \text{ V.}$$

$$\text{Percentage decrease in voltage} = \frac{0.2 - 0.1964}{0.2} = 1.78\%.$$

MEASUREMENT OF LIQUID LEVEL

29.43. Electrical Methods

The direct conversion of liquid level position to electrical signal is used in many instances. The measurement is generally done by two conversions, so that the liquid level is determined indirectly. The first conversion usually is liquid level to a displacement through a float in a liquid or a spring loaded plate in contact with the surface in the case of granular solids. This displacement is then converted into an electrical signal by a secondary transducer connected to float or plate. There are, however, many applications where this is not possible and hence other methods like optical or acoustic means or gamma rays are used.

The electric transducers used for level measurements are :

(i) Resistive, (ii) Inductive, and (iii) Capacitive.

29.43.1. Resistive Method. This method uses mercury as a conductor as shown in Fig. 29.81. A number of contact rods are placed at various liquid levels. As head h increases, the rising level of mercury above the datum, shorts successive resistors R and increases the value of current. The ammeter used may be calibrated to read the value of h directly.

Advantages

1. Where there is a need for a fairly continuous record of the level, more and more contact rods can be added, with separate signal outputs for each contact rod. The signal can be used for indication and also for initiating some control action to actuate valves or pumps as well as warning lights and alarms depending upon the level.

2. The system uses low voltage to eliminate danger to the operators and to prevent arcing at the contact points.

3. The signal can be transmitted to any desired point.

4. These transducers can be used in pressurized containers without packing glands or shafts.

5. The unit is simple to calibrate since the distance between the levels of contact rods can be accurately measured and the indicated value may be checked for each measured value.

Disadvantages

1. Due to arcing at the contact points, it is not safe to use this transducer in explosive atmosphere.

2. In order to have a stepless indication of the liquid level, an extremely large number of contact rods are needed.

3. The contact rods are corroded by corrosive liquids. In addition, the electric charges promote corrosion.

4. These systems also present difficulties when there is saturated vapour above the liquid phase.

5. Any changes in the conductivity of the liquid causes serious errors.

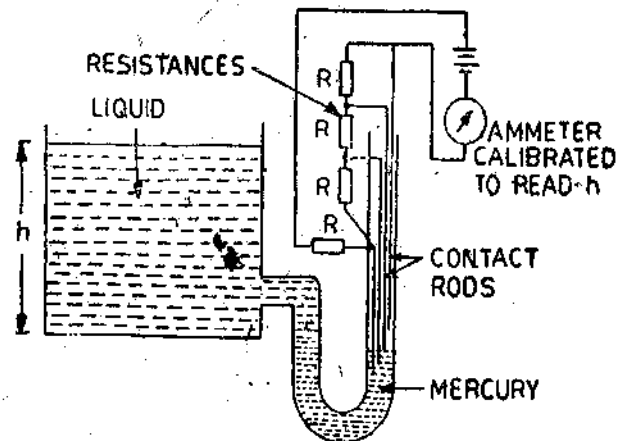

Fig. 29.81. Measurement of level of liquids by resistive method.

29'43'2. Inductive Methods. The inductive level transducers are mainly used for measurement of level of conductive liquids employing variable permeability method. The arrangement shown in Fig. 29'82 uses two coils L_1 and L_2 wound around a steel tube containing the liquid. The coils are connected in series through a resistance and the circuit is energized by an alternating current source. The inductance of each coil is initially equal say about 250 μ H. One coil say L_1 acts as the search coil. It can be set at a predetermined level. The inductance of the search coil changes rapidly as the conducting liquid moves into the plane of the coil. The method works well because the tape material is weakly magnetic and the liquid metal is a conductor which allows eddy currents to flow in it. The relationship between the output voltage and the liquid level is essentially non-linear.

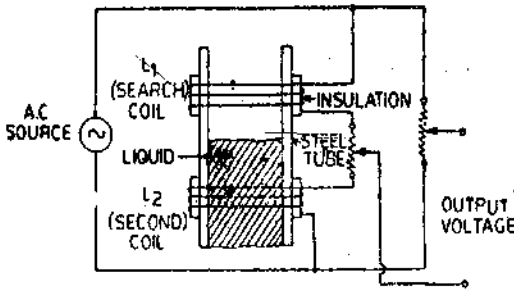

Fig. 29'82. Measurement of liquid level with variable permeability method.

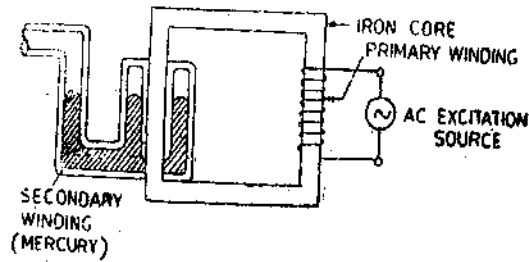

Fig. 29'83. Liquid level determination by loading of secondary winding.

Another method uses the loading of secondary winding of a transformer. This method is applicable to good electrical conducting materials like mercury. This is shown in Fig. 29'83.

A coil is wound round one core of a two limbed transformer. The mercury column surrounding the iron core forms the secondary of the transformer. The resistance of the secondary winding depends upon the height of the mercury column and therefore the power consumption as monitored on the primary side is indicative of the liquid level.

29'43'3. Capacitive Methods

1. Variable Area Method. The variable area capacitive transducer is used for measurement of levels of both solids and liquids. The electrical conducting container containing the materials is used as one connection point of the transducer. The other point is a metal rod completely covered by insulating material inside the container. The insulating material acts as the dielectric medium and the capacitance varies linearly with the height of the material.

The relationship is given by:
$$C = \frac{2\pi\epsilon h}{\log_e(d_2/d_1)} \text{ F}$$

where ϵ = permittivity of the insulator ; F/m, h = height of material ; m,

d_1 = diameter of the metal rod ; m, and d_2 = external diameter of the insulator ; m.

The container should be earthed to avoid any danger of electric shock to the personnel and to prevent any errors due to external metallic objects.

2. Capacitive Voltage Divider Method.

In case, the conductivity of a liquid is high, its surface can be used as one electrode of the capacitor. The other electrode is a fixed reference plate parallel to the surface of the liquid. A system incorporating these features is shown in Fig. 29'84. This uses an auxiliary electrode P_1 placed at a fixed distance above the reference electrode P_2 . The two electrodes P_1 and P_2 are electrically insulated from each other. An a.c. voltage is applied between the liquid and the electrode P_1 .

Potential of electrode P_2 with respect to earth
$$E_0 = E_A \frac{C_1}{C_1 + C_2} \text{ V}$$

Capacitance C_2 is inversely proportional to the distance between the liquid surface and P_2 . Thus the output voltage decreases with rise of liquid level and therefore the relationship between them is non-linear.

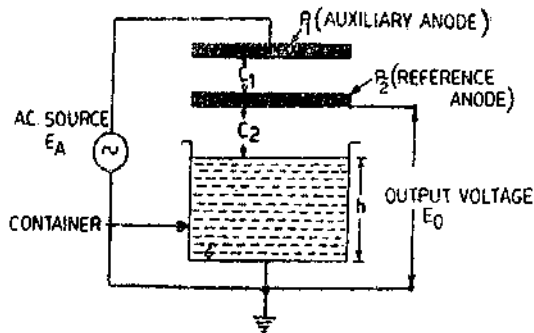

Fig. 29'84. Capacitive voltage divider method for measurement of level of high conductivity liquid.

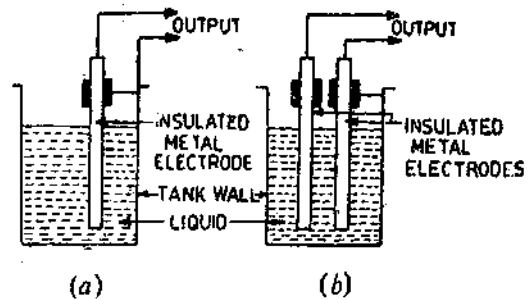

Fig. 29'85. Measurement of liquid level using capacitive transducers.

3. **Variable Dielectric Constant Method.** If the liquid is non-conducting it can be used as a dielectric in a capacitor. Art. 25'31 5 on page 800 explains the measurement of liquid level with variation of dielectric constant.

The arrangements for measurement of liquid level for non-conducting liquids are explained below :

Fig. 29'85 (a) shows an insulated metal electrode firmly fixed near and parallel to the metal wall of the tank. If the liquid is non-conductive, the electrode and the tank wall form the plates of a parallel plate capacitor with the liquid in between them acting as the dielectric. If the liquid is conductive the rod and the liquid form the plates of the capacitor, and the insulation between them is the dielectric.

The capacitance of this capacitor depends, among other factors, upon the height of the dielectric between the plates. The greater the height, the greater the capacitance. The lesser the height, the smaller is the capacitance. Thus, the capacitance is proportional to the height of the liquid in the tank.

Where the tank is not of metal, two parallel insulated rods (electrodes), kept at a fixed distance apart are used as shown in Fig. 29'85 (b). The two rods act as two plates of a parallel plate capacitor. The higher the liquid level, the greater is the capacitance.

The capacitance in the above cases may be measured and this measured capacitance is an indication of liquid levels.

29'43'4. Measurement of Liquid Level with Gamma Rays

Gamma rays are being increasingly used for detection of liquid levels. A source of gamma rays is placed at the bottom of the tank. A sensor of gamma rays like a Geiger Müller tube is placed outside the tank near the top. (See Fig. 29'86)

As the gamma rays can penetrate the tank walls, the tube senses the rays and greater the intensity of other rays, the greater will be the output of this tube. Now the intensity of the rays will depend upon the liquid level. Maximum radiation will reach the Geiger Müller tube if the tank is empty. But if there is some liquid in it, some of the rays will be absorbed by the liquid and the radiations reaching the tube will be small, and hence its output is small. The higher the level of the liquid, the greater is the absorption and hence lesser will be the output of the Geiger Müller tube. Thus the output of the Geiger Müller tube is inversely proportional to the liquid level. The output of the Geiger Müller tube is in the form of pulses which may be counted by a counter. Thus the counter may be directly calibrated in terms of the liquid level.

29'43'5. Ultrasonic Method

An ultrasonic transmitter receiver can be mounted on the top of tank for measurement of level of either solids or liquids as shown in Fig. 29'87. The beam is projected downwards by the transmitter and is reflected back by the surface of the solid or liquid contained in the tank. The beam is received by the receiver. The time taken by the beam is a measure of the distance travelled

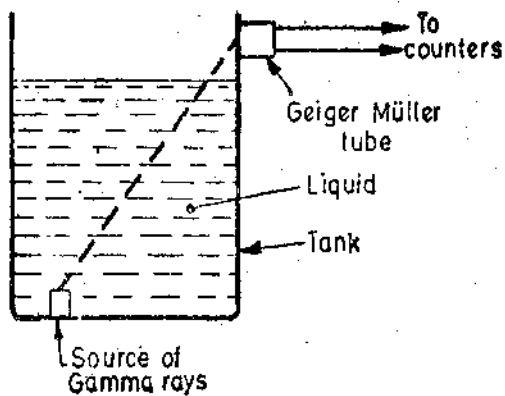

Fig. 29'86. Measurement of liquid level using Gamma rays.

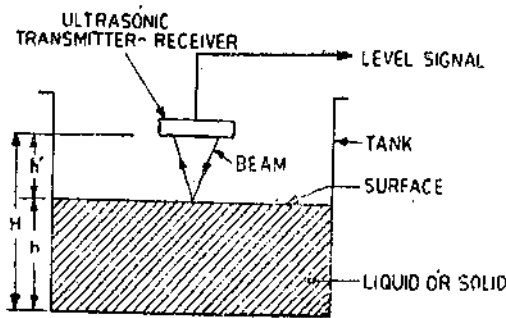

Fig. 29'87. Measurement of level by ultrasonic method.

by the beam. Therefore, the time 't' between transmitting and receiving a pressure pulse is proportional to the distance 'h' between the ultrasonic set and surface of the contents of the tank.

or $t \propto h \propto (H-h)$

Since distance H between ultrasonic set and the bottom of the tank is fixed, time 't' is measure of level 'h'.

29'43'6. Measurement of Liquid Level using Float

A float operated voltage potential divider is shown in Fig. 29'88. As the liquid level rises in the tank, the float, which is generally a hollow ball, is raised. Its arm causes the wiper to move over the potential divider whose output terminals are connected to a voltmeter. As a float rises, a greater part the potential divider is included in the output circuit giving an increased output voltage.

∴ The output voltage V is proportional to the liquid level h.

The output terminals from the potential divider may also be taken to a remote location for display and control.

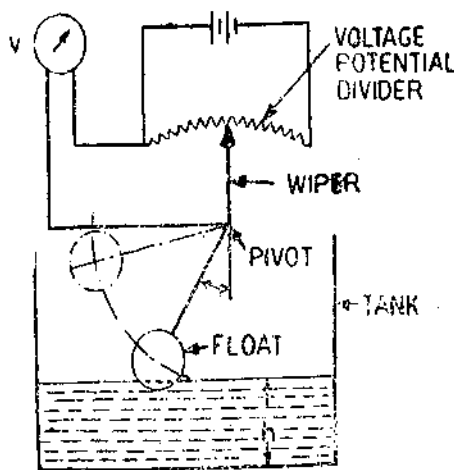

Fig. 29'88. Float operated voltage potential divider for liquid level measurements.

MEASUREMENT OF THICKNESS

29 44. Electrical Methods The electrical methods of measuring thickness are : (i) Resistive, (ii) Inductive, (iii) Capacitive, (iv) Ultrasonic, and (v) Nuclear.

29 44.1 Inductive Methods Inductive methods of thickness measurement use : (i) reluctance variation transducers, and (ii) eddy current transducers. Fig. 29'89 (a) shows the measurement of thickness of a magnetic material using a reluctance variation transducer. This transducer has a U shaped magnetic core over which a coil is wound. The test piece completes the magnetic circuit. Inductance of the coil depends upon the reluctance of the magnetic circuit. The reluctance, in turn, depends upon the thickness of the test piece. Higher the thickness, lower is the reluctance and higher is the inductance. Therefore, the inductance of the coil provides a measure of the thickness of the magnetic test piece.

The thickness of non-magnetic materials can also be measured by the reluctance variation transducer. The non-magnetic material is deposited or placed on a magnetic base as shown in Fig 29'89 (b). The ferromagnetic base is so thick that the reluctance of the magnetic circuit is determined by the distance between the ends of the U core and the base plate, i.e., by the thickness of the test piece. An increase in thickness causes an increase in reluctance and a decrease in inductance. Thus by measuring inductance, the thickness can be known.

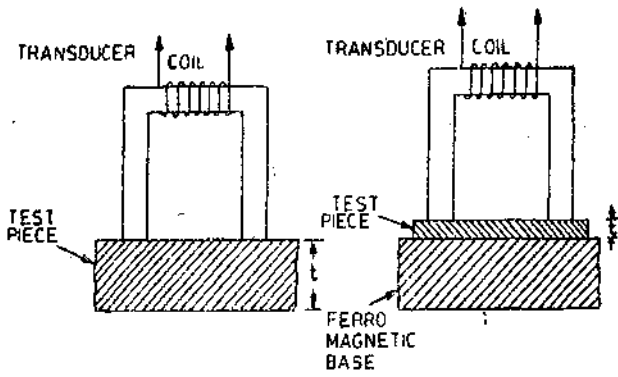

(a) Magnetic material

(b) Non-magnetic material

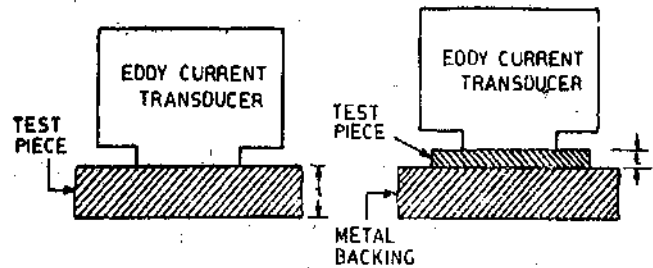

(a) Non-magnetic conducting material

(b) Non-magnetic non-conducting material

Fig. 29'89. Measurement of thickness using reluctance variation transducer

Fig. 29'90. Measurement of thickness using eddy current transducers.

The measurement of thickness of conducting and non-conducting materials using eddy current transducers is shown in Figs. 29'90 (a) and (b). The eddy current transducer used for measurement of thickness of non-magnetic but conducting materials consists of a coil wound on an insulated core. The coil is excited by an alternating current supply. The alternating magnetic field produces eddy currents in the test piece or its backing. The magnetic field produced by eddy currents opposes the magnetic field of the coil and therefore the inductance of the coil is reduced. This system is suitable for measurement of thickness of both magnetic and non-magnetic materials, as well as non-conducting coatings like paints on a metal backing. In the case of conducting material as shown in Fig. 29'90 (a), the higher the thickness of test piece, higher will be the eddy currents and lower would be the inductance of the coil.

The measurement of thickness of a non-conducting material is done by depositing it on a metal backing. If the thickness of the non-conducting test piece is large, the eddy current transducer head and the metal backing are separated by a larger distance and therefore the eddy currents are small and consequently the inductance of the coil is large.

Metal coatings of thickness as low as 50 or 75 nm and aluminium films down to a thickness of 125–500 pm can be measured with the help of eddy current transducers.

29'44'2. Capacitive Method

If the material is being tested is an insulator, capacitive method using an arrangement shown in Fig. 29'91 may be used. Two metal electrodes are placed on the two sides of the insulating material being tested. This arrangement forms a parallel plate capacitor, the two electrodes acting as the two plates with the insulating material acting as the dielectric. The capacitance, naturally depends upon the thickness of the insulating material under test. Thus by measuring the capacitance of this arrangement, the thickness of the insulating material may be determined.

29'44'3. Measurement of Thickness using Ultrasonic Vibrations. Ultrasonic vibrations are mechanical vibrations employing a gas, liquid or solid as medium, and whose frequencies are above the audio frequency range. These vibrations are produced by a transducer which converts the electrical output of an oscillator to ultrasonic vibrations of corresponding frequencies.

There are two types of such transducers :

(i) Magnetostrictive type, and (ii) Piezoelectric type.

1. Magnetostrictive Type. This consists of magnetic rod placed in coil. The coil is excited by an oscillator. The alternating field produces deformations in the magnetic rod, making it longer and shorter alternatively. This results in corresponding vibrations produced in a medium nearby (say air).

2. Piezoelectric Type. This transducer is more commonly used. When a voltage is applied to a piezoelectric crystal, it becomes mechanically deformed. Thus when alternating voltage from an oscillator is applied to it, the piezoelectric crystal changes its shape alternately in one direction and then in the other at the frequency of the oscillator. In this way, ultrasonic vibrations are produced.

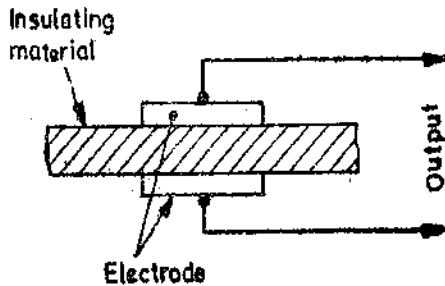

Fig. 29'91. Measurement of thickness of insulating materials.

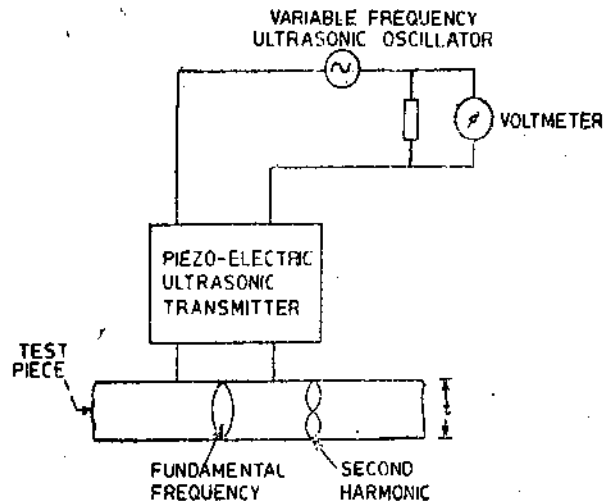

Fig. 29'92. Measurement of thickness by ultrasonic transducer.

The way ultrasonic vibrations are used to measure thickness is shown in Fig. 29'92. The transducer is placed on top of the test piece, and the ultrasonic vibrations pass through it. When the frequency of the oscillator is varied and standing waves are set up at certain frequencies. The value of these frequencies depend upon the thickness of the test piece. The setting up of standing waves is indicated by a sudden sharp rise in power absorbed from the transducer. Thickness $t = c/2f$ where c is the velocity of sound in the test piece, and f is the lowest frequency at which standing waves occur.

Ultrasonic method can be used for measurement of thickness of steel ranging from 3 mm to 30 cm.

29'44'4. Nuclear Radiation Methods. Nuclear radiation methods use either alpha, beta, gamma or X-rays as radiation obtained from radioactive sources. The radiation source is shielded all around except in the direction of the detector. A radiation detector such as a Geiger Müller tube ionization chamber or a scintillation counter explained in Arts. 29'51, 29'52 and 29'53) are used for measuring the amount of radiation reaching the detector.

A method using X-rays for measurement of thickness is shown in Fig. 29'93. The X-ray source radiates to two detecting cells through a sheet of known thickness and through a similar sheet whose thickness is to be measured. The detecting cells are electron multiplier cells modified to respond to X-rays only. When the thickness of the two sheets *i.e.* the thickness of sheet of known thickness and the thickness of the sheet under test are equal, the amplifier input is zero and hence the indicating instrument reads zero. (The indicating instrument is a centre zero instrument). The indicating instrument may be directly calibrated in terms of the relative thicknesses of the two sheets.

The advantages of using X-ray system are :

(i) It measures thickness without contact with the material under test.

(ii) This method is well-suited to measurement of thickness of sheets in rapid motion like in rolling etc.

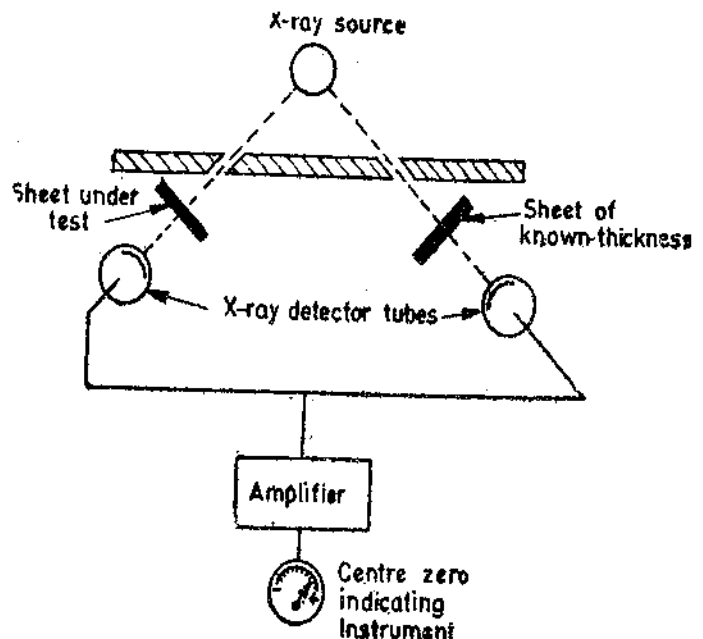

Fig. 29'93. Measurement of thickness using X-ray methods.

Gamma and X-rays are normally used for heavy metals and thick test pieces. Beta rays are

used for thin metal sheets or foils, paper, rubber and plastics. Alpha rays are used for very thin foils whose thickness is of the order of nm.

Beta, Gamma and X-rays may be used in the examination of hidden flaws in castings. In this case, the penetration power of different X-rays may be used advantageously.

MEASUREMENT OF HUMIDITY

29'45. Humidity. Humidity is the measure of water vapour present in a gas. It is usually measured as absolute humidity, relative humidity or dew point temperature.

Absolute Humidity. It is the mass of water vapour present per unit volume.

Relative Humidity. It is the ratio of water vapour pressure actually present to water vapour pressure required for saturation at a given temperature. The ratio is expressed in percent. Relative humidity (RH) is always dependent upon temperature.

29'45'1. Hygrometers. A hygrometer measures the value of humidity directly. Generally, the output of a Hygrometer is used to indicate relative humidity.

Several materials exhibit changes in electrical properties that are caused by humidity. These are frequently used in transducers that are designed and calibrated to read relative humidity directly.

1. Resistive Hygrometer. Some hygroscopic salts exhibit a change in resistivity with humidity. The most common is lithium chloride. This, with a binder, may be coated on a wire or on electrodes. Resulting resistance changes cover a wide range, e.g. 10^4 to $10^9 \Omega$ as the humidity changes from 100 to 0 per cent. This makes it impractical to design a single element to operate from 1 to 100 percent relative humidity. Instead several elements are used, each in a narrow range, with provision for switching elements. Resistance is measured either with a Wheatstone bridge or by a combination of current and voltage measurements.

Most of these must not be exposed to conditions of 100 percent humidity as the resulting condensation may damage the device. Either they must be operated in a constant temperature environment or temperature corrections must be made. These are accurate to within ± 2.5 per cent or ± 1.5 percent in some cases. Response times are typically of the order of a few seconds. These are currently the most common electronic hygrometers.

A typical resistive hygrometer is shown in Fig. 29'93. It shows a mixture of lithium chloride and carbon which acts as conducting film. This is put on an insulating substrate between metal electrodes.

The resistance of the element changes when it is exposed to variations in humidity. The higher the relative humidity, the more moisture the lithium chloride will absorb, and the lower will be its resistance.

The resistance of the sensing unit is a measure of the relative humidity. Resistance should be measured by applying a c. to the Wheatstone bridge. D.C. voltage is not applied because it tends to breakdown the lithium chloride to its lithium and chlorine atoms. The current flow is a measure of the resistance and hence of the relative humidity.

2. Capacitive Hygrometer. Some hygroscopic materials exhibit a change in dielectric constant with humidity changes. In addition, the presence of water vapour in air changes the dielectric constant of the mixture. In either case, the changes are small, and the change in capacitance is usually measured by including it as the frequency-determining element in an oscillator, heterodyning this signal with a beat frequency oscillator, and measuring the resulting difference frequency. These transducers have response time of about 1 s.

3. Microwave Refractometer. For secondary standards, a system consisting of two cavities, each of which is coupled to a klystron, may be employed. One cavity contains dry air, the other contains the mixture to be measured. The change in dielectric constant changes the frequency of

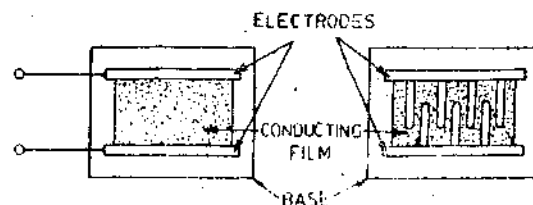

Fig. 29'93. Resistive hygrometer.

one oscillator. This difference is measured electronically. The complexity of the devices precludes their use except in very special situation.

4. **Aluminium oxide Hygrometers.** The aluminium-oxide coating on anodized aluminium exhibits a change in dielectric constant and a change in resistivity with a change in humidity. A hygrometer that uses this is built by using the base aluminium as one electrode and depositing a very thin electrode—usually gold—on the opposite side of the oxide as shown in Fig. 29'94.

This thin electrode is porous to the air-vapour mixture. The resulting changes in resistivity and capacitance lead to a complex impedance changes, which is measured with a bridge or related methods. Errors are less than ± 3 per cent and response times are about 10 s. The changes are large, but often only one sensing element is needed for the entire range to be covered. This hygrometer is rapidly becoming a very important component in electronic systems.

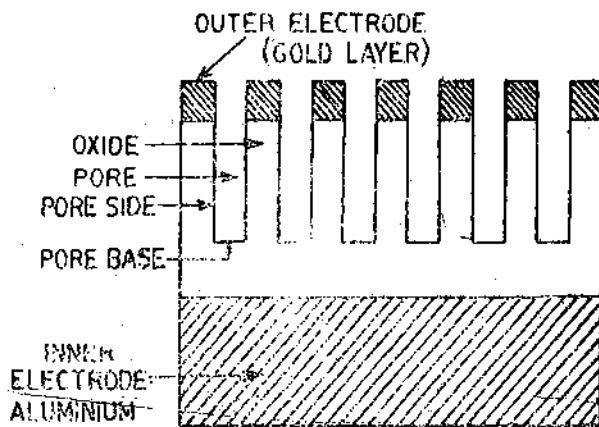

Fig. 29'94. Aluminium oxide hygrometer.

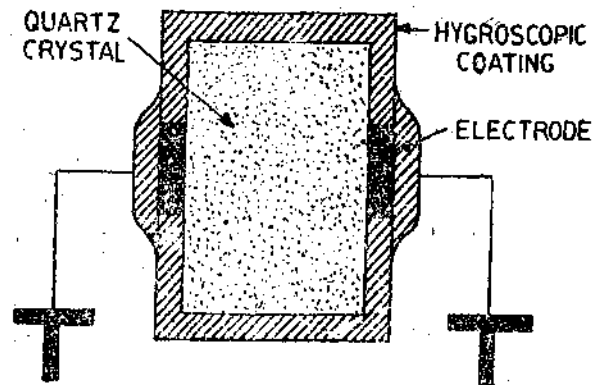

Fig. 29'95. Crystal hygrometer.

5 **Crystal Hygrometer** Some crystals are hygroscopic, and others may be coated with a hygroscopic material. The coating materials are hygroscopic polymers. The crystals are used as frequency determination elements in electronic oscillators. Frequency shifts with humidity as the mass of the crystal changes with amount of water absorbed by coating are measured electronically. These transducers are useful if a telemetry system is needed because the frequency range can be chosen as a standard telemetry frequency.

A crystal hygrometer using quartz is shown in Fig. 29'95.

MEASUREMENTS OF SOUND USING MICROPHONES

29'46. Microphones

A microphone is a special type of pressure transducer converting acoustic energy—pressure waves—into electrical energy for measurement. Invariably the sensing element is a diaphragm. A variety of transduction elements are available. The range of pressure to be measured is normally small compared with ambient (atmospheric) pressure, even for the most intense sounds. Desirable characteristics include linearity over a wide range of amplitudes and frequencies. Directional patterns must be considered. Sound pressure levels are commonly expressed in db.

The commonly used pressure reference being $20 \times 10^{-5} \text{ N/m}^2$.

This reference corresponds to the lowest audible sound in a normal human ear. A pressure of 90 db or 0.632 N/m^2 is normally the maximum sustained level human beings can tolerate (threshold of pain).

The sensitivity of a microphone is a measure of the voltage developed per unit sound pressure. It is given by :

$$\text{Sensitivity (db)} = 20 \log_{10} (\text{voltage output}) + 74 \text{ db (applied sound pressure in db)}$$

Thus a sensitivity of -20 db means that a voltage of 0.1 V will be developed by a sound signal of pressure level 74 db which is the reference condition of sensitivity.

29'46'1. Types of Microphones

1. **Carbon Microphones.** The moving diaphragm is mounted so as to compress together grains of carbon, thus changing the resistance in a circuit. The device is externally powered from a constant-voltage source and the resulting current is thus a function of the sound pressure. The most common application of these is in telephones. Their frequency range is limited to a maximum of about 5 kHz. The output impedance is low, and the sensitivity is high, about -40 db. These find little application in the field of sound measurements.

2. **Capacitive Microphones.** The moving diaphragm is used as one plate of the capacitor. A constant charge is maintained on the plates from a 200 to 500 V supply. The changes in capacitance cause a change in the capacitor voltage. An emitter-follower is usually located close to the microphone, reducing the inherently high output impedance and reducing the distortion caused by noise. These are expensive, but accurate, instruments. They are used for precision measurements, and as standards. Their frequency range is up to 50 kHz and are reasonably sensitive. A typical sensitivity is -50 db. The high voltage supply, however, is often inconvenient to provide.

3. **Dynamic Microphones.** These microphones use the electromagnetic transduction principle. A dynamic microphone is shown in Fig. 29'96. An a.c. voltage is generated when a coil is moved in a magnetic field. A membrane is mechanically linked to a moving coil surrounded by a permanent magnet. The membrane and the coil are suspended so that they can move back and forth. The sound pressure waves force the membrane towards the magnet, moving the coil across the magnetic field. The voltage developed across the coil terminals is a direct result of the motion of the coil, which clearly depends upon the force of pressure waves. They are self-generating and have low sensitivity, typically -80 db and a low output impedance. Their frequency response is limited to about 20 KHz. These find field application but are seldom used in precision measurements.

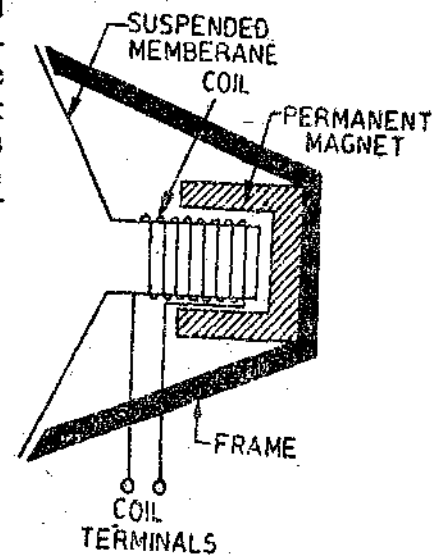

Fig. 29'96—Dynamic Microphone.

4. **Inductive Microphones.** The diaphragm causes changes in the magnetic properties of certain materials. In turn these changes appear as changes in dimensions, which are sensed by displacement transducers. These have low output impedance, low sensitivity (-100 db), and operate in the ultrasonic region. They find application in underwater transducers.

5. **Piezoelectric Microphones.** These self-generating microphones have been developed for use in a wide variety of situations. The problems of piezoelectric devices in general apply. These problems include high output impedance, temperature dependance, and vibration sensitivity. Microphones built with this transduction element have a frequency response extending to the ultrasonic region, above 100 kHz, and they have a low sensitivity -50 to -100 db. They also are very linear over a wide range of amplitudes and are widely used in sound measurement systems.

CHEMICAL SENSORS

29'47. Measurement of pH Value

Many industrial processes require that the acidity or alkalinity of solutions be measured and controlled if the process is to proceed effectively and efficiently. The degree of acidity or alkalinity of aqueous solution is determined by the relative concentrations of hydrogen and hydroxyl ions in the solution.

When the hydrogen ions predominate, the solution is acidic. Where the hydroxyl ions are in the majority, the solution is alkaline. Since the product of the hydrogen ion and hydroxyl-ion concentration in any such solution has a constant value, measurement of the hydrogen-ion concentration indicates not only the acidity of a solution but its effective alkalinity as well.

The dissociation constant is the product of hydrogen (H^+) ions and hydroxyl (OH^-) ions and this product is always equal to 10^{-14} .

Hydrogen ion concentration is measured on a scale called pH scale.

pH value of a solution is defined as the negative logarithm of the hydrogen ion concentration or

$$pH = -\log_{10} (H^+)$$

This scale ranges from 0 to 14.

For example suppose the hydrogen ion concentration is 10^{-14} . Therefore, hydroxyl ion concentration is 10^0 as the product of two has to be 10^{-14} . The pH value for such a solution is : $pH = -\log_{10} (10^{-14}) = 14$. On the other hand, suppose the hydrogen ion concentration is 10^0 . This means that the pH value for this solution is : $pH = -\log (10^0) = 0$

Therefore the hydrogen ion concentration can be measured on a pH scale which varies from 0 to 14. In a neutral solution, the concentrations of both hydrogen and hydroxyl ions are equal *i.e.*, both are 10^{-7} . Therefore, for a neutral solution : $pH = -\log (10^{-7}) = 7$

Thus a neutral solution like pure water has a pH value of 7.

Supposing the solution is acidic. Therefore the hydrogen ion concentration is more. Suppose it is 10^{-5} and therefore the hydroxyl ion concentration is 10^{-9} .

The pH value for this solution is : $pH = -\log_{10} (H^+) = -\log_{10} (10^{-5}) = 5$.

Thus for acidic solutions the pH value lies between 0 to 7. In case of alkaline solution the pH value is between 7 to 14.

For alkaline solutions the hydroxyl ion concentration is more. Supposing hydroxyl ion concentration is 10^{-2} and hence the hydrogen ion concentration is 10^{-12} . The pH value for this solution is : $pH = -\log_{10} (10^{-12}) = 12$.

Thus we conclude that hydrogen ion concentration is measured on a scale (the pH scale) that ranges from 0 to 14. On this scale neutrality is 7, the value obtained when the hydrogen and hydroxyl-ion are equal and balance each other, as is the case with pure water. As the solution becomes more acidic, its pH scale reading decreases below 7. As the solution becomes more alkaline, its pH scale reading increases above 7.

The measurement of pH value is obtained by immersing a pair of electrodes into the solution

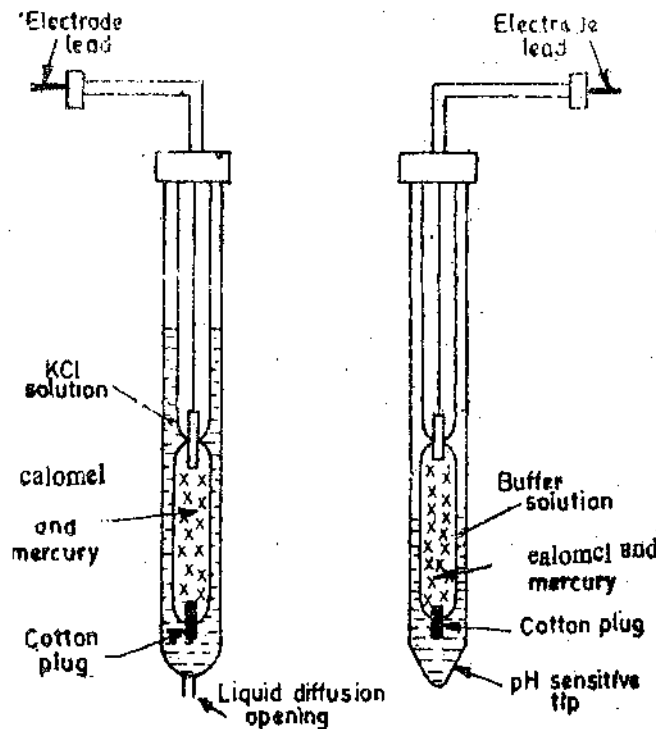

(a) Reference electrode. (b) Measuring electrode.

Fig. 29'97. pH cell.

to be measured and measuring the voltage developed across them. The action is somewhat similar to that of a voltaic cell where a pair of dissimilar electrodes are immersed into an electrolyte.

In the pH cell, one of the electrodes, called the **reference electrode**, is at a constant potential regardless of the pH value of the solution under test. The potential of the other electrode, called the **measuring electrode**, is determined by the pH value of the solution. Thus the potential difference between the two electrodes depends upon the pH value of the solution.

The reference electrode [See Fig. 29'97 (a)] is made of glass and consists of an inner assembly containing a solution of calomel (mercury chloride) and mercury. This assembly is surrounded by a larger glass tube, and the space between the two contains an accurate solution of potassium chloride (KCl). A tiny opening in the bottom of the electrode permits the potassium chloride to diffuse very slowly into the solution under test. In this way, electrical contact is made between this solution and the calomel solution of the electrode.

The measuring electrode (also known as the *glass electrode*) is somewhat similar to the reference electrode [See Fig. 29'97 (b)]. However, the mercury calomel element is surrounded by a buffer solution of constant pH. The bottom of the outer tube has no opening. Instead, it tapers down to a tip made of thin glass of special composition. At this tip a potential difference is developed between the buffer solution and the solution under test because of the difference in the pH value of the two solutions. Since the pH value of the buffer solution is constant, the net potential of this electrode is a function of the pH value of the solution being tested.

Both electrodes are mounted to form an assembly that is inserted into the solution. The difference of potential between the electrodes, which is a function of the pH value of the solution under test, may be measured by a voltmeter calibrated, in units of pH value or, after amplification, it may be employed to actuate some control device.

29'48. Measurement of Thermal-conductivity (Gas Analyzer). When the chemical purity of a gas is to be measured, the thermal conductivity gas analyzer is used. The operation of this type of analyzer is based on the vast difference in heat conductivity among gases. Fig. 29'98 shows the basic circuit for a thermal conductivity gas analyzer.

Note that a balanced bridge circuit is formed with two sensing resistors acting as balanced legs of the bridge. One sensing resistor is surrounded by the gas to be analysed, whereas the other resistor is surrounded by a reference gas (such as oxygen, pure atmosphere etc.). Where practical, both gases are maintained at the same pressure, water content, and so forth.

The bridge is first balanced by exposing both resistors to the same gas. Current flows through both sensing resistors, as well as through resistors *P* and *Q*. Resistor *Q* is adjusted for a

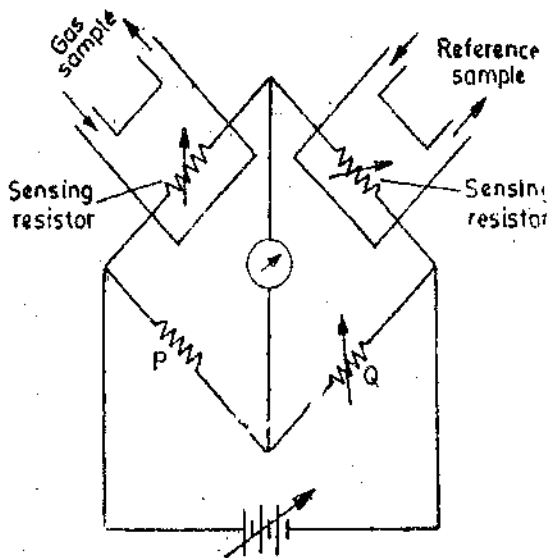

Fig. 29'98. Basic thermal-conductivity gas analyzer circuit.

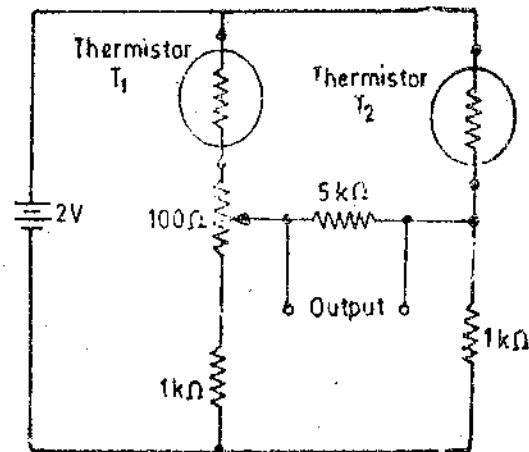

Fig. 29'99. Measurement of thermal conductivity with thermistors.

"balance" or "zero set" condition on the meter. Then the resistors are exposed to the reference sample and gas sample.

If the gas sample contains elements having a different thermal conductivity than the reference sample, the bridge will be unbalanced. In some cases, the meter reads out in terms of the thermal conductivity, whereas in other analyzers, the indication is on a *go-no go* or *good-bad* basis.

Measurement of Thermal Conductivity Using Thermistors. For this application two thermistors are connected in the adjacent arms of a Wheatstone bridge as shown in Fig. 29'99. The bridge supply is high enough to raise the thermistors above ambient temperature, typically to about 150°C. One thermistor is mounted in a static area to provide temperature compensation while the other is placed in the medium to be measured.

NUCLEAR INSTRUMENTATION

29'49 Introduction. A lot of instrumentation is needed to measure the amount of radioactivity encountered in nuclear research work and for tracking of radiated alpha, beta, and gamma particles. The energy of these particles is absorbed by other molecules, producing chemical changes, ionization, or other reactions that produce visual evidence of the presence of other particles. These processes are used to detect, count and trace the movement of such particles.

29'50. Types of Radiations. Radioactive materials emit nuclear radiations which mainly consist of four parts :

1. **Alpha Particles.** The alpha particle is a helium nucleus consisting of two protons and two neutrons. It has a mass of 6.2×10^{-27} kg and carries a positive charge of 3.2×10^{-9} C. The alpha particle is the heaviest and the slowest, travelling at speeds of from 1/10 to 1/100 of the velocity of light. Since it has the greatest mass and slowest speed, it is least penetrating. It penetrates about 0.02 mm of aluminium foil.

2. **Beta Particles.** The beta particle is an electron with a mass of 9.03×10^{-31} kg and a charge of 1.6×10^{-19} C. Since beta particle is much lighter than alpha particle and has a speed approximately equal to that of light, it can penetrate much farther than alpha particle—about 100 times the penetration of alpha particle.

3. **Gamma Particles** Gamma particles or gamma rays, are an electromagnetic radiation with a wavelength of approximately 0.03 to 3 angstrom. Gamma particles travel at the speed of light, and because of their shorter wavelengths, have very great penetrating power. Gamma rays can penetrate about 20 cm through a mass of lead.

4. **Neutrons.** The mass of the neutron is intermediate between that of alpha and beta particles, having the same mass as a proton. The speeds of neutrons may be high or low depending upon the source from which they are emitted. Because neutron has no charge it is very difficult to detect. However, its penetrating power is small.

The above mentioned properties and other properties of these particles must be considered in the methods and processes for their detection and measurement. In the following pages, a few methods of detection and measurement of the above mentioned particles are described.

29'51. Geiger Muller Tube. The Geiger Muller tube or simply Geiger tube are frequently used for detection and measurement of alpha, beta and gamma rays. This tube is a diode, consisting of a cathode which is a long metal cylinder and an anode which is a fine wire running through the centre of the cylinder. Both of them are mounted in a thin walled, air tight, glass envelope, sealed by an extremely thin window through which radiations may pass at one end (See Fig. 29'100). The air is evacuated from the envelope and a small amount of an inert gas, such as Argon, is added.

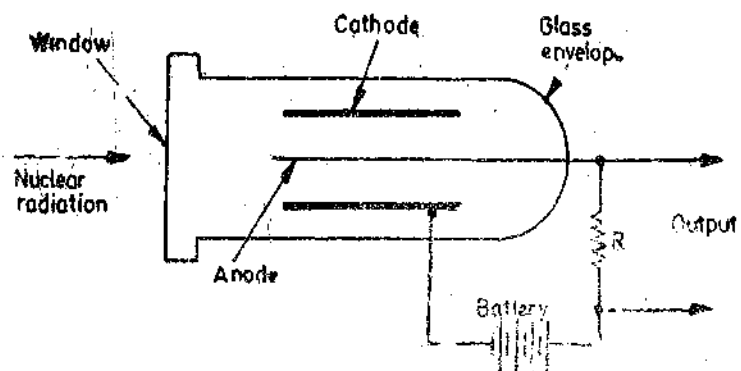

Fig. 29'100. Geiger Muller tube.

The voltage of the battery is kept

below the ionization potential of the gas. Now if radiation penetrates through the window and enters the envelope, it would ionize some of the gas atoms. The resulting negative ions go towards the anode and positive ions towards the cathode. In their passage, the ions collide with some of the gas atoms, causing them to be ionized in turn. This process continues till whole of the gas atoms are ionised. In fact complete ionization takes place in no time. A pulse of current thus flows through the tube. This current flows through the resistance, R , which is connected in the anode circuit. The resulting voltage drop across R is the output voltage.

Once ionization is established, it is expected to continue indefinitely. However, since resistor R , which has a high resistance, is connected in series with the anode and the battery, when the gas ionizes a heavy current flows through resistance causing a large voltage drop. This voltage drop is sufficient to reduce the anode voltage below the ionization potential and therefore ionization ceases.

As long as the gas is not ionized no current flows through the resistance R and hence there is no output. Thus when the gas deionizes, the current ceases to flow through resistance R and so there is no output.

Now if radiation again enters the tube, the ionization starts and a current again flows through resistance R giving an output voltage. This way a series of alpha or beta particles or bursts of gamma rays, cause a series of current pulses to pass through the anode circuit of the tube and hence through resistance R . The output pulses from resistance R may be amplified and registered by a counting device. By counting the number of pulses, we can know the number of particles entering the Geiger Müller tube in a particular interval of time. The number counted gives the intensity of radiation. The pulses may be stored in some cases and the total count may be calibrated directly in terms of radio-activity.

The counting rate of this tube is seldom greater than 10^8 counts per second.

29'52. Ionization Chamber. This is quite similar to the Geiger Müller tube as shown in Fig. 29'101. The ionization chamber is a metal cylinder (the outer electrode) sealed at one end by a window. The other end of the cylinder is closed, and a metal rod (the centre electrode) protrudes outside the cylinder on this end.

The central electrode is grounded through resistance R . Resistor R has a very high resistance. A large positive potential is applied to the outer electrode. The chamber contains a gas which may be air, carbon dioxide, nitrogen, argon or methane.

The action of this ionization chamber is similar to that of Geiger Müller tube.

Let us consider that the chamber is filled with air. When a nuclear radiation enters the chamber through the window, some of the atoms of the air are ionized, the resulting ions travel

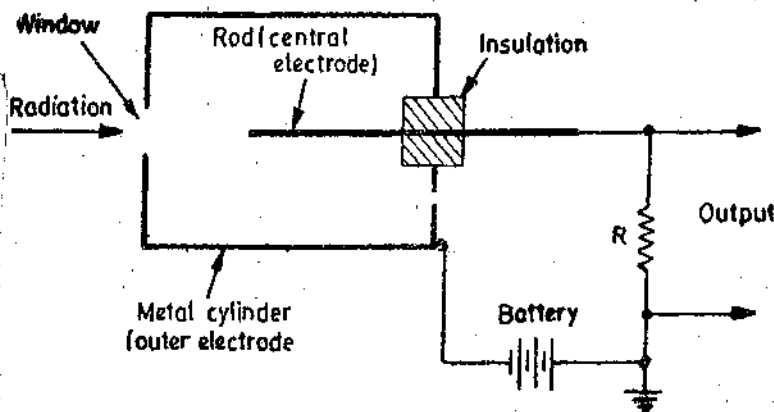

Fig. 29'101. Ionization chamber

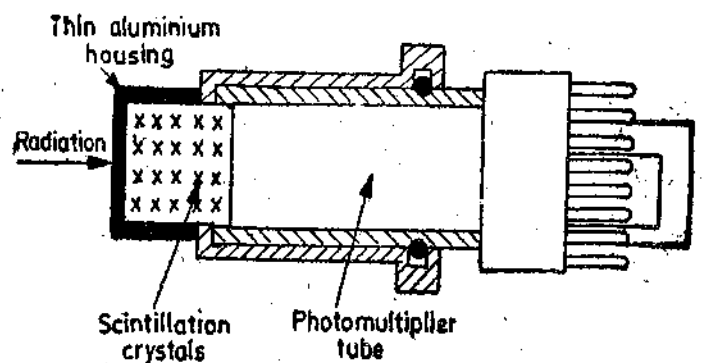

Fig. 29'102. Scintillation counter.

towards their respective electrodes *i.e.* positive ions towards the central electrode and the negative ions towards the outer electrode. In the process of rushing towards the electrodes, these ions collide with other atoms of air causing ionization of these atoms. The action is instantaneous.

As the positive ions collect on the central electrode (which is at ground potential), the d.c. potential of this electrode is increased. This increased potential, which is the output signal of the chamber, may then be amplified and measured. Since the increase in this potential is a function of the number of radiation particles that have entered the chamber, the intensity of the nuclear radiation may be determined. The main use of this chamber, is to detect and measure alpha particles.

29.53. Scintillation Counters. Certain crystals such as zinc sulphide, sodium iodide, anthracene and naphthalene etc., produce a brief flash of light each time they are struck by an alpha or beta or gamma particles. The production of a flash of light by striking the crystals mentioned above, with alpha or beta or gamma rays is called **Scintillation**.

This principle is employed in a nuclear radiation sensor called "Scintillation Counter".

The construction of a scintillation counter is shown in Fig. 29.102. Now every time a radiation strikes the scintillation crystals, a tiny flash of light is produced. The flash of light is amplified by a photomultiplier incorporated in the scintillation counter. Thus each particle produces a pulse of anode current at the output of the photomultiplier. The output of the photomultiplier is applied to a high speed electronic counter which counts each tiny flash generated by the scintillation crystals. Thus by counting the number of pulses in a given period of time, the intensity of radiation may be detected.

The advantages of a scintillation counter are :

(i) This is more sensitive than the Gieger Muller tube and hence can detect lower levels of radiation.

(ii) The crystals used in this device produce a flash of light when struck by X-rays. Hence this transducer may be used to detect X-rays as well.

(iii) Counting rate is very fast. Pulses of as short a duration as 2 ns may easily be recorded.

29.54. Solid State Ionization Sensing Elements. A system for counting the number of particles or photons whose energy level exceeds about 1,000 electron volt is built by using extrinsic semi-conductors mounted so that the radiation ionizes an atom in the crystal, and a pulse appears in the output circuitry. Operation is normally at liquid nitrogen temperatures. Counting rates as high as 10^6 per second are possible.

29.55. Detection of Neutrons. The neutrons do not carry any charge and hence are very difficult to detect. Thus we have to adopt indirect methods to detect them. Neutrons detecting methods require an arrangement where alpha or beta rays particles are produced by neutrons and these particles detected by the methods described above.

An indirect method of detection of neutrons is described below :

A neutron is made to strike the atom of a certain isotope of uranium. The uranium atom splits into two or more parts on account of fission. This releases, in the process, nuclear radiation in the form of alpha, beta and gamma rays, which may be detected by methods described above. Thus, by measuring the intensity of the radiations, the intensity of neutron beam producing them may be detected.

Only slow moving neutrons will produce fission of uranium atoms. Where fast moving neutrons are to be detected, a layer of paraffin is put on top of the uranium layer of detector. The paraffin converts the fast moving neutrons to the slow moving neutrons required for fission.

UNSOLVED PROBLEMS

1. A strain gauge having a resistance of 350 Ω and a gauge factor of 2 is connected in series with a ballast resistance across a 10 V supply. The ballast resistance is designed to give maximum sensitivity. The gauge is subjected to a dynamic strain of $(10 + 20 \sin 314 t)$ microstrain.

(a) Find the expression for the change in output voltage on account of strain.

(b) If a capacitor is connected in one output leads and if the voltage is read by a true rms reading voltmeter of infinite impedance, find the output voltage. [Ans. (a) $[50 + 100 \sin 314 t] \mu\text{V}$ (b) $70.7 \mu\text{V}$]

2. The resistance of a strain gauge is $R_0 = 120 \Omega$ and its gauge factor is 2. It is connected in a current sensitive Wheatstone bridge in which all resistances are 120Ω . The input voltage is 4 V. Calculate the detector current in μA for 1 microstrain. The resistance of the galvanometer is 100Ω .

Calculate the voltage output if 1 microstrain is applied to the gauge and the voltmeter has an infinite input impedance. [Ans. $9.1 \mu\text{A}$, $2 \mu\text{V}$]

3. A strain bridge uses a strain gauge of 100Ω resistance. Under no strain condition all the bridge arms have equal resistance. The resistance R_1 has to be change to a value $(20.56 \text{ (Fig. 29.5)})$ to obtain balance when the gauge is subjected to strain. The gauge factor is 2. Find the value of strain. [Ans. 0.0026]

4. A strain gauge having a gauge factor 2 is connected in a bridge circuit having an excitation voltage of 8 V. The resistances are all equal. It is subjected to a strain of 0.05. If this output is to represent $2/3$ of full scale deflection of a recorder, what should be the gain of the amplifier. The full scale input voltage of recorder is 1 V. [Ans. 28]

5. A single strain gauge of gauge factor of 2 is used in a Wheatstone bridge where each resistance is 120Ω . If the bridge exciting voltage is $8 \cos 1000 t$ and if the gauge is subject to sinusoidally varying strain of $300 \mu\text{m/m}$ peak value and a frequency of 10 Hz (i) find the equation for the output voltage as observed on a CRO (assuming infinite impedance for the CRO), (ii) reading of rectifier type voltmeter having an infinite impedance and using full wave rectification. Assume that the scale is calibrated in terms of average value of voltage. [Ans. (i) $1.2 \cos 1000 t \sin 10 \pi t \text{ mV}$ (ii) 0.76 mV]

6. A bridge circuit has two fixed resistors and two strain gauges all of which have a value of 120Ω . The gauge factor is 2.04 and strain applied to twin strain gauges, one in tension and the other in compression is 0.000165. If the battery current is 50 mA, determine the (i) voltage output of the bridge, (ii) the sensitivity in volt per unit strain.

If the galvanometer connected to output terminals reads $100 \mu\text{V}$ per scale division and if $1/10$ th of a division can be read with confidence, determine the resolution. [Ans. (i) 0.202 V , (ii) $1.225 \text{ mV}/\mu\text{g}$, $0.008 \mu\text{s}$]

7. In order to measure strain in a cantilever, two gauges are used one on top of the cantilever and the other at the bottom of the cantilever. The resistance of strain gauges is $1 \text{ k}\Omega$ each. The other two resistances in the circuit have resistance of 100Ω each. The bridge detector resistance is 100Ω and its sensitivity is $10 \text{ m}/\mu\text{A}$. Calculate the deflection of the galvanometer for 0.1% strain. The bridge supply voltage is 10 V. [Ans. 154 mm]

8. A gauge is made of a material having a resistance temperature co-efficient of $12 \times 10^{-4}/^\circ\text{C}$. It has a resistance of 120Ω and a gauge factor of 2. It is connected in a bridge circuit having resistances of 120Ω each. The bridge is balanced at ambient temperature. Supposing there is a change of 20°C in the temperature of the gauge. (a) Find the output voltage of the bridge if the input voltage is 10 V (b) What is the equivalent strain represented by change in temperature? [Ans. (a) 0.55 mV (b) $120 \mu\text{s}$]

9. Calculate the fractional change of resistance of strain gauge made of nichrome V material (a) due to a stress of 200 MN/m^2 in the metal to which it is bonded; (b) for a temperature change of 100°C when bonded to steel, (ii) when bonded to Duralumin. The modulus of elasticity for steel is 200 GN/m^2 while that for Duralumin is 70 GN/m^2 . The gauge factor is 2.5. The coefficients for linear expansion are:

Steel— $12 \times 10^{-6}/^\circ\text{C}$, Duralumin— $23 \times 10^{-6}/^\circ\text{C}$, Nichrome V— $11.9 \times 10^{-6}/^\circ\text{C}$.

[Ans. 2.5×10^{-3} , 0.025×10^{-3} , 7.15×10^{-3} , 2.7×10^{-3}]

10. A Wheatstone bridge is shown in Fig. 29.6. If $R_1 - R_2 = R_3 = R_4$ at balance and if R_1 and R_2 are two strain gauges subjected to equal strains but of opposite nature such that $\Delta R_1 = -\Delta R_2$ while $\Delta R_3 = \Delta R_4 = 0$, prove the voltage e_0 of the bridge is linear function ΔR_1 , no matter how large ΔR_1 gets.

11. A gauge has a resistance of 120Ω and a gauge factor of 2.1. It is shunted by a resistance of $100 \text{ k}\Omega$. What equivalent strain will be indicated when the gauge is shunted. [Ans. 570 microstrain]

12. A gauge of resistance 120Ω and a gauge factor of 2.1 is to provide an equivalent strain of 100 micro-strain. Find the value of shunt resistance. [Ans. 571, 880 Ω]

13. For an electrical strain gauge of resistance 100Ω and a gauge factor of 2, determine the value of shunt resistance to calibrate for a strain of (a) 0.001, (b) 0.0005, (c) 0.0001. [Ans. (a) 499900Ω , (b) 99900Ω , (c) 49900Ω]

14. A point on a vibrating body has a simple harmonic motion. Determine at frequency of 10 Hz and 10 kHz, (a) the amplitude of acceleration if its displacement amplitude is 1 mm, (b) its displacement amplitude if the acceleration amplitude is 1 g. [Ans. (a) 0.4 g , $400,000 \text{ g}$ (b) 2.5 m , $0.005 \mu\text{m}$]

15. An inductive pickup operating from a 60 tooth wheel is used with a digital frequency meter to determine the speed of rotation of a shaft on which the wheel is mounted. The gating period is set to $10^6 \mu\text{s}$ and a reading of

0.024 is obtained on the 4 digit display. What shaft speed does this represent in r.p.s. ? If the available gating periods are $10^2, 10^3, 10^4, 10^5, 10^6$ and $10^7 \mu s$ respectively, what would be the optimum setting of gating period for making this measurement ? [Ans. 40 r.p.s, $10^{-7} \mu s$]

16. In order to measure a speed higher than flashing rate of stroboscope the flashing rate was gradually reduced from the highest noting all the speeds at which single image is observed of a mark on the rotating object. These speeds are 20,000, 15,000, 12,000 and 10,000, rpm. Calculate the actual speed. [Ans. 60,000 rpm]

17. A stroboscope projects 6000 flashes per minute on a disc with 10 patterns mounted on the shaft of a machine (a) Find the speed of machine if the disc appears stationary and has a single image of points.

(b) What would be the two possible shaft speeds if the 10 points appear to be revolving once in 12 s ? [Ans. (a) 600 rpm (b) 605,595 rpm]

18. For the purposes of checking the dial calibration of a stroboscope the dial was set to 1000 rpm and flashes were allowed to fall on the shaft of a synchronous motor running perfectly at 1000 rpm. The single image took 15 s to complete a rotation and it was seen moving in the direction of rotation of the shaft (a) what should have been the dial reading instead ? (b) If the image had been moving opposite to shaft rotation, what should have been the dial reading? [Ans. (a) 996 rpm. (b) 1004 rpm]

19. Calculate the frequency ratio for which the error in acceleration is 1% if the damping factor is 0.7. [Ans. 0.306]

20. A seismic accelerometer sensing displacement has an undamped frequency of 20 Hz and a damping ratio of 0.7. Calculate (a) its damped frequency (b) the amplitude ratio and phase angle between the motion of the seismic mass and the applied vibration if the latter is a sinusoidal displacement at a frequency of (i) 30 Hz and (ii) 1 kHz. [Ans (a) 14 Hz, (b) 0.92, $120^\circ 46' 10''$, $178^\circ 24'$]

21. A piezoelectric accelerometer has a transfer function of 61 mV/g and a natural frequency of 4500 Hz. In a vibration test at 110 Hz, a reading of 3.6 V peak is obtained. Find the vibration peak displacement. [Ans. 1.21 mm]

22. An accelerometer shown in Fig. 29.56 consists of a mass 50 g attached to a spring cantilever. The spring is made from mild steel having an elastic modulus of 206 GN/m² and is of uniform rectangular cross-section. The output is obtained from a strain gauge bridge and amplifier. Two active gauges are used, one is each side of cantilever. The unstrained resistance of gauges is 200 Ω each and the resistance of other two arms are 10 k Ω each. Determine the horizontal acceleration if the amplifier output is 1 V. The output of amplifier is given by $e_o = 30 (R_2/R_1) G f e$. The gauge factor is 2.

The dimensions of the frame are : $l=90$ mm, $b=10$ mm, $d=0.5$ mm. [Ans. 0.64]

23. An accelerometer for shock is designed as shown in Fig. 29.103. Find the relation between strain gauge resistance change and shock. The mass is 0.02 kg. The force rod has a modulus of elasticity of 0.1 GN/m. The cross-sectional area is $0.2 \times 10^{-6} \text{ m}^2$. The strain gauge has an unstrained resistance of 120 Ω and a gauge factor of 2.03. [Ans. $2.39 \times 10^{-3} \Omega/g$]

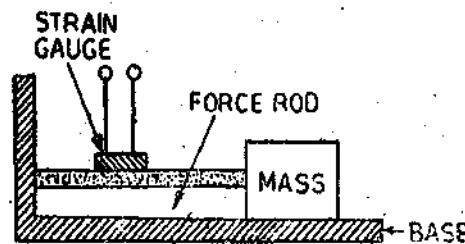

Fig. 29.103

24. A resistance wire thermometer with a fundamental interval of 10 Ω is connected by two copper wires into a Wheatstone bridge, with no compensating leads. Each of the connecting wires has a resistance of 4 Ω at the ambient temperature at the time of calibration. If the range of the bridge indicator is 0–250 $^\circ\text{C}$, find the approximate error, as a percentage of f.s.d. which will be caused by a change of 10 $^\circ\text{C}$ in the temperature of leads. The resistance temperature co-efficient of copper is 0.0044/ $^\circ\text{C}$. [Ans. 1.4%]

25. The hot junction of a chromel alumel thermocouple is connected to a potentiometer terminals is at 24 $^\circ\text{C}$. The potentiometer whose terminals are at 24 $^\circ\text{C}$ reads 25.76 mV. What is the temperature of the thermocouple junction ? The calibration chart of the thermocouple is :

Temperature $^\circ\text{C}$	20	24	28	480	488	493
Voltage, mV	0.8	0.95	1.12	26.25	26.72	26.04

[Ans. 488 $^\circ\text{C}$]

26. A thermopile arrangement of the copper constantan thermocouple consists of three junction pairs and has the reference junction at 200°C. If the output voltage is 3.3 mV, determine the temperature of the detecting junction. The calibration chart for a thermocouple junction is :

Temperature °C	100	200	250
Voltage, mV	4.22	9.23	11.95

[Ans. 171.95°C]

27. A PMMC instrument has a resistance of 5 Ω and is calibrated to read correctly when the resistance of the external circuit is 1 Ω. Calculate the percentage error if the resistance of the circuit is changed to 4 Ω. What would have been the error if the PMMC instrument had a resistance of 500 Ω ? [Ans. 2.2%, 0.397%]

28. The emf of an iron-constantan thermocouple is to be measured by the potentiometer shown in Fig. 29.69. A potential difference of 1.0186 V is applied over points AB and is standardized using a Weston cell. The current through the resistors is to be 2 mA, and the range of temperature measurement is to be from 250 °C to 850 °C. Calculate the value, of resistance R_1 , R_2 and R_3 for an ambient temperature of 20 °C. The emf of the iron constantan couple with reference junction at 0 °C is :

emf 20 °C = 1.019 mV, emf at 250 °C = 13.553 mV, emf at 850 °C = 48.716 mV.

[Ans. $R_1 = 6.27 \Omega$, $R_2 = 485.5 \Omega$, $R_3 = 17.58 \Omega$]

29. In a radiation pyrometer, the energy emitted from a piece of metal is measured. A surface emissivity of 0.82 is assumed and the temperature is determined as 1000 K. However, it is later found that the emissivity is 0.76. Find the error in the temperature determination. [Ans. 19 °C]

30. The liquid level in a tank is to be measured using the upthrust from a float shown in Fig. 29.104. The upthrust deflects a cantilever on which a float is mounted. The deflection is measured by a voltage potential divider and a voltmeter. The sensitivity of the transducer is 10 V/m. If the maximum height h of the water in the tank is 2 m and cross-sectional area of the float is 0.2 m², calculate the required stiffness of the cantilever in N/mm if the meter range is 50 V.

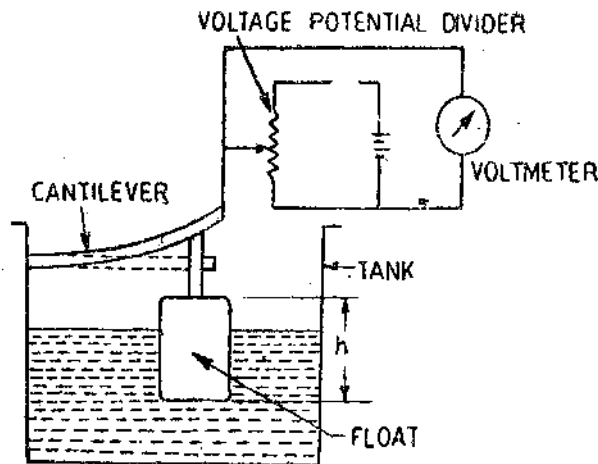

Fig. 29.104

Data Acquisition Systems

30.1. Instrumentation Systems. An instrumentation system is an aggregation or assembly of devices united by some form of regular interaction or an interdependence. It is a group of diverse units or devices so combined by nature or by an art to form an integral whole, and to function, operate or move in unison, and often in obedience to some form of control.

The demands for more and faster information from physical systems and devices used for space and nuclear research and development, and for industrial automation, have produced many new and effective instrumentation systems for data acquisition and reduction.

Data-acquisition systems are used to measure and record analog signals in basically two different ways :

(i) Signals which originate from direct measurement of electrical quantities. These signals may be d.c. or a.c. voltages, frequency, or resistance, etc.

(ii) Signals which originate from use of transducers.

30.2. Types of Instrumentation Systems. The instrumentation systems can be classified into two distinct categories :

1. **Analog Systems.** These systems deal with information in analog form. An analog signal may be defined as continuous function, such as a plot of voltage versus time or displacement versus force.

2. **Digital Systems.** A digital quantity may consist of a number of discrete or discontinuous pulses whose time relationship contains information about the magnitude and the nature of the quantity under measurement.

30.3. Components of an Analog Data-Acquisition System. An analog data-acquisition system typically consists of some or all of the following elements :

1. **Transducers.** Transducers have been described in details in Chapter 25. It is desirable that an emf, obtained from the transducer proportional to the quantity being measured, is used as an input to the data-acquisition system. Therefore, transducers such as the thermocouples, strain gauge bridges, piezo-electric devices and photosensitive devices are used.

As an exception to this usual function of transducers, some sensors produce a frequency which can be counted with an electronic counter to obtain the integral of the measured quantity or it can modulate a telemetry transmitter, and can be reduced to a voltage with the help of a discriminator.

2. **Signal Conditioning Equipment.** Signal conditioning equipment includes any equipment that assists in transforming the output of transducer to the desired magnitude or form required by the next stage of the data acquisition system. It also produces the required conditions in the transducers so that they work properly.

Signal conditioners may include devices for amplifying, refining, or selecting certain positions of these signals.

Examples of signal conditioning equipment include known constant voltage sources for strain gauge bridges, zero bridge balance devices for strain gauge circuits, temperature-control devices for thermocouple junctions, voltage amplifiers and servo-systems.

3 Calibrating Equipment. Before each test there is a precalibration, and often after each test there is a postcalibration. This usually consists of a milli volt calibration of all input circuits and shunt calibration of all bridge-type transducer circuits.

4 Integrating Equipment. It is often desirable to know the integral or summation of a quantity. There are several ways of determining the time integral of a quantity. An analog integrating circuit can be used for a qualitative test. It has the possible danger of becoming overloaded and also its accuracy is low. Therefore, digital techniques are normally used for integration purposes.

Another method of effective summation, utilizes the emf from the conditioning equipment to be applied to a saturable core reactor in the resonant circuit of an oscillator. The change in reactance is proportional to the applied emf and produces a change in the frequency. This frequency is beat with a frequency equal to frequency of the oscillator when the input is zero. The beat frequency, which is directly proportional to the input voltage of the oscillator, is amplified and counted with a counter.

5. Visual Display Devices. Visual display devices are required for continuous monitoring of the input signals. These devices include panel mounted meters, numerical displays, single or multichannel CROs and storage type CROs, etc.

6. Analog Recorders. The methods of recording data in analog form have been discussed in details in Chapter 28. Analog recorders include strip chart recorders, Duddell's oscillograph, magnetic tape recorders and cathode ray oscilloscopes with photographic equipment.

7 Analog Computers. The function of a data acquisition system is not only to record data acquired by the transducers and the sensors but also to reduce this data to the desired form. An analog computer may be used as a data reduction device. The output voltage of an analog computer can either be recorded in analog form or be converted to a digital form for recording and further computations.

It should be noted that analog computations are usually less accurate than digital computations, yet it is generally more economical to compute data that are acceptable by analog methods using analog computers.

8. High Speed Cameras and TV Equipment. In many industrial processes, engine testing, and aerodynamic testing it is not possible for the test operator to have a view of the equipment being tested. Therefore, closed circuit TV is used to enable the operator to make visual observations of the test. Also high speed cameras are employed to obtain a complete visual record of the process for further analysis.

30.4 Components of a Digital Data Acquisition System. A digital data acquisition system may include some or all of the components shown in Fig. 30.1. The essential functional operations of a digital data acquisition system are :

- (a) handling of analog signals,
- (b) making the measurement,
- (c) converting the data to digital

form and handling it, and

- (d) internal programming and control.

The various components and their functions are described below :

1. Transducer. They convert a physical quantity to an electrical signal which is acceptable by the acquisition system.

2. Signal Conditioning Equipment. Signal conditioning equipment has been described earlier while dealing with analog data acquisition systems.

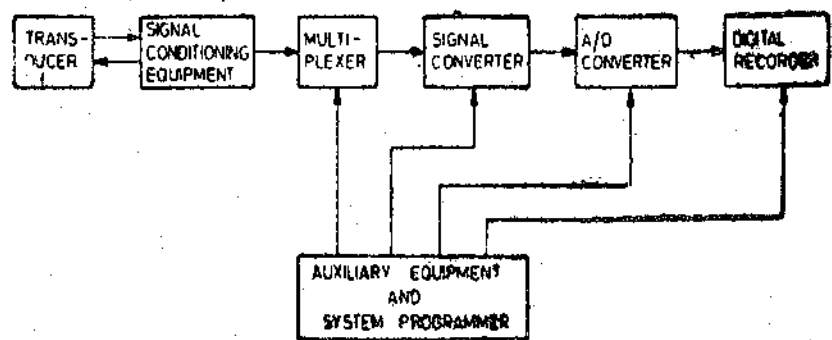

Fig. 30.1. Components of a digital data acquisition system.

3. **Multiplexer.** Multiplexing is the process of sharing a single channel with more than one input. Thus a multiplexer accepts multiple analog inputs and connects them sequentially to one measuring instrument. Another name for a multiplexer is "scanner".

4. **Signal Converter.** A signal converter translates the analog signal to a form acceptable by the analog to digital (A/D) converter. An example of the signal converter is an amplifier for amplifying the low-level signal voltages produced by transducers.

5. **Analog to Digital Converter (A/D Converter).** An A/D converter converts the analog voltage to its equivalent digital form. The output of the A/D converter may be fed to digital display devices for visual display or may be fed to digital recorders for recording. It may be fed to a digital computer for data reduction and further processing.

6. **Auxiliary Equipment.** This contains devices for system programming functions and digital data processing. Some of the typical functions done by auxiliary equipment are linearization and limit comparison of signals. These functions may be performed by individual devices or by a digital computer.

7. **Digital Recorders.** Records of information in digital form may be had on punched cards, perforated paper tapes, type written pages or magnetic tape, or a combination of these systems.

8. **Digital Printers.** After all the tests have been completed and the data generated, it becomes necessary to record the numbers and in some cases reduce the data to a more meaningful form. A digital printer can be specified to interface with an electronic instrumentation system in order to perform this work, and thus provide a high quality hard copy for records and minimizing the labour of the operating staff.

30'5. **Uses of Data Acquisition Systems.** Data acquisition systems are being used in ever-increasing, large and wide fields in a variety of industrial and scientific areas, including the aerospace, biomedical and telemetry industries. The type of data acquisition system to be used depends upon the application and the intended use of recorded input data.

Analog data acquisition systems are used when wide frequency width is required or when lower accuracies can be tolerated.

Digital data acquisition systems are used when the physical quantity being monitored has a narrow bandwidth (*i.e.*, when the quantity varies slowly). Digital systems are also used when high accuracy and low per channel cost is required.

Digital data acquisition systems are in general, more complex than analog systems, both in terms of instrumentation involved and the volume and complexity of the data they can handle.

30'6. **Use of Recorders in Digital Systems.** Data originating from digital sources may be plotted and displayed on an X-Y recorder. The sources of data include the following; (i) Keyboard, (ii) paper tape, (iii) punched cards, (iv) magnetic tapes, (v) teletype receiving terminals and (vi) computer readout.

Recorders may be coupled to digital system in two broad ways :

1. The recorder may be analog type, responding to voltage levels on each axis. Voltages for actuations of X and Y motions are derived from the output of a D/A converter, the input to these converters being furnished by the digital system involved.

2. The recorder is designed solely for digital systems and is fitted with step-by-step driver systems. The data enter the recorders at a bit rate suitable for the stepping speed of the digital recording system.

1. **Systems Using Analog Recorders.** Fig. 30'2 shows an outline of a circuit used to produce analog recorder signals from digital inputs. The controls shown are closed by keyboard keys. But in the case of tape or card reader, the controls are closed by either mechanical or solid state relays.

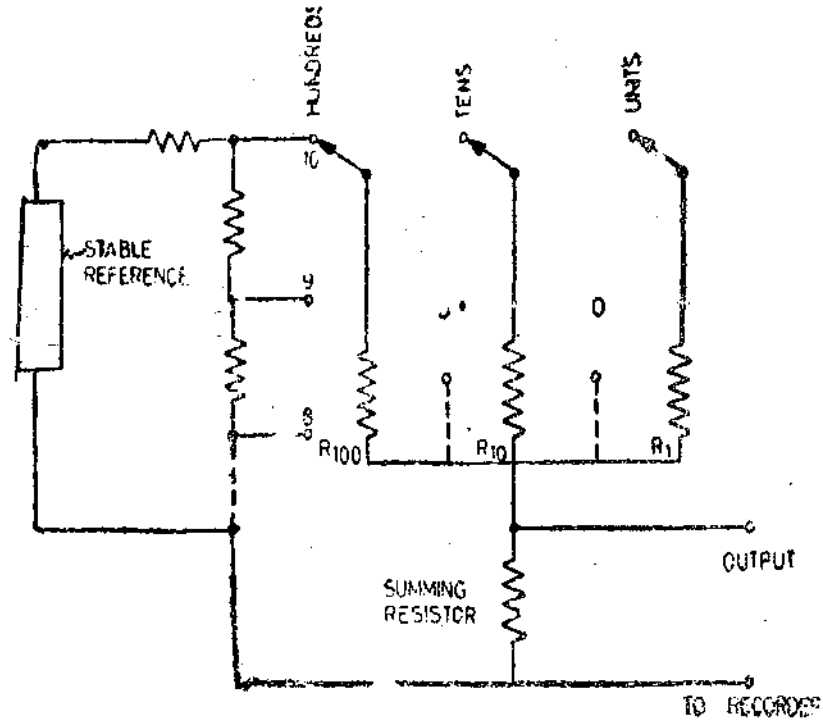

Fig. 30'2. Keyboard circuit diagram.

Fig. 30'3 shows in block form, the main elements of digital systems feeding an X-Y recorder. In each case the digital information must be conditioned to put it into analog voltage form.

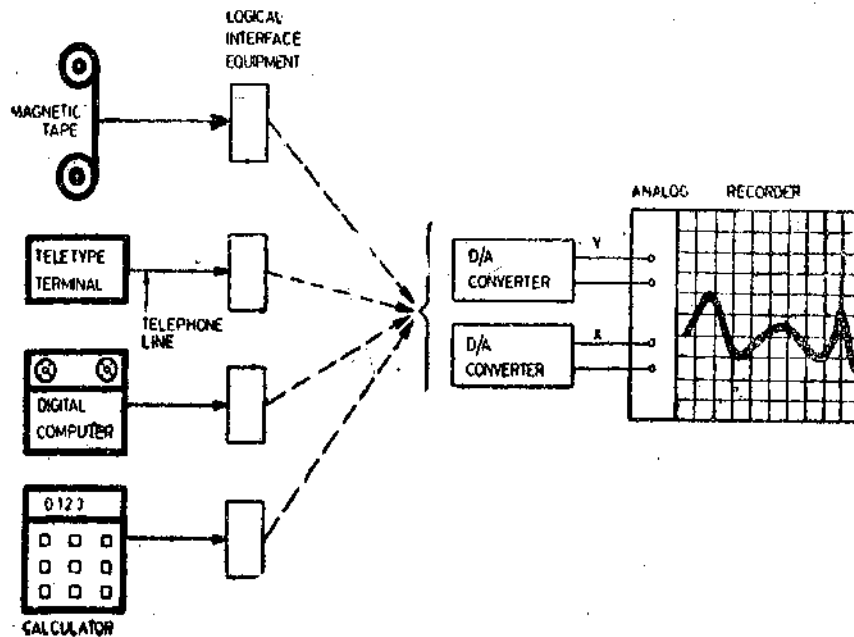

Fig. 30'3. Digital recording using analog recorder.

2. Systems Using Digital Recorders Fig. 30'4 shows the general set up of systems employing digital recorders. The computer is programmed to produce information broken down into X and Y-coordinates form and is operated at a rate acceptable to the recorder.

The recorder axes are driven by powerful and positive stepping motors giving an incremental movement to the recording system for each small step of data entered.

Successful application of these digital systems requires a thorough understanding of computer technology and programming.

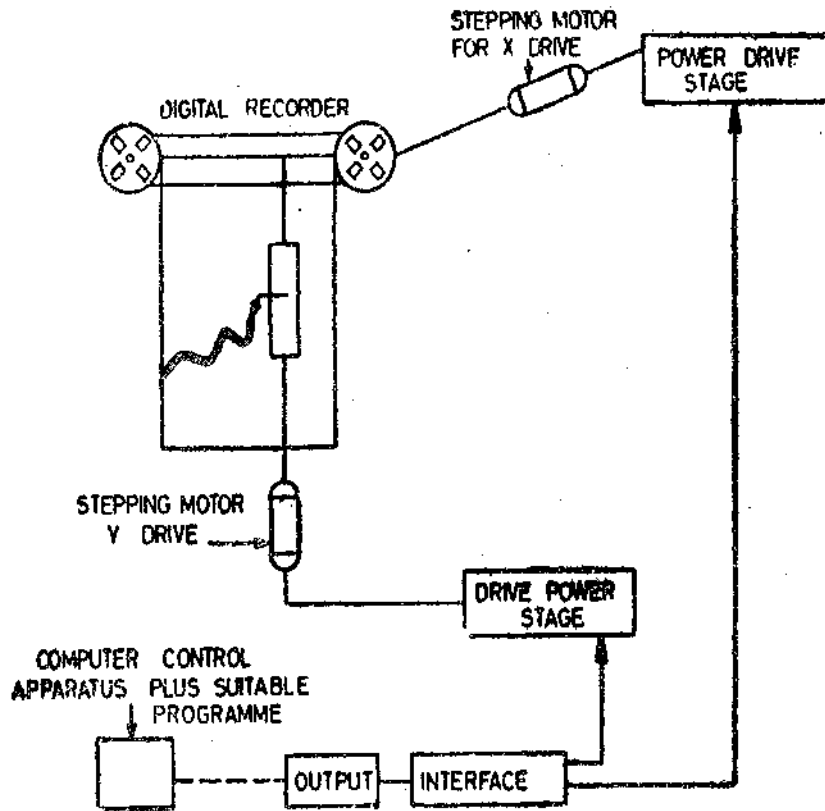

Fig. 30'4. Digital recording using digital recorder.

30.7. Digital Recording Systems. The most important feature of the digital systems is their ability to drive a printer or a paper punch. This enables the data recording system to be built around a digital instrument. A schematic diagram for accomplishing this job is shown in Fig. 30'5. A number of analog signals are multiplexed and fed to a digital converter, which is a digital voltmeter (DVM). The output of the DVM is fed to a printer or paper punch through a drive unit.

A digital clock sends a command pulse to initiate the scanning (multiplexing) of the analog inputs from transducers at some preselected time intervals (which may be 1 second, 1 minute or 1 hour). The output device is supplied with a signal from a clock simultaneously so that the time at

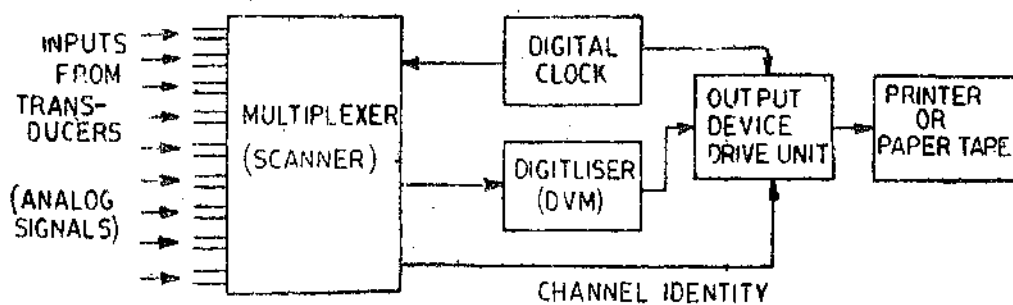

Fig. 30'5. Block diagram of a digital data recording system.

the start of multiplexing is recorded. The magnitude of the signal of each channel is identified in the record with recording the channel number through a channel identification adjacent to the magnitude of the signal.

The arrangement shown in Fig. 30'6 shows the important components of a data logger using a digital voltmeter (DVM). The data logger will assume greater importance if the different measurands like temperature, pressure, etc. are displayed in terms of their proper units instead of mere voltages in order to have proper interpretation of the data acquired from different sources. This requires pressure be displayed in terms of kN/m^2 and temperature be displayed in $^{\circ}\text{C}$ and so on. This desirable condition may be obtained by making some additions to the basic data logging system. For example, the compensation for ambient temperature changes may be made from the output

of thermocouples (used for monitoring temperature) and the input to the digitiser modified so that the output may be directly printed as temperature in °C. Similarly, the outputs from other transducers should be converted so that the data logger output is displayed in terms of units which are appropriate to the measurand of each channel. The arrangement of a modified data logger which is a comprehensive unit is shown in Fig. 30'6 so as to incorporate the requirements listed above.

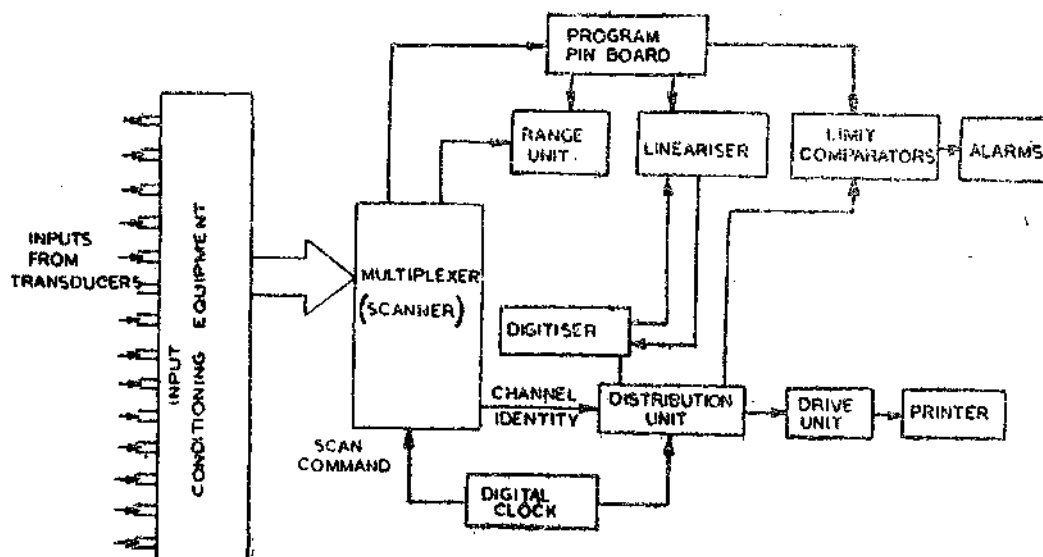

Fig. 30'6. Complete data logging system.

The functions of various parts of a complete data logging system are explained below :

30'71. Input Conditioning Equipment. The output of a transducer which is an input to the data logging system may either be an a.c. or a d.c. signal. If the input signal is a.c. a rectifying circuit must be inserted between the transducer and the data logger. This is because the input to a data logger which uses a DVM as a digitiser should normally be in the range of 0–50 mV d.c. However, the lower and upper limits at which the multiplexer works are 10 μ V and 100 V respectively. Therefore, voltages lower than 10 μ V are amplified while voltages higher than 100 V are attenuated. In case the signals are in the form of current, they must be converted to voltage drops (by passing the current through a known standard resistance) while pulse or variable frequency signals are converted to voltage signals by appropriate circuits.

30'72. Digitiser. The digitiser used in the data logging system is a digital voltmeter (DVM). The digital voltmeters have been discussed in chapter 28. These DVMs use counters which use a complete counting circuit for each decade of display. Here a digital voltmeter using a Recirculating Remainder System is described. In this system only one counting circuit is used and the output from this circuit is routed to each display in turn. This system reduces the number of components required for the instrument. The sequence of operation of this instrument is as follows :

(i) The unknown voltage is sampled and the most significant digit (MSD) of the unknown voltage is determined, (ii) The difference between the first digit's worth and the unknown is stored in a capacitor, (iii) The remainder is amplified by a factor of 10, (iv) The most significant digit (MSD) is then determined and the remainder is stored.

The steps (iii) and (iv) are cycled until the magnitude of the unknown voltage is displayed with the full available resolution.

Fig. 30'7 shows the schematic diagram of a recirculating remainder digital voltmeter. This voltmeter is battery operated and has a stroked display which reduces power consumption. Same capacitors are used for storing all the digits and therefore each digit is determined with the same precision. The sampling time is about 40 ms and reading rate is 40 per second.

The main features of this digital voltmeter are :

- (i) It has a high input impedance,
- (ii) It is an instrument with a high sampling rate,

- (iii) It has a much higher accuracy than analog instruments,
- (iv) It has a numerical display that gives a greater resolution and higher reading speed, and
- (v) It can be provided with an output facility for operating output devices like punched tape, magnetic tape or printer.

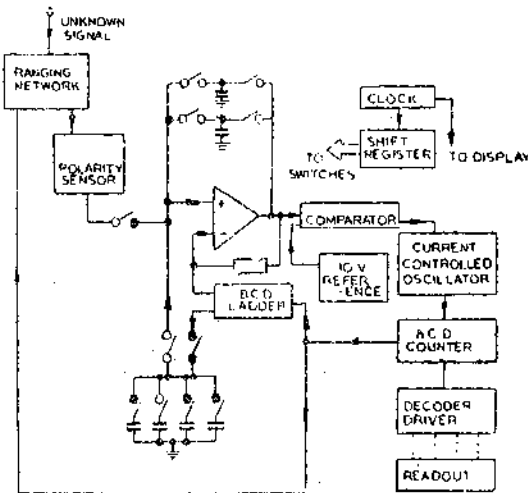

Fig. 30'7. Recirculating remainder digital voltmeter (DVM).

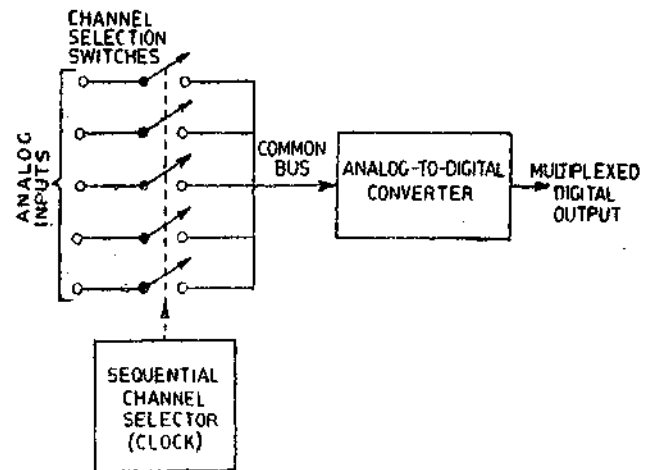

Fig. 30'8. Multiplexed A/D conversion system.

30'7.3. Multiplexer. The multiplexer of a data logger is a time controlled switch which selects and connects the inputs in a predetermined order and for a preselected period.

In an analog-to-digital conversion, it is convenient to multiplex the analog inputs rather than the digital outputs. One system of analog-to-digital multiplexing is shown in Fig. 30'8. The switches are solid state or relays, and are used to connect the analog inputs to a **Common Bus**. The solid state switches are characterised by a very high speed capability together with high cost which restricts their use to applications where speed is the overriding consideration. The electro-mechanical switches (relays) have superior switching characteristics, and are capable of switching speeds up to 100 channels per second. The switching of both types is normally time controlled by the digital clock. The common bus is connected to a single analog to digital converter which is used for all the channels. The analog inputs are switched sequentially to the bus by channel selector control circuitry. In case, simultaneous time samples are required, a sample and hold (S/H) circuit may be used before each multiplexer switch. In this manner, all the channels are sampled simultaneously and then switched to the A/D converter sequentially.

30'7.4. Program Pinboard. This is used for routing the signals to each channel via proper paths. Program pinboards are not used in all data loggers but are very useful in reducing the restrictions on the input signals thereby reducing the amount of scaling required to be performed on each channel at the input conditioning stage.

30'7.5. Lineariser. The inputs must be converted (scaled) to their appropriate form before being displayed. Many transducers produce an output voltage which is linearly proportional to the magnitude of the measurand and therefore for these, only a suitable voltage dividing network is needed to reduce the voltage to the compatible level of the data logger. However, the output characteristics, of some transducers like thermocouples, are non-linear. Therefore the output of these transducers is routed through an appropriately programmed circuit which does the linearisation of the signal (produces an output linearly proportional to the signal) and also converts the signal to the original form (i.e. converts the output of a thermocouple from voltage to temperature).

30'7.6. Digital Clock. The digital clock is synchronised to the power supply or to an internal crystal oscillator. This clock governs the timing throughout the system by applying triggering pulses to different parts of the system thereby initiating the sequences of events for recording each signal.

The digital clock is also used for supplying signals in order that the time of the day or the period elapsed may be recorded.

The principle of working of digital clocks is explained below :

The sequence of events is invariably controlled in digital systems. Therefore, it becomes essential to display and/or record time digital form. This function is performed by a digital clock. The time base for a digital clock is frequently derived from a power line frequency but for better accuracy a crystal oscillator or an atomic resonator can be used. Fig. 30.9 shows the block diagram of a digital clock which uses the power line frequency of 50 Hz for deriving its time base.

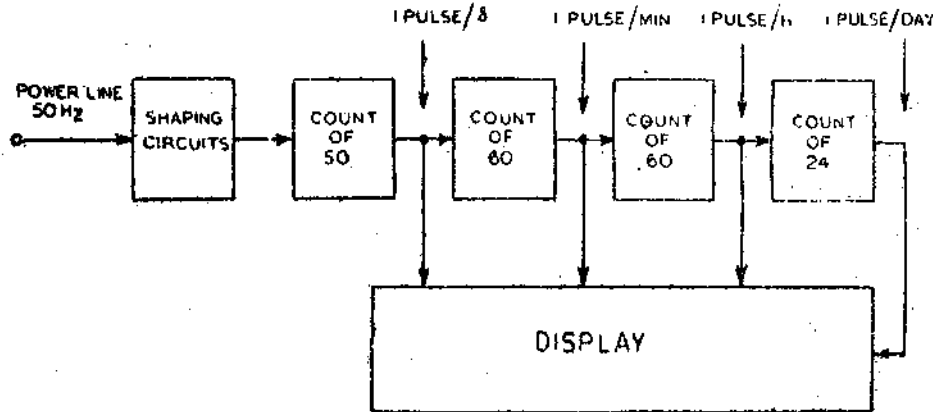

Fig. 30.9. Schematic diagram of a power line synchronized digital clock.

This clock is capable of displaying hours, minutes, and seconds on a 24 hour basis.

Instead of deriving 50 pulses per second from the power line, which may have additional spurious signals, the power line may be used to drive a synchronous motor which is coupled to a toothed rotor tachogenerator that produces 3000 or more pulses per second giving system command pulses and a resolution of 20 ms.

30.7.7. Limit Detectors. A series of limit detectors are provided in order to protect the different components of the automatic system against overloads. The limit detectors compare the magnitude of the signal of the selected signal with a preset safe voltage level. In case the level of the signal is in excess of the preset value, the protective devices are activated to switch off the system or alternatively alarm circuits are energised. The overloads may also be recorded by a special recorder say in red ink on a recording paper.

30.7.8. Output Devices A permanent record of the inputs may be obtained from output devices like paper tape punch, a strip or a line printer, an electric typewriter or a magnetic tape.

Punched Paper Tape. The punched paper tape record most frequently used is a 1 inch wide paper with 8 punched positions across the width. The patterns of holes or no holes represented by eight positions across the width of the tape encodes a particular value. An eight channel paper tape code is shown in Fig. 30.10.

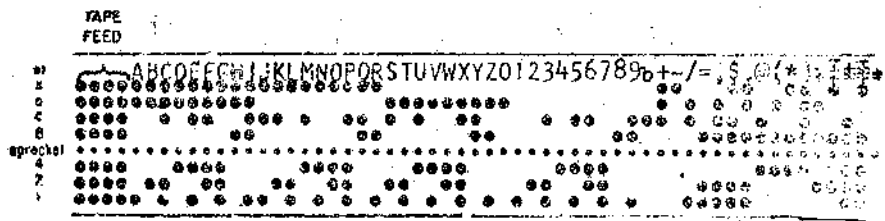

Fig. 30.10. An eight channel paper tape code.

Punched Cards. Data to be recorded can be encoded by a punched card shown in Fig. 30.11. Each card can store 80 alphanumeric values and the speed of punching can be as high as several

Appendix A

NUMBER SYSTEMS

A-1. Number Systems

In the history of mankind different number systems were developed. Today the decimal system is universally used. However, it is neither the only number system nor it is the simplest to use in many applications. In recent years, primarily due to the development of the digital computers and other digital instruments, the binary system has become increasingly popular.

A-2. Decimal Number System

The decimal number system uses 10 Arabic Indian symbols or digits. The digits are : 0, 1, 2, 3, 4, 5, 6, 7, 8 and 9 in order of ascending value. In any number system the number of different digits that may be employed is called radix. Thus, since the decimal system employs 10 digits, its radix is 10.

Now, in a decimal system the highest digit is 9. Numbers larger than 9 are constructed by assigning values or weights to the position of the symbol with respect to the decimal point.

Each position in a decimal number has a weight assigned to it which is ten times the value of the next position to the left of the decimal point. For example, in the decimal number 47, the positional value of digit 4 is ten times the positional value of digit 7. Every positional weight is a multiple of ten and can be expressed as 10 raised to some power. Starting at the decimal point the positional weight of the ones position is $10^0=1$. The next position to the left is the tens' position which carries a weight of $10^1=10$. The next position to the left, the hundreds' position, carries a positional weight of $10^2=100$. This progression of increasing exponents can be carried as far as left to the decimal point as desired. As mentioned earlier each digit has a weight or digit value. Standing by itself, the digit 4 has a value of four units. However, when the digit is associated with other digits to form a multidigit number, it has a positional weight in addition to its digit value. The positional weight of the digit at the extreme right of the number is unity or one. This is called the Least Significant Digit or simple LSD.

The digit occupying the extreme left position has the greatest positional weight and is called Most Significant Digit (MSD).

We have seen that in a decimal system, the positional weights increase tenfold each time we move by one position to the left. Thus these positional weights may be represented in ascending order of powers of 10.

We have considered whole number integers till now. When we write a decimal fraction (i.e., a value less than unity), we place a dot, called radix point (which is called a decimal point in the decimal system) between the integers and the fraction to separate two sets of digits. Then each digit of the fraction has a proportional weight that is one tenth the weight of the position to its left. Since positional weights, change one-tenth time every time we move from left to right by one position and thus a similar progression can be carried to the right of the decimal point but here the exponents are negative. The first position to the right of decimal point has a weight of $10^{-1}(=1/10)$, the second has a weight of $10^{-2}(=1/100)$ and so on.

A decimal system can be represented as in Fig. A'1. The digit placed in each box indicates how many multiples of the indicated power of ten are part of the total quantity represented by that number.

Consider the decimal number of 5642.37. We can write the value of each digit as represented by its relative position to the decimal point.



Fig. A-1. Diagrammatic representation of a Decimal System.

$$\begin{aligned}
 5642.37 &= 5 \times 10^3 + 6 \times 10^2 + 4 \times 10^1 + 2 \times 10^0 + 3 \times 10^{-1} + 7 \times 10^{-2} \\
 &= 5000 + 600 + 40 + 2 + 0.3 + 0.07 \\
 &= 5642.37.
 \end{aligned}$$

A-3. A General Number System

Any number can be used as a radix of a number system as long as the positional weights are adjusted accordingly. A positive digital number may be expressed as :

$$N = d_n d_{n-1} \dots d_3 d_2 d_1 d_0 d_{-1} d_{-2} \dots \dots \dots \quad \dots(A'1)$$

where $d_n, d_{n-1}, \dots, d_3, d_2, d_1, d_0, d_{-1}, d_{-2}$ etc., are individual digit symbols.

$$\text{Magnitude } N = d_n R^n + d_{n-1} R^{n-1} + \dots + d_3 R^3 + d_2 R^2 + d_1 R^1 + d_0 R^0 + d_{-1} R^{-1} + d_{-2} R^{-2} + \dots \dots \dots \quad \dots(A'2)$$

where R =radix of the system. The radix of a number system refers to the number of basic symbols used.

Let us take an example from the decimal system. In a decimal system, there are 10 basic symbols 0, 1, 2, 3, 4, 5, 6, 7, 8, 9 and therefore, $R=10$. Consider a number 46753.28.

Now $N=46753.28$. We have $d_4=4, d_3=6, d_2=7, d_1=5, d_0=3, d_{-1}=2$ and $d_{-2}=8$.

Applying Eqn. A'2, we get magnitude of number as :

$$\begin{aligned}
 N &= d_4 R^4 + d_3 R^3 + d_2 R^2 + d_1 R^1 + d_0 R^0 + d_{-1} R^{-1} + d_{-2} R^{-2} \\
 &= 4 \times 10^4 + 6 \times 10^3 + 7 \times 10^2 + 5 \times 10^1 + 3 \times 10^0 + 2 \times 10^{-1} + 8 \times 10^{-2} \\
 &= 40,000 + 6,000 + 700 + 50 + 3 + 0.2 + 0.08 = 46753.28.
 \end{aligned}$$

This agrees with our earlier result.

The diagrammatic representation of a general number system with radix R is given in Fig. A-2.

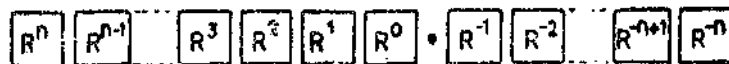

Fig. A-2. Skeleton of a general number system.

There are some other number systems in use. A binary system has a radix of 2 while an octal system has a radix of 8. The duodecimal system has a radix of 12 while hexadecimal system has a radix of 16. Except for binary system, the use of other systems is limited.

A-4. Binary Number System

A binary number system has a radix $R=2$ and uses only two symbols 0 and 1. These symbols represent an off-on system. Off state is represented by symbol 0 and On state by 1 and thus the binary

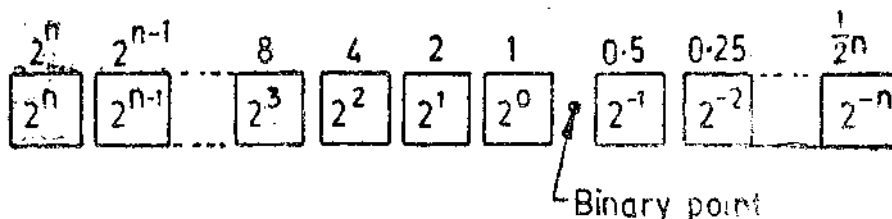

Fig. A-3. Skeleton of binary system.

system is very well suited to switching circuits. The numbers 0 and 1 are known as bits. In a binary system, the positional weights increase from right to left as in decimal system, only this time the increase is in ascending powers of 2. The skeleton of binary system is represented as in Fig. A-3.

Thus the position weight of the first digit on the right of binary point is $2^0=1$; the second position has a weight of $2^1=2$; the third has a weight of $2^2=4$ and so on. Similarly the positional weights of digits on the right of the binary point are:

First digit $-2^{-1}=1/2=0.5$, Second digit $-2^{-2}=1/2^2=0.025$

Third digit $=2^{-3}=1/2^3=0.0125$ nth digit $-2^{-n}=1/2^n$

Decimal number 1 $=1 \times 2^0=1$ in binary, Decimal number 2 $=1 \times 2^1+0 \times 2^0=10$ in binary

Decimal number 3 $=1 \times 2^1+1 \times 2^0=11$ in binary.

The conversion of decimal numbers to binary is given in Table A-1.

TABLE A-1

Conversion of Decimal Numbers to Binary Numbers

<i>Decimal</i>	0	1	2	3	4	5	6	7	8	9
<i>Binary</i>	0	1	10	11	100	101	110	111	1000	1001

Table A-2 is a partial table showing the positional weights of the digits of the binary system.

TABLE A-2

Positional Weights of Digits of a Binary System

		<i>Digit Positions</i>										
		2^6	2^5	2^4	2^3	2^2	2^1	2^0	2^{-1}	2^{-2}	2^{-3}	2^{-4}
<i>Positional Weights</i>	<i>Powers of two</i>											
	<i>Decimal value</i>	64	32	16	8	4	2	1	0.5	0.25	0.125	0.0625
<i>Digit values</i>		0	0	0	0	0	0	0	0	0	0	0
		1	1	1	1	1	1	1	1	1	1	1

It should be understood that the prefixes before the powers of 2 in a binary system have to be either of the two bits viz. 1 or 0.

For example we can write:

Decimal number 28 $=3 \times 2^3+1 \times 2^2+0 \times 2^1+0 \times 2^0=3100$

Now it involves an extra digit 3 which is not included in the binary system. Therefore we write decimal number 28 in binary system as:

Decimal number 28 $=1 \times 2^4+1 \times 2^3+1 \times 2^2+0 \times 2^1=1110$ (in binary).

It should also be understood that the binary number 1110 is read as one one one zero and not one thousand one hundred and ten.

A-5. Binary to Decimal Conversion

Binary quantities can be converted into their decimal equivalents. This can be electronically converted but we must examine the techniques behind them. This conversion is usually done by :

(i) Direct method, and (ii) Double dabble method.

The direct method is only described.

(i) Direct Method. This method employs Eqn. A-2. Let us illustrate that with an example.

Example A.1. Convert binary number 11001 into its decimal equivalent.

Solution. For binary number 11001, we have : $d_4=1$, $d_3=1$, $d_2=0$, $d_1=0$ and $d_0=1$.

$$\begin{aligned} \text{Magnitude of } N &= d_4R^4 + d_3R^3 + d_2R^2 + d_1R^1 + d_0R^0 \\ &= 1 \times 2^4 + 1 \times 2^3 + 0 \times 2^2 + 0 \times 2^1 + 1 \times 2^0 \\ &= 16 + 8 + 0 + 0 + 1 = 25. \end{aligned}$$

The conversion of binary mixed numbers and factors is illustrated by the following example.

Example A.2. Convert binary mixed number 100.110 into its decimal equivalent.

Solution. Binary number = 100.110

$$\therefore d_2=1, d_1=0, d_0=0, d_{-1}=0, d_{-2}=1, d_{-3}=0$$

$$\begin{aligned} \therefore \text{Magnitude of binary number} &= 1 \times 2^2 + 0 \times 2^1 + 0 \times 2^0 + 1 \times 2^{-1} + 1 \times 2^{-2} + 0 \times 2^{-3} \\ &= 4 + 0 + 0 + 0.5 + 0.25 + 0 = 4.75. \end{aligned}$$

A-6. Decimal to Binary Conversion

The binary to decimal conversion becomes a necessity at the output of terminals of a binary device such as a digital computer

1. **Direct Method.** In this method the largest power of 2 is subtracted from the decimal number. The next step is to again subtract the largest power of 2 from the remainder. This process is repeated successively till no remainder is left.

2. **Double Dabble System.** This system of converting decimal into binary system is reverse of that of converting a binary system into a decimal system. The various steps involved are :

- (i) Divide the decimal number by 2. Record the remainder.
- (ii) Divide the first quotient by 2. Record the remainder.
- (iii) Divide the next quotient by 2. Record the remainder.
- (iv) Repeat the process till the final quotient is 0.
- (v) The remainders starting with the last one make up the equivalent binary number.

Example A-3. Convert the decimal number 93 into its binary equivalent by double dabble method.

Solution :

Number	Quotient	Remainder
93 ÷ 2	46	1
46 ÷ 2	23	0
23 ÷ 2	11	1
11 ÷ 2	5	1
5 ÷ 2	2	1
2 ÷ 2	1	0
1 ÷ 2	0	1

∴ Reading the remainder column from bottom to top, we get :

Decimal 93 = Binary 1011101.

Conversion of Decimal Fractions to Binary. The method is best illustrated by the following example :

Example A-4. Convert decimal fraction 0.6372 into its binary equivalent.

Solution :

<i>Number</i>	=	<i>Product</i>	=	<i>Integer</i>
0.6372 × 2	=	1.2744	=	1
0.2744 × 2	=	0.5488	=	0
0.5488 × 2	=	1.0976	=	1
0.0976 × 2	=	0.1952	=	0
0.1952 × 2	=	0.3904	=	0
0.3904 × 2	=	0.7808	=	0
0.7808 × 2	=	1.5616	=	1
0.5616 × 2	=	1.1232	=	1

and so on

∴ Decimal 0.6372 = Binary 0.10100011+

A-7. Arithmetic Processes in a Binary System

The basis of arithmetic processes of addition, subtraction, multiplication, and division in the binary system are the same as those used in the decimal system, except that only two digit symbols i.e. 0 and 1 are used.

A-7.1. Binary Addition

There are four types of addition in a binary system.

(i) 0+0=0, (ii) 0+1=1, (iii) 1+0=1, (iv) 1+1=0 with a carry of 1.

Example A-5. Find the addition of the two binary quantities : 110011 and 1111.

Solution :

1111	carry						
<table border="0" style="border-collapse: collapse;"> <tr> <td style="border-right: 1px solid black; padding-right: 5px;">10011</td> <td style="padding-left: 5px;">first quantity.</td> </tr> <tr> <td style="border-right: 1px solid black; padding-right: 5px;">+ 1111</td> <td style="padding-left: 5px;">second quantity.</td> </tr> <tr> <td style="border-right: 1px solid black; padding-right: 5px;">1000010</td> <td style="padding-left: 5px;">Total</td> </tr> </table>	10011	first quantity.	+ 1111	second quantity.	1000010	Total	
10011	first quantity.						
+ 1111	second quantity.						
1000010	Total						

A-7.2. Binary Subtraction

The simple rules of binary subtraction are :

(i) 0-0=0, (ii) 1-1=0, (iii) 1-0=1, (iv) 0-1=1 with a borrow of 1.

Example A-6. Subtract 110 from 11010. Both are binary numbers.

Solution :

$$\begin{array}{r}
 11010 \\
 - 110 \\
 \hline
 10100 \\
 \hline
 \hline
 \hline
 \end{array}$$

A-7.3. Multiplication of Binary Numbers. The multiplication of binary numbers is a simple affair since both multiplicand and the multiplier contain only digits 0 and 1. The rules are :

(i) $0 \times 1 = 0$, (ii) $1 \times 0 = 0$, (iii) $1 \times 1 = 1$

However, when the partial products are added, rules for binary addition must be adhered to.

Example A-7. Multiply binary numbers 1101 and 11011. Check the answer by converting numbers into equivalent decimal numbers.

Solution :

$$\begin{array}{r}
 1101 \\
 \times 11011 \\
 \hline
 1101 \\
 1101 \\
 0000 \\
 1101 \\
 1101 \\
 \hline
 10101111 \\
 \hline
 \hline
 \end{array}$$

Now Binary number 1101

$$= 1 \times 2^3 + 1 \times 2^2 + 0 \times 2^1 + 1 \times 2^0 = 13 \text{ (decimal)}$$

and $11011 = 1 \times 2^4 + 1 \times 2^3 + 0 \times 2^2 + 1 \times 2^1 + 1 \times 2^0 = 27 \text{ (decimal)}$.

Product $13 \times 27 = 351 \text{ (decimal)}$.

$$\text{Binary number } 10101111 = 1 \times 2^9 + 0 \times 2^8 + 1 \times 2^7 + 0 \times 2^6 + 0 \times 2^5$$

$$+ 1 \times 2^4 + 1 \times 2^3 + 1 \times 2^2 + 1 \times 2^1 + 1 \times 2^0 = 351 \text{ (decimal)}$$

This confirms with the answer obtained above.

A-7.4. Division of Binary Numbers. The general rules of division in decimal system are applicable to binary system. In this context it may be emphasised that we must obey the rules of binary multiplication and binary subtraction.

Example A-8. Divide binary number 110 by binary number

Solution :

$$\begin{array}{r}
 10 \quad \text{quotient} \\
 11) 110 \quad \text{dividend} \\
 \underline{11} \\
 000 \\
 \underline{000} \\
 0 \quad \text{remainder} \\
 \hline
 \hline
 \end{array}$$

\therefore Quotient = 10 (binary),

and Remainder = 0 (binary),

$$\text{Now Binary } 110 = 1 \times 2^2 + 1 \times 2^1 + 1 \times 2^0 = 6,$$

and Binary $11 = 1 \times 2^1 + 1 \times 2^0 = 3$.

$$6 \div 3 = 2.$$

In binary system 10 means a value of 2.

Thus the answer confirms to the solution obtained above.

Example A-9. Find the quotient of 10011 divided by 101.

Solution

$$\begin{array}{r}
 \overline{) 10011} \quad \begin{array}{l} \text{quotient} \\ \text{dividend} \end{array} \\
 \underline{101} \\
 1001 \\
 \underline{101} \\
 100 \\
 \underline{100} \quad \text{remainder}
 \end{array}$$

The answer in binary is $11 \frac{100}{101}$

Now Binary $11=3$ (decimal),

Binary $100=4$ (decimal),

and

Binary $101=5$ (decimal).

The answer in decimal system is $3\frac{4}{5}$.

This confirms to the decimal system as verified below.

Binary $110011 = \text{decimal } 19$.

Binary $101 = \text{decimal } 5$.

$$\begin{array}{r}
 \overline{) 19} \\
 \underline{15} \\
 4
 \end{array}$$

\therefore The answer in decimal system is $3\frac{4}{5}$

A-8. Binary Coded Decimal Systems (BCD)

The decimal numbers have been used for centuries and their use would continue. But the digital systems require the use of binary numbers. The compromise between the two systems can be had by using binary coded decimals (BCD). These codes combine the features of both decimal and binary numbers where a decimal read-out of a binary is required, it is sometimes convenient to use a modified version of binary code in which the length of the code sequence is restricted to 10 digits before it is repeated. In fact binary coded decimal (BCD) notation is a special way of expressing decimal quantities in binary form. In BCD notation, each digit of the original decimal number is expressed directly as a four digit binary group. The number of binary groups is then equal to the number of digits in the original decimal number.

The main binary codes used are :

(i) 4 bit binary codes, (ii) Excess-3 code, (iii) Parity code, and (iv) Gray code.

A-9. The 8421 Code

The most commonly used BCD code is the so called 8-4-2-1 code. This is a four bit code which does not conform to Eqns. A-1 and A-2 but is a composite system using binary numbers from

0 to 1001 to represent decimal numbers from 0 to 9. The 8-4-2-1 code expresses each decimal digit by its four-bit binary equivalent. We cite here a few examples of equivalents between decimal and BCD (8421) systems.

<i>Decimal</i>	<i>BCD (8421)</i>			
4	0000	0000	0000	0100
19	0000	0000	0001	1001
100	0000	0001	0000	0000
5000	0101	0000	0000	0000

The first group of four digits on the right in the BCD numbers are the binary equivalent numbers of the first digit on the right in the decimal number. The other groups of 4 digits from right to left are binary equivalents of decimal digits of tens, hundreds, thousands respectively.

Table A-3 gives more information about the 8-4-2-1 code. It is seen that each decimal digit is changed to its equivalent four bit groups. It should be noted that 1001 is the largest four-bit group

TABLE A-3

Decimal Numbers and their Equivalents in BCD (8421)

<i>Decimal</i>	<i>BCD (8421)</i>			
0	0000	0000	0000	0000
1	0000	0000	0000	0001
2	0000	0000	0000	0010
3	0000	0000	0000	0011
4	0000	0000	0000	0100
5	0000	0000	0000	0101
6	0000	0000	0000	0110
7	0000	0000	0000	0111
8	0000	0000	0000	1000
9	0000	0000	0000	1001
10	0000	0000	0001	0000
11	0000	0000	0001	0001
12	0000	0000	0001	0010
13	0000	0000	0001	0011
14	0000	0000	0001	0100
15	0000	0000	0001	0101
98	0000	0000	1001	1000
99	0000	0000	1001	1001
100	0000	0001	0000	0000
101	0000	0001	0000	0001
109	0000	0001	0000	1001
579	0000	0101	0111	1001
4728	0100	0111	0010	1000

in the 8-4-2-1 code. Therefore, only 10 of the 16 possible four-bit groups are used. The 8-4-2-1 code does not use the numbers 1010, 1011, 1100, 1101, 1110 and 1111. An error will occur if any of these numbers are fed into a digital computing machine. These numbers, in fact, are forbidden for a 8-4-2-1 BCD.

The 8421 code is identical to binary upto the decimal number 9. Above 9, the 8-4-2-1 code differs from the binary number code. For example the binary number for 15 is 1111, but the 8421 number for 15 is 0001, 0101. Taking another example, the decimal number 24 is 11000 in binary but it becomes 0010, 0100 in the 8-4-2-1 code. Thus, above decimal number 9, every binary number differs from the corresponding 8-4-2-1 number.

The 8-4-2-1 code is identical to binary through to the decimal number 9. Because of this, it is called 8-4-2-1 code. The weights in the groups are 8, 4, 2, 1 reading from left to right.

However, above 9, the 8421 BCD code differs from the binary number code. For example, the binary number for 14 is 1110, but the same number as used in BCD (8421) is 0001, 0100.

The first group of four digits on the right in the BCD numbers are the binary equivalent numbers equivalent of the first digit on the right in the decimal number. The other groups of 4 digits from right to left are the binary equivalents of decimal digits of tens, hundreds and thousands respectively. This system is extensively used to keep the numbers in a form that can easily be read in the decimal system and easily interpreted by the observer and recorded in decimal form.

Example A-10. Express 6932 in the 8-4-2-1 code.

Solution. Each digit of the decimal number is expressed in the pure binary form as :

$$6 = 0 \times 2^3 + 1 \times 2^2 + 1 \times 2^1 + 0 \times 2^0 = 0110$$

$$9 = 1 \times 2^3 + 0 \times 2^2 + 0 \times 2^1 + 1 \times 2^0 = 1001$$

$$3 = 0 \times 2^3 + 0 \times 2^2 + 1 \times 2^1 + 1 \times 2^0 = 0011$$

$$2 = 0 \times 2^3 + 0 \times 2^2 + 1 \times 2^1 + 0 \times 2^0 = 0010.$$

The binary groups are moved together to form the BCD notation and

Decimal 6932 = 0110 1001 0011 0010.

A typical example of the 8-4-2-1 code is the perforated tape used with digital computers. Fig. A-4 illustrates how the binary bits are represented by punched holes on the tape. A punched hole indicates 1 and the absence of hole indicates binary 0. A total of four positions is available across the width of the tape to accommodate four digit code. The holes represented in Fig. A-4 represent a decimal number read from top to bottom. Many BCD codes have been developed. To cite a few examples we have Aiken 2-4-2-1 BCD and Johnson code. Biquinary codes are often used in computers.

Example A-11. Convert the following 8421 numbers into decimal system :

(i) 1000 0101 0110 0011

(ii) 0011 0101 0001 1001 0111

Solution. Divide the BCD (8421) numbers into groups of four and then decode them :

(i) 1000 0101 0110 0011

1000=8, 0101=5, 0110=6, 0011=3.

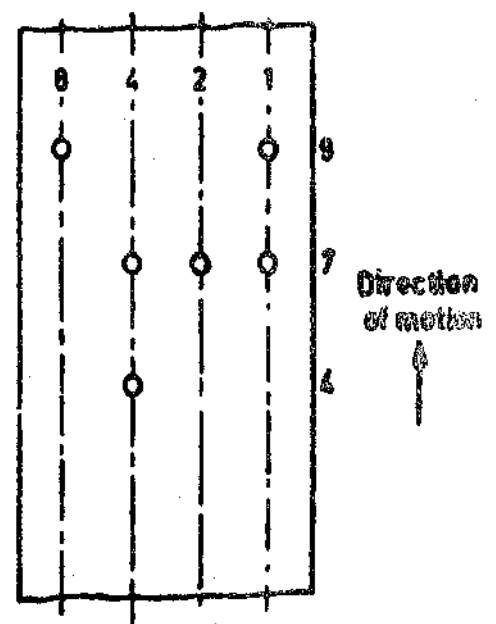

Fig. A-4. Binary coded tape.

Therefore BCD 1000 0101 0110 0011 = Decimal 8563.

(ii) $\begin{array}{cccccc} 0011 & 0101 & 0001 & 1001 & 0111 \\ \hline & & & & \end{array}$

0011 = 3, 0101 = 5, 0001 = 1, 1001 = 9, 0111 = 7.

∴ BCD (011 0101 0001 1001 0111) = Decimal 35197.

The main advantage of the 8-4-2-1 code is the ease of converting to and from decimal numbers. We need only remember the binary numbers 0 to 9 because we encode only one decimal digit at a time. A disadvantage, however, of the 8-4-2-1 code is that the rules for binary addition do not apply to the entire 8421 number, but only to the individual four bit groups.

Example A-12. Add decimal numbers 12 and 9 in binary and BCD (8-4-2-1) system. Comment upon the result.

Solution. Decimal 12 = Binary 1100

Decimal 9 = Binary 1001

Decimal-addition = 12 + 9 = 21

Binary addition :

$$\begin{array}{r} 1100 \\ 1001 \\ \hline 10101 \\ \hline \end{array}$$

In BCD (8-4-2-1)

Decimal 12 = $\begin{array}{cccc} 0000 & 0000 & 0001 & 0010 \\ \hline & & & \end{array}$

Decimal 9 = $\begin{array}{cccc} 0000 & 0000 & 0000 & 1001 \\ \hline & & & \end{array}$

BCD addition = $\begin{array}{cccc} 0000 & 0000 & 0001 & 1011 \\ \hline & & & \end{array}$

The result is 0001 1011. This is untenable as it is not possible to decode 1011 as it does not exist in the 8-4-2-1 code. The largest 8421 group is 1-0-0-1 (9). Therefore addition of numbers in 8-4-2-1 code is not so simple as for binary numbers.

A-10. Other BCD Codes

The 8-4-2-1 code is one of the many codes referred to as binary coded decimal systems (BCD). A large number of such codes can be evolved. Since four bit BCD codes use only 10 of 16 possible states, we can evolve (16!/6!) possible codes, which are approximately 30 billion. The 8-4-2-1 code is a mixed base code. It is a binary within each group of four bits, but at the same time it is decimal from group to group. Since the 8-4-2-1 BCD code is the most natural type of BCD code, it is frequently referred to as BCD without any reference to it. Thus, without any reference to the contrary, we refer the BCD code as a 8-4-2-1 code.

Many other four bit codes exist like Aiken 2-4-2-1 and Johnson code. Table A-4 shows some commonly used BCD codes.

TABLE A-4
Four Bit BCD Codes

<i>Decimal</i>	<i>4221</i>	<i>2421</i>	<i>Excess 3</i>	<i>5211</i>
0	0000	0000	0011	0000
1	0001	0001	0100	0001
2	0010	0010	0101	0011
3	0011	0011	0110	0101
4	1000	0100	0111	0111
5	1001	0101	1000	1000
6	1010	0110	1001	1001
7	1011	0111	1010	1011
8	1110	1110	1011	1101
9	1111	1111	1100	1111

A-11. Gray Code

This code is an unweighted code, *i.e.* the various bits in their different positions do not represent their positional weight. Therefore this code cannot be used for arithmetic operations. However, it is very useful for input-output devices, A/D converters, etc.

TABLE A-5
Gray Code Numbers and their Binary Equivalents

<i>Decimal</i>	<i>Gray Code</i>	<i>Binary</i>	<i>Decimal</i>	<i>Gray Code</i>	<i>Binary</i>
0	0000	0000	8	1100	1000
1	0001	0001	9	1101	1001
2	0011	0010	10	1111	1010
3	0010	0011	11	1110	1011
4	0110	0100	12	1010	1100
5	0111	0101	13	1011	1101
6	0101	0110	14	1001	1110
7	0100	0111	15	1000	1111

In Gray code, each Gray number differs from the preceding number by a single bit. Table A-5 shows the Gray code numbers along with their binary equivalents. Examining the table, we find that decimal number 5 is represented by 0111 and decimal number next to it, i.e. 6 is represented by 0101. Thus there is a change in only one bit, i.e. these numbers differ in only one digit position, the second digit from right is changed from 1 to 0. Similarly while going from decimal number 14 represented by 1001 in Gray code to decimal number 15 represented by 1000 in Gray code, we find that only one bit, i.e. the least significant bit LSB has been changed from 1 to 0.

Thus we can generalize that in Gray code, every number differs by only one bit from the preceding number.

A-11. Conversion from Binary to Gray Code

Many a time, we have to convert binary numbers into Gray numbers. The following rules are followed for the conversion :

(i) The first Gray digit is the same as the binary digit.

(ii) Each pair of adjacent digits is added to get the next Gray digit. While performing this operation the carry is ignored.

The following examples explain the conversion :

Example A-13. The decimal number 7 is represented by 0111 in binary system. Convert this into a Gray number.

Solution. The most significant bit (MSB) which is 0 in this case is retained as such. Therefore the 1st position from left to right is occupied by 0 in the Gray number.

Next add 0 and 1. The result is 1. Thus the second digit from right is 1. Then add 1 and 1 and we get 0 with a carry of one. The carry is neglected. Therefore, the third digit from right is 0. Again add 1 and 1, the result is 0 and a carry of one. The carry is to be neglected and hence the fourth digit from the right is 0. Thus the Gray number equivalent to binary 0111 is 0100.

Example A-14. The decimal number 12 is represented as 1100 in binary. Find its Gray equivalent.

Solution. The binary number is 1100. For conversion to Gray number the MSB which is 1 in this case is retained for the first position at the right.

For the second position from the right in Gray code the first and the second bit from the right are added together. In this case they are both 1. Thus $1+1=0$ with a carry of 1. Thus in Gray code the second position from right is 0.

For the third place from right in Gray code, second and third bits in binary are added. Thus we have $1+0=1$. For the fourth place the third and fourth bits are added to yield the Gray bit. In this case they are 0 and 0. Thus $0+0=0$.

Thus the Gray code equivalent of binary 1100 is 1010.

A-12. Gray Code to Binary Conversion

In order to convert from Gray code to binary, we use a similar method that is used for binary to Gray code conversion. The rules for this conversion are :

(i) The most significant bit (MSB) is kept as the same.

(ii) The other bits are obtained by a diagonal addition as explained in the examples below.

Example A-15. Convert the Gray code number 0100 to its binary equivalent.

Solution. The MSB Gray code in this case is 0. It is kept as the same, i.e.

Thus	0100	Gray
	↓	
	0	Binary

Now add diagonally to get the next binary digit.

Thus 0 is added to 1 to get 1 in Binary. We have now

0100	Gray
01	Binary

The digit 1 in second place in binary is added to 0 in the third place in the Gray code. The result is 1. Thus we have :

0100	Gray
011	Binary

The last operation is to add the third digit from right in binary to fourth digit in the Gray code. Thus $1+0=1$

∴ The binary equivalent is : 0111.

Example A-16. Convert the Gray code number 1010 into its binary equivalent.

Solution. The MSB in Gray code is 1 and therefore it is retained as such in binary.

1010	Gray
1	Binary

The second digit from right in Gray code 0 is added to first digit on the right in binary and the result is 1

1010	Gray
11	Binary

The third digit from right in Gray code 1 is added to second digit from right in binary which is 1. $1+1=0$ with a carry of one which is neglected

1010	Gray
110	Binary

Finally the fourth digit from right 0 in the Gray code is added to third digit from right in binary which is 0.

∴ $0+0=0$

Hence the Binary equivalent of Gray number 1010 is : 1100.

Appendix B

LOGIC GATES

B-1 Introduction

Most of the questions encountered in nature and more particularly in scientific work are two valued. For example the question may be whether a particular statement is true or false. It may be whether a particular action is right or wrong. Thus most of the time of thinking of human beings is involved in finding answers in two levels. These may be say yes or no, high or low, true or false, or good or bad. The decisions have been discrete, the two states being absolutely distinguishable. The binary, for example, is a two level logic. It clearly distinguishes between the two states viz : 1 and 0.

The operation of the switching circuits of a computer is more easily described in symbolic logic, which is expressed in a system known as Boolean algebra. Boole proved that binary or two valued logic is valid for letter symbols instead of words. The advantages of Boolean algebra are simplicity, speed and accuracy. This system uses two values, 1 and 0, similar to binary numbers. The 1 state is defined as the true state and the 0 state as the false state in logic systems: In circuit analysis state 1 may be a closed circuit, a positive electrical potential, or an energised relay circuit, while state 0 may be an open circuit, a negative electrical potential or an unenergised relay. Control circuits that automatically select one specific case out of several alternatives for each possible combinations of inputs are called logic circuits.

B-2. Gate. A gate is a logic circuit with one output and two or more inputs. The output signal is produced when there is a specified combination of input signals.

B-3. OR Gate

Fig. B-1 shows an OR gate built with mechanical switches *A* and *B*. The output is a lamp *Y*. We see that whenever either of switches is closed or when both the switches are closed the lamp circuit is closed and the lamp gets lit up resulting in an output.

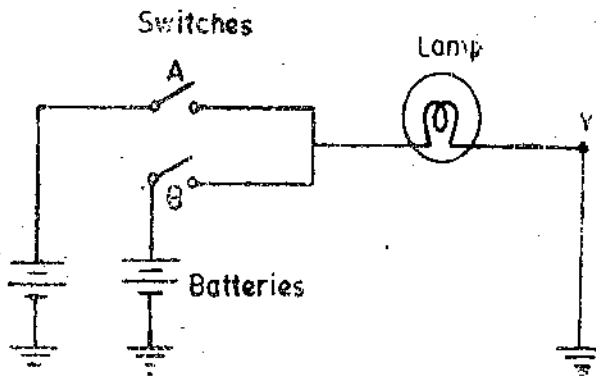

Fig. B-1. OR gate using mechanical switches and a lamp.



Fig. B-2. Symbol for two input OR gate.

When neither of the switches is on, the lamp does not glow and we don't get an output.

The mechanical switches can be replaced by diodes which act as electronic switches.

Thus in an OR gate an output occurs when any or all inputs are present. The symbol for a two input OR gate is shown in Fig. B-2.

B-4. Truth Table

A truth table is a table of combinations which shows all input-output combinations for a logic circuit.

Table B-1 is the Truth Table for a two input OR Gate.

TABLE B-1
Truth Table for OR Gate

A	B	$Y=A+B$
0	0	0
1	0	1
0	1	1
1	1	1

The equation $Y=A+B$ is read as Y equals A or B.

B-5. Logic Convention

In digital circuits we use diodes and transistors which act as switches. These diodes and transistors change from one voltage level to another. The 0 and 1 states do not necessarily mean 0 volt and 1 volt respectively. In fact 0 and 1 are represented by two different voltage levels called **low** and **high**. These voltage levels are distinguishable. For example a voltage of 2 volt may represent 0

and a voltage of 10 V may represent 1. It should be noted that the magnitudes of voltages are unimportant but their levels, whether LOW or HIGH is important and as explained earlier the two voltage levels should be different from each other and should be distinguishable.

Positive Logic. In positive logic convention, logic '1' is assigned to most positive (**high**) level of voltage and logic 0 is assigned to least positive (**low**) level of voltage.

Negative Logic. In negative logic convention, logic 1 is assigned to the most negative (**low**) level of voltage and logic 0 is assigned to least negative (**high**) level of voltage.

However, we will limit our discussions to **positive logic** only.

B-6. AND Gate

Fig. B-3 shows the circuit of an AND gate using two switches and a lamp which indicates the output.

It is clear that when any of the switches is in the off position (0 state) the lamp does not glow i.e., it is in state 0. The lamp glows (i.e., output=1) only when both the switches A and B are closed i.e., they are in 1 state.

The truth table for an AND gate is given in Table B-2.

TABLE B-2
Truth Table for AND Gate

A	B	$Y=A.B$
0	0	0
1	0	0
0	1	0
1	1	1

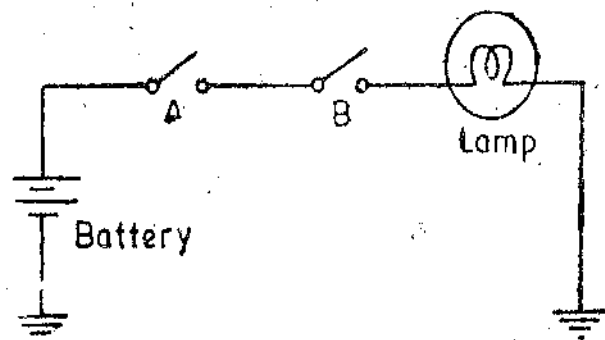

Fig. B-3. AND gate using mechanical switches.

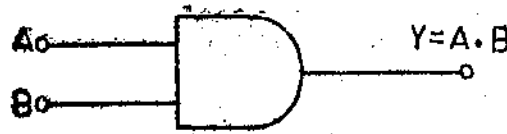

Fig. B-4. Symbolic representation of a two input AND gate.

The AND gate is so named because output Y equals 1 only if inputs A and B are 1.

The symbolic diagram for a two input AND gate is shown in Fig. B-4.

B-7. NOT Gate

The output of a NOT gate is a complement of the input *i.e.*, when input $A=0$, the output $Y=1$, thus the output is NOT 0 which is 1, while on the other hand when input $A=1$ the output is 0 which is NOT 1.

TABLE B-3
Truth Table for NOT Gate

A	$Y = \bar{A}$
0	1
1	0

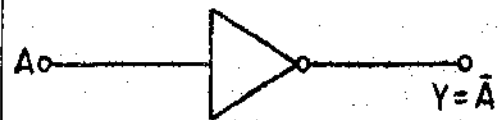

Fig. B-5. Symbolic representation of a NOT gate or an Inverter.

The complement is written by putting a bar over the alphabet. Thus \bar{A} is a complement of A . When $A=0$, $\bar{A}=1$ and $A=1$, $\bar{A}=0$. \bar{A} is read as NOT A .

For the logic of a NOT gate, we see that the output is the inverse of the input and hence a NOT gate is known as an inverter also. The symbolic representation of a NOT gate or INVERTER is shown in Fig. B-5.

TABLE B-4
Truth Table of NOR Gate

A	B	$Y = \overline{A+B}$
0	0	1
1	0	0
0	1	0
1	1	0

B-8. NOR Gate

The outputs which we get in the case of NOR gate are the complement of those which we get in the case of an OR gate.

The truth table for NOR gate is given in Table B 4.

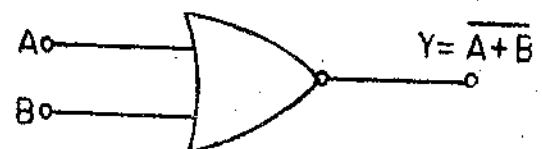

Fig. B-6. Symbolic representation of NOR Gate.

The symbolic representation of a two input NOR gate is shown in Fig. B-6.

It should be noted that $\overline{A+B}$ is a complement of $A+B$.

B-9. NAND Gate

The output from a NAND gate is a complement of the output of an AND gate for similar conditions of input. The truth table of a two input NAND gate is given in Table B-5.

TABLE B-5**Truth Table of a two Input NAND Gate**

<i>A</i>	<i>B</i>	$Y = \overline{A \cdot B}$
0	0	1
1	0	1
0	1	1
1	1	0



Fig. B-7. Symbolic representation of a NAND gate.

The symbolic representation of a two input NAND gate is shown in Fig. B-7.

Appendix C

CONVERSION FACTORS

<i>To Convert</i>	<i>Into SI</i>	<i>Multiply by</i>	<i>Conversely multiply by</i>
Length			
inches	cm	2.540	0.3937
feet	m	0.3048	3.2808
miles	km	1.6093	0.6214
micron	m	10^{-6}	10^6
Area			
inch ²	cm ²	6.452	0.1550
feet ²	m ²	0.0929	10.764
Volume			
inch ³	cm ³	16.39	0.061
feet ³	m ³	0.02832	35.31
gallon	m ³	4.546×10^{-3}	219.9
litre	m ³	10^{-3}	10^3
pin ^t	m ³	0.568×10^{-3}	1760.5
quart	m ³	1.136×10^{-3}	879.9
Velocity			
feet/second	m/s	0.3048	3.281
miles/hour	km/h	1.609	0.6215
knots	m/s	0.5144	1.943
Mass			
gramme	kg	10^{-3}	10^3
pound (lbm)	kg	0.4536	2.2046
slug	kg	14.59	0.0685
ton	kg	1016	0.9842×10^{-3}
tonne (metric)	kg	10^3	10^{-3}
Density			
gramme/cm ³	kg/m ³	10^3	10^{-3}
pound/foot ³	kg/m ³	16.02	0.0624
pound/inch ³	kg/m ³	27.678×10^9	36.123×10^{-12}
slug/foot ³	kg/m ³	515.4	1.94×10^{-3}
Force			
dyne	N	10^{-5}	10^5
kgf	N	9.807	0.102
lbf	N	4.448	0.2248

APPENDIX C

Pressure			
dyne/cm ²	N/m ²	0.1	10
kgf/cm ²	kN/m ²	98.07	0.0102
psi (lbf/inch) ²	kN/m ²	6.895	0.145
inches of water	N/m ²	249	1.014×10^{-3}
feet of water	kN/m ²	2.89	0.3345
inches of mercury	kN/m ²	386	1.2953
mm of mercury	kN/m ²	0.1333	7.502
1 torr = 1 mm of Hg			
Pascal (Pa)	N/m ²	1	1
bar	kN/m ²	100	0.01
atm	kN/m ²	101.323	98.69×10^{-3}
Energy			
erg	J	10^{-7}	10^7
foot pound	J	1.356	0.7375
calory	J	4.187	0.2388
Btu	kJ	1.055	0.9478
Power			
ergs/second	W = Nm/s = J/s	10^{-7}	10^7
foot pound/second	W	1.356	0.7376
horse power	kW	0.7457	1.341
horse power (metric)	kW	0.7355	1.360
Moment of Inertia			
pound foot ²	kg-m ²	0.0421	23.75
pound inch ²	kg-m ²	0.2926×10^{-3}	3.418×10^3
slug foot ²	kg-m ²	1.355	0.7375
Discharge			
cusecs (ft ³ /s)	m ³ /s	0.02832	35.33
gpm (gallons/min)	m ³ /s	3.0758×10^{-3}	0.3251×10^{-3}
litre/second	m ³ /s	10^{-3}	10^3
pound/second	kg/s	0.4536	2.204
Viscosity			
Poise (P)	Ns/m ²	0.1	10
centipoise (cP)	Ns/m ²	0.01	1000
Stoke (St)	m ² /s	10^{-4}	10^4
centistock (cSt)	m ² /s	10^{-6}	10^6
Thermal Conductivity			
Btu/ft-hour-°F	W/m-°C	1.7307	0.5778
k cal/m-hour-°C	W/m-°C	1.663	0.86
Entropy, Specific Heat, Latent Heat			
Btu/lb-°R	kJ/kg-°K	4.187	0.2388
Btu/lb	kJ/kg	2.326	0.423
k cal/kg	kJ/kg	4.187	0.2388
Heat Transfer Coefficients			
Btu/ft ² -hour-°F	W/m ² -°C	5.678	0.1760
k Cal/m ² -hour-°C	W/m ² -°C	1.163	0.86

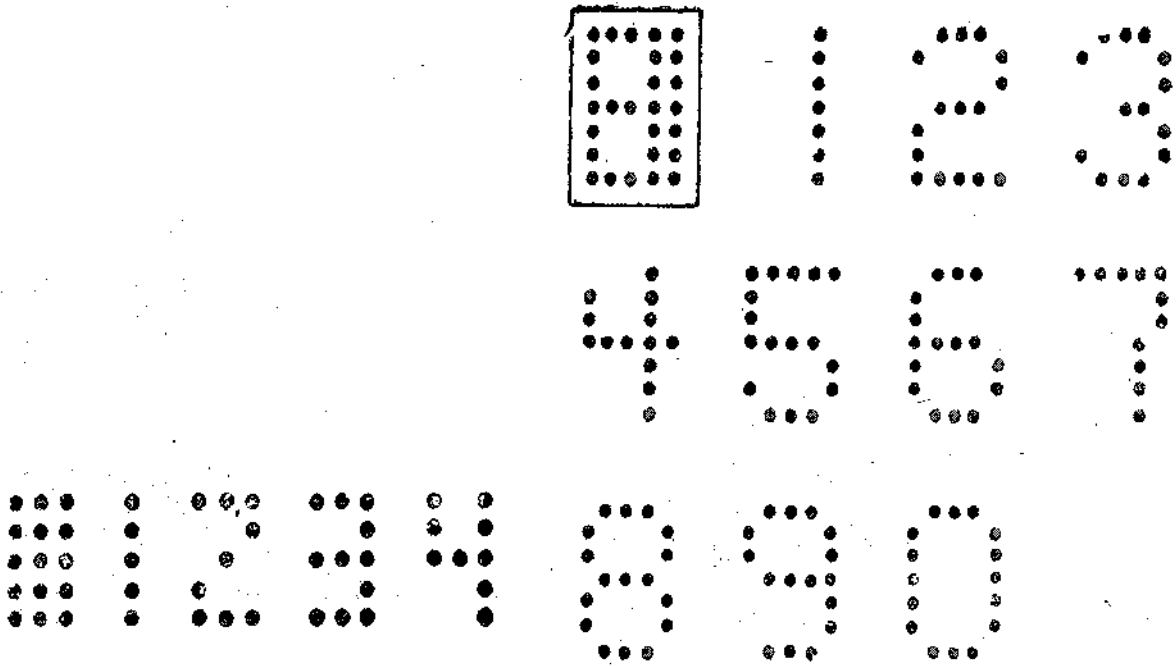

(a) 3x5 Dot Matrix (b) Numeric characters 1, 2, 3, 4

Fig. 28'10. A 3x5 Dot Matrix and formation of numeric characters

Fig. 28'11. Digital display unit with grid illuminated dots.

28'8'3. A 5x7 Dot Matrix. For display of Alphanumeric characters a 5x7 dot matrix is used as shown in Fig. 28'12.

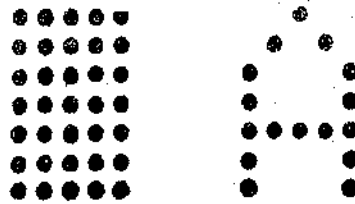

(a) 5x7 Dot Matrix (b) Alphabet A

Fig. 28'12. A 5x7 Dot matrix and alphabet 'A'.

28'9. Rear Projection Display. A cutout view of a typical rear projection display is shown

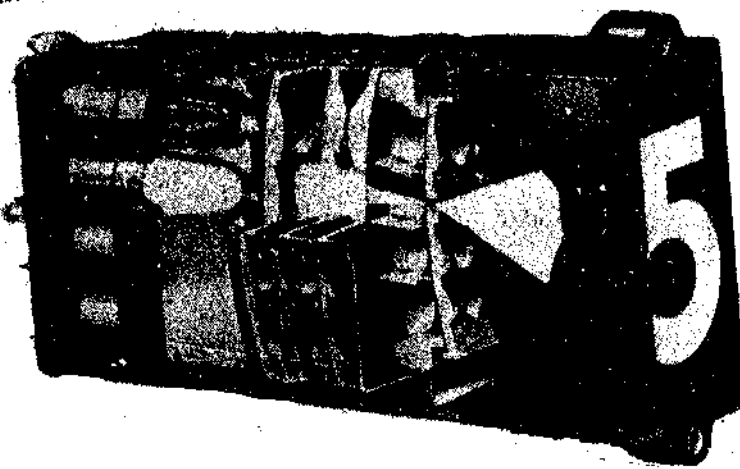

Fig. 28'13. Rear projection display.



Fig. 28'14. Nixie tube.

in Fig. 28'13. Each of the 12 incandescent lamps when energized by the input signal illuminates a different part of the filmstrip. The lens system projects the illuminated part of the film onto a viewing screen. The rear projection is slower than NIXIE (discussed later). It requires a lower voltage (6.3-28 V) and dissipates between 1 to 3 W. Nixie uses a voltage of about 170-300 V and dissipates about 0.5 W.

28'10. Nixie Tube

Another non-planar display device is the nixie. It is a gaseous glow tube having a set of electrodes, each shaped in the form of a digit. The selected electrode (3 as shown in Fig. 28'14) is surrounded by a gaseous discharge, or glow when the digit is selected. The electrodes are stacked one behind the other; and hence the various digits appear in different planes in the readout.

28'11. Light Emitting Diode (LED)

A relatively new family of display devices utilizes "light emitting diodes". The LED is perhaps the most important of the display devices available today for use in Instrumentation systems. The LED is a PN junction device which emits light when a current passes through it in the forward direction.

Charge carrier recombination occurs at a PN junction as electrons cross from N side and recombines with holes on the P side. When recombination takes place, the charge carriers give up energy in the form of heat and light. If the semiconducting material is translucent the light is emitted, and the junction is source of light. This is the light emitting diode *i.e.* LED.

Fig. 28'15 (a) shows a cross-sectional view of a typical LED charge carrier recombinations takes place in the P type material. Therefore, the P region becomes the surface of the devices. For maximum light emission, a metal film anode is deposited around the edge of the P type material. The cathode connection for the device is usually a gold film at the bottom of the N type region. This helps in reflecting the light to the surface.

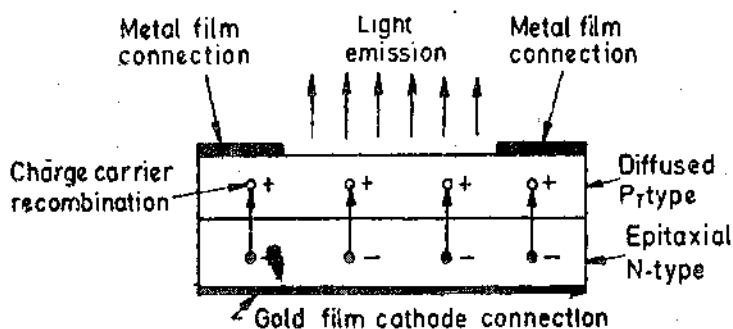

Fig. 28'15. (a) LED cross-section

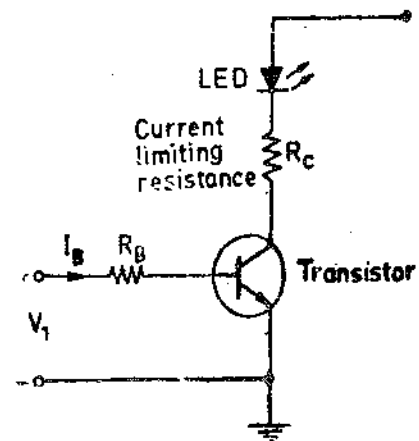

Fig. 28'15 (b) LED controlled by a transistor switch

Semiconductor material used for manufacture of LED is gallium arsenide phosphide (GaAs P) which emits red or yellow light of gallium arsenide (GaAs) which gives green or red light emission. LEDs are used extensively in segmental and dot matrix displays of numeric and alphanumeric characters. Several LEDs are used in series to form one segment while a single LED may be used to form a decimal point. LEDs are available in many colours like green, yellow, amber and red.

A simple transistor can be used for OFF/ON of an LED as shown in Fig. 28'15 (b). When the transistor is driven into saturation by base current I_B , it conducts heavily (switch is closed and the LED emits light). The LED current is limited by a resistance R_C .

The major advantages of LEDs in electronic displays are :

(i) LEDs are miniature in size and they can be stacked together to form numeric and alphanumeric displays in high density matrix.

(ii) The light output from an LED is a function of the current flowing through it. Therefore intensity of light emitted from LEDs can be smoothly controlled.

(iii) LEDs have a high efficiency as emitters of electromagnetic radiation. They require moderate power for their operation. A typical voltage drop of 1.2 V and a current of 20 mA is required for full brightness. Therefore, LEDs are useful where miniaturization with low d.c. power are important.

(iv) LEDs are available which emit light in different colours like red, green, yellow and amber.

(v) The switching time (both on and off) is less than 1 ns and therefore they very useful where dynamic operation of large number of arrays is involved.

(vi) LEDs are manufactured with the same type of technology as is used for transistors and ICs and therefore they are economical and have a high degree of reliability.

(vii) LEDs are rugged and can therefore withstand shocks and vibrations. They can be operated over a wide range of temperature say 0–70 °C.

The disadvantage of LEDs as compared with LCDs is their high power requirement. Also LEDs are not suited for large area displays, primarily because of their high cost. For large displays, devices using gas filled plasma are used.

28.12. Liquid Crystal Diodes (LCD)

Liquid crystal cell displays (LCDs) are used in similar applications where LEDs are used. These applications are display of numeric and alphanumeric characters in dot matrix and segmental displays.

The LCDs are of two types :

- (i) Dynamic scattering type, and (ii) Field effect type.

The construction of a dynamic scattering liquid crystal cell is shown in Fig. 28.16. The liquid crystal material may be one of the several organic compounds which exhibit optical properties of a crystal though they remain in liquid form. Liquid crystal is layered between glass sheets with transparent electrodes deposited on the inside faces.

When a potential is applied across the cell, charge carriers flowing through the liquid disrupt the molecular alignment and produce turbulence. When the liquid is not activated, it is transparent. When the liquid is activated the molecular turbulence causes light to be scattered in all directions and the cell appears to be bright. The phenomenon is called **dynamic scattering**

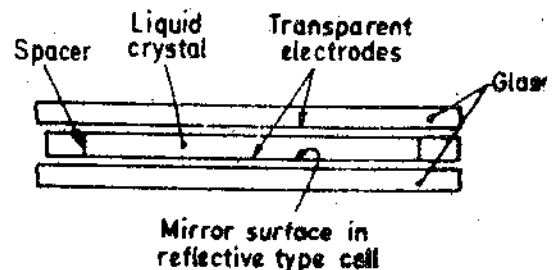

Fig. 28.16. Liquid crystal diode cell (LCD).

The construction of a field effect liquid crystal display is similar to that of the dynamic scattering type, with the exception that two thin polarizing optical filters are placed at the inside of each glass sheet. The liquid crystal material in the field effect cell is also of different type from that employed in the dynamic scattering cell. The material used is twisted nematic type and actually twists the light passing through the cell when the latter is not energized. This allows the light to pass through the optical filters and the cell appears bright. When the cell is energized, no twisting of light takes place and the cell appears dull.

Liquid crystal cells are of two types.

- (i) Transmittive type, and (ii) Reflective type.

In the transmittive type cell, both glass sheets are transparent, so that light from a rear source is scattered in the forward direction when the cell is activated.

The reflective type cell has a reflecting surface on one side of glass sheets. The incident light on the front surface of the cell is dynamically scattered by an activated cell. Both types of cells appear quite bright when activated even under ambient light conditions.

The liquid crystals are light reflectors or transmitters and therefore they consume small amounts of energy (unlike light generators). Considering the case of seven segmental display, the current is about 25 μ A for dynamic scattering cells and 300 μ A for field effect cells. Unlike LEDs which can work on d.c. the LCDs require a.c. voltage supply. A typical voltage supply to dynamic scattering LCD is 30 V peak to peak with 50 Hz.

The advantages of LCDs are :

- (i) They have a low power consumption. A seven segmental display requires about 140 μ W (20 μ W/segment). This is great advantage over LEDs which require about 40 mW per numeral.
- (ii) They have a low cost.

The chief disadvantages of LCDs are :

- (i) LCDs are very slow devices. The turn on and the turn off times are quite large. The turn on time is typically of the order a few milliseconds while the turn-off is ten milliseconds.
- (ii) When used on d.c. their life span is quite small. Therefore they are used with a.c. supplies having a frequency less than 50 Hz.
- (iii) They occupy a large area.

On account of the reasons described above LCDs are normally used for seven segmental displays.

28.13. Nixie Tube

The basic construction of a digital indicator tube is shown in Fig. 28.17. It is a cold cathode glow discharge tube, which is popularly known as Nixie which is the trade mark of M/s Burrough's Corporation U.S.A. The display works on the principle that when a gas breaks down, a glow discharge is produced. A gauze electrode with a positive voltage supply functions as an anode, and there are 10 separate wire cathodes, each in the shape of a numeral from 0 to 9. The electrodes are enclosed in a glass filled envelope with connecting pins at the bottom. Neon gas is usually employed and it gives an orange-red glow when activated. However, other colours are available when different gases are used.

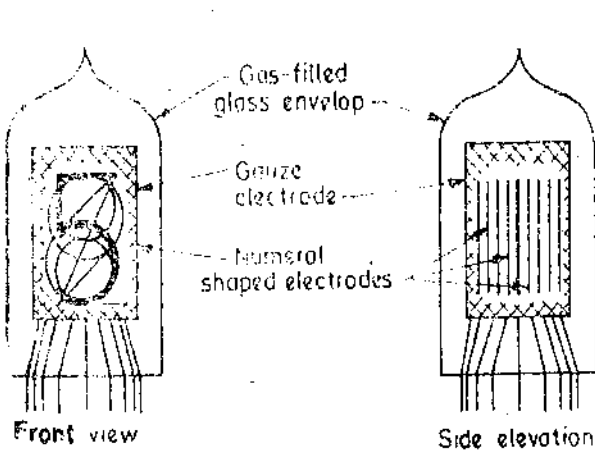

Fig. 28.17. Nixie tube.

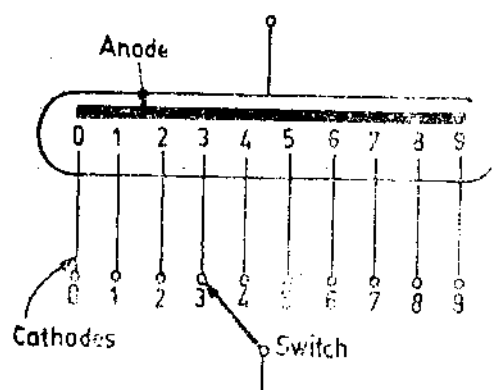

Fig. 28.18. Schematic symbol of Nixie.

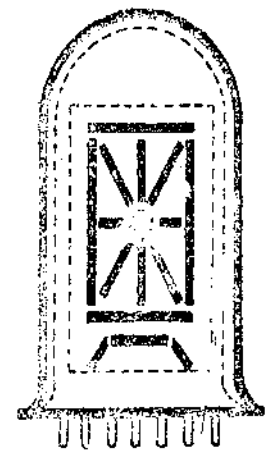

Fig. 28.19. Fifteen segment Nixie.

There is one anode and 10 cathodes. After a negative voltage is applied to the selected cathode, a simple gas discharge diode is formed which lights the selected digit.

A transistor gate is usually employed at each cathode so that the desired numeral can be switched on

The circuitry driving the nixie tubes is simpler than that for seven segment displays. However, high voltages (150–22 V) are required to produce glow discharge. The current required is of the order of 1–5 mA. The Nixie tubes are bulkier in size than the seven segmental displays.

Modern Nixies. Modern Nixies vary in construction. The original Nixie had 10 cathodes representing numerals 0–9 but additional cathodes displaying decimal symbol and + and – signs are being used.

Special Nixies (Burroughs B 7971, shown in Fig. 28'19) have 15 cathodes constituting 15 segments that be used to produce numeric as well as alphanumeric characters.

28'14. Segmental Gas Discharge Displays. Gas discharge displays are available in seven-segment or fourteen-segment format for display of numeric and alphanumeric characters. They can be built up to operate on the gaseous discharge glow principle as Nixies do. Integrated circuits (ICs) have been developed to drive these devices and to develop the high voltages involved. The construction of a seven segment gas discharge display is shown in Fig. 28'20. It is seen that separate cathodes are provided in seven segments (and decimal point) form on a base. Each seven segment group has a single anode deposited on the covering face plate. The gas is contained in the space between anodes and cathodes. The connections are provided with the help of pins for all electrodes at the rear. A keep alive cathode is also enclosed with each group of segments.

A 50 μ A current maintained through the keep alive cathode provides a source of ions. This improves the switching speed of the display.

The most serious disadvantage of the gas discharge displays is the high voltage required to operate them. This voltage is between 150 V to 220 V. High voltage transistors must be employed as switches for the cathodes. In fact, a separate high voltage supply is required for this purpose. However, a major advantage that offsets the disadvantages given above is that we can have bright

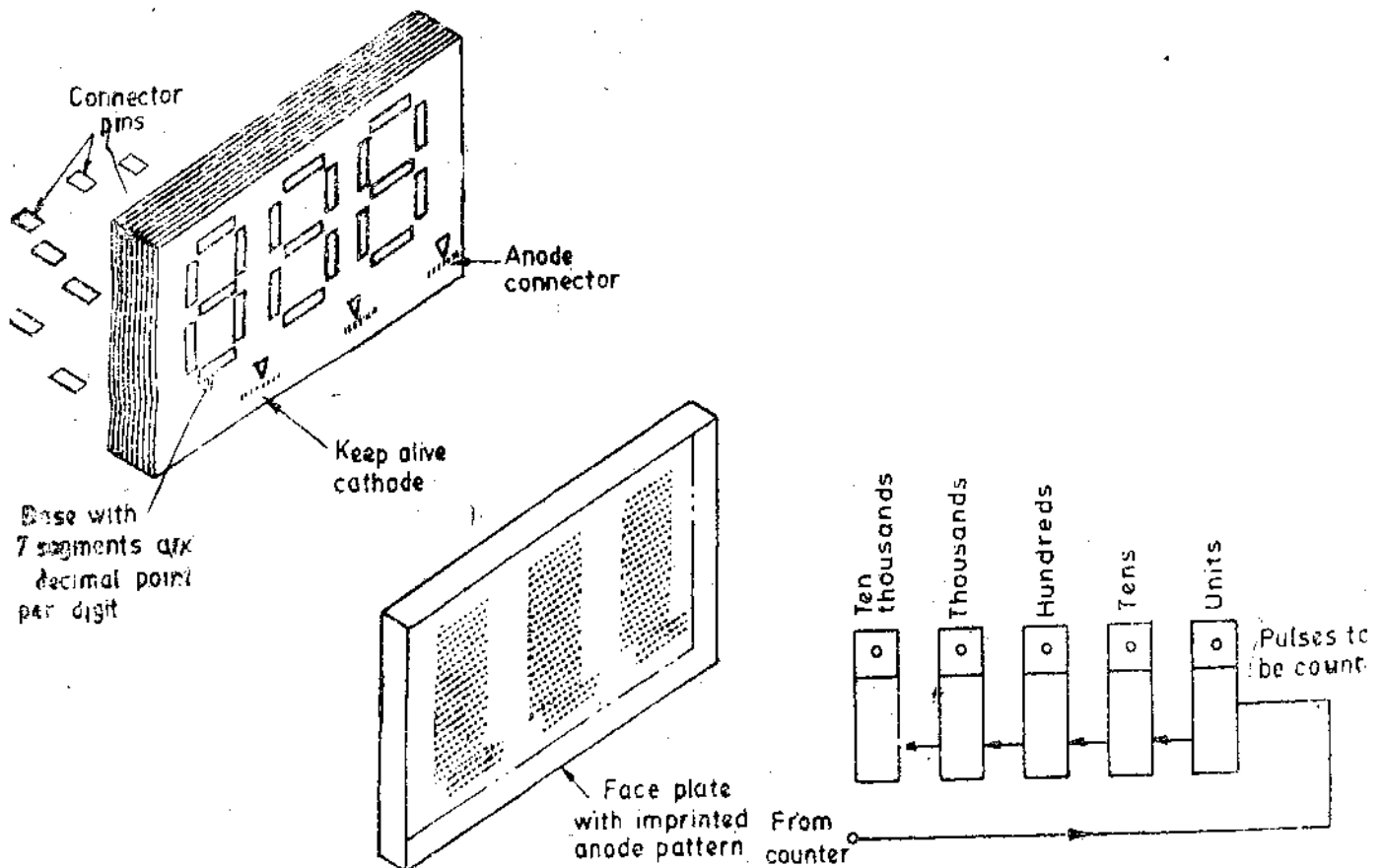

Fig. 28'20. Seven segmental display using gaseous discharge. Fig. 28'21. Decade counting assemblies (DCAs) with their readout.

displays with tube currents as low as 200 μ A. Therefore the drain on power supply is extremely small.

28'15. Decade Counting Assemblies (DCAs)

A single numeric display unit can display numbers from 0 to 9. This is called a Decade Counting Assembly (DCA).

Modern electronic counters use triggering units along with decade counting assemblies and display devices to totalize and display the count.

A typical decimal indicating system uses 10 characters to display numbers 0 to 9. Ten trigger circuits are needed for each decade counting assembly (DCA). A pulse from first trigger actuates circuit of 1 to indicate the first event counted. The second event triggers the second circuit, displaying 2 and feeds a pulse back to the first circuit, for it to turn off. This sequence continues upto a count of 9, and the decade recycles. However, in practice, a single decade is not used but a number of DCAs connected in cascade, are used as shown in Fig. 28'21.

Fig. 28'21 shows 5 decade counting assemblies connected in cascade. They can count upto 99999. When the first unit counts upto 9, it returns to 0 on the 10th count and activates 1 of the 2nd (tens decade) with DCA indicating a count of 10.

When the tens decade recycles, it activates 1 of the 3rd (hundreds decade) DCA. As each decade recycles and activates the higher DCA.

Thus this readout does not require any interpolation and the number is clearly displayed.

28'16. Display Systems. Electronic displays serve as output units of instrumentation systems. The digital data resulting from a measurement application is binary coded decimal (BCD)* form. Thus in display applications, where machine communicates with a human being some sort of **Decoding** is required. If the language of the machine is BCD, we have to decode (translate) it into a decimal code than can be easily understood by the human operator. In many cases, decoding binary into octal might facilitate man machine communications. The decoder converts the binary code, such as BCD, into a non binary code that can be understood by man, such as decimal or 7-segment code. The decimal code has 10 different symbols while the 7 segment code has 7 separate lines used in activating 7 segment decimal displays.

We have discussed earlier that there are three types of display formats commonly used viz. (i) segmental (7 segment), dot matrix (5 × 7 matrix) and decimal indicator (Nixie tube). Thus each of these formats require the use of an appropriate code converter between the BCD data input and the output display. The code converter for operating Nixie tube has simply to be a 10 position switch which operates in accordance with the input code and therefore it is simply a decoder. However, in the case of segmental and dot matrix displays, a suitable decoder-encoder combination is used.

In the case of a Nixie tube there is one anode and 10 cathodes, each shaped like the digit to be displayed. A typical Nixie circuit is shown in Fig. 28'22. Grounding a particular cathode causes the neon gas around that cathode to ionize and the digit is displayed on account of the resulting glow.

In the case of segmental displays, one or more than one light sources may be involved in the display of a particular character. Supposing digit 0 is to be displayed by a 7 segment display as shown in Fig. 28'23. This requires that segments *a*, *b*, *c*, *d*, *e* and *f* should be lit up. Similarly for digit 2, segments *a*, *b*, *d*, *e* and *g* should be lit up. Thus by properly choosing the segments any number from 0 to 9 can be displayed.

A common supply voltage drives the anodes of the LEDs and when a switch closes, the corresponding LED is forward biased and emits light.

* For BCD See Appendix A.

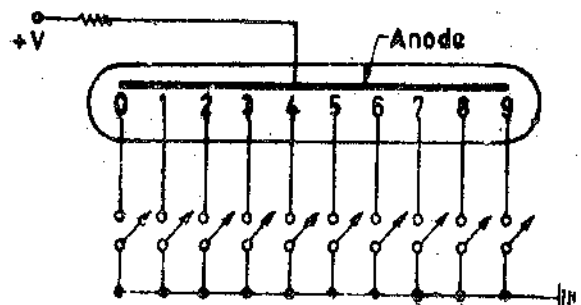

Fig. 28'22. Display system of Nixie tube.

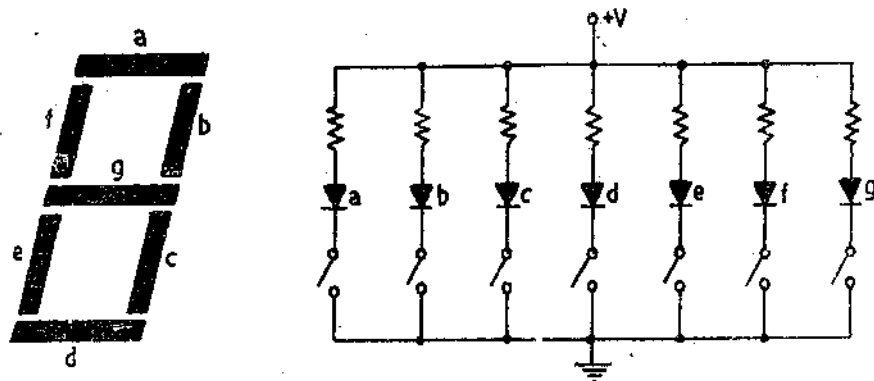

Fig. 28-23. Seven segment readout and circuit.

Fig. 28-24 shows a typical 5×7 dot matrix using LEDs. In order to light an LED in this matrix, a voltage has to be applied to its anode and its cathode has to be grounded. In Fig. 28-24 the circled LED lights up because a voltage is applied to 3rd row and 5th column. By applying voltage to more than one column and grounding more than one row, a decimal digit or alphabet can be displayed.

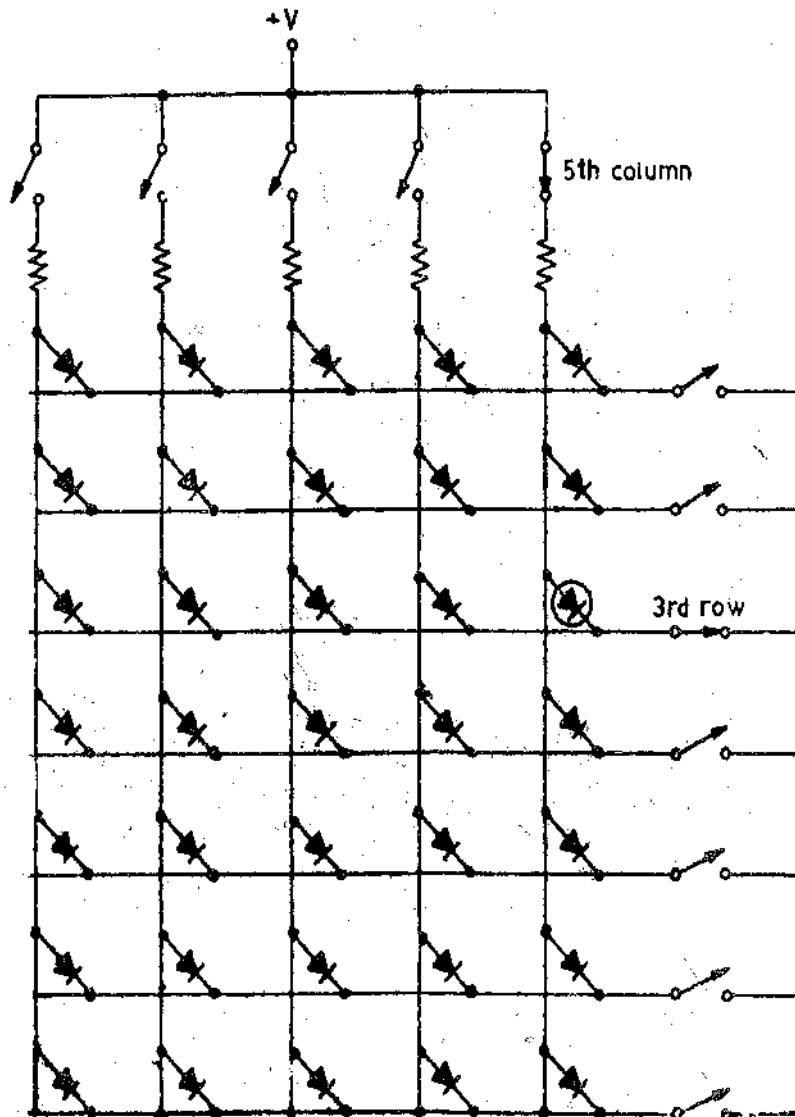

Fig. 28-24. A 5×7 LED matrix.

20-17. Decimal Decoders. A variety of codes are possible for the binary representation of

decimal numbers. The 8-4-2-1 and 2-4-2-1 BCD codes are popular for BCD display system applications. Only conversion of 8-4-2-1 BCD code into decimal system is discussed here. This can be done by using a diode matrix or logic gates such as TTL (Transistor transistor logic).

28 171. Diode. One number system may be converted into another number system with the help of a diode matrix circuit. For example BCD number system can be converted into a decimal readout by using the diode matrix circuit of Fig. 28'25. Switches 1, 2, 4 and 8 provide input to

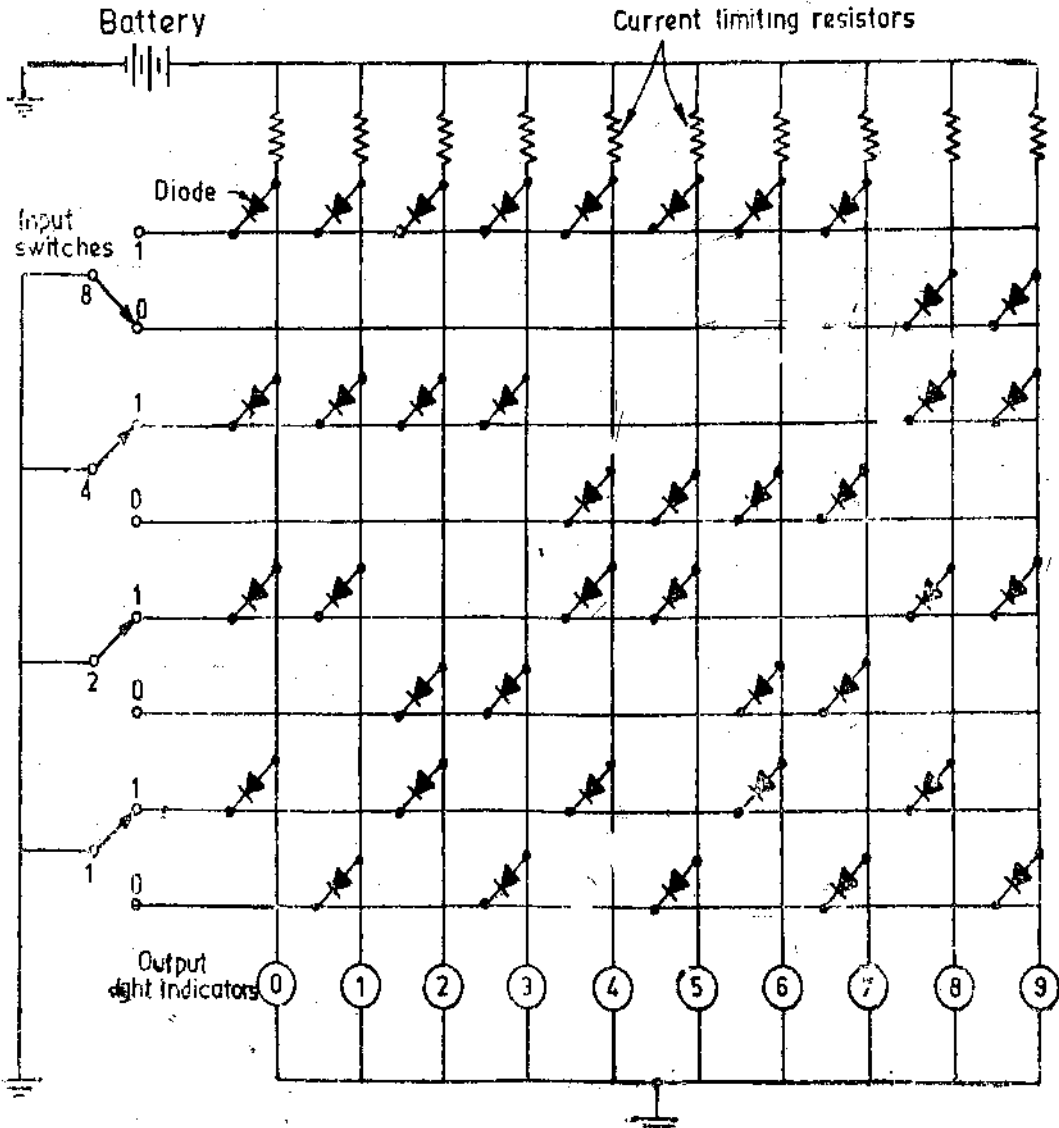

Fig. 28'25. Diode matrix circuit for conversion of BCD system to decimal readout.

the matrix and the decimal indicators 0 to 9 are the output of the matrix. In order to energize an output decimal indicator, the connection from the battery to the indicator must not be connected to ground through a diode as under these conditions the diode will short the indicator.

Fig. 28'25 shows how number 7 is indicated. For number 7 to be indicated corresponding to a BCD input, switch 8 should be at its 0 position, switch 4 should be at its 1 position, switch 2 should be at its 1 position, and switch 1 should be at its 1 position. Under these conditions :

- Switch 8 shorts indicators 8 and 9,
- Switch 4 shorts indicators 0, 1, 2, 3, 8 and 9,
- Switch 2 shorts indicators 0, 1, 4, 5, 8 and 9,
- Switch 1 shorts indicators 0, 2, 4, 6 and 8,

Thus all the indicators with the exception of 7 are short circuited. Thus only light indicator 7 will be lit. Thus the readout is 7.

This way any number can be indicated. The number 0 is indicated when all the input switches are in 0 position.

This system may be used for Nixie tubes.

28 17 2 TTL Logic. The 7400 series, a line of circuits introduced in 1964, has become the most widely used group of bipolar ICs. Various decoders are available (See Texas Instruments Inc., 7441 through 7448 in the TTL 7400 series). Electrical characteristics such as input loading, output drive capability and switching characteristics do not vary within specific family of devices. The variations mostly involve drive capabilities tailored to suit particular loads *i.e.* Nixie tubes, 7 segmental displays, LED displays etc.

A typical truth table and logic diagram for a 8-4-2-1 BCD to decimal decoder is shown in Fig. 28.26. The circuit uses NAND* gates as is commonly done in TTL ICs. The active level for outputs is logic '0' (inverted output) while for the inputs it is logic 1. In the inverted output logical 0 is true while logical 1 is false. (Negative logic is used). All the input states are explicitly decoded. The codes representing numbers 10 to 15 (*i.e.* BCD 1010 to 1111) result in all the output being false or logical 1 as shown in the truth table.

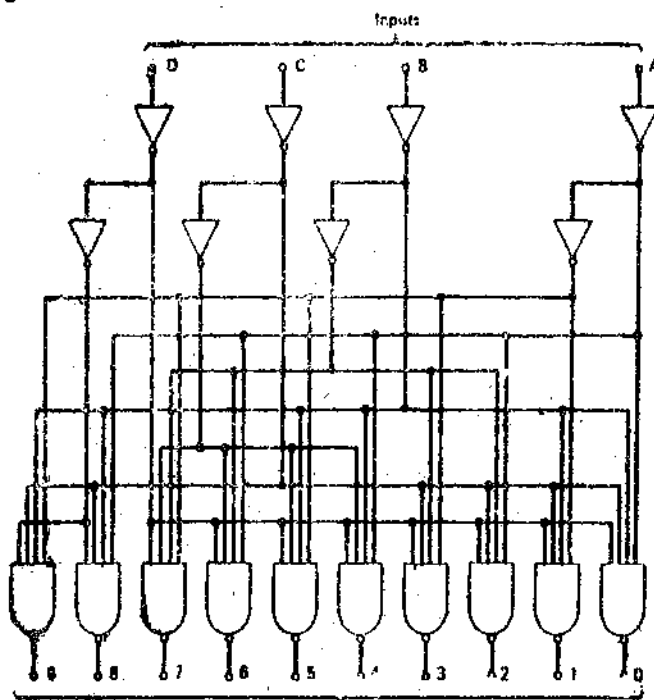

(a)

BCD Input				Decimal Output									
D	C	B	A	0	1	2	3	4	5	6	7	8	9
0	0	0	0	1	0	0	0	0	0	0	0	0	0
0	0	0	1	0	1	0	0	0	0	0	0	0	0
0	0	1	0	0	1	1	0	0	0	0	0	0	0
0	0	1	1	0	1	1	1	0	0	0	0	0	0
0	1	0	0	0	1	1	1	1	0	0	0	0	0
0	1	0	1	0	1	1	1	1	1	0	0	0	0
0	1	1	0	0	1	1	1	1	1	1	0	0	0
0	1	1	1	0	1	1	1	1	1	1	1	0	0
1	0	0	0	0	1	1	1	1	1	1	1	1	0
1	0	0	1	0	1	1	1	1	1	1	1	1	1
1	0	1	0	0	1	1	1	1	1	1	1	1	1
1	0	1	1	0	1	1	1	1	1	1	1	1	1
1	1	0	0	0	1	1	1	1	1	1	1	1	1
1	1	0	1	0	1	1	1	1	1	1	1	1	1
1	1	1	0	0	1	1	1	1	1	1	1	1	1
1	1	1	1	0	1	1	1	1	1	1	1	1	1

(b)

(a) Logic diagram (b) Truth table
Fig. 28.26. BCD-to-decimal decoder.

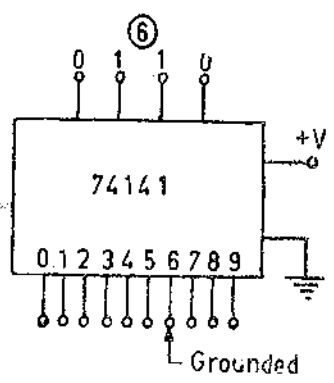
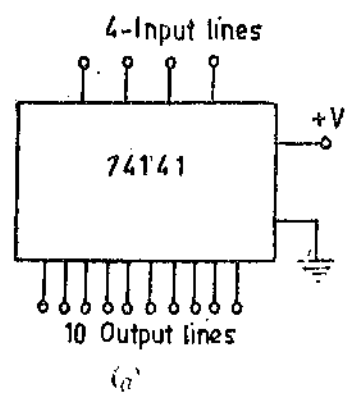

Fig. 28.27. 74141 BCD-to-decimal decoder.

*See Appendix B.

Any of these codes may be used to blank the output—that is to ensure that none of the display indicators are on. This is useful for leading and trailing zeros. For example, in the number 000486 the first three zeros ought to be blanked. Similarly trailing zeros in 6'3000 have no significance.

A 74141 (belonging to 7400 series) is a BCD to decimal decoder. It can be used to drive a discrete display device like Nixie. In Fig. 28'27 (a) a supply voltage V is applied to one of the pins on the right while the second pin is connected to ground. When a BCD input drives the four input lines, one of the 10 output lines will be internally grounded. For example in Fig. 28'27 (b), when the input is 0110, the 6th output line is grounded.

A 74141 decoder is needed for each BCD digit. Fig. 28'28 shows four 74141s decoding a BCD digit :

1001 0101 0010 0110 that represents a decimal number 9526.

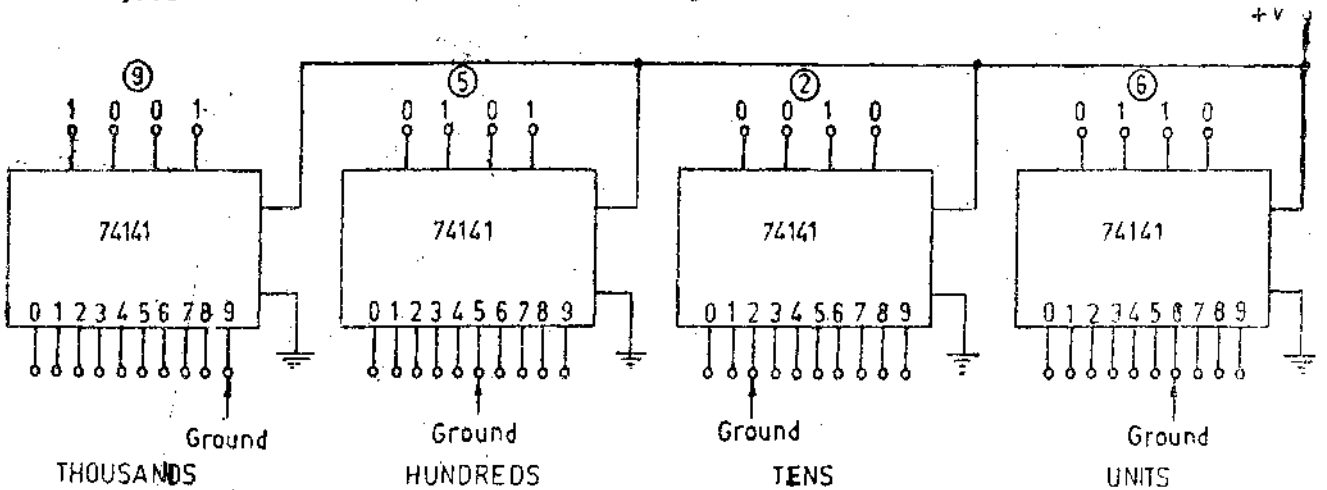

Fig. 28'28. Decoding four BCD digits.

Since each 74141 functions as a BCD-to-decimal converter, the thousands decoder grounds 9th output line, the hundreds decoder grounds 5th output line, the tens decoder grounds the 2nd output line while the units decoder grounds the 6th output line.

28'18. BCD to 7-Segment Converter. A BCD-to-7 segment converter is required to convert a four bit BCD input to control the outputs for driving a 7 segment numeric characters such as those which use LEDs and LCDs.

The conversion of 8-4-2-1 BCD code to 7 segment code is given in Table 28'1 (Refer to Fig. 28'23).

TABLE 28'1
BCD to 7-Segment Code Conversion

Decimal Number	BCD Code				7 Segment Output						
	D	C	B	A	a	b	c	d	e	f	g
0	0	0	0	0	1	1	1	1	1	1	0
1	0	0	0	1	0	1	1	0	0	0	0
2	0	0	1	0	1	1	0	1	1	0	1
3	0	0	1	1	1	1	1	1	0	0	1
4	0	1	0	0	0	1	1	0	0	1	1
5	0	1	0	1	1	0	1	1	0	1	1
6	0	1	1	0	0	0	1	1	1	1	1
7	0	1	1	1	1	1	1	0	0	0	0
8	1	0	0	0	1	1	1	1	1	1	1
9	1	0	0	1	1	1	1	0	0	1	1

The output (segment select) code is logic 1 type *i.e.* positive logic used. However, inverted type (the complement of code with active 1's) may also be used where it is logic 0. The inverted 7 segment logic is obtained by interchanging 0's and 1's.

In addition to 10 BCD inputs 0000 through 1001 representing decimal numbers 0 through 9, selected symbols may be used 6 additional inputs *i.e.* 1010 to 1111. Since 16 characters of 7 bit output code are handled by this code converter, it is also called a 16x7 converter. The converter using NAND gates which are ideally suited for TTL IC configuration is shown in Fig. 28'29. Since all the 16 states from 0000 to 1111 are acceptable, there is 'false data rejection'.

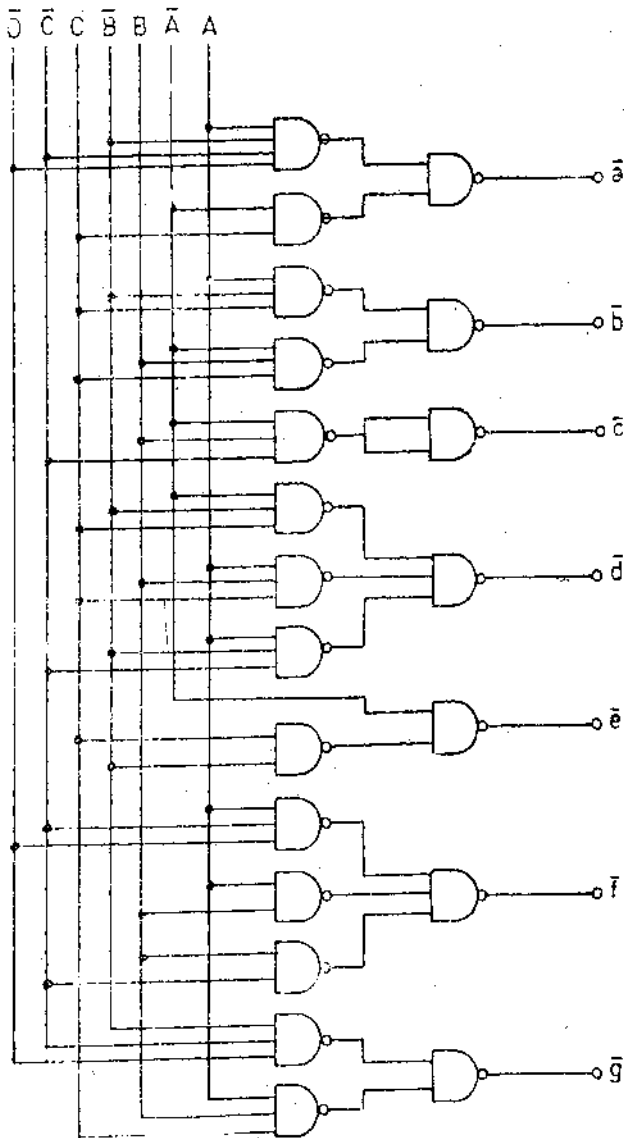

Fig. 28'29. BCD to 7 segment converter.

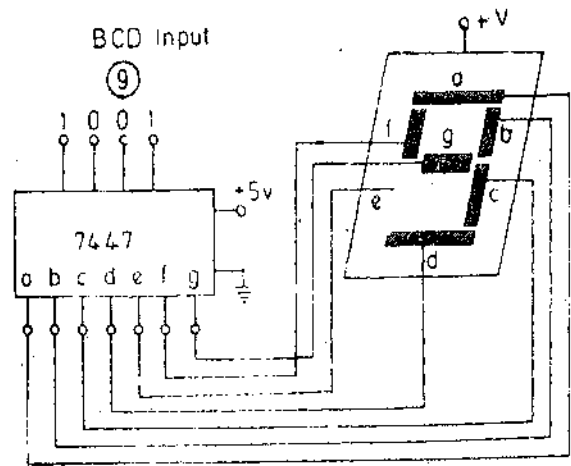

Fig. 28'30. 7447 BCD-to-7 segment decoder.

The 7447 is a BCD-to-7 segment converter. It has four inputs for the BCD and 7 outputs for driving 7 segmental displays. For a given BCD input it grounds the appropriate 7 segment LED display. For example if the BCD input is 1001 (9), it grounds the *a, b, c, f* and *g* output lines. These grounds then activate segments *a, b, c, f* and *g* to display digit 9 as shown in Fig 28 30.

The display of a 5 digit decimal number say 48572 will require one 7447 and a seven segment display for each of the five digits. Thus five 7447s and five 7 segment displays will be needed. With this arrangement all the five digits are excited simultaneously.

However, multiplexing can be used to reduce the number of decoders, wiring and the displays.

In the arrangement using multiplexing, instead of activating all the digits simultaneously, we can display them in rapid succession. If this is done at a highly fast rate all the digits would be displayed without flicker as shown in Fig. 28.31.

28.19. BCD-to-Dot Matrix Converter. A 3x5 dot matrix is required for display of numeric characters while the display of alphanumeric characters requires a 5x7 dot matrix. A 4 bit BCD input is required for conversion to appropriate dot selection code which will activate the dots to display the character. Considering 16 characters are to be accommodated in the input code a converter of 16x35 bits capacity is required for 3x5 dot matrix while the converter capacity is 16x35 bits for a 5x7 dot matrix. A six bit code is required for display of alphanumeric characters as there are 26 alphabets, 10 decimal number and 28 special characters totalling 64. Thus the capacity of alphanumeric code converter is 64x35 bits. These code conversions are done through special building blocks called read-only memory (ROM).

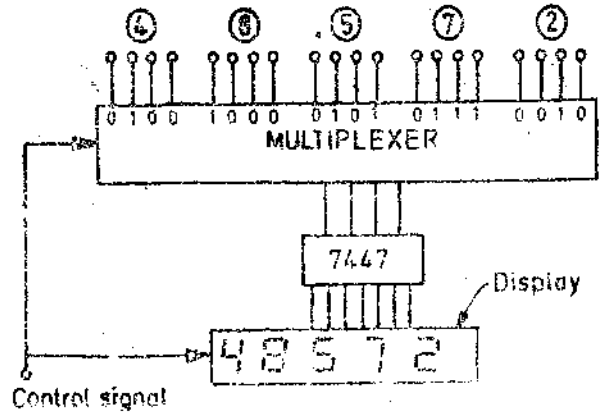

Fig. 28.31. Multiplexing and digital display.

A 5x7 LED dot matrix is shown in Fig. 28.24. All the LEDs required for display of a character are not illuminated simultaneously. Usually they are activated a row at a time. For example the first row of LEDs is first grounded and voltage is applied to the appropriate columns. After displaying for a short interval, the second row of LEDs is grounded and voltages applied to the appropriate columns. The third and subsequent rows are grounded successively with voltages applied to required columns. This process is repeated at a very fast rate, so that the character is displayed without flicker.

The circuits driving the dot matrix converter scan through the rows and apply voltages to appropriate columns at the same time. Therefore the circuitry is complex. A ring counter scans the rows, while a read-only memory (ROM) applies voltages to columns.

28.20 Resolution in Digital Meters

The number of digit positions (or simply, the number of digits) used in a digital meter determines the resolution. Thus a three digit display on a digital voltmeter (DVM) for 0-1 V range will be able to indicate values from zero to 999 mV, with smallest increment or resolution of 1 mV.

In practice a fourth digit usually capable of indicating either 0 or 1 only, is placed to the left of active digits. This permits going above 999 to 1999 to give overlap between ranges for convenience. This is called **over ranging**. This type of display is known as a **3½ digit display**. Fig. 28.32 shows a Phillips 3½ digit autoranging portable digital multimeter. The resolution of a digital meter, however, is determined by the number of active or full digits used.

$$\text{If } n = \text{number of full digits, Resolution} = 1/10^n \quad \dots (28.1)$$

Therefore a 4 digit display has a resolution of $1/10^4 = 0.0001$ or 0.01 percent. This resolution is also referred to as one part in 10,000.

28.21. Sensitivity of Digital Meters

Sensitivity is the smallest change in input which a digital meter is able to detect. Therefore it is lowest voltage range's full scale value multiplied by the meter's resolution.

$$\text{Sensitivity } S = (f.s.)_{min} \times R \quad \dots (28.2)$$

where $(f.s.)_{min}$ = lowest full scale value of meter
and R = resolution expressed as decimal.

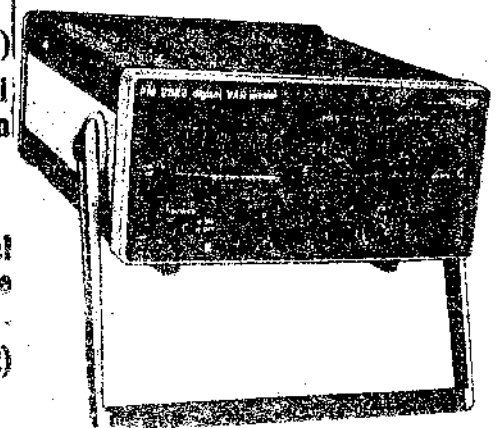

Fig. 28.32. Digital multimeter.

28.22. Accuracy Specification for Digital Meters

Accuracy is usually expressed as a percentage of the reading plus a percentage of full scale. Often the percentage of full scale part of the statement is given in terms of digits. When this is done, the digits referred to are the least significant digits (LSD).

Example 28.1. (a) What is the resolution of a $3\frac{1}{2}$ digits display? (b) Find the resolution of a $3\frac{1}{2}$ digit meter in case its range is 1 V. (Some manufacturers may specify the range as 2 V since a $3\frac{1}{2}$ digit meter can count upto 19.99 mV). (c) Find the resolution of the meter for 10 V range.

Solution. (a) Number of full digits in case of $3\frac{1}{2}$ digits display = 3.

\therefore Resolution = $1/10^n = 1/10^3 = 0.001$ or 0.1%.

Hence the meter cannot distinguish between values that differ from each other by less than 0.001 of full scale.

(b) Full scale reading = 1.000 \therefore Resolution on 1 V range = $1 \times 0.001 = 0.001$ V.

Hence on 1 V range it will not be able to distinguish between readings which differ by less than 0.001 V.

(c) Full scale reading = 10.00 \therefore Resolution on 10 V range = $10 \times 0.001 = 0.01$ V.

Hence on 10 V scale it will not be able to distinguish between readings which differ by less than 0.01 V.

Example 28.2. A $4\frac{1}{2}$ digit voltmeter is used for voltage measurements. (a) Find its resolution. (b) How would 12.98 V be displayed on 10 V range? (c) How would 0.6973 be displayed on 1 V range? (d) How would 0.6973 be displayed on 10 V range?

Solution. (a) Number of full digits on a $4\frac{1}{2}$ digit display = 4.

\therefore Resolution = $1/10^4 = 0.0001$ or 0.01%.

(b) There are 5 digit places in a $4\frac{1}{2}$ digit display. Therefore 12.98 V will be displayed as 12.980 on its 10 V scale.

(c) Resolution on 1 V range = $1 \times 0.0001 = 0.0001$ V.

Therefore on 1 V range, any reading can be displayed to 4th decimal place. Hence 0.6973 V will be displayed as 0.6973 on 1 V range.

(d) Resolution on 10 V range = $10 \times 0.0001 = 0.001$ V.

Therefore on 10 V range readings can be displayed only upto 3rd place of decimal. Hence 0.6973 V will be displayed as 0.697 on 10 V scale. The digit 3 in the fourth decimal place will be lost. Using the appropriate range i.e. 1 V, the digit 3 can be retained in the readout.

Example 28.3. A $3\frac{1}{2}$ digit DVM has an accuracy specification of ± 0.5 percent of reading ± 1 digit.

(a) What is the possible error in volt, when the instrument is reading 5.00 V on the 10 V range? (b) What is the possible error in volt, when reading 0.10 V on the 10 V range? (c) What percentage of the reading is the possible error in the case of (c)?

Solution. (a) 0.5 percent of reading = $0.005 \times 5.00 = 0.025$ V.

The display for 5.00 V read on 10 V scale of $3\frac{1}{2}$ digit meter is 05.00 as there four digit positions.

The digit in the LSD has a value 0.01 V.

\therefore Total possible error is = $0.025 + 0.01 = 0.035$ V.

(b) When reading 0.10 V on 10 V range, we have

$$\pm 5\% \text{ of reading} = 0.005 \times 0.10 = \pm 0.0005 \text{ V.}$$

$$\pm 1 \text{ digit} = \pm 0.01 \text{ V.}$$

$$\therefore \text{Total possible error} = \pm 0.0105 \text{ V.}$$

$$(c) \text{ Error as a percent of reading} = \frac{0.0105}{0.100} = 10.5\%.$$

This is a large error and demonstrates the inherent danger of taking readings low on a scale.

DIGITAL FREQUENCY METER

28.23. Measurement of Frequency

28.23.1. Principle of Operation. The signal whose frequency is to be measured is converted into a train of pulses, one pulse for each cycle of the signal. Then the number of pulses appearing in a definite interval of time is counted by means of an electronic counter. Since the pulses represent the cycles of unknown signal, the number appearing on the counter is a direct indication of frequency of the unknown signal. Since the electronic counters are extremely fast, the frequency of high frequency signals may be known.

28.23.2. Basic Circuit. The block diagram of the basic circuit of a digital frequency meter is shown in Fig. 28.33. The unknown frequency signal is fed to a Schmitt trigger.

The signal may be amplified before being applied to Schmitt trigger. In a Schmitt trigger, the signal is converted into a square wave with very fast rise and fall times, then differentiated and clipped. As a result, the output from a Schmitt trigger is a train of pulses, one pulse, for each cycle of the signal.

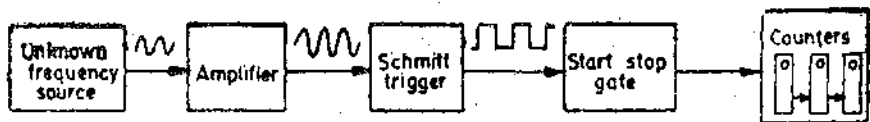

Fig. 28.33. Basic circuit of a digital frequency meter.

The output pulses from the Schmitt trigger are fed to start stop gate. When this gate opens (start), the input pulses pass through this gate and are fed to an electronic counter which starts registering the input pulses. When the gate is closed (stop), the input of pulses to counter ceases and it stops counting.

The counter displays the number of pulses that have passed through it in the time interval between start and stop. If this interval is known, the pulse rate and hence the frequency of the input signal can be known. Suppose f is the frequency of unknown signal, N the number of counts displayed by counter and t is the time interval between start and stop of gate. \therefore Frequency of unknown signal $f = N/t$.

28.23.3. Time base. It is abundantly clear that in order to know the value of frequency of input signal, the time interval between start and stop of gate must be accurately known. This time interval known as time base can be determined by the circuit given in Fig 28.34. The time-base consists of a fixed frequency crystal oscillator. This oscillator, which is known as clock oscillator must be very accurate. In order to insure its accuracy, the crystal is enclosed in a constant temperature oven. The output of this constant frequency oscillator is fed to a Schmitt trigger which converts the input to an output consisting of a train of pulses at a rate equal to the frequency of the clock oscillator. The train of pulses then passes through a series of frequency divider decade assemblies connected in cascade. Each decade divider consists of a decade counter as explained in Art. 28.4.3 on page 913 and divides the frequency by 10. Connections are taken from the output of each decade in the series chain, and, by means of a selector switch, any output may be selected.

In the block diagram of Fig. 28'34, the clock oscillator frequency is 1 MHz or 10^6 Hz. Thus the output of Schmitt trigger is 10^6 pulses per second. At the $\times 1$ tap of the switch there are 10^6 pulses per second, and thus the time interval between two consecutive pulses is 10^{-6} second or 1 μ s.

At $\times 10^{-1}$ tap, the pulses, having gone through decade divider 1, are reduced by a factor 10, and now there are 10^5 pulses per second. Therefore the time interval between them is 10 μ s. Similarly, there are 10^4 pulses per second at tap $\times 10^{-2}$ and the time interval is 100 μ s; 10^3 pulses at tap $\times 10^{-3}$ and the time interval is 1 ms; 10^2 pulses per second and tap $\times 10^{-4}$ and the time interval 10 ms, 10 pulses per second at tap $\times 10^{-5}$ and time interval 100 ms; one pulse per second at tap 10^{-6} and the time interval is 1 second.

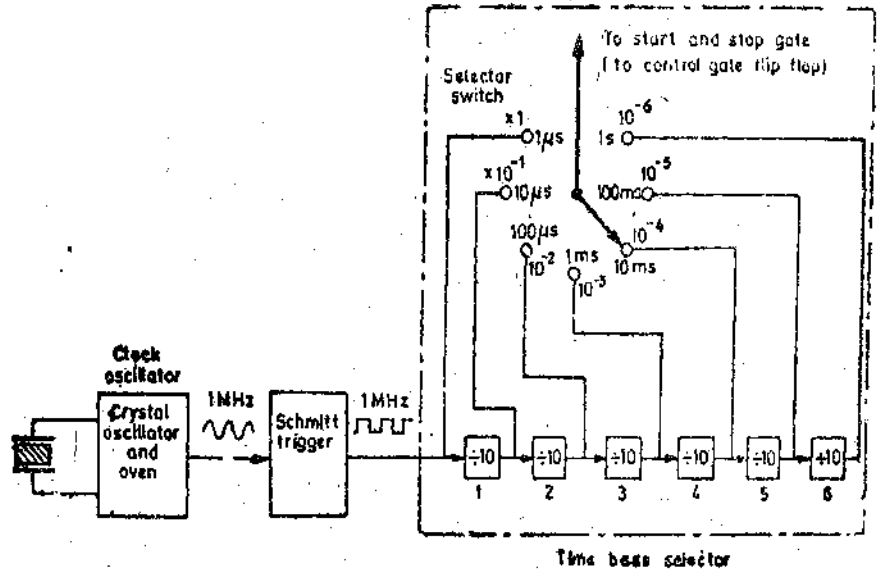

Fig: 28'34. Time base selector.

This time interval between the pulses is the time base and it can be selected by means of the selector switch.

28'23'4. Start and Stop Gate. The flip flops (FF) act as start and stop gates.

28'24. Circuit for Measurement of Frequency. The complete circuit for measurement of frequency is shown in Fig. 28'35. The positive pulses from the unknown frequency source called counted signal are arriving at input A of the main gate and positive pulses from time base selector are arriving at input B of the start gate and input B of stop gate. Initially, flip-flop FF₁ is its 1 state. The resulting voltage from output Y, applied to input A of stop gate opens this gate. The zero voltage from output Y of flip-flop FF₁, applied to input A of the start gate closes that gate.

As the stop gate is open, the positive pulses from the time base, can get through to set input terminal S of flip-flop FF₂ and keep it in state 1. The resulting zero output voltage from Y is applied to terminal B of main gate. Hence no pulses from the unknown frequency source can pass through the main gate.

In order to start the operation, a positive pulse, called read pulse is applied to reset terminal R of FF₁. This causes FF₁ to reverse its state from 1 to 0. Now its output \bar{Y} is positive voltage and output Y is 0. As a result, the stop gate is closed and start gate is opened. The same read pulse is applied to the decades of the counters bringing them to zero and thus the count can start now.

When the next pulse from the time base arrives it is able to pass through the start

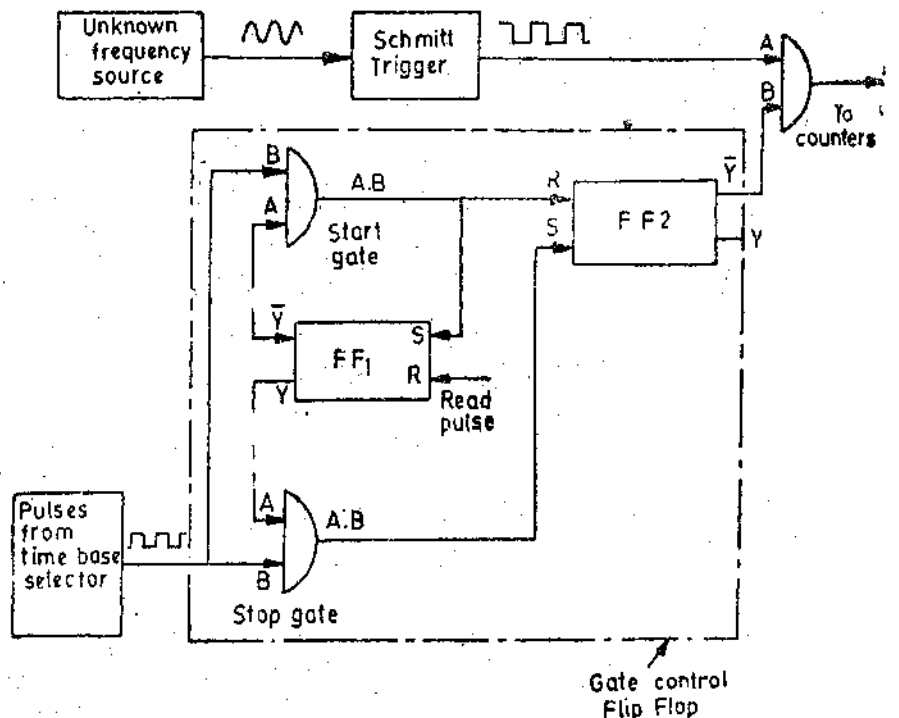

Fig. 28'35. Circuit for measurement of frequency.

gate to the reset terminal of FF₂ flipping it from its 1 state to 0 state. The resulting positive voltage from its input Y (called gating signal) is applied to input B of main gate opening that gate. Now the pulses from the unknown frequency source are able to pass through and they are registered on the counter. The same pulse that passes through the start gate is applied to the set input S of FF₁ changing its state from 0 to 1. This results in closing of start gate and the stop gate is opened. However, since the main gate is still open, pulses from the unknown frequency source continue to get through to the counter.

The next pulse from the time base selector passes through the open stop gate to the set input terminal S of FF₂ changing it back to its 1 state. Its output from terminal \bar{Y} becomes zero and so the main gate is closed and the counting stops

Thus the counter registers the number of pulses passing through the main gate in the time interval between two successive pulses from the time base selector. If for example, the time base selected is 1 second, the number indicated on the counters will be the frequency of the unknown frequency source in Hz.

The assembly consisting of the two AND gate and the two flip-flops is known as Gate Control Flip Flop.

28'25. **Simplified Composite Circuit of a Digital Frequency Meter.** A simplified composite circuit of a digital frequency meter is shown in Fig. 28'36. The principle of operation of the circuit is the same as described in Art. 28'24.

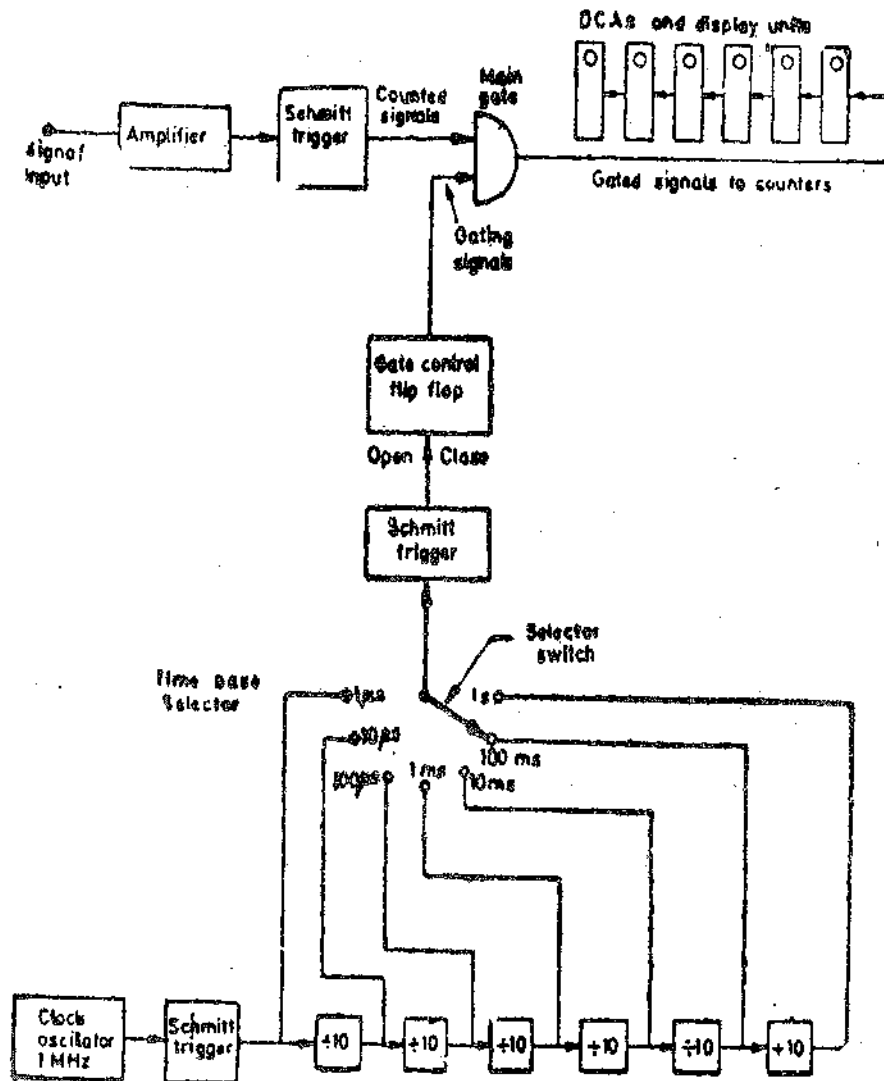

Fig. 28'36. Circuit of a digital frequency meter,

There are two signals to be traced :

- (i) *Input signal*—(or the counted signal). The frequency to be measured.
- (ii) *Gating signal*—This determines the length of time during which the counters (which consist of decade counter assemblies) are allowed to totalize the pulses.

The input signal is amplified and is applied to a Schmitt trigger where it is converted to a train of pulses.

The time base is shaped by a Schmitt trigger into positive pulses, $1 \mu\text{s}$ apart. These pulses are applied to 6 decade divider assemblies (DDAs). A selector switch allows the time interval to be selected from $1 \mu\text{s}$ to 1s . The input to the time base is provided by a clock oscillator and a Schmitt trigger.

The first output pulse from the time base selector switch passes through the Schmitt trigger to the gate control flip-flop. The gate control flip-flop assumes a state such that an enable signal is applied to the main gate. The main gate being an AND gate, the input signal pulses are allowed to enter the DCAs where they are totalized and displayed. This process continues till a second pulse arrives at the control gate flip-flop from the DDAs (Decade dividing assemblies). The control gate reverses its state which removes the enabling signal from the main gate and no more pulses are allowed to go to counting assemblies since the main gate closes. Thus the number of pulses which have passed during a specific time are counted and displayed on the DCAs. The frequency can be read directly in case the time base selector moves the decimal point in the display area.

28.26. High Frequency Measurements. The direct count range of digital frequency meters extends from d.c. to a few hundred MHz. The limitation is on account of the counters used in conjunction with the digital frequency meters. The counters can work upto a limited rate of counting and not beyond it and high frequency measurements demand a very high rate of counting.

This range (*i.e.*, a few hundred MHz) covers only a small portion of the frequency spectrum in use now-a-days. So techniques other than direct counting are used to extend the range of digital frequency meters to above 40 GHz. The frequency of the input signal is reduced before it is applied to a digital counter. This is done by special techniques. Some of the techniques in use are :

1. **Prescaling.** The high frequency signal is divided by some numbers—2, 4, 6, 8, etc. by using high speed divider circuits to get it within the frequency range of the digital frequency meter.

2. **Heterodyne Converter.** The high frequency signal is reduced in frequency to a range within that the meter by using heterodyne techniques.

3. **Transfer Oscillator.** A harmonic of a tunable low frequency continuous wave oscillator is zero beat with the unknown high frequency signal. The low frequency oscillator frequency is measured. This measured frequency is then multiplied by an integer which is equal to the ratio of the two frequencies in order to determine the value of the unknown high frequency.

4. **Automatic Divider.** The high frequency signal is reduced by some factor such as 100 : 1 or 1000 : 1 using automatically tuned circuits which generate an output frequency equal to $1/100$ or $1/1000$ of the input frequency to get it within the range of the digital frequency meter.

28.27. Period Measurement. Sometimes it is desirable and necessary to measure the period of an input signal rather than its frequency.

This is specially true when measuring the low frequencies because measurement of frequencies in the low frequency range using frequency mode of operation gives low accuracy. To get good accuracy at low frequencies, we should make measurement of period to know the unknown frequency rather than make direct frequency measurements. Now period of unknown frequency, $T=1/f$. Thus measurement of period can be done directly by interchanging the two input signals to the main gate.

The circuit for measurement of frequency shown in Fig. 28.36 can be used for measurement of time period but the counted signal and the gating signal are reversed. Fig. 28.37 shows the circuit for measurement of time period. The gating signal is derived from the unknown input signal which now controls the opening and closing of the main gate. In the diagram (Fig. 28.37) the time base is

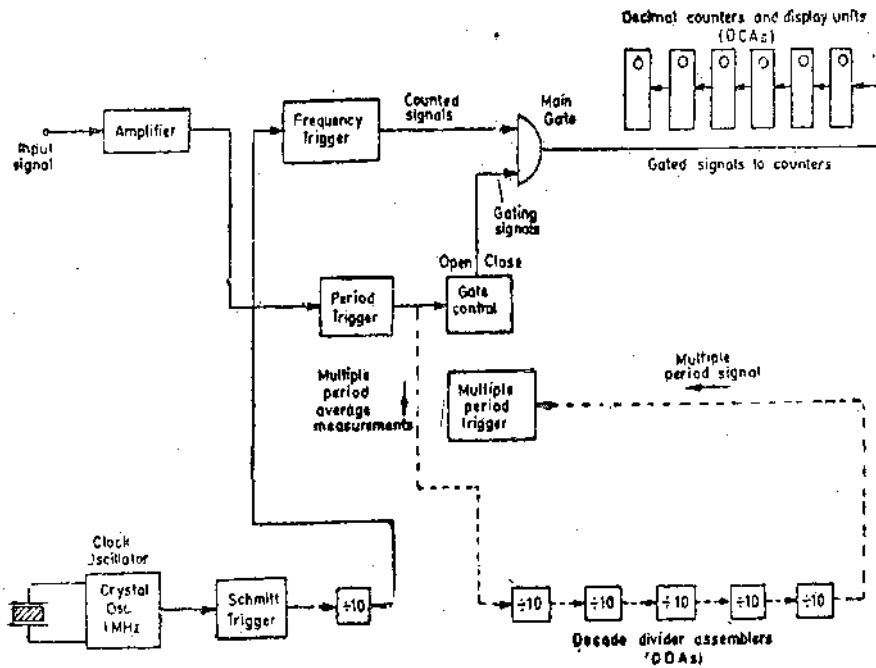

Fig. 28'37. Block diagram of single and multiple period (average) measurement.

set at $10 \mu s$ (frequency 0.1 MHz). The number of pulses which occur during one period of the unknown signal are counted and displayed by the decade counting assemblies.

The only drawback in using period measurements is that to get accuracy at low frequencies, the operator must take the reciprocal of the answer displayed by the display of the counters if he wants to know the input frequency.

For example when measuring the period of a 0 Hz frequency, the electronic counter might display 16.6673 ms .

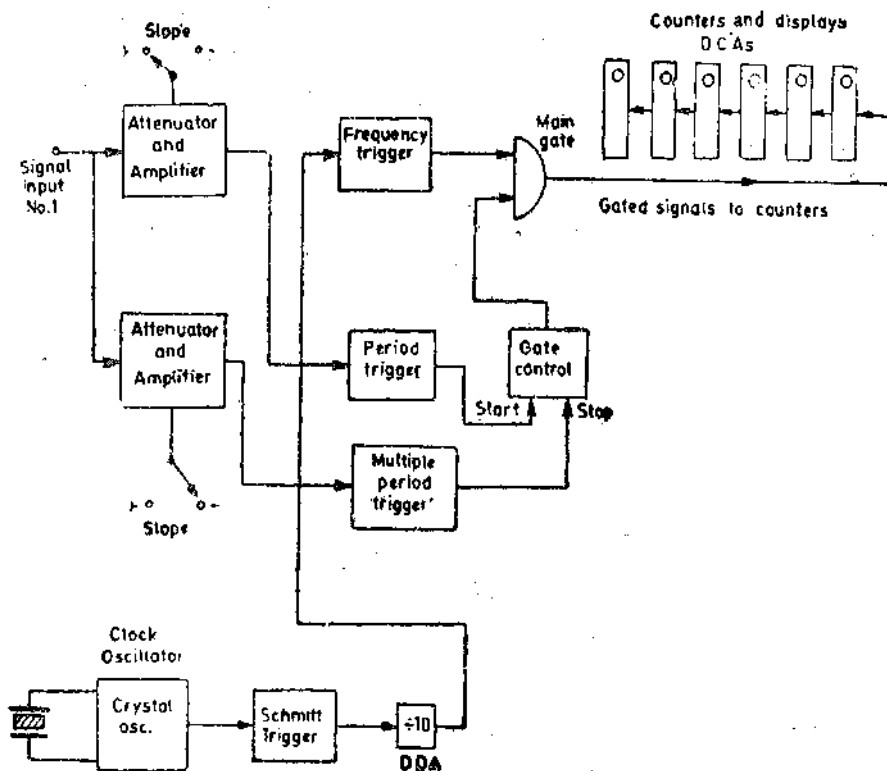

Fig. 28'38. Block diagram for time interval measurement.

$$\therefore \text{Frequency } f = \frac{1}{16.6673 \times 10^{-3}} = 59.9977 \text{ Hz.}$$

The accuracy of the period measurement and hence of frequency can be greatly increased by using the multiple period average mode of operation. In this mode, the main gate is held open for more than one period of the unknown signal.

This is done by passing the unknown signal through one or more decade divider assemblies (DDAs) so that the period is extended by a factor of 10, 100 or more.

Hence the digital display on the counters will show more digits of information thus increasing the accuracy. However, the decimal point location and measurement units are usually changed each time an additional decade divider is added so that the display is always in terms of the period of 1 cycle of the input signal, even though the measurement may have lasted for 10 or 100 or more cycles.

Fig. 28'37 shows the multiple period average mode of operation by the dashed portion of the block diagram. In this diagram 5 more decade dividing assemblies (DDAs) have been added so that the gate now remains open for an interval of 10^5 times than it did with that only one DDA.

28'28 Ratio and Multiple Ratio Measurements The ratio measurement involves the measurement of ratio of two frequencies. The measurement in effect is a period measurement. The lower frequency is used as a gating signal while the higher frequency is the counted signal. Thus the lower frequency takes the place of the time base. The block diagram for ratio and multiple ratio measurements is shown in Fig 28'39.

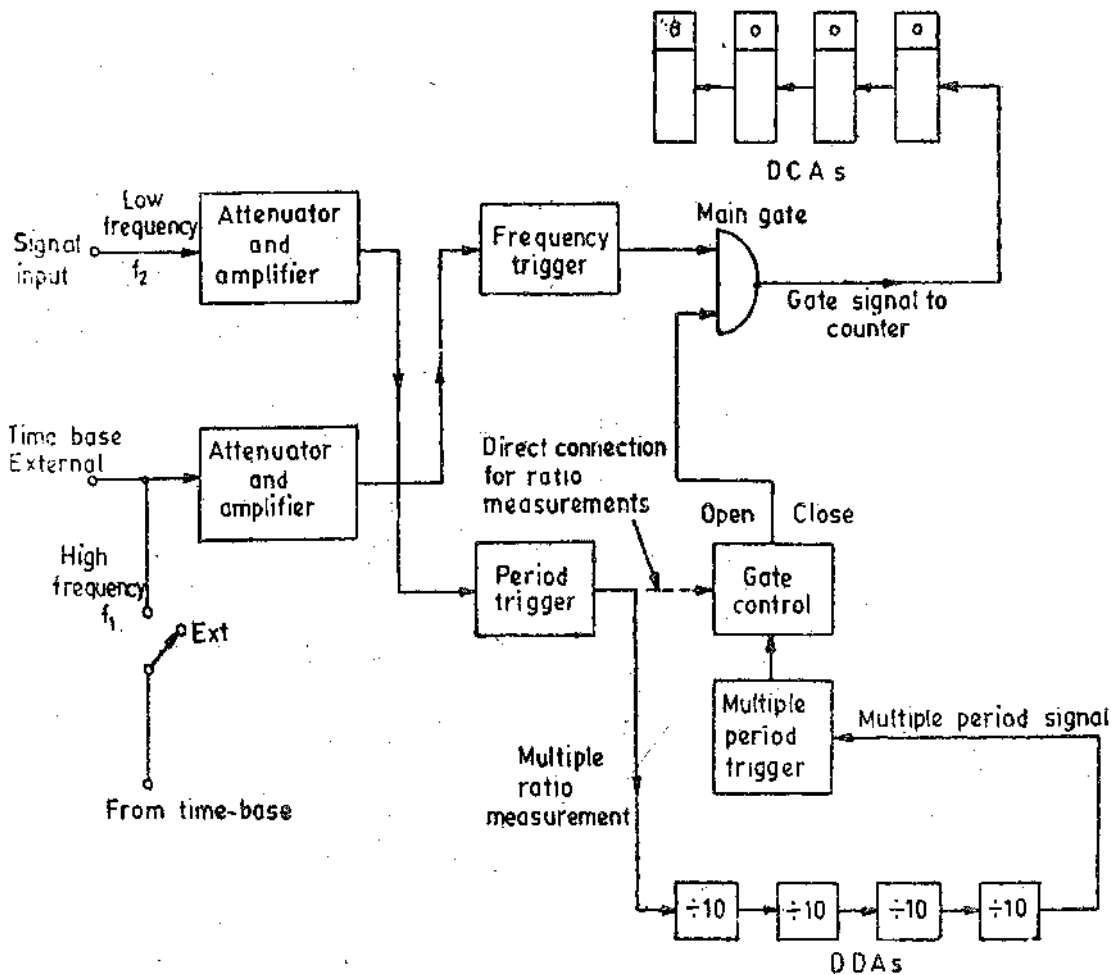

Fig. 28'39. Ratio and multiple ratio modes.

The number of cycles of the high frequency signal f_1 which occur during the period of lower frequency signal f_2 are counted and are displayed by DCAs.

In the multiple ratio measurements, the periods of the lower frequency signal is extended by a factor of 10,100, etc. by using DDAs.

28'29. Time Interval Measurement

In this measurement, the electronic counter used as an output readout device performs the function of an electronic stop watch i.e., it measures the time interval.

The block diagram for time interval measurement is shown in Fig. 28'38. There are input channels where one channel supplies the enabling pulse for the main gate and the other a disabling pulse.

The main gate is opened at a point on the leading edge of the input signal and closed on the trailing edge of the same signal. The time elapsed between the above two events is measured by the decade counter assemblies (DCAs). Since we are using a standard crystal oscillator, the counts displayed on the DCAs must be some multiple or submultiple of the frequency of the crystal oscillator. Thus the count displayed is in a way a yardstick to measure the time elapsed between opening and closing of the main gate.

Since the time interval during which the gate remains open and closed depends upon the waveshape of the input signal, the devices for measurement of time interval must have slope selection feature. The trigger level control permits selection of the input signal waveform at which the measurement begins and ends.

28 30 Universal Counter Timer. All the measurements described in the preceding sections. (connected frequency and time measurements) use almost identical fundamental building blockse These fundamental blocks may be assembled together to form modern Universal Counter Timer. Th universal counters use logic gates which are selected and controlled by a single front panel switch known as the "Function switch".

A simplified block diagram of a universal counter is shown in Fig. 28'40. With the function switch in the frequency mode (as shown in Fig. 28 40), a control voltage is applied to the specific gates of logic control circuitry. Thus the input signal is connected to the counted-signal channel of

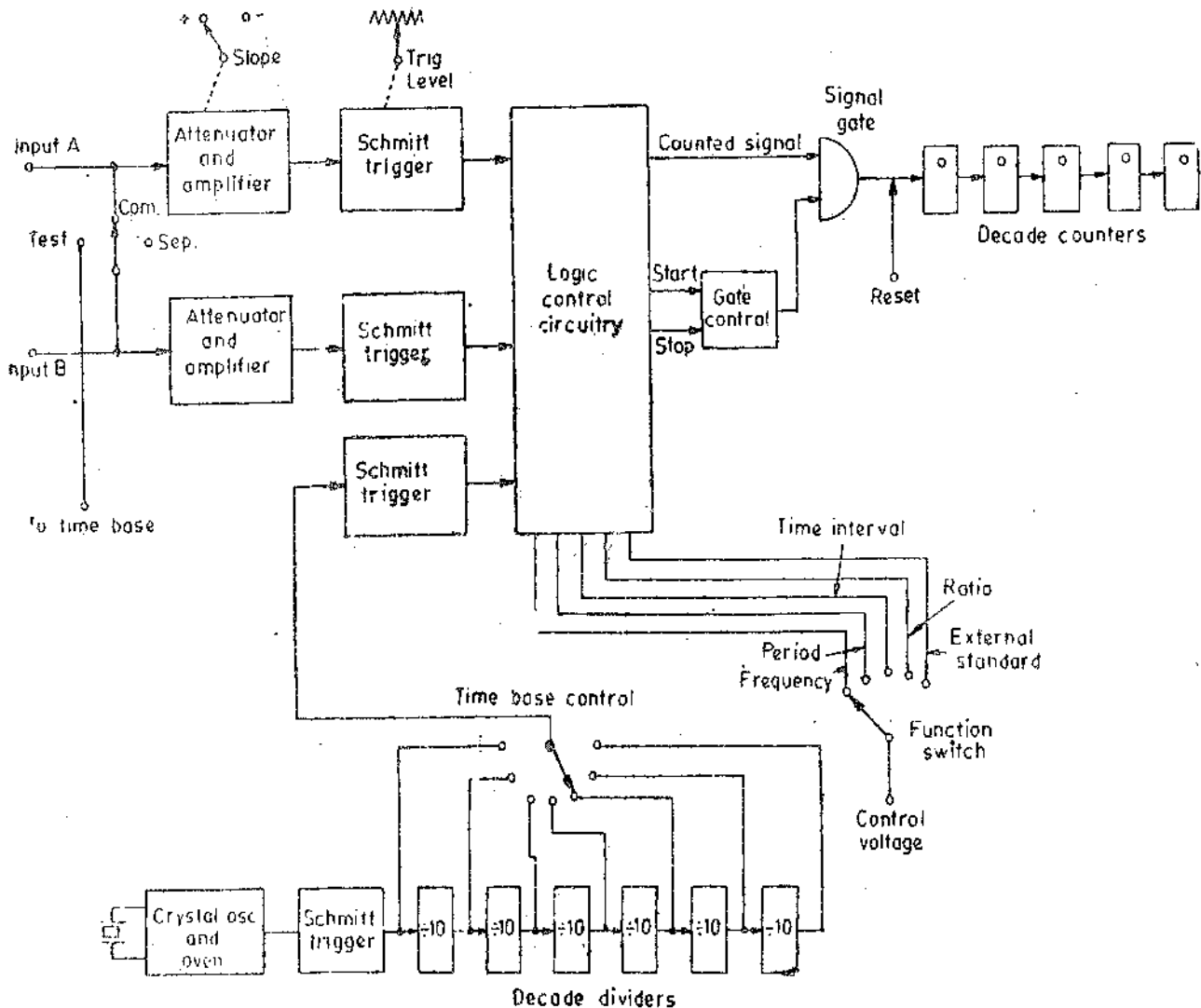

Fig. 28'40. Block diagram of a universal counter-time.

the main gate. The selected output from the time base dividers is simultaneously gated to the control flip-flop, which enables or disables the main gate. Both control paths are latched internally to allow them to operate only in the proper sequence.

When the function switch is in Period mode, the control voltage is connected to proper gates of logic circuitry, which connect the time base signal to the counted-signal channel of the main gate. At the same time the logic circuitry connects the input to the gate control for enabling or disabling the main gate. The other function switches (like time interval, ratio, external standard) perform similar functions. The exact details of switching and control procedures vary from instrument to instrument. They can be known by consulting the instrument catalogues.

Example 28.4. Gating periods of 1 ms, 10 ms, 100 ms, 1 s, and 10 s are provided on a digital counter-time-frequency meter having a 3 digit display. A gating period of 10 ms is selected to measure an unknown frequency and a reading of 034 is obtained. What is the likely value of frequency? What steps be taken (a) to check the validity of the result; (b) to obtain a more accurate result?

Solution.

$$(a) \text{ Frequency } f = \frac{N}{t} = \frac{0.34}{10 \times 10^{-3}} = 3400 \text{ Hz} = 3.4 \text{ kHz.}$$

(b) In order to check the validity of the result, we should use a lower gating time *i.e.*, 1 ms. In case the frequency is between 3000 to 3499 Hz, the readings will be:

$$3000 \times 1 \times 10^{-3} = 3 \text{ and } 3499 \times 1 \times 10^{-3} = 3.499$$

Since the meter has a 3 digit display it can show the readings as 0 0 3 in both the cases.

(c) In order to get better results (better resolution) we must use a higher gating time *i.e.*, 100 ms.

Suppose the frequency is 3420 Hz instead of 3400 Hz. The reading of the meter will be: $3420 \times 100 \times 10^{-3} = 342$.

No useful purpose will be served if the gating time is increased to 1 s or 10 s. Suppose the frequency is 3424 Hz and the gating time is kept as 1s. The reading is $3425 \times 1 = 3424$

But since the meter has only 3 digits, the meter will show an overflow. Same is the case for the gating time of 10 s.

Example 28.5. A digital timer with eight digit readout is stated to have an accuracy of 0.005 percent of reading, ± 1 in the final digit. Readout is in s, ms, and μ s. Assuming that the instrument meets its specifications, what are the maximum likely errors when the reading is:

(a) 05 00 0000 μ s (b) 00 000 500 s?

(c) What is the maximum nominal accuracy in time units with which reading (b) could be made with this instrument?

Solution.

(a) The reading is 05 000 000 μ s or Reading = 5000 000 μ s = $5 \times 10^6 \mu$ s

$$0.005 \text{ percent of reading} = \pm \frac{0.005}{100} \times 5 \times 10^6 = \pm 250 \mu$$

The digit in LSD has a value of 1 μ s. \therefore Maximum error = $\pm 250 \pm 1 = \pm 251 \mu$ s.

(b) The reading is 00 000 500 s or Reading = 500 s.

$$0.005 \text{ percent of reading} = \pm \frac{0.005}{100} \times 500 = \pm 0.025 \text{ s.}$$

The digit in LSD has now a value of 1 s. \therefore Maximum error = $\pm 0.025 \pm 1 = \pm 1.025 \text{ s.}$

(c) Maximum accuracy means minimum error.

Minimum error is obtained when the time is read on the μ s read out.

$$500 \text{ s} = 500 \times 10^6 \mu\text{s} = 500\,000\,000 \mu\text{s.}$$

This read out requires 9 digit positions and hence when the meter is put on the μ s readout will show an overflow as the meter has 8 digit display. Hence a reading of 500 s cannot be taken the μ s range.

Let us try the ms readout. $500 \text{ s} = 500 \times 10^3 \text{ ms} = 500\,000 \text{ ms}$.

\therefore The ms readout will display the reading as 00500 000

$$0.005 \text{ percent of reading} = \pm \frac{0.005 \times 500 \times 10^3}{100} = \pm 25 \text{ ms.}$$

The LSD has a value of 1 ms.

\therefore Maximum possible accuracy with which a reading of 500 s can be read by this meter is $\pm 25 \pm 1 = \pm 26 \text{ ms}$.

DIGITAL VOLTMETERS (DVMs)

28.31. Introduction

A digital voltmeter (DVM) displays the value of a c. or d.c. voltages being measured directly as discrete numerals in the decimal number system. Numerical readout of DVMs is advantageous since it eliminates observational errors committed by operators. The errors on account of parallax and approximations are entirely eliminated. The use of digital voltmeters increases the speed with which readings can be taken. Also the output of digital voltmeters can be fed to memory devices for storage and future computations.

A digital voltmeter is a versatile and accurate voltmeter which has many laboratory applications. On account of developments in the integrated circuit (IC) technology, it has been possible to reduce the size, power requirements, and cost of digital voltmeters. In fact, for the same accuracy, a digital voltmeter now is less costly than its analog counterpart. The decrease in size of DVMs on account of use of ICs, the portability of the instruments has increased.

28.32. Types of DVMs The increasing popularity of DVMs has brought forth a wide number of types employing different circuits. The various types of DVMs in general use are :

- (i) Ramp type DVM,
- (ii) Integrating type DVM,
- (iii) Potentiometric type DVM,
- (iv) Successive approximation type DVM,
- and (v) Continuous balance type DVM.

The circuits described here do not represent those of any specific make of a digital voltmeter. These circuits are being described merely to explain the voltage measuring principles on which these instruments operate.

In every case, the basic function that is performed, is an analog to digital (A/D) conversion. For example, a voltage value may be changed to a proportional time interval, which starts and stops a clock oscillator. In turn the oscillator output is applied to an electronic counter which is provided with a readout in terms of voltage values. The A/D conversion techniques have already been explained in Art. 26.33 page 884.

28.33 Ramp type Digital Voltmeter. The operating principle of a ramp type digital voltmeter is to measure the time that a linear ramp voltage takes to change from level of input voltage to zero voltage (or *vice versa*). This time interval is measured with an electronic time interval counter and the count is displayed as a number of digits on electronic indicating tubes of the output readout of the voltmeter.

The conversion of a voltage value to a time interval is shown in the timing diagram of Fig. 28.41.

At the start of measurement a ramp voltage is initiated. A negative going ramp is shown in Fig. 28.41 but a positive going ramp may also be used. The ramp voltage value is continuously compared with the voltage being measured (unknown voltage). At the instant the value of ramp voltage is equal to that of unknown voltage a coincidence circuit, called an input comparator, generates a pulse which opens a gate (See Fig. 28.42). The ramp voltage continues to decrease till it reaches ground level (zero voltage). At this instant another comparator called ground comparator generates a pulse and closes the gate.

The time elapsed between opening and closing of the gate is t as indicated in Fig. 28.41. During this time interval pulses from a clock pulse generator pass through the gate and are counted and displayed.

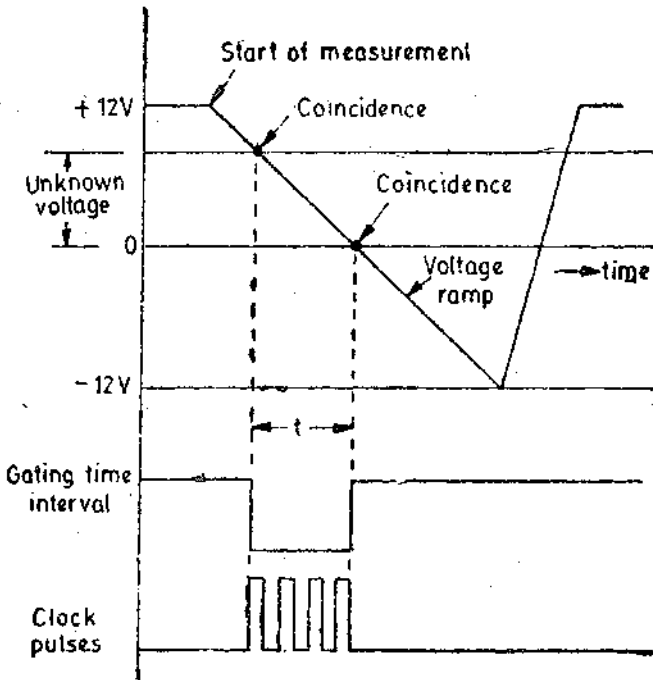

Fig. 28-41. Timing diagram showing voltage to time conversion.

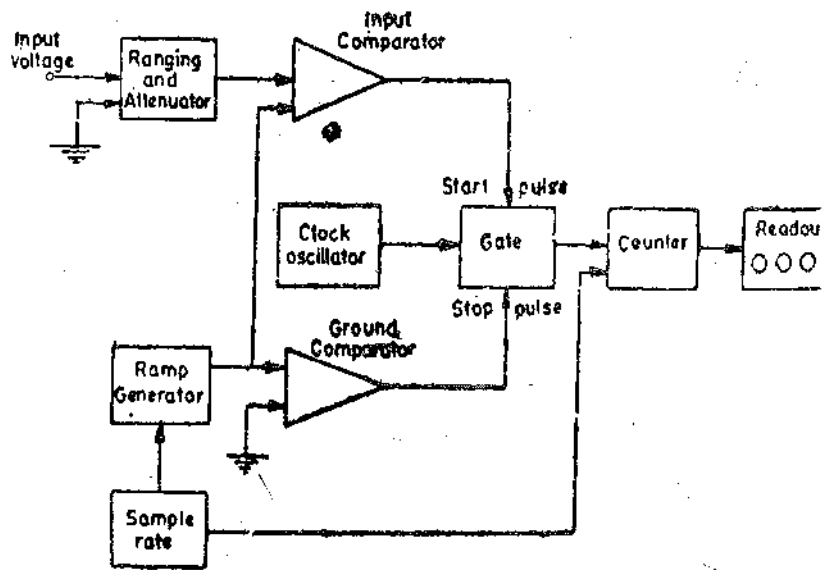

Fig. 28-42. Block diagram of a ramp DVM.

The decimal number as indicated by the readout is a measure of the value of input voltage.

The sample rate multivibrator determines the rate at which the measurement cycles are initiated. The sample rate circuit provides an initiating pulse for the ramp generator to start its next ramp voltage. At the same time it sends a pulse to the counters which sets all of them to 0. This momentarily removes the digital display of the readout.

28-34. Integrating Type Digital Voltmeter. This voltmeter measures the true average value of the input voltage over a fixed measuring period. In contrast the ramp type DVM samples the voltage at the end of the measuring period. This voltmeter employs an integration technique which uses a voltage to frequency conversion. The voltage to frequency (V/F) converter functions as a feedback control system which governs the rate of pulse generation in proportion to the magnitude of input voltage.

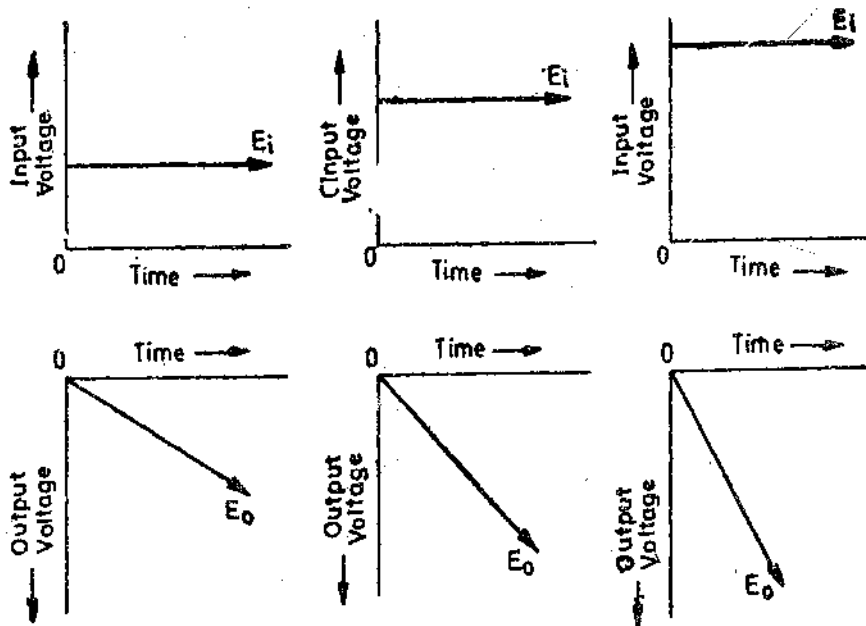

Fig. 28-43. Graphs showing slopes and magnitudes of output voltages for various input voltages.

Actually when we employ the voltage to frequency conversion technique, a train of pulses, whose frequency depends upon the voltage being measured, is generated. Then the number of pulses appearing in a definite interval of time is counted. Since the frequency of these pulses is a function of unknown voltage, the number of pulses counted in that period of time is an indication of the input (unknown) voltage.

The heart of this technique is the operational amplifier acting as an Integrator.

$$\text{Output voltage of integrator } E_0 = -E_i \frac{1}{RC} t$$

Thus if a constant input voltage E_i is applied, an output voltage E_0 is produced which rises at a uniform rate and has a polarity opposite to that input voltage. In other words, it is clear from the above relationship, that for a constant input voltage the integrator produces a ramp output voltage of opposite polarity.

Let us examine Fig. 28'43. Here the graphs showing relationships between input voltages of three different values and their respective output voltages are shown. It is clear that the polarity of the output voltage is opposite to that of input voltage. Not only that, the greater the input voltage, the sharper is the rate of rise, or slope, of output voltage.

The basic block diagram of a typical integrating type of DVM is shown in Fig. 28'44. The unknown voltage (E_i) is applied to the input of the integrator, and the output voltage (E_0) starts to rise. The slope of output voltage (E_0) is determined by the value of input voltage (E_i). This voltage is fed to a level detector, and when E_0 reaches a certain reference level, the detector sends a pulse to the pulse generator gate.

The level detector is a device similar to a voltage comparator. The output voltage from integrator (E_0) is compared with the fixed voltage of an internal reference source, and, when E_0 reaches that level, the detector produces an output pulse. It is evident that greater the value of input voltage E_i , the sharper will be the slope of output voltage E_0 , and quicker the output voltage E_0 will reach its reference level.

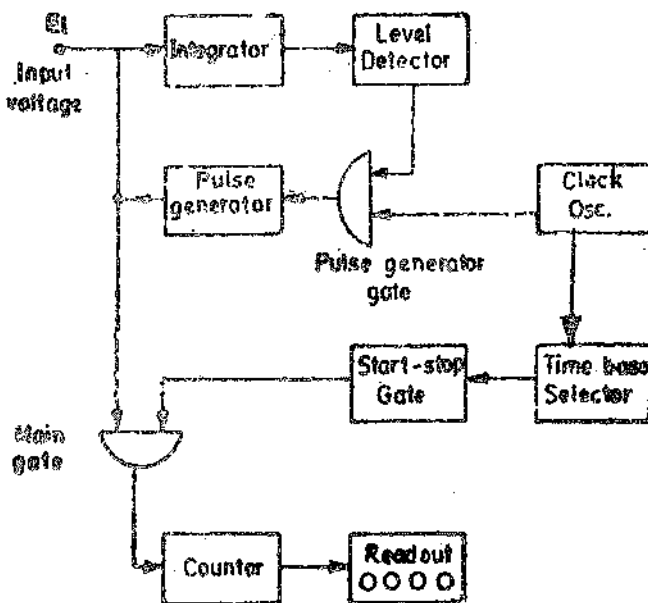

Fig. 28'44. Block diagram of integrating type DVM.

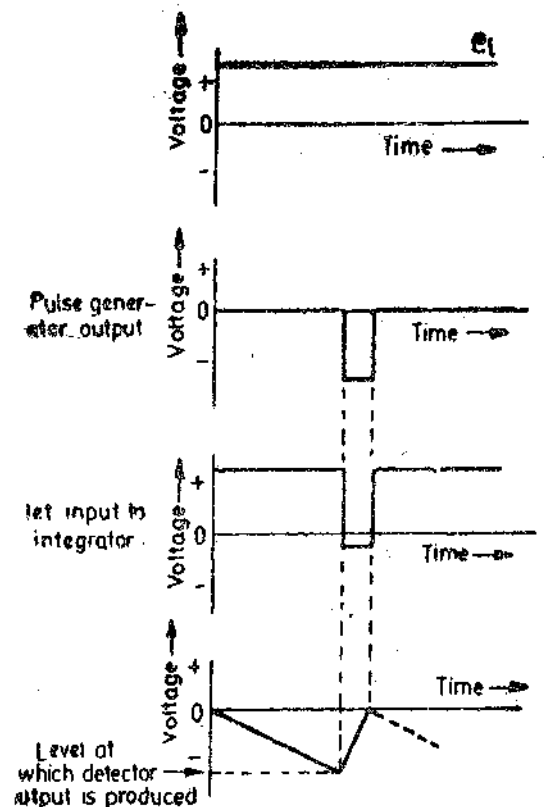

Fig. 28'45. Waveform of output voltage.

The output pulse of the level detector opens the pulse level gate, permitting pulses from a fixed frequency clock oscillator to pass through pulse generator. The generator is a device such as a Schmitt trigger, that produce an output pulse of fixed amplitude and width for every pulse it receives.

This output pulse, whose polarity is opposite to that of E_i and has a greater amplitude, is fed back of the input of the integrator. Hence, the net input to the integrator is now of a reversed polarity (opposite to that of E_i as is clear from Fig. 28'45). As a result of this reversed input, the output E_0 drops back to its original level. Since E_0 is now below the reference level detector, there is no output from the detector to the pulse generator gate and the gate gets closed. Thus no more pulses from the clock oscillator can pass through to trigger the pulse generator.

When the output voltage pulse from the pulse generator has passed, E_i is restored to its original value and E_0 starts its rise again. When it reaches the level of reference voltage again, the pulse generator gate is opened. The pulse generator is triggered by a pulse from the clock generator, and the entire cycle is repeated again. Thus, the waveform of E_0 is a sawtooth wave whose rise time is dependent upon the value of output voltage E_i and the fall time is determined by the width of the output pulse from the pulse generator.

Thus the frequency of the sawtooth wave (E_0) is a function of the value of E_i , the voltage being measured. Since one pulse from the pulse generator is produced for each cycle of the sawtooth wave, the number of pulses produced in a given time interval and hence the frequency of sawtooth wave is an indication of the value of voltage being measured.

The frequency of sawtooth wave may be measured by counting the number of pulses in a given interval of time.

Pulses from the clock oscillator are applied to a time base selector. The first pulse passes through start-stop gate, producing an output which is applied to the main gate, thus opening the gate. As a result of this, the same output pulses from the pulse generator (that are applied to integrator) also pass through the main gate.

The next pulse from the time base closes the start-stop gate and also the main gate. Thus no more pulse generator pulses can pass through. Hence the counters and their associated readout indicate the number of pulses that have passed during a known interval of time. This count is an indication of the voltage being measured. In order to make the counter read directly in terms of voltage, the amplitude and width of pulse generator pulses can be suitably adjusted.

28'35. Potentiometric Type Digital Voltmeter. A potentiometric type of DVM employs voltage comparison technique. In this DVM the unknown voltage is compared with a reference voltage whose value is fixed by the setting of the calibrated potentiometer. The potentiometer setting is changed to obtain balance (*i.e.* null conditions). When null conditions are obtained the value of the unknown voltage, is indicated by the dial setting of the potentiometer.

In potentiometric type DVMs, the balance is not obtained manually but is arrived at automatically. Thus, this DVM is in fact a self-balancing potentiometer as explained in Art. 1'14 on page 468. The only exception is that a potentiometric DVM is provided with a readout which displays the voltage being measured.

The block diagram of basic circuit of a potentiometric DVM is shown in Fig. 28'46. The unknown voltage is filtered and attenuated to suitable level. This input voltage is applied to a comparator (also known as error detector). This error detector may be chopper. The function of a chopper is explained on page 469. The reference voltage is obtained from a fixed voltage source. This voltage is applied

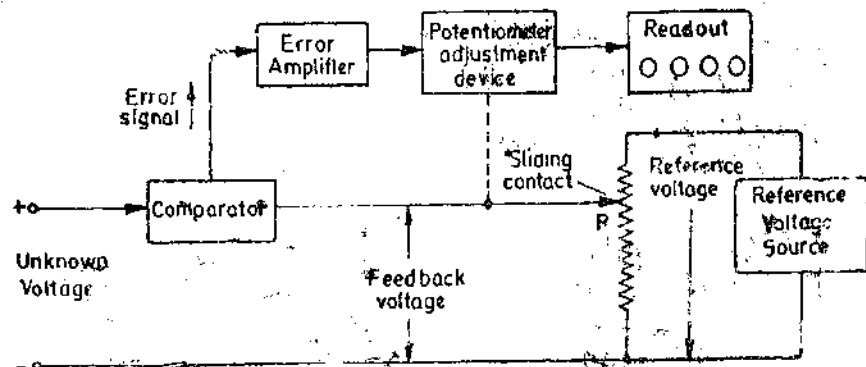
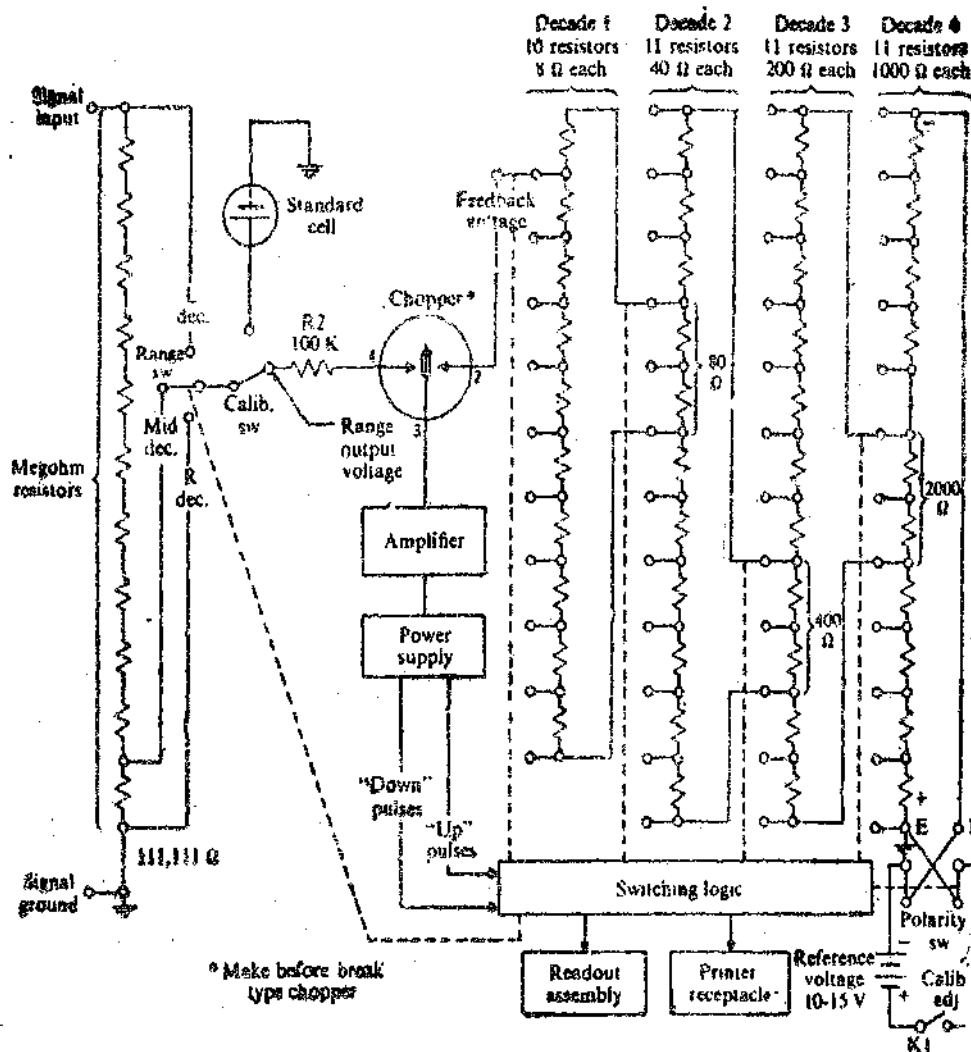

Fig. 28'46 Basic block diagram of a potentiometric DVM.

to a potentiometer R . The value of the feedback voltage depends upon the position of the sliding contact. The feedback voltage is also applied to the comparator.

The unknown voltage and the feedback voltages are compared in the comparator. The output voltage of the comparator is the difference of the above two voltages. The difference of voltage is called the error signal. The error signal is amplified and is fed to a potentiometer adjustment device which moves the sliding contact of the potentiometer. This magnitude by which the sliding contact moves depends upon the magnitude of the error signal. The direction of movement of slider depends upon whether the feedback voltage is larger or the input voltage is larger. The sliding contact moves to such a place where the feedback voltage equals the unknown voltage. In that case, there will not be any error voltage and hence there will be no input to the device adjusting the position of the sliding contact and therefore it (sliding contact) will come to rest.



2847. Practical potentiometric type digital voltmeter circuit.

The position of the potentiometer adjustment device at this point is indicated in numerical form on the digital readout device associated with it. Since the position at which no voltage appears at potentiometer adjustment device is the one where the unknown voltage equals the feedback voltage, the reading of readout device indicates the value of unknown voltage.

The potentiometer adjustment device i.e., the device which moves the sliding contact is a 2 phase servomotor. The automatic action of adjustment of sliding contact with the help of a servomotor has already been explained on page 469.

The reference voltage source must be extremely stable and generally consists of a standard cell or a Zener diode sources.

Practical Potentiometric DVM. A practical potentiometric DVM does not consist of a single resistor R but consists of a number of decade resistors connected in the Kelvin Varley slide fashion.

Fig. 28 47 shows a practical potentiometric DVM circuit. A stepping switch operates the variable voltage divider, which is composed of wire wound resistors and divides the reference voltage into a number of precisely equal parts in a decimal number system. This circuit has four resistance decades and therefore converts the input (unknown) analog voltage to a 4-digit decimal number. There are four stepping switches (which may be called decade switches). An error amplifier compares the feed back voltage with the input signal and commands stepping switches to move until they come to a position where the two voltages are within the limits of resolution of the instrument. At this point the stepping switch motion stops and the readout indicates the value of the input (unknown) voltage.

28 36. Other Types of Measurements with a DVM. The digital voltmeter is essentially, a d.c. voltmeter. If a.c. voltages are to be measured, they are first converted to equivalent d.c. voltages, which are then measured by the digital voltmeter. This is done by an a.c to d.c. converter.

If current is to be measured, it is passed through a standard resistor. The voltage appearing across the resistor is then measured with a DVM. The value of current can thus be known from the counts appearing on the counters of the readout system of DVM.

Similarly a resistance is to be measured, a fixed current is first passed through a resistor. The voltage drop, across the resistor, which is proportional to the resistance is measured by the DVM. The number of counts appearing on the counters is a measure of the resistance.

Other physical quantities may also be measured with DVMs by using suitable transducers to feed the input of the DVM.

RECORDERS

28 37. Necessity of Recorders. It is often necessary to have a permanent record of the state of a phenomenon being investigated. In many of the industrial and research processes it is necessary to monitor continuously the condition, state, or value of the process variables such as flow, force, pressure, temperature, current, voltage, electrical power etc. A recorder thus records electrical and non-electrical quantities as a function of time. This record may be written or printed, and later on, can be examined and analyzed to obtain a better understanding and control of the processes. Currents and voltages can be recorded directly while the non-electrical quantities are recorded indirectly by first converting them to equivalent currents or voltages with the help of sensors or transducers.

The ever increasing emphasis on automation, continuously recording instruments are finding many applications in industry

28 38. Recording Requirements. One of the important consideration in an instrumentation system is the method by which the data acquired is recorded. The recording method should be consistent with the type of system. If we are dealing with a wholly analog system, then **analog recording techniques** should be used. While on the other hand, if the system has a digital output, **digital recording devices** are used.

Thus there are two types of recording devices :

(i) Analog recorders, and (ii) Digital recorders.

28 39. Analog Recorders. There are numerous types of analog recorders. They can be broadly classified into :

(i) Graphic recorders. (ii) Oscillographic recorders (iii) Magnetic tape recorders.

28 40. Graphic Recorders. Graphic recorders generally are devices which display and store a pen-and-ink record of the history of some physical event.

Basic elements of a recorder include a chart for displaying and storing the recorded information, a stylus moving in a proper relationship to the paper, and suitable means of interconnection to couple the stylus to the source of information.

For the purposes of this book, we classify the graphic recorders into two categories.

(i) **Strip chart recorders.** A strip chart recorder records one or more variables with respect to time. It is an X-t recorder.

(ii) **X-Y recorders.** An X-Y recorder records one or more dependent variables with respect to an independent variable.

28.41. Strip Chart Recorders. Fig. 28.48 shows basic constructional features of a strip chart recorder.

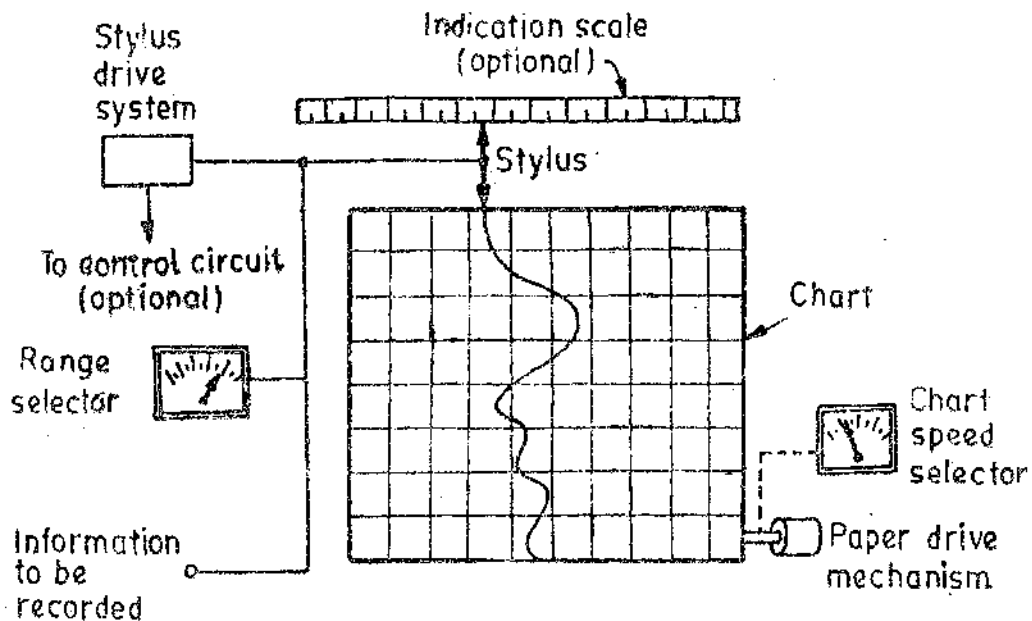

Fig. 28.48. Strip chart recorder.

A strip chart recorder consists of :

- (i) A long roll of graph paper moving vertically.
- (ii) A system for driving the paper at some selected speed. A speed selector switch is generally provided. Chart speeds of 1–100 mm/s are usually used.
- (iii) A stylus for making marks on the moving graph paper. The stylus moves horizontally in proportional to the quantity being recorded.
- (iv) A stylus driving system which moves the stylus in a nearly exact replica or analog of the quantity being recorded.

A range selector switch is used so that input to the recorder drive system is within the acceptable level.

Most recorders use a pointer attached to the stylus. This pointer moves over a calibrated scale thus showing the instantaneous value of the quantity being recorded. An external control circuit for the stylus may be used.

A. Paper Drive Systems. The paper drive system should move the paper at a uniform speed. A spring wound mechanism may be used but in most of the recorders a synchronous motor is used for driving the paper.

B. Marking Mechanisms. There are many types of mechanisms used for making marks on the paper. The most commonly used ones are :

1. Marking with Ink filled Stylus. The stylus is filled with ink by gravity or capillary actions. This requires that the pointer shall support an ink reservoir and a pen, or contain a capillary connection between the pen and a pen reservoir as shown in Fig. 28.49. In general red ink is used but other colours are available and in instrumentation display a colour code can be adopted. The stylus, moving over the paper with preprinted scales, traces the variations of the input signal,

This method is most commonly employed as ordinary paper can be used and therefore the cost is low. Other advantages are that with this system, operation over a very wide range of recording speeds is possible and also there is little friction between the stylus tip and the paper. The disadvantages of this method are that ink splatters at high speeds, batches at low speeds and clogs when the stylus is at rest. The frequency limit of recorders incorporating this method of writing is only a few Hz.

2. Marking with Heated Stylus. Some recorders use a heated stylus which writes on a special paper. This method overcomes the difficulties encountered in ink writing systems.

The heated stylus melts a thin, white wax like coating on a black paper base. Since the paper required is a special one, the cost is high. This method cannot be used for recording certain processes which produce heat which indirectly effect the recordings. But this method is quite reliable and offers high-contrast traces. Sophisticated recorders using papers with waxed surfaces and special pens, have a frequency response upto 40 Hz are available.

3. Chopper Bar. If a chart made from a pressure sensitive paper is used a simple recording process is possible. A V-shaped pointer is passed under a chopper bar which presses the pen into the paper once per second (or any other selected interval) thus making a series of marks on the special paper. In fact this system is not purely continuous and hence is suitable for recording some slowly varying quantities, for example those which have a variation of 1 cycle per hour. This type of marking has the advantage of a straight line horizontal scale without the use of complex linkage arrangement.

4. Electric Stylus Marking. This method employs a paper with a special coating which is sensitive to current. When current is conducted from the stylus to the paper, a trace appears on the paper. It is clear that the electric stylus marking method has a wide range of marking speeds, has low stylus friction and a long stylus life. The disadvantage is that the cost of paper is very high.

5. Electrostatic Stylus. This method uses a stylus which produces a high voltage discharge thereby producing a permanent trace on an electrosensitive paper. This arrangement has been incorporated in a recorder having a 50 mm wide chart nine voltage ranges from 10 mV/mm to 5 V/mm; eight chart speeds from 300 mm/s to 10 mm/min and a frequency response of 60 Hz at maximum amplitude of 1 db.

6. Optical Marking Method. This method uses a beam of light to write on a photosensitive paper. Thus this method allows higher frequencies to be recorded and permits a relatively large chart speed with good resolution. The disadvantages are that the paper cost is very high. Secondly the writing process is a photographic one, the paper must be developed before a record is available and hence this method is not suitable for processes where instantaneous monitoring is to be done.

C. Tracing Systems. There are two types of tracing systems used for producing graphic representations.

1. Curvilinear System. In the curvilinear system, the stylus is mounted on a central pivot and moves through an arc which allows a full-width chart marking. If the stylus makes a full range recording, the line drawn across the chart will be curved and the time intervals will be along this curved segments. This type of system is used on many records, with PMMC galvanometers actuating the stylus filled with ink as shown in Fig. 28'50. The disadvantage of this method of tracing is the charts are difficult to analyze because of curved time base lines.

2. Rectilinear System. Fig. 28'51 shows the rectilinear system of tracing. It is noticed that a line of constant time is perpendicular to the time axis and therefore this system produces a straight line across the width of the chart. Here the stylus is actuated by a drive cord over pulleys to produce the forward and reverse motion as determined by the drive mechanism. The stylus may be actuated by a self-balancing potentiometer system, a photoelectric deflection system, a photoelectric potentiometer system, or a bridge balance system. This system is usually used with thermal or electric writing.

28'42. Types of Strip Chart Recorders

1. Galvanometer Type. This type of strip chart recorder operates on the deflection principle.

The deflection is produced by a galvanometer which produces a torque on account of a current passing through its coil. This current is proportional to the quantity being measured.

2. **Null Type.** This type of recorder operates on comparison basis.

28'43. **Galvanometer Type Recorders.** These recorders use a d'Arsonval galvanometer described in Chapter 7. The pointer is equipped with a recording pen mechanism (stylus). A cut-away view of the moving coil element is shown in Fig. 28'49. As the current flows through the coil, it deflects. The greater the amplitude of the incoming signal (which is proportional to the quantity being measured), the greater is the deflection. When the pointer comes to rest on account of controlling torque exerted by springs, the stylus also comes to rest. Thus, the value of the quantity is recorded. The design of the d'Arsonval galvanometer used in recorders is different from the one described in Chapter 7. This is necessitated by the fact that in recorders, the movement of the instrument requires an appreciable torque. To obtain this torque the d'Arsonval movement consists of a large moving coil situated in a strong magnetic field.

It should be understood that the instrument must be critically damped or nearly critically damped so that there is no significant overshoot. But this results in slow response, the response time being 0'75 to 1'5 s.

Thus this type of recorder is not useful for recording fast variations in either current or voltage or power. This records only the average values and hence it should be designed for these. A galvanometer type recorder is shown in Fig. 28'49. It is a modified version of the PMMC instrument. The modification is done in order that the chart may be driven at a constant speed by a clockwork mechanism or an electric motor. The type of chart used depends upon the form of movement. The recorder shown in Fig. 29'49 uses a chart having a curvilinear system of tracing. This system is used because it allows the direct use of simple moving coil movement. However, some instruments employ additional linkage system in the system which allow the use of rectilinear system of tracing as shown in Fig. 28'50.

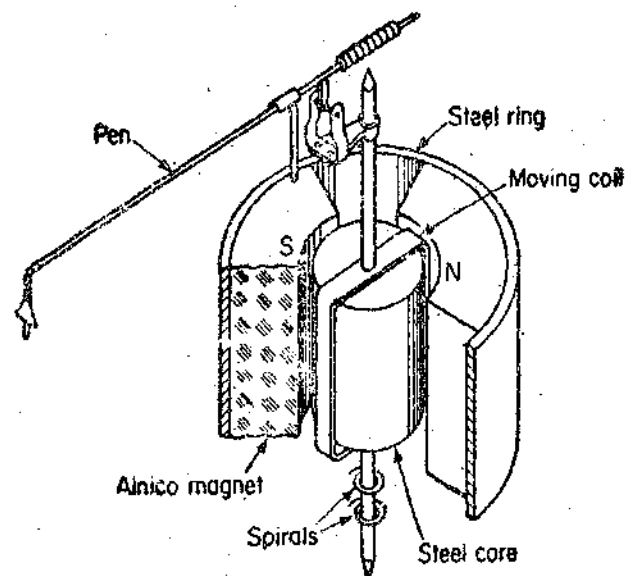

Fig. 28'49. Cut-away view of moving coil element.

The recorders can work on ranges from a few mA to several mA or from a few mV to several mV.

These moving galvanometer type recorder is comparatively inexpensive instrument having a narrow bandwidth of 0 to 10 Hz. It has a sensitivity of 0'4 mV/mm or from a chart of 100 mm width a full scale deflection of 40 mV is obtained. For measurement of smaller voltages linear amplifiers are used.

In these recorders the bearings must be substantially larger than those used in indicator instruments, because of the large mass of coil and stylus. On account of large mass of the moving mechanism, friction becomes a factor which cannot be ignored.

The analysis of the galvanometer movement in chapter 7 neglected the sliding friction which is also called **Coulomb Friction**. This friction is constant and when we consider it, the equation of motion of coil becomes :

$$J \frac{d^2\theta}{dt^2} + D \frac{d\theta}{dt} + K\theta + F = Gi \quad \dots(28'3)$$

where F = torque due to Coulomb friction, N-m.

Note that Eqn. 28'3 is a modified form of Eqn. 7'10 given on page 142.

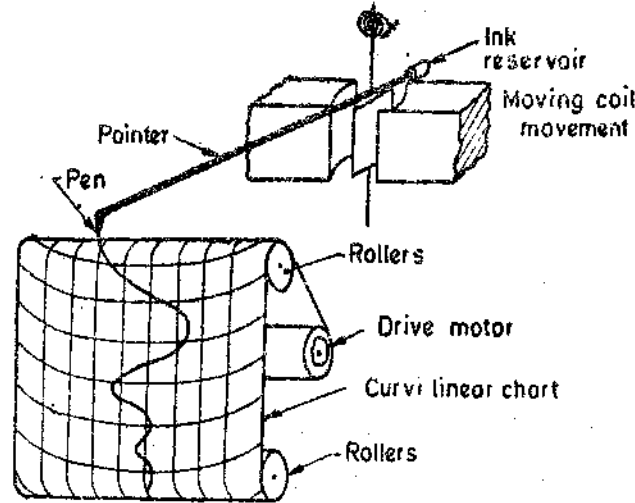

Fig. 28'50. Components of a galvanometer type recorder.

The solution of Eqn. 28'3, under steady state condition is :

$$K\theta + F = Gi \quad \text{or } \theta = \frac{Gi}{K} - \frac{F}{K} \quad \dots(28'4)$$

Therefore, the deflection of the stylus is proportional to the product of constant G/K and the current i , less a constant F/K . The term F/K is the error term which produces a dead zone (see Art. 2'23 page 22). Therefore care must be taken to reduce coulomb friction to a minimum and to produce a large driving torque so that F/K is very small as compared to Gi/K . Since $G = NBld$ (See Eqn. 7'4, page 141) therefore a large coil with many turns produces a large value of G resulting in large deflecting torque. (The deflecting torque being Gi). Also by increasing the flux density, B , the value of G can be increased. The value of flux density can be increased by reducing the air gap. These recorders give an accuracy of 2 percent or even better.

Example 28'6. The coil of a recording ammeter is 65 mm long and 25 mm wide. The rated current of the coil is 10 mA. The flux density in the air gap is 4.6×10^{-3} Wb/m². The damping constant is 8×10^{-3} N-m/rad-s⁻¹. The moment of inertia is 8×10^{-3} kg-m². The spring constant is 16×10^{-3} N-m/rad. The coulomb friction is 0.2×10^{-6} N-m.

- (a) Determine if the meter is underdamped, critically damped or over-damped.
- (b) Determine the number of turns on the coil to produce a deflection of 100° at rated current.
- (c) Determine the current required to overcome coulomb friction.

Solution. (a) Damping constant $D = 8 \times 10^{-3}$ N-m/rad⁻¹ s

$$\therefore D^2 = (8 \times 10^{-3})^2 = 64 \times 10^{-6}, \quad 4JK = 4 \times 8 \times 10^{-3} \times 16 \times 10^{-3} = 512 \times 10^{-6}.$$

Hence $D^2 < 4JK$ and therefore the instrument is underdamped.

(b) Deflection $\theta = 100^\circ = 100 \times \pi/180 = 1.8$ rad.

From Eqn. 28'4, Displacement constant $G = \frac{K\theta + F}{i} = \frac{16 \times 10^{-3} \times 1.8 + 0.2 \times 10^{-6}}{10 \times 10^{-3}}$
 $= 2.88$ Nm/A.

Number of turns $N = \frac{G}{Bld} = \frac{2.88}{4.6 \times 10^{-3} \times 65 \times 10^{-3} \times 25 \times 10^{-3}} = 387000$.

(c) Current required to overcome friction $= \frac{F}{G} = \frac{0.2 \times 10^{-6}}{2.88}$ A $= 0.07 \mu$ A.

28'44. Null Type Recorders. Many recorders operate on the principle whereby a change in its input, produced by the signal from the sensor or transducer (which is used to convert a non-electrical quantity to an equivalent electric signal), upsets the balance of the measuring circuit of the recorder. As a result of this unbalance, an **Error Signal** is produced that operates some device which restores balance or brings the system to **Null conditions**. The amount of movement of this balance restoring device, then, is an indication of the magnitude of the error signal, and the direction of the movement is an indication of the direction of the quantity being measured has deviated from normal.

The signal from the transducer may take any of the several forms. It may be a voltage (a.c. or d.c.), a current (a.c. or d.c.) or it may be a value of resistance, inductance or capacitance. The recorder, therefore, must be of a type able to accept the form of the input signal.

There are a number of null type recorders. They are: (i) Potentiometric recorders (ii) Bridge recorders, and (iii) LVDT recorders.

The principle of operation for all these recorders is the same *i.e.* to obtain null condition and hence only potentiometric recorders are described.

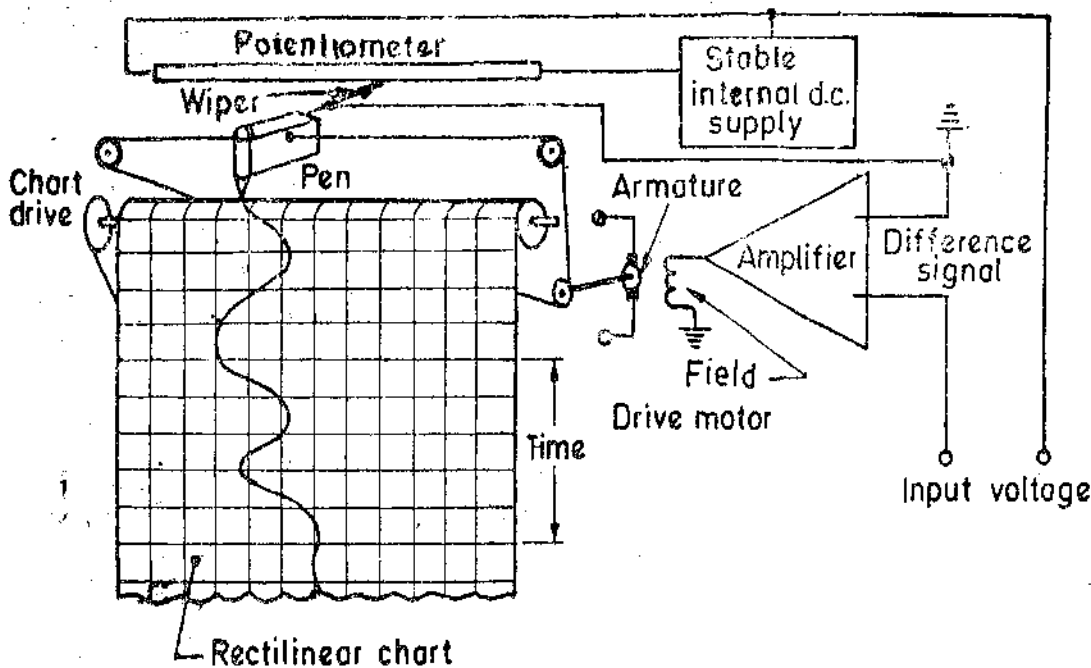

Fig. 28.51. Potentiometric type recorder.

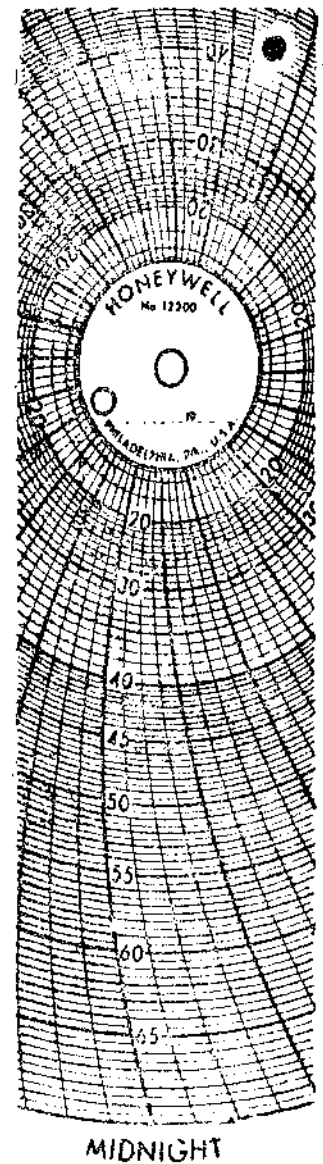

Fig. 28.52. Circular chart

28'45. Potentiometric Recorders. The basic disadvantage of a galvanometer type of recorder is that it has a low input impedance and a limited sensitivity. A simple method of overcoming the

input impedance problem is to use an amplifier between the input terminals and the display or indicating instrument. However, this technique, while producing a high input impedance (so as to reduce loading effects) and improved sensitivity, results in an instrument having low accuracy. The accuracy can be improved if the input signal is compared with a reference voltage by using a potentiometer circuit (See Fig. 28'51). The error signal, which is the difference between the input signal and the potentiometer voltage, is amplified and is used to energize the field coil of a d.c. motor. A wiper is mechanically connected to the armature of the d.c. motor. This wiper moves over the potentiometer in the appropriate direction to reduce the magnitude of the error signal and to obtain balance. The wiper comes to rest when the unknown signal voltage is balanced against the voltage of the potentiometer.

The technique results in graphical recorders having a very high input impedance, which is infinity at balance conditions. A sensitivity of 4V/mm is attained with an error of less than $\pm 0.25\%$ with a bandwidth of 0.8 Hz.

The chart drive for most potentiometric recorders is obtained from a motor synchronized to power line frequency. Different speeds may be obtained by using a gear train that uses different gear ratios.

The most common application of potentiometric recorders is for recording and control of process temperatures. This has already been described under the heading of "Self Balancing Potentiometers" in Art. 14'14 page 463.

The scale of this recorder is calibrated in terms of temperature. The chart for such a temperature recorder may be rectilinear or circular. A circular scale is shown in Fig. 28'52.

The circular chart has concentric circles ruled out. In addition it has equally spaced arcs extending from the centre to the rim of chart. These are called time arcs. The time markings are placed along the circumference of the rim. The values of the measurand lie along the arcs. These values depend upon the linkage geometry of the instrument.

28'46. Single Point Recorders

Analog recorders are available in several types. These recording instruments can be entirely mechanical, entirely electrical, or a combination of both. There are two sets of units shown. One set indicates the value of the measured variable, for example, pressure. The second set indicates time. Therefore the graphic record shows variations of pressure with time.

Instruments that record changes of only one measured variable are called **single point recorders**. The trace on such instruments is usually in the form of single continuous curve.

28'47. Multipoint Recorders

Rectangular strip chart recorders do not usually incorporate control features but many models are available in which one recorder may be used for recording several inputs. In process industry it becomes necessary to record simultaneously variables like temperature, pressure, flow rate, liquid level, etc. This feature may be performed either by having several (Maximum 4) pens which overlap each other and record the inputs simultaneously, or by replacing the pen by print wheel geared to a selector switch so that when a particular input is connected to the potentiometer balance circuit, a point plus its identifying character is printed on the chart. This form of recorder is called a **Multipoint Recorder** and may have as many as 24 inputs, with traces displayed in 6 colours.

28'48 X-Y Recorders

A strip chart recorder records the variations of a quantity with respect to time while a X-Y Recorder is an instrument which gives a graphic record of the relationship between two variables.

In strip chart recorders, usually self-balancing potentiometers are used. These self-balancing potentiometers plot the emf as a function of time. In X-Y Recorders, an emf is plotted as a function of another emf. This is done by having one self-balancing potentiometer control the position of the rolls (*i.e.*, the paper) while another self-balancing potentiometer controls the position of the recording pen (stylus).

In some X-Y recorders, one self-balancing potentiometer circuit moves a recording pen (stylus) in the X direction while another self balancing potentiometer circuit moves the recording pen (stylus) in the Y direction at right angles to the X direction, while the paper remains stationary.

There are many variations of X-Y recorders. The emf, used for operation of X-Y recorders, may not necessarily measure only voltages. The measured emf may be the output of a transducer that may measure displacement force, pressure, strain, light intensity or any other physical quantity. Thus with the help of X-Y recorders and appropriate transducers, a physical quantity may be plotted against another physical quantity.

Hence an X-Y Recorder consists of a pair of servo-systems, driving a recording pen in two axes through a proper sliding pen and moving arm arrangement, with reference to a stationary paper chart. Attenuators are used to bring the input signals to the levels acceptable by the recorder.

Fig. 28'53 shows a block diagram of a typical X-Y recorder. A signal enters each of the two channels. The signals are attenuated to the inherent full scale range of the recorder (often 0-5 mV), the signal then passes to a balance circuit where it is compared with an internal reference voltage. The error signal (i.e., the difference between the input signal voltage and the reference voltage) is fed to a chopper which converts d.c. signal to an a.c. signal. The signal is then amplified in order to actuate a servometer which is used to balance the system and hold it in balance as the value of the quantity being recorded changes.

The action described above takes place in both axes simultaneously. Thus we get a record of one variable with respect to another.

An X-Y recorder may have a sensitivity of $10 \mu\text{V}/\text{mm}$, a slewing speed of 1.5 m/s and a frequency response about 6 Hz for both the axes. The chart size is $250 \times 180 \text{ mm}$. The accuracy of X-Y recorder is about $\pm 0.3\%$.

The use of X-Y recorders in laboratories greatly simplifies and expedites many measurements and tests. A few examples are being given below :

1. Speed torque characteristics of motors.
2. Lift Drag wind tunnel tests.
3. Plotting of characteristics of vacuum tubes, zener diodes, rectifiers and transistors, etc.
4. Regulation curves of power supplies.
5. Plotting stress—strain curves, hysteresis curves and vibrations amplitude against swept frequency.
6. Electrical characteristics of materials such as resistance versus and temperature plotting the output from electronic calculators and computers.

28'49. Ultraviolet Recorders. These are basically electromechanical oscillographic recorders and are modified version of the Duddel's oscillographs (See Art. 7'26 on page 184).

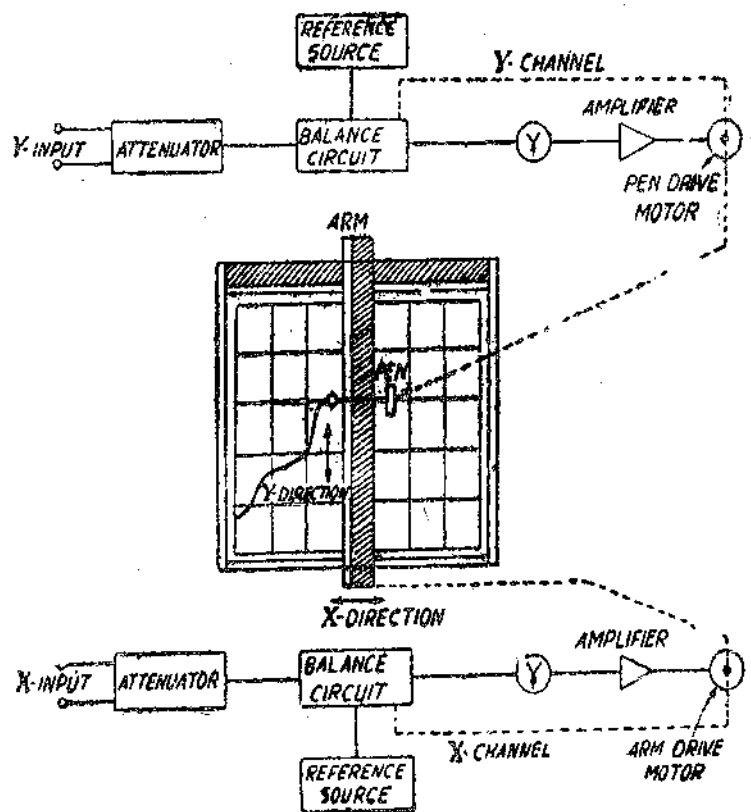

Fig. 28'53. X-Y Recorder.

The recorder consists of a number of galvanometer (moving coil) elements mounted in a single magnet block as shown in Fig. 28'54. This is unlike the Duddell's multichannel oscillograph where a separate magnet assembly is used for every galvanometer element and hence there is great reduction in size and cost. The galvanometer uses a source of ultraviolet light in place of white light. A paper sensitive to ultraviolet light is used for producing a trace for the purpose of recording. The u.v. light is projected on the paper with the help of mirrors attached to the moving coils.

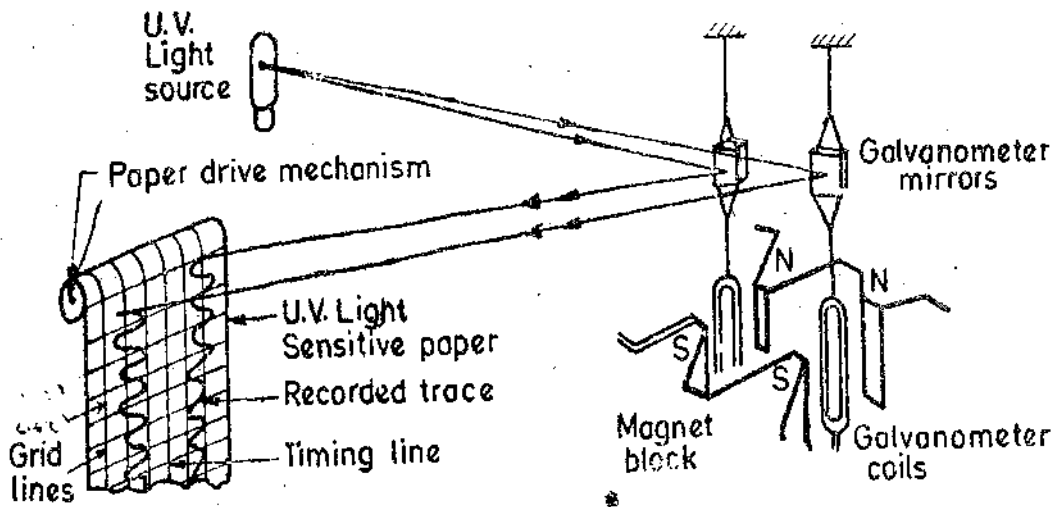

Fig. 28'54. Ultraviolet (u.v.) recorder.

28'49'1. Principle of Operation

When a current is passed through the moving (galvanometer) coil, it deflects under the influence of the magnetic field of the permanent magnet. The u.v. light falling on the mirrors is deflected and is projected on to the u.v. light sensitive paper through a lens and mirror system. The paper is driven past the moving light spot and thus a trace of variation of current with respect to time is produced. In many u.v. recorders, arrangements are provided to select a suitable paper driving speed out of as many as 12 different speeds. Some galvanometers incorporate an arrangement for controlling the speed of the paper with the help of an externally applied voltage. The u.v. sensitive paper may be processed by photodeveloped, permanized or photocopied.

The recorder, in addition to the traces of the input currents, may have the following additional traces :

(i) **Grid Lines.** These lines are along the length of the paper and may be obtained by shining the u.v. light on the paper through a comb.

(ii) **Timing Lines.** These lines are along the width of the paper and are obtained from a vapour tube actuated from an external source or an internal source of known frequency.

(iii) **Trace Identification.** The u.v. recorders are multi-channel recorders and many recorders have 25 channels. Since, each channel may produce a 100 mm wide peak to peak trace on a 30 cm wide paper, there will be considerable overlapping of traces produced by different channels. Therefore it is essential to provide an identification mark for each trace so as to avoid confusion. A simplified identification process is to interrupt each trace momentarily in turn and to coincide this interruption with a numeral marked on the side of the record by passing u.v. light through cutouts of the numeral.

28'49'2. Recorder Galvanometers. The recorder galvanometers are Pencil galvanometers. The construction and transient performance of these has been explained in Art. 7'26 (on pages 184-188).

28'49'3. Applications. The u.v. recorder may be used for d.c. and a.c. signals having a fundamental frequency up to 400 to 500 Hz. The frequency range depends on the recorder being used and paper driving speeds. The recording of high frequency inputs is possible if recorders with high paper speeds of about 10 m/s are available.

Typical applications of u.v. recorders are in recording (i) output of transducers, (ii) control system performance, and (iii) regulation transients of generators.

These recorders are also used for recording the magnitude of low frequency signals which cannot be measured with analog (pointer) type instruments.

28.50. Magnetic Tape Recorders

It is frequently desirable and in many cases necessary, to record data in such a way that they can be retrieved, or reproduced in electrical form again. The most common and most useful way of achieving this is through the use of magnetic tape recording.

The recorders described till now are basically low-frequency recorders but magnetic tape recorders have response characteristics which enable them to be used at higher frequencies. Therefore magnetic tape recorders are extensively used in Instrumentation systems.

28.50.1. Advantages of Magnetic Tape Recorders

- (i) Magnetic tape recorders have a wide frequency range from d.c. to several MHz.
- (ii) They have a wide dynamic range which exceeds 50 db. This permits the linear recording from full scale signal level to approximately 0.3% of full scale.
- (iii) They have a low distortion.
- (iv) The magnitude of the electrical input signal is stored in magnetic memory and this signal can be reproduced whenever desired. The reproduced signal can be analyzed by automatic data reduction methods.
- (v) The recorded signal is immediately available, with no time lost in processing. The recorded signal can be played back, or, reproduced as many times as desired without loss of signal.
- (vi) When the information has been processed, the tape can be erased and reused to record a new set of data.
- (vii) Magnetic tape recording permits multi-channel recording. A tape facilitates the continuous record of a number of signals, which may have a wide range of frequency, to be made simultaneously. This is a great advantage especially when recording transient and "once only" signals.
- (viii) The use of magnetic tape recorders provides a convenient method of changing the time base. Data may be recorded at very fast speeds (1.52 or 3.05 m/s) and played back at speeds (4.76 or 2.38 cm/s) slow enough to be recorded with low frequency recorders like graphic recorders.

28.50.2. Basic Components of a Tape Recorder. A magnetic tape recorder consists of the following basic components :

1. **Recording Head.** This device responds to an electrical signal in such a manner that a magnetic pattern is created in a magnetisable medium. The construction of a magnetic head as shown in Fig. 28.55 is similar to that of a transformer having a toroidal core with a coil. A fine air gap of length 5–15 μm is shunted by the passing magnetic tape. A current in the coil causes a flux of the same shape to bridge the air gap and hence to pass through the magnetic tape, thereby magnetizing the iron oxide particles as they pass the gap. The state of magnetization of the oxide as it leaves the gap is retained, thus the actual recording takes place at the trailing edge of the gap. Any signal recorded on the tape appears as a magnetic pattern dispersed in space along the tape, similar to the original coil current variation with time.

2. **Magnetic Tape.** Magnetic tape is composed of a coating of fine magnetic iron oxide particles (Fe_2O_3) on a plastic ribbon. A typical tape is 12.7 mm wide and 25.4 μm thick. The magnetic particles conform to the magnetic pattern induced in them and retain it.

3. **Reproducing Head.** The reproducing head detects the magnetic pattern stored in them and converts it back to original electrical signal. The reproducing is similar in appearance to that of a recording head.

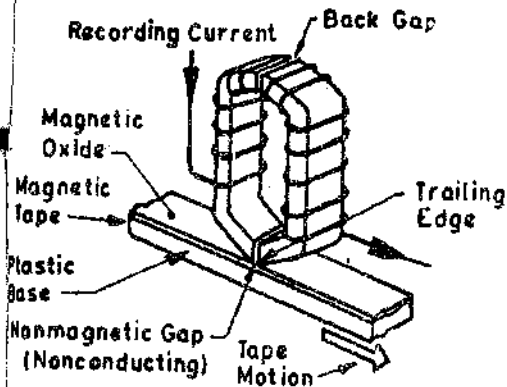

Fig. 28'55. Magnetic tape recording head.

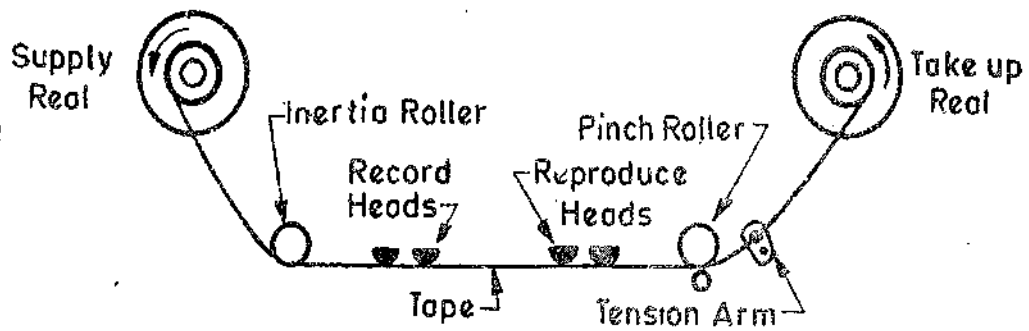

Fig. 28'56. Tape transport mechanism.

4. Tape Transport Mechanism. This mechanism moves the tape along the recording or the reproducing heads at a constant speed. The tape mechanism must be capable of handling the tape during various modes of operation without straining, distorting or wearing the tape. This requires that the mechanism must use arrangements to guide the tape past the magnetic heads with great precision, maintain proper tension and obtain sufficient tape to magnetic head contact. Arrangements for fast winding and reversing are also provided. A simple arrangement is shown in Fig. 28'56. A capstan and pinch roller are used to drive the tape. Some models use a closed loop drive.

5. Conditioning Devices. These devices consist of amplifiers and filters required for modifying the signal to a format that can be properly recorded on a tape.

28'50'3. Principle of Tape Recorders. When a magnetic tape is passed through a recording head, any signal recorded on the tape appears as magnetic pattern dispersed in space along the tape, similar to the original coil current variation with time.

The same tape when passed through a reproduce or playback head produces variations in the reluctance of the winding thereby inducing a voltage in the winding dependent upon the direction of magnetization and its magnitude on the magnetic tape. The induced voltage is proportional to rate of change of flux linkages. Therefore the emf induced in the winding of reproducing head is proportional to rate of change of the level of magnetization on the tape, i.e. $e_{rep} \propto N \frac{d\phi}{dt}$, where N is the number of turns of the winding put on the reproduce head. Since the voltage in the reproduce head is proportional to $\frac{d\phi}{dt}$, the reproduce head acts as a differentiator.

For example, let the original signal be $A \sin \omega t$. The current in the record head winding and the flux produced will be proportional to this voltage,

$$\therefore \phi = K_1 A \sin \omega t \text{ where } K_1 = \text{constant}$$

Assuming that the tape retains this flux pattern and regenerates it in the reproduce head, the voltage induced in the reproduce head winding is :

$$e_{rep} = N \frac{d\phi}{dt} = K_1 N A \omega \cos \omega t = K_2 A \omega \cos \omega t \quad \dots(28'42)$$

Thus the output signal from the reproduce head is a derivative of the input signal. The magnitude of the output signal is not only proportional to the flux recorded on the tape but also the frequency of the recorded signal.

It is clear from Eqn. 28'42 that the output doubles for every octave rise of frequency of the recording signal, and therefore the reproduced head output is subject to a 6 db octave rise. (See Fig. 28'57). Since, the recording is done at a constant current level for all frequencies, and therefore, in order to have an overall flat frequency response, *i.e.*, a high fidelity the reproduce head characteristics and the characteristics of the amplifier connected in the reproduce head circuit must be complementary, *i.e.*, the amplifier must have a response of -6 db/octave as shown in Fig. 28'57. This process of compensation is known as Equalisation.

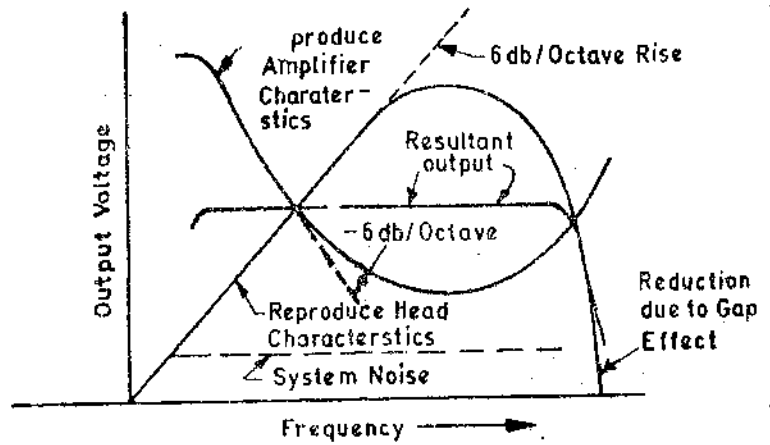

Fig. 28'57. Reproduce head and reproduce amplifier characteristics and equalization.

28'50'4. Methods of Recording.

There are three methods of magnetic tape recording which are used for instrumentation purposes. They are : (i) Direct recording, (ii) Frequency Modulation (FM) recording, and, (iii) Pulse Duration Modulation (PM) recording. Frequency modulation (FM) recorders are generally used for instrumentation purposes. The PDM recording is used in instrumentation systems for special applications where a large number of slowly changing variables have to be recorded simultaneously.

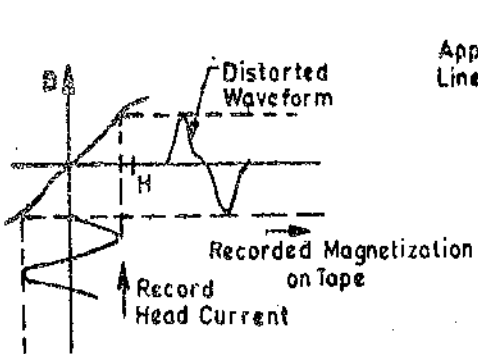

Fig. 28'58. Distortion due to non-linear B-H magnetization curve of magnetic tape.

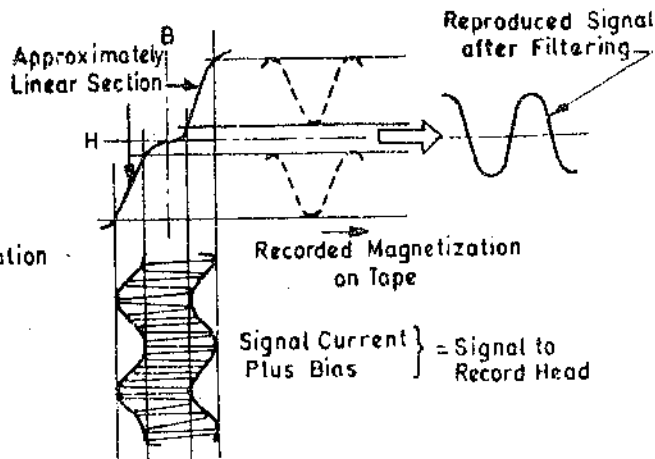

Fig 28'59. Representation of 'direct recording.

28'51. Direct Recording. It is the simplest method of recording and usually requires one tape track for each channel. The signal to be recorded is amplified mixed with a high frequency bias and fed directly to the recording head as a varying electric current. The reason for introducing bias is explained below :

The magnetic pattern impressed upon the tape is directly proportional to the flux density produced at the air gap. The relationship between current in the winding and the flux density in the gap is non-linear. This non-linearity produces a distortion in the signal applied to the tape as shown in Fig 28'58 where input signal is sinusoidal while the magnetization produced on the tape is non-sinusoidal. In order to avoid distortion, a high frequency bias of constant amplitude is applied with the signal input to the recorder. Both the amplitude and frequency of the bias is larger than the maximum amplitude and highest frequency contained in the input signal. The bias frequency is usually four times the highest signal frequency. The bias current is usually between 5 to 30 times the signal current and the exact value depends the tape and head characteristics. The combining of the bias and the input signal is accomplished by a linear mixing process (and is not an amplitude modulation process):

The combined input and bias signal is shown in Fig. 28'58. This is the signal which is applied to the record head. When the magnitude of the input signal is limited so that the peak values of input plus bias signal lie on the straight portion of BH curve of tape material, the waveform recorded as shown in Fig. 28'59. When the tape is passed through the reproduce head, this very waveform is reproduced. This waveform is conditioned by filtering out the high frequency component, thus reproducing the waveform of the original signal. The output signal may be amplified to give a suitable magnitude.

Fig. 28'57 shows that, as the recorded frequency approaches zero, the output drastically falls down to zero (since the output voltage of the reproduce head is proportional to frequency). Thus direct recording process cannot be used for d.c. (as the reproduce head voltage is zero for d.c. signals). Direct recording cannot function below a certain frequency. As the frequency decreases, the output of the reproduce head decreases. A limit is reached when the reproduce head voltage is equal to the voltage due to the inherent noise in the system. If the system is used below the frequency, the signal will be completely shrouded by the noise signal. The lower operating frequency for direct recording is 50 Hz.

The high-frequency limitation of direct recording is limited by the gap length of the reproduce head. When a tape moves past the record air gap, the wavelength on the tape is given by

$$\lambda = v/f \text{ m} \quad \dots(28'43)$$

where v = tape speed ; m/s and f = frequency of recorded signal ; Hz.

Now, if the reproduce head gap has a width which is significant proportion of λ , then the reproduce circuits cannot respond to small changes in the signal. Therefore, it follows that the gap length in the reproduce head must be small compared with the wavelength of the highest frequency to be detected. Thus, as the speed of the tape is increased, the wavelength at any given frequency is increased, thereby increasing the frequency response of the system. If a gap length of $6.4 \mu\text{m}$ is used at a speed of 1524 mm/s, a response of 100 kHz is typical. The smallest gap length is $1.3 \mu\text{m}$ and with this gap length the maximum response is about 1 MHz for a tape speed of 3048 mm/s.

In fact the high frequency response of the direct recording system is limited by several factors, the most important of which is the gap length of the reproducing head. The output voltage of the reproducing head increases with frequency, simply because $d\phi/dt$ increases. This is true upto the point where the length of gap equals one-half the recorded wavelength. Beyond this point the output voltage decreases rapidly and drops to zero when the gap lengths equals the recorded wavelength. At this point there is no magnetic gradient spanned and therefore the output voltage is zero. This phenomenon is called gap effect and is most serious restriction on the high frequency response of the tape recorder. (See Fig. 28'57).

In the erase head a signal of high frequency and level sweeps the magnetic tape thereby completely wiping out the information contained therein. This renders the magnetic tape to be used afresh for another signal.

28'51'1. Advantages of Direct Recording

(i) This recording process has a wide frequency response ranging from 50 Hz to about 2 MHz for a tape speed of 3.05 m/s. It provides the greatest bandwidth obtainable from a given recorder.

(ii) It requires only simple, moderately priced electronic circuitry.

(iii) It has a good dynamic response and takes overloads without increase in distortion. The dynamic range or signal-to-noise (S/N) ratio is usually quoted in decibels and is defined as the ratio of maximum signal to the minimum signal which can be recorded at a certain amount of total harmonic distortion (THD). In general the instrumentation recorders have a S/N ratio of 22 db to 30 db at 1 per cent THD and a frequency down to 400 Hz.

(iv) It is used to record signals where information is contained in the relation between frequency and amplitude, such as spectrum analysis of noise,

(v) It can be used for recording voice and in multiplexing a number of channels of information into one channel of tape recording.

28.51.2. Disadvantages of Direct Recording

(i) The direct recording process is characterised by some amplitude instability caused by random surface inhomogeneities in tape coating. Some portions of the tape may not be perfectly recorded owing to dirt or poor manufacture, and this is called "Drop Out". At long wavelengths (low frequencies) the amplitude variations caused by inhomogeneities may be only a few percent; however for frequencies near the upper bandwidth limit, for a given tape speed, amplitude variations can exceed 10% and momentary decreases of over 50% due to drop outs may occur. This also shows one of the difficulties associated with magnetic digital tape recording.

(ii) The direct recording is used only when maximum bandwidth is required and when variations in amplitude are acceptable.

(iii) The direct recording, no doubt, can be used for Instrumentation purposes but it is mainly used for recording of speech and music. In sound recordings, the ear averages the amplitude variation errors. While, the audio tape recorder utilizes the direct recording process, it is seldom satisfactory to use an audio recorder for Instrumentation purposes. The audio tape recorder is designed to take advantage of the rather peculiar spectral energy characteristics of speech and music, whereas the requirements of Instrumentation recorder are uniform response over its entire range.

28.52. Frequency Modulated (FM) Recording. Frequency modulation (FM) as the name implies, uses the variation of frequency to carry the desired information instead of varying the amplitude. (See Art. 27.7.3, page 897).

The frequency modulation overcomes some of the basic limitations of the direct recording process at the cost of high frequency response.

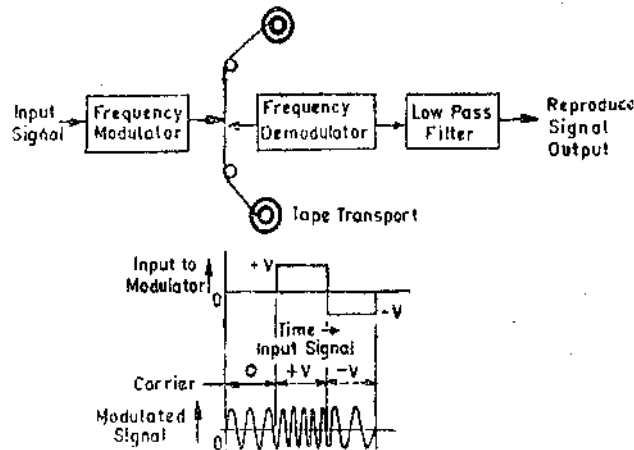

Fig. 28.60. Frequency modulation (FM) recording system.

This system is shown in Fig. 28.60. In this system a carrier oscillator frequency, f_c , (called centre frequency) is modulated by the level of the input signal. When the input is zero, the modulation contains oscillation with a centre frequency f_c . Application of a positive input voltage deviates the carrier frequency by a specified percentage in one direction, whereas application of a negative voltage deviates the frequency by an appropriate percentage in the opposite direction. The output of the modulation which is fed to the tape is a signal of constant frequency for d.c. inputs while for a.c. inputs the signal is of varying frequency. The variation of frequency is directly proportional to the amplitude of input signal. On playback the output of the reproduce head is modulated and fed through a filter which removes the carrier and other unwanted frequencies produced due to modulation process.

The operation of an FM modulator can easily be checked by applying a known input voltage and measuring the output frequency with an electronic counter. This signal is applied to the tape with

no further conditioning, as the signal is independent of the amplitude. The FM demodulator converts the difference between centre frequency and the frequency on the tape to a voltage proportional to the difference in the frequencies. This system can thus record frequencies from d.c. to several thousand Hz. Residual carrier signals and any out of band noise are removed by a low pass filter

There are two important factors in FM recording :

1. **Percentage Deviation.** It is defined as the carrier deviation to centre frequency.

$$\therefore \text{Percentage deviation or modulation index } m = \frac{\Delta f}{f_c} \times 100 \quad \dots(28'44)$$

where Δf = carrier deviation from centre frequency, and f_c = centre or carrier frequency.

In a typical FM recording system $\pm 40\%$ deviation of the carrier frequency corresponds to plus and minus full scale of input signal. To illustrate this, let the centre frequency be 50,000 Hz. Let an input signal of 40 percent deviation be applied to the modulator. Hence from Equ. 28'44.

$$\text{carrier deviation from centre frequency, } \Delta f = \frac{mf_c}{100} = \frac{40 \times 50,000}{100} = 20,000 \text{ Hz.}$$

Thus an 1 volt input will produce an output frequency of : $f_0 + \Delta f = 50,000 + 20,000 = 70,000$ Hz from the modulator.

Now let us apply d.c. to the same modulator. In this case $m=0$ and therefore $\Delta f=0$. Hence the output of the modulator has a frequency of $f_0 + \Delta f = 50,000$ Hz.

2. **Deviation Ratio.** It is defined as the ratio of carrier deviation from centre frequency to signal or modulating frequency.

$$\therefore \text{Deviation factor } \delta = \frac{\Delta f}{f_m} \quad \dots(28'45)$$

where f_m = data signal (frequency of the input signal to the modulator).

A system with a high deviation ratio generally has a low noise figure. However, Δf is limited by recorder bandwidth and f_m must be kept high to accommodate all the data signals.

28'52'1. Advantages of FM Recording. (i) FM recording is useful primarily when the d.c. component of the input signal is to be preserved or when the amplitude variations of the direct recording process cannot be tolerated.

(ii) This system has wide frequency range and can record from d.c. voltages to several kHz.

(iii) It is free from dropout effects.

(iv) It is independent of amplitude variations and accurately reproduces the waveform of the input signal.

(v) It is used extensively for recording the voltages from the force, pressure and acceleration transducers.

(vi) It is extremely useful to for multiplexing in instrumentation systems.

28'52'2. Disadvantages of FM Recording. (i) FM recording is extremely sensitive to tape speed fluctuations (flutter). This is because, in either the recording or reproducing mode, tape speed variations introduce unwanted apparent modulation of the carrier (noise), reducing the dynamic range of the system. With a low percentage deviation, such as 7.5% in FM telemetry subcarrier systems, the effect of flutter becomes pronounced. For example, a 1 percent deviation caused by flutter in a system having 7.5 percent deviation corresponds to $1/7.5 \times 100 = 13.3$ percent noise. The same flutter imposed on a 40 percent deviation system causes only $1/40 \times 100 = 2.5$ percent noise signal. Thus system with a higher percentage deviation are generally less influenced by tape speed variations.

(ii) This circuitry of an FM recording system is more complicated than that of a direct recording system. This complexity of circuitry is on account of separate modulation systems.

(iii) The FM system has a limited high frequency response of about 80 kHz.

(iv) It requires a high tape speed.

(v) It requires a high quality of tape transport and speed control and, therefore, expensive than the direct recording system.

To sum up, a well designed FM system gives a reasonably good amplitude accuracy of the order of 1% against 5% given by direct recording, d.c. response and d.c. linearity and low distortion.

Frequency response for a given tape speed is greatly reduced, and the recording and reproducing circuits are much more complex than those of the direct recording system. In order to keep the flutter figure low the tape transport mechanism must be of good design that runs the tape at a constant speed.

28'53. Pulse Duration Modulation (PDM) Recording

Pulse duration modulation (PDM) is sometimes used to allow simultaneous recording of a large number of slowly changing variables by using time-division multiplexing (TDM).

The PDM recording process requires the input signal at the instant of sampling be converted to a pulse, the duration of which is proportional to the amplitude of the signal at that instant. As an example, for recording a sine wave, it is sampled and recorded at uniformly spaced discrete intervals instead of continuously recording the instantaneous values. The original sine wave can be reconstructed on playback by passing the discrete readings through an appropriate filter.

A schematic diagram of PDM recording system employing TDM for a sine wave signal is shown in Fig. 28'61

The system makes 900 samples through 90 scanner (multiplexer) positions. The number of channels per track are 86 provided that the input frequencies are less than 1.5 Hz. The rest of the four scanner positions are used for zero and maximum voltage levels and for synchronizing purposes.

28'53'1. **Advantages of PDM Recording.** The major advantages of a PDM recording system are :

- (i) It has the ability to simultaneously record information from a large number of channels.
- (ii) It has a high accuracy due to the fact that it can be self-calibrated.
- (iii) It has a high S/N ratio.

28'53'2. **Disadvantages of PDM Recording.** The disadvantages of a PDM recording system are :

- (i) It has a limited frequency response.
- (ii) It has a highly complex electronic circuitry and therefore the reliability of such systems is low.
- (iii) it is used only for special applications such as flight recorders, where a large number of slowly changing variables are involved.

Example 28'20. The gap of a tape recorder is $6.25 \mu\text{m}$. Determine the speed of the tape so has to have a satisfactory response at 50,000 Hz. Assume that recorded wavelength must be greater than 2.5 times the gap of the recorder.

Solution. Minimum recorded wavelength $\lambda = 2.5 \times 6.25 = 15.625 \mu\text{m}$.

For satisfactory operation, minimum tape speed is :

$$v = \lambda f = 15.625 \times 10^{-6} \times 50,000 = 7.8125 \text{ m/s.}$$

Example 28'21. A tape receives 12,000 numbers per second. The tape speed is 1.5 m/s. Determine the number density of the tape.

Solution.

$$\text{Number density} = \frac{\text{number received/second}}{\text{speed/second}} = \frac{12000}{1.5} \text{ numbers/m} = 8 \text{ numbers/mm.}$$

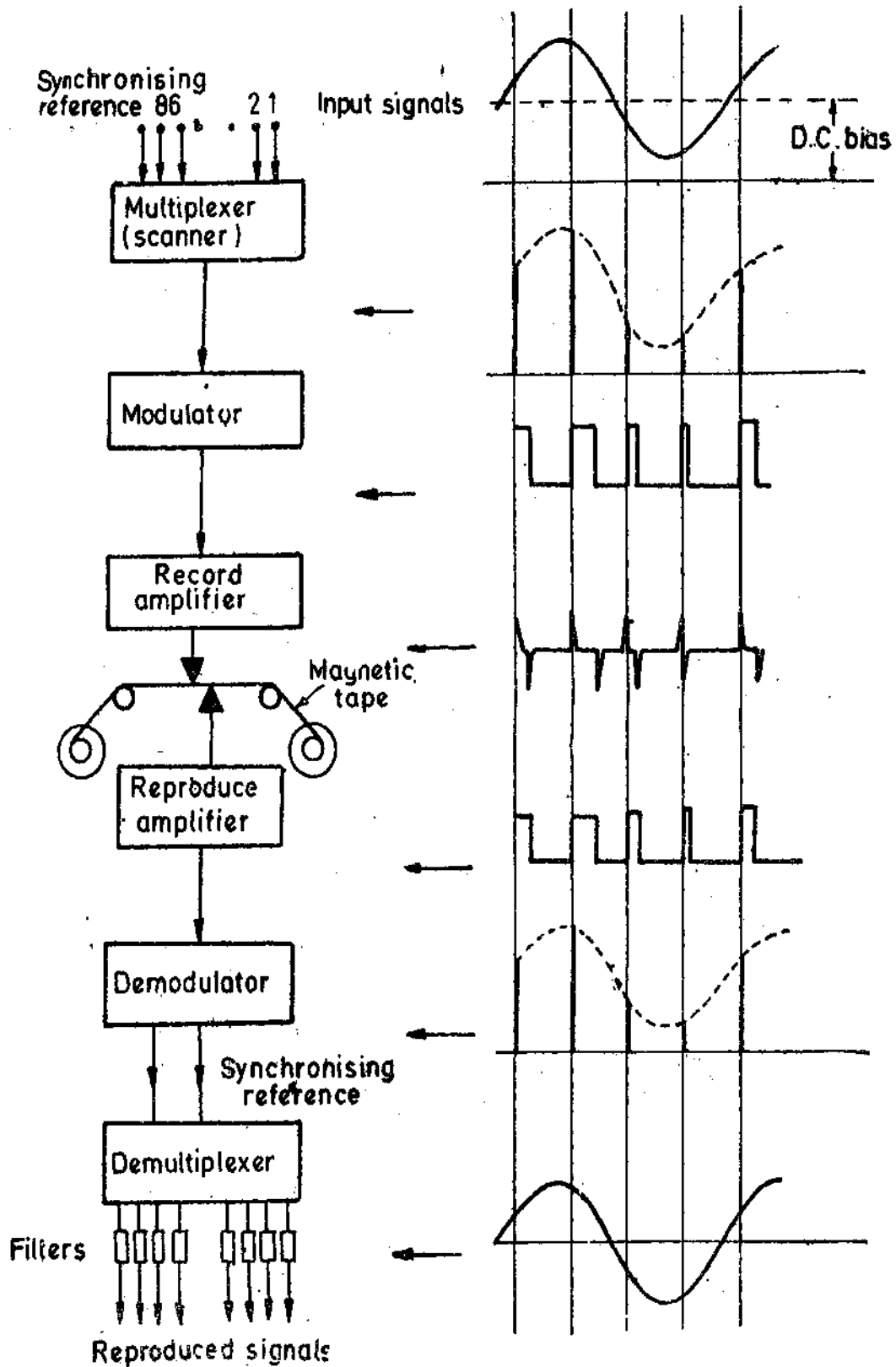

Fig. 28'61. Schematic diagram of Pulse Duration Modulation (PDM) recording system.

28'54. Digital Tape Recorders. Digital tape recorders are generally used as storage devices in data processing applications. Digital tape units are generally of two types :

- (i) Synchronous, and
- (ii) Incremental.

The incremental digital recorder is commanded to step ahead for each digital character to be

recorded. The input data may then be at a relatively slow or even at a discontinuous rate. In this way, each character is equally and precisely spaced along the tape.

In the synchronous digital recorder, the tape moves at a constant speed (say 0.75 m/s) while a large number of characters are recorded. The data inputs are at precise rates up to tens of thousands of characters per second. The tape is rapidly brought up to speed, recording takes place, and the tape is brought to a fast stop. In this way a block of characters (a record) is written with each character spaced equally along the tape. Blocks of data are usually separated from each other by an erased area on the tape called a "record gap". The synchronous unit starts and stops the tape for each block of data to be recorded.

Characters are represented on magnetic tape by combination of 1-bits in the appropriate tracks across the tape width.

Instrumentation systems and computers use binary codes made up of combination of two symbols: 0 and 1. As far as digital tapes are concerned a positive magnetized space at a given place on a magnetic tape with a negative magnetization on the tape before or after this place on the magnetic tape may express a 1, and no change in the negative magnetization at a given place on the magnetic tape may express a 0. This system of expressing 1's and 0's is defined as the return to zero (RZ) method. This method is illustrated by the graph of Fig. 28.62.

The recording technique used in most instrumentation recorders is the industry accepted IBM NRZ recording. This method uses the change from either a positive to a negative or from a negative to positive state to express a 1 at a given place on the tape, and no change of state at given place on the tape to express a 0. This method is defined as non-return-to zero (NRZ) method and is illustrated by graph of Fig. 28.63.

The code for a given number may be expressed as a series of pulses on a single channel representing the desired combination of 1's and 0's by either the RZ or NRZ method. This is a serial system of writing numbers. A faster and more common system uses a multichannel tape and inscribes the common number at a given place on the tape. This requires a recording channel for each of the digits, 1 or 0, required to express the number. This is a parallel system of writing numbers.

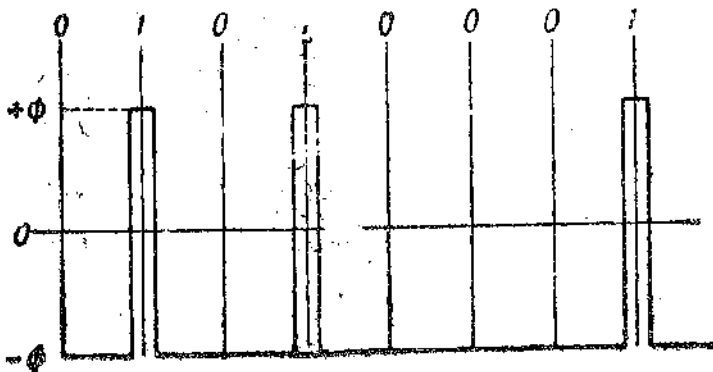

Fig. 28.62. RZ digital recording.

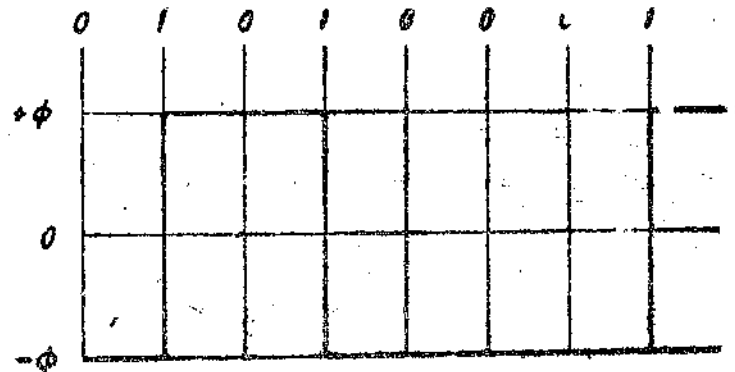

Fig. 28.63. NRZ digital recording.

The process of recording numbers in a digital coded form is very simple. It requires only an amplifier in the recorder and another amplifier in the reproducer to condition the signal. The "on" and "off" conditions are neither a function of frequency nor of amplitude. Yet there are a few problems in the digital recording.

The major problem is the dropout errors or loss of pulses and spurious (extraneous) pulses. The loss of pulses becomes more critical as the rate of pulses decreases. This is expressed in pulses per mm of tape. Many recorders use 8 pulses/mm and 2.4 m/s (240 mm/s) speed, but some tape

recorders use 20 pulses/mm and a speed of a 4.8 m/s (480 mm/s). Packing densities greater than 40 pulses/mm have been obtained.

As a check on the dropout errors, some systems record the information twice. Thus it is called use of redundancy (because the second recording would be redundant if the system were perfect).

A second method uses the logic of the number code to indicate, on a separate channel of the tape, if one of the 1's is missing. If an even number of 1's is missing, no error is recorded. This is known as parity check. Systems of parity checking have been developed which check not only the words written across the tape but also that of the numbers recorded in each of the tape channels. In some equipment the parity checks have been used to insert the missing information due to dropouts on the magnetic tape, as well as to indicate the errors that have been made. Thus this system is very effective in detecting and reducing tape dropout errors.

In parallel recording of digital information the recording head and the reproducing head should be at right angles to the tape. If the tape becomes skewed, the signals cannot be read at the same time and hence errors will be introduced. Thus an accurate alignment of tape is necessary to avoid this error.

28.54.1. Advantages of Digital Tape Recording. The advantages of digital tape recording are :

- (i) high accuracy,
- (ii) insensitivity to tape speed,
- (iii) use of simple conditioning equipment, and
- (iv) the information can be fed directly to a digital computers for processing and control.

28.54.2. Disadvantages of Digital tape Recording. The disadvantages of digital tape recording are :

- (i) Poor tape economy.
- (ii) The information from transducers is mostly in analog format and hence this system requires an analog to digital converter to prepare digital information for the tape recorder.
- (iii) A high quality of tape and tape transport mechanism is required.

UNSOLVED PROBLEMS

1. A $3\frac{1}{2}$ digit voltmeter is used for measuring voltage.

- (a) Find the resolution of the instrument.
- (b) How would a voltage of 14.53 V be displayed on 10 V scale ?
- (c) How would a reading of 14.53 V be displaced on 100 V scale ? [Ans. (a) 0.001 (b) 14.53 (c) 0.145]

2. The lowest range on a $4\frac{1}{2}$ digit DVM is 10 mV full scale. What is sensitivity of this meter. [Ans. 1 μ V]

3. A certain $3\frac{1}{2}$ digit DVM has an accuracy specifications of ± 0.5 per cent of reading ± 2 digits.

- (a) What is the possible error, in volt, when the instrument is reading 5.00 V on its 10 V range ?
- (b) What is the possible error in volt, when reading 0.10 V on the 10 V range ?
- (c) What percentage of the reading is the possible error in the case of (b) ?

Comment upon the result. [Ans. (a) ± 0.45 V (b) ± 0.0205 V (c) 20.5%]

4. Gating periods of 1 ms, 10 ms, 100 ms, 1 s, 10 s are provided on a digital counter-timer-frequency meter having a 4 digit display. When a gating period is used a reading of 0095 is obtained.

- (a) Find the likely frequency ?
- (b) What steps should be taken to obtain most accurate result ?
- (c) Suppose the frequency is 2.745 kHz, find the display for various gating times. [Ans. (a) 9500 Hz (b) select a gating time of 1 s (c) 0027, 0274, 2745, overflow]

5. The gap of a reproducing head in a tape recorder is $6.4 \mu\text{m}$. Determine the minimum speed of the tape for satisfactory response at 50 kHz. Assume the wavelength on the tape is greater than 2.5 times the gap length. [Ans. 0.8 m/s]

Measurement of Non-Electrical Quantities

MEASUREMENT OF LINEAR DISPLACEMENT

29'1. Linear Displacement Transducers

Most of the transducers which are used for measurement of linear displacement have already been described in great details in Chapter 25. These transducers are :

- | | |
|--|--|
| (i) Resistive potentiometers, | (ii) Strain gauges, |
| (iii) Variable inductance transducers, | (iv) Linear variable differential transformers (LVDT), |
| (v) Capacitive transducers, | (vi) Piezo-electric transducers, |
| (vii) Ionization transducers, and | (viii) Digital transducers. |

MEASUREMENT OF ROTARY DISPLACEMENT

29'2. Rotary Displacement Transducers

The transducers required for measurement of rotary displacement have been described in detail in Chapter 25. These transducers are :

- | | |
|---|----------------------|
| (i) Resistive potentiometers, | |
| (ii) Variable inductance transducers, | |
| (iii) Rotary variable differential transformers (RVDT), | |
| (iv) Variable reluctance transducer, | (v) Synchros, |
| (vi) Capacitive transducers, | (vii) Shaft Encoder. |

STRAIN GAUGES AND MEASUREMENT OF STRAIN

29'3. Strain Gauge Circuits

The theory and construction of strain gauges have already been explained in Art. 25'30 page 765.

The gauge factor of a strain gauge is given by Eqn. 25'30 page 766).

$$\text{Gauge factor} \quad G_f = \frac{\Delta R/R}{\epsilon} = 1 + 2\nu + \frac{\Delta p/p}{\epsilon} \quad \dots(29'1)$$

The various symbols have already been explained.

When we consider the sensitivity of a metallic strain gauge, we find that it is extremely versatile and reliable.

Typical values of gauge factor and resistance for commonly used strain gauges are :

$$G_f = 2 \text{ and } R = 120 \Omega.$$

Strain gauges are used for measurements of strains as low as 1 microstrain and therefore the corresponding change in resistance is :

$$\Delta R = G_f \epsilon R = 2 \times 10^{-6} \times 120 = 240 \times 10^{-6} \Omega = 0.00024 \Omega$$

This small change in resistance which is 0.0002% of original resistance has to be measured. It is quite evident that in order to measure a change in resistance of this low order will require the use of extremely sensitive and sophisticated instrumentation.

Strain gauges utilize circuits like voltage measuring potentiometer circuits, ballast circuits and Wheatstone bridges which have already been described. The purpose here is to review them.

29.4. Ballast Circuit

The ballast circuit has been described in Art. 26.18 page 864. Fig. 29.1 shows a ballast circuit using a strain gauge.

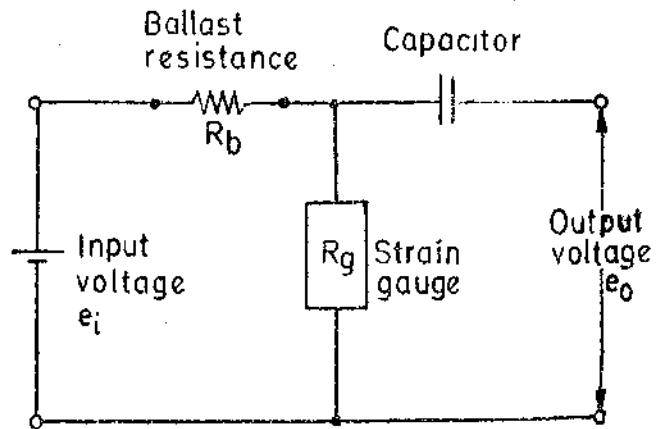

Fig. 29.1 Strain gauge using ballast circuit

If the R_g is the resistance of strain gauge the output voltage when the gauge is not strained

$$e_0 = \frac{R_g}{R_b + R_g} e_i \quad \dots(29.2)$$

∴ Change in output voltage when the gauge is strained :

$$de_0 = \frac{R_b}{(R_b + R_g)^2} dR_g \cdot e_i = \frac{R_b R_g}{(R_b + R_g)^2} \frac{dR_g}{R_g} e_i = \frac{R_b R_g}{(R_b + R_g)^2} G_f \epsilon e_i \quad \dots(29.3)$$

∴ Change in output voltage when the gauge is strained is directly proportional to the strain.

Maximum sensitivity is obtained when the ballast resistance is equal to the unstrained resistance of the gauge or $R_b = R_g$. For this arrangement.

change in output voltage when the gauge is strained $\Delta e_0 = \frac{G_f \epsilon}{4} e_i \quad \dots(29.4)$

Some of the inherent limitations in the ballast circuit can be explained by the following example.

Consider a gauge of resistance of 120 Ω and gauge factor of 2. Let the input voltage be 8 V. The voltage across the strain gauge when it is not strained is $e_0 = e_i/2 = 4$ V.

When the strain gauge is subjected to strain, the change in output voltage is :

$$\Delta e_0 = 2 \times \frac{8}{4} \epsilon = 4\epsilon.$$

Now if a strain equal to 1 microstrain is to be measured the change in output voltage is :

$$\Delta e_0 = 4 \times 1 \times 10^{-6} = 4 \times 10^{-6} = 4 \mu\text{V}.$$

Thus the indicator connected to output terminals to provide indication of strain must sense a change of voltage of 4 μV in a range of 4 V i.e. a change 0.0001%. This is a stringent requirement which practically eliminates the use of ballast circuits for static strain measurements. However, the circuit is used for dynamic strain measurements where static strain components are ignored. Thus a capacitor is connected in series in one of the leads as shown in Fig. 29.1. It acts as a high pass filter. It does not allow d.c components of output voltage on account of static strain to go to output terminals. Only a.c. output voltage components due to dynamic strains are allowed to pass.

Example. 29.1. A strain gauge having a resistance 100 Ω and gauge factor of 2 is connected in series with a ballast resistance of 100 Ω across a 12 V, supply. Calculate the difference between the output voltage with no stress applied and a stress of 140 MN/m². The modulus of elasticity is 200 GN/m².

Solution. When no stress is applied voltage across the gauge :

$$= \frac{R_g}{R_b + R_g} \cdot e_i = \frac{100}{100 + 100} \times 12 = 6 \text{ V}.$$

Strain $e = s/E = (140 \times 10^6 / 200 \times 10^9) = 0.7 \times 10^{-3}$
 Change in resistance of gauge $\Delta R_g = G_f \epsilon R_g = 2 \times 0.7 \times 10^{-3} \times 100 = 0.14 \Omega$.

\therefore Voltage across the gauge when stress is applied :

$$= \frac{100 + 0.14}{100 + 100 + 0.14} \times 12 = 6.00042 \text{ V.}$$

Change in voltage $= 6.00042 - 6 = 0.00042 \text{ V} = 0.42 \text{ mV}$

Example 29.2. A strain gauge having a resistance of 120Ω and a gauge factor of 2 is subjected to a strain of $(20 + 10 \sin 314 t) \times 10^{-6}$.

(a) Find the expression for the change in output voltage when the strain gauge is connected in ballast circuit having a ballast resistance of 120Ω and an input voltage of 6 V.

(b) If a capacitor is connected in one of the output leads and a true rms reading voltmeter of infinite impedance is connected across the output terminals, find the reading of the voltmeter.

Solution.

$$(a) \text{ Change in output voltage } \Delta e_0 = \frac{G_f}{4} \epsilon e_i = \frac{2}{4} \times 6 \times [20 + 10 \sin 314 t] \times 10^{-6} \text{ V}$$

$$= [60 + 30 \sin 314 t] \times 10^{-6} \text{ V} = [60 + 30 \sin 314 t] \mu\text{V.}$$

(b) When a capacitor is connected in series with one of the leads, the d.c. component is blocked and only the a.c. component is allowed to pass.

\therefore Signal applied to a true rms reading voltmeter $= 30 \sin 314 t \mu\text{V.}$

\therefore Reading of voltmeter $= \text{rms value of output voltage} = 30 / \sqrt{2} = 21.2 \mu\text{V.}$

29.5. Wheatstone Bridges

The Wheatstone bridge is of two types :

(i) Null type,

and (ii) Deflection type.

29.5.1. Null Type Wheatstone Bridge. The null type Wheatstone bridge is shown in Fig. 26.52 page 866. When the bridge is unbalanced on account of change in resistance ΔR_1 of arm 1, the resistance required to balance it is $\Delta R_2 = \Delta R_1 (R_3/R_4)$.

Suppose arm 1 is composed of a strain gauge having a resistance R_g and initially with

$$R_2 = R_3 = R_4 = R_g$$

$\therefore \Delta R_2 = \Delta R_g$ where $\Delta R_g = \text{change in the value of gauge resistance when strained.}$

But $\Delta R_g = G_f \epsilon R_g$

and $\therefore \Delta R_2 = G_f \epsilon R_g$

Hence change in the value of resistance R_2 is a direct measure of strain.

29.5.2. Deflection type Wheatstone Bridges. There are two types of deflection type Wheatstone bridges as described in Art. 26.20.2. page 867. They are :

(i) voltage sensitive bridge,

and (ii) current sensitive bridge.

Voltage Sensitive Bridge. The output of a voltage sensitive bridges when the resistance of arm 1 is changed is given by :

$$\Delta e_0 = \left[\frac{\Delta R_1/R}{4 + 2(\Delta R_1/R)} \right] e_i \quad (\text{see Eqn. 29.4})$$

This relationship pertains to a condition wherein the values of resistances of all the arms are initially equal, i.e., $R_1 = R_2 = R_3 = R_4 = R$ and the unbalance is created on account of change of resistance equal to ΔR_1 in R_1

Suppose now the strain gauge is in arm 1 and unstrained resistance of gauge is equal to R_g . The bridge is balanced initially with : $R_g = R_1 = R_2 = R_3 = R_4$,

When the strain gauge is subjected to strain, its value changes by ΔR_g .

$$\therefore \text{Output voltage } \Delta e_0 = \left[\frac{(\Delta R_g/R_g)}{4 + 2(\Delta R_g/R_g)} \right] e_i$$

However, the change in the value of resistance is quite small and therefore : $2\Delta R_g/R_g \ll 4$

$$\text{Hence } \Delta e_0 = \frac{\Delta R_g/R_g}{4} e_i = \frac{G_f \epsilon}{4} e_i$$

Therefore the change in output voltage is linearly proportional to strain. This bridge is called a **Quarter Bridge** since only one of the four arms contains an **Active Gauge**.

Current Sensitive Bridge. The analysis of this bridge can be done by using Thevenin theorem. The meter current under unbalance conditions is directly proportional to the strain.

Example 29'3. A Wheatstone bridge is shown on page 866 $R_3 = R_4 = 100 \Omega$. The galvanometer resistance is 50Ω . The strain gauge is connected in arm 1 and has an unstrained resistance of 120Ω . The value of R_2 is adjusted for balance under zero strain conditions. The gauge factor is 2. Calculate the galvanometer current when a strain of $400 \mu\text{m/m}$ is applied. Take the battery voltage as 4 V . Calculate the voltage output when a meter of infinite impedance is connected across output terminals.

Solution. Suppose the strain gauge forms arm 1 of the bridge. The value of R_2 for initial balance is 120Ω .

Resistance of gauge when strained $R_1 = 120(1 + 2 \times 400 \times 10^{-6}) = 120.096 \Omega$.

This causes unbalance resulting in the appearance of an output voltage.

The value of Thevenin source voltage is :

$$e_0 = \left[\frac{R_1}{R_1 + R_2} - \frac{R_3}{R_3 + R_4} \right] e_i = \left[\frac{120.096}{120.096 + 120} - \frac{100}{100 + 100} \right] \times 4 = 800 \mu\text{V}.$$

The Thevenin source resistance can be found by short circuiting the battery terminals and finding the resistance looking into output terminals. Thevenin source resistance is :

$$R_0 = \frac{120 \times 120}{120 + 120} + \frac{100 \times 100}{100 + 100} = 110 \Omega.$$

$$\therefore \text{Meter current } I_m = \frac{e_0}{R_0 + R_m} = \frac{800 \times 10^{-6}}{110 + 50} = 5 \times 10^{-6} \text{ A} = 5 \mu\text{A}.$$

29'6. Gauge Sensitivity

Fig. 29'2 shows a single strain gauge mounted on a cantilever beam. When a force is applied to the beam, the gauge is subjected to a tensile stress. Therefore, the resistance of the strain gauge increases. This increase in resistance is measured using a Wheatstone bridge as shown in Fig. 29'3.

The bridge is balanced under unstrained conditions, but becomes unbalanced when the gauge is strained.

$$\text{The change in resistance of gauge } \Delta R_{g1} = \Delta R_2 \frac{R_3}{R_4}$$

where ΔR_2 = change in R_2 , to rebalance the bridge after the strain is applied.

$$\text{Now } \Delta R_2 = \frac{R_4}{R_3} \Delta R_{g1}$$

Output of bridge = $K \Delta R_2$ where K = scale factor of ΔR_2 readout or indicator.

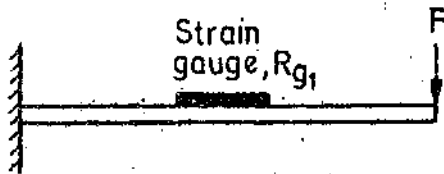

Fig. 29'2. Force acting on a cantilever and measured by using single strain gauge.

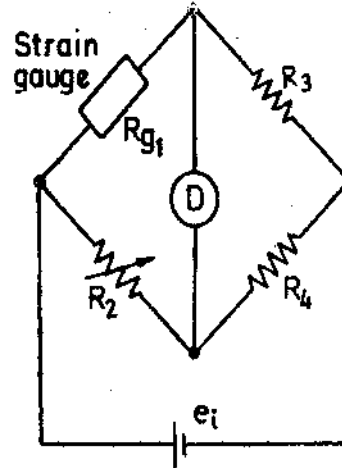

Fig. 29'3. Strain gauge bridge for arrangement of Fig. 29'2.

$$\text{Gauge sensitivity } S_g = \frac{K \Delta R_2}{\epsilon} = \frac{K \Delta R_2}{\Delta R_{g1}/R_{g1}} G_f \quad \dots(29'5)$$

$$= K \frac{R_4}{R_3} \Delta R_{g1} \frac{G_f}{\Delta R_{g1}/R_{g1}} = K \frac{R_4}{R_3} R_{g1} G_f \quad \dots(29'6)$$

When $R_4 = R_3$ and $R_{g1} = R_g$

$$\text{Gauge sensitivity } S_g = K R_g G_f \quad \dots(29'7)$$

29'7. Temperature Compensation

The resistive type strain gauges are sensitive to temperature. Therefore it becomes necessary to account for variations in the strain gauge resistance which occur on account of temperature changes. If changes in resistance due to temperature variations are not accounted for or not compensated, the results would be in error. This is because the resistance of the strain gauge changes both with strain as well as with temperature. Temperature changes act as spurious inputs and cause change in the resistance in two ways :

- (i) the resistance of the wire grid of strain gauge changes with change in temperature,
- and (ii) a change in resistance occurs due to differential expansion existing between the gauge and the test surface to which the strain gauge is bonded. A strain may be caused because of the differential co-efficients of expansion of strain gauge and the surface to which it is bonded to even when there is no load on the test surface.

Temperature effects may be handled by :

- (i) compensation or cancellation,
- and (ii) evaluation as a part of the data reduction problem.

The first method is extensively used for both metallic as well as semi-conductor strain gauges while the second method is used for semi-conductor gauges only.

29'8. Temperature Compensation and Cancellation Techniques

Compensation may be provided by :

- (i) use of adjacent arm balancing or compensating gauge,
- (ii) self-compensation,
- and (iii) use of special external control circuitry.

29'8'1. Adjacent Arm Compensating Gauge

1. Use of Dummy Gauge. One of the ways in which temperature error can be eliminated

by using adjacent arm compensating gauge is to use a **dummy gauge** in the adjacent arm. This arrangement is shown in Fig. 29'4. Gauge 1 is installed on the test specimen (called active gauge) while gauge 3, called a dummy gauge is installed on a like piece of material and is not subjected to any strain. The gauges installed on the test piece and the dummy gauge are at the same temperature. A gauge is called **dummy gauge** in case it is not subjected to any strain. Active gauge is one which is subjected to strain.

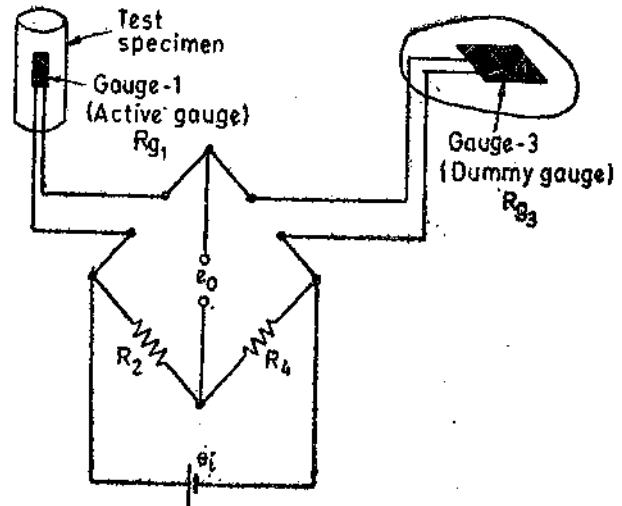

Fig. 9'4. Use of dummy gauge for temperature compensation.

Initially when the bridge is balanced,

$$\frac{R_1}{R_3} = \frac{R_2}{R_4}$$

Supposing a change in temperature occurs, the resistance R_1 and R_3 change by an amount ΔR_1 and ΔR_3 respectively.

Hence for balance :

$$\frac{R_1 + \Delta R_1}{R_3 + \Delta R_3} = \frac{R_2}{R_4}$$

or

$$\frac{R_4}{R_2} (R_1 + \Delta R_1) = (R_3 + \Delta R_3) \quad \text{or} \quad \frac{R_4}{R_2} R_1 + \frac{R_4}{R_2} \Delta R_1 = R_3 + \Delta R_3$$

But

$$\frac{R_4}{R_2} R_1 = R_3 \quad \therefore \frac{R_4}{R_2} \Delta R_1 = \Delta R_3$$

Suppose $R_4 = R_2$. This requires that $\Delta R_1 = \Delta R_3$.

It means that for the bridge to remain insensitive to variations in temperature the gauges R_1 and R_3 should have their resistances change by equal amount when subjected to variations in temperature. Therefore the active gauge R_1 and the dummy gauge R_3 should be identical.

The use of dummy gauge for temperature compensation is simple and effective and should be employed whenever possible.

2. Use of two Active Gauges in Adjacent Arms. In certain applications, where equal and opposite strains are known to exist, it is possible to attach two similar gauges in such a way that one gauge experiences a positive strain and the other a negative strain. Thus instead of having an arrangement wherein one gauge acts as the active gauge and the other as the dummy gauge, we have now an arrangement wherein both the gauges are active gauges.

Fig. 29'5 shows the two gauges mounted on a cantilever. The gauge R_{g1} is on top of the cantilever and hence experiences tension or a positive strain. The R_{g3} is at the bottom surface of the cantilever and hence experiences a compression or a negative strain.

The bridge arrangement for the two gauges is shown in Fig. 29'6. There are two active gauges in the 4 arm bridge and hence it is called a **Half Bridge**.

The temperature effects are cancelled out by having $R_2 = R_3$ and using two identical gauges in the opposite arms of the bridge.

Suppose $R_{g1} = R_{g3} = R_2 = R_4 = R$.

When no strain is applied both points b and d are at the same potential, $e_1/2$ and the value of output voltage $e_0 = 0$.

When the arrangement shown in Fig. 29'5 is subjected to strain, the resistance of gauge 1 increases and that of gauges R_{g3} decreases.

Resistance of gauge R_{g1} when strained is $R(1 + \Delta R/R)$

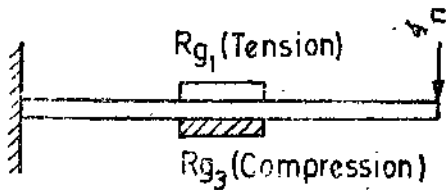

Fig. 29'5. Two gauges used for measurement of strain.

Resistance of gauge R_{g3} when strained is $R(1 - \Delta R/R)$
 Now $R_2 = R_4 = R \therefore$ Potential of point d is $= e_i/2$

\therefore Potential of point $b = \frac{R(1 + \Delta R/R)}{R(1 + \Delta R/R) + R(1 - \Delta R/R)} \times e_i = \frac{1 + \Delta R/R}{2} e_i$

\therefore Change in output voltage when strain is applied is :

$$\Delta e_0 = \frac{1 + \Delta R/R}{2} e_i - \frac{e_i}{2} = \frac{\Delta R/R}{2} e_i = \frac{G_f \epsilon}{2} e_i \quad \dots(29'8)$$

Thus the output voltage from a half bridge is twice that from a quarter bridge and therefore the sensitivity is doubled. In addition, the temperature effects are cancelled. The gauge, sensitivity of a half bridge is :

$$S_G = 2KR_f G_f \quad \dots (29'9)$$

3. Use of Four Active Gauges. Fig. 29'7 shows a cantilever using 4 strain gauges for the measurement of strain. All the four gauges are similar and have equal resistances when strained i.e. $R_{g1} = R_{g2} = R_{g3} = R_{g4} = R$

These gauges are connected in the arms of a Wheatstone bridge as shown in Fig. 29'8. Since the bridge has 4 active gauges with one gauge in each of the four arms, it is called a Full Bridge.

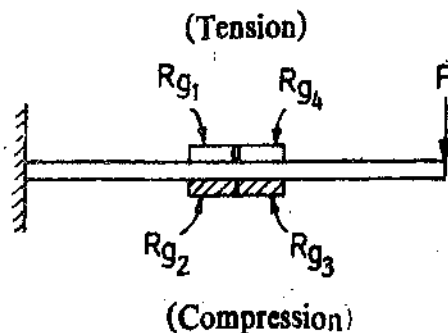

Fig. 29'7. Use of four strain gauges for measurement of strain.

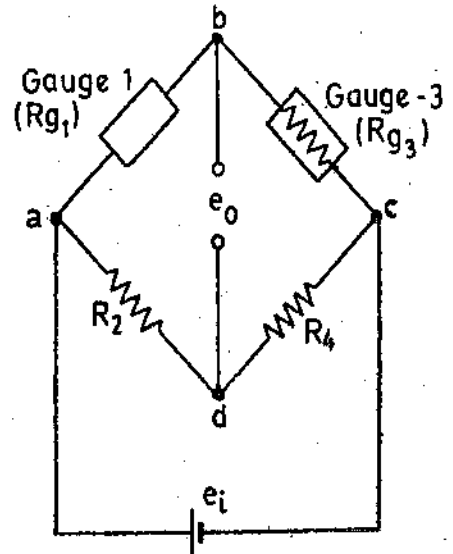

Fig. 29'6. Adjacent arm compensation using two active gauges.

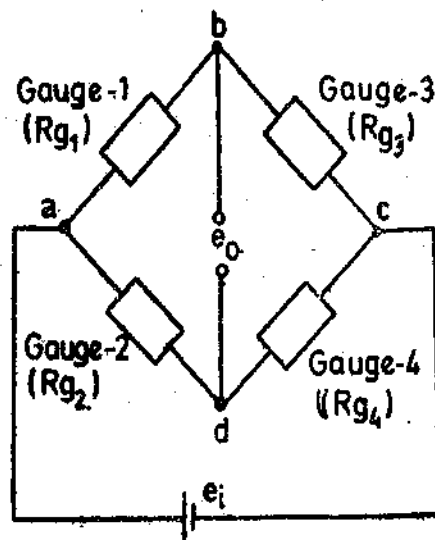

Fig. 29'8. Bridge circuit for measurement of strain using four active gauges.

When no strain is applied, the potentials of points *b* and *d* are both equal to $e_i/2$ and hence the output voltage $e_0=0$.

When strained, the resistance of various gauges are :

For R_{e1} and R_{e4} : $R(1 + \Delta R/R)$ and for R_{e2} and R_{e3} : $R(1 - \Delta R/R)$

$$\text{Potential of } b \text{ when strain is applied} = \frac{R(1 + \Delta R/R)}{R(1 + \Delta R/R) + R(1 - \Delta R/R)} e_i = \frac{1 + \Delta R/R}{2} e_i$$

$$\text{Potential of } d \text{ when strain is applied} = \frac{R(1 - \Delta R/R)}{R(1 - \Delta R/R) + R(1 + \Delta R/R)} e_i = \frac{1 - \Delta R/R}{2} e_i$$

$$\text{Therefore change in output voltage } \Delta e_0 = \frac{1 + \Delta R/R}{2} e_i - \frac{1 - \Delta R/R}{2} e_i = (\Delta R/R) e_i = G_f \epsilon e_i \quad \dots(29'10)$$

Four active-active-arm bridges are extensively used when strain gauges are used as secondary transducers to give maximum sensitivity combined with full temperature compensation. The effect of increasing the number of active gauges is the same if a low impedance detector is used.

4. Poisson's Method. This method of temperature compensation utilises two active gauges R_{e1} and R_{e3} which are bonded at right angles to the structural member as shown in Fig. 29'9 (a).

Measuring gauge is in tension, but gauge R_{e3} reduces in length depending upon the Poisson's ratio of the material. Poisson's gauge is connected, in the adjacent arm of the bridge as shown in Fig. 29'9 (b). The advantage of Poisson's method is that in addition to temperature compensation, the output of the bridge is increased by a factor of $(1 + \nu)$ as compared to a bridge using a single active gauge. The bridge sensitivity is increased by a factor $(1 + \nu)$ accordingly.

$$\text{Change in output voltage when strain is applied } \Delta e_0 = (1 + \nu) \frac{G_f \epsilon}{4} \quad \dots(29'11)$$

Practical Strain Gauge Bridge. A strain gauge bridge may be rigged up by the user or may be purchased as a 'package' which is built up as a unit and only requires connections to the active strain gauge and to a source of power supply. The "package" consists of an amplifier and also other signal conditioning equipment for amplification and monitoring of the output of the strain gauge bridge.

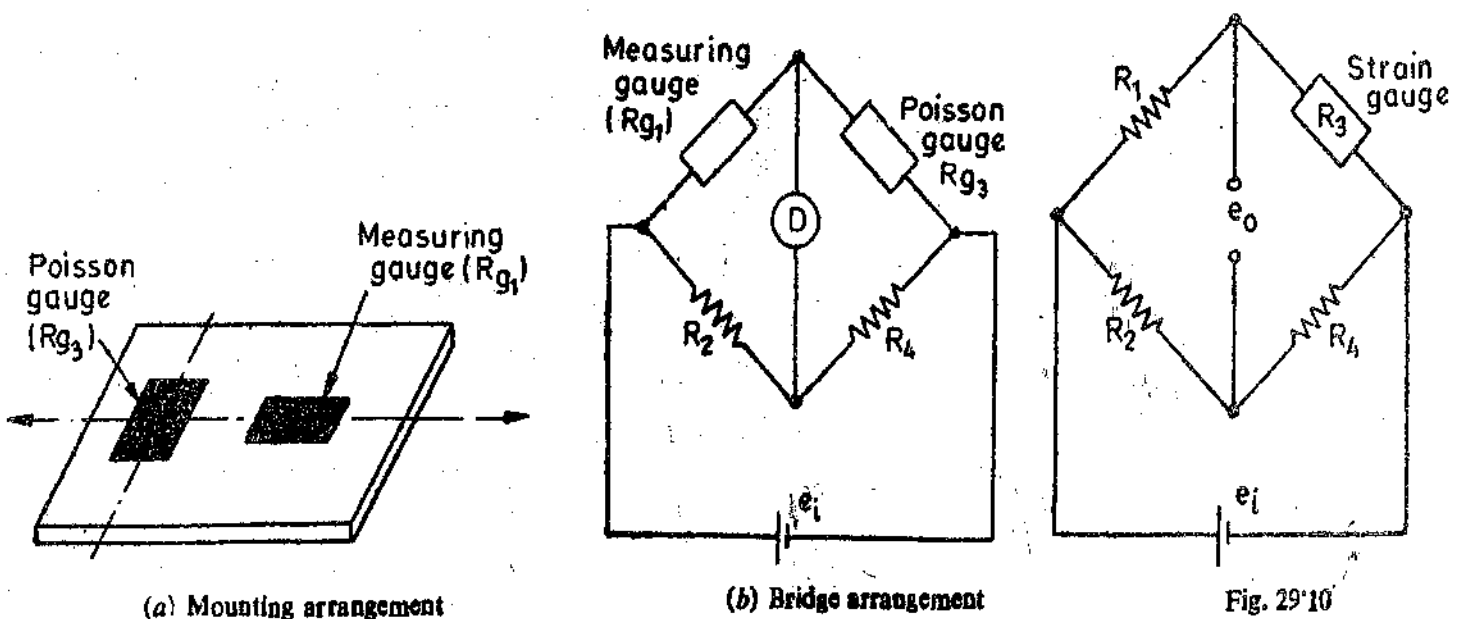

Fig. 29'9 Use of Poisson's gauge

Example 29.4. A strain gauge bridge is shown in Fig. 29.10.

It has two fixed resistors R_1 and R_2 of 120Ω each. The strain gauge is represented by resistance R_3 . The variable resistance R_4 is 120.00Ω at zero strain and has a value of 120.63Ω with strain ϵ . The gauge factor is 2.04. Determine the strain in the beam at the point where the strain gauge is attached.

Solution. Change in value of resistance when strain is applied :

$$\Delta R_4 = 120.63 - 120 = 0.63 \Omega.$$

$$\therefore \text{Change in resistance of gauge when strained : } \Delta R_3 = \frac{R_1}{R_2} (\Delta R_4) = \frac{120}{120} \times 0.63 = 0.63 \Omega.$$

$$\text{Now } \frac{\Delta R_3}{R_3} = G_f \epsilon$$

$$\therefore \text{Strain } \epsilon = \frac{\Delta R_3}{R_3} \times \frac{1}{G_f} = \frac{0.63}{120} \times \frac{1}{2.04} = 2.57 \times 10^{-3} \text{ m}$$

Example 29.5. A strain gauge bridge comprises of two fixed resistors each of value 120Ω , one active gauge, and an unstrained temperature compensation gauge. The two gauges are of unstrained resistance 120Ω and gauge factor 2.2. Find the bridge output voltage (with output open circuited) for a supply voltage of 3 V, when the active gauge is subjected to 600 microstrain.

Solution. The bridge has equal arms when there is no strain. It has only one active gauge. Therefore, output voltage is :

$$\Delta e_0 = \frac{G_f \epsilon}{4} e_i = \frac{2.2 \times 600 \times 10^{-6} \times 3}{4} = 0.99 \times 10^{-3} \text{ V} = 0.99 \text{ mV}.$$

Example 29.6. A single strain gauge is mounted to measure the axial strain in a simple tensile member. If the recorded strain is 380 microstrain, what is the axial stress :

(i) if the member is of steel ? (ii) if the member is of aluminium ?

The modulus of elasticity of steel is 200 GN/m^2 and that of aluminium is 70 GN/m^2 .

Solution. Stress $s = \epsilon E$ where $\epsilon =$ strain, and $E =$ modulus of elasticity.

$$(i) \text{ Stress in steel } s = 380 \times 10^{-6} \times 200 \times 10^9 = 76 \times 10^6 \text{ N/m}^2 = 76 \text{ MN/m}^2.$$

$$(ii) \text{ Stress in aluminium } s = 380 \times 10^{-6} \times 70 \times 10^9 = 26.6 \times 10^6 \text{ N/m}^2 = 26.6 \text{ MN/m}^2$$

Example 29.7. A single electrical resistance strain gauge of resistance 120Ω and having a gauge factor of 2 is bonded to steel having an elastic limit stress of 400 MN/m^2 and modulus of elasticity 200 GN/m^2 . Calculate the change in resistance

(a) due to a change in stress equal to 1/10 of the elastic range ; and (b) due to a change of temperature of 20°C , if the material is advance alloy.

The resistance temperature co-efficient of advance alloy is $20 \times 10^{-6}/^\circ\text{C}$.

(b) Calculate the strain due to differential expansion of the gauge metal and steel if, co-efficient of linear expansion of steel is $12 \times 10^{-6}/^\circ\text{C}$ and that of advance alloy is $16 \times 10^{-6}/^\circ\text{C}$.

Calculate also the change in resistance. Comment upon the results.

Solution. (a) Change of stress $s = 400 \times 10^{-6} \times 1/10 = 40 \times 10^6 \text{ N/m}^2 = 40 \text{ MN/m}^2$.

$$\text{Change of strain } \epsilon = \frac{s}{E} = \frac{40 \times 10^6}{200 \times 10^9} = 200 \times 10^{-6}$$

$$\therefore \text{Change in resistance } \Delta R = G_f \epsilon R = 2 \times 200 \times 10^{-6} \times 120 = 0.048 \Omega.$$

(b) Change in resistance due to change in temperature

$$= \alpha \Delta \theta R = 20 \times 10^{-6} \times (20) \times 120 = 0.048 \Omega.$$

The strain due to differential expansion of the gauge metal and steel is :

$$\epsilon = (12-16) \times 10^{-6} \times 20 = -80 \times 10^{-6} = -80 \text{ microstrain.}$$

$$\therefore \Delta R = G_f \epsilon R = 2 \times 80 \times 10^{-6} \times 120 = -0.019 \Omega$$

Comments. The change of resistance due to change in temperature is of the same order as that due change in resistance caused by application of strain. If the temperature effects are not compensated for, they will lead to extremely large errors in the measurement of strain. The measurement in the fact does not have any meaning.

It is seen that change due to differential expansion partly offsets the change due to co-efficient of resistivity in the example. The effect may become additive instead of subtractive in certain combinations of gauge metal and the metal used for mounting.

Example. 29.8. The electrical strain gauges are bonded to a Duralumin cantilever (Fig. 29.5) and connected into a bridge circuit as shown in Fig. 29.6. Each gauge has a resistance of 100 Ω and a gauge factor of 2.1. The input voltage is 4 V. The stress is 200 M/N², calculate (a) the change in the value of resistances R_4 to restore balance.

(b) the output voltage if the detector has a resistance of 10 k Ω .

(c) the current through the detector if its resistance is 400 Ω .

(d) Current through the strain gauges.

The modulus of elasticity for Duralumin is 70 GN/m².

Solution. One of the gauges is subjected to tensile stress and the other to compressive stress. The change in the value of resistance R_4 to restore balance is :

$$\Delta R_4 = 2 G_f \epsilon k = 2 \times 2.1 \times \frac{200 \times 10^6}{70 \times 10^9} \times 100 = 1.2 \Omega.$$

(b) Open circuit voltage across the bridge for two active strain gauges is :

$$e_0 = \frac{G_f \epsilon}{2} e_i = \frac{2.1 \times 200 \times 10^6}{70 \times 10^9} \times \frac{4}{2} = 0.012 \text{ V} = 12 \text{ mV.}$$

Output voltage when the meter is connected across the output terminals is :

$$e_{0L} = \frac{1}{1 + R_0/R_m} \times e_0 = \frac{1}{1 + 100/10 \times 10^3} \times 0.012 \text{ V} = 11.9 \text{ mV.}$$

(c) When a meter of 400 Ω is connected across the bridge output terminals, the output voltage is :

$$e_{0L} = \frac{1}{1 + 100/400} \times 0.012 \text{ V} = 9.6 \text{ mV.}$$

$$\therefore \text{Meter current } I_m = \frac{e_{0L}}{R_m} = \frac{9.6 \times 10^{-3}}{400} = 24 \times 10^{-6} \text{ A} = 24 \mu\text{A}$$

$$(d) \text{ Current through strain gauges} = \frac{e_i}{2R} = \frac{4}{2 \times 100} = 0.02 \text{ A} = 20 \text{ mA.}$$

Example 29.9. In order to measure strain in a cantilever beam, a single strain gauge of resistance 1 k Ω , and gauge factor 2 and a temperature co-efficient $10 \times 10^{-6}/^\circ\text{C}$ is mounted on the beam and connected in one arm of a bridge circuit. The other three arms of the bridge have a resistance of 100 Ω each. The bridge detector resistance is 100 Ω and its sensitivity is 10 mm/ μA .

- (a) Calculate the detector deflection for 0.1 percent strain.
 (b) Calculate the change in effective strain indicated when the room temperature increases by 10°C.

Solution. (a) Change in strain $\epsilon = 0.1\% = 0.001$.

Change in resistance $\Delta R = 0.001 \times 2 \times 1000 = 2 \Omega$.

\therefore Resistance of gauge $= 1000 + 2 = 1002 \Omega$.

Open circuit voltage of Thevenin generator

$$e_0 = \left(\frac{1002}{1000 + 1002} - \frac{100}{100 + 100} \right) \times 10 \text{ V} = 5 \text{ mV.}$$

Resistance of Thevenin generator $R_0 = \frac{1002 \times 1000}{2002} + \frac{100 \times 100}{200} = 550.5 \Omega$.

\therefore Current through detector $I_m = \frac{5 \times 10^{-3}}{550.5 + 100} \text{ A} = 7.7 \mu\text{A}$.

and deflection of galvanometer $= 7.7 \times 10 = 77 \text{ mm}$.

(b) Change in resistance due to change in temperature $\Delta R = 10 \times 10^{-6} \times 1000 \times 10 = 0.1 \Omega$.

The equivalent strain $\epsilon = \frac{\Delta R}{G_f R} = \frac{0.1}{2 \times 1000} = 50 \times 10^{-6} = 50 \text{ microstrain}$

Example 29.10. A strain gauge is used for measurement of dynamic strain as shown in Fig. 29.10. The strain gauge has a resistance of 1 k Ω when unstrained. A resistance of 1 k Ω is connected in the arm adjacent to strain gauge. The resistances of other two arms are 10 k Ω each.

The strain gauge is bonded to structural member and is subjected to a sinusoidal time varying strain. As a result of this strain, the resistance value of strain gauge alternates between extremes of 999 Ω and 1001 Ω . The bridge output is connected to an amplifier. Determine the equivalent circuit. The supply voltage is 10 V.

Solution. Open circuit voltage of bridge under maximum tension :

$$= \left[\frac{1001}{1001 + 1000} + \frac{10,000}{10,000 + 10,000} \right] \times 10 \text{ V} = 2.5 \text{ mV}$$

Open circuit voltage under maximum compression :

$$= \left[\frac{999}{999 + 1000} + \frac{10,000}{10,000 + 10,000} \right] \times 10 \text{ V} = -2.5 \text{ mV}$$

Therefore the output voltage alternates with an amplitude of 2.5 mV.

Thevenin source resistance

$$R_0 = \frac{1000 \times 1000}{2000} + \frac{10000 \times 10,000}{20,000} = 5500 \Omega.$$

The equivalent circuit is shown in Fig.

29.11.

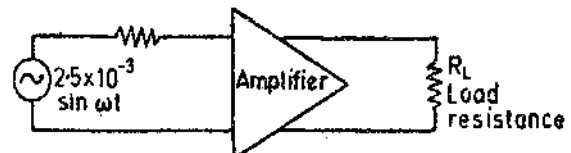

Fig. 29.11

Note : For More Solved and Unsolved Examples on Strain Gauges See pages 767, 772, 823 and 824.

29.9. Strain Gauge Calibration

A theoretical objection to the use of strain gauges is that, in most applications, it is impossible to check the accuracy of the readings obtained from them. Once the strain gauge is bonded in its measuring position, it cannot be removed or transferred and subjected to a known strain for calibration. Strain gauges are often used in applications where no other form of strain measurement

is possible. Since no check on performance can be made, the value of the gauge factor as specified by the manufacturer has to be relied. However, this leads to errors because the value of gauge factor is specified with certain tolerance limits and hence each gauge should be individually calibrated.

Simple strain gauge bridges usually employ readout systems having scales marked in arbitrary units. The basic motive of practical calibration of strain gauges is to establish a relationship between arbitrary units and the measured strain. In fact, calibration of strain gauges involves making necessary adjustments to obtain correct scale reading.

The technique employed is to produce a known change in the resistance of one of the bridge arms to simulate a particular value of strain. The value of the change in resistance required for this purpose may be calculated if the unstrained resistance of the gauge, and the gauge factor, are known.

The procedure for calibration of strain gauges, involves a known change in the value of the resistance of the strain gauge by shunting it with a high value of resistance and then measuring the output corresponding to the known change of resistance. This is shown in Fig. 29'12. A shunt resistance R_{sh} is used, the resistance of the gauge being R_g .

Resistance of arm 1 of bridge before switch S is closed = R_g

Resistance of arm 1 of bridge after switch S is closed

$$= \text{Resistance of parallel combination of } R_g \text{ and } R_{sh}$$

$$= \frac{R_g R_{sh}}{R_g + R_{sh}}$$

∴ The change in resistance of arm 1 resulting from introduction of shunt resistance R_{sh} is :

$$\Delta R = R_g - \frac{R_g R_{sh}}{R_g + R_{sh}} = \frac{R_g^2}{R_g + R_{sh}} \quad \dots(29'11)$$

Equivalent strain $\epsilon_s = \frac{1}{G_f} \cdot \frac{\Delta R}{R_g}$

$$= \frac{1}{G_f} \cdot \frac{1}{R_g} \cdot \frac{R_g^2}{R_g + R_{sh}} = \frac{R_g}{G_f(R_g + R_{sh})} \quad \dots(29'12)$$

Shunt resistance $R_{sh} = \frac{R_g(1 - G_f \epsilon_s)}{G_f \epsilon_s} \quad \dots(29'13)$

In practice $G_f \epsilon_s \ll 1$, and therefore the term $G_f \epsilon_s$ in the numerator of Eqn. 29'13 can be neglected without introducing any significant error.

$$\therefore R_{sh} \approx \frac{R_g}{G_f \epsilon_s} \quad \dots(29'14)$$

The value of effective strain ϵ_s may be determined, exactly from Eqn. 29'12 or 29'13 or nearly exactly from Eqn. 29'14. If a linear relationship between the readout (output indicator system) and strain is assumed, only one value of R_{sh} is required for the calibration. This value of R_{sh} should be so chosen that the readout (output indicator) gives its full scale deflection.

The calibration of bridges using more than one active strain gauge may be done in the same manner. Suppose there are n active strain gauge elements in the bridge, then the strain represented by a given value of R_{sh} is $1/n$ (approximataly) of the strain given by Eqn. 29'12.

$$\therefore \text{Effective strain } \epsilon_s = \frac{R_g}{n G_f (R_g + R_{sh})} \quad \dots(29'15)$$

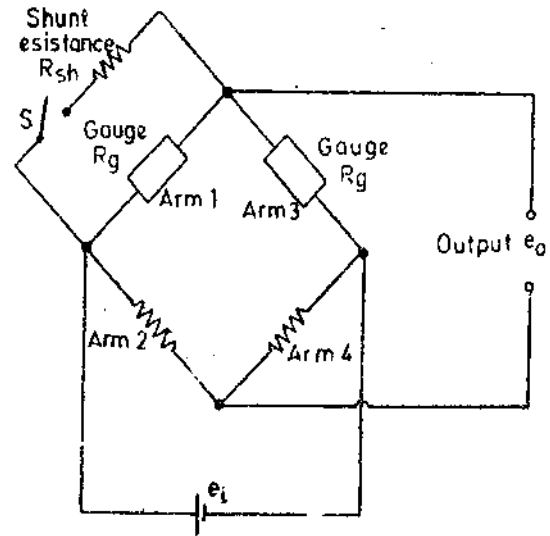

Fig. 29'12. Calibration of strain gauges.

Example 29.11. A strain gauge bridge comprises of two fixed 120Ω resistors, and one is an active gauge and one unstrained temperature compensating gauge. The two gauges have an unstrained resistance value of 120Ω each. The gauge factor is 2.2. Find the strain which would be represented by $100 \text{ k}\Omega$ calibration resistance shunting one arm of bridge.

Solution.

From Eqn. 29.12, the effective strain represented by the arrangement is :

$$\epsilon_e = \frac{R_g}{G_f(R_g + R_{sh})} = \frac{120}{2.2(120 + 100 \times 10^3)} = 0.545 \times 10^{-3} = 545 \text{ microstrain.}$$

Example 29.12. Four strain gauges are mounted on a simple flat tensile specimen arranged for complete temperature compensation and maximum sensitivity when connected in a four arm bridge circuit. An $800,000 \Omega$ calibration resistor is shunted across one of the strain gauges. Gauge resistances are each 118Ω and gauge factors are 1.22.

If the strain gauge readout is 150 divisions when the calibration switch is closed and 240 divisions when the load is applied, what is the axial strain in the specimen.

Solution.

The bridge has four active elements.

$$\therefore \text{Effective strain } \epsilon_e = \frac{R_g}{n G_f(R_g + R_{sh})} = \frac{118}{4 \times 1.22(118 + 800,000)} = 48.1 \times 10^{-6}$$

When the calibration switch is closed, the readout gives a reading of 150 divisions.

$$\therefore 1 \text{ division} = \frac{48.1}{150} \times 10^{-6} = 0.321 \times 10^{-6}$$

When the strain gauges arrangement is loaded, the strain is :

$$\epsilon = 0.321 \times 10^{-6} \times 240 = 77 \times 10^{-6} = 77 \text{ microstrain.}$$

29.10. Load Cells

Load cells utilize an elastic member as the primary transducer and strain gauges as secondary transducers as explained in Art. 25.2 page 746. Strain gauges may be attached to any elastic member (as shown in Fig. 29.13) on which there exists a suitable plane area to accommodate them. This arrangement may then be used to measure loads applied to deform or deflect the member, provided that the resultant strain is large enough to produce detectable outputs. When the strain gauge-elastic member combination is used for weighing it is called a load cell.

29.11. Tensile-Compressive Cell

Fig. 29.13 shows a tensile-compressive cell which is a cylinder. This arrangement uses four strain gauges each mounted at 90° to each other. The bridge circuit is also shown. Two of strain gauges experience tensile stress while the other two are subjected to compressive stress.

The output of a bridge with equal arms and using two strain gauges mounted 90° to each other is :

$$\Delta e_0 = (1 + \nu) \left[\frac{\Delta R_1/R}{4 + 2(\Delta R_1/R)} \right] \epsilon_t$$

(See page 969 for Poisson's compensation)

In the present case, there are two sets of gauges mounted 90° to each other, with one set experiencing tensile stress while the other a compressive stress.

$$\therefore \text{Output voltage of Wheatstone bridge : } \Delta e_0 = 2(1 + \nu) \left[\frac{\Delta R_1/R}{4 + 2(\Delta R_1/R)} \right] \epsilon_t \quad \dots(29.16)$$

The above relationship is clear from the following explanation :

In the case of a cylinder, an axial compressive load causes a negative strain in the vertical gauges, and a positive strain in the circumferential gauges. The two strains are not equal in this case. These two strains are related to each other by a factor, ν , called the Poisson's ratio. Since the value of the strain is of no interest, the objective is to produce a force transducer. This force transducer is calibrated empirically. In case all the gauges are similar, temperature compensation is obtained as all the gauges contribute equally to unbalance the bridge.

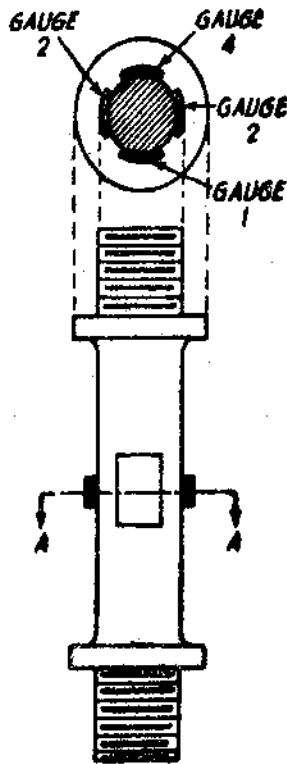

(a) Load cell

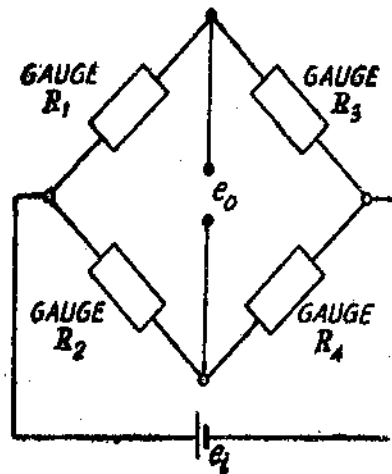

(b) Load cell strain gauge bridge

Fig. 29'13. Tension compression resistance strain gauge cell.

Compression cells of this type have been used with a capacity of 300 MN.

Unbonded strain gauge transducers are frequently used for force measurement, particularly if high sensitivity is required. Highest sensitivity is obtained when the gauge itself performs the function of elastic member, *i.e.*, all the input force is used for producing strain in the gauge.

Example 29'13. A load cell consists of a solid cylinder of steel 40 mm in diameter with four strain gauges bonded to it and connected into the four arms of a voltage sensitive bridge. The gauges are mounted to have Poisson's arrangement.

If the gauges are each of 100 Ω resistance and the gauge factor 2.1, the bridge excitation voltage 6 V, determine the sensitivity of the cell in V/kN. Modulus of elasticity for steel is 200 GN/m² and the Poisson's ratio is 0.29.

Solution. Suppose a load of 1 kN is applied to the load cell.

$$\text{Stress } s = \frac{1 \times 10^3}{(\pi/4)(40 \times 10^{-3})^2} = 0.796 \times 10^6 \text{ N/m}^2.$$

$$\text{Strain } \epsilon = \frac{s}{E} = \frac{0.796 \times 10^6}{200 \times 10^9} = 3.98 \times 10^{-6}.$$

$$\therefore \frac{\Delta R}{R} = \epsilon G_f = 3.98 \times 10^{-6} \times 2.1 = 8.36 \times 10^{-6}$$

From Eqn. 29'16, the voltage output of the bridge is :

$$\Delta e_0 = 2(1 + \nu) \left[\frac{(\Delta R_1/R)}{4 + 2(\Delta R_1/R)} \right] e_1 = 2(1 + 0.29) \left[\frac{8.36 \times 10^{-6}}{4 + 2 \times 8.36 \times 10^{-6}} \right] \times 6$$

$$= 0.324 \times 10^{-6} \text{ V} = 0.324 \text{ } \mu\text{V}.$$

Hence, the sensitivity is $0.324 \text{ } \mu\text{V/kN}$.

29.12. Rosettes

In a practical problem, an element may be subjected to stresses in any direction and hence it is not possible to locate the direction of principal stress. Thus it is not practically possible to orient the strain gauge along the direction of principal stress. Therefore there is a necessity to evolve a strain gauge measurement system which measures the values of principal strains and stresses without actually knowing their directions. The solution to the problem lies in using three strain gauges oriented in different directions to form a unit called a Rosette.

Rosettes are of many types. Fig. 25.18 on page 771 shows different types of strain gauges and rosettes.

The principal strain or stress direction and magnitude can be determined from rosette readings by suitable calculations.

29.13. Strain Gauge Circuitry

There are many strain gauge instrumentation circuits available commercially. The type instrumentation system depends upon the following considerations :

- (i) whether static or dynamic strains have to be measured,
- (ii) whether an analog or a digital readout is desired,
- (iii) whether output is to be displayed on a recorder for instantaneous reading or for permanent record,
- (iv) whether a single channel is required or multichannel measurement is necessary.

Depending upon the requirement a suitable instrumentation may be selected.

The most commonly used circuit for strain measurements is a Wheatstone bridge with d.c. excitation. The strain may be measured with the help of a voltmeter connected across the output

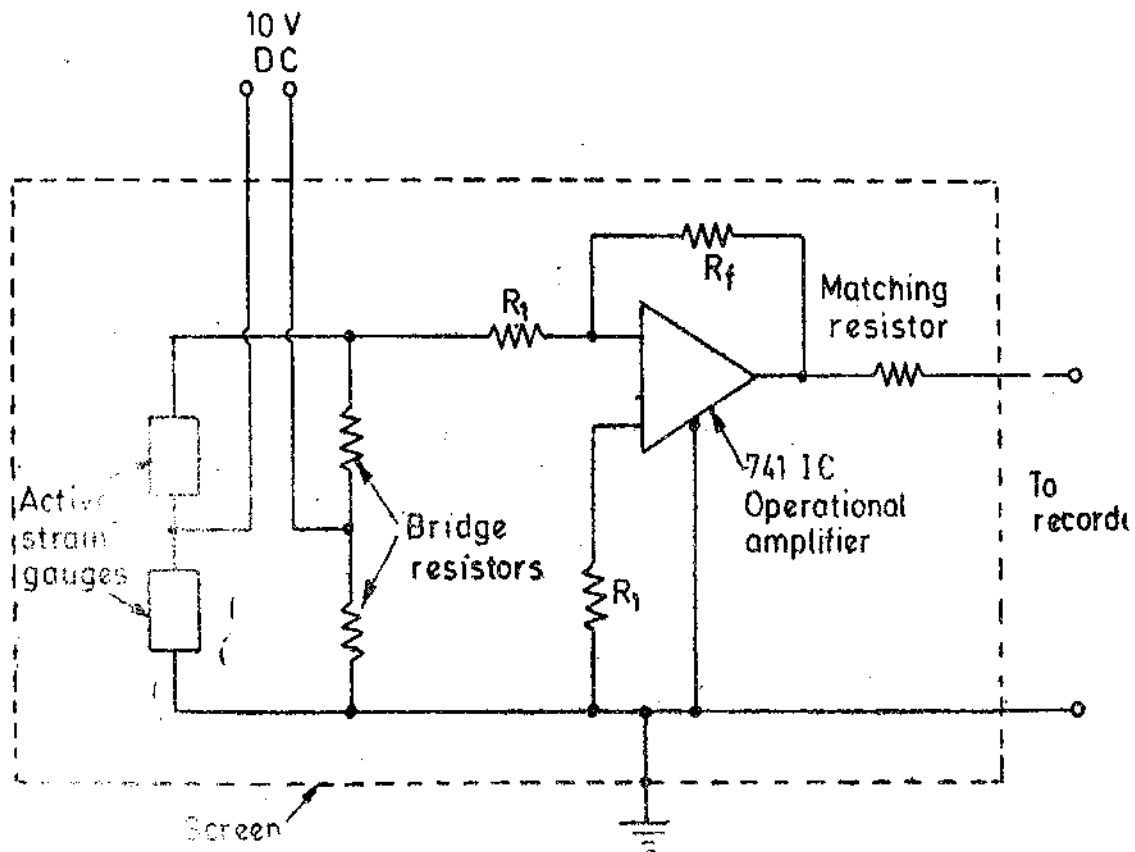

Fig. 29.14. Strain gauge bridge circuit with IC operational amplifier.

terminals. The scale of the voltmeter may be calibrated in terms of strain. The voltmeter may be called a "strain indicator". The voltmeter may be a d.c. analog meter and digital voltmeter. Since the output is low, it may have to be amplified before being fed to the voltmeter. This requires the use of a d.c. amplifier which has inherent problems.

It has been found that by using IC operational amplifiers placed in the proximity of a strain gauge bridge using two active gauges, inexpensive load cells of various sensitivities may be constructed with sufficient output to actuate galvanometric recorders (ultra-violet recorders are normally used). This arrangement is shown in Fig. 29'14. However, this arrangement involves screening and earthing to ensure the removal of power line (50 Hz) pick up.

Fig. 29'15 shows a highly sophisticated system which employs four active strain gauge connected in a bridge circuit.

The galvanometer of the usual bridge circuit is replaced by a self-balancing potentiometer. A low resistance slide wire is connected between R_{G3} and R_{G4} to adjust the bridge so that the self-balancing potentiometer reads zero when no strain is applied.

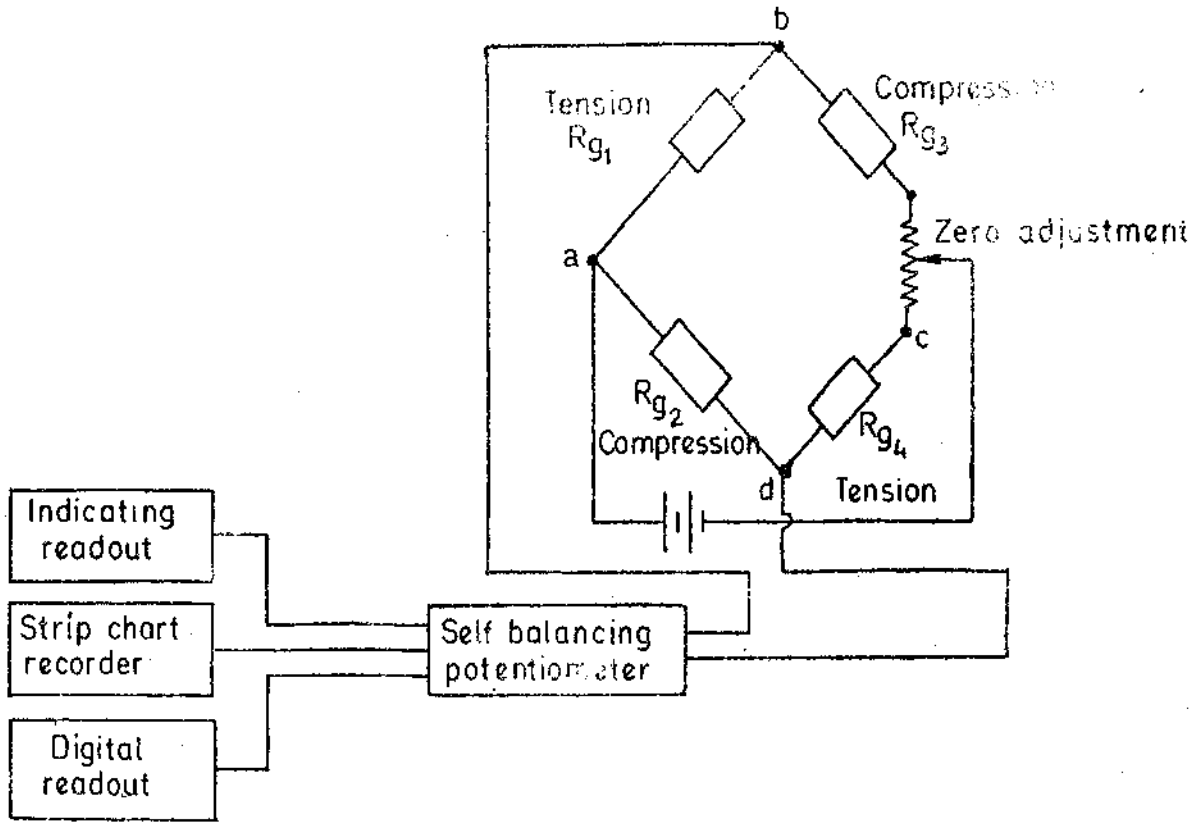

Fig. 29'15 Strain gauge measurement using different types of read out devices.

The output device of a self-balancing potentiometer could be an indicator, a digital voltmeter, a strip chart recorder for recording purposes. The output may also be indicated or recorded by numerous combinations of the above readout systems.

Commercial strain gauge bridges normally use an a.c. power supply and subsequently demodulate and amplify the output so that greater sensitivity could be achieved. The normal excitation frequency is 1000 Hz, providing frequency response up to 100 Hz. Since the normal frequency response is about 10% of the carrier frequency, problems requiring better response will necessitate higher carrier frequencies. Instruments utilizing 20 kHz excitation frequency are commercially available (Fig. 29'16). They usually have their own recording oscillograph with provision for viewing the waveform on an external oscilloscope display.

The output may be fed to a strip chart recorder to record the variations. A galvanometer type recorder provided with mirror arrangement is used with moving photographic paper or film for permanent and reproducible records.

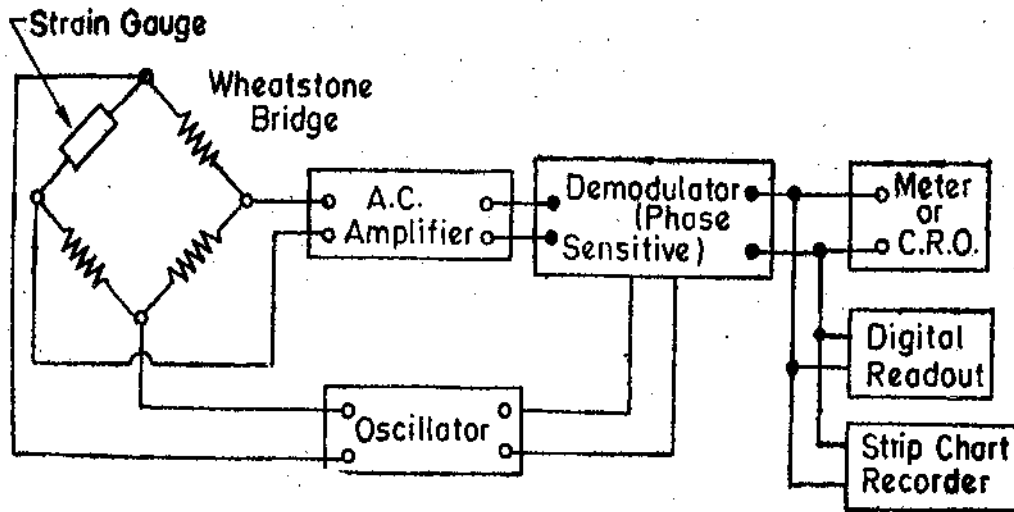

Fig. 29'16. Stain gauge circuitry for dynamic measurement and recording.

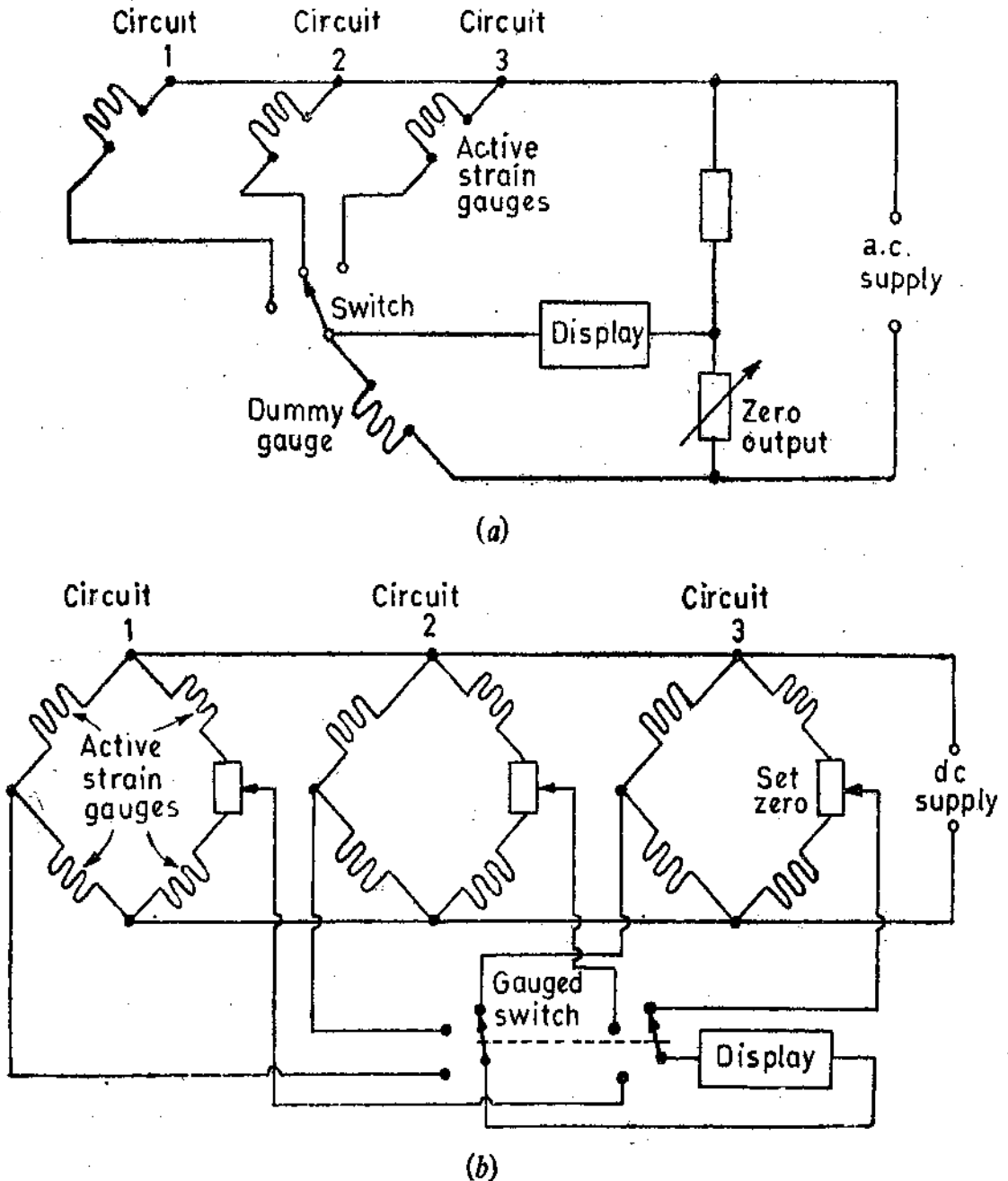

Fig. 29'17. Multipoint arrangements. (a) Single active gauge arrangement ; (b) four active gauge arrangement.

Multipoint Measurements. In many applications of strain gauges, it is desirable to measure strain at more than one point. This necessitates the use of a number of strain gauges which may be arranged so that either they have a bridge circuit and a display device each. Instead an arrangement wherein only one bridge circuit and a single display device are used which are connected to each strain gauge circuit in turn through a switch. The latter method is very much less expensive. However, this method has some disadvantages like introduction of errors due to switch contact resistance, and different zero settings for each strain gauge circuit.

The strain gauge circuits may use one, two or four active strain gauges and suitable arrangements must be developed whereby each of these situations may be incorporated in a multipoint measuring system.

Fig. 29'17 (a) shows a system where there is only one active strain gauge in each circuit while Fig. 29'17 (b) shows an arrangement for four active gauges in each circuit.

29 14 Uses of Strain Gauges. 1. Strain gauges are used extensively for analyzing the dynamic strains in complex structures such as the stress and the strain in bridges, automobiles, roads etc. where the output of the bridge can be recorded with an oscillograph calibrated to read the instantaneous strain or stress.

2. Resistance strain gauges are very useful for measurement of tension, torque, force, stresses in structures. They are particularly useful where a minimum disturbance by the presence of transducer is required as in wind tunnel measurements.

3. Strain gauges are used in load cells and proving rings to measure force by the strain produced. The proving ring is usually made of steel. The strain produced in the load ring is measured with a strain gauge. The strain is a measure of the force applied to the ring.

MEASUREMENT OF PRESSURE

29'15. Introduction

Pressure measurements are one of the most important measurements made in industry. The number of instruments used are by far greater in number than the instruments used for any other type of measurement.

The principles used in the measurement of pressure are also, applied in the measurement of temperature, flow, and liquid levels. Thus it is essential to have complete knowledge of working principles of these instruments.

Pressure is represented as force per unit area. As such it may be considered as a type of stress since stress is also defined as force per unit area. In this section, the term 'pressure' refers to the force per unit area exerted by a fluid on a containing wall. Therefore, the discussion of pressure measurement is limited to fluid systems. The forces that arise as a result of strains in solids are designated as stresses and have been discussed earlier.

29'16. Types of Pressure Measurement Devices

In industrial applications the pressure is usually measured by means of indicating gauges or recorders. These instruments may be mechanical, electro-mechanical, electrical or electronic in operation.

(i) **Mechanical Instruments.** These instruments may be classified into two groups. The first group includes those instruments in which the pressure measurement is made by balancing an unknown force with a known force. The second group includes those employing quantitative deformation of an elastic member for pressure measurement.

(ii) **Electro-Mechanical Instruments.** These instruments usually employ a mechanical means for detecting the pressure and electrical means for indicating or recording the detected pressure.

(iii) **Electronic Instruments.** Electronic pressure measuring instruments normally depend on some physical change that can be detected and indicated or recorded electronically.

In this text, the discussion is limited only to Electro-mechanical and Electronic instruments.

29'17. Measurement of Pressure Using Electrical Transducers as Secondary Transducers. The measurement of force or pressure can be done by converting the applied force or pressure into a

displacement by elastic elements which act as primary transducers. This displacement, which is a function of pressure may be measured by transducers which act as secondary transducers. The output of the secondary transducers is a function of displacement, which in turn is a function of pressure. Mechanical methods have to be used to convert the applied force or pressure into displacement. These devices are called Force Summing Devices.

They possess elasticity, when deformed, the stresses established in the summing device establish equilibrium with the applied pressure. The choice and design of the type of summing element used depends on the magnitude of force or pressure to be measured.

The most commonly used summing devices are :

1. Flat or corrugated diaphragms.
2. Bellows.
3. Circular or twisted Bourdon tube.
4. Straight tube.
5. Single or double mass cantilever suspension.
6. Pivot torque.

Examples of these force summing devices are given in Fig. 29'19. Pressure transducers generally use one of the first four types of force summing members. While mass cantilever suspension and pivot torque types are found in accelerometers and velocity transducers.

29'17'1. Force Summing Devices. Some of the force, summing devices are described below :

1. Diaphragms. The movement of a diaphragm is a convenient way of sensing a pressure differential. The unknown pressure. is applied to one side of the diaphragm whose edge is rigidly fixed and the displacement of the centre of the diaphragm is measured.

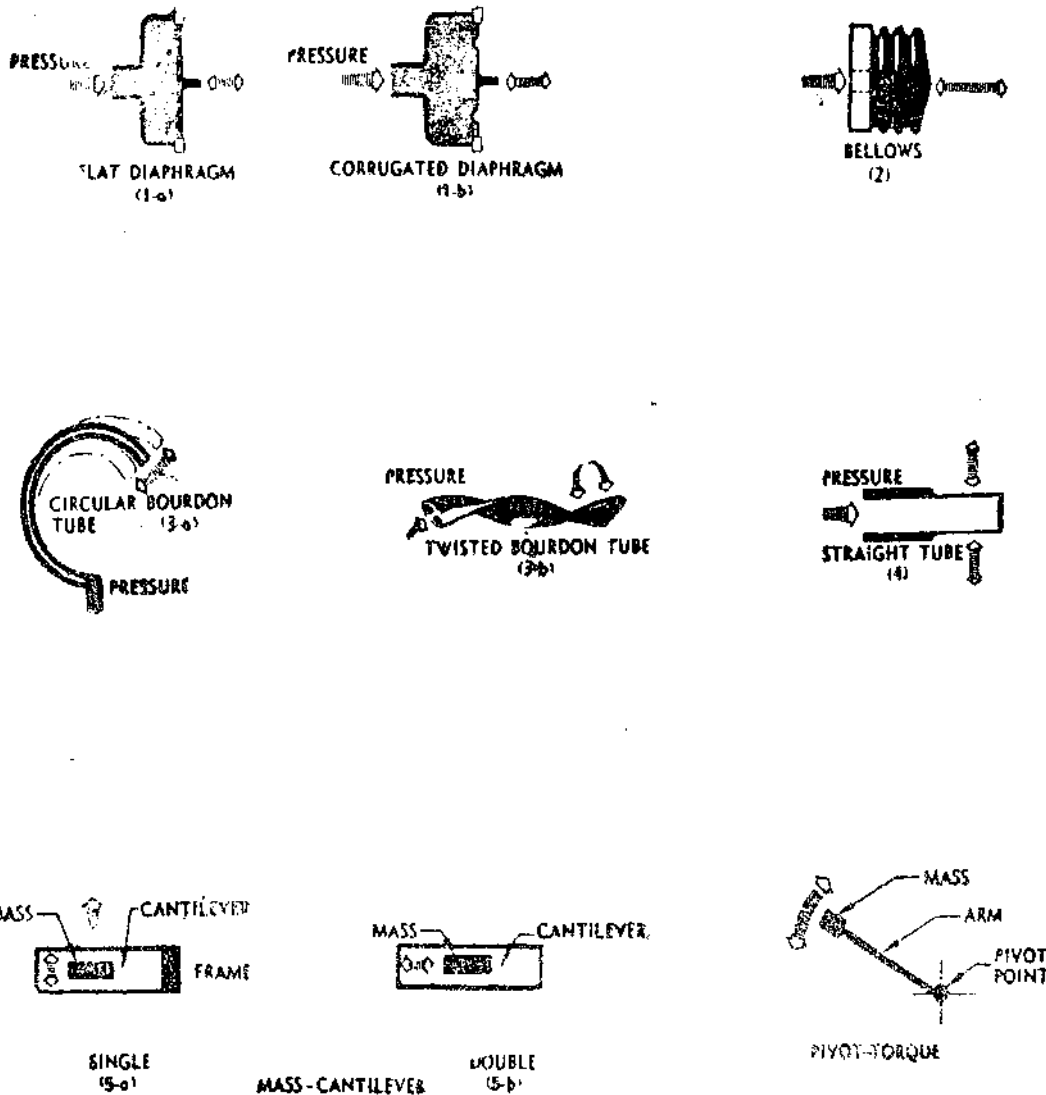

Fig. 29'18. Force summing devices.

There are two types of diaphragms : (i) flat, and (ii) corrugated. Corrugated diaphragms give a larger displacement and can be conveniently combined to form a capsule, two corrugated discs being soldered together at the outer edges. A stack of capsules will give even a greater displacement.

2. **Bellows.** Bellows is a thin walled tube having a corrugated shape. Essentially it is a pressure activated spring. The stiffness (or in other words the displacement for a particular pressure) depends upon the type and thickness of the material used. The most commonly used materials for bellows and other pressure sensing elements are steel, phosphor bronze and beryllium copper.

3. **Bourdon Tube.** It is most widely used force summing (or pressure sensing) element. It consists of a narrow bore tube of elliptical cross-section, sealed at one end. The pressure is applied at the other end which is open and fixed. The tube is formed into an arc of a curve, a flat spiral or a helix. When the pressure is applied, the effect of the forces is to straighten it so that the closed end is displaced.

29'17.2. **Secondary Transducers.** The displacement created by the action of the force summing member is converted into a change of some electrical parameter. The force summing member actuates a transducer which converts the displacement into an output of electrical format. The various transducers used are of the following types :

- (i) Resistive,
- (ii) Inductive.
- (iii) Differential transformers,
- (iv) Capacitive,
- (v) Photo-electric,
- (vi) Piezo-electric,
- (vii) Ionization,
- and (viii) Oscillation.

1. **Resistive Transducers.** The electrical strain gauges attached to a diaphragms shown in Fig. 29'19 may be used for measurement of pressure.

The output of these strain gauges is a function of the local strain, which, in turn, is a function of the diaphragm deflection and the differential pressure. The deflection generally follows a linear variation with differential pressure $P = P_2 - P_1$. (when the deflection is less than one third of the diaphragm thickness.)

One of the disadvantages of the method is the small physical area is required for mounting the strain gauges. Change in resistance of strain gauges on account of application of pressure is calibrated in terms of the differential pressure. Gauges of this type are made in sizes having a lower range of : 100 kN/m^2 to 3 MN/m^2 to an upper range of ; 100 kN/m^2 to 100 MN/m^2 .

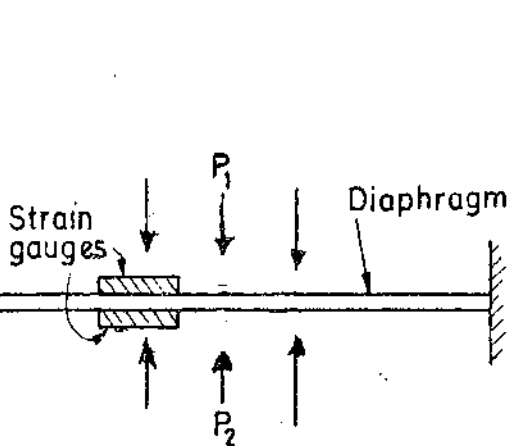

Fig 29'19. Measurement of differential pressure with diaphragm and strain gauges.

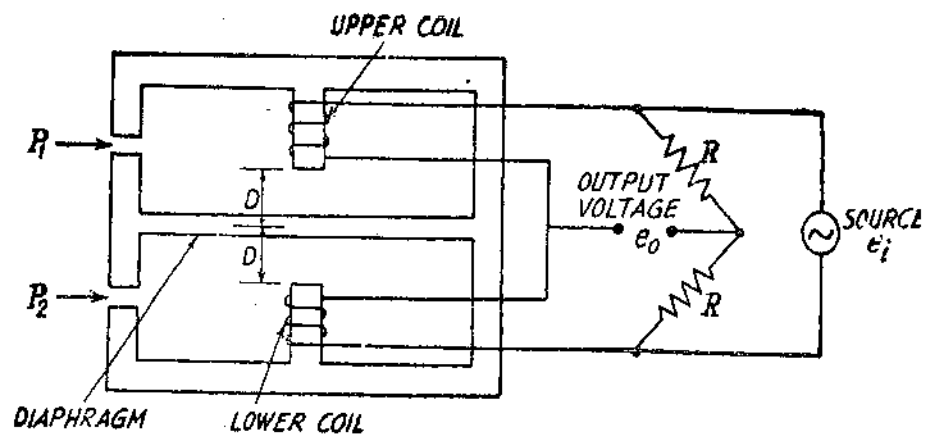

Fig. 29'20. Measurement of pressure with diaphragm element and inductive transducer.

2. **Inductive Transducers.** Inductive transducers have been successfully used as secondary transducers along with a diaphragm for measurement of pressure. Fig. 29'20 shows an arrangement which uses two coils ; an upper and a lower coil which form the two arms of an a.c. bridge. The

coils have equal number of turns. The other two arms of the bridge are formed by two equal resistances each of value R .

The diaphragm is symmetrically placed with respect to the coils and so when $P_1 = P_2$, the reluctances of the paths of magnetic flux for both the coils are equal and hence the inductances of the coils are equal.

Now initial self-inductance $= N^2/R_0$ where N = number of turns, and R_0 = initial reluctance of flux path. Under this condition the bridge is balanced and the output, e_0 , of the bridge is zero.

Suppose P_2 is greater than P_1 and therefore the differential pressure, $P = P_2 - P_1$, deflects the diaphragm upwards through a distance d . For small displacements of diaphragm, the reluctance of the flux path of the upper coil is $R_1 = R_0 + K(D-d)$ and that of the lower coil is $R_2 = R_0 + K(D+d)$.

Hence, the inductance of the upper coil $L_1 = N^2/R_1 = N^2/[R_0 + K(D-d)]$ and that of lower coil is $L_2 = N^2/R_2 = N^2/[R_0 + K(D+d)]$.

The bridge becomes unbalanced and the approximate value of output voltage is given by :

$$e_0 = \left[\frac{1}{2} - \frac{L_2}{L_1 + L_2} \right] e_i$$

$$= \left\{ \frac{1}{2} - \frac{N^2/[R_0 + K(D+d)]}{N^2/[R_0 + K(D-d)] + N^2/[R_0 + K(D+d)]} \right\} \times e_i = \frac{Kd \times e_i}{2(R_0 + KD)} \quad \dots (29.17)$$

Since K , R_0 , D and e_i are constant, the output voltage is directly proportional to displacement d , of the diaphragm. Displacement d , is directly proportional to differential pressure $P = P_2 - P_1$. Hence the output voltage e_0 may be calibrated in terms of the differential pressure P .

It is seen that there exists a linear relationship between output voltage e_0 and the differential pressure for small values of deflection d .

It is possible to determine whether $P_2 > P_1$ or $P_1 > P_2$ with reference to the phase of output voltage, e_0 , with respect to source voltage e_i .

Standard laboratory equipment, such as a VTVM, a TVM, an oscilloscope, as well as recorders may be used for display and recording of the output. The gauge may be used for pressures ranging from 0–5 kN/m² to 0–100 kN/m².

3. LVDT. The LVDT is used as a secondary transducer for measurement of pressure with Bellows or Bourdon tube acting as the primary transducer *i.e.*, as a force summing device. The two arrangements are shown in Figs. 29.21 and 29.22. The pressure is converted into displacement which is sensed by the LVDT and transduced into a voltage.

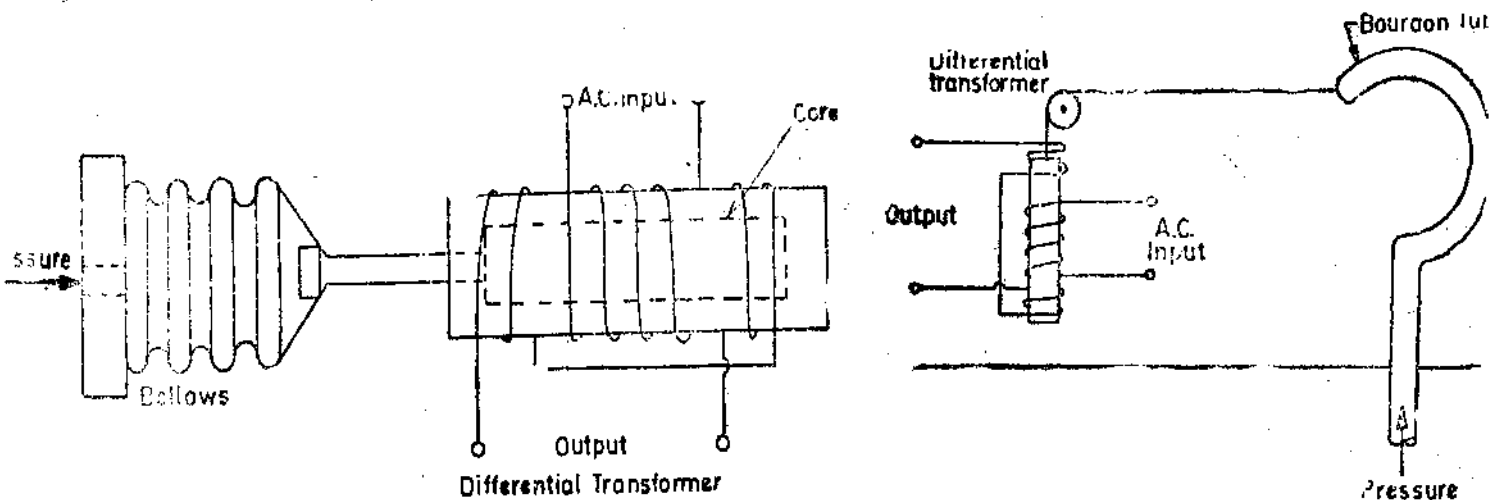

Fig. 29.21. Measurement of pressure with Bellows and LVDT. Fig. 29.22. Pressure measurement with Bourdon tube and LVDT.

4. Capacitive Transducers. Capacitive transducers are used for measurement of pressure by converting the pressure into a displacement. The displacement is sensed by a capacitive transducer using a differential arrangement as explained on page 798. This arrangement gives a linear relationship between output voltage and displacement (and hence pressure) as shown in Eqn. 25.52.

The use of a three terminal variable differential circuit capacitor is shown in Fig. 29.23. Spherical depressions of a depth of about 0.025 mm are ground into the glass discs. These depressions are coated with gold to form the two fixed plates of the differential capacitor. A thin stainless steel diaphragm is clamped between the discs, acts as the movable plate.

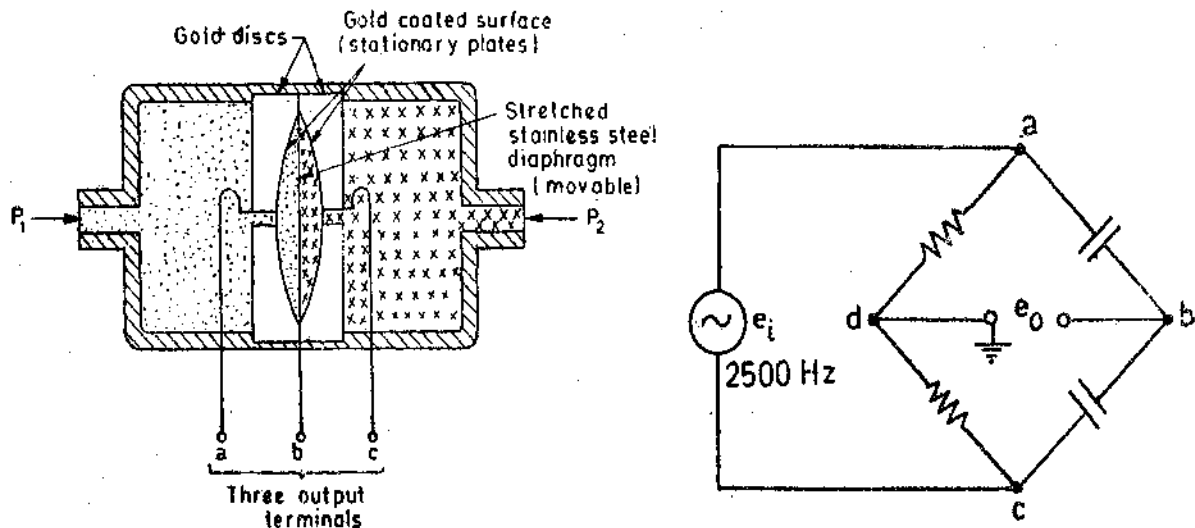

Fig. 29.23. Capacitive transducer and bridge circuit.

With equal pressures applied (i.e. $P_1 = P_2$) the diaphragm is in neutral position and the bridge is balanced. The output voltage e_o , is zero under the conditions. If one pressure is made greater than the other, the diaphragm deflects in proportion to the differential pressure, giving an output voltage, e_o , from the bridge terminals. This output voltage is proportional to the differential pressure. For an opposite pressure difference, the output voltage shows a 180° phase shift. This voltage may be amplified by an emitter follower amplifier which gives a high input impedance. A direction sensitive d.c. output voltage may be obtained by using a phase sensitive demodulator and a filter circuit.

The use of capacitive transducers is not common because of low sensitivity. Also capacitive transducers require high carrier frequencies (typically 2500 Hz) for dynamic pressure measurements.

5. Photoelectric Transducers. The photoelectric transducer makes use of the properties of a photo-emissive cell or photo-tube. A photo tube is described in details on page 626. It is shown in Fig. 19.21 and its characteristics are given in Fig. 1.23 page 628.

From the characteristics of Fig. 19.23, we find that for voltage above approximately 20 V, the output is nearly independent of the applied anode voltage but entirely depends upon the amount of incident light. The current through the photo tube produced as a result of incident light is very small. This current is the output of the photo-electric transducer. As the current is small (of the order of a few μA), it must be amplified to provide a usable output.

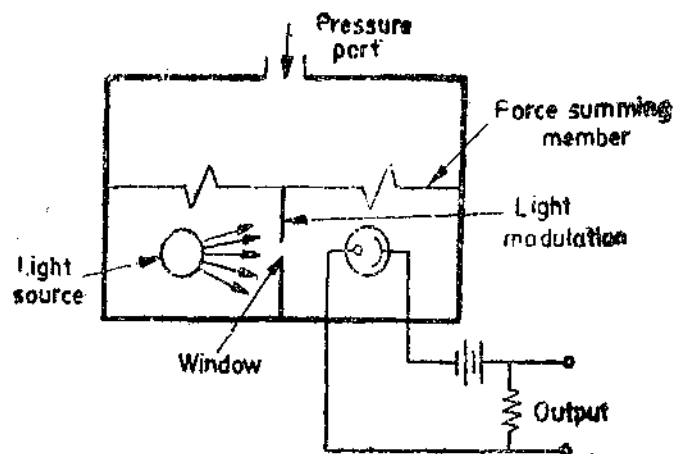

Fig. 29.24. Photoelectric transducer for measurement of pressure.

The photo-electric transducer of Fig. 29'24 uses a photo-tube and a light source separated by a small window, whose aperture is controlled by the force summing member of the pressure transducer.

The displacement of the force summing member modulates quantity of incident light falling on the phototube (since the applied pressure or force changes the position of the force summing member which in turn changes the position of the window thus causing a change in incident light). According to curves given in Fig. 19'23 page 628 a change in light intensity varies the photo-emissive properties at a rate approximately linear with displacement. This transducer can use either a stable source of light or an a.c. modulated light.

Advantages. (i) It has a high efficiency.

(ii) It can be used for both static and dynamic conditions but it does not respond to high frequency light variations.

Disadvantages. (i) It has a poor long term stability.

(ii) It requires a large displacement of the force summing member in order to produce a detectable output.

6. Piezoelectric Transducers. Piezoelectric crystals produce an emf when they are deformed. The force or displacement or pressure to be measured is applied to the crystal. The pressure is applied to the crystal through a force summing member. This causes a deformation which produces an emf that is a function of the deformation. This output emf may be measured to know the value of applied force and hence the pressure.

Advantages. (i) This transducer needs no external power and is therefore self-generating (active types).

(ii) It has a very good high-frequency response.

Disadvantages. (i) The principle disadvantage is that this transducer cannot measure static pressure.

(ii) The output of the transducer is affected by changes in temperature. Therefore temperature compensating devices have to be used.

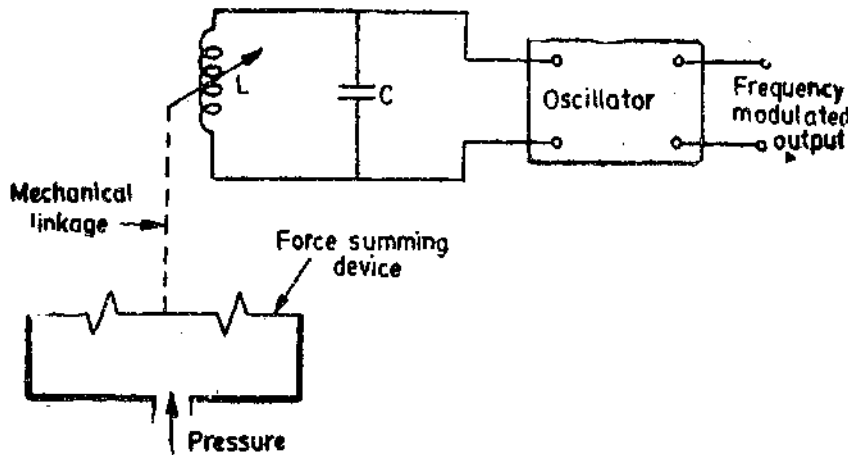

Fig. 29'25. Basic elements of an oscillation transducer.

7. Oscillation Transducers. These transducers use a force summing member to change the capacitance, C , or inductance, L , of an LC oscillator circuit. Fig. 29'25 shows the basic elements of LC transistor oscillator whose output frequency is affected by a change in the inductance of a coil. The change in inductance is caused by the force summing member acting upon an inductive device

The output of oscillator is a modulated output and can be demodulated and calibrated in terms of pressure or force applied.

Advantages. (i) This transducer measures both dynamic and static phenomena.

(ii) This transducer is very useful for telemetry applications.

Disadvantages. (i) This transducer has a very limited temperature range. (ii) It has poor thermal stability.

(iii) It has a low accuracy and therefore is used only in low accuracy applications.

Example 29'14. A piezoelectric pressure transducer gives an output of 1 mV per 100 kN/m². It feeds into an amplifier which may be considered as having negligible output impedance and a voltage gain of 25. The amplifier output is taken to an oscilloscope having calibrated vertical sensitivities of 1, 5, 20, 100 and 500 mV/mm. The viewing area of the oscilloscope screen is 100 mm × 100 mm. The transducer is used to measure a pressure fluctuating at a frequency of 50 Hz between upper and lower level of about 700 kN/m² and 100 kN/m² respectively. Assuming that the trace seen on the screen is steady and the peak to peak amplitude may be estimated correctly within ±1 mm, what is (a) optimum setting of the vertical sensitivity, and (b) the likely maximum reading error in a measurement of the peak amplitude of wave in kN/m².

Solution.

(a) The two extreme pressures of 700 kN/m² and 100 kN/m² give the outputs as :
 $700 \times (1/100) \times 25 = 175 \text{ mV}$ and $100 \times (1/100) \times 25 = 25 \text{ mV}$.

The corresponding peak to peak voltages are : $2 \times 175 = 350 \text{ mV}$, and $2 \times 25 = 50 \text{ mV}$.

Suppose we use the sensitivity of 1 mV/mm.

∴ Deflection on the screen corresponding to maximum pressure = $350/1 = 350 \text{ mm}$.

Since the length of the screen is 100 mm, the waveform is out of range and hence the 1 mV/mm should not be used.

Let us try the 5 mV/mm setting.

∴ The peak to peak deflection = $350/5 = 70 \text{ mm}$.

This is within the range of the screen of the scope.

If we use 20, 100 or 500 mV/mm, no doubt, the pattern will be visible on the screen but the sensitivity will be lower as the deflections are lower. Hence the setting 5 mV/mm is the optimum setting.

(b) A ±1 mm error corresponds to an input peak to peak pressure of :

$$\pm \left[1 \text{ mm} \times \frac{5 \text{ mV}}{\text{mm}} \times \frac{1}{25} \times \frac{100 \text{ kN/m}^2}{1 \text{ mV}} \right] = \pm 20 \text{ kN/m}^2.$$

MEASUREMENT OF LOW PRESSURE (VACUUM MEASUREMENTS)

29'18. Vacuum Gauges

These pressure gauges are used primarily for measuring pressure below atmospheric pressure, which is often referred to as vacuum. The science of low pressure measurement is rather a specialized field which requires considerable care on the part of the experimentalist. The wide range of pressures to be measured under the general heading of vacuum measurement makes the problem an extremely extensive one. This range extends from the normal atmospheric pressure of 760 mm of mercury column down to 10⁻⁸ mm of mercury column.

A common unit of low pressure is the micron, which is one millionth of a metre (0'001 mm) of mercury column. Very low pressure may be defined as any pressure below 1 mm of mercury, and an ultra low pressure is a pressure is less than a millimicron (10⁻³ micron) or 10⁻⁶ mm of mercury. Torr is 1 mm of mercury column and therefore a millimicron is 1 mirco torr.

There are two basic methods for measurement of low pressure :

(1) **Direct Methods.** The direct methods of measurement involve measurement of a displacement as a result of application of the pressure.

(2) **Indirect or Inferential Methods.** These methods involve the measurement of pressure through measurement of certain other properties which depend upon the pressure to be measured. The pressure controlled properties which may be utilized for measurement of pressure are volume and thermal conductivity etc.

Pressure is measured by direct methods using spiral Bourdon tubes, flat and corrugated diaphragms, capsules and various forms of manometers. These devices have been discussed earlier. They need not be discussed further except to state that these devices are useful for measurement of pressures down to about 10 mm of mercury column. For measurement of pressures below this value, indirect methods are used. Indirect or inferential methods for pressure measurement are used which involve a property that is pressure dependent and is examined for the measurement of pressure. The property selected must be sensitive to changes in pressure in the ranges required.

29'19. Thermocouple Vacuum Gauge

This gauge operates on the principle that at low pressures the thermal conductivity of a gas is a function of pressure. A thermocouple vacuum gauge consists of a heater element (heated to a temperature of 50° to 400°C by a known constant current) having a thermocouple in contact with its centre as shown in Fig. 29'26.

The heater element and thermocouple are enclosed in a glass or metal envelope which is sealed into the vacuum system. The heater element is heated by a constant current and its temperature depends upon the amount of heat which is lost to the surroundings by conduction and convection. At pressures below 10^{-3} mm Hg, the temperature of the heater wire is a function of the pressure of surrounding gas. Thus the thermocouple provides an output voltage which is a function of temperature of heater element and consequently of the pressure of the surrounding gas. The moving coil instrument may be directly calibrated to read the pressure.

The advantages of the thermocouple gauges are that they are inexpensive. However, they are subject to burnout if exposed at rugged and atmospheric pressure when hot and the current is flowing.

29'20. Pirani Gauges

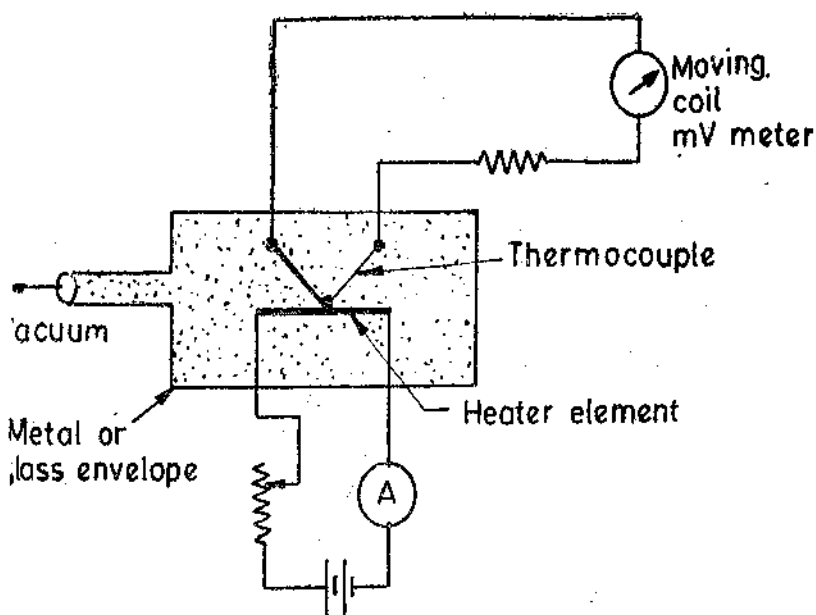

Fig. 29'26. Thermocouple vacuum gauge.

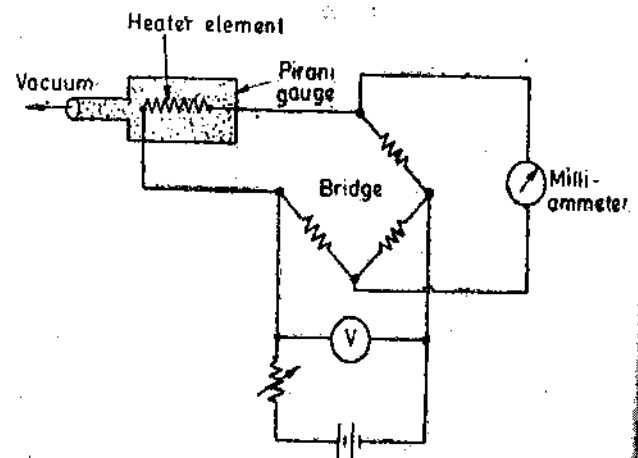

Fig. 29'27. Measurement of low pressures with Pirani Vacuum Gauge.

The operation of a Pirani gauge depends on variation of the thermal conductivity of a gas with pressure. For pressures down to about 1 mm Hg the thermal conductivity is independent of pressure, but below this an approximately linear relationship exists between pressure and the thermal

conductivity. At very low pressures the amount of heat conducted becomes very small and the method cannot be used.

The thermal conductivity of the gas is measured by detecting the amount of heat lost from an electrically heated wire placed in the gas. Heat is conducted from wire by conduction through the gas and greater the thermal conductivity of the gas, the lower will be the temperature of the heater wire. Now since electrical resistance varies with temperature, the resistance of the heater wire is a measure of the pressure. A Wheatstone bridge as shown in Fig. 29.27 may be used to measure the resistance of the heater wire. Alternatively the milliammeter carrying a current on account of unbalance in the bridge, may be calibrated to read the pressure directly.

Some heat is lost from heater by radiation and conduction and along leads, but these effects do not depend on pressure or on the presence of gas. The compensation for this effect may be carried out by introducing a similar Pirani element in an opposite arm of bridge. This second element is enclosed in a sealed container evacuated to a very low pressure.

Pirani gauge is useful for pressures ranging from 10^{-1} to 10^{-3} mm of Hg. Pirani gauges are rugged, inexpensive and usually more accurate than thermocouple gauges. However, they must be individually calibrated and checked frequently.

29.21. Ionization Type Vacuum Gauge

Ionization is the process of removing an electron from an atom producing a free electron and a positively charged ion. Ionization may be produced by the collision of a high speed electron from the atom. Fig. 29.28 shows the essential features of an ionization type gauge. Electrons are emitted from heated cathode using a filament and are accelerated towards the grid, which is positively charged. Some of the electrons are captured by the grid, producing grid current I_g . Electrons having high kinetic energy pass through and cause ionization of gas atoms.

The positive ions so produced are attracted to plate (which is at negative potential) and a current I_p is produced in the plate circuit.

The positive ions so produced are attracted to plate (which is at negative potential) and a current I_p is produced in the plate circuit.

It is found that the pressure of the gas is proportional to ratio of plate to grid current.

$$p = \frac{1}{S} \frac{I_p}{I_g} \quad \dots(29.18)$$

where S = constant of proportionality.

S is called the sensitivity of the gauge. A typical value for nitrogen is $S = 20 \text{ torr}^{-1}$. However, the exact value must be determined by calibration of the particular gauge since sensitivity S is a function of the geometry of the tube and the gas filled in it. Pressures that can be measured by ionization gauge range from 10^{-3} to 10^{-8} mm of Hg.

The disadvantage of these gauges is that the filament can burn out quickly if it is heated before the pressure is at a low value. For this reason it is usually necessary to have a Pirani or thermocouple gauge in the system to ensure a low enough vacuum. Also an automatic cut out circuit is used to protect the ionization tube in case of a system leak to break.

These gauges must be carefully installed—in particular, absorbed gases must be eliminated. Voltages required are in the range 50 to 300 V.

MEASUREMENT OF TORQUE

9.22. Torque Transducers

Dynamic measurement of torque transmitted by a rotating shaft is based upon the angular displacement or twist in the shaft in a calibrated length of torque tube attached to the shaft. The

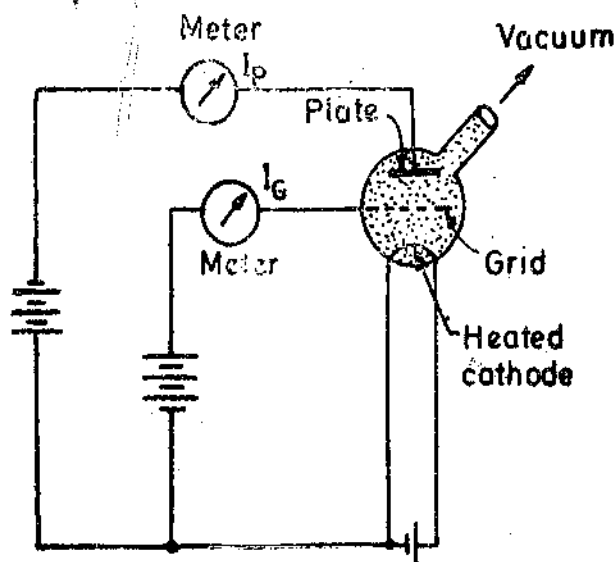

Fig. 29.28. Ionization type vacuum gauge.

strain is sensed by transducers and is measured. The strain measurements are then interpreted in terms of torque by proper calibration. These measurements can be used for measurement of power if combined with proper speed measuring devices.

A number of physical effects and devices can be used for measurement of relative angular displacement - strain by piezo-resistive (strain gauge) variable inductance, and magnetostrictive effects. The various methods are described below.

29.23. Strain Gauge Torque Meters

The principle of this method is explained by Fig. 29.29. Two strain gauges are mounted on a shaft at an angle 45° to each other. The torque is given by :

$$T = \frac{\pi G (R^4 - r^4)}{2L} \theta \quad \text{N-M} \quad (29.19)$$

where G = modulus of rigidity ; N/m^2 , R = outer radius of shaft ; m,
 r = inner radius of shaft ; m, L = length of shaft ; m,
 and θ = angular deflection of shaft ; rad.

The strain gauges attached at 45° degrees to the axis of the shaft as shown will indicate strains of

$$\epsilon_{45^\circ} = \pm \frac{TR}{\pi G (R^4 - r^4)} \quad \dots(29.20)$$

A strain may be measured by electrical means to indicate the torque. Multiple strain gauges may be installed and connected in a bridge circuit configuration so that any deformation due to axial or traverse loads is cancelled out in the final readout.

The strain in the shaft may be measured by means of strain gauges attached to its surface. The gauges should be so mounted that they give maximum sensitivity to the strains produced by torsion. The theory of two dimensional stress systems shows that, for a shaft subjected to pure torsion, the gauges will be strained in the directions of their major axis if they are mounted at 45° to the axis of the shaft. The normal method is to mount a complete strain gauge bridge on the shaft. The strain bridge configuration generally used for measurement of torque is shown in Fig. 29.30 (a). In this arrangement two strain gauges are subjected to tensile stresses while the other two experience

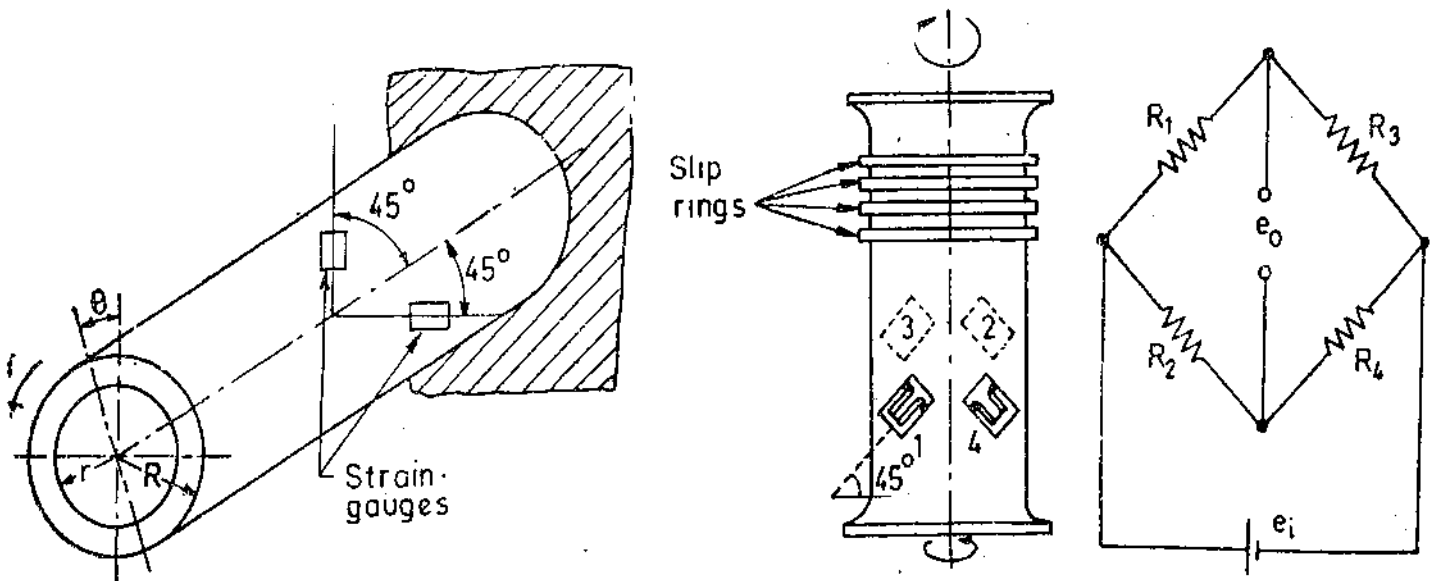

Fig. 29.29. Measurement of stress in a hallow shaft.

(a) Shaft with strain gauges
 Fig. 29.30. Measurement of torque of rotating shaft using strain gauges. (Bridge)

compressive stresses. The gauges must be precisely at 45° with the shaft axis. Gauges 1 and 2 must be diametrically opposite, as must gauges 3 and 4.

This arrangement has the following advantages :

- (i) it is fully temperature compensated,
 - (ii) it provides automatic compensation for bending and axial loads,
- and (iii) it gives the maximum sensitivity for a given torque.

The main difficulties associated with the use of this arrangement is the connection of the bridge to its power source and display arrangement. Slip rings are used for this purpose. These are conducting rings attached to the shaft, but insulated from it, with one of the slip rings connected to each of the bridge terminals. Rubbing contact is made between the rings and the stationary brushes, which are connected to the input and output equipment.

29.24. Inductive Torque Transducer

Fig. 29.31 (a) shows the use of an inductance transducer. Flange A carries a coil and flange B, an iron core. This core moves in and out of the coil according to relative displacement of the two flanges. Therefore inductance of the coil is altered on account of relative displacement. The coil is used as an arm of an a.c. bridge. The output of the a.c. bridge depends upon the inductance of the coil which in turn depends upon the position of core and thus on the displacement. Since the displacement is dependent upon the torque and hence the bridge output can be directly calibrated to read the torque.

A scheme which gives higher sensitivity and better linearity uses four inductive transducers with the coils connected as four arms of an a.c. bridge. The arrangement is shown in Fig. 29.32(b).

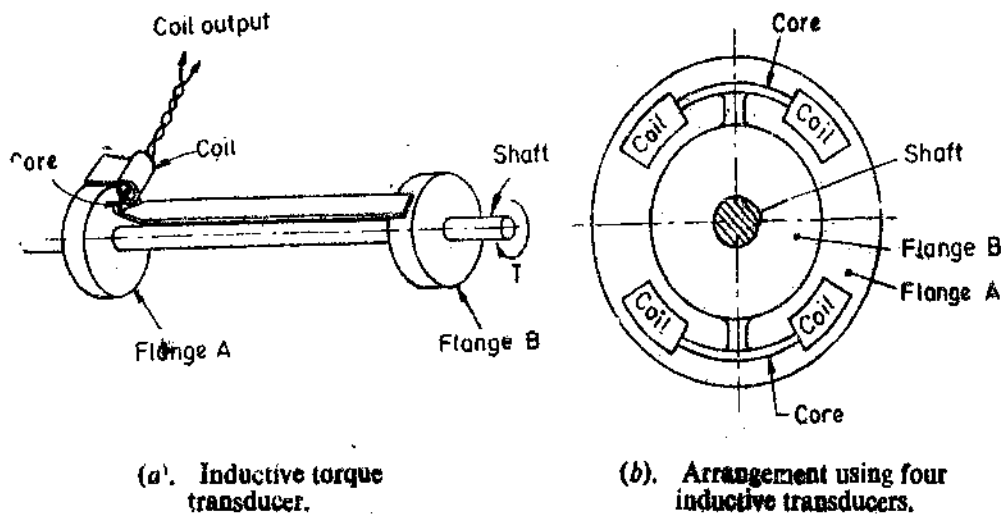

Fig. 29.31

This arrangement is such that a torque applied to the shaft in a given direction moves the cores in such a way that the inductance of two coils increases, while the inductance of the other two coils decreases. (This arrangement is similar to use of four strain gauges, two in tension and two in compression). Thus the sensitivity of the bridge is increased four times as compared to the sensitivity obtained with a bridge using only one inductive transducer.

29.25. Digital Methods

Digital timing techniques can also be used for determination of relative displacement between two flanges A and B. Suppose the flanges are made in the form of single toothed wheels as shown in Fig. 29.32. The teeth produce voltage pulses in inductive pickups C and D respectively. When no torque is applied to the shaft, the teeth are perfectly aligned and hence the voltage pulses are produced in C and D simultaneously. If the two pulses are compared by an electronic timer, the time difference shown will be zero. When a torque is applied to the shaft, there is a relative displacement

between the two flanges. This produces a phase shift between the pulses generated in the inductive pickups *C* and *D*. When these pulses are compared with the help of an electronic timer, it will show a time interval between the two pulses. This time interval is proportional to the relative displacement of the two flanges which in turn is proportional to torque. Therefore, the ratio of this interval to the time taken for one complete revolution gives the relative displacement as a fraction of a revolution.

The advantage of digital methods is that they eliminate errors arising from the use of slip rings. There is no leakage of the signal and also there is no noise problem.

There are other ways of obtaining output signals from digital pickups. Fig. 29'33 shows multi-toothed wheels which replace the single toothed wheels of Fig. 29'32. The pickups are either magnetic or photo-electric. In case multiple toothed wheels are replaced by single toothed wheels, the output of the pickoffs is perfectly sinusoidal. The two outputs are exactly in phase if the two wheels are correctly aligned.

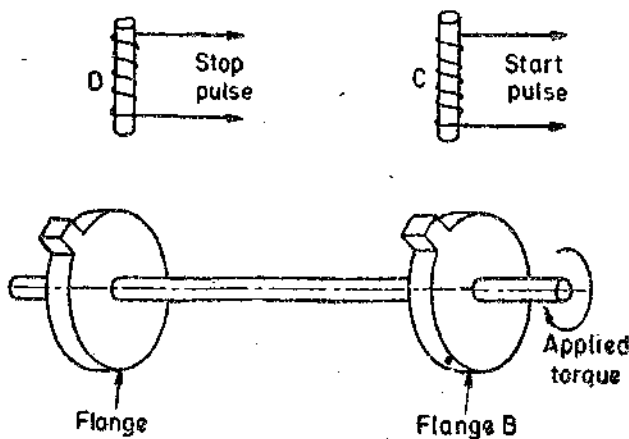

Fig. 29'32. Torque transducer using single toothed flanges and inductive pickups.

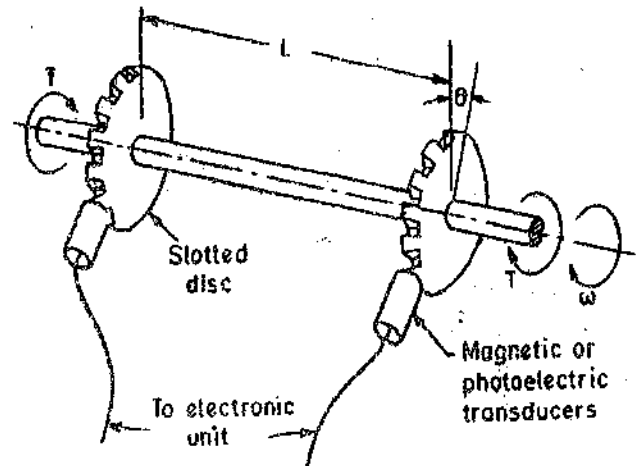

Fig. 29'33. Torque measurements of rotating shafts using slotted discs and pickups.

The output voltage progressively becomes out of phase as the torque increases since an increase in torque results in relative displacement of the two flanges. The phase difference may be measured with the help of a cathode ray oscilloscope. The phase difference may also be measured by converting it to suitable analog or digital signals.

29'26 Magneto-strictive Transducers

The action of Magneto-strictive transducers depends upon the change which occurs in the permeability of magnetic materials when they are subjected to strain. The permeability decreases with positive strain and increases with negative strain.

The torque transducers described earlier use an attachment with the shaft whose torque is to be measured resulting in substantial increase in the length of shaft. Magnetostrictive transducers can operate without any attachments or modifications to the shaft. They are very compact in size.

It is well known that a shaft subjected to pure torsion, the highest positive and negative strains are experienced in the two directions at 45° to the shaft axis. Thus, if flux paths can be established in these two directions, and their changes can be detected, a method for torque measurement can be evolved.

This method is illustrated in Fig. 29.34. Two a.c. energized coils, wound on iron cores, are positioned close to the shaft so that their flux paths through the material of the shaft coincide with the directions of maximum strain. The coils form adjacent arms of an a.c. bridge. The inductance of one of the coils increases due to increase in permeability and the inductance of other coil decreases due to decrease in permeability. The bridge is initially balanced when there is no torque applied and the two coils have equal inductance (or reactance). But when the torque is applied the bridge becomes unbalanced on account of increase in inductance (or reactance) of one coil and decrease in inductance (or reactance) of the other coil. This is due to differential change in inductance (or reactance) of the two coils, caused by change in permeability of flux paths due to application of torque. Hence, the voltage output of the a.c. bridge is indicative of the torque applied.

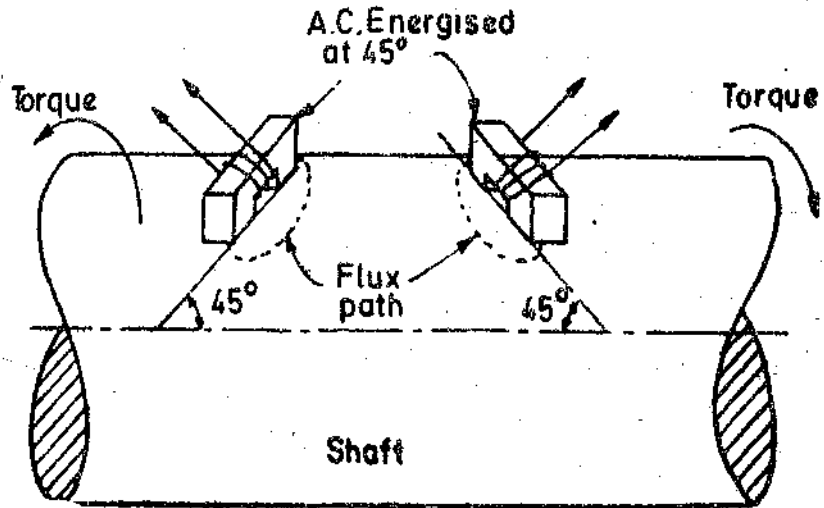

Fig. 29.34. Magneto-strictive transducer.

Example 29.15. A mild steel shaft is used to connect a motor drive to a constant load torque. A foil strain gauge having a resistance of 120 Ω and a gauge factor 2 is mounted on a shaft with its active axis at angle 45° to the axis of the shaft as shown in Fig. 29.35. The shear modulus of steel is 80 GN/m², the shaft radius is 15 mm and the change in strain gauge resistance due to the load is 0.24 Ω. Find the load torque.

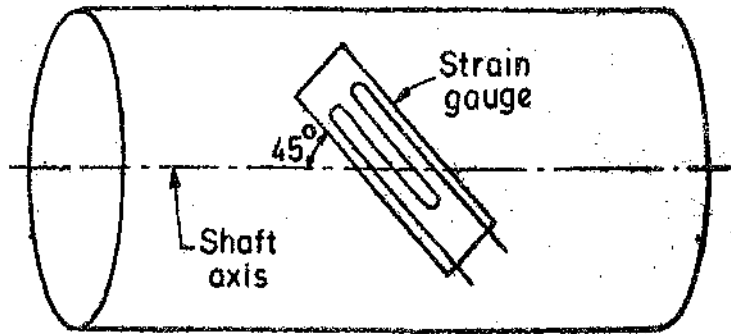

Fig. 29.35

Solution :

$$\text{Angle of shear } \theta = \frac{2T}{\pi G r^3}$$

where G is the shaft shear modulus, r is the radius of the shaft and T is the applied torque.

An area of the shaft surface, originally square with the sides of unit length, is deformed by strain to a parallelogram. The original length of the diagonal is $\sqrt{2}$. If the angle of shear, θ , is small, the length of the diagonal of the parallelogram is longer than the diagonal of the square. The difference in lengths is $\theta/\sqrt{2}$. Therefore, the longitudinal strain is .

$$\epsilon = \frac{\Delta L}{L} = \frac{\theta/\sqrt{2}}{\sqrt{2}} = \frac{\theta}{2}$$

But $\frac{\Delta R}{R} = G_f \epsilon = 2 \times \frac{\theta}{2} = \theta$. or $\theta = \frac{\Delta R}{R} = \frac{0.24}{120} = 2 \times 10^{-3}$ rad.

\therefore Torque $T = \frac{\pi G r^3}{2} \theta = \frac{\pi \times 80 \times 10^9 \times (15 \times 10^{-3})^3}{2} \times 2 \times 10^{-3} = 848$ Nm.

Example 29.16. A shaft is to transmit power up to 44 kW at a constant speed of 25 rps, and it is proposed that the torque be sensed by a pair of torque strain gauges bonded to a specially machined portion of the shaft. The gauges are to be connected in push-pull in an equiarmed voltage

sensitive bridge, the output of which is to be calibrated in power units. If the maximum strain value of the gauges is 0.0015, their resistance 120 Ω and gauge factor 2.1, calculate :

(a) the diameter of steel shaft to which they should be bonded if its modulus of elasticity is 200×10^9 N/m²,

(b) the output voltage at full power if the excitation voltage of the bridge is 6 V,

(c) the sensitivity of the bridge is in V/kW.

Solution :

(a) Angular speed $\omega = 2\pi \times 25 = 157$ rad/s. Torque $T = \frac{P}{\omega} = \frac{44000}{157} = 280.25$ Nm.

Maximum value of strain $\epsilon_{max} = 0.0015$.

\therefore Maximum value of direct stress $s_{max} = 0.0015 \times 200 \times 10^9$ N/m² = 300 MN/m².

For pure torsion, the maximum shear stress, τ , has the same value.

Using relationship, $\frac{T}{I_p} = \frac{\tau}{d/2}$ we can find the diameter.

Polar moment of inertia $I_p = \frac{\pi}{32} d^4$.

$\therefore \frac{280.25}{(\pi/32)d^4} = \frac{300 \times 10^6}{d/2}$ or diameter of shaft $d = 0.0168$ m = 16.8 mm.

(b) The output voltage of an equal armed bridge using two active elements is :

$$e_0 = \left(\frac{\Delta R/R}{2} \right) e_i$$

Now $\frac{\Delta R}{R} = \epsilon G_f = 0.0015 \times 2.1 = 3.15 \times 10^{-3}$.

\therefore Output voltage $e_0 = \frac{3.15 \times 10^{-3}}{2} \times 6$ V = 9.45 mV.

(c) Overall sensitivity of bridge $S = \frac{9.45 \times 10^{-3}}{44}$ V/kW = 215 μ V/kW.

Example 29.17. A digital timer is used to determine the torque in a rotating shaft using single toothed flanges and inductive pickups. Static calibration shows that the flanges twist by an angle of one degree for an applied torque of 1000 Nm. In a test with the shaft rotating at 500 rpm, the torque calculated from the timer readings is 1200 Nm. What is the maximum probable error, if final digit on the timer display represents units of 10^{-5} s, and accuracy of instrument is specified as 0.05 per cent of the reading ± 1 in the final digit ?

Solution. 1 degree = 1000 Nm. The shaft is rotating at a speed of 500 rpm.

\therefore Angular speed = $\frac{360 \times 500}{60} = 3000$ degrees/second.

or 1 s = 3000 degrees = 3000 \times 1000 = 3,000,000 Nm

$\therefore 10^{-5}$ s = $10^{-5} \times 3,000,000 = 30$ Nm

The error is thus : $\frac{0.05}{100} \times 1200 = 0.6$ Nm

$$\begin{array}{r} +30 \text{ Nm} \\ \hline \text{Total} \quad = 30.6 \text{ Nm} \end{array}$$

Hence percentage error = $\frac{30.6}{1200} \times 100 = 2.55\%$.

MEASUREMENT OF LINEAR VELOCITY

29.27. Electromagnetic Transducers

The most commonly used transducer for measurement of linear velocity is the **electromagnetic transducer**. This transducer utilizes the voltage produced in a coil on account of change in flux linkages resulting from change in reluctance.

In general, the output voltage output from a coil is given by :

$$e_0 = \frac{d\phi}{dt} = \frac{N}{R} \frac{di}{dt} - \frac{Ni}{R^2} \frac{dR}{dt} \quad (\text{See Eqn. 25'39 page 781})$$

$$\text{Supposing } i \text{ is constant } \therefore e_0 = \frac{Ni}{R^2} \cdot \frac{dR}{dt} \quad \dots(29'21)$$

$$\text{Hence output voltage : } e_0 \propto \frac{dR}{dt} \quad \dots(29'22)$$

Eqn. 29'22 is derived on the basis of following explanation.

If the average value of reluctance R is considerably greater than the variations in R , the quantity Ni/R^2 is approximately constant. Therefore the rate of change of flux is directly proportional to the rate of change of reluctance. The change in flux produces an output voltages and hence the output voltage is directly proportional to the rate of change of reluctance. The reluctance varies directly as the length of air gap and therefore the output voltage is directly proportional to rate of change of air gap and hence to the velocity. (This condition is only satisfied when the length of air gap is small). Thus this type of transducer is velocity sensitive.

The electro-magnetic transducers are classified into two categories :

- (i) Moving magnet type, and (ii) Moving coil type.

29.27.1. Moving Magnet type. The constant mmf (polarizing field) Ni , can be provided by a solenoid of N turns and carrying a constant current i . But the electromagnetic transducers use a permanent magnet which provides a constant polarizing field.

Fig. 29'36 shows a moving magnet type of transducer. The sensing element is a rod that is rigidly coupled to the device whose velocity is being measured. This rod is a permanent magnet. There is a coil surrounding the permanent magnet. The motion of the magnet induces a voltage in the coil and the amplitude of the voltage is directly proportional to the velocity. For a coil placed in a magnetic field, the voltage induced in the coil is directly proportional to the velocity.

The polarity of the output voltage determines the direction of motion. The sensitivity of this transducer is stated in terms of mV/mm-s .

Advantages. (i) The maintenance requirements of these transducers are negligible, because there are no mechanical surfaces or contacts.

(ii) The output voltage is linearly proportional to velocity.

(iii) These transducers can be used as event markers which are robust and inexpensive to manufacture.

Disadvantages. (i) The performance of these transducers is adversely affected by stray magnetic fields. These fields cause noise.

(ii) The frequency response is usually limited and is stated.

(iii) These transducers are not very useful for measurement of vibrations because their calibration deteriorates as contact with steel tools etc. leads to progressive demagnetization.

There are two other forms of electromagnetic transducers which are described below :

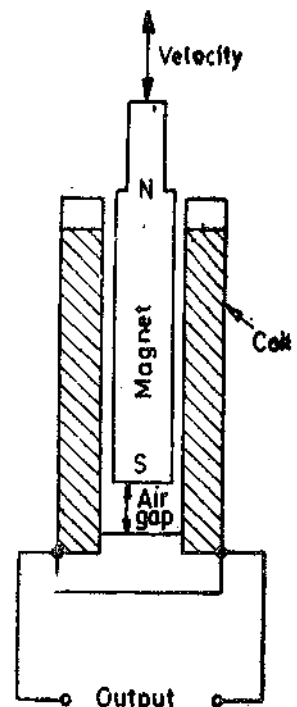

Fig. 29'36 Moving magnet type transducer.

29'27'2. Moving Coil type Velocity Transducer. The moving coil type velocity transducer shown in Fig. 29'37 operates essentially through the action of a coil moving in a magnetic field. A voltage is generated in the coil which is proportional to the velocity of the coil. (Note that in this transducers the functions of permanent magnet and the coil are reversed from their functions as used in transducer of Fig. 29'36).

The advantages of this transducer are :

(i) This is a more satisfactory arrangement as the system now forms a closed magnetic circuit with a constant air gap.

(ii) The whole device is contained in an antimagnetic case which reduces the effects of stray magnetic fields.

Another type of velocity transducers uses a pivoted arm on which a coil is mounted. There is a mass attached at the end of the arm. The velocity to be measured is applied to the arm and therefore the coil moves in the field of a permanent magnet.

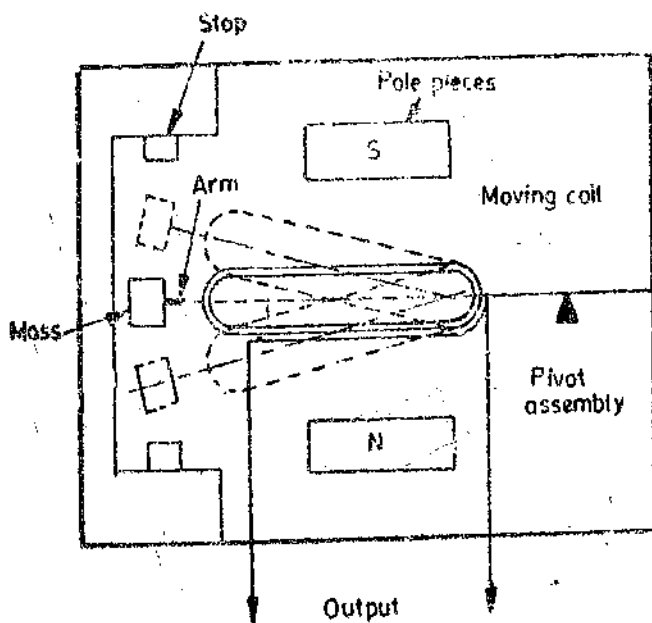

Fig. 29'37. Moving coil type velocity transducer.

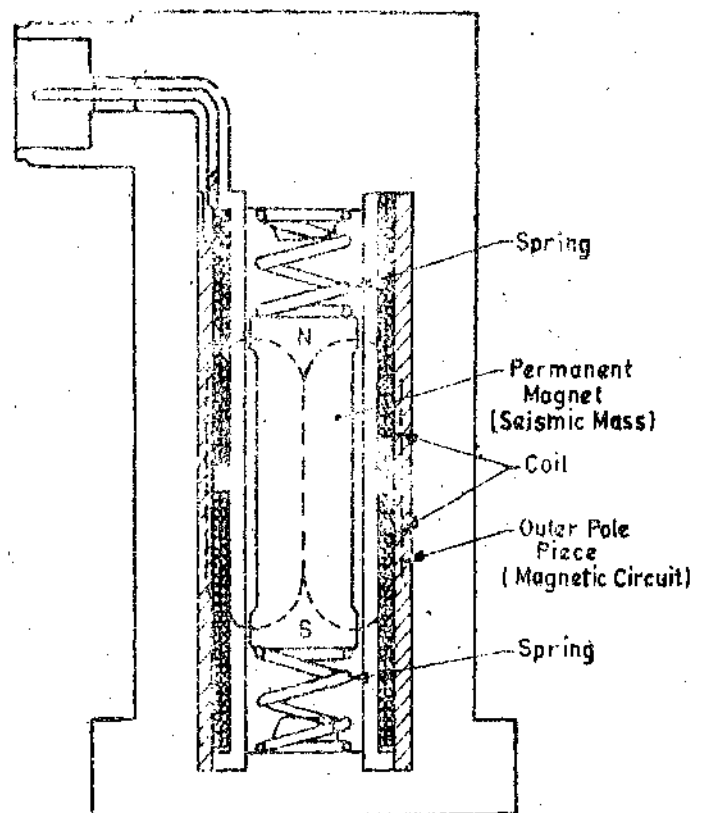

Fig. 29'38. Seismic type velocity transducer.

A voltage is generated on account of motion of the coil in the magnetic field. The output voltage is proportional to the velocity. This type of transducer is generally used for measurement of velocities developed in a linear, sinusoidal or random manner. Damping is obtained electrically, thus assuring high stability under varying temperature conditions.

Seismic type Velocity Transducer. In this type of construction a permanent magnet is supported between two springs and fitted with low friction bearing rings as shown in Fig. 29 38. If this transducer is attached to an object which is vibrating at a frequency that is greater than the low natural frequency of the transducer, the magnet appears to be stationary in space. The case and coil oscillate around the magnet resulting in an output voltage which is proportional to the amplitude of the vibration. The frequency of output is equal to the frequency of the vibration.

Both moving coil and seismic transducers have the disadvantage that the connections must be made to the moving member.

MEASUREMENT OF ANGULAR VELOCITY

29'28. Introduction

In many cases the only way to measure linear velocity is to convert it into angular velocity. For example a speedometer uses the wheel rotational speed as a measure of the linear road speed. The disadvantage with measurement of linear velocity arises because a fixed reference must be used and if the moving object has to travel large distances, the detection becomes impossible. Hence angular velocity transducers are used.

The measurement of angular speed may be made with tachometers which may be either mechanical or electrical type.

29'29. Electrical Tachometers

The electrical tachometers are preferred over mechanical tachometers for all applications because these tachometers offer all the advantages associated with electrical transducers. The various types of electrical tachometers are discussed below :

29'29'1. Electromagnetic Tachometer Generators. There are two types of electromagnetic tachometer generators called tachogenerators. These are :

- (i) D.C. tachometer generators, and (ii) A.C. tachometer generators.

1. D.C. Tachometer Generators. D.C. tachometer generators consist of a small armature which is coupled to the machine whose speed is to be measured. This armature revolves in the field of a permanent magnet. The emf generated is proportional to the product of flux and speed. Since the flux of the permanent magnet is constant, the voltage generated is proportional to speed. The polarity of output voltage indicates the direction of rotation. This emf is measured with the help of a moving coil voltmeter having a uniform scale and calibrated directly in terms of speed.

Fig. 29'39 shows a d.c. tachometer generator. A series resistance is used in the circuit for the purpose of limiting the current from the generator in the event of a short circuit on the output side.

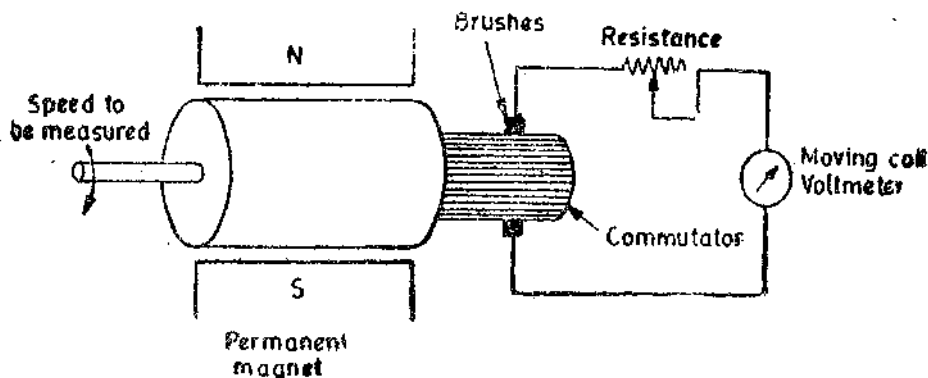

Fig. 29'39. D.C. Tachometer Generator.

Advantages. The chief advantages of this tachometer are :

- (i) The direction of rotation is directly indicated by the polarity of the output voltage.
(ii) The output voltage is typically 10 mV/rpm and can be measured with conventional type d.c. voltmeters.

Disadvantages. The disadvantages are :

(i) brushes on small tachometer generators often produce maintenance problems, as their contact resistance may vary and produce appreciable error. Thus the commutator and the brushes require periodic maintenance.

(ii) The input resistance of meter should be very high as compared with output resistance of generator. This is required to limit the armature current to small value. If the armature current is large, the field of the permanent magnet is distorted giving rise to non-linearity.

2. A.C. Tachometer Generators. In order to overcome some of the difficulties mentioned above, a.c. tachometer generators are used. The tachometer generator has rotating magnet which may be either a permanent magnet or an electromagnet. The coil is wound on the stator and therefore the problems associated with commutator (as in d.c. tachometers) are absent.

The rotation of the magnet causes an emf to be induced in the stator coil. The amplitude and frequency of this emf are both proportional to the speed of rotation. Thus either amplitude or frequency of induced voltage may be used as a measure of rotational speed.

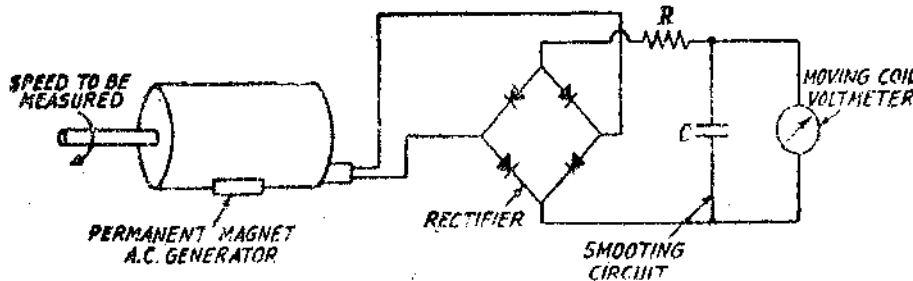

Fig. 29'40. A.C. Tachometer Generator.

When amplitude of induced voltage is used as a measure of speed, the circuit of Fig. 29'40 is used. The output voltage of a.c. tachometer generator is rectified and is measured with a permanent magnet moving coil instrument.

Limitations. (i) The difficulty with this system is that at low speed the frequency of output voltage is low and hence it is very difficult to smooth out the ripples in the output voltage wave-shape and hence a.c. tachometer generators are designed to have a large number of poles so that the frequency of output voltage is high even at low speeds.

(ii) High speeds also present a problem. At high speeds, the frequency increases and therefore, the impedance of the coils of tachogenerator increases. If good linearity is to be maintained the input impedance of the display device must be considerably larger than the impedance of the coils.

However, modern electrical instruments such as counters, make it desirable to use frequency of output voltage as a measure of speed. This is because the frequency is not affected by temperature, impedance of meters, and other systematic errors that can affect the voltage readings. Thus the frequency as measured by electronic counters is a measure of speed.

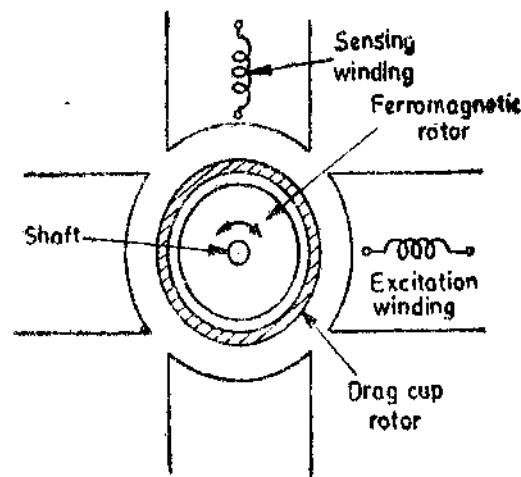

Fig. 29'41. A.C. tachometer generator.

29'29'2. Drag Cup Rotor A.C. Tachogenerator. Fig. 29'41 shows a drag cup rotor type a.c. tachogenerator. The tachogenerator consists of a stator and a rotor. The stator has two windings mounted at 90° to each other. The two stator windings are : (i) excitation winding, and (ii) sensing winding.

An alternating current voltage is applied to the excitation winding, while the output is taken from the sensing winding.

The rotor is made up of a thin aluminium cylinder which is called a drag cup. This light inertia rotor is highly conducting and acts as short circuited secondary winding. A low reluctance path is provided by a ferromagnetic core.

The rotation of the rotor causes an induced voltage in the sensing winding and this voltage is proportional to the instantaneous value of speed if the excitation frequency is very large as compared with speed.

Advantages

(i) The drag cup type of a.c. tachogenerator described above is in fact a two phase squirrel cage induction motor. One of the windings is excited by carrier and the other winding develops an output voltage proportional to the speed. With the rotor stationary, the output voltage is zero. The rotation of rotor in one direction produces an output voltage at the terminals of the sensing winding. The frequency of the a.c. output voltage is the same as that of the excitation frequency with its amplitude proportional to the speed. The output voltage is in phase with the input excitation voltage. Reversal of the rotation produces an output voltage which is proportional to the speed but is 180° out of phase with the input voltage. This can be detected with a phase sensitive demodulator. Thus the arrangement affords a discrimination in the direction of the applied speed.

(ii) A linear relationship between the output voltage and speed is obtained if the carrier frequency is 5 to 10 times larger than the frequency of the speed signal. For this purpose the excitation winding is supplied with a frequency of 400 Hz.

(iii) The drag cup type tachometers are rugged and are in-expensive. Also, they require little maintenance.

(iv) In some situations these tachometers are very useful since they give a ripple free output.

Disadvantages

(i) The output voltage is proportional to the product of speed and input voltage. Thus, in order that the calibration of the tachometer holds good, the input voltage should be maintained absolutely constant.

(ii) These tachometers are hard to calibrate.

(iii) At high speed there exists a non-linear relationship between output voltage and the input speed. Hence corrections should be applied or otherwise higher carrier frequencies should be used. It is no doubt possible to excite the tachometer excitation winding with frequencies higher than 400 Hz if necessary, but some performance characteristics will change their value in the process.

29'30. Digital Methods

The electromechanical methods for measurement of angular velocity are satisfactory up to about a speed of 10,000 rpm. Higher speed measurements are possible with digital pickups which work in conjunction with digital frequency meters.

The biggest advantage of digital methods is that no direct physical contact is required with the shaft whose speed is to be measured. Therefore, no load is imposed upon the shaft by measuring device.

The digital pickups are of two types : (i) photo-electric type, and (ii) inductive type.

29'30'1. Photoelectric Tachometer. This method of measuring speed of rotation consists of mounting an opaque disc on the rotating shaft as is shown in Fig. 29'42.

The disc has a number of equidistant holes on its periphery. At one side of the disc a light source is fixed and at the other side of the disc, and on line with the light source, a light sensor such as a photo tube or some photosensitive semi-conducting device is placed. When the opaque portion of the disc is between the light source and the light sensor, the latter is unilluminated and produces no output. But when a hole appears between the two, the light falling upon the sensor produces an output pulse.

The frequency at which these pulses are produced depends upon the number of holes in the disc and its speed of rotation. Since the number of holes is fixed, the pulse rate is a function of speed of rotation. The pulse rate can be measured by an electronic counter which can be directly calibrated in terms of speed in rpm.

Advantages. This system has two distinct advantages :

(i) The output format is digital and this means that if the tachometer is a part of a digital instrumentation system, no analog to digital conversion is necessary.

(ii) The pulse amplitudes are constant. This simplifies the electronic circuitry.

Disadvantages

(i) A disadvantage is that the light source must be replaced from time to time. A typical life time for light source is 50,000 hours.

(ii) The accuracy of this method depends principally on the error represented by one pulse. The digital meters measure frequency by counting the number of input pulses which occur in short period of time called **gating period**. If this period is too small serious errors may be caused. The gating period should therefore, be chosen to give a sufficiently large count. In general, all the digits on the digital display should be utilized. The factors which the user can control to minimize the errors are :

(i) gating period, and (ii) number of pulses generated per revolution.

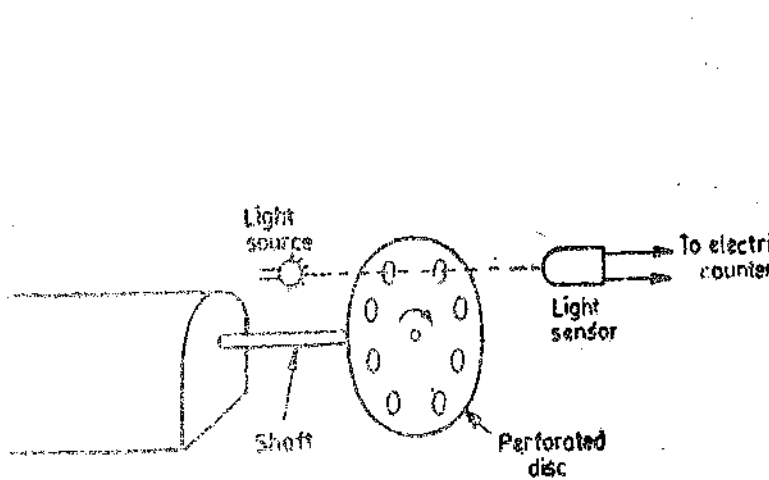

Fig. 29'42. Photoelectric tachometer.

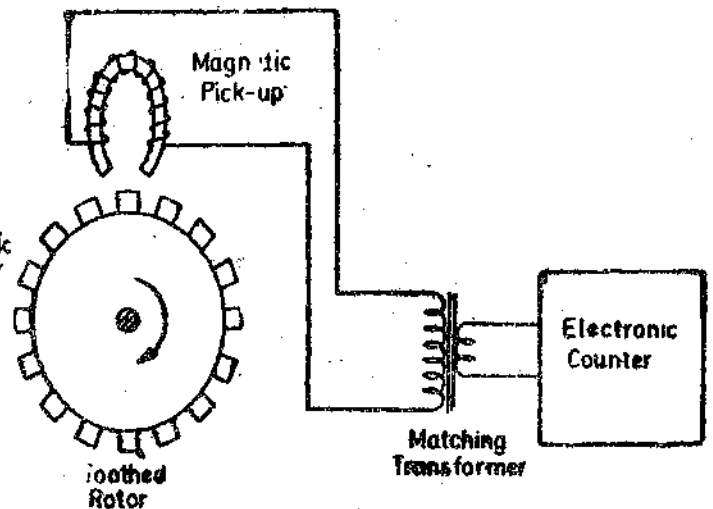

Fig. 29'43. Toothed rotor tachometer generator.

29'30'2. Toothed rotor variable reluctance tachometer. This tachometer generator consists of a metallic toothed rotor mounted on the shaft whose speed is to be measured. This is shown in Fig. 29'43. A magnetic pickup is placed near the toothed rotor.

The magnetic pick up consists of a housing containing a small permanent magnet with a coil wound round it. When the rotor rotates, the reluctance of the air gap between pickup and the toothed rotor changes giving rise to an induced e.m.f. in the pickup coil. This output is in the form of pulses, with a variety of waveshapes.

The frequency of the pulses of induced voltage will depend upon the number of teeth of the rotor and its speed of rotation. Since the number of teeth is known, the speed of rotation can be determined by measuring the frequency of pulses with an electronic counter. Suppose the rotor has T teeth, the speed of rotation is n rps and number of pulses per second is P .

$$\therefore \text{Number of pulses per revolution} = T$$

$$\text{Hence speed } n = \frac{\text{pulses per second}}{\text{number of teeth}} = \frac{P}{T} \text{ rps} = \frac{P}{T} \times 60 \text{ rpm} \quad \dots(29'23)$$

A typical rotor has 60 teeth. Thus if the counter counts the pulses in one second, the counter will directly display the speed in rpm.

We have mentioned above that the pulses have a variety of waveshapes. This is immaterial, as this tachometer is always connected to an electronic counter, whose requirement is merely that the amplitude be great enough to trigger a count.

Variable reluctance tachometer probably is the most common type of tachometer in use today.

Advantages. The advantages of this tachometer are :

- (i) It is simple and rugged in construction. (ii) It is maintenance free.
- (iii) It is easy to calibrate. This has been illustrated earlier, if the rotor has 60 teeth and the pulses are counted by counter in one second, the count displayed by the counter gives the speed directly in r.p.m.
- (iv) The information from this device can be easily transmitted.

Example 29'18. A variable reluctance type tachometer has 60 rotor teeth. The counter records 3600 counts per second. Determine the speed in rpm.

Solution.

$$\text{Speed} = \frac{\text{pulses per second}}{\text{number of teeth}} = \frac{3600}{60} \text{ rps} = 3600 \text{ rpm.}$$

Example 29'19. An inductive pickoff operating from a 120 tooth wheel is used with a digital frequency meter to measure the speed of rotation of the shaft on which the wheel is mounted. The gating period is set to $10^4 \mu\text{s}$, and a reading of 0030 is obtained on the four digit display. What shaft speed does this represent in r.p.s. ? If the available gating periods are $10^2, 10^3, 10^4, 10^5, 10^6, 10^7 \mu\text{s}$ respectively, what would be the optimum setting of gating period for making this measurement ?

Solution.

$$\therefore \text{Number of pulses per second} = \frac{\text{reading of digital meter}}{\text{gating period}} = \frac{0030}{10^4 \times 10^{-6}} = 3000$$

$$\therefore \text{Speed} = \frac{\text{number of pulses per second}}{\text{number of teeth}} = \frac{3000}{120} = 25 \text{ rps.}$$

The setting of the gating period for this measurement is $10^4 \mu\text{s}$ and this gives a reading of 0030 on a four digit display. It is seen that out of four digit places only two are utilized. For optimum setting of gating period, all the four digits places should be utilized. This requires that the gating time be increased by a factor 10^2 .

$$\therefore \text{Optimum gating time setting} = 10^4 \times 10^2 = 10^6 \mu\text{s.}$$

29 31. Stroboscope and Stroboscopic Methods

The stroboscope is a simple, portable manually operated device which may be used for measurement of periodic or rotary motions. Basically, the instrument is a source of variable frequency flashing brilliant light, the flashing frequency being set by the operator. The circuit used is based upon variable frequency oscillator which controls the flashing frequency. The speed is measured by adjusting the frequency so that the moving objects are visible only at specific intervals of time.

The method of use of the stroboscope depends upon imperfect dynamic response of the human eye. If a strong light is caused to flash on a moving object which, at the time each flash occurs, occupies a given position, the object will appear to be stationary. Therefore the method is useful for only those types of motions which occur regularly after a fixed interval of time, such as oscillation or rotation.

The stroboscope consists of a source of flashing light whose frequency can be varied and controlled. This source is called a **strobotron**.

29'31'1. Strobotron. It is hot cathode gaseous discharge tube as shown in Fig. 29'44. It has a cathode, an anode and two grids, one is called the inner grid and other as the outer grid.

If the potential of the outer grid is increased or that of inner grid is decreased beyond a certain limit, the conduction starts. Once the conduction starts, it can be stopped only by removing the anode potential.

The flashing of light is started by a signal from an oscillator or a multivibrator. When the tube is ionized and starts giving out flashes the capacitor C is discharged and a heavy current drawn by it reduces the anode potential due to large voltage drop in resistance R_1 . The ionization stops and so does the flashing of light. In the mean time the capacitor is recharged and waits for the next pulse to start the flashing again. The tube has a maximum flashing rate of 300 per second with effective discharge time of 10 to 100 μ s. The discharge current may be as high as 300 A.

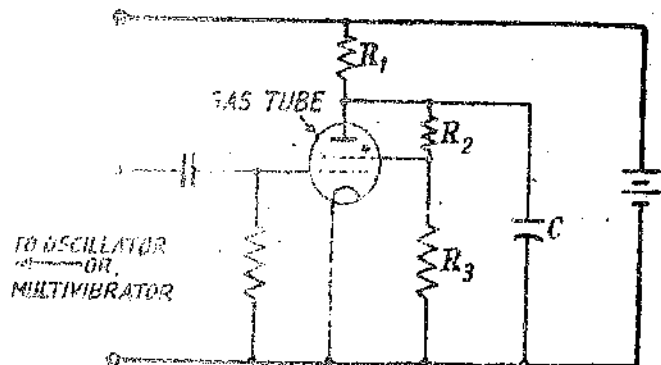

Fig. 29'44. Strobotron.

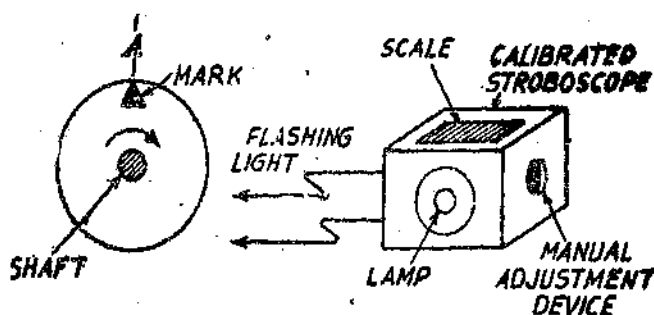

Fig. 29'45. Shaft speed measurement using stroboscope.

29'31'2. Shaft Speed Measurements. A distinctive mark is made on the shaft or on a disc attached to the shaft as shown in Fig. 29'45. A stroboscope is made to flash light directly on the mark. The flashing frequency is adjusted until the mark appears stationary. Under these conditions, the speed is equal to the flashing frequency provided that the approximate speed of the shaft is known in advance and the flashing frequency is not allowed to depart too much away from this value.

The scale of the stroboscope is calibrated in terms of speed which can be directly read off.

If the two conditions outlined above are not met or if there are several identical marks on the shaft like spokes of a wheel or jaws of a chuck, serious errors in the measurement may arise.

Consider first the case where there is only one mark as shown in Fig. 29'45. If the mark is at A every time a flash occurs, a stationary image appears. This is the case when $n=f$ where n =speed of shaft, rps and f =flashing frequency, Hz.

However, if $n=2f, 3f, 4f, \dots$ i.e., and if speed of shaft is any whole multiple of flashing frequency the mark would appear as stationary. Therefore, the mere fact that a stationary image is obtained does not guarantee the shaft speed with certainty.

It should be noted that this problem does not arise if $n < f$. Under these circumstances if n is a submultiple of f , Multiple images are obtained as shown in Figs. 29'46 (a) and (b).

The reason for formation of these multiple images may be visualized considering the case where $n=f/2$ as shown in Fig. 29'46 (a). Suppose a flash occurs when the mark is at A . With $n=f/2$, the next flash will occur after half a revolution i.e., when the mark is at B , and the next when the mark is at A and so on. Thus although the mark will be repeated at A when the flashes occur, it will also repeatedly be at B at the time of alternate flashes. Thus for $n=f/2$, two stationary marks will be seen.

Fig. 29'46 (b) shows the case where $n=f/3$, wherein a stationary mark is seen at three different places A, B and C . Thus the argument can be extended for cases $n=f/3, f/4, f/5 \dots$ etc. where 3, 4, 5 ..etc. stationary marks are seen for one mark on shaft.

Let us now consider the case, where there are multiple marks on the shaft. Fig. 29'47 shows a shaft with three identical, equispaced marks on the shaft. It is evident by considering the position of the marks as successive flashes occur, it can be seen that not only will the stationary pattern be obtained when $n=f, 2f, 3f$, etc. but also for certain values of n which are smaller than f , namely $n=f/3, 2f/3, 4f/3, 5f/3$, etc. This leads to the conclusion that there is a great possibility of error when using stroboscopic methods.

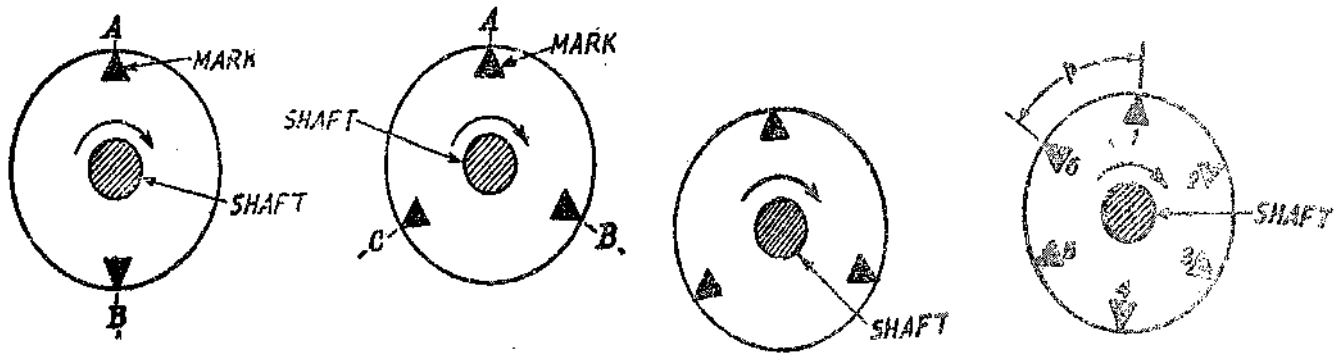

(a) $n = f/2$
Fig. 29'46. Formation of multiple images.

(b) $n = f/3$
Fig. 29'47. Stroboscope patterns with (multiple) three identical marks.

Fig. 29'48. Pattern having six marks.

From the above discussion, it is clear that in order to avoid gross mistakes in measurements :

(i) it is safest to work with a single mark and to find the highest flashing frequency at which a true image is seen, and

(ii) as a check that the correct value of speed, n has been found, the frequency may be doubled which should produce a double image. A method for finding speed of a multiple marked shaft is given below :

Fig. 29'48 shows a disc having 6 marks. This disc is attached to the shaft of the rotating machine and is illuminated by a series of successive flashes by a stroboscope. If the speed is such that each mark of star moves forward a distance of one point pitch (p) during the interval between successive flashes the pattern appears to be stationary. This speed is called primary speed. The pattern will also appear to be stationary if the speed or rotation is exactly twice, three times or any multiple of this speed.

When the disc appears to be stationary, the speed of rotating machine is given by

$$n = f/m \quad \dots(29'24)$$

where f = number of flashes per second, and m = number of point marks.

The stroboscopic dial may be directly calibrated to read the speed.

The disc appears stationary for all speeds which are a multiple of primary speed. Therefore, to avoid confusion an approximate value of actual speed should either be known or measured by other means.

The value of the exact speed may be found as under : Single line image is obtained by adjusting the stroboscope at its highest flashing frequency. The flashing rate is gradually reduced and the flashing frequencies are noted for all single line images. If single line images are obtained at m different flashing rates $f_1, f_2 \dots f_m$, the shaft speed is given by :

$$n = \frac{f_m f_1 (m-1)}{(f_m - f_1)} \quad \dots(29'25)$$

where f_m = highest flashing frequency, f_1 = lowest flashing frequency, m = number of flashing frequencies.

(These flashing frequencies refer to the frequencies at which single line images are obtained).

If the shaft (and alongside the disc) rotates at a speed slightly higher than the primary speed, the pattern appears to rotate slowly forward. On the other hand, if the speed is slightly less than the primary speed and the pattern apparently moves in the reverse direction to that of the direction of rotation of shaft. This is very useful for measurement of slip speed in induction motor.

29'31'3. Advantages and Disadvantages of Stroboscopic Methods :

- Advantages.** (i) This method imposes no load on the shaft.
(ii) It requires no special attachments with the shaft.

(iii) This method is particularly useful where it is inconvenient or impossible to make contact with the shaft.

(iv) It is very convenient to use a stroboscope for spot checks on machinery speeds and for laboratory work.

Disadvantages. (i) The circuit of the variable frequency oscillator cannot be stabilized to give a fixed frequency. Therefore, this method is less accurate than the methods utilizing digital meters.

(ii) The stroboscope cannot be used in surroundings where the ambient light is above a certain level. The stroboscope requires subdued lighting conditions for efficient operation.

Commercial models of stroboscopes are usually available in the speed range of 600 to 20,000 rpm.

Example 29'20. The speed of a shaft rotating at 2880 rpm is measured using a stroboscope. The stroboscope dial is slowly turned from setting of 4320 rpm to 1400 rpm corresponding to flash rate of 96 to 24 per second. (a) Indicate the speed settings which give single, double, and triple steady images. (b) What is the observation when the flashing rate is 50 per second?

Solution. Speed of shaft $n = 2880/60 = 48$ rps.

(.) If the flashing frequency is 48 per second the shaft completes one revolution during the interval between successive flashes and therefore we get a stationary image. If the flashing frequency is 24 per second, the shaft completes two revolutions during the interval between successive flashes, and hence again we get a stationary single image.

Therefore, for getting one stationary image the flashing rates should be either 24 or 48 per second. The other flashing frequencies which give stationary single line images lie outside the range of the instrument.

Double images are obtained if the shaft turns through $\frac{1}{2}$, $1\frac{1}{2}$ revolutions during successive flashes.

\therefore Flashing frequencies for double images are $48 \times 2 = 96$ or $48 \times (2/3) = 32$, i.e. 32 and 96 flashes per second.

Similarly for triple images, the flashing frequencies are :

$$48 \times 3 = 144 \text{ (not within range), } 48 \times (3/2) = 72, 48 \times (3/4) = 36, \\ \text{and } 48 \times (3/5) = 28.8 \text{ flashes/second}$$

(b) Rotation of shaft in $1/50$ s = $(1/50) \times 48 = 48/50$ revolution.

\therefore The image falls by $(1 - 48/50) = 2/50$ revolution within a time of $1/50$ s or by 2 rps.

Example 29'21. A stroboscope is directed at a rotating disc having five equispaced radial lines on it. The highest flashing frequency at which a true pattern is observed is 2000 flashes/minute. Give two other flashing frequencies which would produce (a) a 5 line pattern and (b) a 10 line pattern.

Solution. (a) The highest flashing frequency to give a 5 line pattern is 2000 per minute.

The other flashing frequencies which give a 5 line pattern are a submultiple of the highest frequency. These are :

$$2000/2 = 1000, 2000/3 = 666.7, 2000/4 = 500, 2000/5 = 400 \text{ or } 1000, 666.7, 500, 400 \text{ flashes/minute.}$$

(b) The flashing frequencies which give a 10 line pattern are twice in magnitude of those which give 5 line patterns. These are :

$$2000 \times 2 = 4000, 666.7 \times 2 = 1333, 400 \times 2 = 800 \text{ or } 4000, 1333, 800 \text{ flashes/minute.}$$

(Flashing frequencies of 2000 and 1000/minute are not included in the above list since they give 5 line patterns).

Example 29'22. While measuring speed of a steam turbine with stroboscope single line images were observed for stroboscope setting of 3000, 4000 and 5250 rpm determine the speed of the turbine.

Solution. The speed is given by Eqn. 29.25 : $n = \frac{f_m f_1 (m-1)}{(f_m - f_1)}$

Now $f_m = 5250$ rpm $f_1 = 3000$ rpm and $m = 3$

$$\therefore \text{Speed of steam turbine} = \frac{5250 \times 3000 (3-1)}{(5250-3000)} = 14000 \text{ rpm.}$$

Example 29.23. A disc mounted on the shaft of a machine has 12 pattern points. The number of flashes projected on the disc by a stroboscope is 6000 in a minute. (a) Find the speed of the machine if the disc appears stationary and has single image of 12 points.

(b) If the disc appears to move forward in the direction of rotation at 10 rpm, find the speed of the disc.

Solution. From Eqn. 29.24, speed of machine when patterns appear stationary,

$$n = f/m = 6000/12 = 500 \text{ rpm.}$$

Now the patterns move in the direction of rotation at a speed of 10 rpm.

\therefore The speed of machine in this case is : $n = 500 + 10 = 510$ rpm.

MEASUREMENT OF VIBRATIONS

29.32. Necessity for Measurement of Vibrations

The need for making measurement of vibrations has arisen mainly because of the growth of environmental testing. Specifications, many a times, require that the equipment should withstand stated levels of vibrations. This can be done quantitatively only through vibration measurements. Vibration measurements are frequently carried out on rotating and reciprocating machinery for analysis, design and trouble-shooting purposes.

Much knowledge has been gained in the recent years and computer solutions of various vibration problems have been developed. However, many a times to make actual measurements of vibration characteristics by tests, during development, either on the machine itself or on its prototype due the fact that it is impossible to build a perfect mathematical model with all its intricacies and complexities.

Vibration monitoring is carried out on such important machines as power station turbines and generators to give an early warning of impending conditions which may develop and lead to complete failure and destruction of the equipment.

29.32.1. Nature of vibrations. Most vibrations are sinusoidal displacement of the vibrating member about its mean position. A vibration of this nature may be defined by its amplitude and frequency.

For a sinusoidal vibration, the displacement is given by : $x = A \sin \omega t$

where $A =$ amplitude, $\omega =$ angular frequency ; rad/s,

Velocity $v = \dot{x} = A\omega \cos \omega t$ and maximum velocity $v_0 = A\omega$.

Acceleration $a = \ddot{x} = -A\omega^2 \sin \omega t$ and maximum acceleration $a_0 = -A\omega^2$

A sinusoidal vibration can, therefore, be defined by giving its frequency, plus its amplitude or maximum velocity or maximum acceleration.

29.32.2. Quantities Involved in Vibration Measurements. The quantities required to be measured in a vibrating system are displacement, velocity and acceleration. The peak values of the quantities should be known. Frequencies are measured and modes of vibration at particular frequency values may be observed. Displacement velocity and acceleration are related to each other. If one of the three variables concerned (displacement, velocity or acceleration) is measured, it is possible to determine the other two by integration or differentiation using electronic devices.

Measurements of vibration may therefore, be made with a transducer sensitive to amplitude (displacement), velocity or acceleration. The output of this transducer, after necessary signal conditioning is fed to the display which indicates or records the original measured variable or another variable derived from it. Since the transducer output is pulsating the frequency may be measured by a digital frequency meter at a suitable stage of signal conditioning process.

29.33. Seismic Transducer

A schematic diagram of a seismic transducer is shown in Fig. 29.49. It is called a seismic accelerometer also. The mass is connected through a parallel spring and damper arrangement to a housing frame. The housing frame is connected to the source of vibrations whose characteristics are to be measured. The mass has the tendency to remain fixed in its spatial position so that the vibrational motion is registered as a relative displacement between mass and housing frame. This displacement is sensed and indicated by an appropriate transducer.

The seismic transducer may be used in two different modes :

- (i) Displacement mode, and (ii) Acceleration mode.

The mode to be selected depends upon the proper selection of mass, spring and damper combinations. In general, a large mass and a soft spring are suited for displacement mode measurements, while a relatively small mass and a stiff spring are used for acceleration mode measurements.

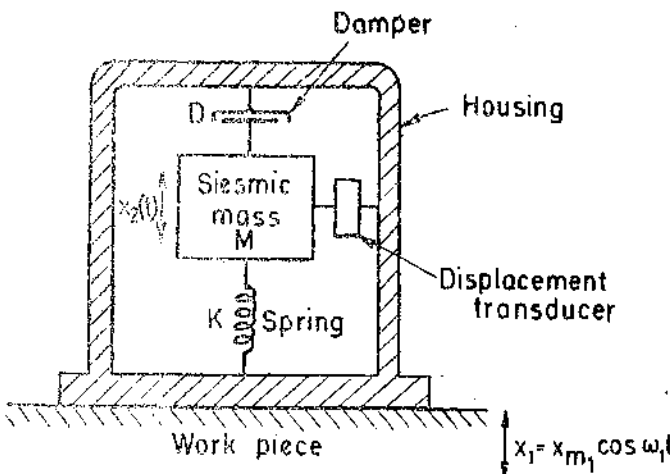

Fig. 29.49. Schematic diagram of a seismic transducer.

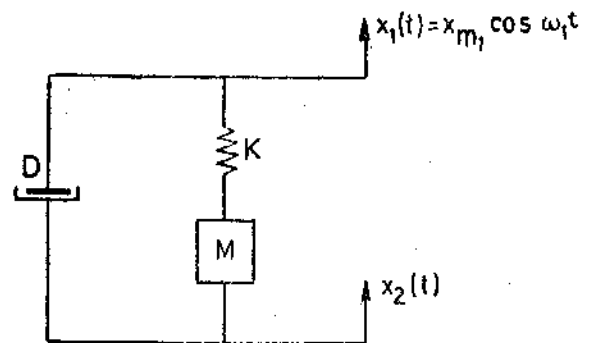

Fig. 29.50. Mechanical system for seismic transducer.

Fig. 29.50 shows the diagrammatic representation of the system to be analyzed.

The input is : $x_1 = x_{m1} \cos \omega_1 t$.

$$\text{Equation for motion can be written as } M\ddot{x}_2 + B\dot{x}_2 + Kx_2 = B\dot{x}_1 + Kx_1 \quad \dots(29.26)$$

We are interested in the relative displacement $x_0 = (x_1 - x_2)$ in terms of the above impressed motion. Therefore we can write the equation of motion as :

$$\ddot{x}_2 + (D/M)\dot{x}_2 + (K/M)x_2 = x_0 [(K/M) \cos \omega_1 t - (D/M) \omega_1 \sin \omega_1 t] \quad \dots(29.27)$$

$$\text{The steady state response is given by : } x = x_2 - x_1 = \frac{Mx_{m1} \omega_1^2 \cos(\omega_1 t - \phi)}{[(K - M\omega_1^2)^2 + D^2\omega_1^2]^{1/2}} \quad \dots(29.28)$$

The amplitude of relative displacement is :

$$x_0 = (x_2 - x_1)_0 = \frac{x_{m1} (\omega_1/\omega_n)^2}{\{[(1 - \omega_1/\omega_n)^2]^2 + \{2\zeta(\omega_1/\omega_n)^2\}^2\}^{1/2}} \quad \dots(29.29)$$

See frequency response of 2nd order systems on page 741.

$$= \frac{x_{m1} u^2}{[(1-u^2)^2 + (2\zeta u)^2]^{1/2}} \quad \dots(29'30)$$

Phase angle $\phi = \tan^{-1} \left(\frac{2\zeta u}{1-u^2} \right) \quad \dots(29'31)$

A plot of Eqn. 29'30 is given in Fig. 29'51. It is clear from the diagram that the output amplitude is almost equal to the input when $\zeta=0.7$ and $\omega_1/\omega_n > 2$.

For low values of damping ratio, ζ , the amplitude may become quite large. The output becomes essentially a linear function of input at high frequency ratios. Thus a seismic-vibration transducer should be used for measurement of displacement amplitude at frequencies substantially higher than its natural frequency. Now the natural frequency is $\omega_n = \sqrt{K/M}$. Therefore, this type of transducer (which requires small natural frequencies) should use weak springs (which have low value of K) and heavy mass, M .

The acceleration amplitude of the input vibration is : $a_0 = \ddot{x}_1 = \omega_1^2 x_{m1} \quad \dots(29'32)$

We may thus use the measured output of the instrument as an indication of acceleration and call the instrument as **accelerometer**. However, there are problems associated with this application. Fig. 29'52 shows the plot of $(x_2 - x_1)_0 \omega_n^2 / a_0$ versus ω_1/ω_n .

It is clear from Fig. 29'52 that the frequency response is unsatisfactory for frequency ratios greater than 0.4 as the curves tend to be non-linear. Thus if the device is to be used for acceleration measurements, the input frequency should be much lower than the natural frequency of the accelerometer. In order that the instrument be used for higher frequencies, it should be designed to have a high natural frequency. This requires a stiff spring (high value of K) and a small mass M .

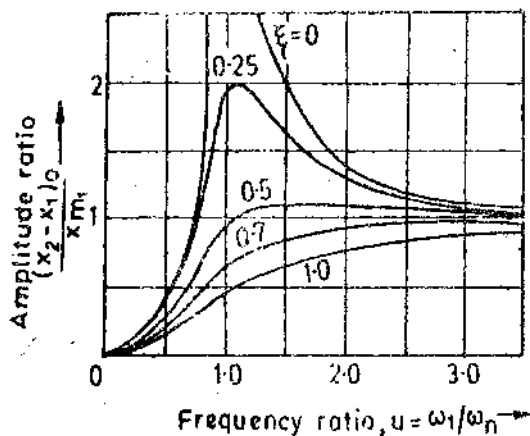

Fig. 29'51 Dynamic response of a Seismic transducer.

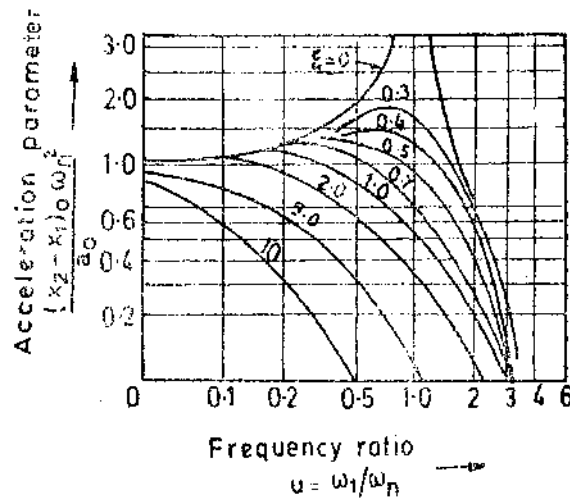

Fig. 29'52. Frequency response of a Seismic transducer.

The most important transducer for vibration, shock and general purpose absolute motion is the **accelerometer**. The instrument is commercially available in a wide variety of types and ranges in order to meet diverse application requirements.

29'34. Types of Accelerometers

The variety of accelerometers used results from different applications with varied requirements of range of natural frequency and damping. The specification sheet for an accelerometer gives the natural frequency, damping ratio, and a scale factor which relates output with the acceleration input.

29'34.1. Potentiometric Type Accelerometer

This is the most simple type of accelerometer. The seismic mass is attached to the wiper arm of resistance potentiometer. The relative motion of the mass with respect to the transducer frame is sensed either as a change in resistance or as a change in voltage output (if the potentiometer is used as potential divider). The damping may be provided by filling the housing of the accelerometer completely with a viscous fluid or it may be provided by a dashpot. Proper damping is necessary because it increases the range of frequencies over which the transducer may be used.

The major drawbacks of a seismic accelerometer using resistance potential divider are its limited resolution and a rather low natural frequency. This frequency is generally lower than 100 Hz and hence its application is limited to input frequencies lower than 50 Hz. Hence, this instrument is useful only for low frequency applications.

The instrument also gives errors on account of its sliding contacts.

29'34.2. LVDT Accelerometers

Fig. 29'53 shows a seismic accelerometer using a linear voltage differential transformer (LVDT). The core of the LVDT acts as the mass and two flexible reeds, attached at each end of the rods of the core, provide the necessary spring action. The reeds are attached to a housing which is subject to vibrations

The above arrangement is necessary in order that the core of the LVDT is maintained at its null position.

As the sensor moves up and down on account of vibrations, the LVDT secondaries give an a.c. output voltage, first of one phase and then, alternately of the opposite phase. The magnitude of this output signal depends upon the amplitude of the vibrations. The signal may then be rectified producing a voltage that alternately is positive and negative. By measuring peak to peak magnitude of this voltage, an indication of the amplitude of the vibrations may be obtained.

The advantages of accelerometers using LVDT are :

(i) The LVDT has a much smaller mass and thus has a higher natural frequency. Therefore, it can be used for measurement of vibrations of higher frequencies.

(ii) The LVDT offers a lower resistance to the motion than the potentiometer and is capable of a much better resolution.

(iii) It is a contactless device and is therefore free from problems which arise on account of moving contacts.

The LVDT accelerometers are used for steady state and low frequency vibration measurements.

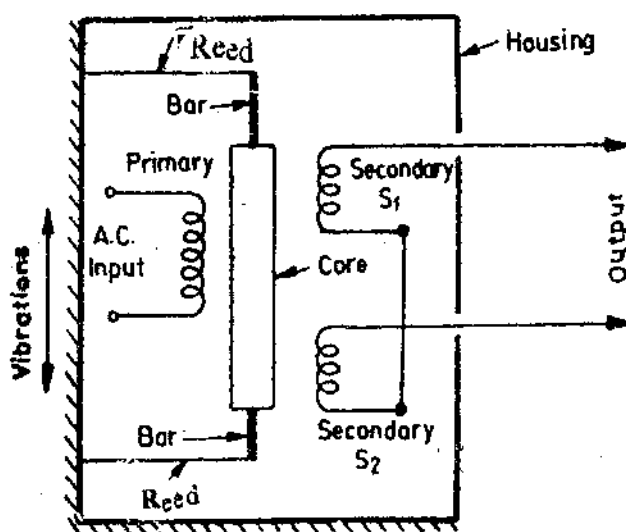

Fig. 29'53. Seismic accelerometer using LVDT.

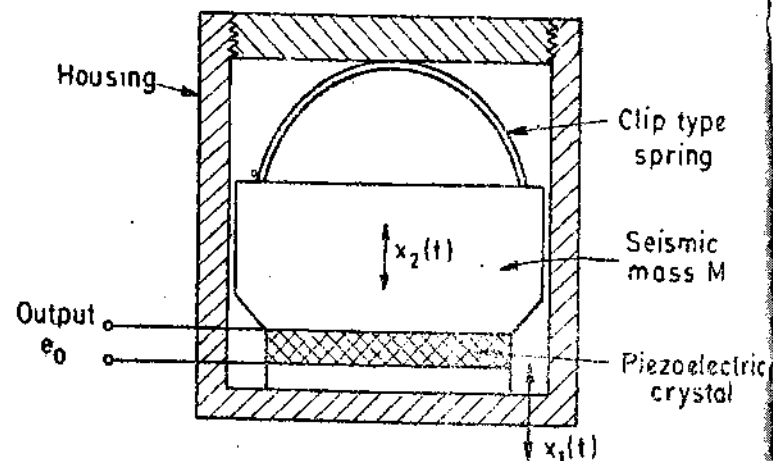

Fig. 29'54. Piezo-electric type accelerometer.

29'34'3. Piezo-electric Accelerometers

Piezoelectric transducers have been explained in details in Art 25'32 page 807.

When a force F is applied to a piezoelectric crystal it develops a charge $Q = dF$ coulomb (See Eqn. 25'63) where d = charge sensitivity of crystal ; C/N.

Through incorporation of a mass, m , in direct contact with the crystal, we have the essential components of an acceleration transducer. By applying a varying acceleration to the mass-crystal assembly, the crystal experiences a varying force. The force is given by $F = m \times a$ where a = acceleration.

This force generates a varying charge : $Q = dF = dMa$

Suppose the crystal has a capacitance, C , the no load output voltage is :

$$e_0 = \frac{Q}{C} = \frac{dF}{C} = d \frac{Ma}{C} \quad \dots(29'33)$$

Therefore the output voltage is a measure of the acceleration.

A typical piezo-electric accelerometer is shown in Fig. 29'54. The piezo-electric crystal is spring loaded with seismic mass in contact with the crystal. When subjected to an acceleration, the seismic mass stresses the crystal to a force $F = Ma$, resulting in a voltage generated across the crystal. This force, generates an output voltage which is proportional to the acceleration.

Some of the features of piezo-electric accelerometers are :

- (i) The instrument is quite small in size and has a small weight (Typically 0'025 kg).
- (ii) The natural frequency is very high. It may be as high as 100 kHz and therefore this accelerometer is useful for high frequency applications. They can be used for any vibration and shock applications.

The primary elements of importance in shock measurements are that the device should have a natural frequency which is greater than 1 kHz and a range typically greater than 500 g (i.e. $g = 9'81 \text{ m/s}^2$). The only accelerometer that can usually satisfy these requirements is the piezo-electric type.

(iii) The crystal is a source with a high output impedance and in order to avoid loading effect, a voltage monitoring source of a high input impedance should be used.

Electrical impedance matching between transducer and readout circuitry is usually a critical matter requiring a very careful design consideration.

(iv) These accelerometers are useful for high input frequencies and their response is poor at low frequencies. Therefore, they should not be used for applications where the input frequency is lower than 10 Hz.

Example 29'24. An accelerometer has a seismic mass of 0'05 kg and a spring constant of $3 \times 10^3 \text{ N/m}$. Maximum mass displacement is $\pm 0'02 \text{ m}$ (before the mass hits the stop). Calculate (a) maximum measurable acceleration and (b) natural frequency.

Solution : (a) Natural frequency $\omega_n = \sqrt{K/M} = \sqrt{3 \times 10^3 / 0'05} = 245 \text{ rad/s}$.

Maximum acceleration $a_0 = \omega^2 A = (245)^2 \times (0'02) = 1200 \text{ m/s}^2$.

(b) Natural frequency $f = 245 / 2\pi = 39 \text{ Hz}$.

Example 29.25. An accelerometer has a damping ratio of 0.7. Calculate the value of frequency ratio so that ratio of steady relative displacement to amplitude of input displacement is 0.99 (i.e. the error is 1.0%).

Solution. From Eqn. 29.30, we have $0.99 = \frac{u^2}{\sqrt{(1-u^2)^2 + (2\zeta u)^2}} = \frac{u^2}{\sqrt{(1-u^2)^2 + (2 \times 0.7u)^2}}$

$\therefore u = \text{normalized frequency} = \omega_1/\omega_n = 2.45.$

Example 29.26. A Seismic instrument has a natural frequency of 4 Hz and a damping ratio of 0.66. If the system is excited by a frequency 6 Hz, determine the error due to the proximity of excited frequency with natural frequency of the instrument.

Solution. The ratio of output displacement to input displacement is given by :

$$\frac{x_0}{x_m} = \frac{u^2}{\sqrt{(1-u^2)^2 + (2\zeta u)^2}} \quad (\text{See Eqn. 29.30})$$

Now normalized frequency $u = 6/4 = 1.5.$

$$\therefore \frac{x_0}{x_{m1}} = \frac{(1.5)^2}{[(1-1.5^2)^2 + (2 \times 0.66 \times 1.5)^2]^{1/2}} = 0.961$$

$$\therefore \text{Error} = (0.961 - 1) \times 100 = -3.9\%.$$

Example 29.27. An LVDT is used in an accelerometer to measure seismic mass displacements. The LVDT and signal conditioning outputs are 0.31 mV/mm with a ± 20 mm core displacement. The spring constant is 240 N/m and the core mass is 0.05 kg. Find (a) relation between acceleration in m/s^2 and the output voltage, (b) maximum acceleration measurable, and (c) natural frequency.

Solution. (a) The amplitude of displacement is proportional to the amplitude of vibration.

$$\therefore \text{Sensitivity of accelerometer} = \frac{\text{m/s}^2}{\text{mm}} \times \frac{\text{mm}}{\text{mV}} = \frac{96}{20} \times \frac{1}{0.31} = 15.5 \text{ ms}^{-2}/\text{mV}$$

(b) & (c) Natural frequency $\omega_n \sqrt{K/M} = \sqrt{240/0.05} = 69.3 \text{ rad/s.}$

Maximum measurable acceleration $= \omega^2 A = (69.3)^2 \times 20 \times 10^{-3} = 96 \text{ m/s}^2.$

Example 29.28. An accelerometer gives an output of 14 mV per g. Design signal conditioning that provides :

(a) a velocity signal scaled at 0.25 V/ms^{-1} and (b) determine the gain of the system and feedback resistance ratio.

Solution. Sensitivity $= \frac{14 \text{ mV}}{9.81 \text{ ms}^{-2}} = 1.43 \frac{\text{mV}}{\text{ms}^{-2}}$

This is an acceleration signal to be converted to a velocity signal, hence an integrator is used.

The circuit is shown in Fig. 29.55.

$$\text{Output of the integrator} = -\frac{1}{RC} \int e_i dt$$

Take $RC = 1 \text{ s.}$

$$\therefore \text{Output of integrator is : } \frac{1.43 \text{ mV}}{\text{ms}^{-2}} \times \frac{1}{1 \text{ s}} = -1.43 \text{ mV/ms}^{-1}$$

$$\text{Required gain} = \frac{0.25 \text{ V/ms}^{-1}}{1.43 \times 10^{-3} \text{ V/ms}^{-1}} = 174.8.$$

This can be obtained by using an inverter with $R_2 = 174.8 \text{ k}\Omega$ and $R_1 = 1 \text{ k}\Omega.$